

# OPERATOR'S MANUAL

# LM2305A-X-B

INCLUDING: SPECIFICATIONS, SERVICE KITS, GENERAL INFORMATION, PARTS, TROUBLESHOOTING  
INCLUDE MANUAL: S-632 GENERAL INFORMATION (PN 97999-624).

RELEASED: 12-27-04  
REVISED: 9-23-11  
(REV. 03)

**3" AIR MOTOR**  
**5:1 RATIO**  
**0 - 750 P.S.I. RANGE**



## LM2305A-XX-B TWO-BALL PUMP SERIES



**READ THIS MANUAL CAREFULLY BEFORE INSTALLING,  
OPERATING OR SERVICING THIS EQUIPMENT.**

It is the responsibility of the employer to place this information in the hands of the operator. Keep for future reference.

### SERVICE KITS

- Use only genuine ARO® replacement parts to assure compatible pressure rating and longest service life.
- **637226 Pump Rebuild Kit.** Includes the necessary soft parts for normal service of the entire pump.

### SPECIFICATIONS

<b>Model Series</b> (refer to option chart)	LM2305A-XX-B
<b>Type</b>	Air Operated, Two-Ball Double Acting Oil Pump
<b>Ratio</b>	5:1
<b>Air Motor Diameter</b>	3" (7.62 cm)
<b>Stroke</b>	3" (7.62 cm)
<b>Air Inlet (female)</b>	
LM2305A-X1-B	1/4 - 18 N.P.T.F. - 1
LM2305A-X2-B	Rp 1/4 (1/4 - 19 BSP Parallel)
<b>Material Inlet (female)</b>	
LM2305A-X1-B	1-1/2 - 11-1/2 N.P.T.F. - 1
LM2305A-X2-B	Rp 1-1/2 (1-1/2 - 11 BSP Parallel)
<b>Material Outlet (female)</b>	
LM2305A-X1-B	1/2 - 14 N.P.T.F. - 1
LM2305A-X2-B	Rp 1/2 (1/2 - 14 BSP Parallel)
<b>Pump Construction</b>	Carbon Steel
<b>Dimensional Data</b>	See chart
<b>Weight</b>	See chart

### PERFORMANCE

<b>Air Inlet Pressure Range</b>	0 - 150 p.s.i. (0 - 10.3 bar)
<b>Fluid Pressure Range</b>	0 - 750 p.s.i. (0 - 51.7 bar)
<b>Cycles / Minute Rec'd @ Working Flow</b>	170
<b>Displacement In<sup>3</sup> Per Cycle</b>	8.3
<b>Volume / Cycle</b>	4.60 oz. (135.97 ml)
<b>Cycles Per Gallon</b>	28
<b>Maximum Working Flow Rate</b>	6 g.p.m. (22.7 l.p.m.)
<b>Maximum Flow Rate</b>	9 g.p.m. (34.1 l.p.m.)
<b>Noise Level @ 100 p.s.i.</b>	85 db(A)*
<b>Accessories Available</b>	61113 Wall Mount Bracket 66073-1 Air Line Connection Kit

\* The pump sound pressure level has been updated to an Equivalent Continuous Sound Level (L<sub>Aeq</sub>) to meet the intent of ANSI S1. 13-1971, CAGI-PNEUROP S5.1 using four microphone locations.

### PUMP DATA

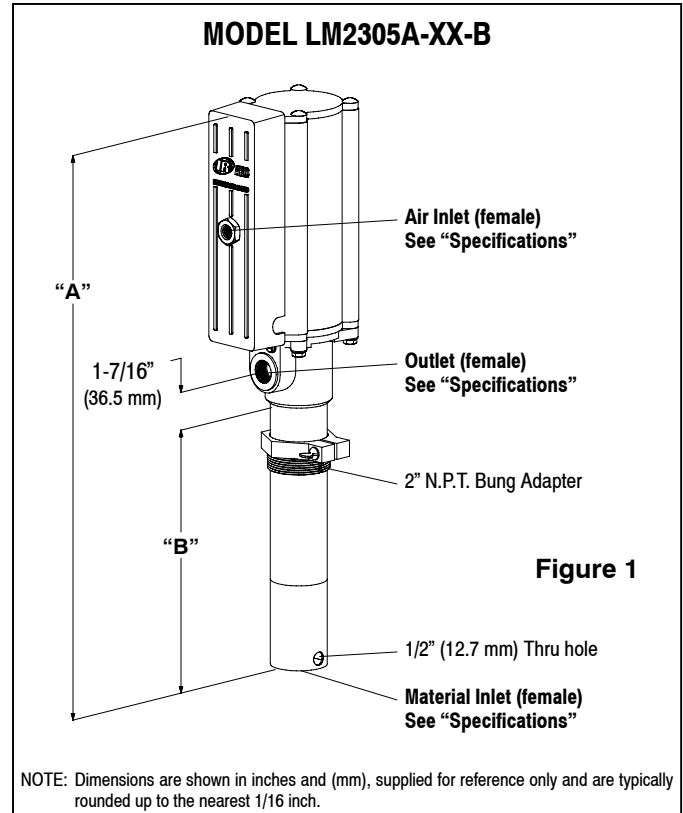

MODEL	"A" (mm)	"B" (mm)	WEIGHT (kg)
LM2305A-1X-B	21" (533.4)	9-3/4" (247.7)	15.75 (7.14)
LM2305A-3X-B	41-1/4" (1047.8)	30" (762)	24.3 (11.02)
LM2305A-4X-B	51" (1295.4)	39-3/4" (1009.7)	28.5 (12.93)
LM2305A-5X-B	58-5/8" (1489.1)	47-3/8" (1203.3)	31.7 (14.38)

### IMPORTANT

This is one of two documents which support the pump. Replace-  
ment copies of these forms are available upon request.

- LM2305A-X-B Model Operator's Manual
- S-632 General Information Lubrication Piston Pumps

## PARTS LIST / LM2305A-XX-B

Item	Description (size)	Qty	Part No.	[Mtl]
1	Carriage Bolt (1/4" - 20 x 9" long)	(4)	94333	[C]
2	Upper Cap	(1)	94390	[Z]
✓ 3	Gasket	(2)	94392	[B]
4	Sleeve	(2)	94316	[Br]
✓ 5	"O" Ring (1/16" x 11/16" o.d.)	(4)	Y325-15	[B]
✓ 6	"O" Ring (1/8" x 3/4" o.d.)	(4)	Y325-206	[B]
7	Spool	(2)	94310	[D]
✓ 8	"U" Cup (1/8" x 3/4" o.d.)	(2)	Y240-7	[B]
✓ 9	"O" Ring (0.106" x 0.587" o.d.)	(2)	15066-PM	[B]
10	Cylinder	(1)	94306	[A]
✓ 11	"O" Ring (1/16" x 7/16" o.d.)	(1)	Y325-11	[B]
12	Adapter - LM2305A-X <sub>1</sub> -B	(1)	94384	[C]
	- LM2305A-X <sub>2</sub> -B	(1)	94384-1	[C]
✓ 13	"O" Ring (1/16" x 3/4" o.d.)	(1)	Y325-16	[B]
15	Muffler Housing	(1)	94443	[A]
16	Foam Liner	(2)	94402	
17	Edge Trim	(2)	94378-1	[N]
18	Retaining Ring	(1)	94406	[C]
19	Washer	(1)	94515	[C]
✓ 20	"U" Cup (3/16" x 3" o.d.)	(2)	94518	[B]
21	Piston	(1)	94403	[D]
22	Lower Cap	(1)	94391	[Z]
✓ 23	"O" Ring (1/8" x 1-9/16" o.d.)	(1)	Y325-219	[B]
✓ 24	"O" Ring (3/32" x 2-1/8" o.d.)	(1)	Y325-135	[B]
25	Bushing	(1)	94387	[C]
✓ 26	Packing (3/8" x 1-13/16" o.d.)	(1)	94405	[U]
✓ 27	"O" Ring (3/32" x 1" o.d.)	(1)	Y325-117	[B]
28	Piston Rod (10.451" long)	(1)	94386	[C]

### GENERAL DESCRIPTION

Model LM2305A-X-B series two-ball, double acting pumps are intended to be used primarily for oil transfer and delivery systems. It is best to use this pump with low - medium viscosity fluids. It uses carbon steel and other materials which make it compatible with most petroleum based lubrication products. The two-ball design provides better priming of the lower foot valve. Double acting pumps will deliver material on both the up and down stroke.

NOTE: If this pump was purchased separately (not part of a system), consult your sales representative for compatible dispensing accessories which will best match the application. All accessories must be able to withstand the maximum pressure developed by the pump.

Item	Description (size)	Qty	Part No.	[Mtl]
29	Rod - LM2305A-1X-B (1" long)	(1)	Y23-191	[C]
	- LM2305A-3X-B (21-7/32" long)	(1)	94450-3	[C]
	- LM2305A-4X-B (30-31/32" long)	(1)	94450-4	[C]
	- LM2305A-5X-B (38-19/32" long)	(1)	94450-5	[C]
30	Cup Follower	(1)	94517	[C]
✓ 31	Piston Cup	(1)	94449	[U]
32	Washer	(1)	94516	[C]
33	Ball (1" o.d.)	(1)	Y16-232	[C]
34	Inner Check Seat	(1)	75681	[C]
35	Base - LM2305A-X <sub>1</sub> -B	(1)	96250	[C]
	- LM2305A-X <sub>2</sub> -B	(1)	96250-1	[C]
36	Nut (1/4" - 20)	(4)	93828	[SS]
37	Ground Screw (#10 - 32 x 1/4")	(1)	93005	[C]
✓ 38	Gasket	(1)	96032	[Co]
39	Tube - LM2305A-1X-B (7-1/2" long)	(1)	94393-1	[C]
	- LM2305A-3X-B (27-23/32" long)	(1)	94393-3	[C]
	- LM2305A-4X-B (37-15/32" long)	(1)	94393-4	[C]
	- LM2305A-5X-B (45-3/32" long)	(1)	94393-5	[C]
✓ 40	"O" Ring (1/8" x 1-7/8" o.d.)	(1)	Y325-223	[B]
41	Ball (1-1/4" o.d.)	(1)	Y16-240	[C]
42	Ball Stop Pin (3/16" dia. x 1-13/16")	(1)	83009	[C]
43	Foot Valve Seat - LM2305A-X <sub>1</sub> -B	(1)	94398	[C]
	- LM2305A-X <sub>2</sub> -B	(1)	94398-1	[C]
44	Bung Ass'y (includes items 45 and 46)	(1)	67145-4-B	[Z]
45	Thumb Screw (1/4" - 20 x 1-1/2")	(1)	Y197-158-C	[C]
46	Nut (1/4" - 20)	(1)	Y12-4-C	[C]
✓	Gadus S2 U1000 Grease Packet	(1)	94833	
✓	Parts in Repair Kit		637226	

### MATERIAL CODE

[A] = Aluminum	[Co] = Copper	[SS] = Stainless Steel
[B] = Nitrile	[D] = Acetal	[U] = Polyurethane
[Br] = Brass	[N] = Neoprene	[Z] = Zinc
[C] = Carbon Steel		

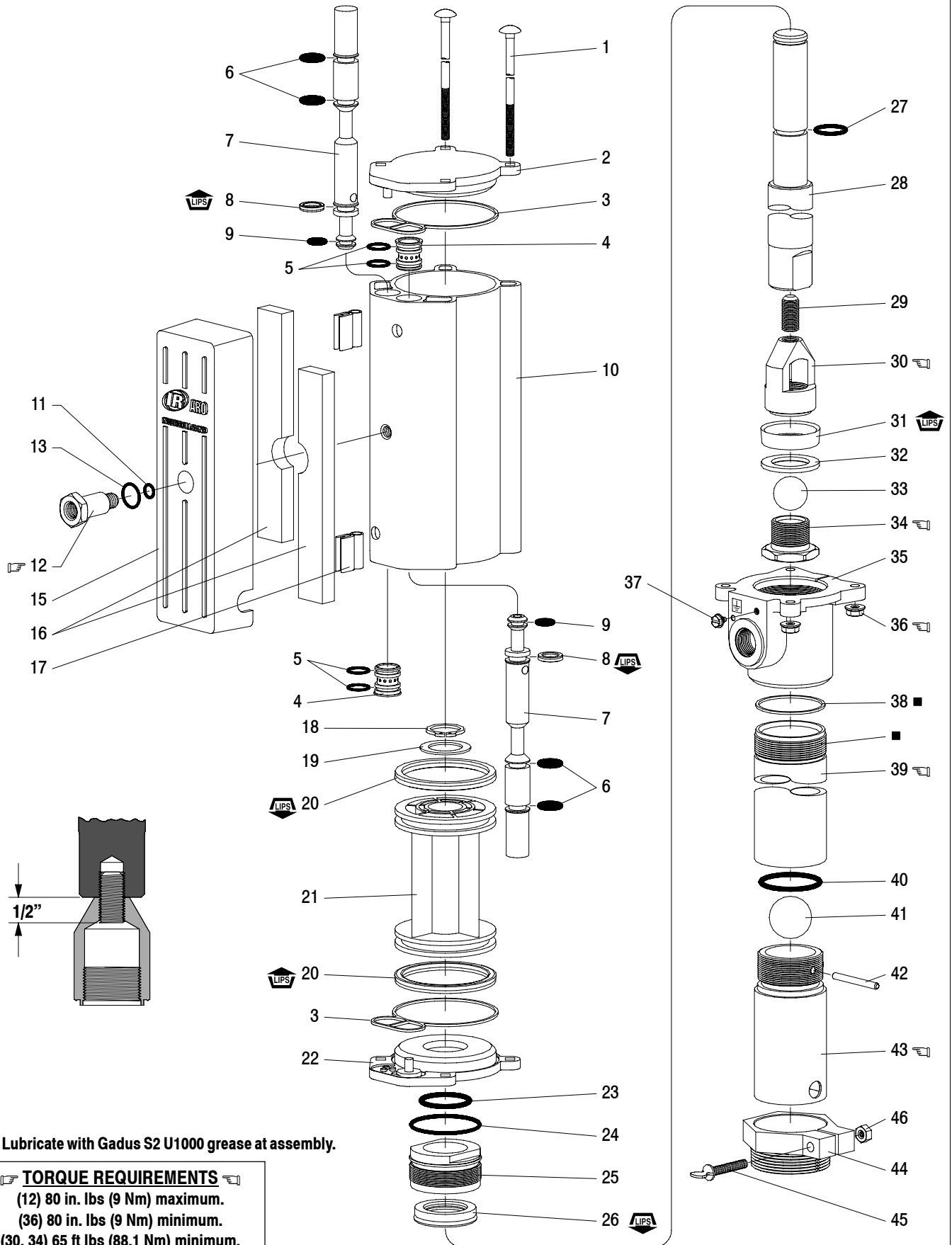

Figure 2

## OPERATING AND SAFETY PRECAUTIONS

**⚠ WARNING** READ THE GENERAL INFORMATION MANUAL INCLUDED FOR ADDITIONAL OPERATING AND SAFETY PRECAUTIONS AND OTHER IMPORTANT INFORMATION.

**⚠ WARNING** EXCESSIVE INLET PRESSURE. Can cause explosion resulting in severe injury or death. Do not exceed maximum operating pressure of 750 p.s.i. (51.7 bar) at 150 p.s.i. (10.3 bar) inlet air pressure. Do not run pump without using a regulator to limit air supply pressure to the pump.

**⚠ WARNING** EXCESSIVE MATERIAL PRESSURE. Can cause equipment failure resulting in severe injury or property damage. Do not exceed the maximum material pressure of any component in the system.

PUMP RATIO X INLET PRESSURE TO PUMP MOTOR	=	MAXIMUM PUMP FLUID PRESSURE
Pump ratio is an expression of the relationship between the pump motor area and the lower pump end area. EXAMPLE: When 150 p.s.i. (10.3 bar) inlet pressure is supplied to the motor of a 5:1 ratio pump it will develop a maximum of 750 p.s.i. (51.7 bar) fluid pressure (at no flow) - as the fluid control is opened, the flow rate will increase as the motor cycle rate increases to keep up with the demand.		

NOTICE: Thermal expansion can occur when the fluid in the material lines is exposed to elevated temperatures. Example: Material lines located in a non-insulated roof area can warm due to sunlight. Install a pressure relief valve in the pumping system.

Replacement warning label (pn 94520) is available upon request.

## PUMP DISASSEMBLY

**NOTE: All threads are right hand. Refer to figure 2 (page 3). Disconnect air supply and relieve all system pressure prior to servicing.** Carefully remove the parts, inspect for damage, nicks or excessive wear and determine if any parts will need replacement.

- Using a 7/8" wrench, unthread and remove (12) adapter and (11 and 13) "O" rings, releasing (15) muffler housing.
- Using a 7/16" wrench, remove (36) nuts.
- Remove four (1) bolts, (2) upper cap and (3) gasket.
- Remove (10) cylinder, containing (4) sleeves and (7) spools.
- Using (1) bolt, push (7) spools and (4) sleeves out "sleeve" end of (10) cylinder.
- Pull up on (21) piston and (22) lower cap, allowing access to (25) bushing.
- Using a 1-5/8" wrench, unthread (25) bushing and pull (28) piston rod and components from pump.
- Clamp on flats of (28) piston rod in a vise. Using an 11/16" wrench on flats of (30) cup follower, unthread and remove from (28) piston rod.
- Clamp on flats of (30) cup follower in a vise. Using a 1-1/2" wrench, unthread and remove (34) inner check seat, releasing (32) washer, (33) ball and (31) piston cup.
- Remove (25) bushing from (28) piston rod.
- Remove (24) "O" ring and (26) packing from (25) bushing.

## PUMP REASSEMBLY

**NOTE: Thoroughly clean and lubricate all seals. Replace all soft parts with new ones included in the repair kit.** Note: Refer to the illustration (figure 2, page 3) for "U" cup lip seal direction.

- Replace (27) "O" ring on (28) piston rod.
- Replace (20) "U" cups on (21) piston and assemble (21) piston onto (28) piston rod, securing with (19) washer and (18) retaining ring.
- Assemble (3) gasket to (22) lower cap and assemble (22) lower cap and (23) "O" ring onto (28) piston rod.
- Assemble (33) ball and (31) piston cup to (30) cup follower, securing with (32) washer and (34) inner check seat.
- Replace (26) packing in (25) bushing.
- Replace (24) "O" ring on (25) bushing and assemble (25) bushing onto (28) piston rod.
- Clamp on flats of (28) piston rod in a vise.
- Assemble (29) rod and (30) cup follower to (28) piston rod and tighten by using a 1-1/2" wrench on (34) inner check. NOTE: Torque (34) check seat to 65 ft lbs (88.1 Nm).
- Clamp (39) tube horizontally in a vise.
- Assemble (28) piston rod and components into (35) base.
- Using a 1-5/8" wrench, thread (25) bushing into (35) base until it "bottoms". NOTE: Be careful not to raise any burrs on flats of (25) bushing.
- Replace (5) "O" rings on (4) sleeves and assemble (4) sleeves into (10) cylinder. NOTE: Assemble each sleeve into the end of the cylinder nearest the exhaust hole.
- Replace (6 and 9) "O" rings and (8) "U" cups on (7) spools and assemble (7) spools into (10) cylinder from the opposite end as the (4) sleeve went in.
- Assemble (10) cylinder onto the pump, being careful when sliding over the lips of (20) "U" cups. NOTE: Be sure (3) gasket is seated properly.
- Replace (3) gasket on (2) upper cap and assemble (2) upper cap to (10) cylinder.
- Assemble (1) bolts to pump, securing with (36) nuts. NOTE: Torque (36) nuts evenly to 80 in. lbs (9 Nm).
- Replace (11 and 13) "O" rings on (12) adapter.
- Assemble (16) foam liners and (17) edge trims to (15) muffler housing.
- Assemble (15) muffler housing to (10) cylinder, securing with (12) adapter. NOTE: Torque (12) adapter to 80 in. lbs (9 Nm).

## TROUBLE SHOOTING

**If the pump will not cycle or will not deliver material.**

- Be certain to check for non-pump problems including kinked, restrictive or plugged inlet / outlet hose or dispensing device. Depressurize the pump system and clean out any obstructions in the inlet / outlet material lines.
- Check all seals, including track gaskets.
- Check direction of "U" cup lips.

## Free Manuals Download Website

<http://myh66.com>

<http://usermanuals.us>

<http://www.somanuals.com>

<http://www.4manuals.cc>

<http://www.manual-lib.com>

<http://www.404manual.com>

<http://www.luxmanual.com>

<http://aubethermostatmanual.com>

Golf course search by state

<http://golfingnear.com>

Email search by domain

<http://emailbydomain.com>

Auto manuals search

<http://auto.somanuals.com>

TV manuals search

<http://tv.somanuals.com>