

NON-CONTACT 3D DIGITIZER

VIVID 9i/VI-9i

Instruction Manual (HARDWARE)

NOTE

The VI-9i is model name for Europe and the VIVID 9i is model name for other countries.
Please note that the VIVID 9i model name is intended only for reference with this manual.



KONICA MINOLTA

Safety Symbols

The following symbols are used in this manual to prevent accidents which may occur as result of incorrect use of the instrument.



Denotes a sentence regarding safety warning or note.
Read the sentence carefully to ensure safe and correct use.



Denotes a prohibited operation.
The operation must never be performed.



Denotes an instruction.
The instruction must be strictly adhered to.



Denotes an instruction.
Disconnect the AC power cord from the AC outlet.



Denotes a prohibited operation.
The part must never be disassembled.



Denotes an instruction.
Connect the grounding terminal as instructed.



Denotes a sentence regarding safety precaution for laser.
Read the sentence carefully to ensure safe and correct use.

Notes on this Manual

- Copying or reproduction of all or any part of the contents of this manual without KONICA MINOLTA SENSING's permission is strictly prohibited.
- The contents of this manual are subject to change without prior notice.
- Every effort has been made in the preparation of this manual to ensure the accuracy of its contents. However, should you have any questions or find any errors, please contact a KONICA MINOLTA SENSING-authorized service facility.
- KONICA MINOLTA SENSING will not accept any responsibility for consequences arising from the use of the instrument.
- Company names and product names which appear in this manual are their trademarks or registered trademarks.
- Contents and display examples given in this manual are subject to change.

About This Manual and Related Documents















The VIVID 9i Non-Contact 3D Digitizer offers rapid, high-precision 3D scanning ideal for imaging of industrial products in a wide range of shapes and configurations. This manual describes the digitizer's features and operating procedures, and calls attention to relevant precautions.





Please also refer to documents listed below for related information.

Document	Content
Polygon Editing Tool Instruction Manual	Explains how to install and use the Polygon Editing software, and gives details about all of the software's features. The Polygon Editing Tool software can be used to control the operation of VIVID non-contact 3D digitizers, to convert scanned data into polygon data, to edit and process the scanned data, and to save the data into standard formats.
Polygon Editing Tool Basic Operations Guide	Explains the basic operations of the Polygon Editing Tool software, with reference to the VIVID 910 digitizer.
Photogrammetry System PSC-1 Instruction Manual	Explains the PSC-1 system, a high-precision alignment system based on photographic measurement technology. This system is for use in the VIVID 9i only.

Safety Precautions

When using this hardware, the following points must be strictly observed to ensure correct and safe use. After you have read this manual, keep it in a safe place so that it can be referred to easily whenever it is needed.

 WARNING Failure to adhere to the following points may result in death or serious injury.			
	Do not use the VIVID 9i in places where flammable or combustible gases (gasoline etc.) are present. Doing so may cause a fire.		Do not disassemble or modify the VIVID 9i. Doing so may cause a fire or electric shock.
	Always use the AC power cord supplied as a standard accessory with the VIVID 9i, and connect it to an AC outlet (100-240 V \sim , 50-60 Hz). Failure to do so may damage the VIVID 9i, causing a fire or electric shock.		Do not remove the cover as doing so may cause electric shocks.
	Do not bend, twist or pull the AC power cord excessively. In addition, do not place heavy items on the AC power cord, or damage or modify it in any way. Doing so may cause damage to the AC power cord, resulting in fire or electric shock.		Take special care not to allow liquid or metal objects to enter the VIVID 9i. Doing so may cause a fire or electric shock. Should liquid or metal objects enter the VIVID 9i, turn the power OFF immediately, disconnect the AC power cord from the AC outlet, and contact the nearest KONICA MINOLTA SENSING-authorized service facility.
	If the VIVID 9i will not be used for a long time, disconnect the AC power cord from the AC outlet. Accumulated dirt or water on the prongs of the AC power cord's plug may cause a fire. If there is any dirt or water on the prongs of the AC power cord's plug, remove it.		The VIVID 9i should not be operated if dirt or dust has entered through the vent holes. Doing so may result in a fire. For periodic inspection, contact the nearest KONICA MINOLTA SENSING-authorized service facility.
	When disconnecting the AC power cord's plug, always hold the plug and pull it to remove it. Never pull the AC power cord itself. Doing so may damage the AC power cord, causing a fire or electric shock. In addition, do not insert or disconnect the AC power cord's plug with wet hands. Doing so may cause electric shock.		Never stare into the laser emitting window. 
	The VIVID 9i should not be operated if it is damaged, or smoke or odd smells are detected. Doing so may result in a fire. In such situations, turn the power OFF immediately, disconnect the AC power cord from the AC outlet, and contact the nearest KONICA MINOLTA SENSING-authorized service facility.		Do not place a lens, mirror or optical element in the passage of the laser beam. Doing so may converge the laser beam, resulting in damage to your eyes, burns or fire. To prevent the above accidents, make sure that a wall or similar which can block the laser beam is located behind the object. 

 CAUTION Falling to adhere to the following points may result in injury or damage to the instrument or other property.			
	Be sure to connect the AC power cord's plug to an AC outlet that has a grounding terminal.		Do not place the instrument on an unstable or sloping surface. Doing so may result in its dropping or overturning, causing injury. Take care not to drop the instrument when carrying it.
	Make sure that the AC outlet is located near the VIVID 9i and that the AC power cord's plug can be easily connected and disconnected.		

Laser Caution and Identification Label

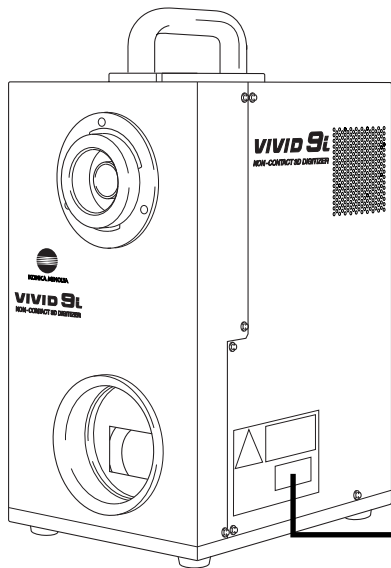

Laser Caution and Identification Label

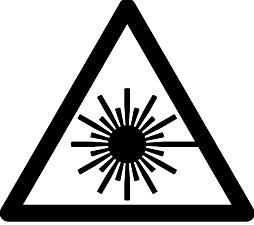

AVOID EXPOSURE
Laser radiation is emitted
from this aperture.

⚠ CAUTION

レーザー光
ビームをのぞきまなないこと
LASER RADIATION
DO NOT STARE INTO BEAM
LASER STRAHLUNG
NICHT IN DEN STRAHL SEHEN

MAX 30mW 690nm

クラス2 レーザ製品 CLASS 2 LASER PRODUCT
Complied with IEC Publication 60825-1:1993, Amendment-2:2001

CLASS 1 LASER PRODUCT

Complies with 21 CFR Chapter 1. Subchapter J.

KONICA MINOLTA SENSING, INC. 3-91, Daisennishimachi, Sakai, Osaka 590-8551, Japan
manufactured

Warning Label

⚠ 警告 ⚠ WARNING ⚠ WARNUNG

- 

● ご使用前には、必ず取扱説明書をよくお読みください。
Read and understand all instructions before using.
Vor Inbetriebnahme unbedingt zuerst alle Hinweise zur Bedienung und Handhabung sorgfältig studieren.

- 

● 本機を改造あるいは分解しないでください。火災、感電、または傷害の原因になります。
Risk of electric shock, fire or injury, not modify or disassemble this instrument.
Elektroschock, Feuergefahr und Verletzung Das Gerät nicht demontieren oder Veränderungen am Gerät vornehmen.

- 

● コンセントが近くにあり、電源プラグの抜き差しが容易にできること
The socket-outlet shall be installed near equipment and shall be easily accessible.
Die Netzsteckdose sollte leicht erreichbar und in der Nähe des Gerätes installiert sein.

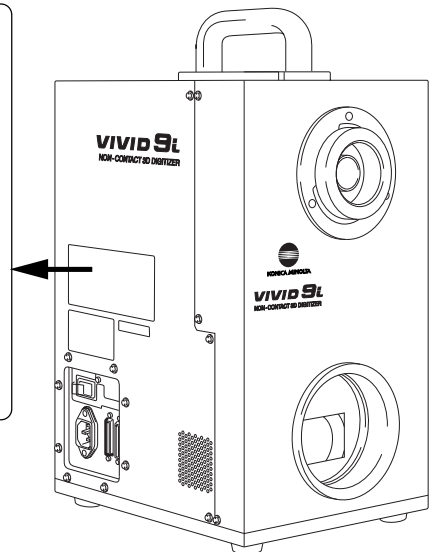

Notes On Use

- The VIVID 9i is designed for indoor use only, and should never be used outside.
- This digitizer has been calibrated at 20°C. We recommend that you use it in environments where ambient temperature is 20°C (68°F).
- Use an AC power source which is within $\pm 10\%$ of the rated voltage.
- The VIVID 9i should be used within a temperature range of 10 to 40°C at a relative humidity of 65% or less.
- Do not use the VIVID 9i in direct sunlight or near sources of heat such as stoves. Doing so will cause the temperature of the VIVID 9i to rise considerably higher than room temperature and may result in malfunctions. Use the VIVID 9i in a well ventilated area and make sure that the ventilation holes of the VIVID 9i are not blocked.
- Do not use the VIVID 9i in extremely dusty or humid areas. Doing so may result in malfunctions.
- Do not subject the VIVID 9i to strong vibration or shocks. Doing so may result in malfunctions.
- When using the VIVID 9i on upper floors of buildings or near high-traffic streets, the instrument and/or measurement subject may vibrate, adversely affecting measurement results.
- Do not allow the digitizer to fall on its side, as it may sustain damage if knocked over.
- Do not disconnect cords and cables with the POWER switch of the VIVID 9i set to ON "I". Doing so may result in malfunctions.
- The VIVID 9i has been tested and found to comply with the limits for a Class A digital device, pursuant to Part 15 of the FCC Rules. These limits are designed to provide reasonable protection against harmful interference when the equipment is operated in a commercial environment. This equipment generates, uses, and can radiate radio frequency energy and, if not installed and used in accordance with the instruction manual, may cause harmful interference to radio communications. Operation of this equipment in a residential area is likely to cause harmful interference in which case the user will be required to correct the interference at his own expense.
- The VIVID 9i is a class II instrument specified in IEC Publication 825. Use it according to the instructions given in this manual.
- Do not use the VIVID 9i at altitudes of higher than 2000 m.
- Before using this unit for the first time, and before reusing it following transport, check that the lens is securely in place. If the lens is loose, tighten it in accordance with the tightening instructions included in the lens replacement procedure.

Care On Storage

- The VIVID 9i should be stored in areas with temperatures of between 0 and +40°C. Do not store it in areas subject to high temperature or high humidity or where sudden changes in temperature or condensation are likely to occur. We recommend storing the VIVID 9i around room temperature ($20 \pm 3^\circ\text{C}$) with a desiccant (silica gel etc.).
- Do not leave the VIVID 9i inside a closed car or in the trunk of a car. Under direct sunlight, the increase in temperature can be extreme and may result in malfunctions.
- The VIVID 9i should not be stored in areas where there is an excessive amount of dust, cigarette smoke or chemical gas. Failure to adhere to this may result in performance degradation or break-down.
- When shipping the product, use the original packing materials in which the product was shipped. The materials will provide protection against vibrations and impact, and also provide some protection against sudden changes in temperature.
- Lenses that are not in use should be capped and kept in the lens case.
- Before storing this equipment, be sure to attach the receiving lens cap and the laser barrier.

Notes On Cleaning

- If the VIVID 9i needs cleaning, wipe with a soft dry cloth. Never use solvents such as thinner or benzene.
- If the lens or laser emitting window is soiled with sand or dust, blow off the dirt using a blower, and wipe them gently with a piece of cleaning paper dampened with cleaning agent.
- In cases of malfunction, do not disassemble the VIVID 9i or attempt to repair it yourself. Contact the nearest KONICA MINOLTA SENSING-authorized service facility.

Notes On Maintenance

To maintain the accuracy of the high-precision Galvano mirror, that plays the most important role in measurement accuracy, a drying agent is used inside the VIVID 9i. Normally, the dehumidification effect of the drying agent lasts more than one year. However, its life varies with the operating and storage environment.

To maintain the designed performance of the VIVID 9i, you are recommended to replace the drying agent once a year. Contact the nearest KONICA MINOLTA SENSING-authorized service facility.

Contents

Safety Precautions.....	1
Laser Caution and Identification Label.....	2
Warning Label.....	2
Notes On Use.....	3
Care On Storage.....	3
Notes On Cleaning.....	4
Notes On Maintenance.....	4

Chapter 1 Before Using the Instrument

Package Contents (Standard Accessories)	8
Optional Accessories	10
System Configuration	11
Names and Functions of Parts	12
Main Body.....	12
Operation Panel.....	13

Chapter 2 Preparation

Connecting the AC Power Cord	16
Connecting the VIVID 9i to a Computer	17
Setting the SCSI ID No.....	18
Setting the Terminator.....	19
Starting and Quitting	21
Starting the VIVID 9i.....	21
Quitting the VIVID 9i.....	23
Mounting to the Tripod	24

Chapter 3 Operation

Replacing the Lens and Field Calibration	28
Relationship between Measurement Distance and Object.....	28
Replacing Procedure.....	29
Field Calibration	32
Field Calibration System.....	32
Executing Field Calibration.....	34
Adjusting the White Balance	42
Displaying the Status Information	44
Adjusting the Laser Power and CCD Gain Manually	45
Setting the Scan Mode	46

Chapter 4 Appendix

Error Messages	48
Explanation of Measuring Principle	49
Measuring Principle.....	49
High-Speed Image Processing Circuit.....	50
Time center of gravity and Space center of gravity.....	50
Dimension Diagram	51
Specifications	52





Chapter 1

Before Using the Instrument

Package Contents (Standard Accessories)

Check that the following standard accessories are present.

VIVID 9i Main Body

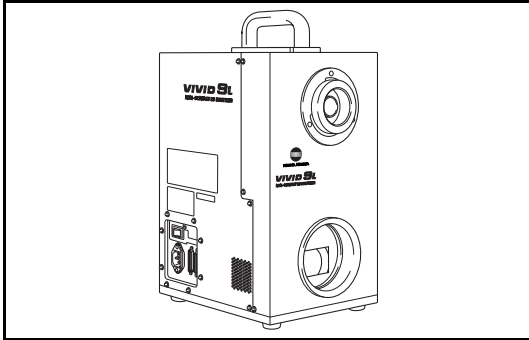

Polygon Editing Tool
(with USB protect key)

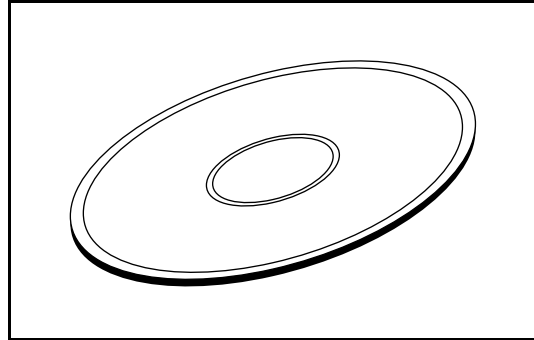

White Balance Cap VI-A10

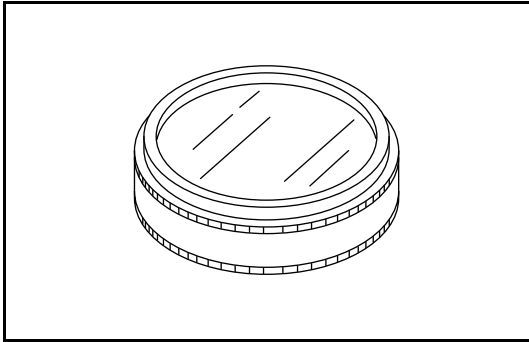

AC Power Cord

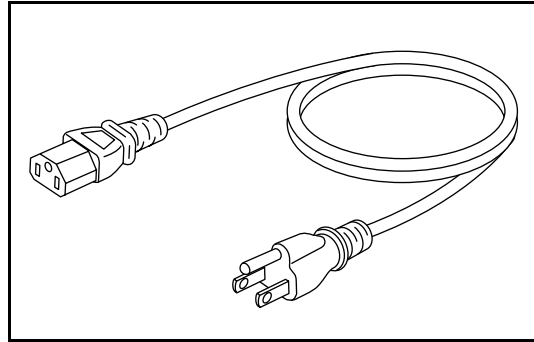

SCSI Cable VI-A20
(Half-pitch, D-sub, 50-pin male plug
– 50-pin male plug)

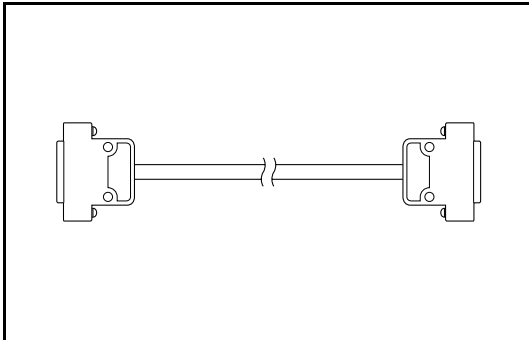

Laser Barrier

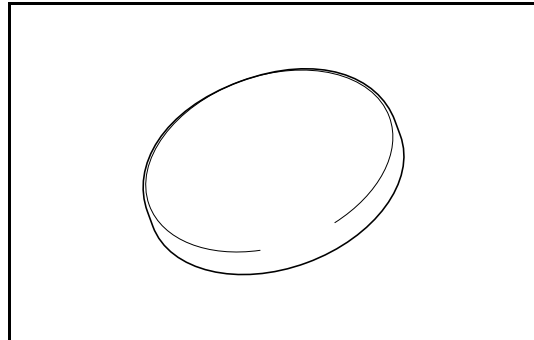

Lens

(3 types, TELE, MIDDLE, WIDE/
with Lens Cap)

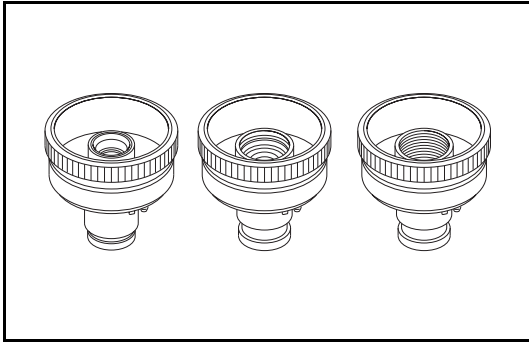

Field Calibration System

(Field Calibration System, Frame for Calibration
System, Hex wrench (M5), 4 screws)

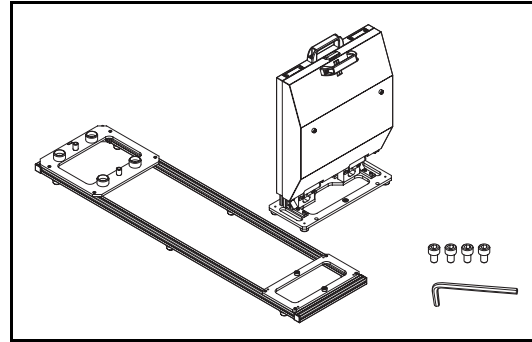

Tripod Attachment Set

(Tripod attachment, Hex wrench (M3), 4
screws)

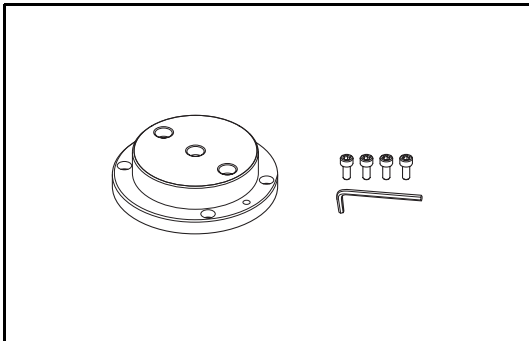

Optional Accessories

When you need to purchase the following optional items, contact a KONICA MINOLTA SENSING-authorized service facility.

Rotary Stage Set

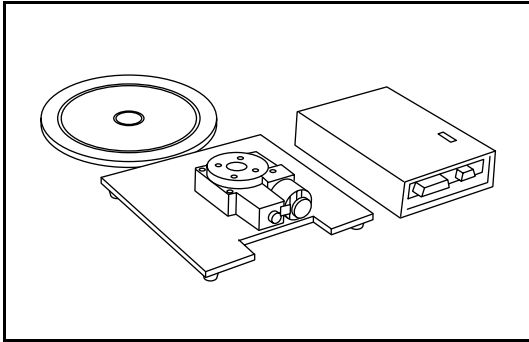

Tripod/Panhead VI-B25

(Pan head, Tripod, Ball Adapter)

System Configuration

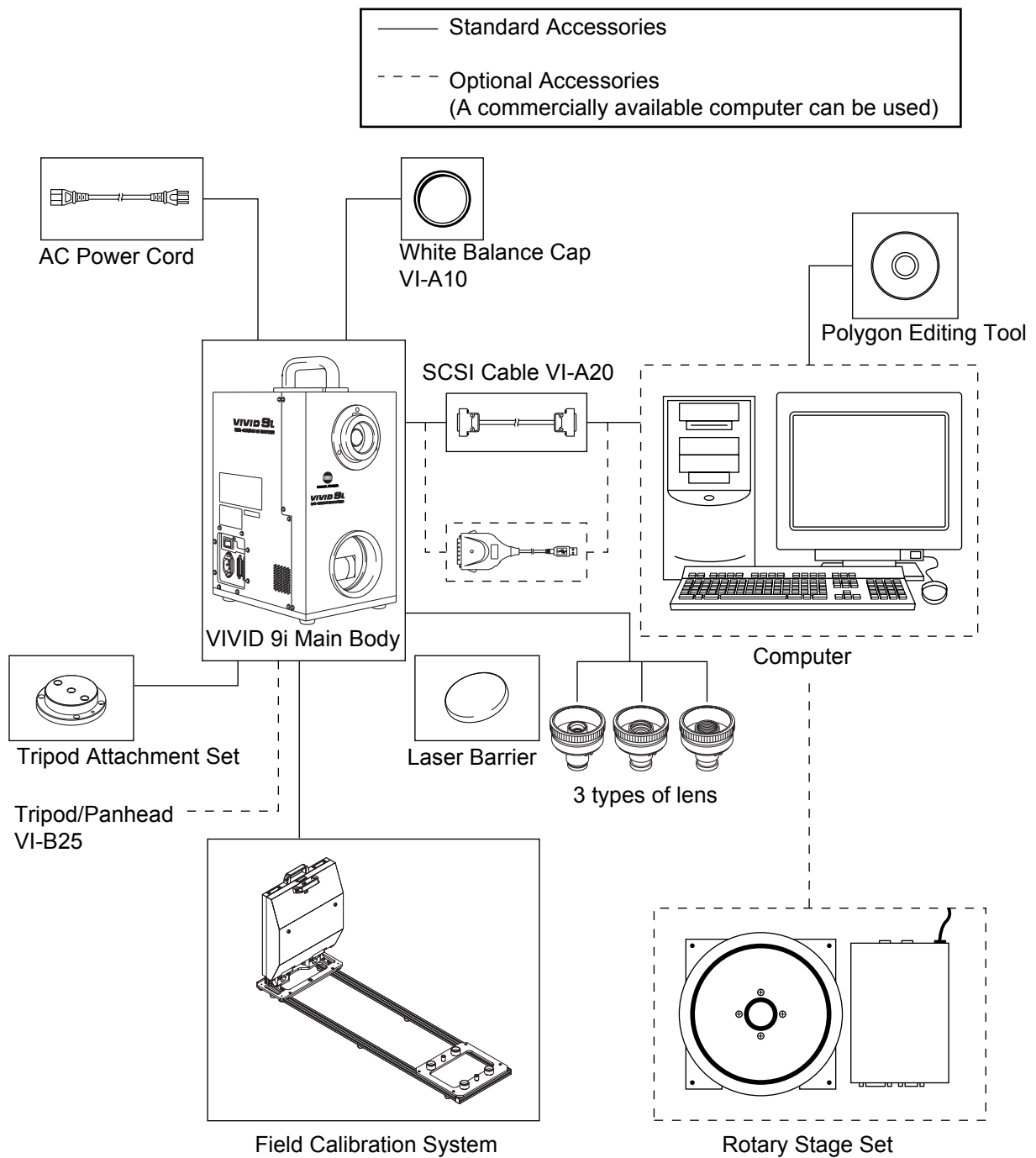

Names and Functions of Parts

Main Body

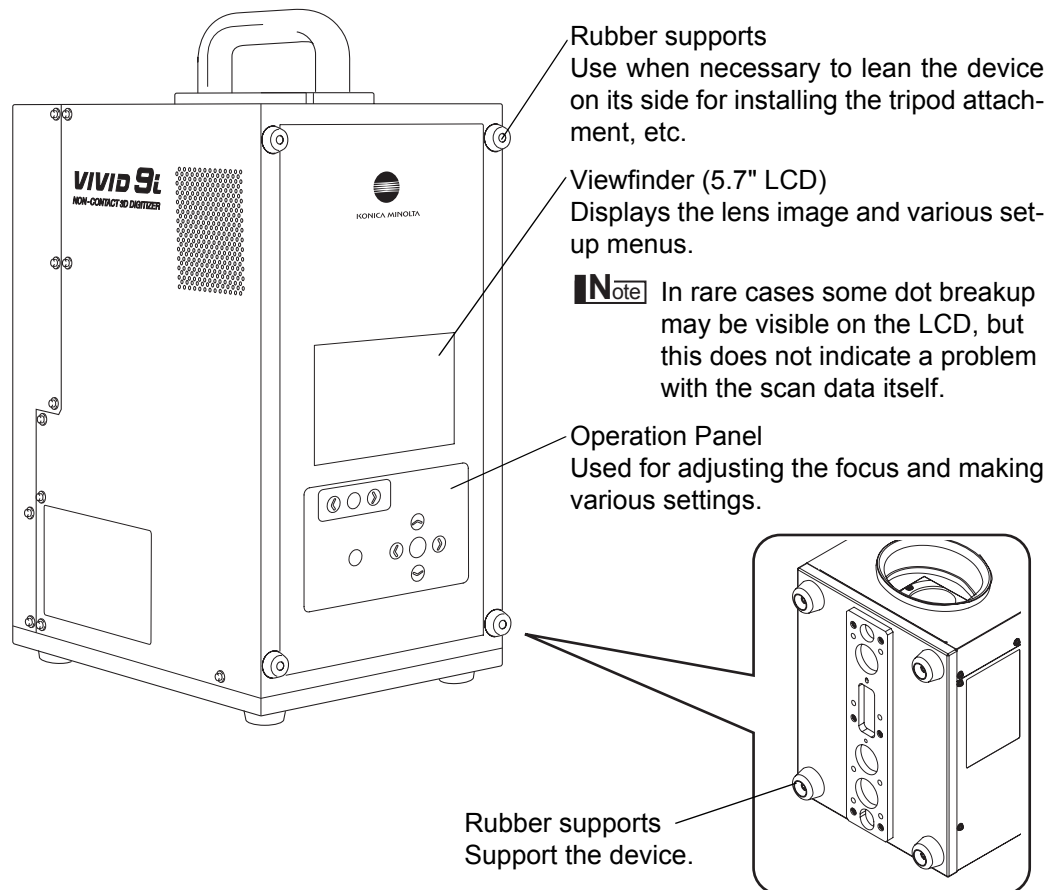
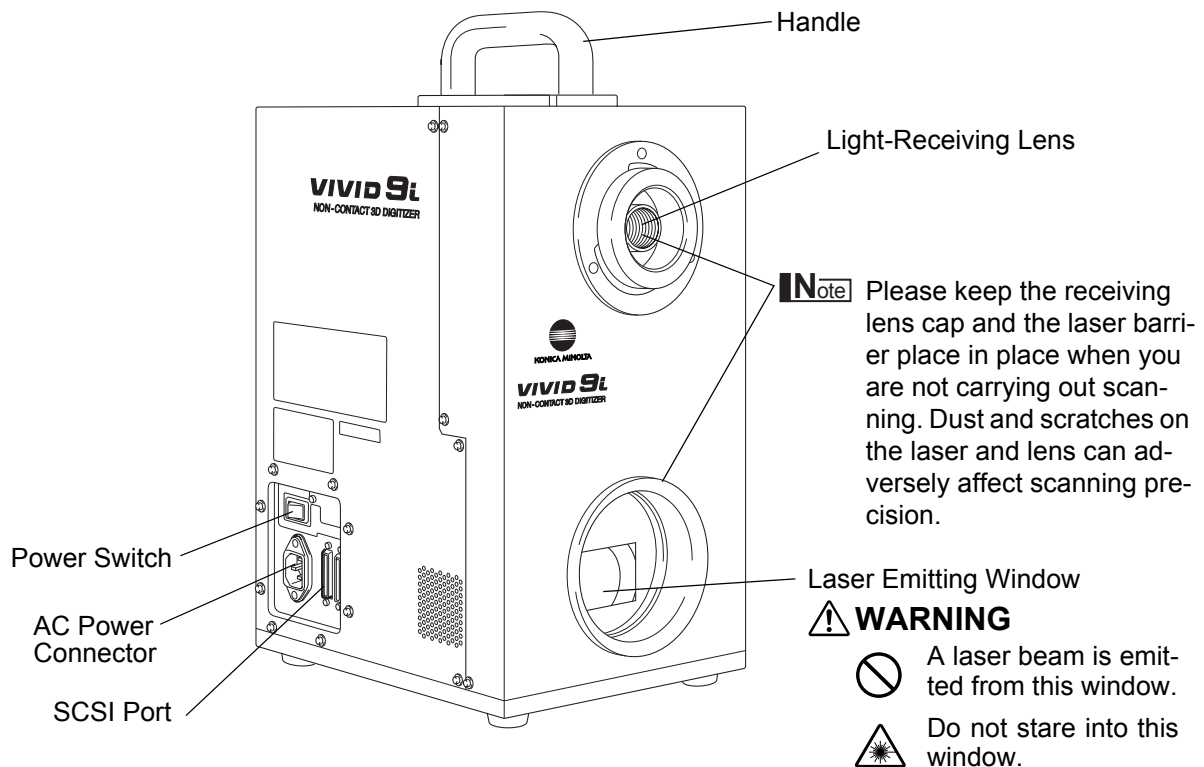

Operation Panel

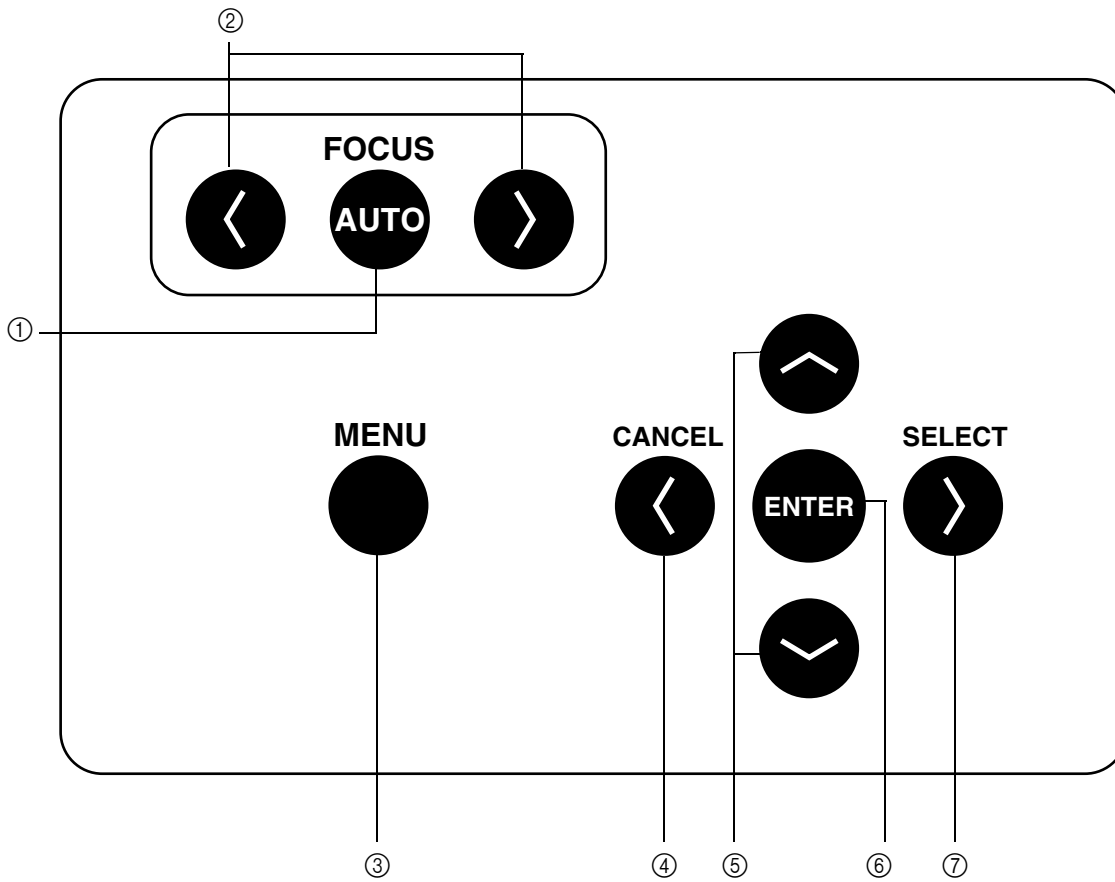

- ① **FOCUS** AUTO Focuses the image automatically.
- ② **◀ (Near) / ▶ (Far)** Focuses the image manually. ▶ indicates “far” and ◀ indicates “near”.
- ③ MENU **●** Press once to display the menu on the viewfinder. Press again to close the menu and return to the monitor image.
- ④ CANCEL **◀** Cancels the current operation and returns to the preceding level.
- ⑤ **▲ ▼** Selects an item at the viewfinder.
- ⑥ ENTER **●** Sets the current selection, and moves to the next level (if any).
- ⑦ SELECT **▶** Moves to the next level for the item currently selected in the viewfinder.

Memo

If you wish to carry out a local operation while the unit is in REMOTE mode (while REMOTE is displayed in the viewfinder): Press any key to cancel REMOTE mode, and then press the appropriate keys for the operation you wish to carry out.

(The MENU view may not be displayed even if MENU **●** is pressed depending on the view currently displayed.)

Chapter 2

Preparation

Connecting the AC Power Cord

To ensure correct connection of the AC power cord, read the points given in **WARNING** and **CAUTION** carefully.

⚠ WARNING

- ❗ Always use the AC power cord supplied as a standard accessory with the VIVID 9i, and connect it to an AC outlet (100-240 V \sim , 50-60 Hz). Failure to do so may damage the VIVID 9i, causing a fire or electric shock.
- ⊘ Do not bend, twist or pull the AC power cord excessively. Do not place heavy items on it, scratch or modify it. Doing so may damage it, resulting in fire or electric shock.
- 🌪 If you are not going to use the VIVID 9i for a long time, disconnect the AC power cord from the AC outlet. If dirt or water accumulates on the prongs of the AC power cord's plug, it may cause a fire. If there is any dirt or water on the prongs, it must be removed.
- ❗ When disconnecting the AC power cord's plug, always hold the plug and pull it to remove it. Never pull the AC power cord itself as it may be damaged, resulting in fire or electric shock. Also do not insert or disconnect the AC power cord's plug with wet hands. Doing so may cause electric shock.

⚠ CAUTION

- ⚡ Plug the power cord into the outlet on the tripod or into a standard outlet. If using a standard outlet, be sure that the ground terminal on the plug is correctly grounded. Improper connection may result in fire or electric shock.
- ❗ Make sure that the AC outlet is located near the VIVID 9i and the AC power cord's plug can be easily connected and disconnected.

[Connecting Procedure]

- 1** Set the power switch of the VIVID 9i to OFF ("O").

Note

If the AC power cord is connected to an AC outlet with the power switch set to ON ("I"), damage to the VIVID 9i or computer may result.

Before connecting the AC power cord, always make sure that the power switch is set to OFF.

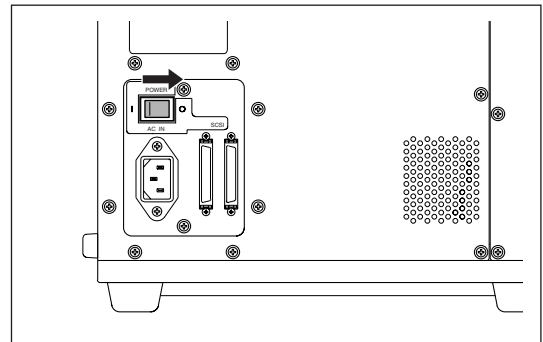

- 2** Plug the AC power cord to the AC power connector on the VIVID 9i.
- 3** Plug the other end of the AC power cord to an AC outlet.

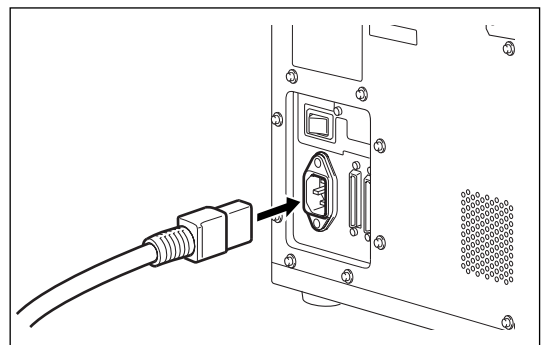

Connecting the VIVID 9i to a Computer

To operate the VIVID 9i from a computer using the Polygon Editing Tool, the VIVID 9i must be connected to the computer with an standard SCSI cable VI-A20.

⚠ WARNING

❗ The computer must be operated correctly and safely according to its instruction manual.

Memo

- The standard SCSI cable has a 50-pin male plug (half-pitch, D-Sub) on both its ends.
- It is also possible to use a commercially available USB adapter. For details, please contact a KONICA MINOLTA SENSING authorized service facility.

Ref. For a description of the standard accessories, refer to page 8.

[Connecting Procedure]

- 1 Set the power switch of both VIVID 9i and computer to OFF (“O”).**

Note

If the AC power cord is connected to an AC outlet with the power switch set to ON (“I”), damage to the VIVID 9i or computer may result.

Always be sure that the digitizer and the computer are both OFF before making connections.

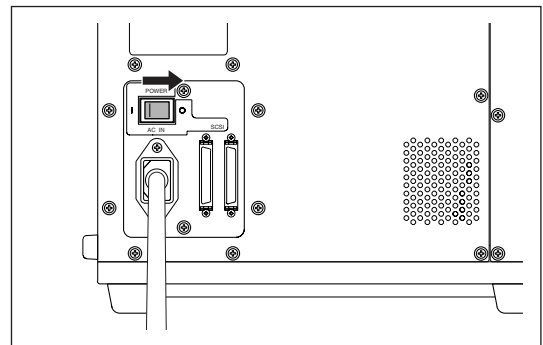

- 2 Plug the SCSI cable to a SCSI port of the VIVID 9i.**

- 3 Plug the other end of the SCSI cable to the SCSI connector of the computer.**

Connecting procedure is now complete

Note

Before turning ON the power to the computer, always turn ON the power to the VIVID 9i and wait until it is ready for operation (see page 21).

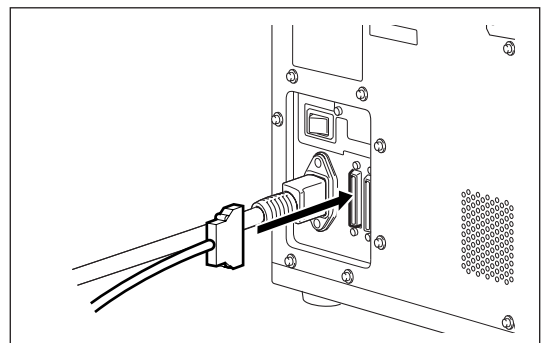

Setting the SCSI ID No.

In order for the computer to recognize that the VIVID 9i is connected to the computer via the SCSI interface, a SCSI ID No. (0 to 6) must be set for the VIVID 9i.













Memo

SCSI ID No. 5 has been set as the default setting before shipment.

Note

If other devices are connected to the computer via the SCSI interface, make sure that the SCSI ID No. of the VIVID 9i differs from those set for the devices.

[Setting Procedure]

- 1 Press . The MENU view will appear.
- 2 Press   to locate the arrow cursor to "SCSI SETTINGS".
- 3 Press  (or ). The SCSI SETTINGS view will appear.
- 4 Press   to locate the arrow cursor to "SCSI ID".
- 5 Press  (or ). The currently selected SCSI ID No. will turn to pink.
- 6 Press   to select the desired SCSI ID No.
 <Settings>
 • 0 to 6: SCSI ID No.
- 7 Press . Setting is now complete.

```
STANDARD 3 HQ ON  NF ON
COLOR OFF
W.B.  DEFAULT
SCSI  5  ENABLED
WHITE BALANCE
INITIAL MODE
INITIAL CONDITION
→SCSI SETTINGS
INFO
```

```
SCSI SETTINGS
→SCSI ID      5
TERMINATE     ENABLED
```

```
SCSI SETTINGS
SCSI ID      6
TERMINATE     ENABLED
```

Note

To cancel the setting and return the SCSI SETTINGS screen to its original state, press .

Setting the Terminator

The VIVID 9i has a built-in SCSI terminator. The terminator is required if the VIVID 9i is the last device of those connected in series to the SCSI interface (i.e., if only one of the SCSI ports on the VIVID 9i is used).

- ❗ If the terminator is not set correctly, the VIVID 9i or devices connected to the SCSI interface may malfunction.











Memo

“ENABLED” has been selected as the default setting before shipment.

Note

“DISABLE” must be selected if the VIVID 9i is connected via the SCSI interface but is not the last device of those connected in series, and “ENABLE” must be selected if it is not connected via the SCSI interface.

[Setting Procedure]

- Press .
The MENU view will appear.
- Press   to locate the arrow cursor to “SCSI SETTINGS”.
- Press  (or ).
The SCSI SETTINGS view will appear.
- Press   to locate the arrow cursor to “TERMINATE”.
- Press  (or ).
The currently selected option (ENABLED or DISABLED) will turn to pink.
- Press   to select “ENABLED” or “DISABLED”.

```
STANDARD 3 HQ ON  NF ON
COLOR OFF

W.B.  DEFAULT
SCSI  5  ENABLED

WHITE BALANCE
INITIAL MODE
INITIAL CONDITION
→SCSI SETTINGS
INFO
```

```
SCSI SETTINGS
SCSI ID      5
→TERMINATE  ENABLED
```

```
SCSI SETTINGS
SCSI ID      5
TERMINATE    ENABLED
```

<Settings>

- **ENABLED:** Select this option if the terminator is to be used.
- **DISABLED:** Select this option if the terminator is not to be used.

7 Press ^{SELECT} ● .
Setting is now complete.

Note

To cancel the setting and return the SCSI SETTINGS screen to its original state, press ^{CANCEL} ● .

Starting and Quitting

Starting the VIVID 9i

[Operating Procedure]

- 1 Set the power switch to ON (“|”).**

Power will be supplied to the VIVID 9i and initial set-up is performed. After several dozen seconds, “PLEASE OPEN LASER BARRIER AND PRESS ANY KEY” will be displayed on the viewfinder.

Note

When turning power ON again after it has been turned OFF, wait at least 5 seconds before doing so. Failure to observe this may result in malfunction or breakdown of the VIVID 9i.

Memo

To ensure precise measurement, allow the unit to warm up for at least 10 minutes.

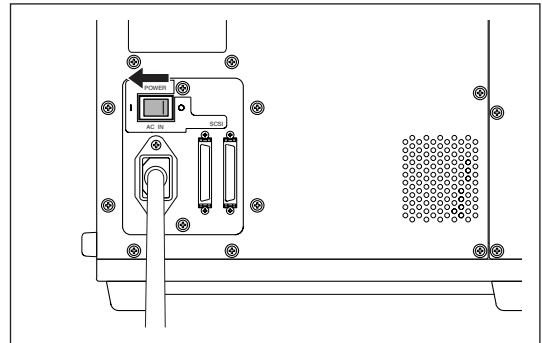

- 2 Remove the lens cap from the receiving lens.**

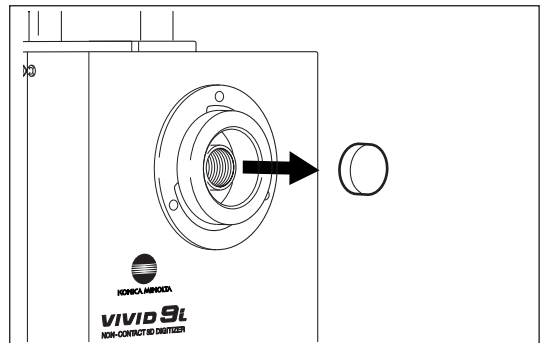

- 3 Remove the laser barrier.**

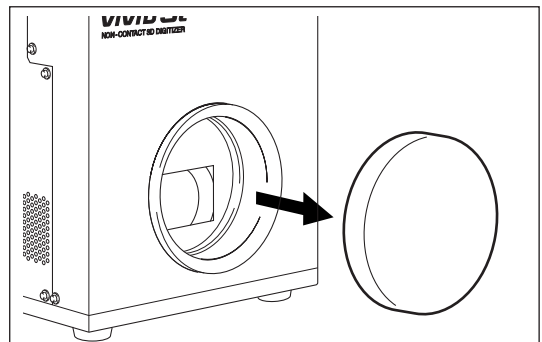

4 Press any key.

The MONITOR view will appear, indicating that the VIVID 9i is now ready for operation.

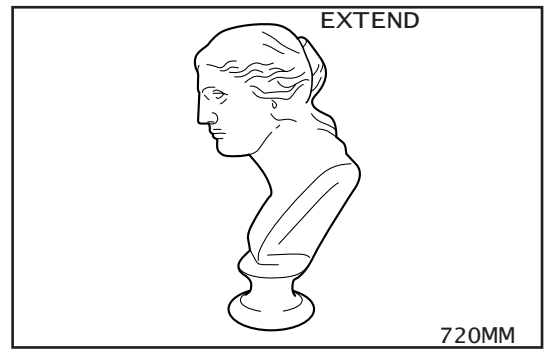

Quitting the VIVID 9i

[Operating Procedure]

- 1 Set the power switch to OFF (“○”).
Power will be turned OFF.

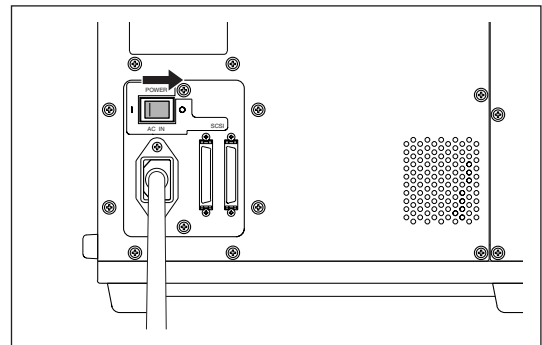

- 2 Attach the lens barrier.

⚠ WARNING

⚠ To ensure safety, please keep the lens barrier in place at all times when the unit is not in use.

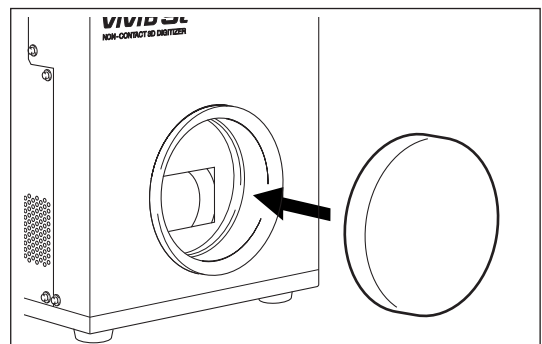

- 3 Fit the lens cap onto the receiving lens.

Note

Please keep the receiving lens cap and the laser barrier in place when you are not carrying out scanning. Dust and scratches on the laser and lens can adversely affect scanning precision.

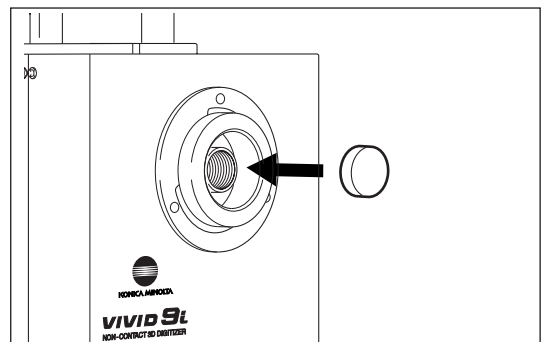

Mounting to the Tripod

When using the instrument with the tripod, first attach the tripod attachment to the instrument, and then attach the instrument to the panhead/tripod.

CAUTION

- Make sure that the tripod attachment, panhead and tripod are secured to the instrument and each fastener on the tripod is firmly tightened. Failure to observe this point may result in the tripod overturning or the instrument dropping.
- When placing the tripod on a floor, examine the floor conditions and flatness to make sure that the tripod is stably placed.
- After measurement is completed, the instrument must be removed from the tripod before storing them. If the instrument is stored with the tripod attached, the tripod may overturn or the instrument may drop, resulting in accidents.

1. Mounting the Tripod Attachment to the Instrument

Before mounting the instrument to the tripod, mount the tripod attachment to the instrument as explained below.

Memo

Four screw holes for the tripod attachment are provided on base of the instrument.

[Operating Procedure]

- 1** After checking to ensure that you have turned off the power to the both the digitizer and computer, disconnect the digitizer's power cord and the SCSI cable.

Note

Note that disconnection of cables while power is ON may result in damage to the digitizer and/or the computer. Be sure to turn off power at both sides before disconnecting cables.

- 2** Slowly lean the digitizer over on a flat and stable surface, so that it is lying on the rubber supports on its rear side.

- 3** Place the tripod attachment on the base of the instrument, and secure it with the four screws (supplied with the tripod attachment).

Note

Align the tripod attachment and digitizer so that the projecting area of the attachment fits into the receding area on the base of the digitizer.

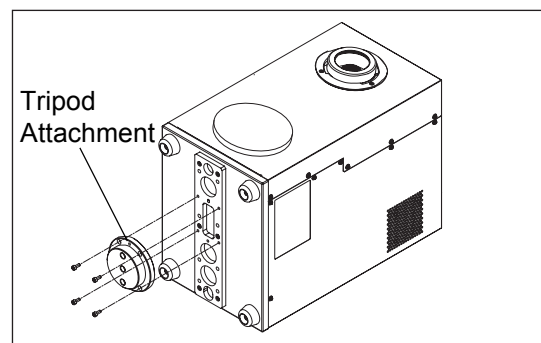

2. Mounting the Instrument to the Panhead

After you have attached the tripod attachment to the instrument, they need to be mounted to the recommended panhead as explained below.

First, remove the accessory plate from the panhead, attach it to the instrument, then attach both to the panhead.

Memo

Three screw holes are provided on the back of the tripod attachment, to allow mounting the tripod attachment to the panhead.

[Operating Procedure]

1 Remove the accessory plate from the panhead.

2 Place the top of the accessory plate on the tripod attachment (attached to the instrument), and secure them with two screws (U3/8, supplied with the accessory plate).

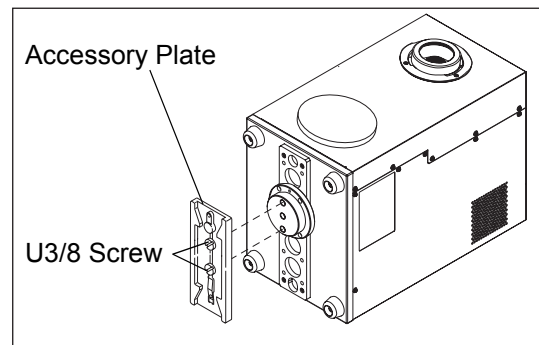

3 Make sure that the tripod/panhead is secured in place.

4 Slide the accessory plate (attached to the tripod attachment on the instrument) into the panhead.

Memo

Slide and attach the plate from front of the panhead.

5 Tighten the slide fixing knob to firmly secure the accessory plate to the panhead.

Memo

Refer to the tripod/panhead instruction manual for details on using the accessory plate locking knob.

Chapter 3

Operation



Replacing the Lens and Field Calibration

With the VIVID 9i, three types of lens are available: WIDE lens, MIDDLE lens and TELE lens. Be sure to mount the lens that best matches the subject's size and distance. Before taking scans of a subject, most suitable lens for the size of the object and distance must be used.

Note

After changing the lens, you need to recalibrate using the field calibration system. For Field Calibration, refer to page 32.

Relationship between Measurement Distance and Object

Select the most suitable lens by referring to the table given below.

Memo

The closer the object to the VIVID 9i, the higher the measurement accuracy is. On the other hand, influences of shades produced due to roughness on the surface of the object can be reduced if the object is positioned far from the VIVID 9i.

WIDE Lens

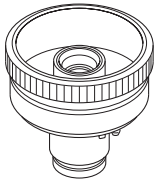

Measurement Distance		500	600	800	1000	2500
Object Size	Horizontal	299	359	478	598	1495
	Vertical	224	269	359	449	1121

Unit (mm)

MIDDLE Lens

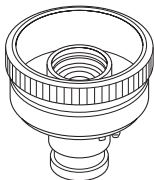

Measurement Distance		500	600	800	1000	2500
Object Size	Horizontal	165	198	263	329	823
	Vertical	124	148	198	247	618

Unit (mm)

TELE Lens

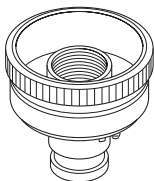

Measurement Distance		500	600	800	1000	2500
Object Size	Horizontal	93	111	148	185	463
	Vertical	69	83	111	139	347

Unit (mm)

Replacing Procedure

You can use the status information to see what type of lens is currently attached. The lens type is also written on the lens itself.

The explanation below assume that the power to the digitizer is ON, but note that it is also possible to change the lens while the power is OFF. If the power is OFF, however, you cannot use the digitizer's viewfinder or control keys.

[Ref.] For display of the status information, refer to page 44.

[Note]

- *Only the lenses supplied as standard accessories with the VIVID 9i can be used. (They are not compatible with other VIVID models since they have been calibrated with the VIVID 9i only.)*
- *Since the VIVID 9i is a precision instrument, do not leave it without lens when replacing the lens. Replace the lens as soon as possible.*
- *Do not touch the lens surface with fingers.*
- *Dust and scratches on the lens surface may adversely affect precision. When not using the digitizer, keep the lens cap on the lens. If the lens is dusty, clean it with a camera blower.*
- *Dust or dirt on the lens mount surface may produce incorrect measurement data. In this case, wipe the lens mount surface with a clean, dry cloth and then blow it with a camera air blower etc.*
- *Dust and dirt collected on the lens mount surface on the body side must also be removed with a camera air blower etc.*
- *SCSI communication is not available while the lens is being replaced. Please close the Polygon Editing Tool software's control dialog before starting replacement.*

[Operating Procedure]

1 Remove the lens hood.

Turn counterclockwise to align with the cutouts.

[Memo]

The lens hood can be fixed with its bayonet mount.

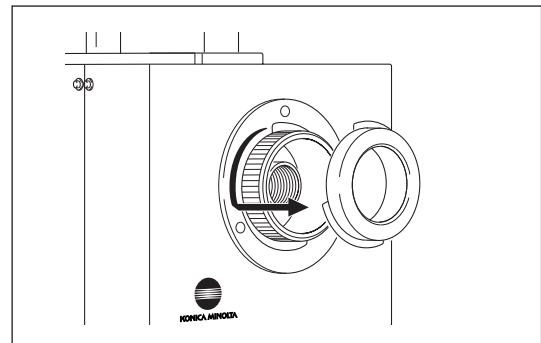

2 Turn the lens fixing ring counter-clockwise to loose it completely.

[Memo]

The lens fixing ring can be fixed with its screw mount.

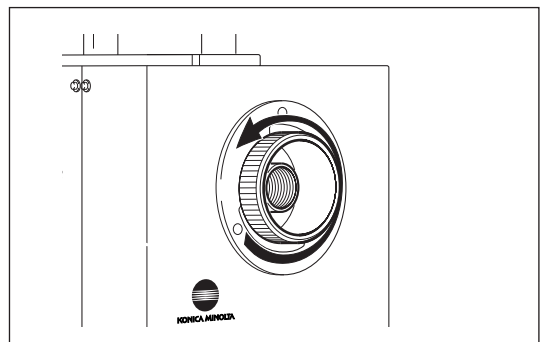

3 Hold the external edge of the fixing ring and pull it out.

[Memo]

Hold the ring with your finger located near the red mark on the lens. This will facilitate pulling the lens.

[Note]

Attach the lens cap to the removed lens, place it in the lens case and keep it in a safe place.

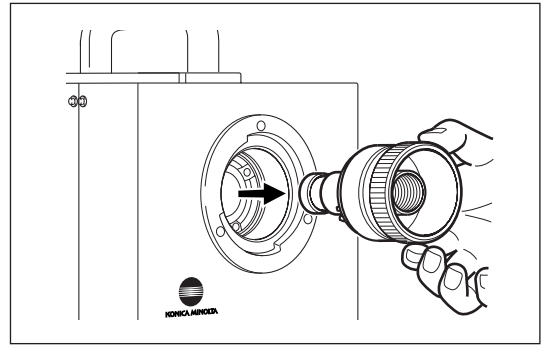

The following information will appear in the viewfinder as shown on the right.

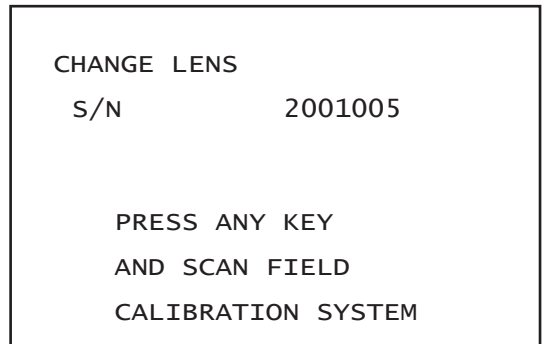

4 Attach the desired lens.

- Remove the lens cap.
- Align the red mark on the lens with the one on the lens mount socket, and insert the lens until a click is heard.

[Memo]

Hold the ring with your finger located near the red mark on the lens. This will facilitate inserting the lens.

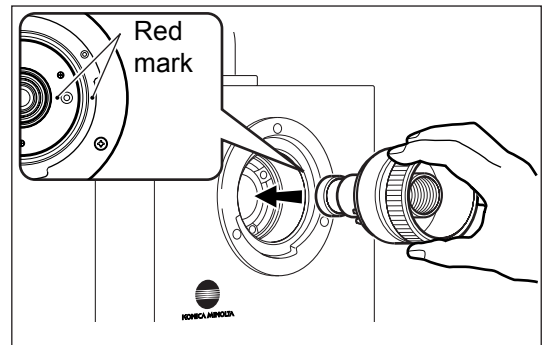

5 Turn the lens fixing ring clockwise to secure the lens.

[Note]

After tightening the lens, make sure that the red mark on the ring is aligned with the red mark on the body.

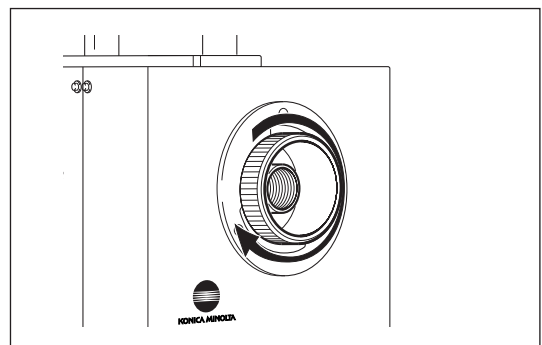
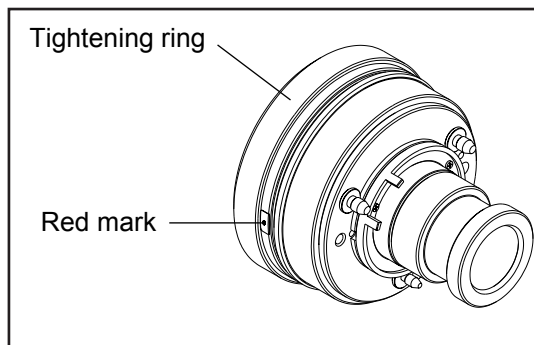

6 Attach the lens hood.

Align the cutouts, and then turn clockwise.

[Memo]

The hood must be turned until it contacts the bayonet mount socket.

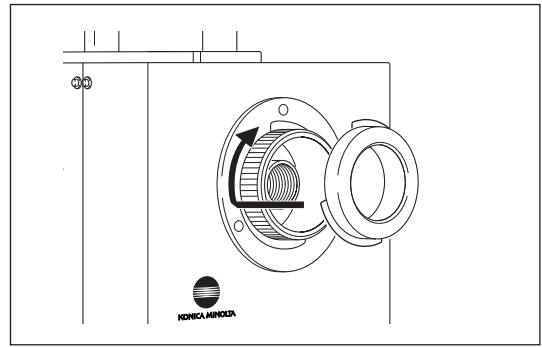
**7 Press any key.**

After several dozen seconds, “PLEASE OPEN LASER BARRIER AND PRESS ANY KEY” will be displayed on the viewfinder.

8 Press any key.

The viewfinder displays the monitor screen, and the digitizer is ready for use.

[Note]

Place a lens cap on the lens you removed, put it in its case, and store in a safe place.

9 Use the field calibration system and the Polygon Editing Tool software to calibrate the system.**[Ref.]**

For the field calibration procedure, refer to “Field Calibration” on the next page.

Field Calibration

The field calibration on this unit is done using the Field Calibration System. Periodic field calibration is recommended to maintain measurement precision.

Note

- Always carry out field calibration when changing lenses.
- The Field Calibration System that corresponds to the type of lens the unit is equipped with must be used when conducting field calibration.
- This unit and the Field Calibration System are paired, so it is not possible to correctly calibrate it when the serial numbers differ. Use the unit and Field Calibration System combination that have the same serial number.

Memo

The type of lens the unit is equipped with and the serial number of the unit can be confirmed in the Status information.

Ref For details on displaying the status information, refer to page 41.

Field Calibration System

The Field Calibration System is comprised of the Unit Section which contains the Field Calibration System, which corresponds to the type of lens on the unit, and the Frame Section, which maintains a facing position at a set distance from the unit.

- Parts Nomenclature

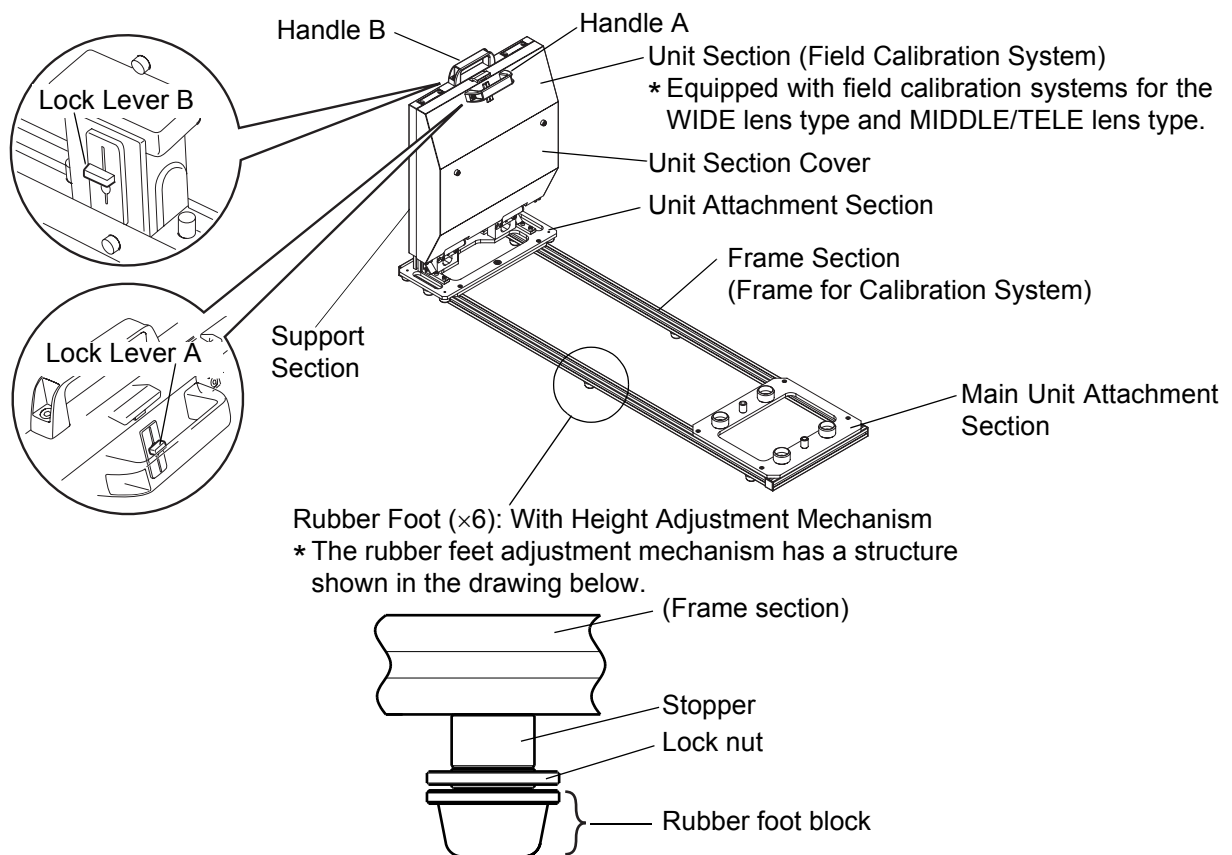

[Specifications]

- Lowest height: 43mm
- Adjustable range: Max. 10mm (with no preventive structure)

- Installation Space

A secure installation location that meets the dimensional requirements as shown in the drawing below is necessary to install the Field Calibration System. Before using the Field Calibration System, a “Calibration Area” for stable and high quality calibration is required, in addition to the place that is necessary to position the Field Calibration System.

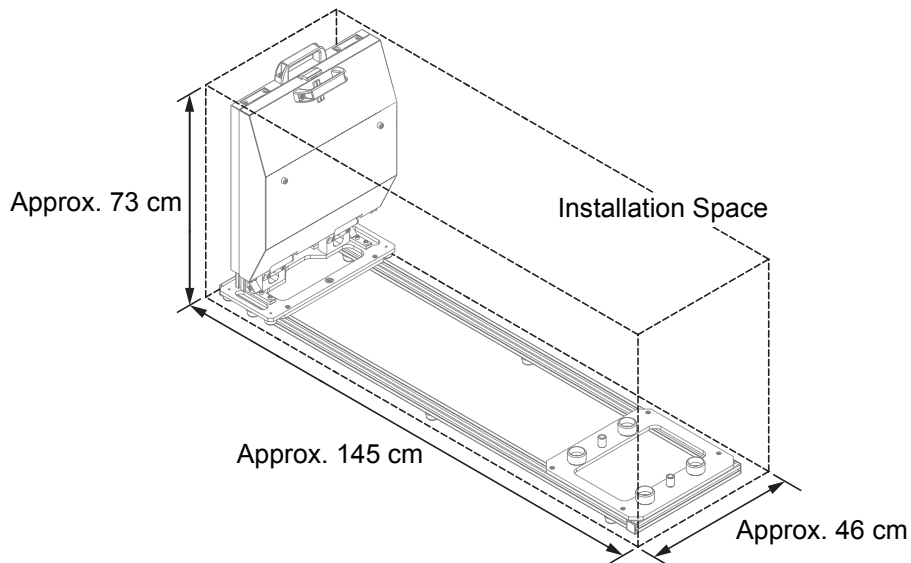

- Calibration Area

The “Calibration Area” is the box shaped area shown in the drawing below.

The dimensions are:

- 30 cm or less in front of or behind the Chart unit
- 20 cm or less right or left to the Chart unit
- 20 cm or less above the Chart unit

Note

- *Prevent foreign matter from getting into the “Calibration Area”. When executing Field Calibration, do not allow workers into the area. It may result in incorrect calibration.*
- *Be careful to block incident light from the outside. Execute Field Calibration under fluorescent light at less than 500lx.*
- *Prevent light from windows.*

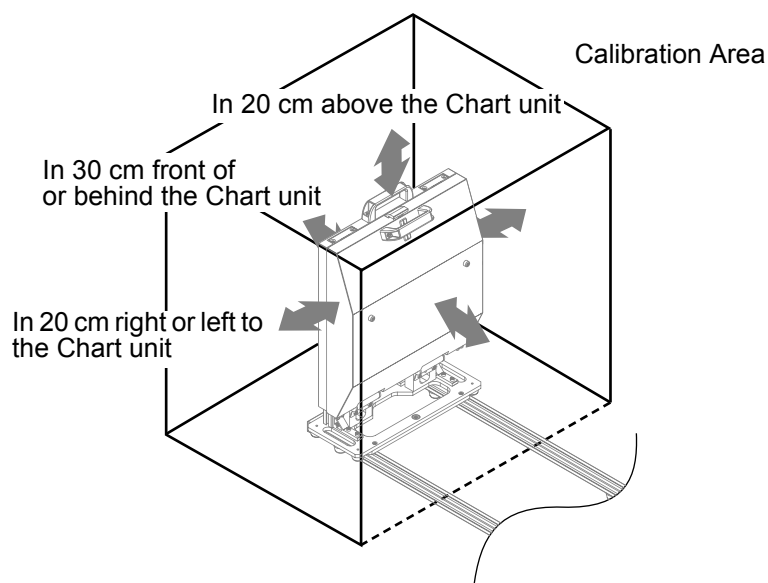

Executing Field Calibration

The Field Calibration System is made up of the Field Calibration System Section and the Frame Section. It is necessary to assemble it when it is to be used for the first time or after it has been temporarily disassembled to move the Field Calibration System, etc. In addition, it is necessary to attach the Field Calibration System to the main unit in order to carry out field calibration.

[Memo]

VIVID 9i/VI-9i has been calibrated at 20°C. The allowable operating environment is 10°C to 40°C, but we recommend that you execute Field Calibration or scan the objects in environments where ambient temperature is 20°C (68°F).

Assembling the Field Calibration System

[Procedure]

1 Install the Frame Section.

Install the Frame Section in a secure location with sufficient space.

[Note]

For the place that is necessary to install the Frame of the Field Calibration System, see page 33 of this instruction manual. A "Calibration Area" is also required for executing the calibration.

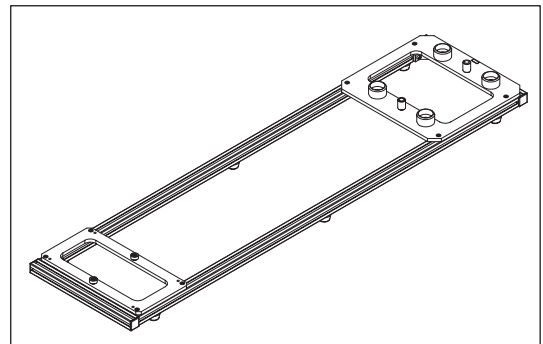

2 Adjust the Height of Rubber Feet to Stabilize the Frame Section.

The Frame of the Field Calibration System is designed to be used on a sufficiently wide, stable, flat surface. However, even if a sufficiently wide space is available, the surface may not be completely flat, resulting in one or more of the rubber feet of the frame not being in contact with the surface. To solve this problem, the feet have been equipped evenly with a mechanism to allow their height to be adjusted.

[Memo]

All 6 rubber feet have height adjustment mechanisms.

[Note]

- *Adjust a height of the rubber feet without any item on the frame during the procedure for setting up the frame of this system.*
- *When transporting this system, set the rubber feet to their lowest height to avoid damage to the shopping box.*

- ① Turn the lock nut counterclockwise to unlock the rubber foot block.

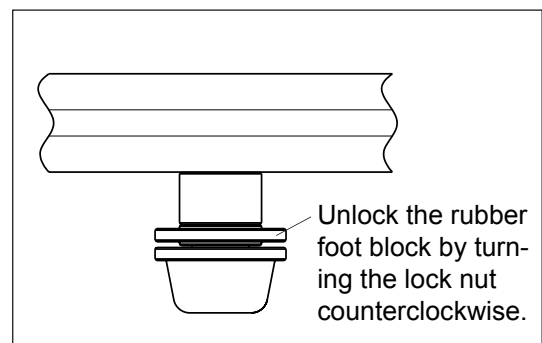

- ② Turn the lock nut counterclockwise to unlock the rubber foot block.

[Memo]

Turn clockwise for lower heights and counterclockwise for higher heights.

[Note]

Because there is no preventive structure, moving the rubber foot block more than adjustable range may cause the rubber foot block to fall off. In this case, screw the rubber foot block onto the stopper unit clockwise.

- ③ After adjusting the height correctly, move the lock nut to the stopper unit by turning it clockwise and lock the rubber foot block.

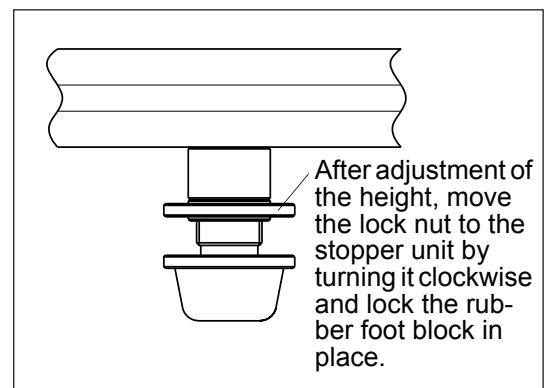
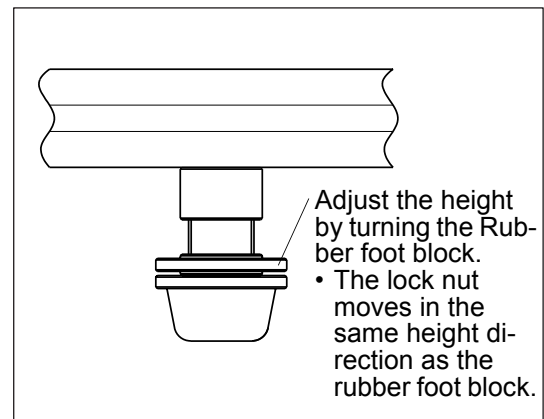

3 Attach the Unit Attachment Section to the Field Calibration System Unit Section.

Use the 4 screws and tighten them firmly with the included hex wrench.

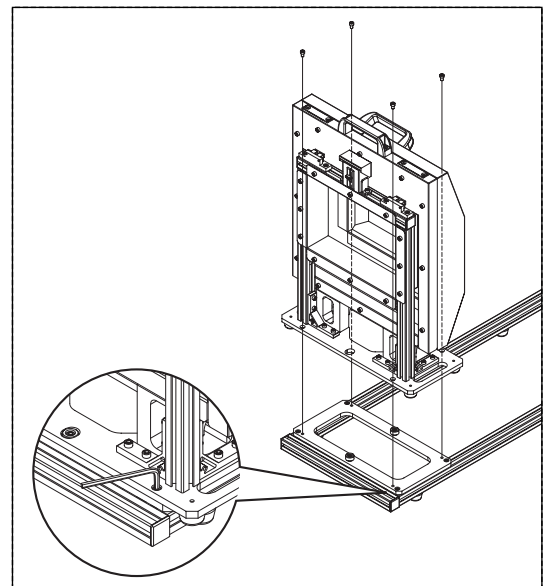

4 Attach the VIVID 9i Attachment Section to the main unit.

Make sure the footings at the base of the main unit are inserted into the 4 footing seats.

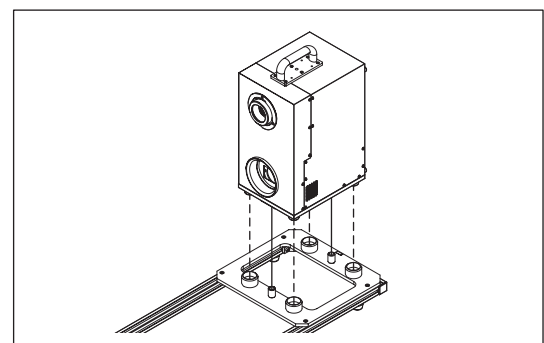

Field Calibration System Preparation

There are two types of field calibration systems: one for WIDE lens type use and the other for MIDDLE/TELE lens type use. Use the Field Calibration System that corresponds to the type of lens the main unit is equipped with.

[Procedure]

- Preparing the Wide Lens Field Calibration System

1 Open the cover of the Field Calibration System Unit Section.

- ① Pull Lock Lever A down to the UNLOCK position.
- ② Grasp Handle A and Handle B with both hands and pull to spread open.

Note

There may be instances where the Field Calibration System for the WIDE lens will slightly jut out when the Unit Section Cover is opened.

When using the Field Calibration System for the WIDE lens, gently push on it to return the Field Calibration System to the unit side.

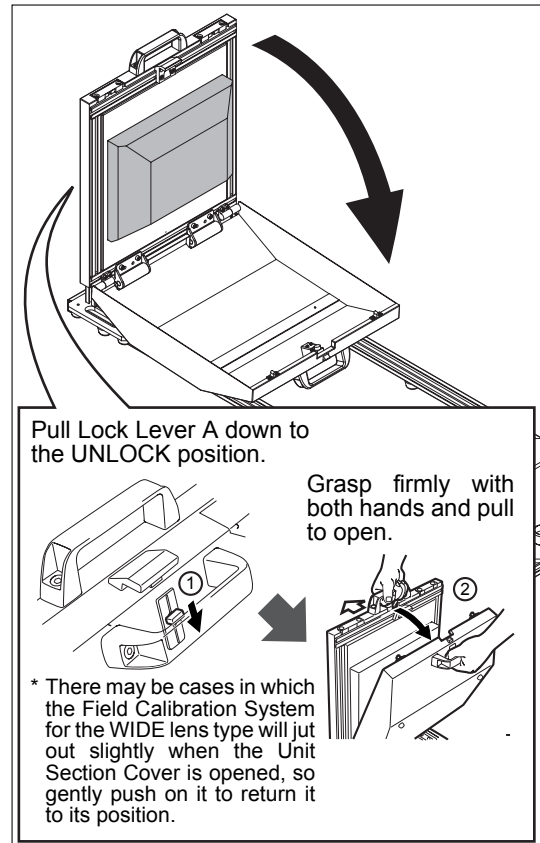

- Preparing the MIDDLE/TELE Lens Field Calibration System

1 Open the Field Calibration System Unit for the WIDE lens.

- ① Pull Lock Lever B down to the UNLOCK position.
- ② Grasp Handle B and the Support Section of the Field Calibration System Section using both hands and pull to spread open.

Memo

The Field Calibration System for the MIDDLE/TELE lens may be opened using the procedure for opening the Field Calibration System unit for the WIDE lens or it may be opened by opening the Unit Section Cover and then opening the Field Calibration System for the WIDE lens.

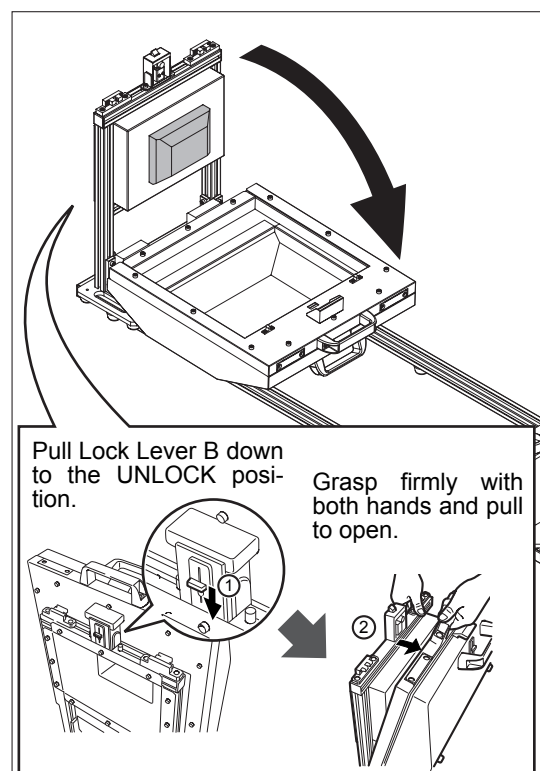

Executing Field Calibration

Field Calibration on this unit is carried out using the Polygon Editing Tool Software. After the assembly of the Field Calibration System has been completed and the unit connected to a PC and powered on, it will be necessary to start up the Polygon Editing Tool software.

Note

- Prevent foreign matter from getting into the “Calibration Area”. When executing Field Calibration, do not allow workers into the area. It may result in incorrect calibration.
- Be careful to block incident light from the outside. Execute Field Calibration under fluorescent light at less than 500lx.
- Prevent light from windows.

Ref. For details, refer to page 13, in the Polygon Editing Tool Instruction Manual.

[Procedure]

1 At the [File] menu, click [Select Digitizer].

2 Select [VIVID9i (VI-9i)], and click [OK].

Note

If you change the selection from one digitizer to another at this dialog, the newly selected digitizer cannot be used until you start the software again.



3 At the [File] menu, click [Exit] to close the software. Then start the software again.

Note

You can skip this step if “none” was originally selected when you opened the Select Digitizer dialog at Step 2 above.

4 At the [File] menu, select [Import-Digitizer], and click [One Scan] or [Step Scan].

The software opens the [File-Import-Digitizer-One Scan] or [File-Import-Digitizer-Step Scan] dialog. The dialog's work window shows a field calibration image.

Memo

There is a possibility that the image of the Field Calibration Chart is displayed out of center in the Work window of the dialog box or the finder of the instrument due to individual differences of the VIVID 9i/VI-9i or Field Calibration System. It does not have an effect on the result of Field Calibration.

Note

If the image of the Calibration Chart isn't displayed in the angle of the VIVID 9i/VI-9i's finder or Work window of the dialog box of the Polygon Editing Tool, setting of Field Calibration Chart or the instrument might be incorrect. Reinstall them correctly again.

(The following example is from the [File-Import-Digitizer-One Scan] dialog.)

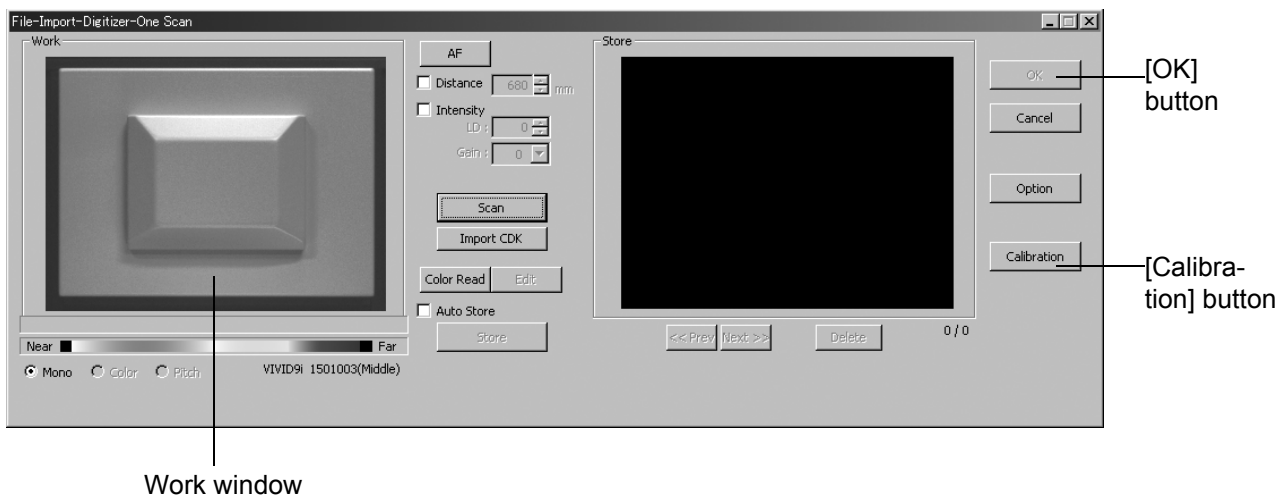

5 Click the [Calibration] button.

The system carries out field calibration.

6 Check that field calibration was successful.

If you are using field calibration results to measure the dimensions of the field calibration system, the software shows the differences from the measurements made at time of shipping. Differences are shown for four places: X1, Y1, X2, and Y2.

- If field calibration was not successful, one of the following messages appears. Proceed in accordance with the displayed message.

Message	Meaning	What To Do
Field Calibration: Scan Error	Failed to recognize the field calibration system.	<ul style="list-style-type: none"> • Remove the laser barrier and the receiving lens cap. • Check that you are using the correct system type for the lens used. • Check that foreign matter is not in the “Calibration Area”. • Check that there is no effect of light from outside. • Be sure that the Field Calibration Chart unit is correctly mounted to the Frame section. • Check that the image of the Field Calibration Chart is correctly displayed in the view angle of the finger of the VIVID 9i/VI-9i or the Work window of the dialog box of the Polygon Editing Tool.
Field Calibration: Evaluate Error	Failed to correctly measure the field calibration system.	<ul style="list-style-type: none"> • Check that you are using the correct system type for the lens used. • Check that foreign matter is not in the “Calibration Area”. • Check that there is no effect of light from outside. • Be sure that the Field Calibration Chart unit is correctly mounted to the Frame section. • Check that the image of the Field Calibration Chart is correctly displayed in the view angle of the finger of the VIVID 9i/VI-9i or the Work window of the dialog box of the Polygon Editing Tool.
Field Calibration: Calibrate Error	Adequate field calibration results cannot be obtained.	<ul style="list-style-type: none"> • Remove the lens, and then set it again correctly. • Check that foreign matter is not in the “Calibration Area”. • Check that there is no effect of light from outside. • Be sure that the Field Calibration Chart unit is correctly mounted to the Frame section. • Check that the image of the Field Calibration Chart is correctly displayed in the view angle of the finger of the VIVID 9i/VI-9i or the Work window of the dialog box of the Polygon Editing Tool. • When multiple units of the instrument are used, check to make sure that the Field Calibration System matches the serial number of the instrument. • If there is any dirt on the laser window or the receiving lens, clean these as explained on page 3. • Clean off any dust on the field calibration system. • If the field calibration system is scratched or dented, contact a KONICA MINOLTA SENSING authorized service facility. • If the same error recurs when you retry the field calibration, contact a KONICA MINOLTA SENSING authorized service facility.

7 Click the [Cancel] button.

The dialog closes, and field calibration is completed.

Ending Field Calibration

After the field calibration is finished, remove the unit from the Field Calibration System. Also close the Field Calibration System that was used and return it to its original condition.

[Procedure]

1 Remove the unit from the Attachment Section of the main unit.

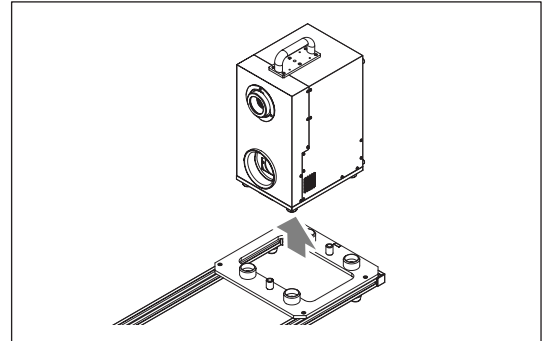

2 Close the Field Calibration System.

Note

- *Be careful not to pinch your fingers in the opening and closing section when you shut the Field Calibration System.*
- *The Field Calibration System may be degraded if left open. Always close and store the Field Calibration System after use.*
- *In the case where the MIDDLE/TELE lens type Field Calibration System has been opened after opening the WIDE lens type Field Calibration System, the Field Calibration System for the WIDE lens type and the Unit Section Cover will be separated so be sure to close the Unit Section Cover only after closing the WIDE lens type Field Calibration System.*

① Close the Field Calibration System for the MIDDLE/TELE lens type.

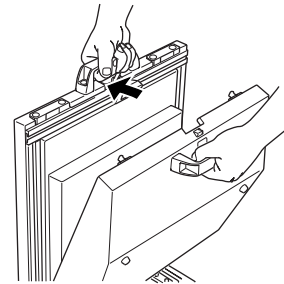

② Close the Field Calibration System for the WIDE lens type.

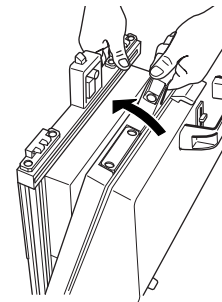

* In the case where the MIDDLE/TELE lens type Field Calibration System has been opened after opening the WIDE lens type Field Calibration System, first close the WIDE lens type Field Calibration System and then close the unit section cover.

The Field Calibration System can be stored as is, without disassembling it into the Field Calibration System Unit Section and the Frame Section.

In the case where the system has to be disassembled and stored for reasons related to installation space requirements or to move or transport it, follow the procedure outlined below to disassemble it.

Disassembling the Field Calibration System

In cases where the Field Calibration System needs to be disassembled to move or transport it or for reasons related to its installation space, separate the Field Calibration System into the Field Calibration System Unit and the Frame sections.

Note

Do not disassemble any sections that are not covered in this document. Doing so may lead to a reduction in precision.

[Procedure]

1 Remove the Unit Attachment Section from the Field Calibration System Unit Section.

Use the included hex wrench to remove the 4 screws.

Memo

Carefully store the screws that are removed with the Field Calibration System Unit Section.

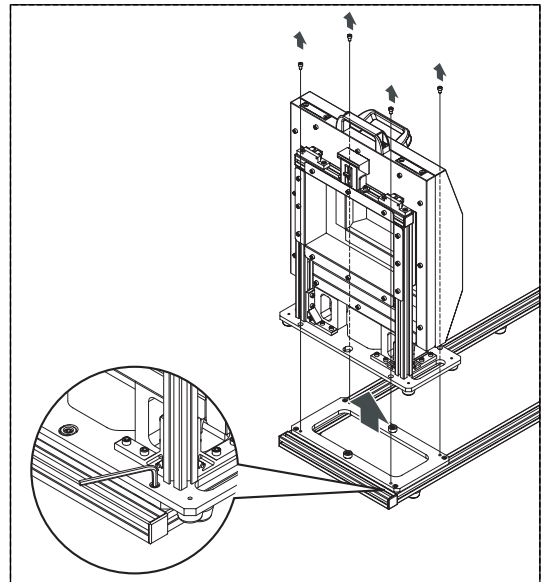

2 Store the Field Calibration System Unit Section and the Frame Section in an appropriate place.

Note

- *Do not store the Frame Section in an upright position.*
- *Store the Field Calibration System Section in a closed condition.*
- *Even when 2 or more persons are available to move or transport the Field Calibration System, always disassemble it before attempting to move it.*

Adjusting the White Balance

The color of an object varies slightly depending on the type of light source. To acquire accurate color image data, adjust the white balance as described below under the light source to be used.

When scanning, we recommend that you use a stable, flicker-free light source (such as a high-frequency fluorescent lamp).

Memo

The white balance has been adjusted under fluorescent light before shipment.

[Operating Procedure]

1 Set the light source so that the lighting condition is the same as that under which scan is to be performed.

2 Attach the white balance cap to the VIVID 9i as illustrated.

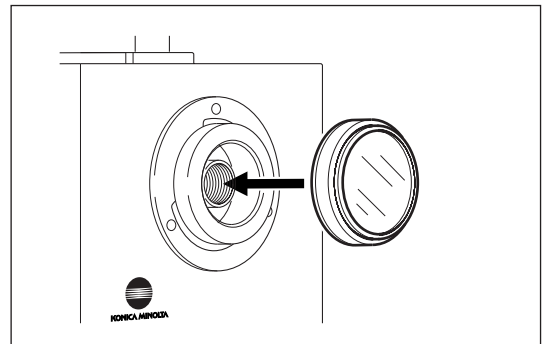

3 Press **MENU** ●.
The MENU view will appear.

4 Press **▲▼** to locate the arrow cursor to "WHITE BALANCE".

STANDARD 3 HQ ON NF ON
COLOR OFF

W.B. DEFAULT
SCSI 5 ENABLED

→WHITE BALANCE

INITIAL MODE

INITIAL CONDITION



SCSI SETTINGS

INFO

5 Press  (or ).
The WHITE BALANCE view will appear.



WHITE BALANCE DEFAULT

6 Press   as necessary to select one of the following settings.

<Setting>

- DEFAULT: Adjusts for fluorescent light.
- USER'S: Uses the previously adjusted white balance.
- CALIBRATION: Adjusts white balance automatically.

7 Press .

If [CALIBRATION] was selected, the digitizer displays the screen shown at right and automatically adjusts the white balance. When adjustment is complete, the display returns to the Menu screen. The adjusted white balance is saved into USER'S.

If DEFAULT or USER'S was selected, adjustment is completed and the display returns to the Menu page.







CALIBRATING

Displaying the Status Information

The model name, version, lens, field calibration system information can be displayed.

[Operating Procedure]

- 1 Press .
The MENU view will appear.
- 2 Press   to locate the arrow cursor to "INFO".
- 3 Press  (or ).
The status information will be displayed as shown below.

```
STANDARD 3 HQ ON  NF ON
COLOR OFF

W.B.  DEFAULT
SCSI  5  ENABLED

WHITE BALANCE

INITIAL MODE

INITIAL CONDITION

SCSI SETTINGS

→INFO
```

```
INFO

CAMERA
MODEL NAME      9I
VERSION         1.00
LENS            MIDDLE
S/N             2001005

FIELD CALIBRATION SYSTEM
S/N             2001005
```

Item	Explanation
CAMERA	Displays information about the VIVID 9i digitizer.
MODEL NAME	Shows the model name ("VIVID 9i").
VERSION	Displays the internal software's version number.
LENS	Identifies the lens that is currently mounted. TELE: Telephoto lens MIDDLE: Middle lens WIDE: Wide lens
S/N	Shows the serial number.
FIELD CALIBRATION SYSTEM	Shows information about the field calibration system.
S/N	Shows the serial number of the field calibration system.

Adjusting the Laser Power and CCD Gain Manually

With certain objects, correct image data cannot be obtained.

In this case, adjust the laser power and CCD gain as explained below.

Adjustment must be made using the Polygon Editing Tool software. For information about how to proceed, refer to the software's operation manual.

Memo

With the following objects, correct data may not be acquired, the laser power or CCD gain must be adjusted manually.

- Glass etc. which transmit light
- Mirrors etc. which cause mirror reflection
- Electric bulbs etc. which themselves illuminate
- Black or blue cloth which has a low reflectance for red and similar colors



Setting the Scan Mode

The setting of scan mode can be set with Polygon Editing Tool software, and the setting is the top priority. It is not required to set by VIVID 9i.

If you are not making scan settings from your PC's software (for example, if using a customized program), please make the settings at the digitizer itself.

Only settings are explained here.

Note

These settings become effective from the time of next start.

STANDARD 3 HQ ON NF ON
COLOR OFF
W.B. DEFAULT
SCSI 5 ENABLED
WHITE BALANCE
→ INITIAL MODE
INITIAL CONDITION
SCSI SETTINGS
INFO

Item	Explanation
INITIAL MODE	Selects one of the preset scan modes.
DIGITIZE	Selects the scan mode. <ul style="list-style-type: none"> STANDARD: Allowable distance is 600 to 1000 mm. The following initial conditions cannot be changed: NOISE FILTER: ON; HIGH QUALITY: ON EXTENDED: Allowable distance is 500 to 2500 mm. The following initial conditions cannot be changed: NOISE FILTER: ON; HIGH QUALITY: OFF USER: Allowable distance is 500 to 2500 mm. Initial conditions can be changed as desired.
COLOR	Selects the color mode for image capture. <ul style="list-style-type: none"> ON: Full color OFF: No image
INITIAL CONDITION	Makes settings that are more detailed than the initial mode settings. Available settings vary according to the selected initial mode. Initial conditions that cannot be changed (as determined by the DIGITIZE scan mode) are not displayed.
NUMBER OF SCANS	Sets number of scans. Allows for increased dynamic range.
NOISE FILTER	If ON, noise filtering is applied to scan data.
HIGH QUALITY	If ON, unreliable scan data is discarded.
DARK	If ON, dark correction is applied to color data. Use this feature when you want to remove the CCD offset components and get the signal components only. This setting is not shown if INITIAL MODE-COLOR is set to OFF.>
LOG	If ON, log correction is applied to color data. Use this feature when you want to brighten intermediate colors. This setting is not shown if INITIAL MODE-COLOR is set to OFF.

Chapter 4

Appendix



Error Messages

The following error messages appear if incorrect operation is performed or an abnormality occurs with the VIVID 9i. If an error message appears, take the appropriate corrective actions as shown in the table below. If the problem still does not disappear, contact a KONICA MINOLTA SENSING authorized service facility.

Error Message (Alphabetically)	Meaning	Action
AF ERROR LOW CONTRAST PRESS ANY KEY	Auto-focus failed due to low contrast of the object. Press any key.	Set the manual focus.
BACKUP ERROR PRESS ANY KEY	Failed to back up the data. Press any key.	All the settings will be initialized, so set them again.
BACKUP ERROR PRESS ANY KEY AND SCAN FIELD CALIBRATION SYSTEM	Failed to back up field calibration values. Press any key and scan field calibration system.	Field calibration values have been reinitialized. Please try field calibration again.
CAUTION LASER SCANNER IS OUT OF ORDER PLEASE TURN OFF	The laser beam is not emitted properly. Turn off the power immediately.	Highly dangerous! Turn off the power immediately and contact a KONICA MINOLTA SENSING authorized service facility.
CHANGE LENS S/N ***** PRESS ANY KEY AND SCAN FIELD CALIBRATION SYSTEM	The lens is now being replaced. Press any key and scan field calibration system.	Attach the lens hood properly. Check the serial No. of the lens, and replace the lens properly.
LIGHT IMPROPER	Inadequacy amount of light	Illuminate the object brighter and scan it.
SAME FILE NAME	A file of the same file name already exists.	Specify another file name.
SYSTEM ERROR PLEASE TURN OFF	A system error has occurred. Turn OFF the power.	Turn OFF the power, then turn it ON again. If the problem still does not disappear, contact a KONICA MINOLTA SENSING-authorized service facility.
TERMINATE ERROR PRESS ANY KEY SET TERMINATE ENABLE	SCSI terminator error has occurred. Press any key and set the terminator to "ENABLE".	Set the terminator to "ENABLE".
WB ERROR LIGHT IMPROPER PRESS ANY KEY	Failed to adjust white balance. Press any key.	Adjust white balance in a bright place. (White balance in effect before occurrence of this error has not been updated.)

Explanation of Measuring Principle

Measuring Principle

The VIVID 9i uses the light-stripe method to emit a horizontal stripe light through a cylindrical lens to the object. The reflected light from the object is received by the CCD, and then converted by triangulation into distance information.

This process is repeated by scanning the stripe light vertically on the object surface using a Galvano mirror, to obtain a 3D image data of the object.

In addition, a color image of the object is also obtained by scanning the CCD through a RGB filter while the stripe light is not emitted. (A band pass filter is used when stripe light is emitted.)

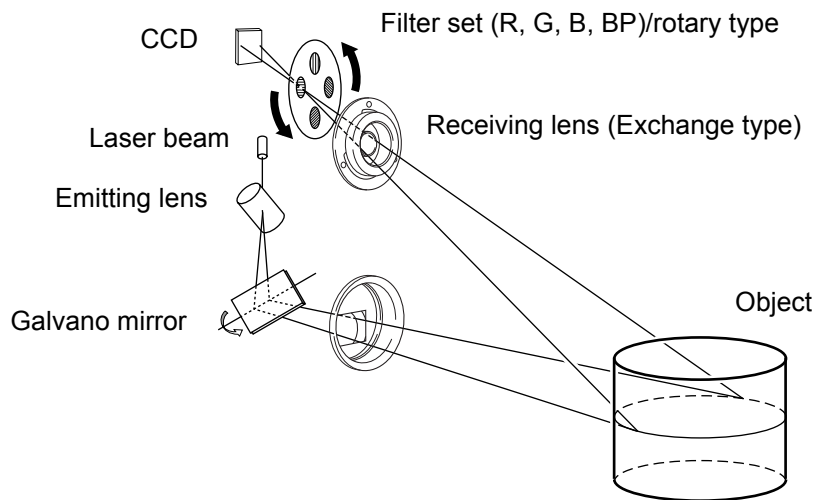

High-Speed Image Processing Circuit

The stripe light is scanned on the CCD image plane at one horizontal line per frame, and the CCD is driven so that the block readout start position is shifted one line per frame.

Approximately 600 frames are acquired.

- CCD drive rate: 12.5MHz
- Block readout: 125 lines
- Data acquisition speed: 2.5 sec.

The output signal from the CCD is then converted into a digital signal, which is then subjected to digital signal processing. The signal processed data is finally saved in the frame memory.

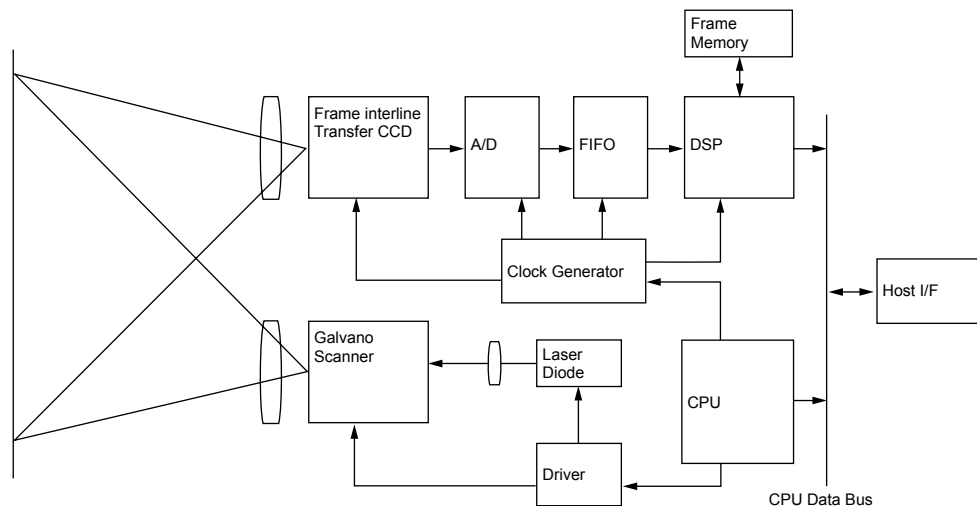

Time center of gravity and Space center of gravity

Time center of gravity is the center of gravity of the variation in the LD light passing CCD's one picture element over a period of time.

Space center of gravity is the center of gravity of the spatial variation in the LD light on the CCD at a certain time.

With this instrument, 3D images are obtained by calculating the Time center of gravity of each picture element of CCD. Intersection of the viewing angle of each picture element of the CCD and passing angle (time) of the stripe light is calculated.

Compared to the Space center of gravity, use of Time center of gravity can reduce influences of sensitivity variation of CCD's picture elements and variation of brightness of the object.

Dimension Diagram

(Unit: mm)

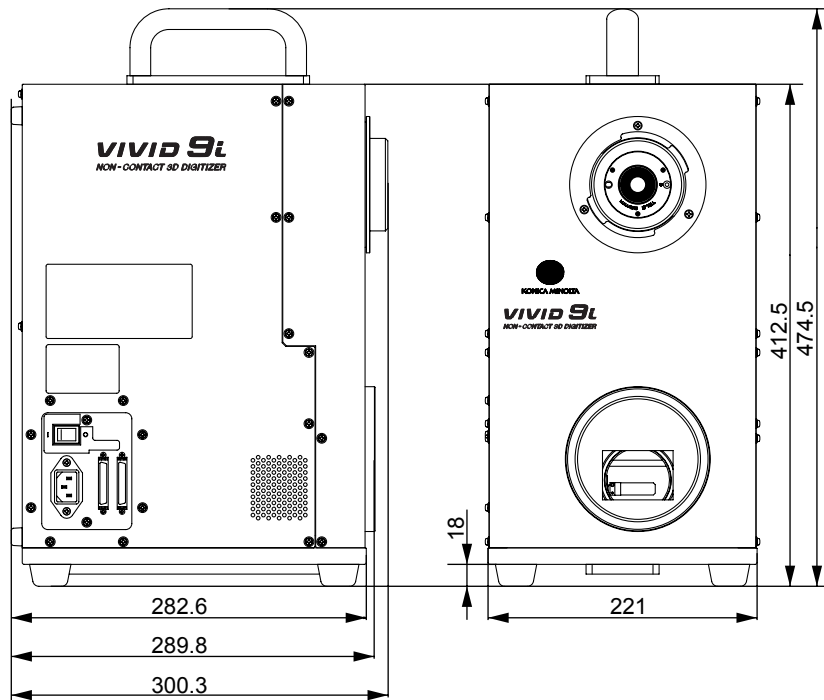

Specifications

Model Name	Non-contact 3D digitizer VIVID 9i/VI-9i
Measurement Method	Triangulation, light block method
AF	Image surface AF (contrast method), Active AF
Light-Receiving lens (Inter-changeable)	TELE : Focal distance f=25 mm MIDDLE: Focal distance f=14 mm WIDE : Focal distance f=8 mm
Object Distance Range	0.6 to 2.5 m
Scan Range	0.6 to 1.0 m (In Standard mode), 0.5 to 2.5 m (In Extended mode)
Laser Scan Method	Galvano mirror
Laser Class	Class 2 (IEC60825-1), Class 1 (FDA), Max. 30 mW, 690 nm
X Direction Input Range (In Extended mode)	93 to 463 mm (TELE), 165 to 823 mm (MIDDLE), 299 to 1495 mm (WIDE)
Y Direction Input Range (In Extended mode)	69 to 347 mm (TELE), 124 to 618 mm (MIDDLE), 224 to 1121 mm (WIDE)
Z Direction Input Range (In Extended mode)	26 to 680 mm (TELE), 42 to 1100 mm (MIDDLE), 66 to 1750 mm (WIDE mode)
Accuracy	TELE XYZ: ± 0.05 mm/ ± 0.10 mm MIDDLE XYZ: ± 0.10 mm/ ± 0.20 mm WIDE XYZ: ± 0.20 mm/ ± 0.40 mm (Conditions: Distance 0.6 m/ 1.0 m, KONICA MINOLTA SENSING's standard 3D chart, KONICA MINOLTA SENSING's processing software, temperature 20°C, relative humidity 65% or less)
Precision (Z, σ)	TELE 0.008 mm/ ± 0.024 mm MIDDLE 0.016 mm/ ± 0.048 mm WIDE 0.032 mm/ ± 0.096 mm (Conditions: Distance 0.6 m/ 1.0 m, KONICA MINOLTA SENSING's standard 2D chart, KONICA MINOLTA SENSING's processing software, temperature 20°C, relative humidity 65% or less)
Input Time (per scan)	2.5 sec.
Transfer Time to Host Computer	Approx. 1.5 sec.
Ambient Lighting Condition	Office environment, 500 lx or less
Imaging Element	3D data : 1/3-inch frame transfer CCD (340,000 pixels) Color data : Common with 3D data (color separation by rotary filter)
Number of Output Pixels	3D data : 640 \times 480 (640 \times 460 in the HIGH QUALITY mode) Color data : 640 \times 480
Output Format	3D data: Konica Minolta format, & (STL, DXF, OBJ, ASCII points, VRML) (Converted to 3D data by the Polygon Editing Tool Software / standard accessory) Color data : RGB 24-bit raster scan data
Data File Size	Total 3D and color data capacity: 3.6 MB per data
Viewfinder	5.7-inch LCD (320 \times 240 picture elements) * There may be rare cases in which the point that is normally lit or unlit may break up (dot break up); however, this will not have any influence on the scanning data.
Output Interface	SCSI II (DMA synchronous transfer)
Power	Commercial AC power, 100-240 V \sim (50-60Hz), rated current 0.6 A (at 100 V AC)
Dimensions	221 (W) \times 412 (H) \times 282 (D) mm
Mass	Approx. 15 kg (with lens attached)
Temperature / Humidity	Operating environment: 10 to 40°C (50°F to 104°F); 65% RH or less/no condensation; Installation category: II; Pollution degree: 2; Maximum altitude: 2000 m
Storage Temperature Range	0 to 40°C, 85% or less (at 35°C)/no condensation

The above specifications are subject to change without prior notice.



KONICA MINOLTA

Free Manuals Download Website

<http://myh66.com>

<http://usermanuals.us>

<http://www.somanuals.com>

<http://www.4manuals.cc>

<http://www.manual-lib.com>

<http://www.404manual.com>

<http://www.luxmanual.com>

<http://aubethermostatmanual.com>

Golf course search by state

<http://golfingnear.com>

Email search by domain

<http://emailbydomain.com>

Auto manuals search

<http://auto.somanuals.com>

TV manuals search

<http://tv.somanuals.com>