

KORG[®]

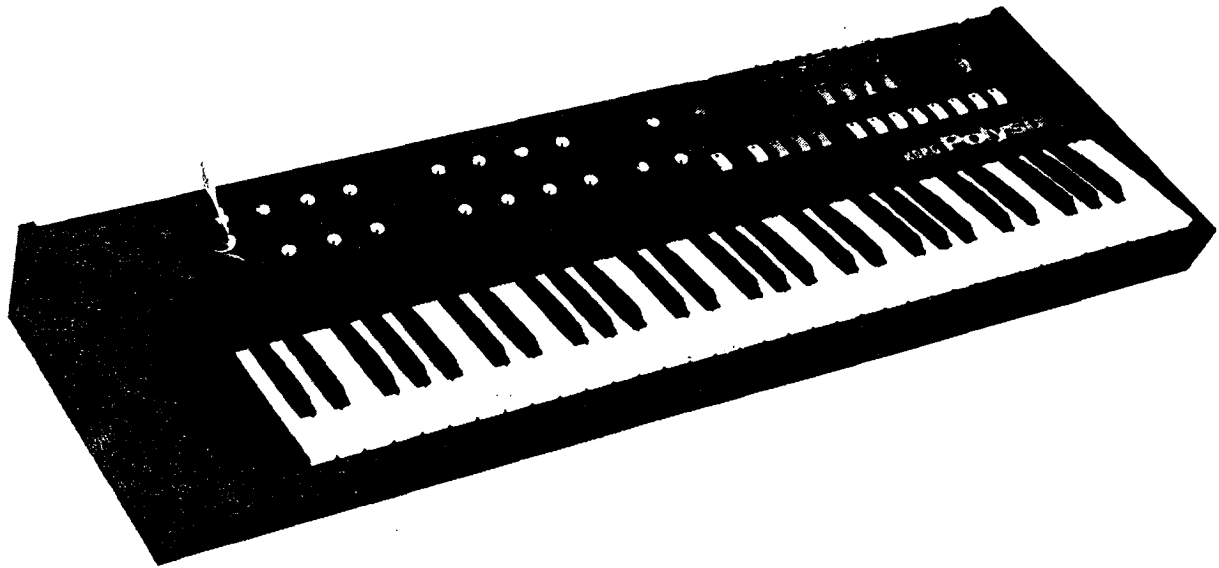

PROGRAMMABLE 6VOC SYNTHESIZER SERVICE MANUAL

POLYSIX

CONTENTS

1. SPECIFICATIONS	1
2. STRUCTURAL DIAGRAM	2
3. BLOCK DIAGRAM	3
4. CIRCUIT DIAGRAM	4
5. PC BOARD	5
6. CONNECTOR FUNCTION	17
7. SEMI-FIXED RESISTORS DIAGRAM ...	18
8. ADJUSTMENT PROCEDURE	19
9. PARTS LIST	24

KEIO ELECTRONIC LABORATORY CORPORATION
TOKYO/JAPAN

1. SPECIFICATIONS

KEYBOARD	● 61 keys (C ~ C)
VOICES: 6	
(Program and edit functions are possible for items marked *)	
VCO*	● Octave Selector (16', 8', 4')
	● Waveform (\wedge , PW, PWM)
	● Pulse Width/PWM Sensitivity Adjustment
	● PWM Speed
SUBOSCILLATOR*	● Off
	● 1 oct Down
	● 2 oct Down
VCF*	● Cutoff Frequency Adjustment
	● Resonance Adjustment
	● Envelope Generator Modulation
	● Sensitivity Adjustment
	● Keyboard Tracking Adjustment (0 ~ 150%)
ENVELOPE GENERATOR*	● Attack Time
	● Decay Time
	● Sustain Level
	● Release Time
VCA*	● Mode Switch (EG, \square)
	● Attenuator (-10dB ~ +10dB, 11 Steps)
MODULATION GENERATOR*	● Frequency
	● Delay Time
	● Level
	● Modulation (VCO, VCF, VCA)
EFFECT*	● Mode (Off, Chorus, Phase, Ensemble)
	● Speed/Sensitivity Adjustment
KEY ASSIGN MODE	● Poly
	● Unison
	● Chord Memory
	● Hold
ARPEGGIATOR	● Speed
	● (0.4Hz ~ 40Hz)
	● Range (Full, 2 oct, 1 oct)
	● Mode (Up, Down Up/Down)
	● Latch (On/Off)
	● Arpeggio (On/Off)
TUNE	● ± 50 Cents
BEND	● Sensitivity Adjustment (MAX ± 1300 Cents)
OUTPUT	● Level Selector (Off, Low, High)
	● Volume
PROGRAMMER	● Bank (A, B, C, D)
	● Program (1 ~ 8)
	● Write (Enable, Disable)
TAPE INTERFACE	● Switch (Enable, Disable)
	● To Tape
	● From Tape
	● Verify
	● Error/Cancel
	● Tape Indicator x 2 (Found, Loading)
CONTROL WHEEL x 2	● Bend
	● MG
INPUT JACKS	● From Tape (With High/Low Switch)
	● Chord Memory (\square)
	● Arpeggio Trigger In (\square)
	● VCF fcM In (-5V ~ +5V)
OUTPUT JACKS	● To Tape (With High/Low Switch)
	● Headphone
	● Output
DIMENSIONS	● 980 (W) x 373 (D) x 132 (W) mm
WEIGHT	● 11.5 kg
ACCESSORIES INCLUDED	● Connection Cord
	● Plug Adaptor (Phone-To-Mini)
	● Memory Cassette
POWER CONSUMPTION	● Voltage (Local Voltage 50/60 Hz)
	● Wattage (25 W)

2. STRUCTURAL DIAGRAM

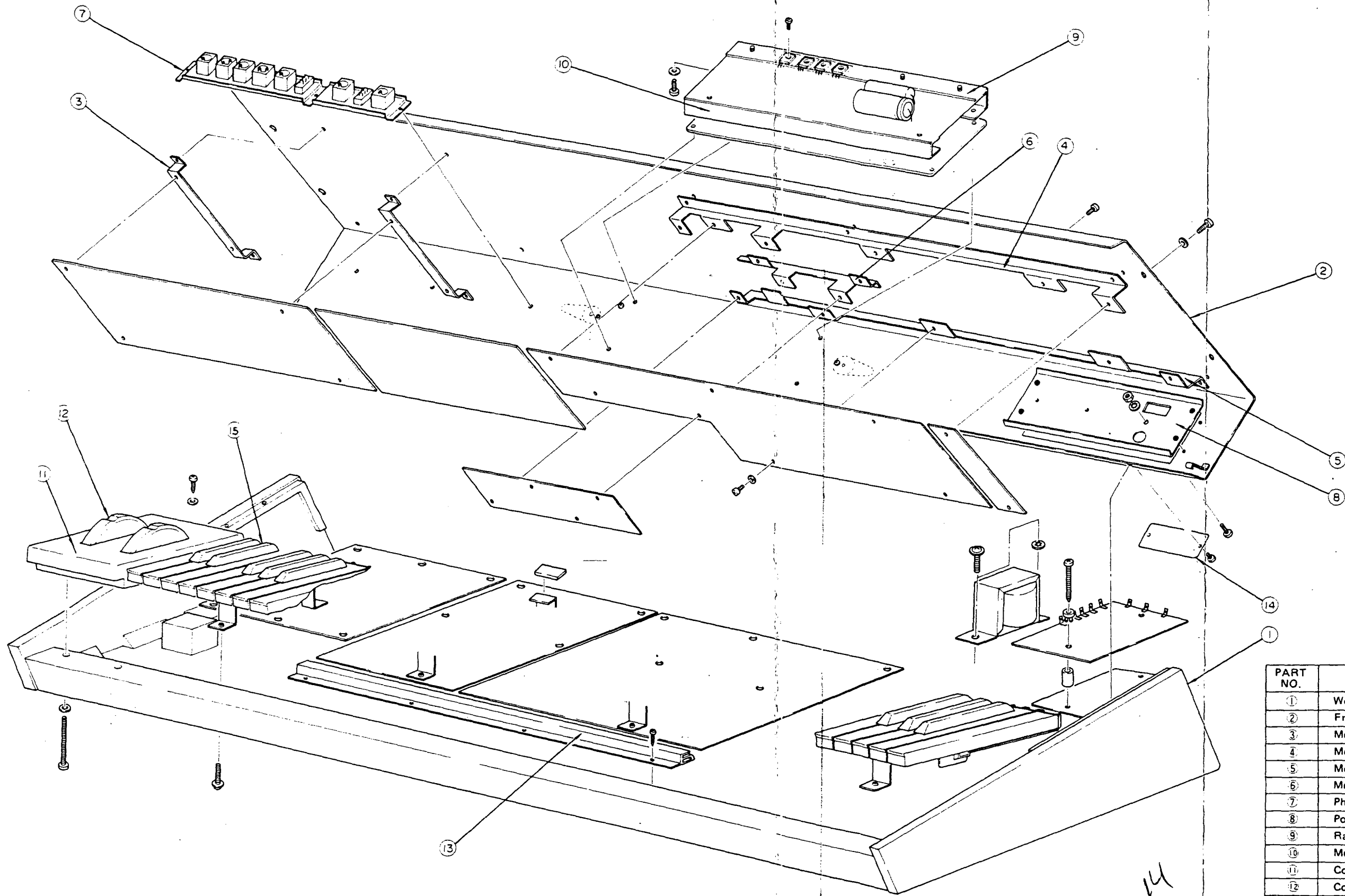

18192022

PART NO.	PART NAME	REMARKS
①	Wooden case	KOC-D10005
②	Front panel	KOC-C20111
③	Metal fitting of KLM-369	KOC-C40399
④	Metal fitting of KLM-371	KOC-C30179 2
⑤	Metal fitting of KLM-371	KOC-C30179 1
⑥	Metal fitting of KLM-371	KOC-C30179
⑦	Phone jack plate	KOC-C30178
⑧	Power plate	KOC-C40397
⑨	Radiation board	KOC-C40406
⑩	Metal fitting of KLM-376	KOC-C40405
⑪	Control panel	KOC-E20028
⑫	Control wheel	KOC-E40091
⑬	PCB rail	
⑭	Model number plate	KOC-C40144
⑮	Key board	ESK-701 (61 keys)

14

4589

3. BLOCK DIAGRAM

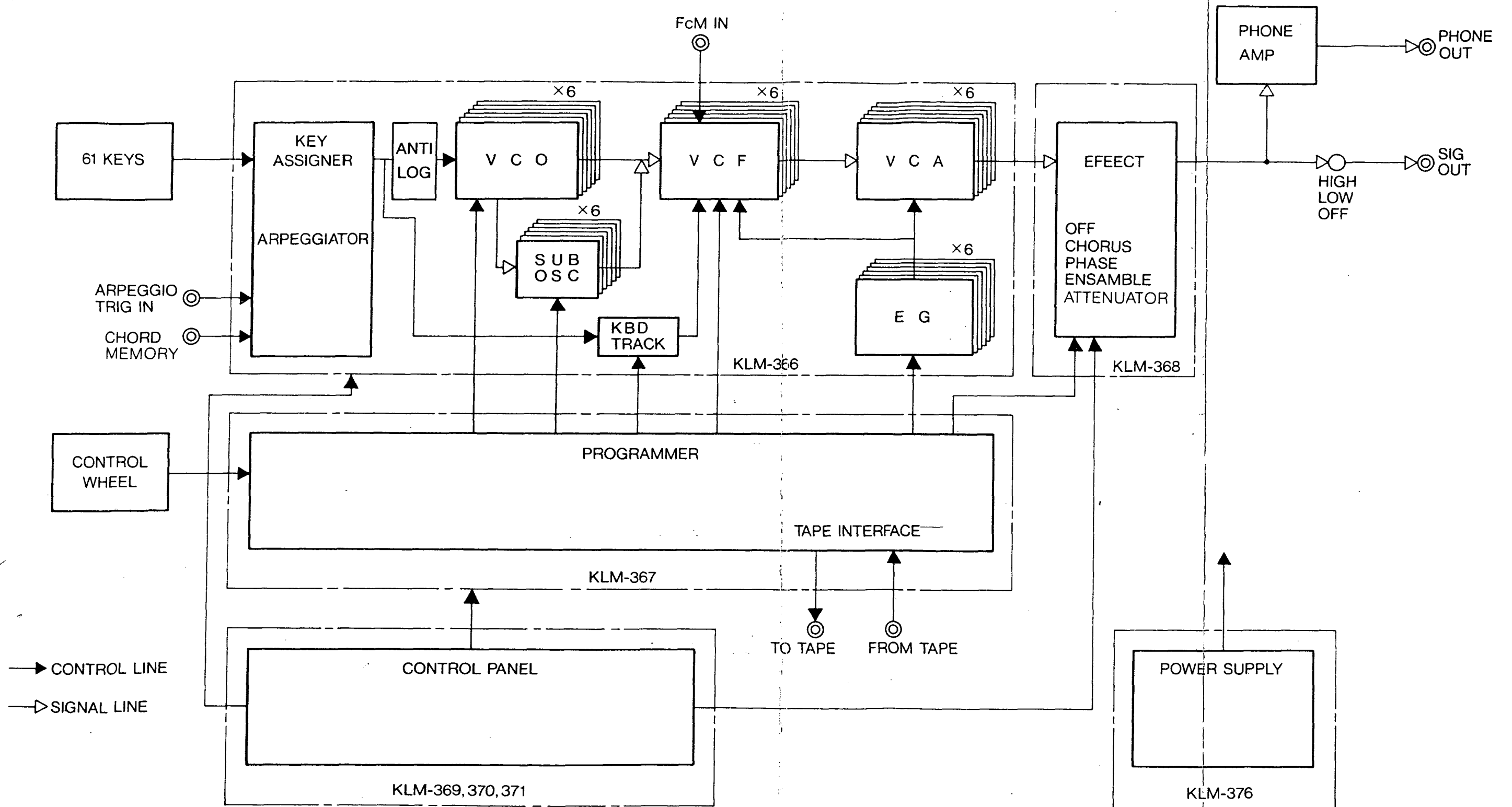

4. CIRCUIT DIAGRAM

KLM-366 KEY ASSIGNER (OLD PRODUCTION)

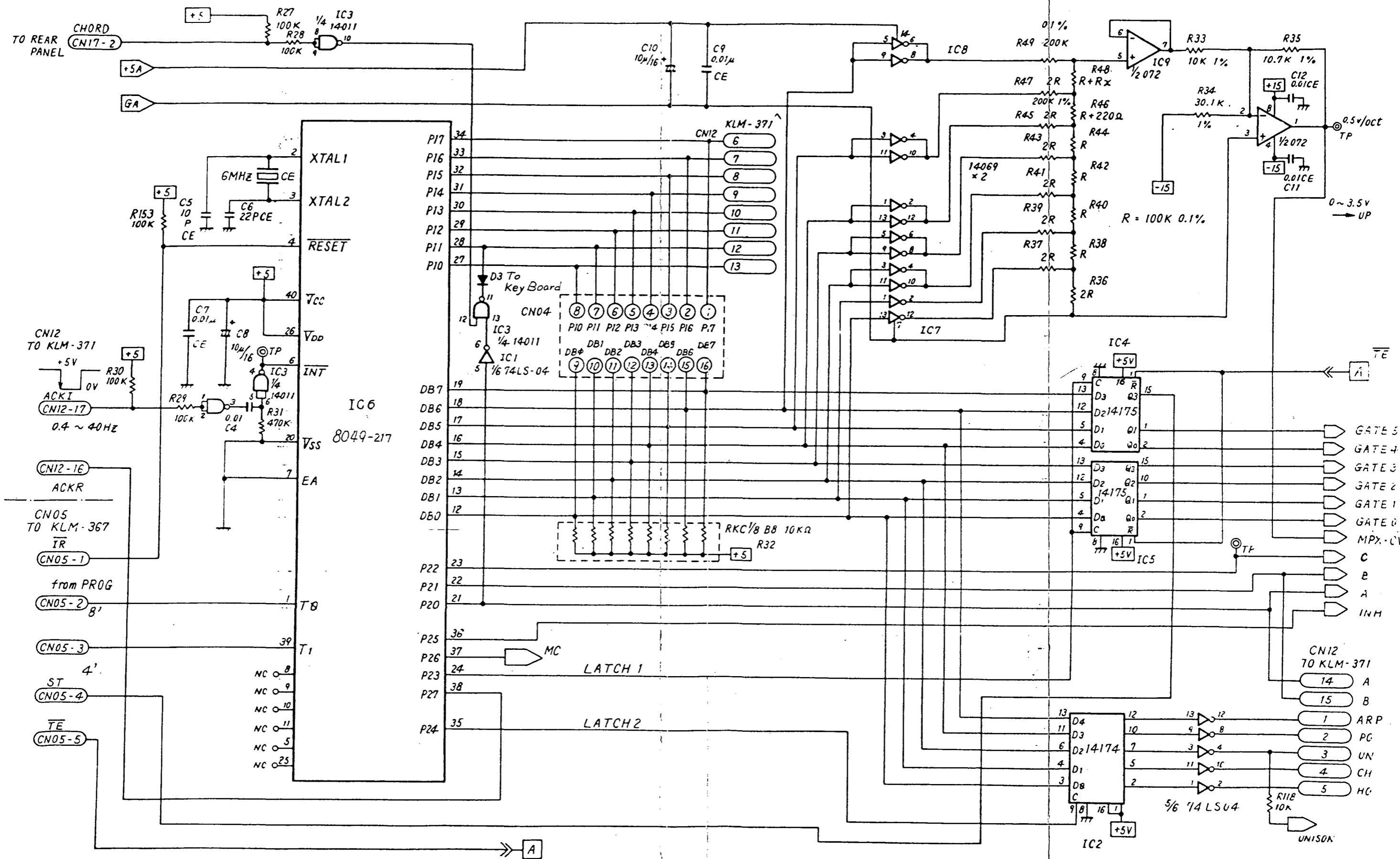

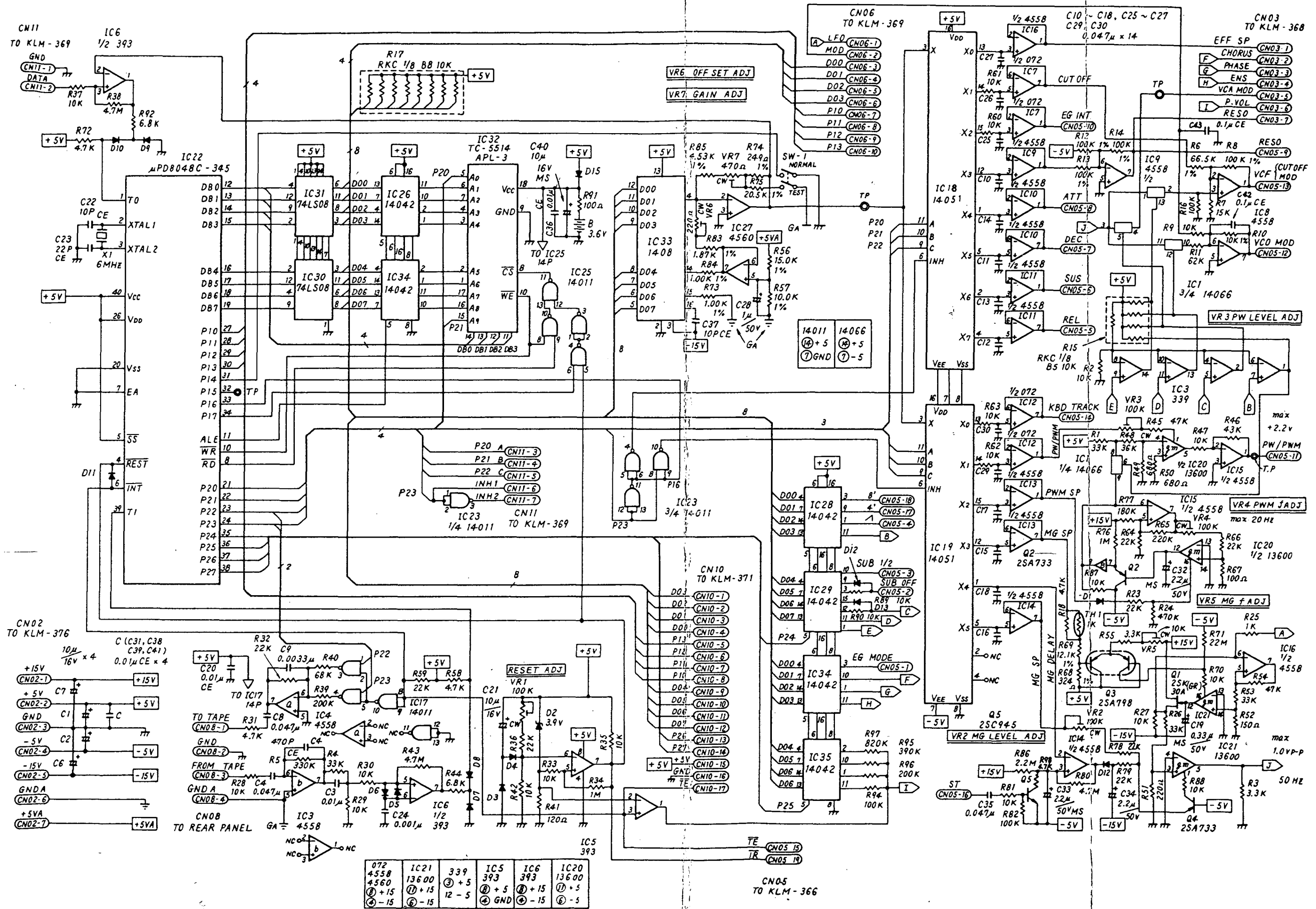

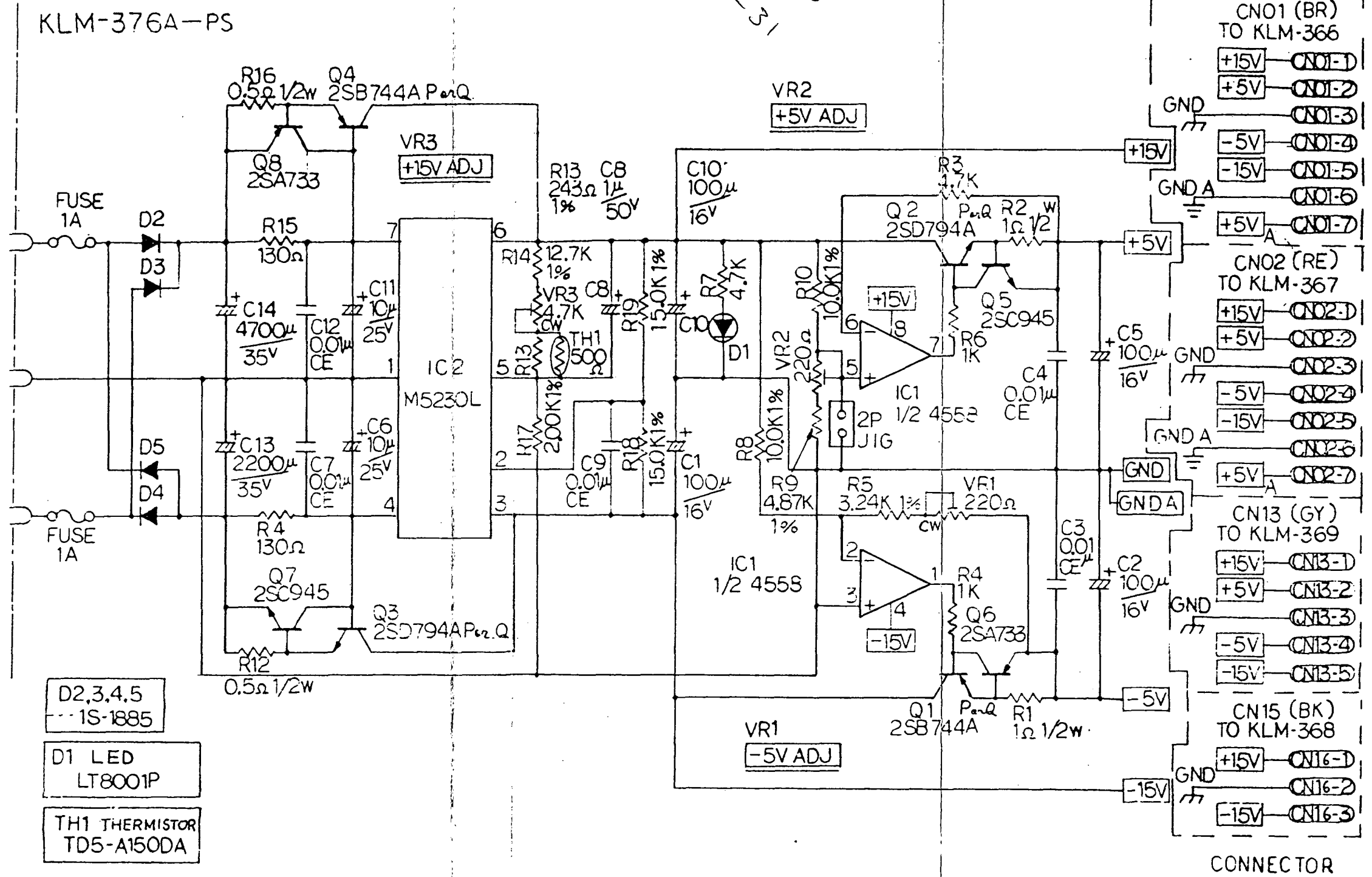
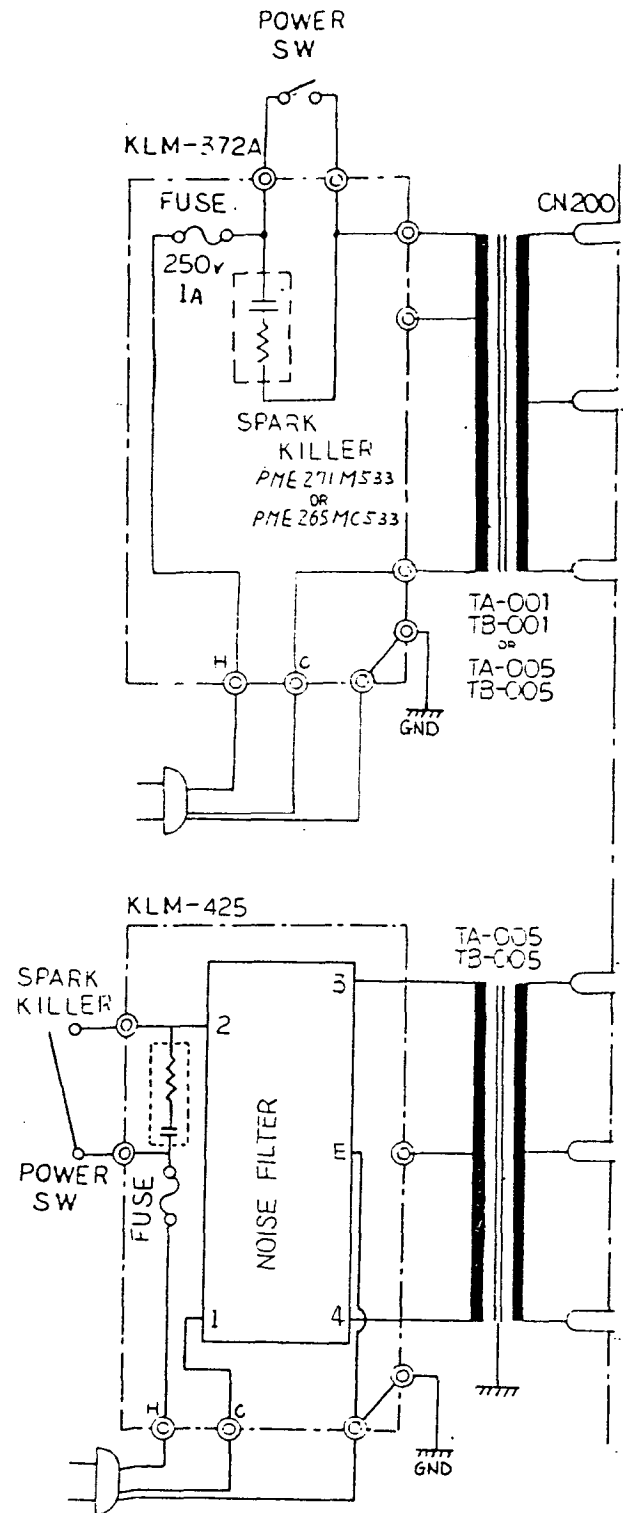

- D2,3,4,5 1S-1885
- D1 LED LT8001P
- TH1 THERMISTOR TD5-A150DA

VOLTAGE	TA		TB	
	100V	120V	220V	240V
3	BROWN	ORANGE	YELLOW	GREEN
4	WHITE		WHITE	
NC	ORANGE	BROWN	GREEN	YELLOW

CONNECTOR

5. PC BOARD

KLM-366 (NEW PRODUCTION)

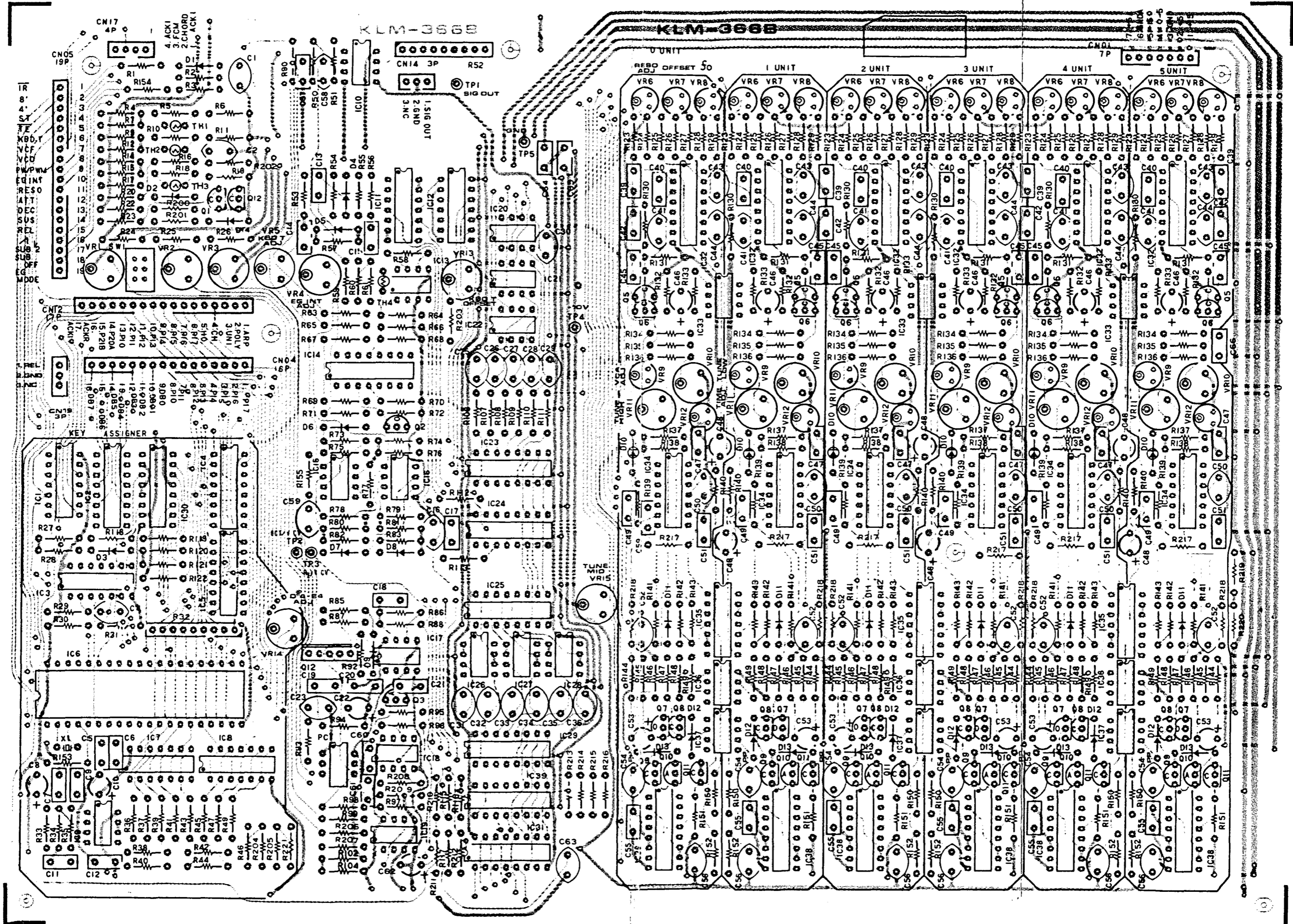

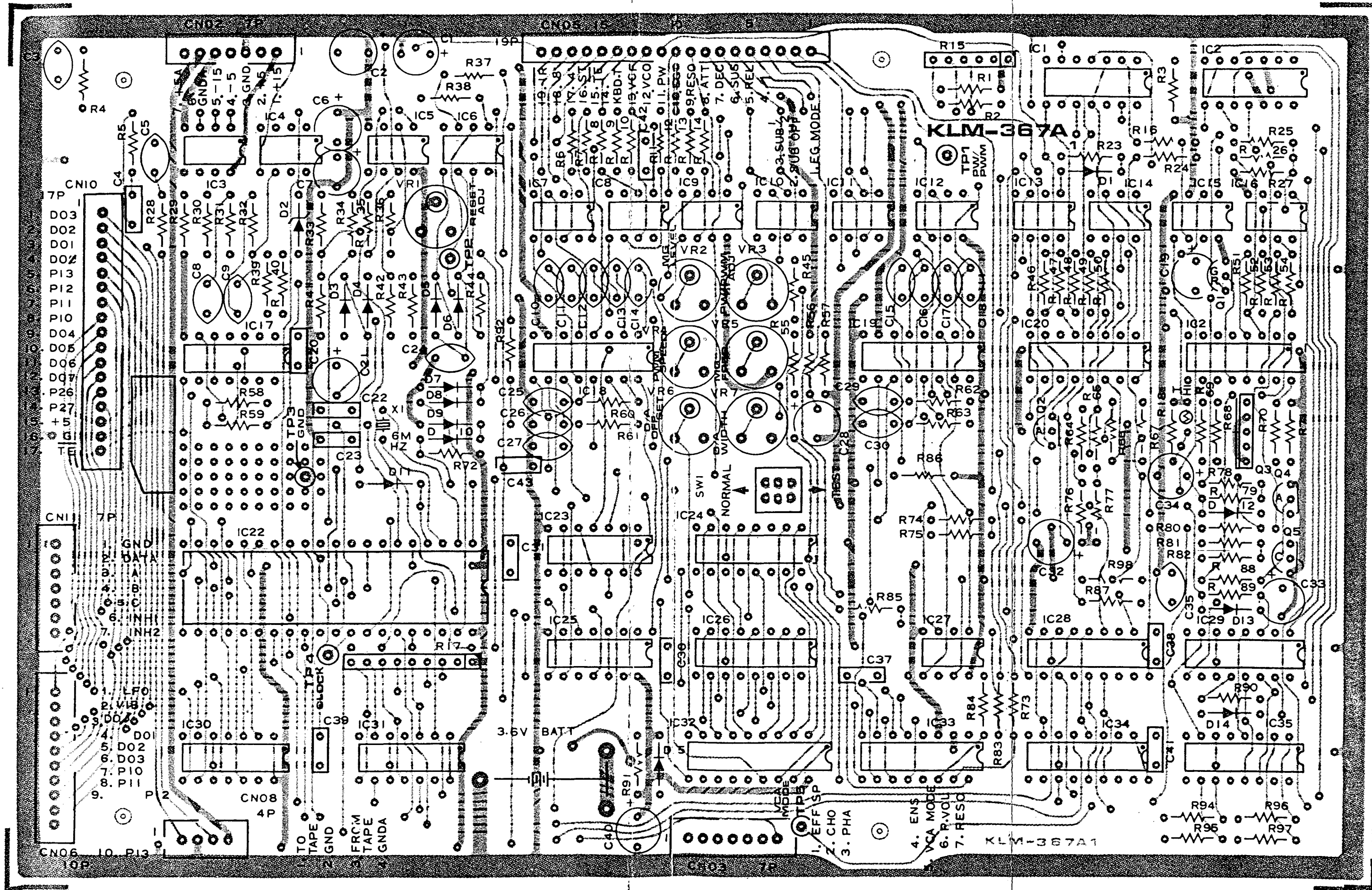

KLM-368 EFFECT

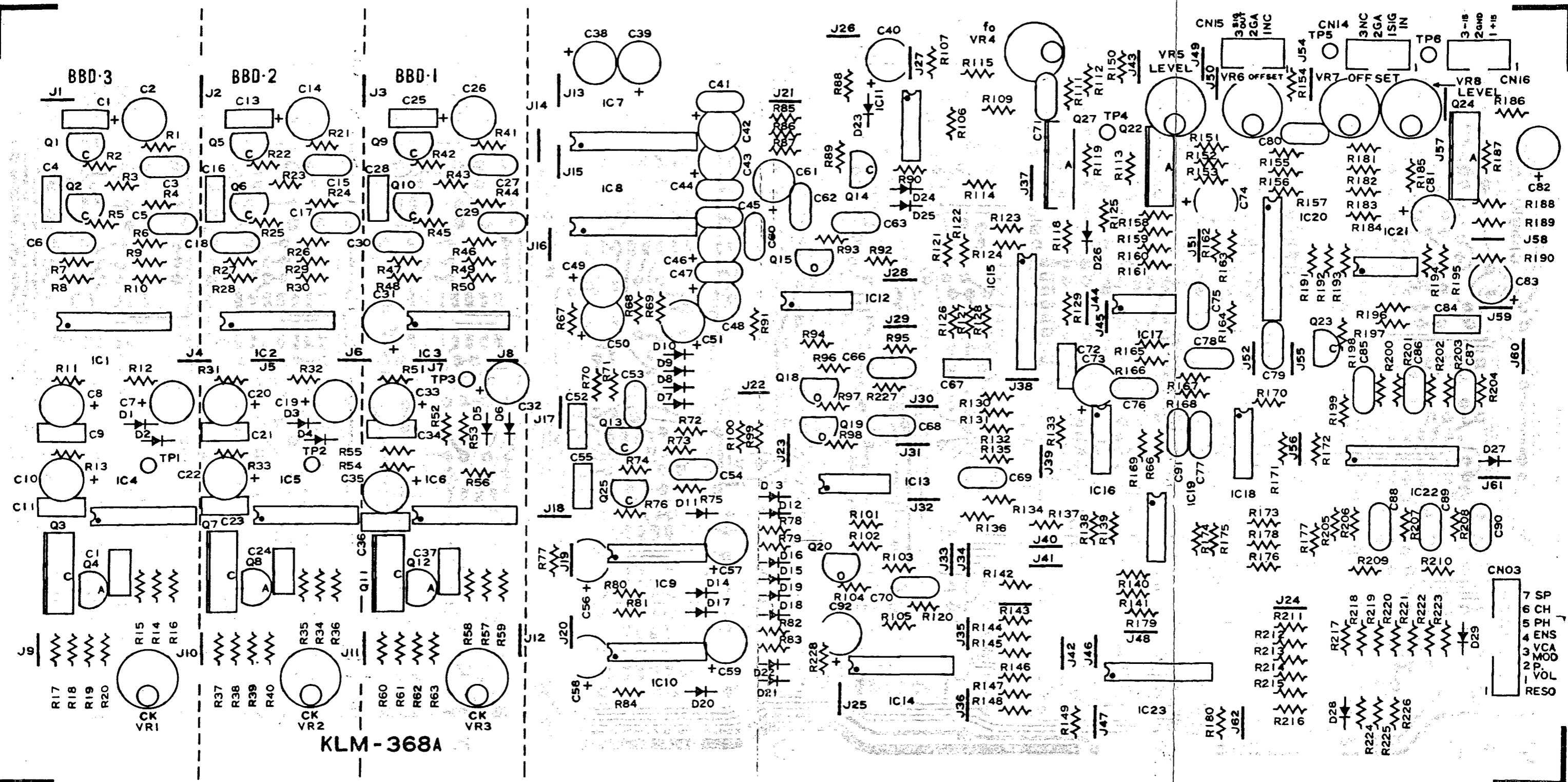

KLM-368A

- 7 SP
- 6 CH
- 5 PH
- 4 ENS
- 3 VCA
- 2 MOD
- 1 VOL
- RESO

KLM-369

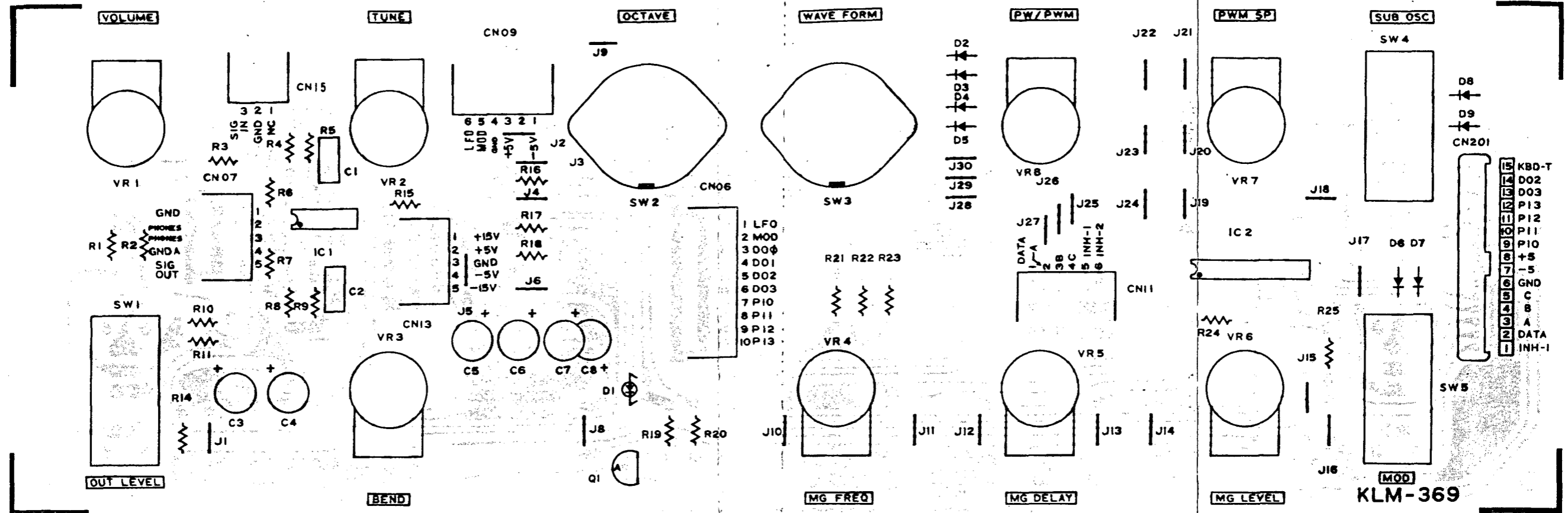

KLM-370

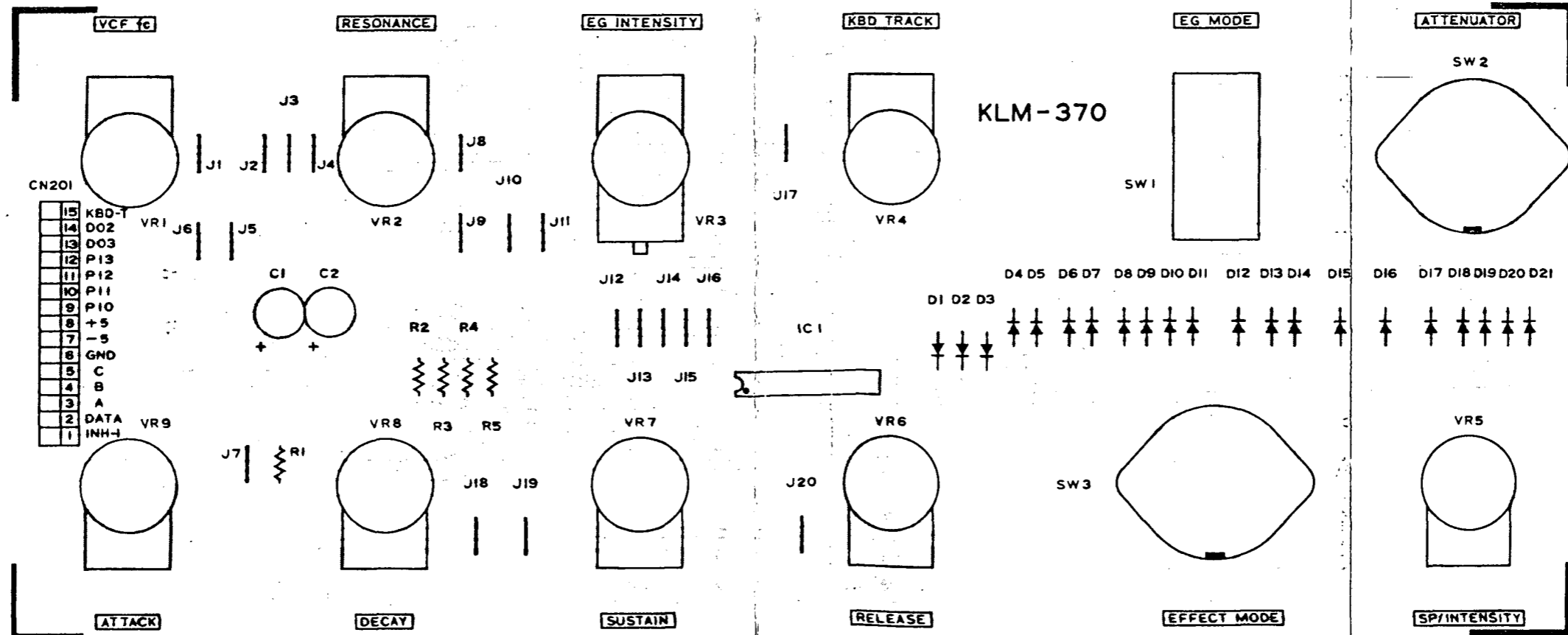

KLM-371

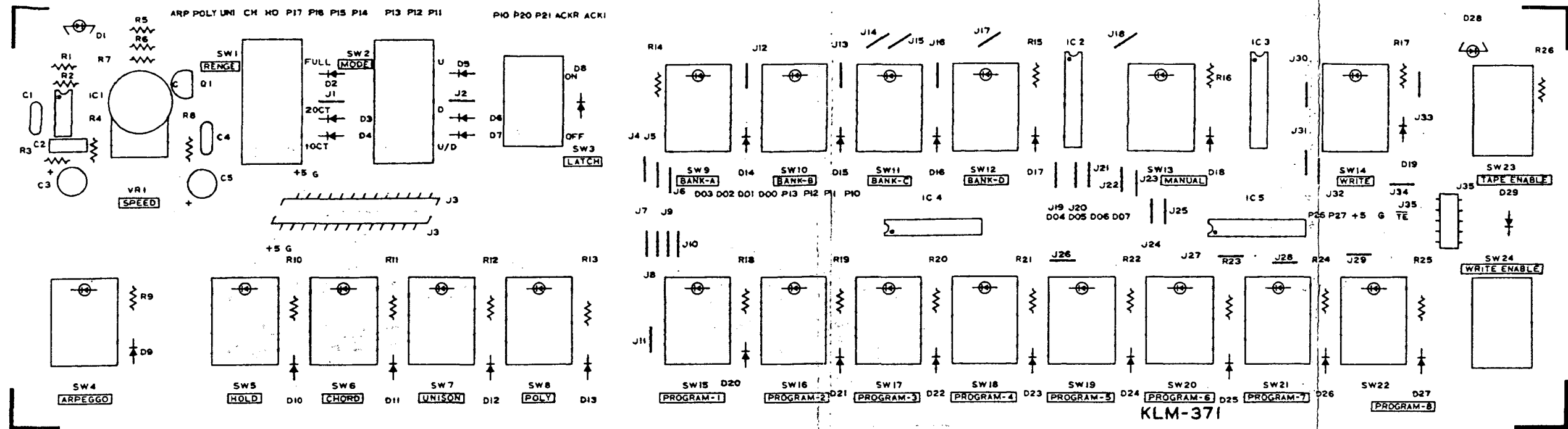

KLM-376

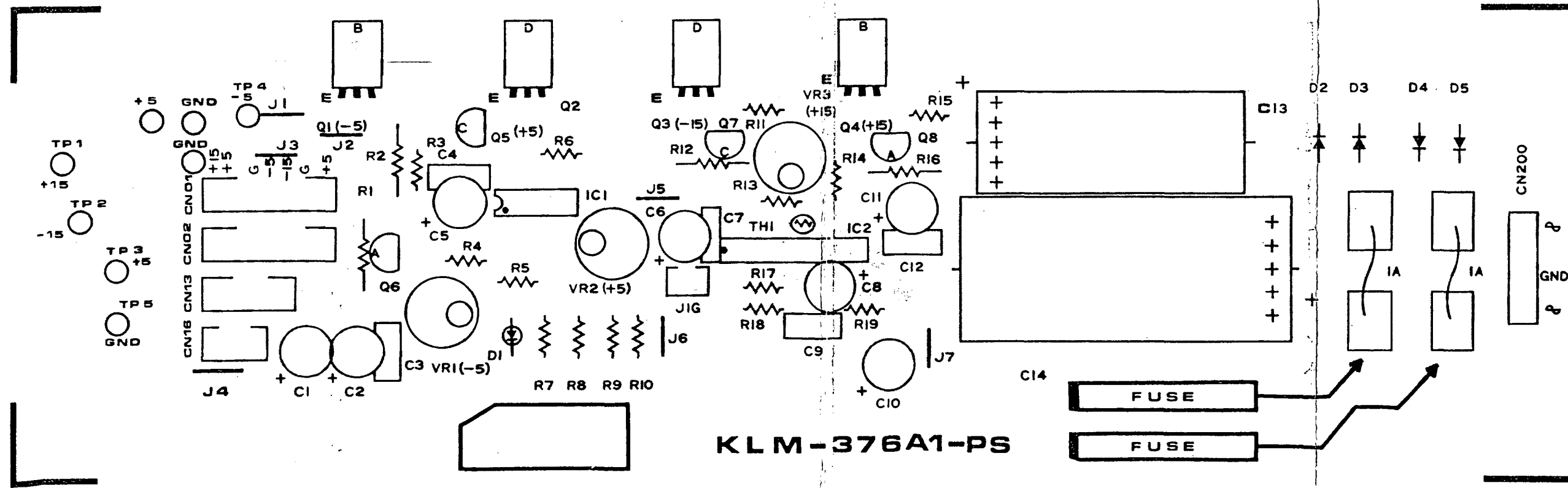

6. CONNECTOR FUNCTION

P.C.B.	CONNECTOR	FUNCTION	P.C.B.	TO CONNECTOR	COLOR	P.C.B.	CONNECTOR	FUNCTION	P.C.B.	TO CONNECTOR	COLOR	P.C.B.	CONNECTOR	FUNCTION	P.C.B.	TO CONNECTOR	COLOR	P.C.B.	CONNECTOR	FUNCTION	P.C.B.	TO CONNECTOR	COLOR
KLM-366	01- 1	+15	KLM-376	01- 1	BR																		
	2	+5		2			10	EG INT		10		KLM-369	11- 4	C		5		KLM-371	J35 1	DO7	KLM-371	J35 1	
	3	GND		3			11	PW/PWM		9			5	INH1		6			2	P12		2	
	4	-5		4			12	VCO MOD/CUTOFF		8			6	INH2		7			3	+5		3	
	5	-15		5			13	VCF MOD		7		KLM-369	13- 1	+15	KLM-376	13- 1	GY		4	GND		4	
	6	GND A		6			14	KBD TRACK	KLM-366	6	GR		2	+5		2			5	TE		5	
	7	+5A		7			15	TE		5			3	GND		3		KLM-376	01- 1	+15	KLM-366	01- 1	BR
KLM-366	04- 1	P17	KEY-BOARD		YE		16	ST		4			4	-5		4			2	+5		2	
	2	P16					17	4'		3		KLM-369	13- 5	-15	KLM-376	13- 5	GY		3	GND		3	
	3	P15					18	8'		2		KLM-369	15- 1	NC	KLM-368	15- 3	BK		4	-5		4	
	4	P14				KLM-367	06- 1	MOD	KLM-369	06- 1	BL		2	GND A		2		KLM-376	01- 5	-15	KLM-366	01- 5	BR
	5	P13					2	LFO		2		KLM-369	201- 1	SIG IN		1			6	GND A		6	
	6	P12					3	LFO		3			2	INH-1	KLM-370	201- 1			7	+5		7	
	7	P11					4	DO1		4			2	DATA		2		KLM-376	02- 1	+15	KLM-367	02- 1	RE
	8	P10					5	DO2		5			3	A		3			2	+5		2	
	9	DB0					6	DO3		6			4	B		4			3	GND		3	
	10	DB1					7	P10		7			5	C		5			4	-5		4	
	11	DB2					8	P11		8			6	GND		6			5	-15		5	
	12	DB3					9	P12		9			7	-5		7			6	GND A		6	
	13	DB4					10	P13		10			8	+5		8			7	+5		7	
	14	DB5				KLM-367	08- 1	TO TAPE	REAR PANEL		BR		9	P10		9		KLM-376	13- 1	+15	KLM-369	13- 1	GY
	15	DB6					2	GND			RE		10	P11		10			2	+5		2	
	16	DB7					3	FROM TAPE			OR		11	P12		11			3	GND		3	
KLM-366	05- 1	IR	KLM-367	05- 19	GR		4	GND A					12	P13		12			4	-5		4	
	2	8'		18		KLM-367	10- 1	DO3	KLM-371	10- 1	BR		13	DO3		13			5	-15		5	
	3	4'		17			2	DO2		2	RE		14	DO2		14		KLM-376	16- 1	+15	KLM-368	16- 1	BK
	4	ST		16			3	DO1		3	OR		15	KBD-TRACK		15			2	GND		2	
	5	TE		15			4	DO0		4	YE	KLM-370	201- 1	INH-1	KLM-369	201- 1			3	-15		3	
	6	KBD TRACK		14			5	P13		5	GR		2	DATA		2							
	7	VCF MOD/CUTOFF		13			6	P12		6	BL		3	A		3							
	8	VCO MOD		12			7	P11		7	PU		4	B		4							
	9	PW/PWM		11			8	P10		8	GY		5	C		5							
	10	EG INT		10			9	DO4		9	WH		6	GND		6							
	11	RESO		9			10	DO5		10	BK		7	-5		7							
	12	ATTACK		8			11	DO6		11	BR		8	+5		8							
	13	DECAY		7			12	DO7		12	RE		9	P10		9							
	14	SUSTAIN		6			13	P26		13	OR		10	P11		10							
	15	RELEASE		5			14	P27		14	YE		11	P12		11							
	16	RELEASE		4			15	+5		15	GR		12	P13		12							
	17	SUB 1/2		3			16	GND		16	BL		13	DO3		13							
	18	SUB OFF		2			17	TE		17	PU		14	DO2		14							
	19	EG MODE		1		KLM-367	11- 1	GND	KLM-369	11- 1	PU		15	KBD TRACK		15							
KLM-366	12- 1	ARPE	KLM-371	12- 1	BR		2	DATA		2	PU	KLM-371	10- 1	DO3	KLM-367	10- 1	BR						
	2	POLY		2	RE		3	A		3			2	DO2		2	RE						
	3	UNISON		3	OR		4	B		4			3	DO1		3	OR						
	4	CHORD		4	YE		5	C		5			4	DO0		4	OR						
	5	HOLD		5	GR		6	INH1		6			5	P13		5	YE						
	6	P17		6	BL		7	INH2		7			6	P12		6	GR						
	7	P16		7	PU	KLM-368	03- 1	RESO	KLM-367	03- 7	OR		7	P11		7	BL						
	8	P15		8	GY		2	P. VOL		6			8	P10		8	PU						
	9	P14		9	WH		3	VCA MOD		5			9	DO4		9	GY						
	10	P13		10	BK		4	ENS		4			10	DO5		10	WH						
	11	P12		11	BR		5	PHA		3			11	DO6		11	BK						
	12	P11		12	RE		6	CHO		2			12	DO7		12	BR						
	13	P10		13	OR		7	EFF SP/INT		1			13	P26		13	RE						
	14	P20		14	YE	KLM-368	14- 1	SIG IN	KLM-366	14- 1	WH		14	P27		14	OR						
	15	P21		15	GR		2	GND A		2			15	+5		15	YE						
	16	ACKR		16	BL		3	NC		3			16	GND		16	GR						
	17	ACKI		17	PU	KLM-368	15- 1	NC	KLM-369	15- 3	BK		17	TE		17	BL						
KLM-366	14- 1	SIG OUT	KLM-368	14- 1	WH	KLM-368	15- 2	GND A		2		KLM-371	12- 1	ARPE	KLM-366	12- 1	BR						
	2	GND A		2			3	SIG OUT		1			2	POLY		2	RE						
	3	NC		3		KLM-368	16- 1	+15	KLM-376	16- 1	P1		3	UNISON		3	OR						
KLM-366	17- 1	ACKI (IN)	REAR PANEL		BR		2	GND		2			4	CHORD		4	YE						
	2	CHORD			RE		3	-15		3			5	HOLD		5	GR						
	3	Fc MOD IN			OR	KLM-369	06- 1	MOD	KLM-367	06- 1	BL		6	P17		6	BL						
	4	ACKI (OUT)			YE		2	LFO		2			7	P16		7	PU						
KLM-367	02- 1	+15	KLM-376	02- 1	RE		3	DO0		3			8	P15		8	GY						
	2	+5		2			4	DO1		4			9	P14		9	WH						
	3	GND		3			5	DO2		5			10	P13		10	BK						
	4	-5		4			6	DO3		6			11	P12		11	BR						
	5	+15		5			7	P10		7			12	P11		12	RE						
	6	GND A		6			8	P11		8			13	P10		13	OR						
	7	+5A		7			9	P12		9			14	P20		14	YE						
KLM-367	03- 1	EFF-SP/INT	KLM-368	03- 7	OR		10	P13		10			15	P21		15	GR						
	2	CHO		6		KLM-369	07- 1	GND	REAR PANEL		BR		16	ACKR		16	BL					</	

7. SEMI-FIXED RESISTORS DIAGRAM

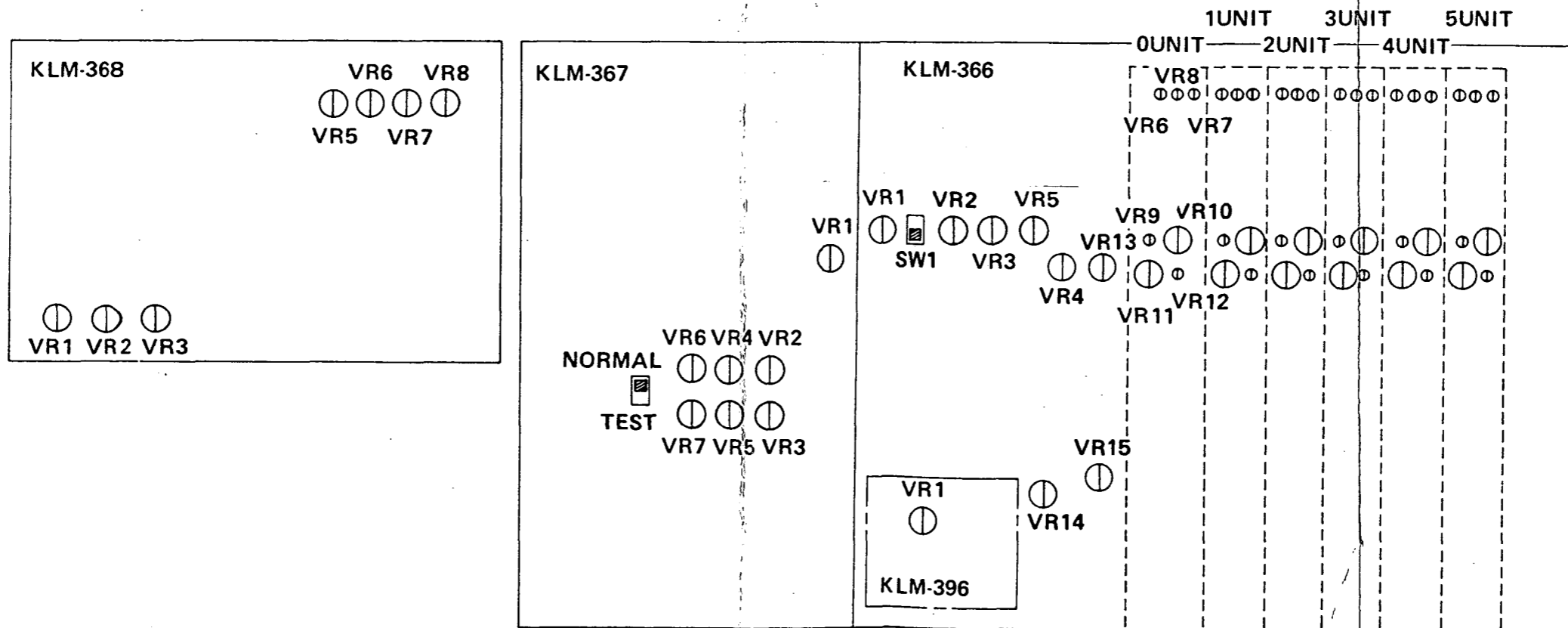
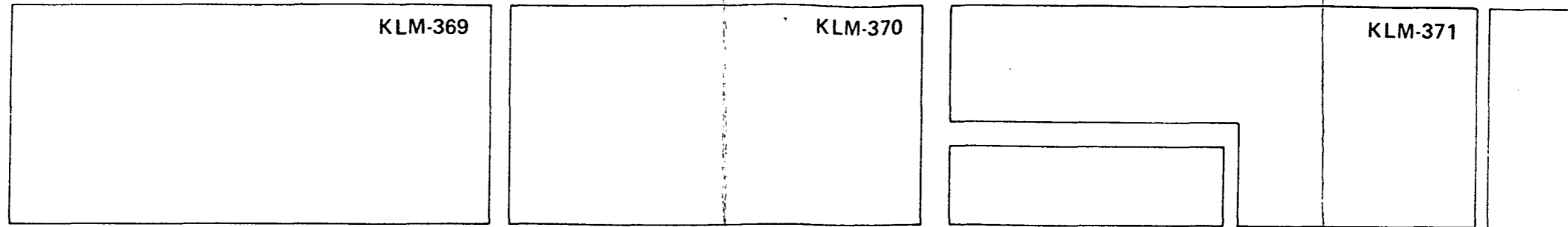

(*) VR2, VR13, VR14, VR15 → NEW PRODUCTION.)

8. ADJUSTMENT PROCEDURE

Caution: This unit has been precisely adjusted at the factory before shipment. Therefore, absolutely do not turn any of the variable resistors other than those required for servicing. Testing and adjustment should be performed only after allowing the unit to warm up for ten minutes. Variable resistor locations are marked on separate charts.

* The following are required for the test procedures:

- Digital voltmeter (DVM) 4-1/2 digit
- Oscilloscope
- Tuner Korg WT-12, etc.
- Audio amp and speaker, or headphones.

1. Please check the following before proceeding.

- 1) Check all connections to make sure they are correct and secure.
- 2) Check memory back-up battery voltage. KLM-367 circuit board battery voltage should be 3.60V~4.10V.

2. Power supply check and adjustment (KLM-376). Use a DVM to check the following test point (TP) voltages. (Obtain ground in front of LED.):

- 1) +15V for TP-J7. Adjust VR3 to obtain +15.000V ±50mV.
- 2) -15V for the right side of TP-R18. Confirm -15.000 mV ±300mV.
- 3) +5V for TP-J2. Adjust VR2 to obtain +5,000 ±10mV.
- 4) -5V for TP-J1. Adjust VR1 to obtain -5.000V ±10mV.

3. KLM-367 check and adjustment.

(1) Reset circuit.

With controls at the normal setting (fig. 1), connect a dummy 56kohm 2P (2-pin) connector to the KLM-376 2P plug (male). If connector not available attach 56K resistor with small test clips (E-Z-Hook or Similar)

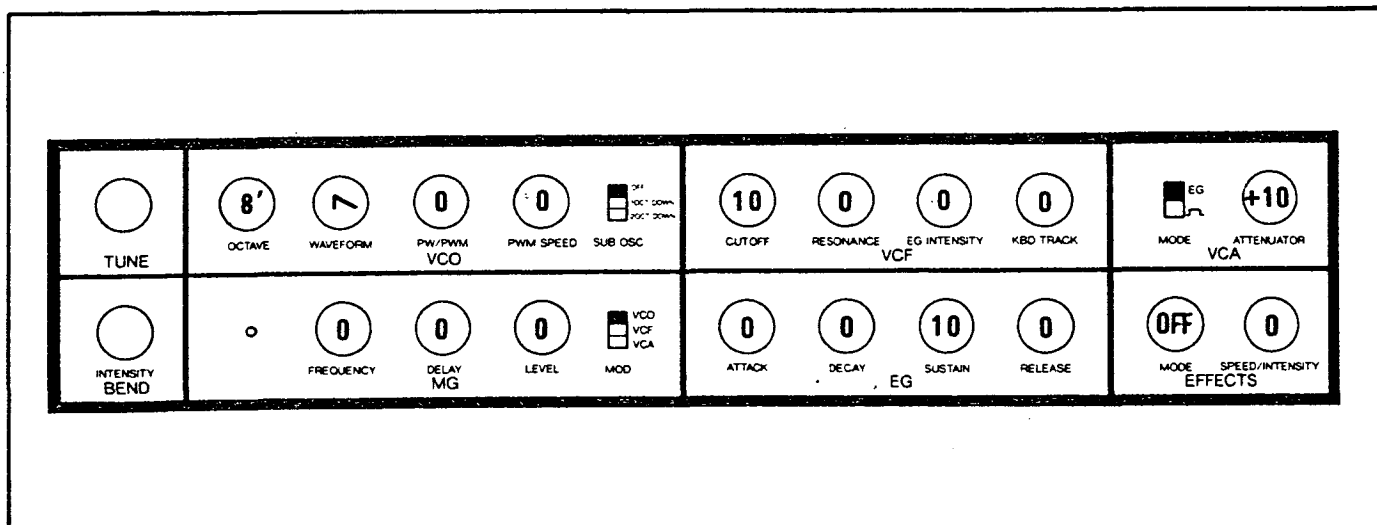

Fig. 1 Normal setting.

1) Turning VR1 from the counterclockwise position towards the clockwise direction, adjust so that the BANK A~D, MANUAL, TAPE ENABLE, and PROGRAM 1 ~ 8 LEDs all light up (instead of only BANK A and PROGRAM 1).

2) Confirm that only the BANK A and PROGRAM 1 LEDs light up when you remove the 56kohm 2P connector.

(2) D/A adjustment.

1) Set MANUAL to ON, CUTOFF to 10, and EFFECT INTENSITY to 0.

2) Set circuit board SW1 to TEST position.

3) Confirm that PROGRAM LEDs 1 & 8 alone light up when the TAPE SW is switched back and forth from DISABLE to ENABLE and back to DISABLE.

4) If LEDs other than 1 and 8 light up, adjust VR6 (offset) and VR7 (width) so that only 1 & 8 light up.

5) Turning VR7 clockwise, adjust so that the lit LEDs shift to 1 & 8. In the shift from 2 & 7 to 1 & 8 there may be some time lag between the two. If this is very large, adjust VR6 to minimize it.

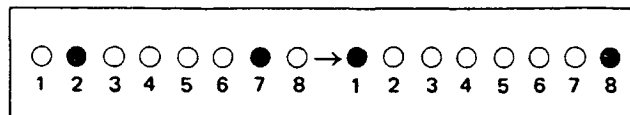

6) Switch the circuit board SW1 to the NORMAL position. Confirm that LEDs 1 & 8 remain lit up without any change.

7) Confirm that output DC click noise is within 6Vp-p when power is switched off.

8) Turn power on and confirm that the BANK A and PROGRAM 1 LEDs light up.

(3) MG adjustment.

Leaving other controls at the normal setting, set MG FREQUENCY to 10, LEVEL to 10, and MOD SW to VCA.

1) Observe connector CN03-5 on oscilloscope.

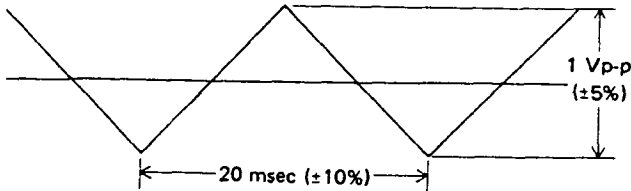

Fig. 2.

2) Adjust VR2 to obtain $1V_{p-p}(\pm 5\%)$ level; adjust VR5 to obtain frequency of 50Hz ($20msec \pm 10\%$). If these values cannot be obtained after replacing IC LM13600, adjust R78 and R52 respectively.

3) Leave the other controls at the same settings as above, but change MG FREQUENCY to 0. Confirm a cycle of 10 ~ 40 sec.

Leave other controls at same settings but change MG FREQUENCY to 4, and DELAY to 10. Confirm that the waveform appears 8 ~ 12 seconds after a key is depressed.

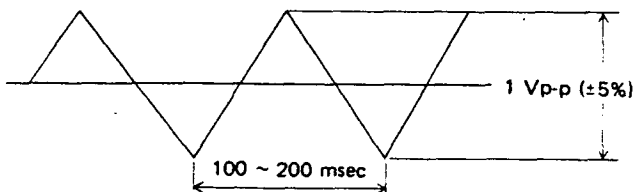

Fig. 3. (LEVEL $1V_{p-p}$; frequency about 10Hz.)

(4) PW/PWM check and adjustment.

Set waveform to PW and PWM SPEED to 0, and PW/PWM to 10.

1) Connect oscilloscope and DVM to CN05-11.

2) Adjust VR3 to obtain $+2.2V (\pm 1\%)$.

3) Change WAVEFORM to PWM and PWM SPEED to 10. Adjust VR4 to obtain a frequency of 20Hz.

Use resistor in series with VR4 if adjustment cannot be obtained in the same way as for the MG.

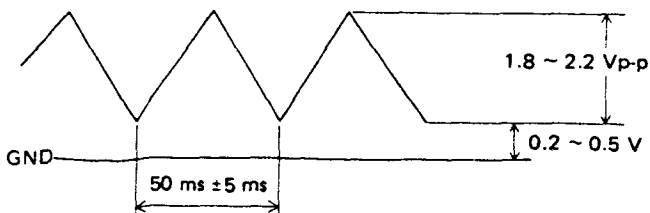

Fig. 4.

4) At this time confirm that there is a DC component of $+0.2 \sim +0.5V$.

4. KLM-366 check and adjustment. Obtain ground at TP5.

(1) VCF offset adjustment.

Leaving other controls at standard settings, set WAVEFORM to PW and PW/PWM to 10.

1) Use oscilloscope or DVM to check Q5 (2SC945) collector.

2) Adjust VR7 to obtain $0mV \pm 2mV$.

3) Repeat steps 1 & 2 for units No. 0 ~ No. 5.

(2) VCA level adjustment.

Set OCTAVE to 4; leave others at normal setting.

1) Connect oscilloscope to SIG OUT (TP-1).

2) Play C3 and adjust VR9 to obtain a sawtooth waveform amplitude of $1V_{p-p} (\pm 5\%)$.

3) Repeat for units No. 0 ~ No. 5.

(3) VCF RESONANCE adjustment.

Set OCTAVE to 8, WAVEFORM to PW, and PW/PWM to 10. Check CN05-7 with DVM and adjust to obtain $0.000V \pm 20mV$. *ADJUST CUTOFF FROM FRONT*
Check CN05-11 with DVM and adjust RESONANCE VR to obtain $8.000V \pm 20mV$. *from front*

Leave other controls at normal setting.

1) Check SIG OUT (TP1) with oscilloscope and frequency counter.

2) Play any single key and adjust VR6 so that the VCF waveform amplitude is $300mV_{p-p} \pm 20mV$.

3) Repeat for units No. 0 ~ No. 5.

(4) VCF f_0 adjustment.

Set RESONANCE to 10; leave others at same setting as above (3).

1) Check oscillation frequency with frequency counter and tuner (WT-12, properly calibrated, chromatic dial set to C).

2) Adjust VR8 to obtain $f_0 = 523Hz (\pm 10 \text{ cent})$.

3) Repeat for units No. 0 ~ No. 5.

4) Turn CUTOFF from 0 to 10 and check to see that each unit's oscillation frequency is 10 ~ 25Hz at 0 and 19 ~ 24kHz at 10; amplitude should be at least $300mV_{p-p}$ throughout.

(5) EG INTENSITY adjustment.

Set WAVEFORM to PW, PW/PWM to 10, CUTOFF to 0, RESONANCE to 10, EG INT to +5. Leave others at normal setting.

1) Check SIG OUT (TP-1) with oscilloscope and frequency counter.

2) Play any single key and adjust VR4 to obtain an oscillation frequency of 5kHz ($\pm 500Hz$) for units No. 0 ~ No. 5.

3) Set EG INT to +3 and check to see that there is no wide variation in pitch between units No. 0 ~ No. 5.

4) Set octave to 4', RESONANCE to 0, EG INT to +5, SUSTAIN to 0, DECAY to 5. Leave others at same setting as 3) above.

Check to see that there is no click noise for units No. 0 ~ No. 5.

(6) KBD TRACK adjustment.

Set OCTAVE to 16', connect DVM to CN05-6, and adjust KBD TRACK VR to obtain $+1.6V$.

Leave others at same setting as (4).

1) C1 ~ C2 should sound approximately like a scale.

2) Adjust VR5 if necessary.

(7) PITCH check and adjustment.

Set OCTAVE to 4'; leave others at normal.

1) Change circuit board slide switch to opposite position.
(away from VR1)

2) Play C6 and adjust VR11 to obtain 0 cent.

3) Repeat step 2) for units No. 0 ~ No. 5.

4) Play C2 and adjust KLM-396 VR1 to obtain 0 cent.
Do this for one unit.

5) Set OCTAVE to 16', play C2 and adjust VR10 to obtain 0 cent.

6) Repeat step 5) for each unit. (VR3 is used to adjust for deviation of all units.)

7) Play C1, C2, C3, C4, C5, and C6, and confirm that each unit's deviation is within specifications.
(Refer to Poly-6 deviation standards.)

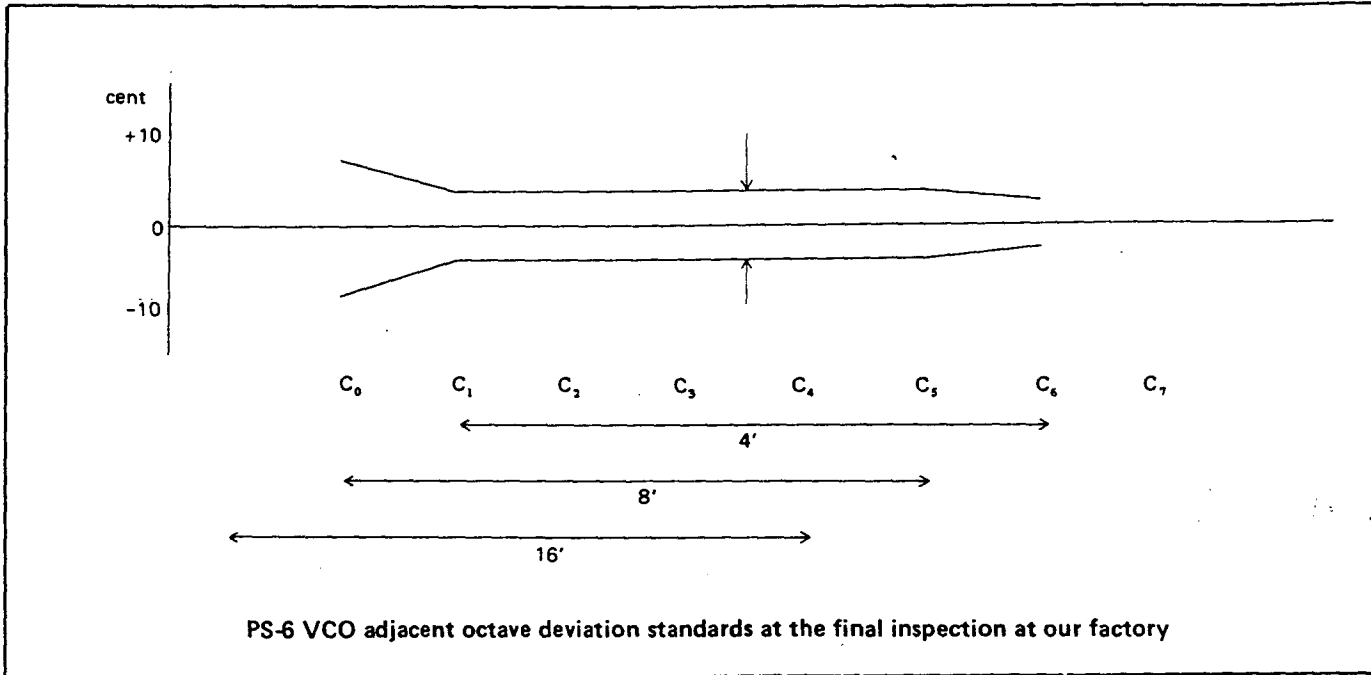

8) Check to confirm that deviation between adjacent octaves is within specifications. (for unit 0 only.)
(Refer to VCO adjacent octave deviation standards.)

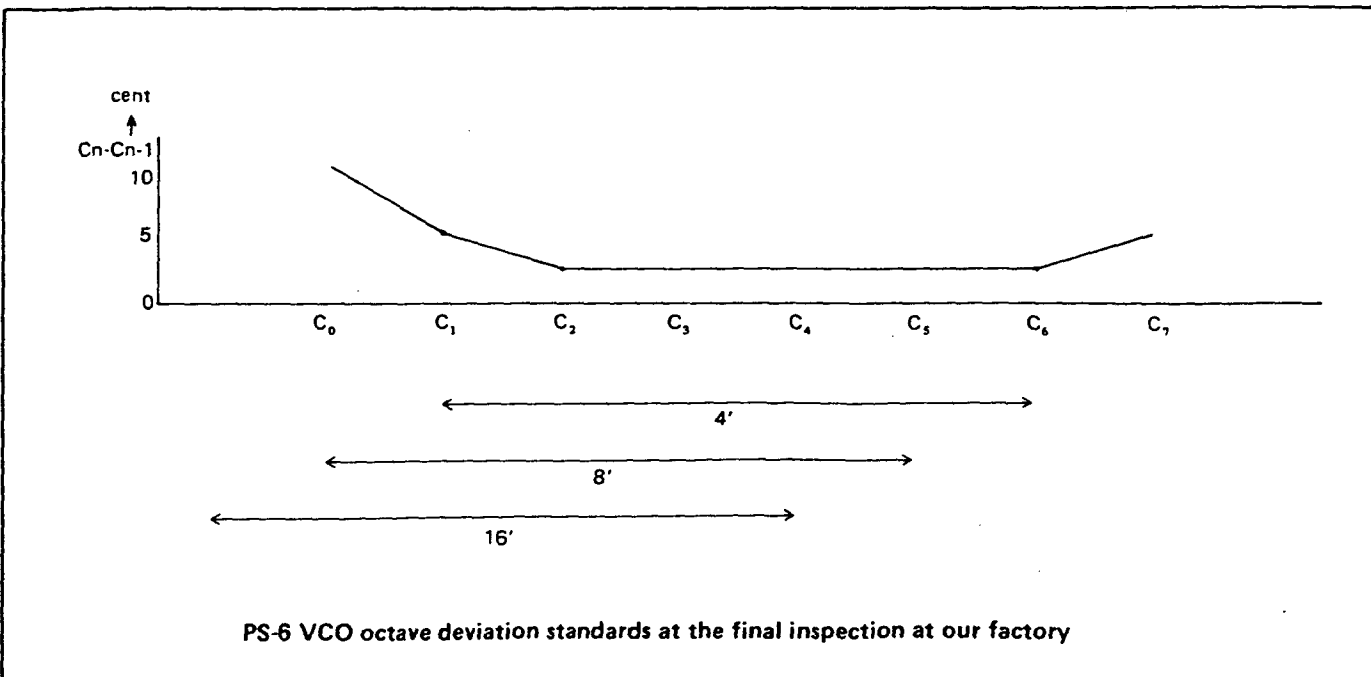

- 9) Confirm that difference between 4' D[#]4 and E4 is within 2 cents.
(Switch between POLY and UNISON and check unit 0 only.)
- 10) Switch SW1 to the front while playing C6 (stretch tuning) and confirm +8 ~ +12 cent.
- 11) Confirm difference of no more than 2 cents between 4' G5 and G[#]5. Unit 0 only is OK.
- 12) Confirm that KLM-366'S VR1 is approximately in the center position and not turned in the clockwise or counterclockwise directions.
- (8) EG TIME check and adjustment.
 - 1) Attack time adjustment.
Check CN05-12 with DVM and adjust ATTACK VR to obtain +0.9V ±20mV. Set SUSTAIN to 0; leave others at normal setting.
 - 2) Test top side of R143 10K with oscilloscope. (Set sweep mode to normal.)
 - 3) Set ARPEGGIO to ON, ARPEGGIO SPEED to 2.5, LATCH to ON, and UNISON to ON.
 4. Play any single key and adjust VR12 to obtain an attack time of 250msec ±10msec. See fig. 5.

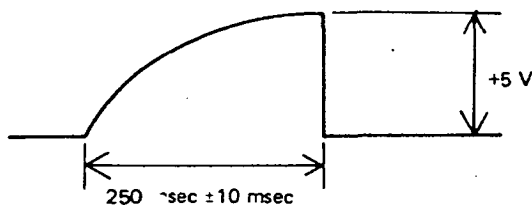

Fig. 5

- 5) Repeat steps 2) ~ 4) for units 0 ~ 5.
- 6) Set ATTACK to 10; leave others at setting 1).
Repeatedly play a single key and confirm that differences between the fade-out of the six notes are within 5 seconds and that all fade out within 15 ~ 25 seconds.
- 7) DECAY TIME check.
Set OCTAVE to 4', WAVEFORM to PW, PW/PWM to 10, CUTOFF to 2, RESONANCE to 10, EG INTENSITY to +3, DECAY to 8, SUSTAIN to 0, ARPEGGIO to ON, ARPEGGIO SPEED to 1 ~ 3, LATCH to ON, and KEY ASSIGN MODE to POLY. Leave others at normal.
Listen to each unit and check to see that there are no deviations.
- 8) RELEASE TIME check.
Set DECAY to 0, SUSTAIN to 10, and RELEASE to 8; leave others at same as 7) above.
Listen to each unit and check to see that there are no deviations.

5. KLM-368 check and adjustment.

- (1) HEADPHONE AMP OFFSET adjustment.
 - 1) Use normal setting. Connect oscilloscope and DVM to TP-4 (GND is TP-6). Adjust VR6 to obtain offset of 0mV ±20mV.
 - (2) HEADPHONE AMP LEVEL adjustment.
Set OCTAVE to 4'; leave others at normal. Check point is same as (1) above.
 - 1) Play C3 and adjust VR5 to obtain a sawtooth waveform amplitude of 0.3Vp-p (±5%).
 - 2) Check to be sure there is no waveform distortion at this point.
 - (3) OUTPUT AMP OFFSET adjustment.
Set WAVEFORM to PW, PW/PWM to 10, MG FREQUENCY to 7, LEVEL to 10, and MOD to VCA.
Check SIG OUT (TP-5) with oscilloscope.
 - 1) Adjust VR7 to minimize waveform amplitude. See fig. 6.

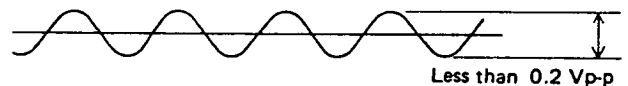

Fig. 6

- (4) OUTPUT AMP LEVEL adjustment.
Set OCTAVE to 4'; leave others at normal.
 - 1) Play C3 and adjust VR8 to obtain a sawtooth waveform amplitude of 3Vp-p (±5%).
 - 2) Confirm that click noise occurring when power is turned off is less than volume of sound made by playing C3. DC click noise amplitude should be no greater than 6Vp-p.
- (5) BBD CLOCK adjustment.
Set EFFECTS MODE to ENSEMBLE, SPEED/INTENSITY to 10. Leave others at normal.
 - 1) Check TP-1 with oscilloscope.
 - 2) Adjust VR1 to obtain maximum clock cycle of 30μsec. See fig. 7.

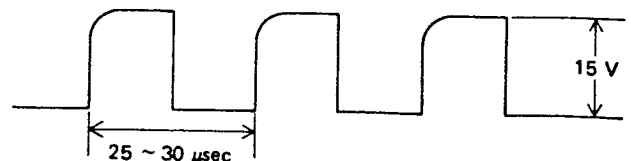
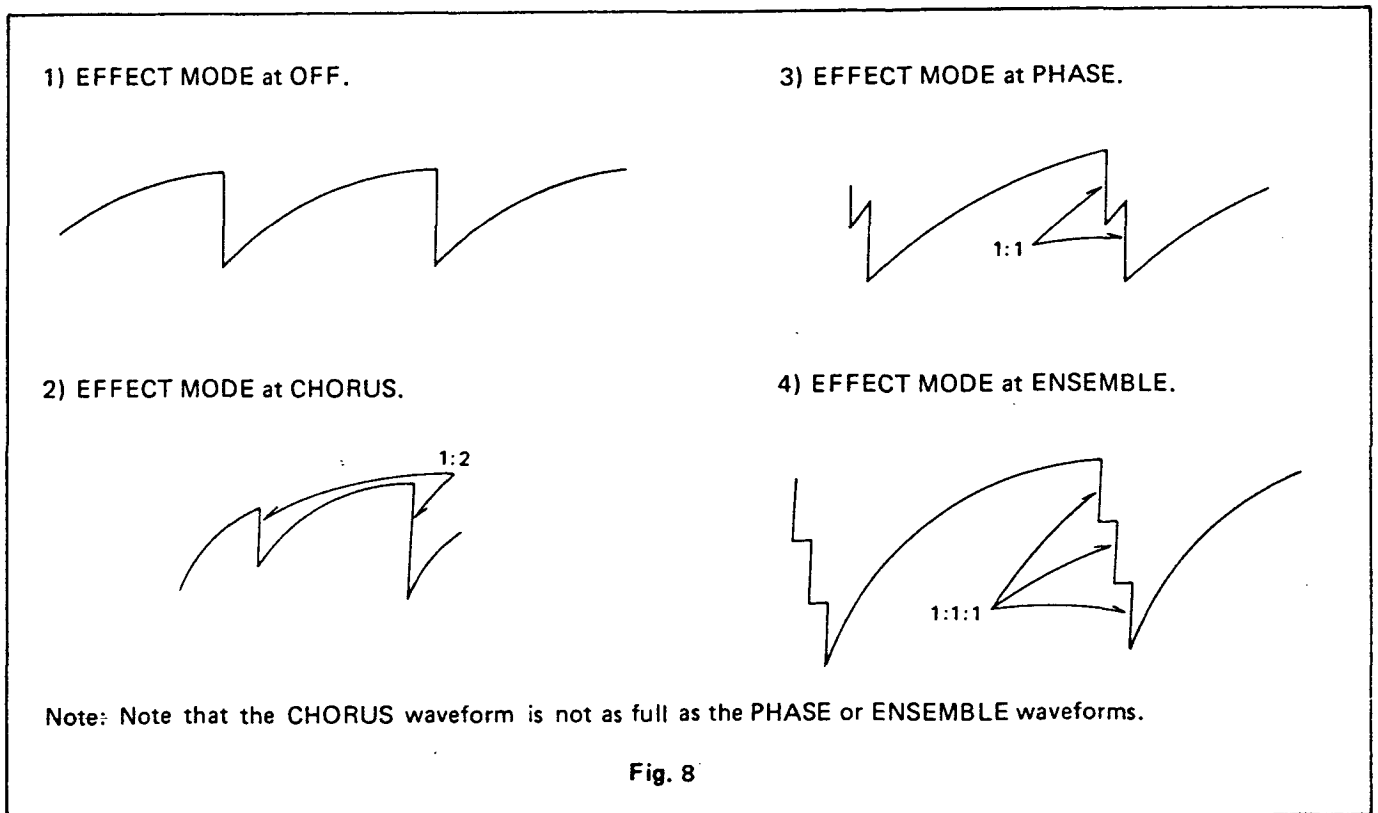

Fig. 7

- 3) Check TP-2 with oscilloscope.
- 4) Adjust VR2 to obtain maximum clock cycle of 30μsec.
- 5) Check TP-3 with oscilloscope.
- 6) Adjust VR3 to obtain maximum clock cycle of 30μsec.

- 7) Set INTENSITY to 0 and check TP-3 with oscilloscope.
Set EFFECT to ENSEMBLE and confirm that the minimum ENSEMBLE clock time is $4 \sim 8\mu\text{sec}$.
Set EFFECT to PHASE and confirm that maximum PHASE clock cycle is $8 \sim 12\mu\text{sec}$, and minimum is $1.5 \sim 3\mu\text{sec}$.
- 8) Set INT to 10 and confirm that maximum PHASE clock cycle is $2.5 \sim 3.5\mu\text{sec}$, and minimum is $1.0 \sim 2.0\mu\text{sec}$.

- 9) SET INT to 0 after completing the above.
- 10) Set EFFECT to CHORUS and confirm maximum clock cycle of $16 \sim 22\mu\text{sec}$, and minimum of $8 \sim 12\mu\text{sec}$.
- (6) EFFECT WAVEFORM check.
Use normal setting and check TP-5 with oscilloscope (1V, 2msec.) Play C1 and check the various waveforms while switching from one EFFECT MODE to another.



Sales Support +
Product Mgr

9. PARTS LIST

PARTS NAME SPECIFICATIONS	PART CODE	QTY
CARBON RESISTORS (Not listed)		
SOLID RESISTORS		
1/4 KY 10M	11013810	5
22M	11013822	1
BLOCK RESISTORS		
RKC1/8 B5J 10K	13435100	1
B8J 10K	13635100	3
METAL FILM RESISTORS		
1/4 FYLC 100Ω	12313100	1
102	12313102	2
243	12313243	1
249	12313249	1
324	12313324	1
464	12313464	1
499	12313499	1
1.00K	12314100	10
1.87	12314187	1
2.00	12314200	1
2.15	12314215	1
3.16	12314316	5
3.24	12314324	1
4.53	12314453	1
4.87	12314487	1
10.0	12315100	10
10.7	12315107	1
11.3	12315113	1
12.1	12315121	1
12.7	12315127	1
15.0	12315150	5
17.4	12315174	1
20.5	12315205	1
21.5	12315215	1
30.1	12315301	1
36.5	12315365	1
43.2	12315432	6
49.9	12315499	3
61.9	12315619	1
66.5	12315665	1
100 K	12316100	8
301	12316301	2
24.0	12315240	1
27.0	12315270	6
37.4	12315374	1
68.0	12315680	1
34.8	12315348	1
523	12316523	1
1/8 BY 100 K	12066100	6
200	12066200	8
SEMI-FIXED RESISTORS		
10φ B 220 Ω (R)	35201122	3
470	35201147	2
2.2	35201222	6
3.3	35201233	1
4.7	35201247	1
10	35201310	1
15	35201315	1
22	35201322	1
47	35201347	1
100	35201410	16
15 SOLID	35001315	6
100	35001410	18
1MΩ	35001510	6

PARTS NAME SPECIFICATIONS	PART CODE	QTY
MYLAR CAPACITORS		
50V 0.001 μFK	20003410	4
0.0012	20003412	8
0.0022	20003422	4
0.0033	20003433	1
0.0047	20003447	2
0.01	20003510	27
0.022	20003522	3
0.033	20003533	2
0.047	20003547	45
0.015	20003515	1
0.1	20003610	2
0.15	20003615	3
0.0068 μFJ	20002468	18
CERAMIC CAPACITORS		
50V 10 PF D	21253210	3
22 J	21256222	4
33	21256233	4
100	21256310	5
470	21256347	10
560	21256356	6
680 K	21277368	8
0.01 μF Z	21289510	52
25V 0.1 μF M	21238610	2
POLYPROPYLENE CAPACITORS		
PPC 100V 6200PF	26000462	6
ELECTROLYTIC CAPACITORS		
50V 1 μF	23515110	11
2.2	23515122	1
3.3	23515133	4
25V 10	23511210	2
16V 10	23507210	46
22	23507222	6
47	23507247	2
100	23507310	6
35V 2200	23613422	1
4700	23613447	1
50V 0.33 MS	23315033	1
2.2 "	23315122	2
16V 10 "	23307210	1
50V 1.5 "	23315115	1
POTENTIOMETERS		
EVH-5LA 802 B14	36005800	16
EVH-6LA 802 B14	36010800	1
EVH-5LA 802 C16	36007400	1
K1611 16KC	36014200	1
K1611008TE 10KB	36014000	1
ROTARY SW		
SRM-1033141	37002300	2
1034362	37001500	1
101B	37002600	1
TACT SW		
KHC-11901	37503400	19
SLIDE SW		
SSB-122019	37301000	4
12300	37303500	5
12202	37301200	2
SSS-322	37303400	2
1801-0121	37501600	1

PARTS NAME SPECIFICATIONS	PART CODE	Q'TY
IC		
HD14011BP	32004008	4
14013	32004009	3
14024	32004011	1
14027	32004025	6
14042	32004013	6
14051	32004017	10
14066	32004004	5
14069UBP	32004019	4
14070B	32004003	1
14174	32004020	1
14175	32004026	2
SN74LS04	32021028	1
74LS08	32021029	2
74LS75	32021030	4
LM13600N	32022006	4
13600N. SELECTED (RED)	32022091	1
324N	32021008	3
339C	32021027	1
MPC393C	32001027	5
NJM4560	32009006	4
4556	32009002	1
4558DV	32009001	27
TL071	32021013	1
072	32021011	10
μPD8048-345	32001037	1
8049-C217	32001036	1
TC-5514 APL-3	32003006	1
MC1408L8	32020023	1
MN3004	32002006	3
NE571	32025002	2
555	32021012	1
M5230L	32011001	1
SSM2044	32029004	6
2056	32029006	6
TRANSISTORS		
2SA733AK	30000727	15
2SA798G	30001007	4
2SB744AP	30100328	2
2SD794AP	30300528	2
2SC945AK	30200327	33
2SC945AK or P SELECTED	30200399	12
2SC1583 or F	30201106	4
FET		
2SK30A TM-GR	30600232	1
2SK30A TM-O	30600115	11
DIODES		
1S 1555	31000100	123
1S 1885	31000200	4
ZENER DIODES		
02BZ3.9A	31102000	1
LED		
PR3932S (φ3)	31201400	3
LT8001P	31201500	7
PHOTO COUPLERS		
HTV P-1501	33000800	1
CRYSTAL OSCILLATOR		
EFO-A6R0M01 (6 MHz)	33500900	2

PARTS NAME SPECIFICATIONS	PART CODE	Q'TY
THERMISTORS		
TD5-A110DA (100 Ω)	18032310	3
A150DA (500 Ω)	18032350	1
TD5-C210DA (1K)	18032410	1
C250DA (5K)	18032450	1
PHONEJACK		
STREO 0927#02	45300400	1
2P 0922#01	45300600	3
3P 0902#01	45300500	2
2P 0983#00	45300800	1
BATTERY		
150MAH 3.6V	52000900	1
PCB		
KLM-366	34036600	1
367	34036700	1
368	34036800	1
369	34036900	1
370	34037000	1
371	34037100	1
372	34037200	1
376	34037600	1
POWER TRANSFORMER		
TA-001 100V, 117V	40006200	1
TB-001 220V, 240V	40006300	1
FUSE HOLDER		
S-N5053	51501600	6
SPARK KILLER		
PME-271M533	21900300	1
NOISE FILTER		
TDK NOISE FILTER	12800100	1
WOODEN CASE		
KOC-D10005	64507900	1
FRONT PANEL		
KOC-C20111	64053500	1
METAL FITTING OF KLM-369		
KOC-C40399	64053600	2
METAL FITTING OF KLM-371		
KOC-C30179 2	64053800	1
KOC-C30179 1	64053700	1
PHONE JACK PLATE		
KOC-C30178	64054000	1
POWER PLATE		
KOC-C40397	64053400	1
RADIATION BOARD		
KOC-C40406	56001800	1
METAL FITTING OF KLM-376		
KOC-C40405	64053200	1
CONTROL PANEL		
KOC-E20028	64607900	1
CONTROL WHELL		
KOC-E40091	64608000	2

PARTS NAME SPECIFICATIONS	PART CODE	Q'TY
PCB RAIL		
	64608200	1
MODEL NUMBER PLATE		
KOC-C40144	64050500	1
KEY BOARD		
ESK-701 61 KEYS	42001900	1

NOTE

This is the modification in circuit. Please make necessary treatment for unmodified sets.

- (1) Please fix yellow KBD wires to KBD chasis with cord keeper in order to keep the wires away from IC33 on PC-Board KLM-367. This modification prevents wrong operation of the programmer.
- (2) Connect the GND side of the battery on P.C.-board KLM-367 to GND No. R2, R3 and R4 on P.C.-board KLM-370.
- (3) CONNECT the GND of PHONE JACKS to shield sheet under KLM-368.
- (4) Modification to improve the higher frequency response has been made on KLM-368 in order to improve the tone quality from the June production. The circuit diagram in this manual fits for the modification.

Constants for the old production are as follows:

R167	2.2K Ω	R166	1K Ω
R197	10 K Ω	C78	0.0047 μ
R196	100 K Ω		

OUTPUT AND LEVEL adjustment

Same setting as P23 (4).

Play C3 and adjust VR8 to obtain a sawtooth waveform, amplitude of 2.0Vp-p ($\pm 5\%$).

- (5) The circuit diagram and the P-C Board for KLM-366 have been modified from the June production. Accordingly, adjustment procedure for KLM-366 has been changed as follows:

1) VCF for adjustment (Change in R58 and R64)

Turn CUTOFF from 0 to 10 and check to see that each unit's oscillation frequency is 6.5~20 Hz at 0 and 25~31 KHz at 10. Amplitude should be at least 300mVp-p throughout.

2) KBD TRACK offset adjustment

Same setting as p2 (6)

Play C1 and turn the KBD TRACK knob from 0 to 10. Confirm that the difference between these two pitches is within 20 cents. If not, adjust VR-13.

3) PITCH check and adjustment

VR15 on KLM-366 is equal to VR1 on KLM-396.

Confirm that difference between 4' D#4 and E4 is within 2 cents. If necessary, adjust VR14.

VR2 is used to adjust for deviation in higher pitch range totally for all the 6 units.

D. Gilman name was

Abou

Gambou

Hugh Carl M

Hypen

Middle

TWIZ ZEN

0181 783 1656

Phil Tyler

0181 961 0961

DGon Ltd

0831 261 757

3 Colton way

Park Ridge

M10 6JZ

5-88

Free Manuals Download Website

<http://myh66.com>

<http://usermanuals.us>

<http://www.somanuals.com>

<http://www.4manuals.cc>

<http://www.manual-lib.com>

<http://www.404manual.com>

<http://www.luxmanual.com>

<http://aubethermostatmanual.com>

Golf course search by state

<http://golfingnear.com>

Email search by domain

<http://emailbydomain.com>

Auto manuals search

<http://auto.somanuals.com>

TV manuals search

<http://tv.somanuals.com>