



LXD381 — Evaluation Board for Octal E1 Applications

Developer Manual

January 2001

As of January 15, 2001, this document replaces the Level One document
LXD381 — Evaluation Board for Octal E1 Applications User Guide.

Order Number: 249213-001



Information in this document is provided in connection with Intel® products. No license, express or implied, by estoppel or otherwise, to any intellectual property rights is granted by this document. Except as provided in Intel's Terms and Conditions of Sale for such products, Intel assumes no liability whatsoever, and Intel disclaims any express or implied warranty, relating to sale and/or use of Intel products including liability or warranties relating to fitness for a particular purpose, merchantability, or infringement of any patent, copyright or other intellectual property right. Intel products are not intended for use in medical, life saving, or life sustaining applications.

Intel may make changes to specifications and product descriptions at any time, without notice.

Designers must not rely on the absence or characteristics of any features or instructions marked "reserved" or "undefined." Intel reserves these for future definition and shall have no responsibility whatsoever for conflicts or incompatibilities arising from future changes to them.

The LXD381 may contain design defects or errors known as errata which may cause the product to deviate from published specifications. Current characterized errata are available on request.

Contact your local Intel sales office or your distributor to obtain the latest specifications and before placing your product order.

Copies of documents which have an ordering number and are referenced in this document, or other Intel literature may be obtained by calling 1-800-548-4725 or by visiting Intel's website at <http://www.intel.com>.

Copyright © Intel Corporation, 2001

*Third-party brands and names are the property of their respective owners.



Contents

1.0	General Description	5
1.1	Features	5
2.0	Evaluation Board Set-Up.....	7
2.1	LXD381 Packing List.....	7
2.2	Equipment Requirements.....	7
2.3	Power Connections	7
2.4	Loopback Mode Selection.....	7
2.5	Receive Polarity Selection.....	8
2.6	Output Enable Selection.....	8
2.7	Unused Switches.....	8
2.8	Back-End Interface Connection.....	8
2.9	Line Interface Connection	9
2.10	Line Interface Circuit	9
2.11	Board Protection.....	9
3.0	Evaluation Board Schematics.....	10

Figures

1	LXD381 Evaluation Board	6
2	S2 Factory Switch Settings	8
3	Typical Back-End Connector.....	9
4	Evaluation Board Schematic — Data/Control	10
5	Evaluation Board Schematic — Digital I/O.....	11
6	Evaluation Board Schematic — Analog 1	12
7	Evaluation Board Schematic — Analog 2	13

Tables

1	LOOP0 - 7 Switch Settings.....	7
---	--------------------------------	---

1.0 General Description

The LXD381 evaluation board is a versatile tool for engineers designing E1 short haul applications using the LXT381.

The evaluation board operates in Hardware mode only. All device and channel controls are set using jumper blocks and DIP switches.

The board provides banana jacks for both power and line interface connections. Connectors are provided for each framer or back-end ASIC interface. An E1 pattern generator/analyzer may be used to provide external signals for evaluation.

1.1 Features

- Hardware controllable
- ZIF LQFP socket for easy swapping of LXT381
- Banana jacks for power and line interfaces
- 10-pin connectors for framer/ASIC interface
- Socketed termination components for easy experimentation
- Built-in overvoltage protection for line interface and power supply

Figure 1. LXD381 Evaluation Board

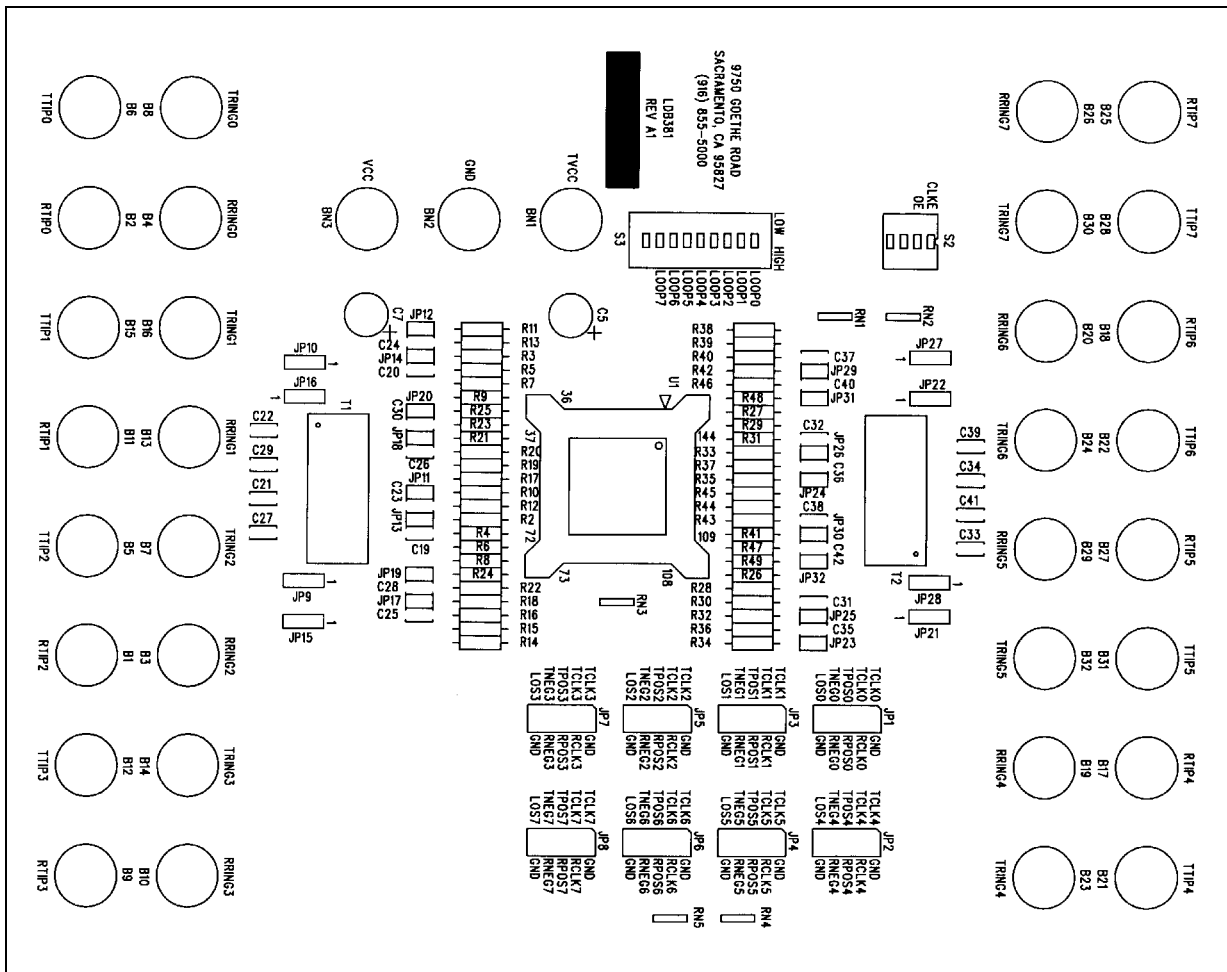

2.0 Evaluation Board Set-Up

Caution: CMOS devices are static (ESD) sensitive. Take all industry standard precautions when handling the evaluation board, the LXT381 chip and other sensitive electronic components.

Before proceeding with any evaluation board operations, review the specifications for the LXT381 transceiver.

2.1 LXD381 Packing List

The evaluation board kit contains the following components:

- LXD381 board with LXT381 device installed.
- LXD381 User Guide.
- LXT381 Data Sheet.

2.2 Equipment Requirements

The evaluation board kit includes all the circuit components needed for a successful evaluation. However, the following lab equipment is required:

- Power Supply (+3.3 VDC).
- Telecom cable or cable simulator (optional).
- E1 pattern generator/analyzer

2.3 Power Connections

The evaluation board has two power planes (VCC and TVCC) each of which is tied to a separate red colored banana jack. Connect the +3.3 VDC power supply to both the VCC (B1) and TVCC (B3) banana jacks. Connect the power supply ground lead to the black banana jack (B2).

2.4 Loopback Mode Selection

The LXT381 LOOP signals for channels 0 through 7 are set by the switches in switch block S1. As shown in [Table 1](#), these switches have three positions to select Remote Loopback, Analog Loopback or No Loopback.

Table 1. LOOP0 - 7 Switch Settings

S1 Switch Position	Operation
High	Analog Loopback
Center	No Loopback
Low	Remote Loopback

2.5 Receive Polarity Selection

The polarity of RPOS/RNEG is determined by the CLKE switch in switch block S2. When the CLKE switch is OFF, RPOS/RNEG are active Low. When set to the ON position, RPOS/RNEG are active High. Note that the CLKE switch controls the LXT381's RPOL pin.

2.6 Output Enable Selection

The OE switch in switch block S3 controls the operation of the LXT381 output drivers. For normal operation (driver outputs enabled), set the OE switch to the ON position. Setting the OE switch to OFF forces the output drivers to the high impedance state.

2.7 Unused Switches

Switches 3 and 4, in switch block S2, have no function on the LXD381 and should be set to the OFF position. [Figure 2](#) shows the factory default settings for switch block S2.

Figure 2. S2 Factory Switch Settings

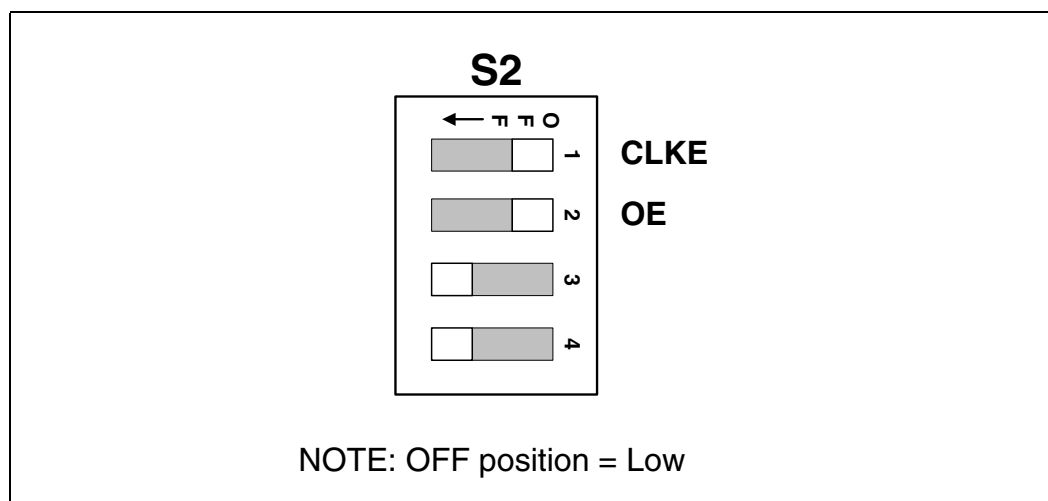

2.8 Back-End Interface Connection

Eight 10 pin connectors (JP1 - JP8) provide access to the LXT381 digital signals to allow interfacing the back-end Framer/Mapper or ASIC with an external pattern generator. [Figure 3](#) shows a typical connector (JP1 for channel 0) with the factory installed jumper connecting RCLK to TCLK. This jumper is normally installed when feeding analog test data from the line interface (TIP and RING).

Figure 3. Typical Back-End Connector

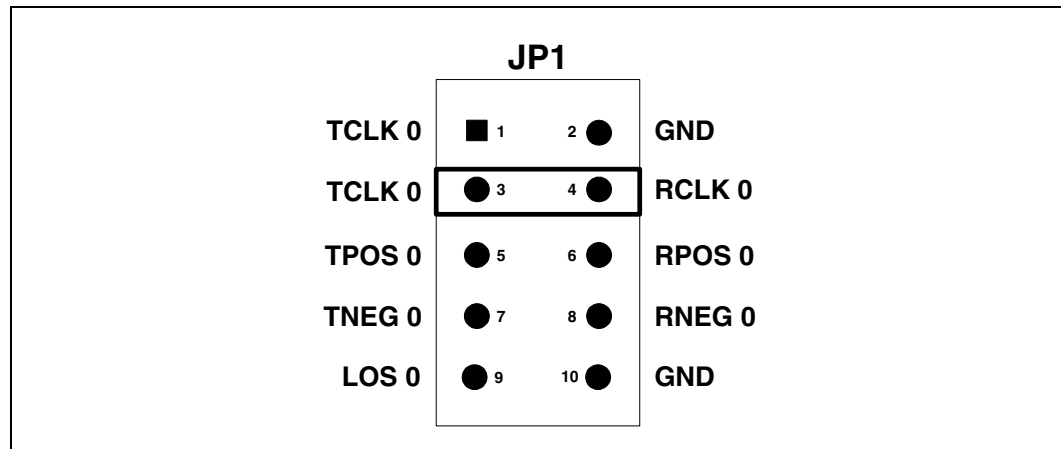

2.9 Line Interface Connection

Access to the line interface is provided through the green and white banana jacks. The TIP signal is routed to the white jacks for both transmit and receive directions. The RING signal is routed to the green jacks for both directions.

2.10 Line Interface Circuit

Two octal transformers are used for channels 0 to 3 and 4 to 7. Transformers, resistors and capacitors for channels 0 and 4 are socketed for easy swapping (see the LXT381 data sheet for line interface information). Jumper blocks are provided to configure the receive transformer operation for 1:1 or 1:2 turns ratio (see “[Evaluation Board Schematics](#)” on page 10). Factory installed jumpers configure the transformers for a 1:1 ratio.

2.11 Board Protection

The evaluation board provides line surge protection for both the power supply and the line. Two transient voltage suppressors (TVS) are included for power supply protection. The E1 line interface transmitters are protected with Schottky diodes and the receivers are protected by series input resistors. This protection is sufficient for G.703 Annex B compliance.

3.0 Evaluation Board Schematics

Figure 4. Evaluation Board Schematic — Data/Control

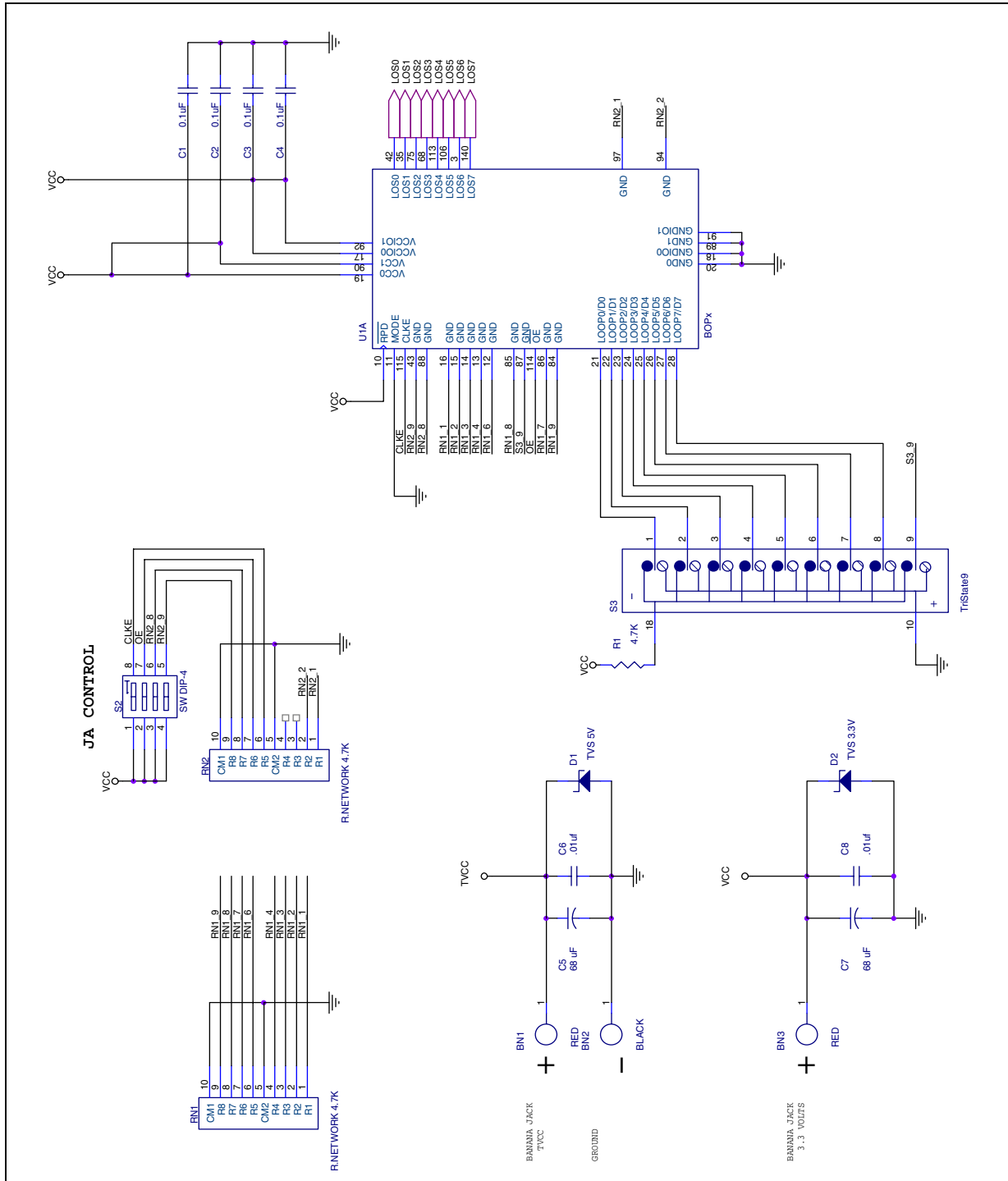

Figure 5. Evaluation Board Schematic — Digital I/O

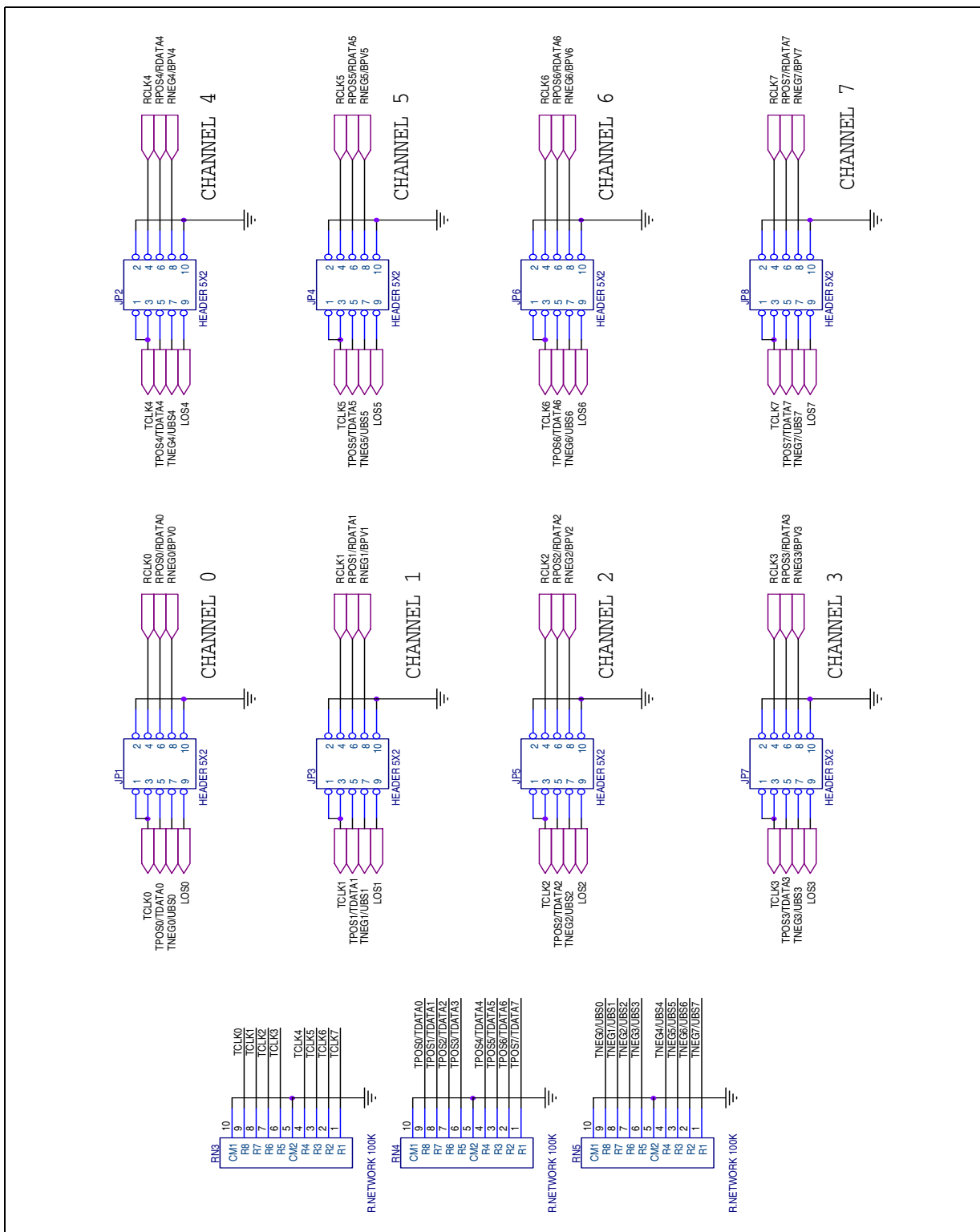

Figure 6. Evaluation Board Schematic — Analog 1

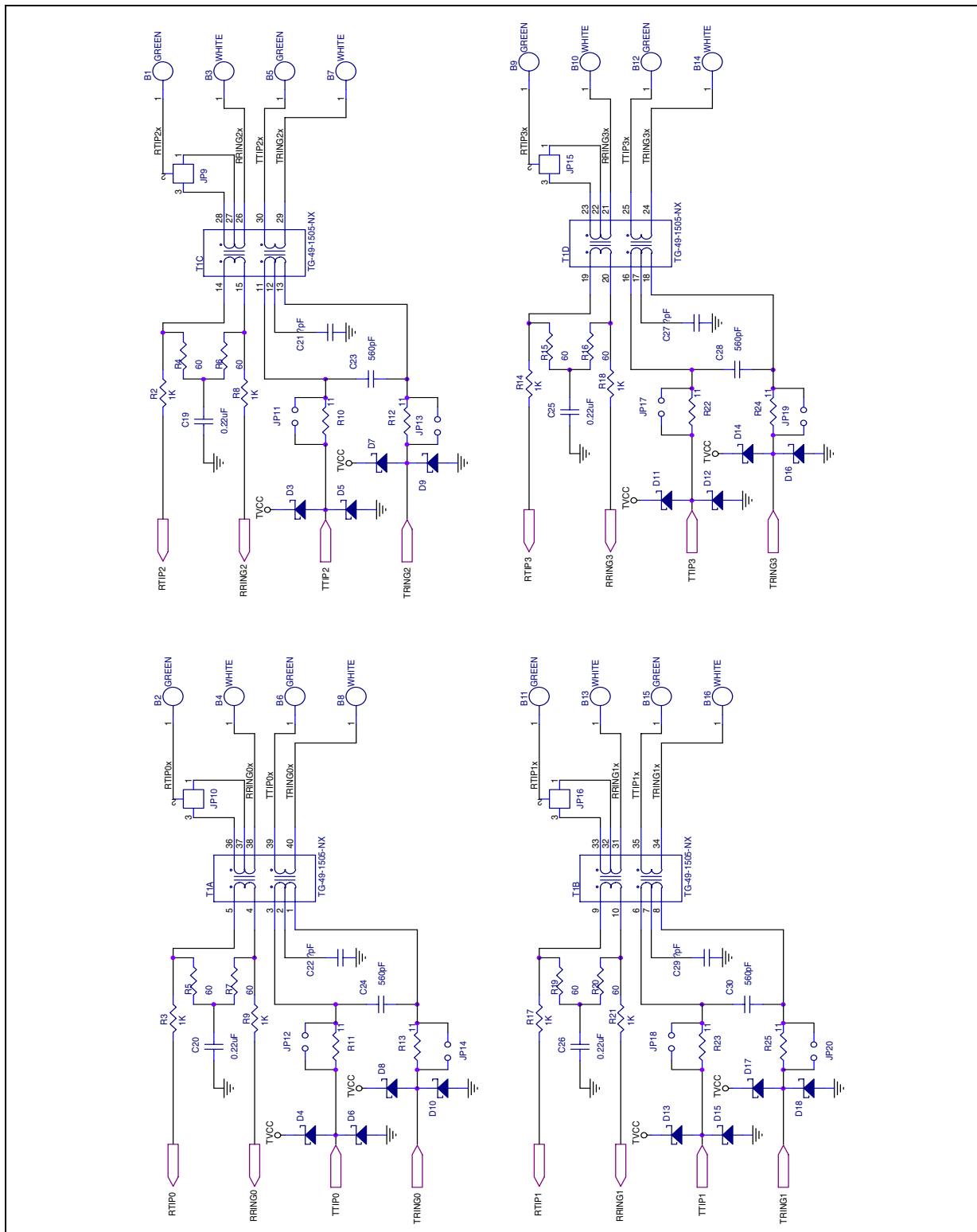
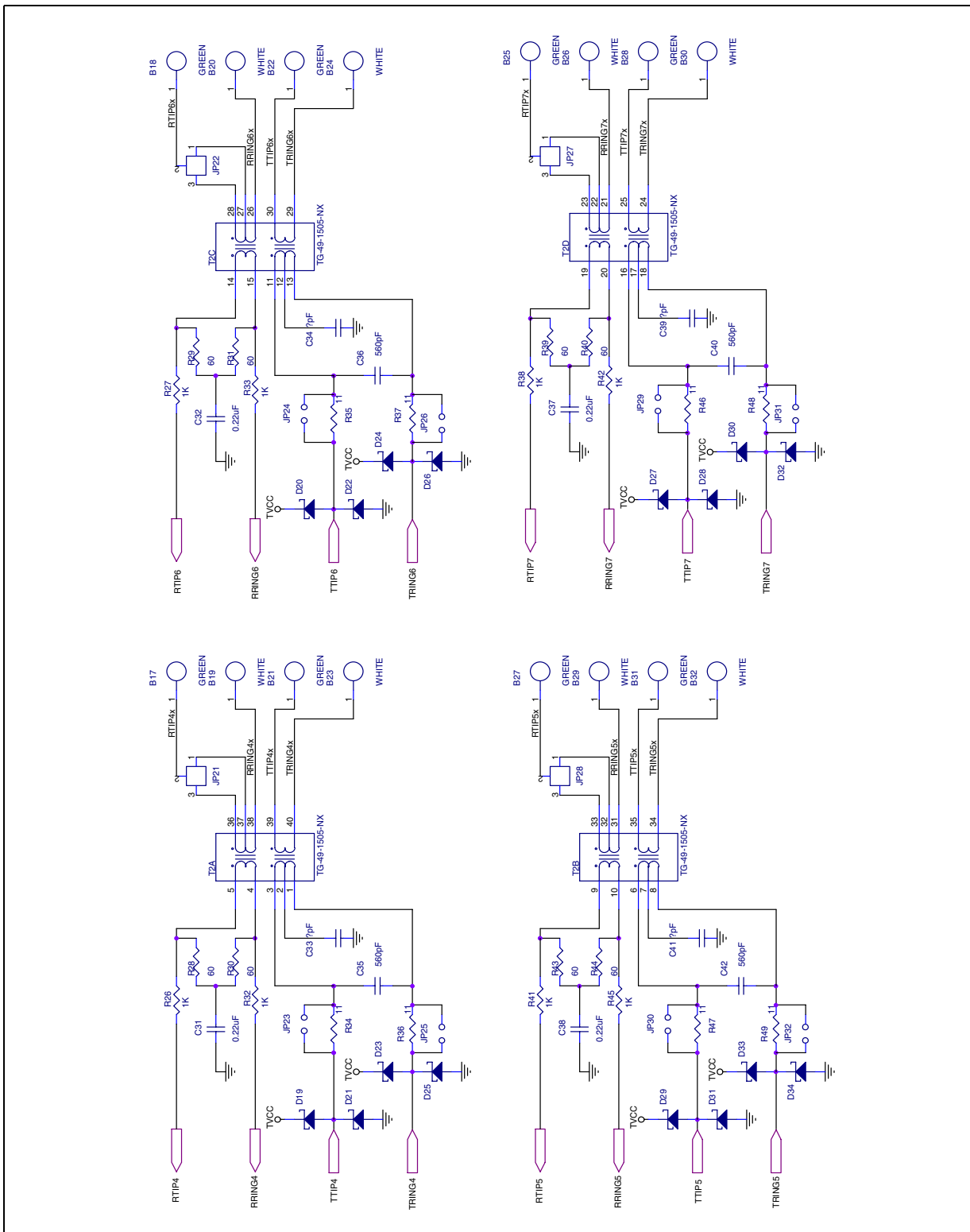

Figure 7. Evaluation Board Schematic — Analog 2



Free Manuals Download Website

<http://myh66.com>

<http://usermanuals.us>

<http://www.somanuals.com>

<http://www.4manuals.cc>

<http://www.manual-lib.com>

<http://www.404manual.com>

<http://www.luxmanual.com>

<http://aubethermostatmanual.com>

Golf course search by state

<http://golfingnear.com>

Email search by domain

<http://emailbydomain.com>

Auto manuals search

<http://auto.somanuals.com>

TV manuals search

<http://tv.somanuals.com>