

IM2000S

**HIGH PERFORMANCE
MICROSTEPPING
CONTROLLER ASIC**



FEATURES

- IM2000S Offers a Complete Microstepping Control System in a 64 Pin QFP Package
- Up to 10MHz Step Clock Rate
- Internal Sine/Cosine Generator
- PWM Phase Current Control
- Minimal External Components
- Automatic Current Reduction
- 14 Selectable Resolutions, in Both Decimal and Binary
- Number of Microsteps Per Step can be Changed On-The-Fly Without Motor Movement Interruption
- Up to 51,200 Steps/Rev
- Standalone or Buss Modes
- Single +5 VDC Power Supply
- Short Circuit and Over Temperature Protection Inputs
- Fault Output
- On Full Step Output
- Anti-Resonance Circuitry

DESCRIPTION

The IM2000S is a high performance microstepping controller that incorporates a sine/cosine signal generator, anti-resonance circuitry, PWM current control and much more in one monolithic IC. The IM2000S combines hardware intense functions together with innovative features to provide designers with a powerful yet simple solution for their high volume OEM products.

Never before has any motion product integrated all the digital control into one monolithic IC. This high degree of integration can significantly reduce design time as well as driver size.

Beyond the integration of a complete microstepping control system, the IM2000S has unique features that give designers unprecedented control over motor movement. These features include 14 selectable resolutions (in both decimal and binary) that can be changed at any time without motor movement interruption. There is no need to reset the controller. This allows the user to rapidly move long distances, yet precisely position the motor at the end of travel without the need or expense of a complex controller.

Another valuable feature is an "On Full Step" output which indicates when the motor is at an electrical full step. This output can be used to reduce the overhead needed to track position when making long moves.

The development of proprietary circuits has minimized ripple current, while maintaining a 20 KHz chopping rate. This prevents additional motor heating that is common with drivers requiring higher chopping rates. Now low inductance stepper motors can be used to improve high speed performance and peak system efficiency.

The IM2000S needs only clock and direction inputs to control the

motor and will interface directly to discrete bridges or common monolithic bridge ICs.

Designers can now place drivers directly on their PC boards with all the necessary control in an ultra small 64 pin QFP package.

Size, price and time-to-market are three crucial aspects in today's competitive markets and the IM2000S offers the ability to reduce all three.

PACKAGING INFORMATION

Dimensions in Inches (mm)

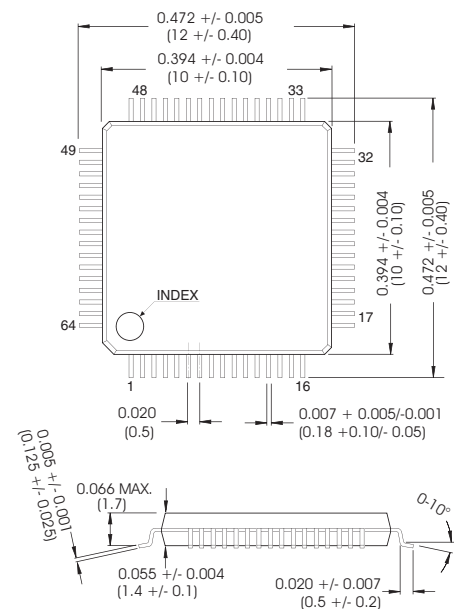

Enlarged View Above

Actual Size

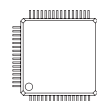

IM2000S PIN ASSIGNMENTS

PIN	NAME	FUNCTION
59	SCLK	Step clock input. A positive going edge on this input will advance the motor one increment (the size of the increment is dependent on the microstep select inputs).
52	RSEL	ROM select input. When low, this input selects the internal sine/cosine ROM. When high, AD0-AD8 are selected for use with an external lookup table.
57	RESET	Reset input. When low, this input will reset the IM2000S (PWM, Enable and Full Bridge outputs will be disabled). When released, the controller will be at its initial state (sine at 0, cosine at peak).
60	DIR	Direction input. This input is used to change the direction of the motor. Physical direction also depends on the connection of the motor windings.
53	CSEL	Clock select input. When low, the SCLK input will be directed to the internal sine/cosine generator independent of the level of the EN input. When high, the SCLK input will be directed to the COUT output when the EN input is low and, conversely, to the internal sine/cosine generator when the EN input is high.
61	EN	Enable input. When low, this input will enable/disable the PWM and full bridge output signals.
62	FSTEP	On fullstep output signal. This active low output indicates when sine & cosine outputs of the IM2000S are positioned on a full step.
63	FAULT	Fault output signal. This active high output indicates when a fault has occurred. It will stay active until the IM2000S is reset.
64	WR	Write input. When the IM2000S is configured in the buss mode, this input is used to latch in the microstep select, enable and direction inputs.
1	MODE	Mode select input. This input is used to configure the IM2000S in a stand-alone or buss mode.
45, 2	PWMA, PWMB	Phase A and Phase B pulse width modulated output signals. These outputs can be used to control the phase currents in common PWM type power sections.
44, 3	SIGNA, SIGNB	Sign of A and sign of B output signals. These outputs indicate the sign of the sine and the sign of the cosine.
43, 4	ENA, ENB	Phase A and Phase B enable output signals. These active high outputs, which work in conjunction with the enable input of PIN 6, can be used to enable/disable the power section of the driver.
38, 39, 41, 42	HRA, LRA, LLA, HLA	Phase A high side and low side full bridge control signals. These outputs can be used to control discrete P-N or N-N full bridge sections or half and full bridge ICs.
5, 6, 8, 9	HLB, LLB, LRB, HRB	Phase B high side and low side full bridge control signals. These outputs can be used to control discrete P-N or N-N full bridge power sections or half and full bridge ICs.
12-19	COS0-COS7	Cosine waveform output signals for Phase B.
28-35	SIN7-SIN0	Sine waveform output signals for Phase A.
47	IHI	Polarity select input for active high or active low high side full bridge control outputs.
46	ILOW	Polarity select input for active high or active low low side full bridge control outputs.
36, 11	VSA, VSB	Phase A and Phase B current sense inputs.
37, 10	OVCA, OVCB	Phase A and Phase B over current/short circuit protection inputs.
20	CURRED	Automatic current reduction output signal. This active high output is used to automatically reduce the driver output current 1 second after the last step clock input.
22, 23	OSCRC, OSCR	Resistor/capacitor inputs for on-board PWM oscillator.
24	OVV	Over voltage protection input.
26	OVTMP	Over temperature protection input.
25, 58	VCC	Supply voltage.
7, 21, 40, 54	GND	Ground.
48-51	MSEL0-MSEL3	Microstep resolution select inputs. These inputs are used to select the number of microsteps per full step. The available resolutions (microsteps/step) are: 2, 4, 5, 8, 10, 16, 25, 32, 50, 64, 125, 128, 250, 256.
12-19	AD0-AD7	Address 0 - Address 7. These outputs are used in conjunction with external lookup tables for user supplied sine and cosine curves.
27	COUT	SCLK output. This output is dependent on the CSEL and EN inputs.
55, 56	CIR0, CIR1	PWM circulation select inputs. These inputs are used to select whether or not the PWM will be in a recirculating or a non-recirculating mode, or an automatic recirculating and non-recirculating mode.

IM2000S ABSOLUTE MAXIMUM RATINGS

Symbol	Parameter	Limits	Unit
V _{DD}	DC Supply Voltage	V _{SS} -0.3 to +7.0	V
V _{IN}	Input Voltage	V _{SS} -0.3 to V _{DD} +0.3	V
V _{OUT}	Output Voltage	V _{SS} -0.3 to V _{DD} +0.3	V
T _{STG}	Storage Temp	-65 to +150	°C

RECOMMENDED OPERATING CONDITIONS

Symbol	Parameter	Min	Typ	Max	Unit
V _{DD}	DC Supply Voltage	4.5	5.0	5.5	V
V _{IN}	Input Voltage	V _{SS}	—	V _{DD}	V
T _{OPR}	Operating Temp	-20	—	85	°C

ELECTRICAL CHARACTERISTICS

AC Electrical Characteristics

Symbol	Parameter	Min	Typical	Unit
t _{RW}	RESET pulse width	200	—	nS
t _S	MSEL, SCLK setup time	—	100	nS
t _{SW}	SCLK pulse width	—	10	nS
t _{WR}	WR pulse width	—	20	nS
t _{WH}	Data hold time after WR	0	—	nS
f _{PWM}	PWM chopping frequency	—	20	KHz
f _{CLK}	SCLK input frequency	—	10	MHz

DC Electrical Characteristics

V_{DD} = +5.0 ±10% T_{OPR} = 25° C

Symbol	Parameter	Conditions	Min	Typ	Max	Unit
V _{IL}	Low level input voltage	—	—	—	0.8	V
V _{IH}	High level input voltage	—	2.0	—	—	V
V _{T+}	Schmitt trigger positive going threshold voltage	V _{DD} = 5.0	—	3.0	—	V
V _{T-}	Schmitt trigger negative going threshold voltage	V _{DD} = 5.0	0.6	—	—	V
V _H	Schmitt trigger hysteresis voltage	V _{DD} = 5.0	0.1	—	—	V
I _{IL}	Low level input current	V _{IN} = V _{SS}	—	—	1.0	mA
I _{IH}	High level input current	V _{IN} = V _{DD}	—	—	1.0	mA
V _{OL}	Low level output voltage	—	—	—	V _{SS} +0.4	V
V _{OH}	High level output voltage	—	V _{DD} -0.4	—	—	V
I _{OL}	Low level output current	—	—	—	-6.0	mA
I _{OH}	High level output current	—	—	—	3.0	mA
I _{CC}	Supply current	—	—	—	30	mA

TYPICAL APPLICATION 48V, 3 Amps (RMS)/Phase Microstepping Driver

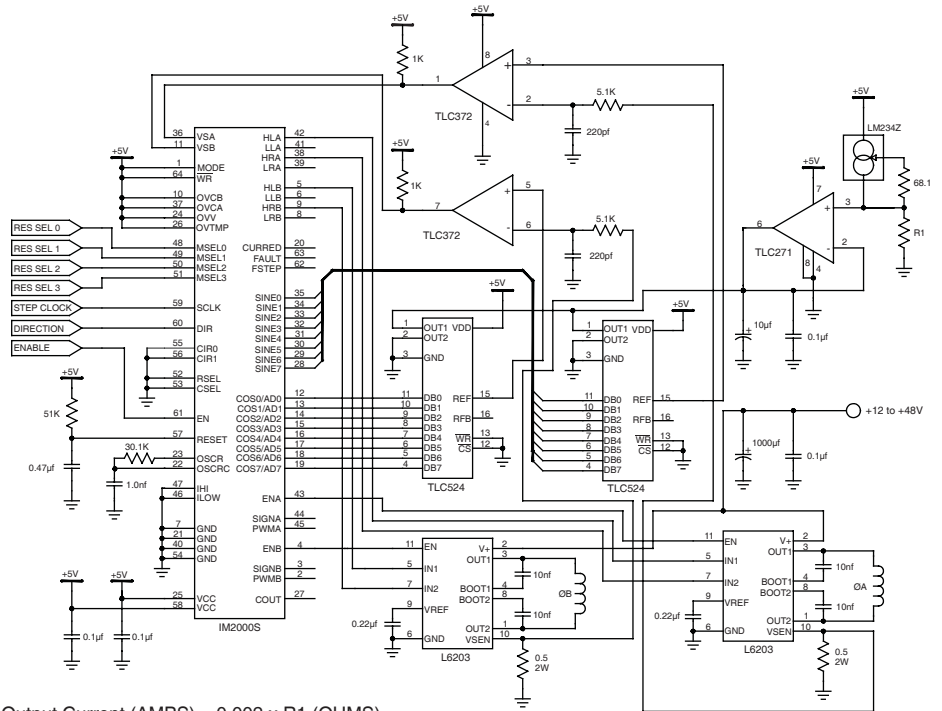

Output Current (AMPS) = 0.002 x R1 (OHMS)

NOTE: Diodes may be needed on phase outputs depending on input voltage and phase currents used.

BLOCK DIAGRAM

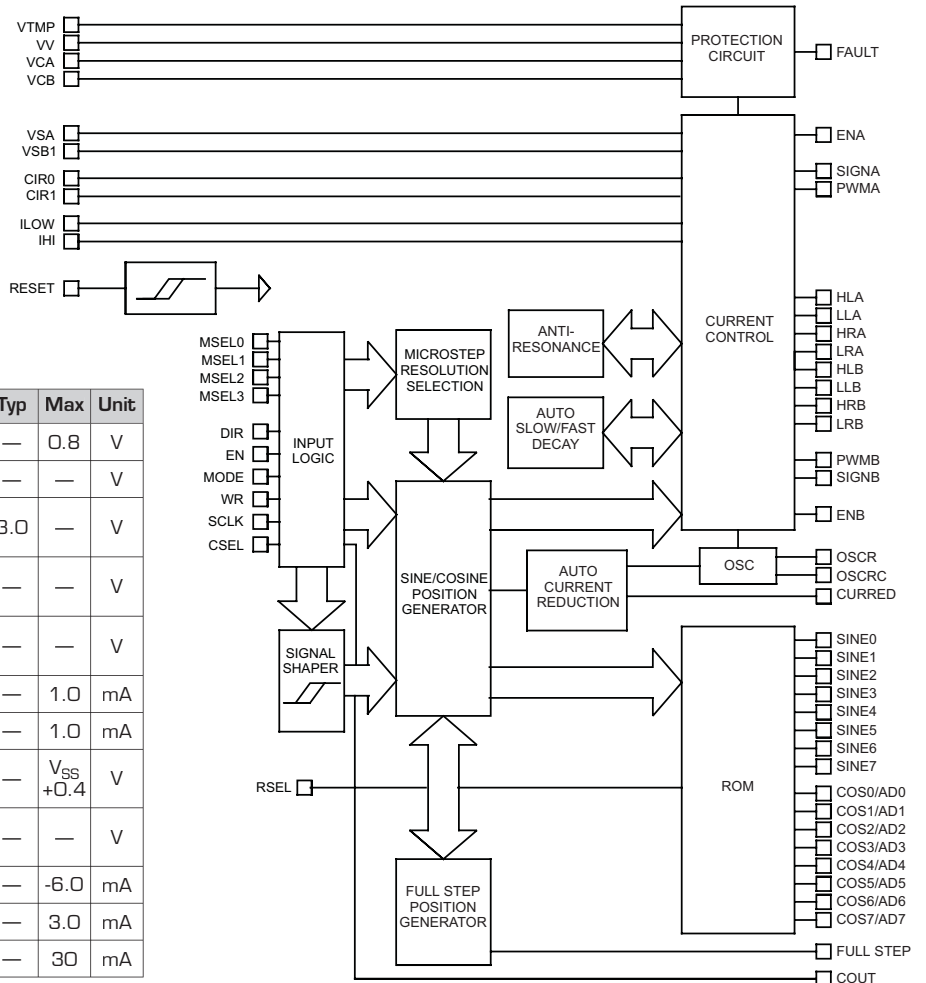

Free Manuals Download Website

<http://myh66.com>

<http://usermanuals.us>

<http://www.somanuals.com>

<http://www.4manuals.cc>

<http://www.manual-lib.com>

<http://www.404manual.com>

<http://www.luxmanual.com>

<http://aubethermostatmanual.com>

Golf course search by state

<http://golfingnear.com>

Email search by domain

<http://emailbydomain.com>

Auto manuals search

<http://auto.somanuals.com>

TV manuals search

<http://tv.somanuals.com>