

IMS™

INTELLIGENT MOTION SYSTEMS, INC.

Excellence in Motion™

IM1007I & IM1007IE

MINIATURE

HIGH PERFORMANCE MICROSTEPPER DRIVER & INDEXER

HARDWARE REFERENCE MANUAL

370 NORTH MAIN ST., MARLBOROUGH, CT 06447, PH. (860) 295-6102, FAX (860) 295-6107

The information in this book has been carefully checked and is believed to be accurate; however, no responsibility is assumed for inaccuracies.

*Intelligent Motion Systems reserves the right to make changes without further notice to any products herein to improve reliability, function or design. Intelligent Motion Systems does not assume any liability arising out of the application or use of any product or circuit described herein; neither does it convey any license under its patent rights nor the rights of others. Intelligent Motion Systems and **IMS** are trademarks of Intelligent Motion Systems, Incorporated.*

Intelligent Motion Systems, Inc. general policy does not recommend the use of its products in life support applications wherein a failure or malfunction of the product may directly threaten life or injury. Per Intelligent Motion Systems Terms and Conditions of Sales, the user of Intelligent Motion Systems products in life support applications assumes all risks of such use and indemnifies Intelligent Motion Systems against all damages.

Table of Contents

Introduction	1
Pin Description	2
Pin Description	3
Absolute Maximum Rating	4
Electrical Specifications	5
Mechanical Specifications	6
Thermal Specifications	7
Over Temperature Protection	7
Output Current	8
Determining Output Current	8
Setting Output Current	9
Encoder Interface	9
Motor	10
Motor Selection	10
Connecting the Motor	11
Connecting Power	12
Optically Isolated Inputs (Limit A, Limit B, Home, Party)	13
General Purpose Inputs	14
Dedicated Inputs	15
Moving Output	15
Fault Protection	16
Party Line Operation	17
Party Line Connection (using RS-232 Option)	17
+5 VDC Output	18
Options/Accessories	18
Application Notes	19
Appendix A: Recommended Cable Configurations	20
Warranty	27

LIST of TABLES

Table 1	ABSOLUTE MAXIMUM RATINGS	4
Table 2	ELECTRICAL SPECIFICATIONS	5
Table 3	THERMAL SPECIFICATIONS	7
Table 4	POWER SUPPLY SPECIFICATIONS	12
Table 5	OPTICALLY ISOLATED INPUTS	13

LIST of FIGURES

Fig. 1	MACHANICAL OUTLINE	6
Fig. 2	ENCODER INTERFACE.....	9
Fig. 3	MOTOR CONNECTIONS	11
Fig. 4	ISOLATED INPUTS	13
Fig. 5	GENERAL PURPOSE INPUTS AND OUTPUTS.....	14
FIG. 6	DEDICATED INPUTS	15
FIG.7	PARTY LINE INTERFACE	17

INTRODUCTION

The IM1007I & IM1007IE with optional Indexer and encode feedback are highly integrated systems in an extremely small package measuring only 3.0" X 5.9" X 1.1". The IM1007I & IM1007IE make use of advanced surface mount and ASIC technology for unmatched performance, reliability, and value.

The IM1007I & IM1007IE's Indexer delivers superior results by intergrating standard hardware with a technology called Variable Resolution Microstep Control. At low shaft speeds, the Indexer produces high resolution microstep positioning for silent, resonance-free operation. As shaft speed increases, the output step resolution is expanded using "on-motor-pole" synchronization. At the completion of a move, the target micro position is trimmed to 1/100 of a step to achieve and maintain precise positioning.

Incorporated into the IM1007I & IM1007IE drivers are circuits that minimize ripple current while maintaining a 20KHz chopping rate. This prevents additional motor heating that is common with drivers requiring higher chopping rates. Now low inductance step motors can be used to improve high speed performance and peak system efficiency

The results of this unique driver/Indexer combination is a cost effective, off the shelf solution, that can provide designers with a powerful and versatile unit that is unmatched in today's industry.

FEATURES

- INTEGRAL INDEXER, DRIVER, & ENCODER FEEDBACK
- EXTREMELY COMPACT 3 X 5.9 X 1.1
- LOW COST
- SHORT CIRCUIT AND OVER TEMPERATURE PROTECTION
- OVER AND UNDER VOLTAGE PROTECTION
- HIGH INPUT VOLTAGE (100V)
- HIGH OUTPUT CURRENT
(7 AMPS RMS, 10 AMPS PEAK)
- ADVANCED SURFACE MOUNT & ASIC TECHNOLOGY
- SINGLE SUPPLY
- FIXED OR VARIABLE STEP RESOLUTION
- 1/100 STEP COMMAND RESOLUTION
- 1/256 STEP MOTOR RESOLUTION
- PROGRAMMABLE ACCEL & DECEL RAMPs
- PROGRAMMABLE MOTOR RUN AND HOLD CURRENTS
- RS-422 PARTY LINE OPERATION
- 2K BYTES OF NON-VOLATILE MEMORY FOR PROGRAM STORAGE
- 6 BUFFERED USER I/O PORTS
- OPTICALLY ISOLATED HOME AND LIMIT SWITCH INPUTS
- DUAL SPEED JOG INPUTS
- GO AND SOFT STOP INPUTS
- OPTIONAL *WINDOWS BASED PROGRAMMING SOFTWARE
- MOTOR SPEEDS TO 6,000 RPMs
- PROGRAMMABLE TRIP POINTS
- OVER 50 MOTION CONTROL COMMANDS

*WINDOWS is a registered trademark of the Microsoft Corp.

PATENTS PENDING

PIN ASSIGNMENTS

Connector P1

[†] PIN #	FUNCTION
(38) (34)	
1 -	NC
2 1	TX -
3 2	RX -
4 3	Jog speed
5 4	Step Clock Out/ Receive (with RS232 option)
6 5	Jog +
7 6	Moving
8 7	Jog -
9 8	Opto Supply Voltage
10 9	Soft stop
11 10	Party
12 11	Go
13 12	Limit B
14 13	Fullstep*
15 14	Home
16 15	Index (with Encoder Option)
17 16	Limit A
18 17	Channel B (with Encoder option)
19 -	Channel B + (with Encoder option)

PIN # FUNCTION

Connector P2

1	NC
2	Fault
3	NC
4	NC
5	Supply Ground
6	+V (Supply Voltage)
7	Phase B
8	Phase B
9	Phase A
10	Phase A

Note: NC = No connection. These pins must be left floating.

*Non buffered signals. Care should be taken when using these outputs.

[†]34 pin standard connector.

38 pin connector for optional differential encoder feedback.

[†] PIN #	FUNCTION
(38) (34)	
20 -	Index + (with Differential Encoder option)
21 18	TX +
22 19	RX +
23 20	Output 3
24 21	Output 1
25 22	Output 2
26 23	Input 1
27 24	Input 3
28 25	Input 2
29 26	Direction out/Transmit (with RS232 option)
30 27	Ground
31 28	NC/Channel B - (with Differential Encoder option)
32 29	+5V Output
33 30	NC/Channel A - (with Differential Encoder option)
34 31	Resolution Select 3
35 32	NC/Index - (with Differential Encoder option)
36 33	Fault *
37 34	Channel A (with Encoder option)
38 -	Channel A + (with Differential Encoder option)

PIN DESCRIPTION

Connector P1

*PIN # PIN NAME

FUNCTION

1	NC	No Connection
2	TX -	RS422 Transmit -, (data out from indexer).
3	RX -	RS422 Receive -, (data in to indexer).
4	Jog Speed	Jog Speed input. low = hi speed, hi(floating) = low speed. Internally pulled up to +5VDC through a 10K resistor.
5	SCLK Out/Receive	Step Clock Output from Indexer / RS 232 data in to indexer (with RS232 option installed).
6	Jog +	Active low Jog input for "+" direction. Internally pulled up to +5vdc through a 10k resistor.
7	Moving	Moving output, low when indexing is in progress. High when not moving.
8	Jog -	Active low Jog input for "-" direction. Internally pulled up to +5vdc through a 10k resistor.
9	Opto Supply	DC bias for input opto couplers. Internal current limiting resistors for +5vdc are supplied. Series resistors must be connected to optically isolated input signals for voltages greater than 5vdc.
10	Soft Stop	Active low input to stop indexing using deceleration ramp. Internally pulled up to +5vdc through a 10k resistor.
11	Party	Optically isolated party mode select pin: 0 = Party, 1(Floating) = Single.
12	GO	Active low level input to execute a program stored in NVM. Program execution begins at location 0 in memory. Internally pulled up to +5vdc through a 10k resistor. Once executing, the GO input is ignored until the program completes or an Abort/Stop is executed.
13	Limit B	Optically isolated, active low limit switch input for "-" direction.
14	Fullstep	Non-buffered output, active for one clock pulse at each on-pole fullstep position.
15	Home	Optically isolated, active low Home switch input
16	Index	Encoder index marker input. Internally pulled up to +5vdc through a 10k resistor.
17	Limit A	Optically isolated, active low limit switch input for "+" direction.
18	Channel B	Encoder channel B input. Internally pulled up to +5vdc through a 10k resistor.
19	Channel B +	Differential Encoder Channel B + input. (with Differential Encoder Option Installed).
20	Index +	Differential Encoder Index Marker + input. (with Differential Encoder Option Installed).
21	TX +	RS422 Transmit +, (data out from indexer).
22	RX +	RS422 Receive +, (data in to indexer).
23	Output 3	User controlled output #3. This is an open collector output with an internal 10k pullup resistor to +5VDC.
24	Output 1	User controlled output #1. This is an open collector output with an internal 10k pullup resistor +5VDC.
25	Output 2	User controlled output #2. This is an open collector output with an internal 10k pullup resistor +5VDC.
26	Input 1	User controlled input #1. Internally pulled up to +5vdc through a 10K resistor.
27	Input 3	User controlled input #3. Internally pulled up to +5vdc through a 10K resistor.
28	Input 2	User controlled input #2. Internally pulled up to +5vdc through a 10K resistor.
29	DIR Out / Transmit	Direction Output from Indexer / RS 232 data out from indexer (with RS232 option installed).
30	Ground	Logic Ground (internally connected to the Supply Ground).
31	NC/Channel B-	No Connection / Differential encoder Channel B- input. (with Differential Encoder Option Installed).
32	+5VDC	Logic supply output for Encoder power.
33	NC/Channel A-	No Connection / Differential Encoder Channel A- input. (with Differential Encoder Option Installed).
34	MSEL3	Resolution Selection 3 input. Internally pulled down via a 1.5K resistor.
35	NC/Index -	No Connection / Differential Encoder Index Marker - input (with Differential Encoder Option Installed).
36	Fault	Non-buffered output indicating driver fault condition. This output will be active High when the driver detects an internal fault such as overcurrent or phase short. A reset or power down is required to clear the fault condition.
37	Channel A	Encoder Channel A input. Internally pulled up to +5vdc through a 10k resistor.
38	Channel A +	Encoder Channel A + input. (with Differential Encoder Option Installed).

Connector P2

* 34 PIN STANDARD CONNECTOR

38 PIN CONNECTOR FOR OPTIONAL DIFFERENTIAL ENCODER FEEDBACK

PIN #	PIN NAME	FUNCTION
1	NC	No Connection
2	Fault	High voltage open collector output indicating driver fault condition. High when driver detects internal fault. Reset or power down to clear the fault condition.
3,4	NC	No Connection
5	Ground	Supply Voltage Ground

PIN #	PIN NAME	FUNCTION
6	+V	Supply Voltage
7	Phase B	Phase B motor connection
8	Phase B	Phase B motor connection
9	Phase A	Phase A motor connection
10	Phase A	Phase A motor connection

ABSOLUTE MAXIMUM RATING

Table 1

INPUT VOLTAGE.....	+ 24 TO + 100 VDC
OUTPUT CURRENT.....	12 AMPS PEAK
PLATE TEMPERATURE.....	+ 70 C*
STORAGE TEMPERATURE.....	-40 TO + 125 C
LOGIC INPUT CURRENT (ISOLATED INPUTS).....	15 mA
LOGIC OUTPUT CURRENT	25mA
POWER DISSIPATION (Logic Outputs)	450 mW
INPUT VOLTAGE (Dedicated Logic Inputs)	-1.5 to + 18 V

* ADDITIONAL COOLING MAY BE REQUIRED TO LIMIT PLATE TEMPERATURE TO 70 C.

NOTE: An optional thermal pad is available for the IM1007I & IM1007IE.

ELECTRICAL SPECIFICATIONS

Table 2

TA = 25 C, V + = 80 V

	TEST CONDITION	MIN	TYP	MAX	UNITS
INPUT VOLTAGE		24		80	V
PHASE OUTPUT CURRENT	RMS	2.0		7	A
PHASE OUTPUT CURRENT	PEAK			10	A
QUIESCENT CURRENT	OUTPUTS FLOATING		100		mA
ACTIVE POWER DISSIPATION	IOUT = 7 AMPS RMS			19	W
INPUT FORWARD CURRENT	ISOLATED INPUTS		7.0	15	mA
INPUT FORWARD VOLTAGE	ISOLATED INPUTS		1.5	1.7	V
INPUT REVERSE BREAKDOWN VOLTAGE	ISOLATED INPUTS	5			V
INPUT VOLTAGE	DEDICATED LOGIC INPUTS	0		15	V
INPUT VOLTAGE	GENERAL PURPOSE INPUTS	0		5	V
OUTPUT CURRENT	FAULT OUTPUT			25	mA
COLLECTOR-EMITTER VOLTAGE	FAULT OUTPUT			140	V
COLLECTOR-EMITTER SATURATION VOLTAGE	FAULT OUTPUT			0.2	V

Ics = 25 mA DC

NOTE: The aluminum bottom plate is electrically isolated

THERMAL SPECIFICATIONS

Table 3

OPERATING TEMPERATURE.....	0 TO +50 C
STORAGE TEMPERATURE	-40 TO +125 C
* PLATE TEMPERATURE (MAX)	+70 C

* ADDITIONAL COOLING MAY BE REQUIRED TO LIMIT PLATE TEMPERATURE TO 70 C.

NOTE: An optional thermal pad is available for the IM1007I & IM1007IE.

OVER TEMPERATURE PROTECTION

The IM1007I & IM1007IE microstepping is a power device and is designed to protect itself from over heating. It does this by monitoring the surface temperature of the drive plate and will automatically shut down if the temperature reaches 60 C (152 F).

To prevent nuisance shut downs proper heatsinking is required to limit the temperature at the drive plate. An optional heatsink is available for those applications where the mounting surface is inadequate.

A thermal grease or thermal pad should be used between the drive plate and the mounting surface of the heat-sink. The fins of the heatsink should be mounted vertically with at least 3" of space below and above the heat-sink for efficient cooling.

In some applications fan cooling will be required to maintain the plate temperature below the 60 C shut down temperature.

It is not recommended that the driver be installed in a sealed enclosure where there is no exchange of outside ambient air. The heat buildup (even with an internal fan) would cause the driver to shut down well below its full output capability.

OUTPUT CURRENT

DETERMINING OUTPUT CURRENT

The OUTPUT CURRENT for motor used for MICROSTEPPING is determined differently from that of a HALF/FULL STEP driver.

In the IM1007I & IM1007IE, a sine/cosine output function is used in rotating the motor. Therefore the output current of the specified motor is equal to the RMS current of the driver.

The DIGITAL POTENTIOMETER used to set the output current of the IM1007I & IM1007IE sets the PEAK output current of the sine/cosine waves. Therefore the specified motor current (which is the RMS value) should be multiplied by 1.4 in order to determine the PEAK value to which the IM1007I & IM1007IE will be set.

EXAMPLE:

IMS motor number HM200-2232-190 A8 wired in parallel has a specified PHASE CURRENT of 2.7 amps.

Therefore $2.7 \times 1.4 = 3.78$ amps

Note: Stepper motors can be configured as 4, 6, or 8 leads. Each configuration requires different currents. shown below are the different lead configurations and the procedures to determine their output current

4 Lead Motors: Use specified motor current to determine the current adjustment resistor value.

6 Lead Motors: 1) When configuring a 6 lead motor in a half coil configuration (i.e. connected from one end of the coil to the center tap (higher speed configuration)) use the specified per phase (or unipolar) current rating to determine the current adjustment resistor value.

2) When configuring the motor so the entire coil is used (i.e. connected from end to end with the center tap floating (higher torque configuration)) multiply the per phase (or unipolar) current rating by 0.7. Use this result to determine the current adjustment resistor value.

8 Lead Motors: **SERIES CONNECTION** When configuring the motor windings in series, multiply the per phase (or unipolar) current rating by 0.7. Use this result to determine the current adjustment resistor value.

PARALLEL CONNECTION When configuring the motor windings in parallel, multiply the per phase (or unipolar) current rating by 1.4. Use this result to determine the current adjustment resistor value.

Note: After the current has been determined, according to the motor connections above, follow the procedure Determining Output Current above to find the PEAK current value.

WARNING! Although stepping motors will run hot when configured correctly, damage may occur to the motor if a higher than specified current is used. Most specified motor currents are maximum values. Care should be taken when exceeding these ratings.

SETTING OUTPUT CURRENT

The OUTPUT CURRENT for both Run and Hold are set using an on board digital potentiometer. Refer to the software reference manual for further information.

ENCODER INTERFACE

An encoder with TTL level outputs is required to interface with the IM1007IE. On board 10K pullups are provided so that encoders with open collectors outputs may be used. Figure 2 shows a typical encoder interface.

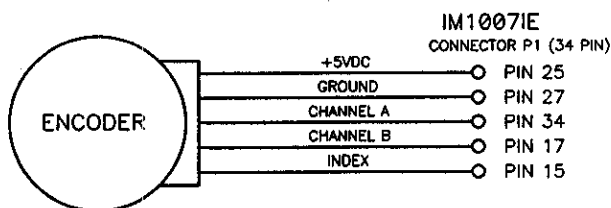

Fig. 2

Figure 2A shows a typical encoder interface for the IM1007IE-DE with differential encoder inputs.

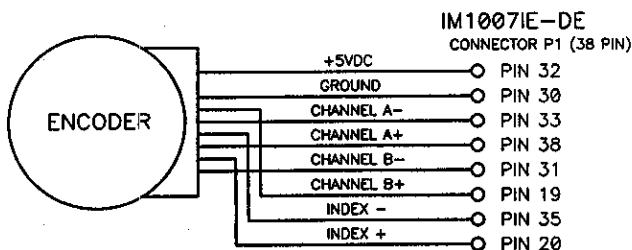

Fig. 2A

MOTOR SELECTION

The IM1007I & IM1007IE are Bipolar drivers which work equally well with both Bipolar and Unipolar motors, (i.e. 8 and 4 lead motors and 6 lead center tapped motors (see section 9.2, Connecting the Motor)).

To maintain a given set motor current, the IM1007I & IM1007IE chops the voltage using a constant chopping frequency and a varying duty cycle. Duty cycles that exceed 50% can cause unstable chopping. This characteristic is directly related to the motor's winding resistance. To avoid this situation, it is necessary to choose a motor with a low winding resistance. The lower the winding resistance (hence lower winding inductance) the higher the step rate.

Since the IM1007I & IM1007IE are constant current sources, it is not necessary to use a motor that is rated at the same voltage as the supply voltage. What is important is that the IM1007I & IM1007IE are set to the motor's rated current.

The higher the voltage used the faster the current can flow through the motor coils. This in turn means a higher step rate. Care should be taken not to exceed the maximum voltage of the driver.

Therefore in choosing a motor for a system design, the best performance for a specified torque is a motor with the lowest possible winding resistance used in conjunction with the highest possible driver voltage.

CONNECTING THE MOTOR

Phase A of the Stepping Motor is connected between pins 9 and 10 on connector P2. Phase B of the Stepping Motor is connected between pins 7 and 8 on connector P2. The following drawings illustrate the connection of 4, 6, and 8 Lead Stepping Motors to the IM1007I & IM1007IE Drivers.

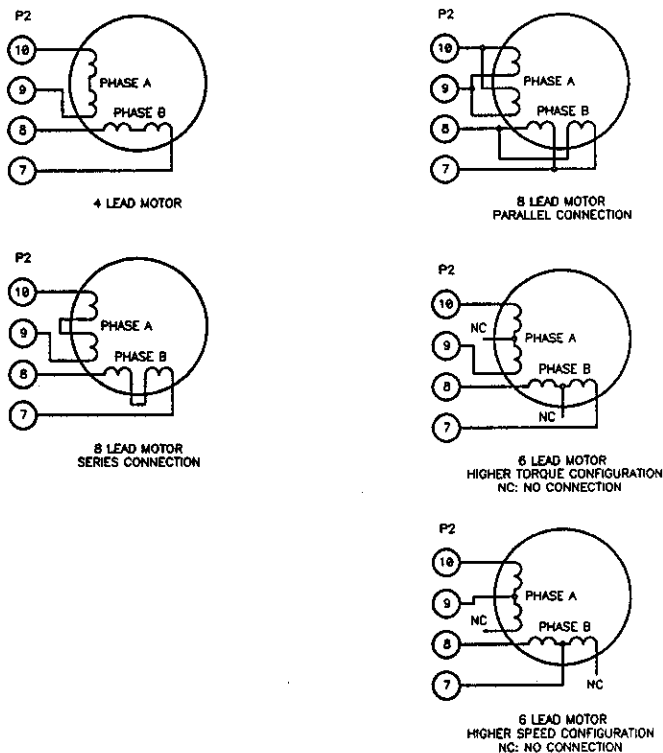

Fig. 3

NOTE: The physical direction of the motor with respect to the direction Input will depend on the connection of the motor windings. To reverse the direction of the motor with respect to the direction input, switch the wires on phase A or phase B outputs. **Warning!! Do not connect or disconnect motor leads while power is applied!!**

CONNECTING POWER

Pins 5 and 6 on connector P2 are used to connect the DC Power Supply to the IM1007I & IM1007IE. Wire size used to connect the power source to the driver should be at least 16 gage. Heavier wire should be used for longer distances between the power supply and the driver. The power supply requirements are as follows:

Table 4

POWER SUPPLY SPECIFICATIONS

Recommended Type:.....	Unregulated DC.
Ripple Voltage:	$\pm 10\%$
Output Voltage:	+24 to +80v DC
* Output Current.....	3 Amps (TYPICAL)

NOTE: Switching Power Supplies and regulated linears with overcurrent protection are not recommended because of their inability to handle surge currents.

If multiple drivers are to be run off of one power supply each drive should have separate power and ground wires that connect directly to the output capacitor of the power supply.

Warning! When using an unregulated power supply, care should be taken to ensure that the output voltage DOES NOT exceed the maximum driver input voltage because of line voltage fluctuations. It is recommended that a input line filter be used on the power supply to limit voltage spikes to the driver.

* THE OUTPUT CURRENT NEEDED IS DEPENDENT ON THE SUPPLY VOLTAGE, MOTOR SELECTION, AND LOAD.

Warning!! Do not connect or disconnect motor leads while power is applied!!

OPTICALLY ISOLATED INPUTS (Limit A, Limit B, Home, Party)

The following inputs to the IM1007I & IM1007IE are Optically Isolated.

Table 5

Connector P1	34 PIN 38 PIN
Limit A	Pin 16; 17
Limit B	Pin 12; 13
Home.....	Pin 14; 15
Party.....	Pin 10; 11

For functional use of these inputs refer to the software reference manual.

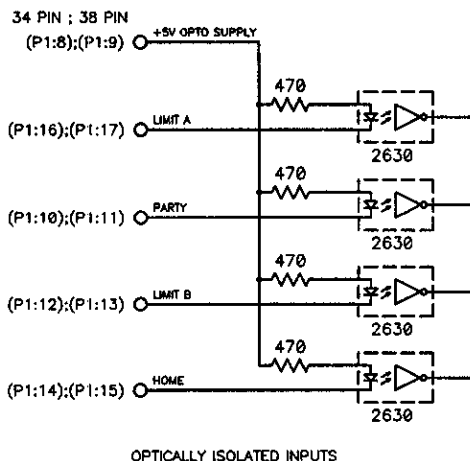

Fig. 4

The isolated inputs may be powered by a DC voltage other than +5 VDC. In doing so, care should be taken to limit this current, an external resistor should be placed in series with the input pins (10,12,14,16). The value of the resistor should be calculated such that the input current is approximately equal to the value listed in the Electrical Specifications in Table 2.

WARNING! If using a voltage other than +5VDC, the current through the optocoupler must NOT exceed the maximum limit.

GENERAL PURPOSE INPUTS AND OUTPUTS

The IM1007I & IM1007IE contain 3 general purpose inputs and 3 general purpose outputs. The inputs are TTL compatible and are pulled up via a 10K resistor to +5V on the input. (see Fig below)

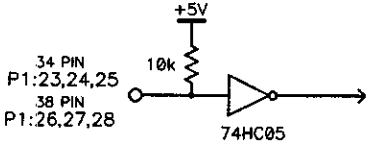

The outputs are TTL compatible open collector type and are also pulled to +5V via a 10K resistor. (see Fig. below).

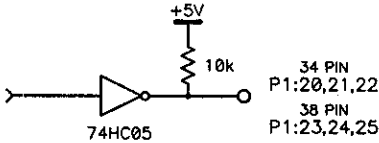

Fig. 5

For functional use of these inputs and outputs refer to the Software Reference Manual.

DEDICATED INPUTS

The IM1007I & IM1007IE contain 5 dedicated inputs: Go, Soft Stop, Jog +, Jog -, and Jog speed. They are capable of handling logic level inputs that range from +5 VDC to +15 VDC. The inputs are pulled up to +5V via a 10K resistor on the Inputs (see Fig below).

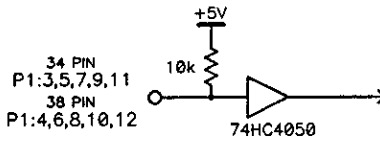

Fig. 6

For functional use of these inputs refer to the Software Reference Manual.

MOVING OUTPUT

The moving output is used to indicate when the motor is in motion. When LOW, the indexer is stepping the motor (in either direction). When HIGH the motor is at rest.

The Moving line is buffered as shown below.

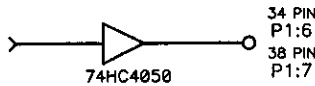

FAULT PROTECTION

The IM1007I & IM1007IE are internally protected against over temperature, over and under voltage, and short circuits.

The over temperature set point is between 60 and 70 C. Care should be taken when choosing a heatsink so that there is good thermal flow, otherwise hot spots may occur in the IM1007I & IM1007IE which will reduce the effectiveness of the thermal protection.

The short circuit protection consist of PHASE to PHASE, PHASE to GROUND, and +V to PHASE.

In the condition where the DC voltage to the driver drops below approximately 23 volts, the driver's output stage will be disabled. When the driver's DC voltage rises back above 24 volts, the driver will automatically re-enable the outputs (if previously enabled).

In the condition where the DC voltage to the driver exceeds approximately 90 volts, the driver will execute a fault.

If any fault is detected by the IM1007I & IM1007IE, the outputs will be disabled and can not be re-enabled without resetting or powering down the driver (does not include under voltage). At the same time the open collector FAULT output is turned on.

This Fault output is non-isolated and has the ability to sustain the maximum driver voltage. It is capable of sinking up to 25mA which can be used to drive a small relay or LED.

The FAULT output on connector P1, pin 33 is an active HIGH TTL compatible signal. This signal is non buffered, and care should be taken when using this output.

PARTY LINE OPERATION

The IM1007I & IM1007IE can operate as stand alone units or they can be configured to communicate over a party line which responds to a unique address. Up to 32 units can be linked together on one line.

To communicate over the party line, the unit must first be assigned an address. This assignment takes place via the Serial Communication line with the IM1007I & IM1007IE in a Stand Alone mode (i.e. P1 pin 10 floating).

After an address is assigned, the IM1007I & IM1007IE can be tied to the Multi Unit System by enabling the Party Line input (P1 pin 10).

Figure 7 shows a typical Party Line Connection.

For more information on Interfacing to the Party Line input, refer to Section 11.

For more information on Assigning Addresses, refer to the Software Reference Manual.

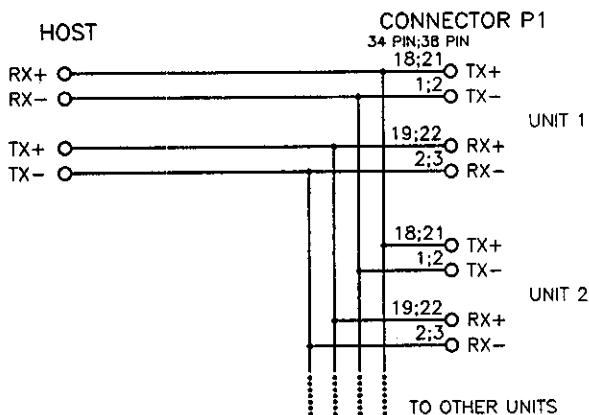

Fig. 7

PARTY LINE CONNECTION USING RS-232 OPTION

When running in Party Line Mode with the RS-232 option, the host communicates with the unit via RS-232 by using the 34 pin (P1) connector. This unit would then be connected to the other units in the system operating in the party line mode such that all of the TX+ 's would be tied together, as well as the TX-, RX+, and RX-, respectively. The address assignment and the communications would be as described in the Party Line Operations above.

+ 5V DC OUTPUT

The +5V DC output on the IM10071 & IM10071E is intended to drive the encoder feedback device ONLY. This output should NOT be used as a general purpose power supply. When using this supply care should be taken not to inject noise back into the driver. An increase in case temperature may also occur due to the increase in current through the linear regulator.

OPTIONS/ACCESSORIES

Description	Part Number
Thermal Pad	TN - 1000
34 pin Breakout Box	BB - 34
RS232 to RS422 converter	CV - 3222
GUI Controller Software (Requires *Windows V3.0 or greater)	QuickSTEP™

* Windows is a registered trademark of the Microsoft Corp.

APPLICATION NOTES

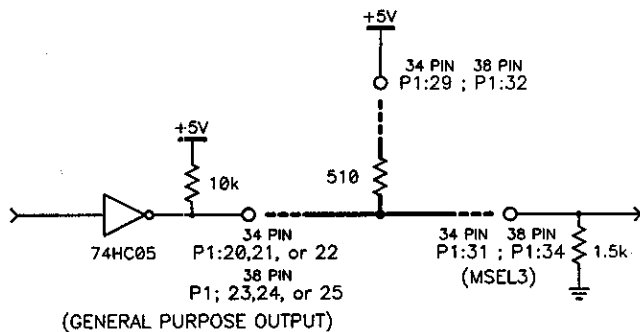

USING A GENERAL PURPOSE OUTPUT TO ENABLE
THE SELECTION OF DECIMAL RESOLUTIONS

RESOLUTION (D COMMAND)	STEP SIZE (MICROSTEPS/STEP)
0ILLEGAL STATE
1 5
2 10
3 25
4 50
5 125
6 250
7ILLEGAL STATE
8ILLEGAL STATE

Warning! Decimal resolutions can only be used in fixed resolution mode. Refer to the "D" command in the Software Reference Manual for further information.

APPENDIX A

Recommended Cable Configurations: DC Supply to IMS Driver

Cable length, wire gauge and power conditioning devices play a major role in the performance of your IMS Driver and Motor.

NOTE: The length of the DC power supply cable to the IMS Driver should not exceed 50 feet.

Example A demonstrates the recommended cable configuration for DC power supply cabling under 50 feet long. If cabling of 50 feet or longer is required, the additional length may be gained by adding an AC power supply cable (see Examples B & C).

Correct AWG wire size is determined by the current requirement plus cable length. Please see the IMS Driver Supply Cable AWG Table in this Appendix.

Example A - Cabling Under 50 Feet, DC Power

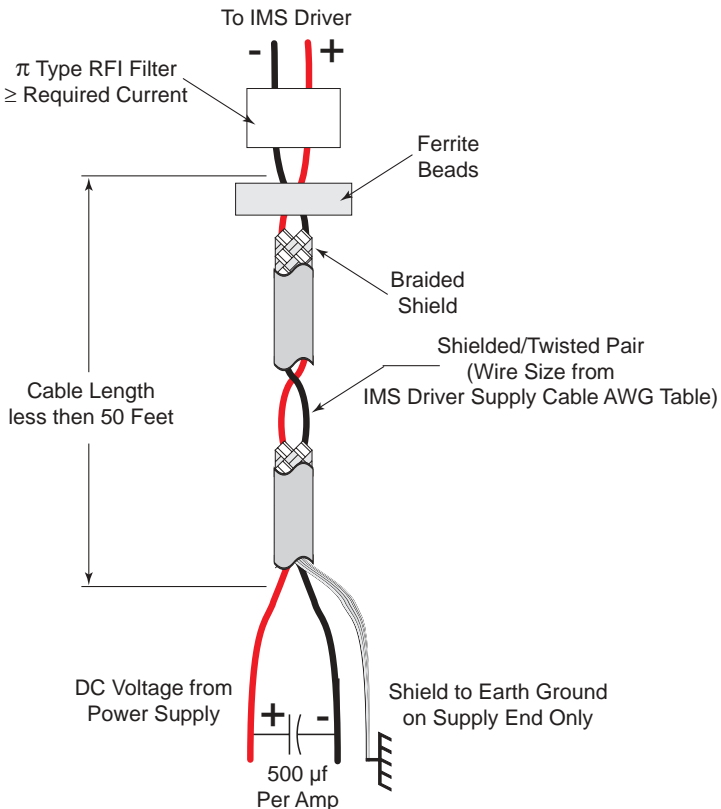

Example B - Cabling 50 Feet or Greater,
AC Power to Full Wave Bridge

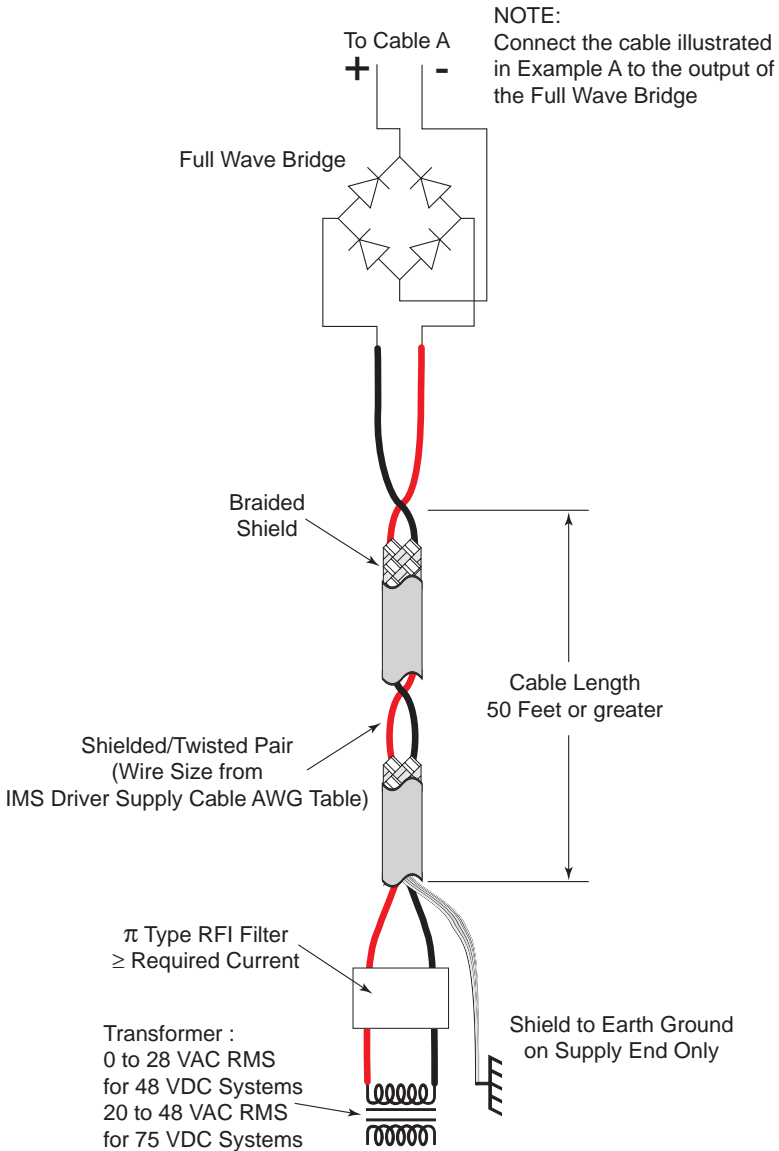

Example C - Cabling 50 Feet or Greater, AC Power to Power Supply

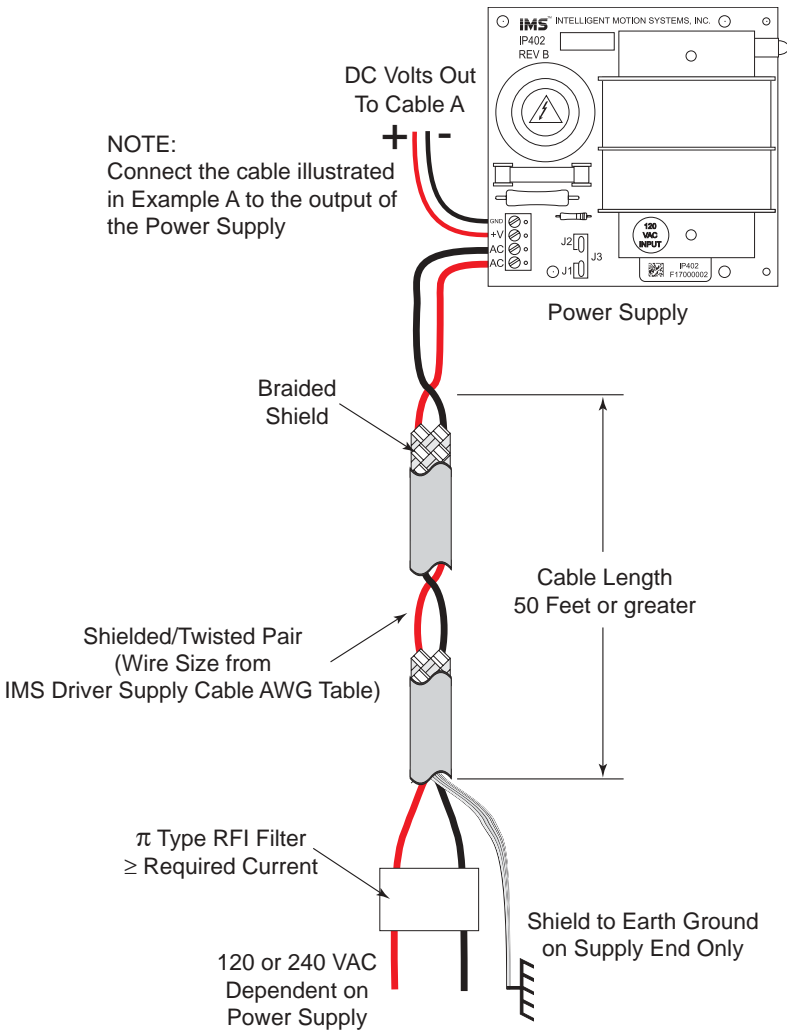

N

NOTE: These recommendations will provide optimal protection against EMI and RFI. The actual cable type, wire gauge, shield type and filtering devices used are dependent on the customer's application and system.

IMS Driver Supply Cable AWG Table					
1 Ampere (Peak)					
Length (Feet)	10	25	50*	75*	100*
Minimum AWG	20	20	18	18	16
2 Amperes (Peak)					
Length (Feet)	10	25	50*	75*	100*
Minimum AWG	20	18	16	14	14
3 Amperes (Peak)					
Length (Feet)	10	25	50*	75*	100*
Minimum AWG	18	16	14	12	12
4 Amperes (Peak)					
Length (Feet)	10	25	50*	75*	100*
Minimum AWG	18	16	14	12	12
* Use the alternative methods illustrated in Examples A and B when the cable length is \geq 50 feet. Also, use the same current rating when the alternate AC power is used.					

Driver Supply Cable Wire Size

N

NOTE: Always use Shielded/Twisted Pairs for the IMS Driver DC Supply Cable, the AC Supply Cable and the IMS Driver to Motor Cable.

Recommended Cable Configurations: IMS Driver to Motor

Cable length, wire gauge and power conditioning devices play a major role in the performance of your IMS Driver and Motor.

NOTE: The length of the DC power supply cable between the IMS Driver and the Motor should not exceed 50 feet.

Example A demonstrates the recommended cable configuration for the IMS Driver to Motor cabling under 50 Feet long. If cabling of 50 feet or longer is required, the additional length can be gained with the cable configuration in Example B.

Correct AWG wire size is determined by the current requirement plus cable length. Please see the IMS Driver to Motor Cable AWG Table in this Appendix.

Example A - Cabling Under 50 Feet,
IMS Driver to Motor

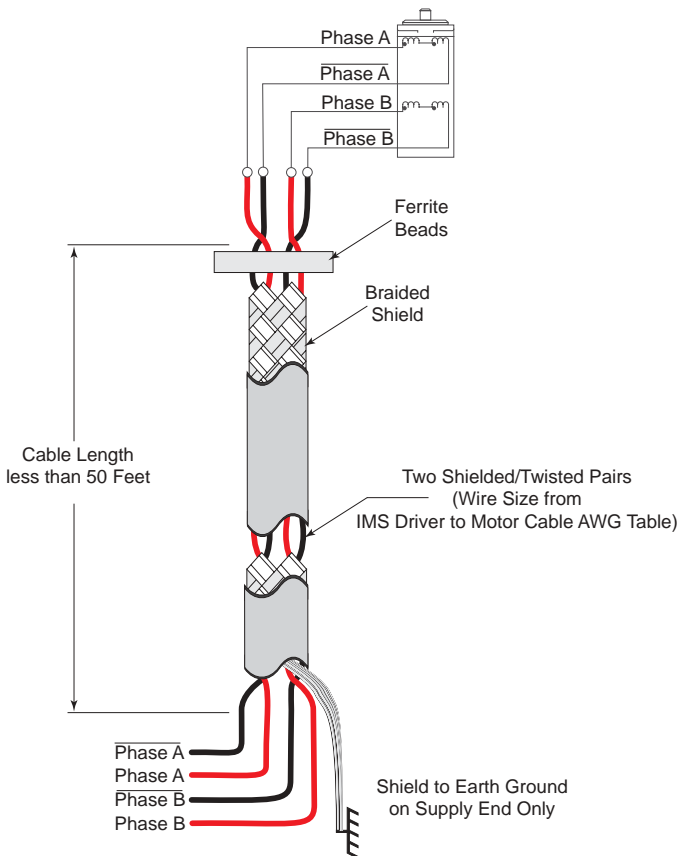

Example B - Cabling 50 Feet or Greater,
IMS Driver to Motor

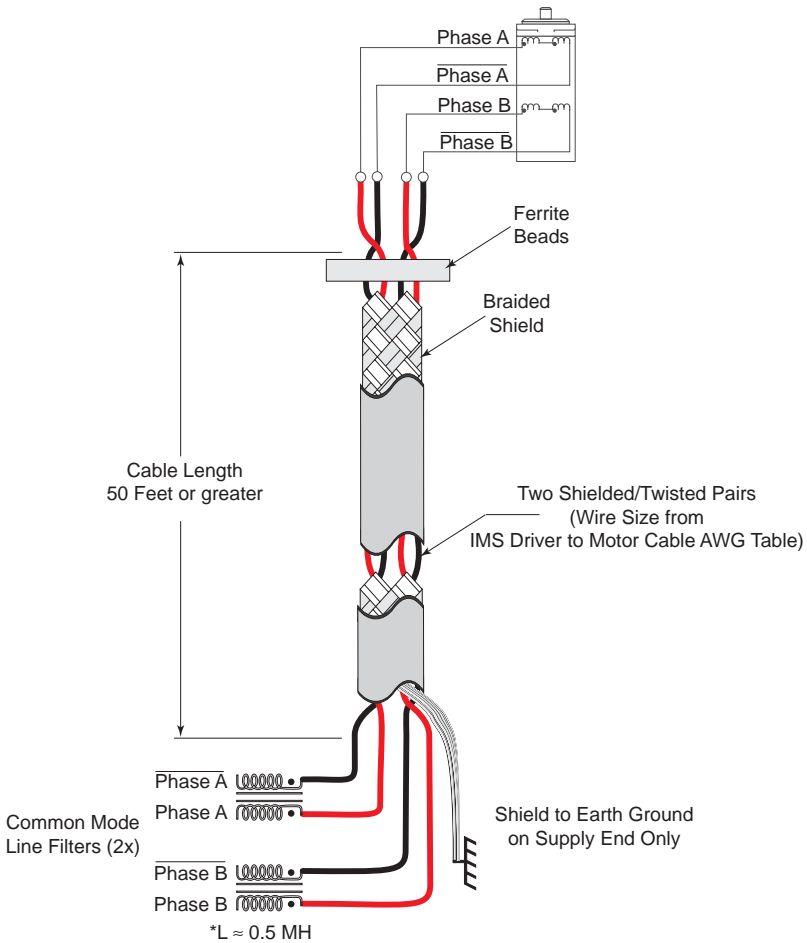

* 0.5 MH is a typical starting point for the Common Mode Line Filters. By increasing or decreasing the value of L you can set the drain current to a minimum to meet your requirements.

IMS Driver to Motor Cable AWG Table											
1 Ampere (Peak)						5 Amperes (Peak)					
Length (Feet)	10	25	50*	75*	100*	Length (Feet)	10	25	50*	75*	100*
Minimum AWG	20	20	18	18	16	Minimum AWG	16	16	14	12	12
2 Amperes (Peak)						6 Amperes (Peak)					
Length (Feet)	10	25	50*	75*	100*	Length (Feet)	10	25	50*	75*	100*
Minimum AWG	20	18	16	14	14	Minimum AWG	14	14	14	12	12
3 Amperes (Peak)						7 Amperes (Peak)					
Length (Feet)	10	25	50*	75*	100*	Length (Feet)	10	25	50*	75*	100*
Minimum AWG	18	16	14	12	12	Minimum AWG	12	12	12	12	12
4 Amperes (Peak)						* Use the alternate method illustrated in Example B when cable length is ≥ 50 feet.					
Length (Feet)	10	25	50*	75*	100*						
Minimum AWG	18	16	14	12	12						

Driver to Motor Supply Cable Wire Size

N **NOTE:** These recommendations will provide optimal protection against EMI and RFI. The actual cable type, wire gauge, shield type and filtering devices used are dependent on the customer's application and system.

N **NOTE:** Always use Shielded/Twisted Pairs for the IMS Driver DC Supply Cable, the AC Supply Cable and the IMS Driver to Motor Cable.

WARRANTY

TWENTY-FOUR (24) MONTH LIMITED WARRANTY

Intelligent Motion Systems, Inc. ("IMS"), warrants only to the purchaser of the Product from IMS (the "Customer") that the product purchased from IMS (the "Product") will be free from defects in materials and workmanship under the normal use and service for which the Product was designed for a period of 24 months from the date of purchase of the Product by the Customer. Customer's exclusive remedy under this Limited Warranty shall be the repair or replacement, at Company's sole option, of the Product, or any part of the Product, determined by IMS to be defective. In order to exercise its warranty rights, Customer must notify Company in accordance with the instructions described under the heading "Obtaining Warranty Service."

This Limited Warranty does not extend to any Product damaged by reason of alteration, accident, abuse, neglect or misuse or improper or inadequate handling; improper or inadequate wiring utilized or installed in connection with the Product; installation, operation or use of the Product not made in strict accordance with the specifications and written instructions provided by IMS; use of the Product for any purpose other than those for which it was designed; ordinary wear and tear; disasters or Acts of God; unauthorized attachments, alterations or modifications to the Product; the misuse or failure of any item or equipment connected to the Product not supplied by IMS; improper maintenance or repair of the Product; or any other reason or event not caused by IMS.

IMS HEREBY DISCLAIMS ALL OTHER WARRANTIES, WHETHER WRITTEN OR ORAL, EXPRESS OR IMPLIED BY LAW OR OTHERWISE, INCLUDING WITHOUT LIMITATION, **ANY WARRANTIES OF MERCHANTABILITY OR FITNESS FOR ANY PARTICULAR PURPOSE**. CUSTOMER'S SOLE REMEDY FOR ANY DEFECTIVE PRODUCT WILL BE AS STATED ABOVE, AND IN NO EVENT WILL THE IMS BE LIABLE FOR INCIDENTAL, CONSEQUENTIAL, SPECIAL OR INDIRECT DAMAGES IN CONNECTION WITH THE PRODUCT.

This Limited Warranty shall be void if the Customer fails to comply with all of the terms set forth in this Limited Warranty. This Limited Warranty is the sole warranty offered by IMS with respect to the Product. IMS does not assume any other liability in connection with the sale of the Product. No representative of IMS is authorized to extend this Limited Warranty or to change it in any manner whatsoever. No warranty applies to any party other than the original Customer.

IMS and its directors, officers, employees, subsidiaries and affiliates shall not be liable for any damages arising from any loss of equipment, loss or distortion of data, loss of time, loss or destruction of software or other property, loss of production or profits, overhead costs, claims of third parties, labor or materials, penalties or liquidated damages or punitive damages, whatsoever, whether based upon breach of warranty, breach of contract, negligence, strict liability or any other legal theory, or other losses or expenses incurred by the Customer or any third party.

OBTAINING WARRANTY SERVICE

Warranty service may be obtained by a distributor, if the Product was purchased from IMS by a distributor, or by the Customer directly from IMS, if the Product was purchased directly from IMS. Prior to returning the Product for service, a Returned Material Authorization (RMA) number must be obtained. Complete the form at <http://www.imshome.com/rma.html> after which an RMA Authorization Form with RMA number will then be faxed to you. Any questions, contact IMS Customer Service (860) 295-6102.

Include a copy of the RMA Authorization Form, contact name and address, and any additional notes regarding the Product failure with shipment. Return Product in its original packaging, or packaged so it is protected against electrostatic discharge or physical damage in transit. The RMA number MUST appear on the box or packing slip. Send Product to: Intelligent Motion Systems, Inc., 370 N. Main Street, Marlborough, CT 06447.

Customer shall prepay shipping charges for Products returned to IMS for warranty service and IMS shall pay for return of Products to Customer by ground transportation. However, Customer shall pay all shipping charges, duties and taxes for Products returned to IMS from outside the United States.

Free Manuals Download Website

<http://myh66.com>

<http://usermanuals.us>

<http://www.somanuals.com>

<http://www.4manuals.cc>

<http://www.manual-lib.com>

<http://www.404manual.com>

<http://www.luxmanual.com>

<http://aubethermostatmanual.com>

Golf course search by state

<http://golfingnear.com>

Email search by domain

<http://emailbydomain.com>

Auto manuals search

<http://auto.somanuals.com>

TV manuals search

<http://tv.somanuals.com>