

The Intermec logo, featuring the word "Intermec" in a bold, blue, sans-serif font with a stylized blue and white graphic element to the right.

User's Guide



EasyCoder PD4 Bar Code Label Printer

Intermec Technologies Corporation

Corporate Headquarters
6001 36th Ave. W.
Everett, WA 98203
U.S.A.

www.intermec.com

The information contained herein is proprietary and is provided solely for the purpose of allowing customers to operate and service Intermec-manufactured equipment and is not to be released, reproduced, or used for any other purpose without written permission of Intermec.

Information and specifications contained in this document are subject to change without prior notice and do not represent a commitment on the part of Intermec Technologies Corporation.

© 2005 by Intermec Technologies Corporation. All rights reserved.

The word Intermec, the Intermec logo, Norand, ArciTech, CrossBar, Data Collection Browser, dcBrowser, Duratherm, EasyCoder, EasyLAN, Enterprise Wireless LAN, EZBuilder, Fingerprint, i-gistics, INCA (under license), InterDriver, Intermec Printer Network Manager, IRL, JANUS, LabelShop, Mobile Framework, MobileLAN, Nor*Ware, Pen*Key, Precision Print, PrintSet, RoutePower, TE 2000, Trakker Antares, UAP, Universal Access Point, and Virtual Wedge are either trademarks or registered trademarks of Intermec Technologies Corporation.

Throughout this manual, trademarked names may be used. Rather than put a trademark (™ or ®) symbol in every occurrence of a trademarked name, we state that we are using the names only in an editorial fashion, and to the benefit of the trademark owner, with no intention of infringement.

There are U.S. and foreign patents pending.

The name Centronics is wholly owned by GENICOM Corporation.
Windows is a trademark of Microsoft Corporation.

FCC Notice (United States of America)

WARNING

This equipment generates, uses, and can radiate radio frequency energy and if not installed and used in accordance with the instructions manual, may cause interference to radio communications. It has been tested and found to comply with the limits for a Class A computing device pursuant to Subpart J of Part 15 of FCC Rules, which are designed to provide reasonable protection against such interference when operated in a commercial environment. Operation of this equipment in a residential area is likely to cause interference in which case the user at his own expense will be required to take whatever measures may be required to correct the interference.

EMS and EMI Compliance Statement

This equipment has been tested and passed with the requirements relating to electromagnetic compatibility based on the standards EN50081-1 (EN55022 CLASS A) and EN61000-4-2/-3/-4/-5/-6/-8/-11 (IEC Teil 2,3,4). The equipment also tested and passed in accordance with the European Standard EN55022 for the both Radiated and Conducted emissions limits.

Contents

Before You Begin.....	viii
Safety Summary.....	viii
Safety Icons	ix
Global Services and Support	x
Warranty Information.....	x
Web Support	x
Telephone Support	x
Related Documents	x

1 Introduction

Description of EasyCoder PD4.....	2
Safety Warnings	3
Product Identification	3

2 Installation

Unpacking the Printer.....	6
Front View.....	7
Rear View	8
Media Compartment	9
Print Mechanism.....	10
Connections.....	11
Power	11
Computer.....	11
Controls and Indicators	12
Control Lamps	12
Display	12
Control Keys	12
Beeper	12

3 Starting Up

Switching On the Printer	16
Direct Mode	17
Printing a Test Label.....	18

4 Loading Media

Tear-Off (Straight-through)	20
Peel-Off (Self-strip)	25
Thermal Transfer Printing	29
Ribbon Load.....	30

5 Printing

Controlling the Printing.....	34
Setup Methods.....	35
Navigating in the Setup Mode	35

6 Options

Stripper and Internal Rewinder	40
Installation Instructions	40
Cutter	42
Installation Instructions	42

7 Troubleshooting

Error Handling	46
Clearing Media Jam in Cutter	49
Entering the Dump Mode.....	50

8 Maintaining the Printer

Printhead Cleaning	52
External Cleaning	54
Media Jams	56

9 Adjustments

Printhead Balance Adjustment	58
Printhead Pressure Adjustment.....	59
Printhead Dot Line Position Adjustment	60
Label Gap Sensor Position Adjustment	62
Label Gap Sensor Calibration	63
Ribbon Tension Adjustment.....	64
Ribbon Shield Adjustment	65
Switching Edge Guide.....	66

A	Technical Data	
	Table of Technical Data.....	70
B	Media Specifications	
	Media Roll Size	74
	Core	74
	Internal Roll	74
	Media	75
	Non-Adhesive Strip	75
	Self-Adhesive Strip	76
	Self-Adhesive Labels.....	77
	Tickets with Gaps.....	79
	Tickets with Black Mark.....	81
C	Interfaces	
	RS-232 Interface.....	84
	Protocol.....	84
	Interface Cable	84
	USB Interface	85
	Parallel Interface.....	86
D	Firmware Upgrading	
	Requirements.....	88
	Instructions.....	88

Before You Begin

This section provides you with safety information, technical support information, and sources for additional product information.

Safety Summary

Your safety is extremely important. Read and follow all warnings and cautions in this document before handling and operating Intermec equipment. You can be seriously injured, and equipment and data can be damaged if you do not follow the safety warnings and cautions.

Do not repair or adjust alone

Do not repair or adjust energized equipment alone under any circumstances. Someone capable of providing first aid must always be present for your safety.

First aid

Always obtain first aid or medical attention immediately after an injury. Never neglect an injury, no matter how slight it seems.

Resuscitation

Begin resuscitation immediately if someone is injured and stops breathing. Any delay could result in death. To work on or near high voltage, you should be familiar with approved industrial first aid methods.

Energized equipment

Never work on energized equipment unless authorized by a responsible authority. Energized electrical equipment is dangerous. Electrical shock from energized equipment can cause death. If you must perform authorized emergency work on energized equipment, be sure that you comply strictly with approved safety regulations.

Safety Icons

This section explains how to identify and understand dangers, warnings, cautions, and notes that are in this document. You may also see icons that tell you when to follow ESD procedures.



Warning

A warning alerts you of an operating procedure, practice, condition, or statement that must be strictly observed to avoid death or serious injury to the persons working on the equipment.



Caution

A caution alerts you to an operating procedure, practice, condition, or statement that must be strictly observed to prevent equipment damage or destruction, or corruption or loss of data.



Follow ESD
Procedures

This icon appears at the beginning of any procedure in this manual that could cause you to touch components (such as printed circuit boards) that are susceptible to damage from electrostatic discharge (ESD). When you see this icon, you must follow standard ESD guidelines to avoid damaging the equipment you are servicing.



Note: Notes either provide extra information about a topic or contain special instructions for handling a particular condition or set of circumstances.

Global Services and Support

Warranty Information

To understand the warranty for your Intermec product, visit the Intermec web site at <http://www.intermec.com> and click Service & Support. The Intermec Global Sales & Service page appears. From the Service & Support menu, move your pointer over Support, and then click Warranty.

Web Support

Visit the Intermec web site at <http://www.intermec.com> to download our current documents in PDF format. To order printed versions of the Intermec manuals, contact your local Intermec representative or distributor.

Visit the Intermec technical knowledge base (Knowledge Central) at <http://intermec.custhelp.com> to review technical information or to request technical support for your Intermec product.

Telephone Support

Contact your local Intermec representative. To search for your local representative, from the Intermec web site, click **Contact**.

Related Documents

The Intermec web site at <http://www.intermec.com> contains our current documents that you can download in PDF format. To order printed versions of the Intermec manuals, contact your local Intermec representative or distributor.



1 Introduction

This chapter introduces the EasyCoder PD4 printer. The chapter covers the following topics:

- Description of EasyCoder PD4
- Safety summary
- Product identification

Description of EasyCoder PD4

The EasyCoder PD4 is a basic-performance thermal transfer/direct thermal label printer suitable for medium-duty industrial applications. With robust metal outer casing and inner mechanics, the EasyCoder PD4 provides durability, even in industrial environments.

The EasyCoder PD4 comes in three main versions:

- A** Printer with a three-key front panel, 203 dpi (dots per inch) printhead, and the options limited to keyboard/display unit and EasyLAN 10 external Ethernet adapter.
- B** Printer with a graphic display and three-key front panel for easy setup and monitoring, 203 dpi printhead, a real-time clock, and a label taken sensor. The options include stripper and rewinder unit, cutter, memory expansion module, external keyboard/display unit, and EasyLAN 10 external Ethernet adapter.
- C** Same as B, but with a 300 dpi printhead.

Please refer to Appendix A, “Technical Data” for more information.



Note: Throughout this manual, the printer models with a graphic display are described, unless otherwise stated.

Safety Warnings

- Read this manual carefully before connecting the printer.
- Moving parts are exposed when the side door is open, so ensure that the door is closed before you operate the printer.
- Do not open the front/left-hand cover. Dangerous voltage!
- Do not remove the bottom plate. Dangerous voltage!
- Do not put your fingers inside the print mechanism when the power is on.
- Place the printer on an even surface which can support its weight of approximately 13 kg (28.7 pounds) plus supplies.
- Do not spray the printer with water. If you are using a hose to clean the premises in an industrial environment, remove the printer or protect it carefully from spray and moisture.
- Carefully read the warning text on the envelope before using a cleaning card.

Product Identification

The machine label is attached to the printer's rear plate and contains information on type, model, and serial number as well as AC voltage. It also contains various signs of approval.



2 Installation

This chapter explains how to unpack and install the EasyCoder PD4 printer and also describes the printer's various parts in detail. It covers the following topics:

- Unpacking the printer
- Parts on the printer's front
- Parts on the printer's rear plate
- Parts in the media compartment
- Parts in the print mechanism
- Connecting the printer
- Using the controls and understanding the indicators

Unpacking the Printer

Before you install the printer, examine the package for possible damage or missing parts:

- Open the box and lift the printer out.
- Check that the printer has not been visibly damaged during transportation. Keep the packing materials in case you need to move or reship the printer.
- Check the label on the printer's rear plate, which gives the voltage, the part number, and the serial number.
- Check that any options you ordered are included.
- Check that all the accessories are included. As standard, the box contains:
 - Intermec EasyCoder PD4 printer
 - Power cord
 - Parallel cable
 - High edge guide
 - Empty ribbon core
 - Supporting software and product information on CD
 - Quick Start Guide.
- Check that the power cord is appropriate for the local standard. The printer works with 100 to 240 VAC, 50 to 60 Hz.

If the printer has been damaged in any way during transportation, complain to the carrier immediately.

If the delivery is incorrect or any parts are missing, report it immediately to the distributor.

Front View

At the front of the printer are the display window, the control lamps, and the control keys. These features allow the operator to control and set up the printer manually as described later in this chapter.

The printed labels, tickets, or tags are presented at the front of the print mechanism. The front cover can be removed for loading of labels at peel-off (self-strip) operation and for installation of a cutter (options).

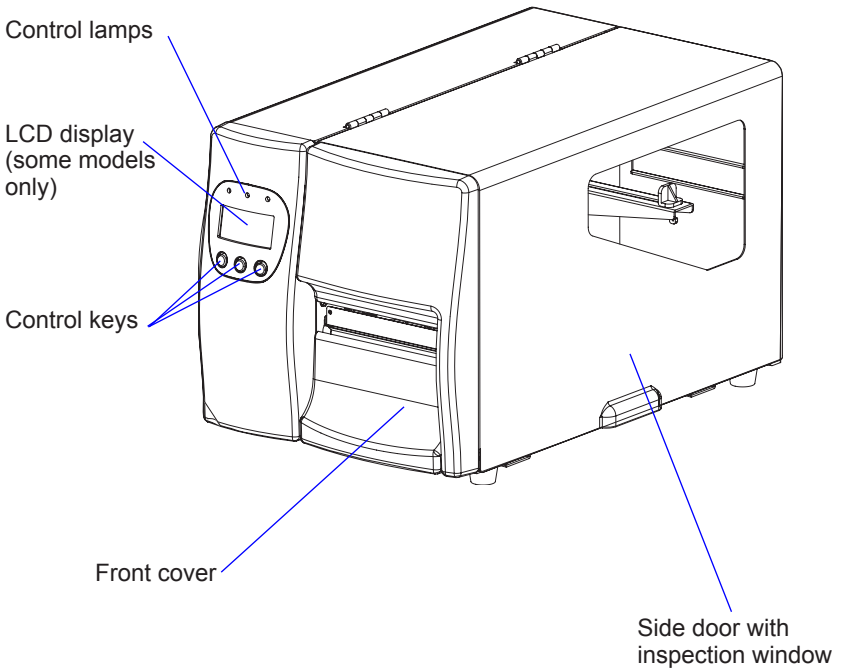

Rear View

The rear plate contains the On/Off switch, the AC power cord socket, and various interface connectors and slots.

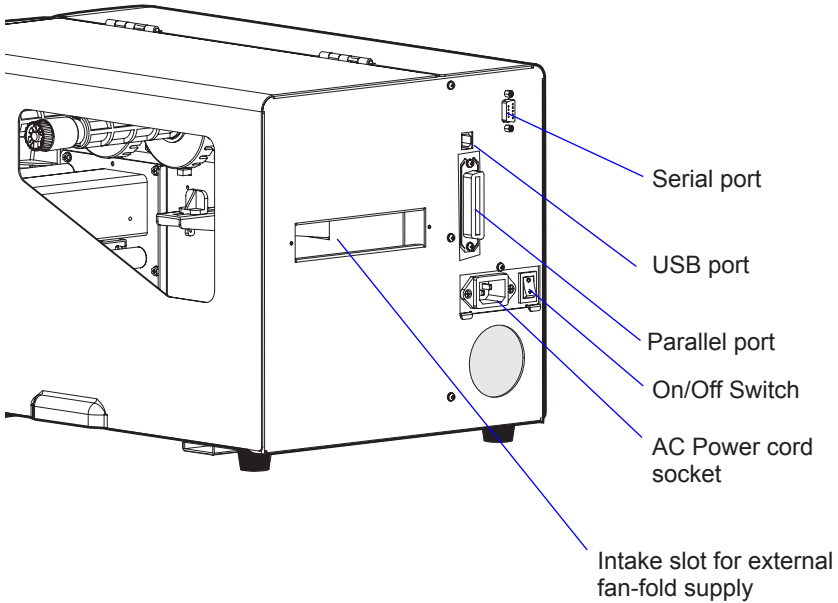

Media Compartment

The media compartment is covered by a side door that completely encloses the print mechanism and media compartment. It can be opened 180° to provide full access to the media compartment. The inspection window allows checking how much ribbon and media remains without having to open the door. The media can be supplied from a supply post, or from an external supply of fan folds behind the printer.

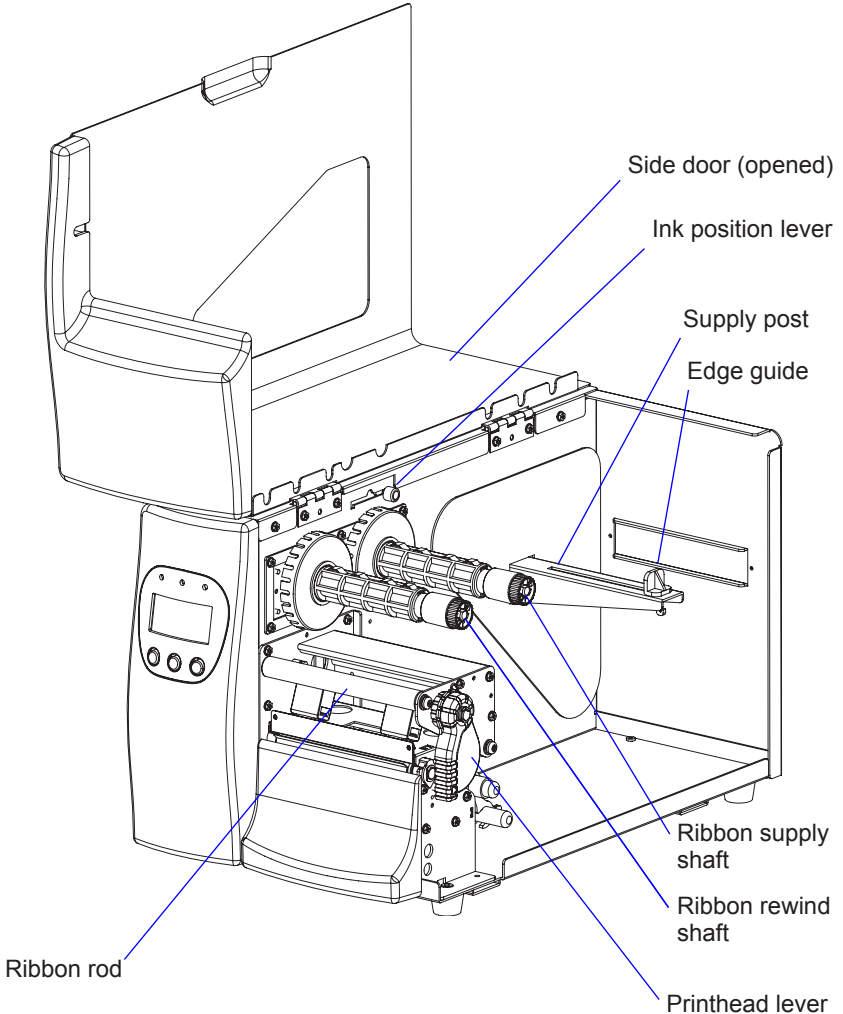

Print Mechanism

The print mechanism features either an 8 dot/mm (203.2 dots/inch) or 11.81 dots/mm (300 dots/inch) quick-mount thermal printhead.

In front of the print mechanism is a fold-out label taken sensor, which can hold the printing of next label until the previous one has been removed.

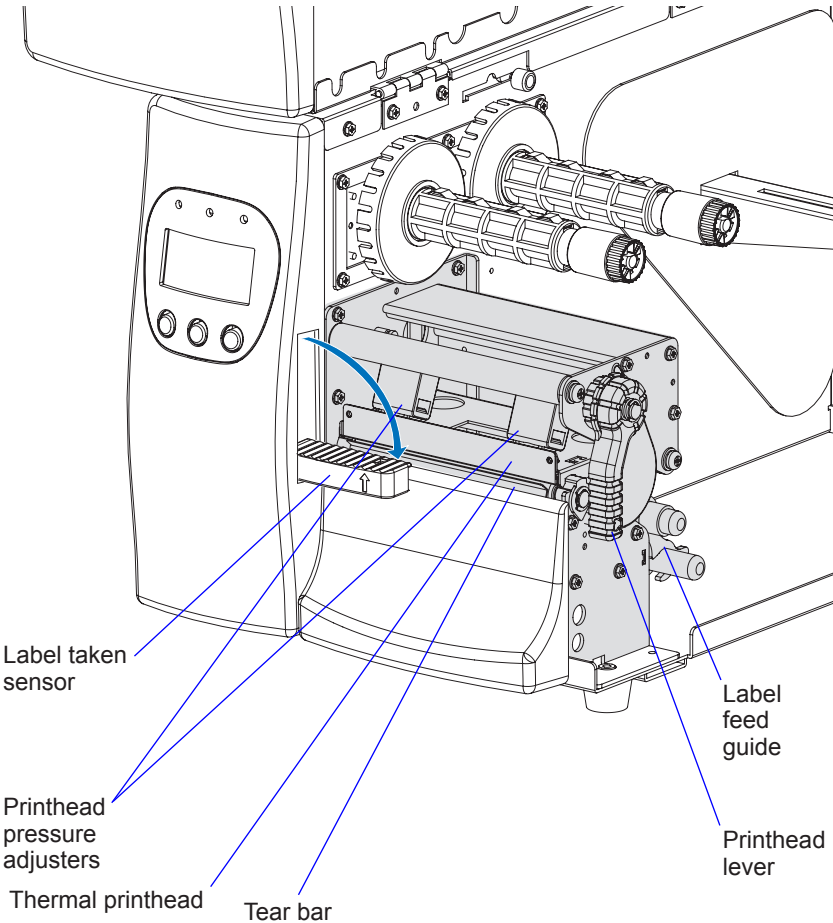

Connections

Power

- 1 Place the printer on a level surface, near an AC outlet. You should be able to easily access the printer to load media and to remove the print-out.
- 2 Both the printer and the host computer must be switched off while they are being connected.
- 3 Connect the power cord between the receptacle on the rear plate and to the electrical outlet (100 to 240 VAC).

Computer

The EasyCoder PD4 is fitted with one 36-pin Centronics socket for the parallel interface, one 9-pin D-style subminiature (DB9) socket for the RS-232 serial interface port and one class B connector for the USB interface port (see Appendix C).

Parallel Interface

Use the parallel interface with Intermec LabelShop or the Intermec InterDriver. The parallel port supports error signal and paper end signal.

RS-232 Serial Interface

Use the serial interface with Intermec LabelShop or the Intermec InterDriver. You can also use it for programming (see *Intermec ESim v5.xx for EasyCoder PD4, Programmer's Reference Manual*). Before you can use the serial interface, you may need to set up the communication parameters, such as baud rate, parity, etc. as described in Chapter 5, "Printing."

USB Interface

Use the USB interface with an USB-compatible version of the Intermec InterDriver for printing. The USB interface works in the same manner as RS-232 and is useful for error message handling (see *Intermec ESim v5.xx for EasyCoder PD4, Programmer's Reference Manual*).

Controls and Indicators

The EasyCoder PD4 has several ways of communicating directly with its operator:

- Three control lamps,
- a graphic display window with background illumination,
- three control keys,
- and a beeper.

Control Lamps

The LED (Light Emitting Diode) control lamps are labelled “Power”, “Ready”, and “Error.”

- Power (solid green) indicates that the power is on.
- Ready (solid green) indicates that the printer is ready for use.
Ready (flashing green) indicates that the printer is in downloading mode.
- Error (solid red) indicates that an error has occurred, that is, the printer is in error mode.
Error (flashing) indicates that the printer is in downloading mode.

Display

The display window contains a graphic LCD (Liquid Crystal Display) with background illumination. The display shows a fixed logotype plus two lines of text.

Control Keys

There are three membrane-switch type keys labelled “Feed”, “Pause”, and “Cancel.” What happens when a key is pressed depends on in which mode the printer presently is, see table on the next page.

Beeper

The beeper notifies the operator when an error has occurred by two short beeps and emits one short beep when an error has been cleared.

Key Functions

Mode	Feed key	Pause key	Cancel key
Startup	Print test label or Enter Dump Mode (press >3 sec.)	Enter Autosensing Mode	Cancel + Pause key: Enter Download Mode (service only)
In Direct Mode	Feed one copy	Pause Direct Mode Pause + Feed key: Enter Setup Mode	-
In Print Mode		Pause Printing Mode	
In Error Mode	Recover some error types	-	-
In Setup Mode	Select parameter or select parameter value	Enter parameter setup or set value to parameter	Exit actual param- eter and go up one level
In Dump Mode	Enter Direct Mode	-	Reset printer to default (press >3 sec.)
In paused Direct Mode	-	Enter Direct Mode	-
In paused Print Mode	-	Continue printing	Cancel printing (press >1 sec.)
In Autosensing Mode	-	-	Cancel autosensing



3 Starting Up

This chapter explains how to start up the printer after installation or after having been switched off. It covers the following topics:

- Switching on the printer
- Direct Mode
- Printing a test label

Switching On the Printer

Before switching on the printer, make the necessary connections, and check that the printhead is engaged (in the lower position).

Switch on the power using the On/Off switch on the rear plate. The green “Power” control lamp on the front panel lights up when the power is on. Wait for a few moments, while the printer starts up. Provided the printer is fitted with a display, the following message is shown:



The startup takes just a few seconds. The text line “Flash Checking” quickly disappears. You can now divert from the normal startup procedure by pressing the keys before the printer enters the Direct Mode.

- Press the Feed key for less than 3 seconds to print a test label (see later in this chapter).
- Press the Feed key for more than 3 seconds to go to the Dump Mode. Dump Mode means that the printer will print out the echo of the received ASCII data. Use this capability to debug your software when the printer does not perform as you expect. Also see Chapter 7, “Troubleshooting.”
- Press the Pause key to go to the Autosensing Mode, which is used to calibrate the label gap sensor and adjust the amount of media feed according to the distance between gaps between labels, detection slots in continuous stock, or black marks at the back of the media web. Also see Chapter 9, “Adjustments.”
- If you simultaneously press the Cancel and Pause keys, you will go to the Download Mode, which is used for service purposes only. You can only exit the Download Mode by sending a Reset command (^@) or rebooting the printer.

If you take none of the actions described above, the printer will enter the Direct Mode, which is indicated in the display window:



Direct Mode



The Direct Mode is the normal idle mode, where all commands from external ports are interpreted and normal control key actions are performed. During reception of data, this message is shown in the display:



In the Direct Mode, you can use the keys for the following purposes:

- Feed out one blank label or portion of continuous stock by pressing the Feed key.
- Pause the Direct Mode by pressing the Pause key. When the Direct Mode is paused, this message is displayed:



- Enter the Setup Mode by simultaneously pressing the Feed and Pause keys (see Chapter 5).

Printing a Test Label

An easy way to check that the printer is working and find out how it is presently set up is to print a test label. The test label can also be used to check the printout quality.

- Switch off the power to the printer.
- For best result, load the printer with full width labels or tags and transfer ribbon as described in Chapter 4.
- Hold down the **Feed** key and turn on the power again.
- Release the **Feed** key within 3 seconds.
- The printer emits a beep and “Self test” is shown in the display, if any.
- A single test label is printed.
- After the test label has been printed, the printer automatically enters the Direct Mode.

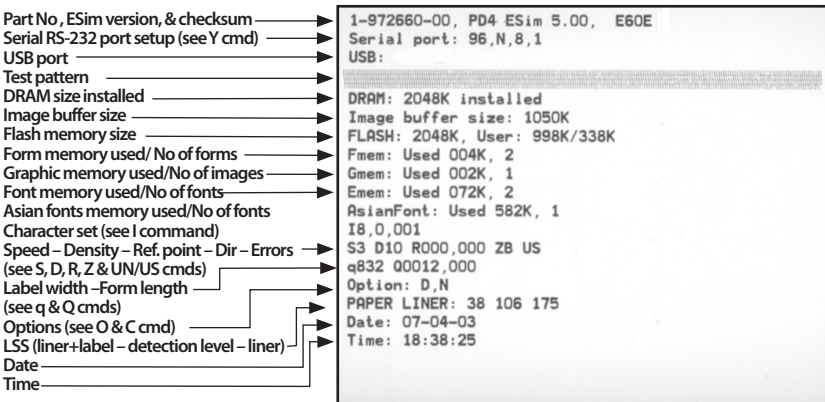

Example of a test label from an 203.2 dpi (8 dots/mm) EasyCoder PD4. For the meaning of the various commands, refer to the ESIm v5.xx for EasyCoder PD4, Programmer's Reference Manual.



4 Loading Media

This chapter explains how to load the printer with media, that is labels, tickets, tag, or strips, as well as transfer ribbon, for the following modes of operation:

- Tear-Off (straight-through)
- Peel-Off (self-strip, requires an optional stripper and internal rewinder)
- Thermal transfer printing

Tear-Off (Straight-through)

The EasyCoder PD4 can print on labels, tickets, tags, and continuous stock in various forms. This section describes the case when the media is torn off manually against the printer's tear bar. This method is also known as "straight-through printing."

Tear-off can be used for:

- Non-adhesive continuous stock
- Self-adhesive continuous stock with liner
- Self-adhesive labels with liner
- Tickets with gaps, with or without perforations
- Tickets with black marks, with or without perforations

The label taken sensor can hold the printing of the next copy in the batch until the present copy has been removed, see Chapter 2, "Installation; Print Mechanism." The label taken sensor is enabled/disabled using the ESim **O** command, see the *ESim v5.xx for EasyCoder PD4, Programmer's Reference Manual*. The point of detection is approximately 15 mm (0.6 in) outside the inner edge of the media path.



Note: When using the printer for the first time or when changing to another media with different characteristics in regard of label length, gap length, liner transparency, black mark size or position, etc., you should calibrate the label gap sensor and adjust the media feed in the Autosensing Mode, see Chapter 9, "Adjustments", after you have loaded the media.

When loading a new roll of media from the same stock as before, it is usually sufficient to press the Feed key and feed out a label.

Tear-Off, cont.

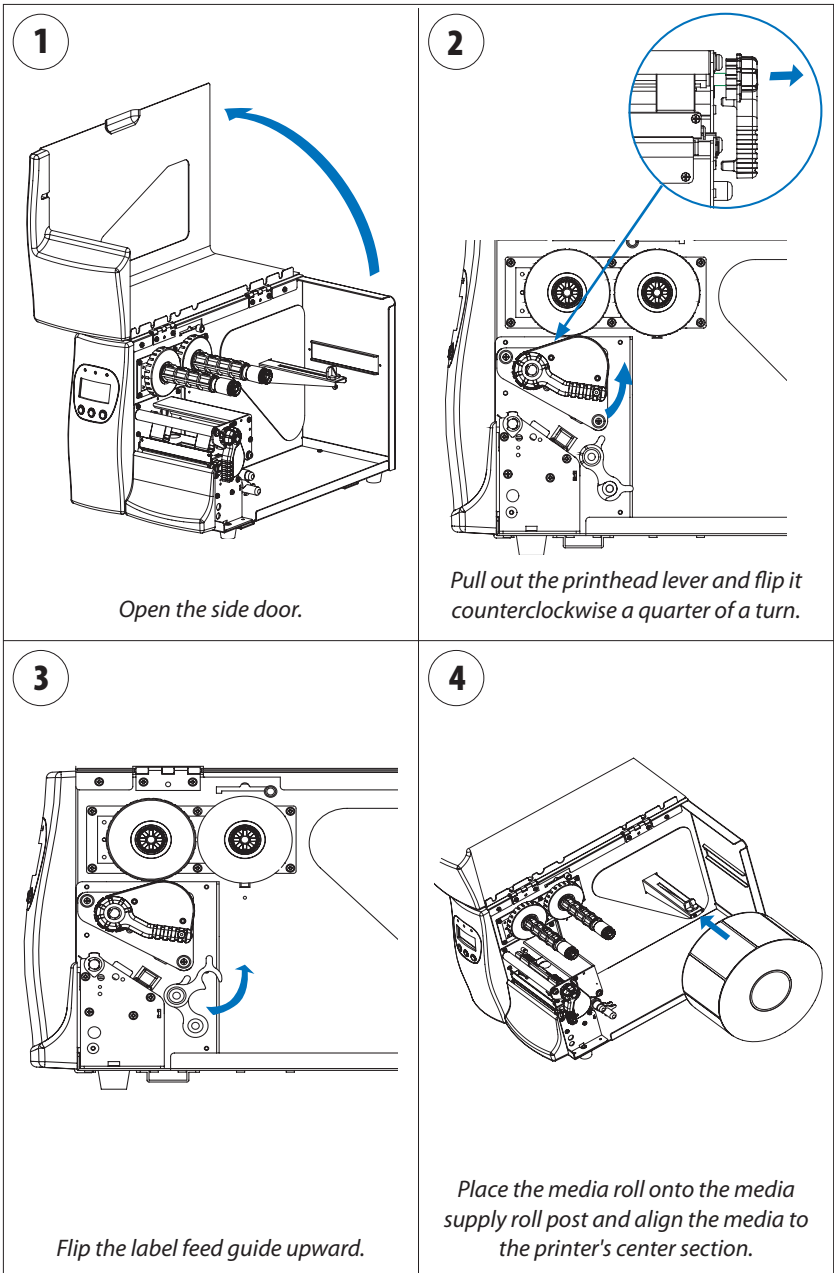

Tear-Off, cont.

5

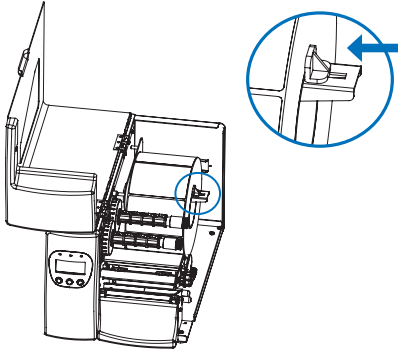

Align the edge guide with the media roll. Avoid placing the guide so it breaks the rotation of the roll.

6

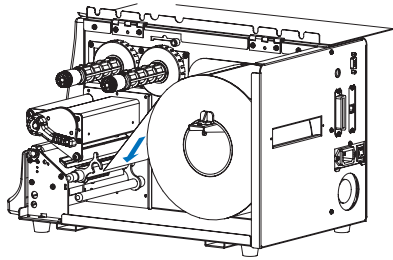

Route the media between the two label feed rods and under the moveable sensor to the tear bar.

7

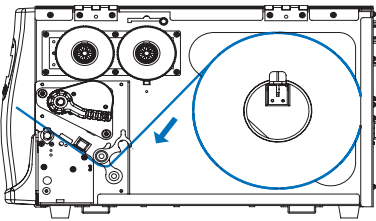

This diagram shows the media path when using an internal supply.

8

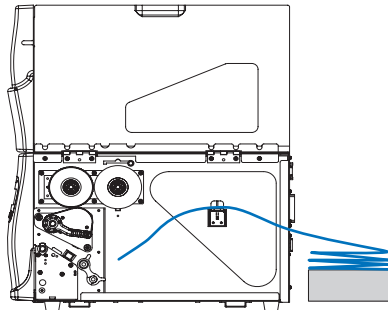

This diagram shows the media path when using an external supply of, for example, fan-folded tickets.

Tear-Off, cont.

9

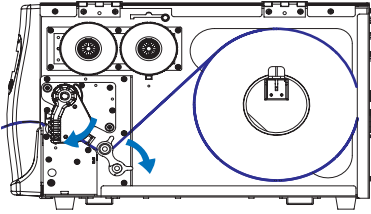

Align the media with the center section and adjust the label feed guide. Flip the guide back so it snaps to the rear label feed rod and close the printhead.

10

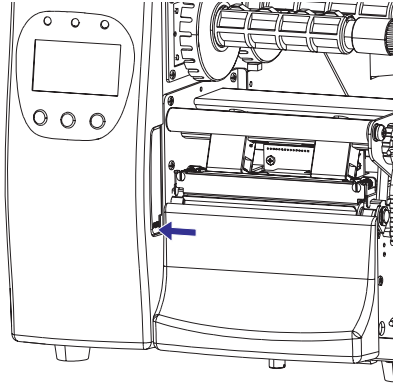

Optionally, press the lower part of the label taken sensor to flip it open.

11

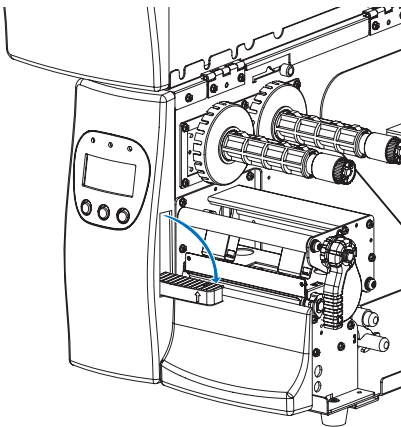

When in use, the label taken sensor should be in a horizontal position.

12

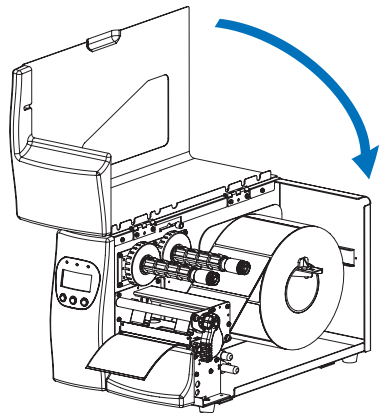

Close the side door.

Tear-Off, cont.

13

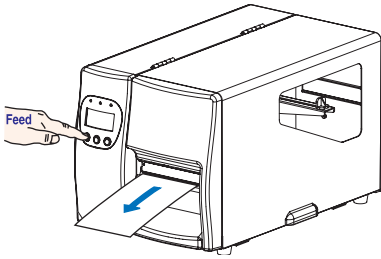

Press the Feed key to advance the media and adjust the media feed.

Peel-Off (Self-strip)

The EasyCoder PD4 can print on labels, tickets, tags, and continuous stock in various forms. This section describes the case when self-adhesive labels are separated from the liner immediately after printing. The liner is then wound up on an optional integral liner takeup hub (see Chapter 6 “Options”). This is also known as “Self-strip” operation.

Peel-off can only be used for:

- Self-adhesive labels with liner

The label taken sensor can hold the printing of the next copy in the batch until the present copy has been removed, see Chapter 2, “Installation; Print Mechanism.” The label taken sensor is enabled/disabled using the ESim **O** command, see the *ESim v5.xx for EasyCoder PD4, Programmer’s Reference Manual*. The point of detection is approximately 15 mm (0.6 in) outside the inner edge of the media path.



Note: When using the printer for the first time or when changing to another media with different characteristics in regard of label length, gap length, and liner transparency, you should calibrate the label gap sensor and adjust the media feed in the Autosensing Mode, see Chapter 9, “Adjustments”, after you have loaded the media. When loading a new roll of media from the same stock as before, it is usually sufficient to press the Feed key and feed out a label.



Note: When the liner rewinds to about 110 mm in diameter, the liner roll will touch the max. liner rewind sensor and the printer will stop printing until the liner has been removed from the printer.

Peel-Off, cont.

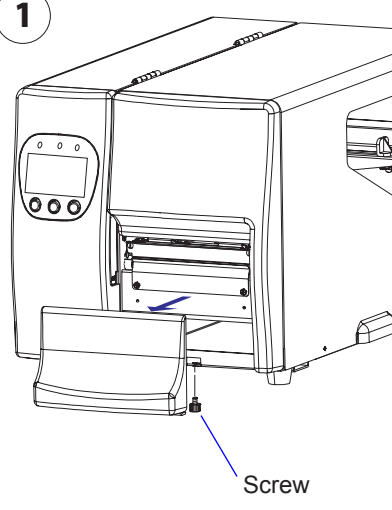
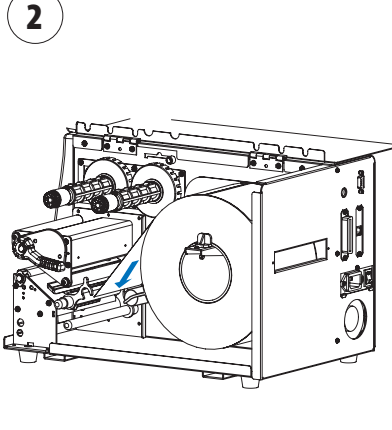
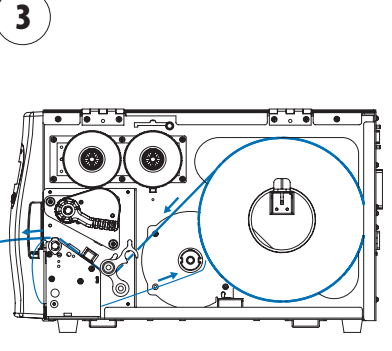
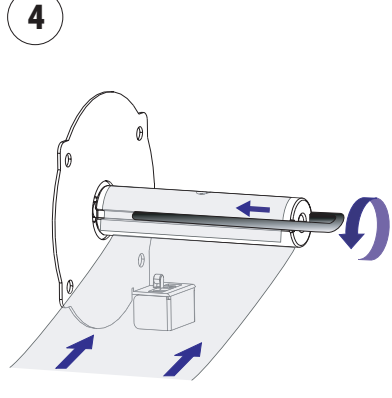
<p>1</p>  <p>Screw</p> <p><i>Unscrew the front cover screw and remove the front cover.</i></p>	<p>2</p>  <p><i>Install the media as described for Tear-Off operation #1 to #6 earlier in this chapter.</i></p>
<p>3</p>  <p><i>Peel off the labels from the first 40 cm (16 in) of the liner and route the liner around the tear bar, then back under the print mechanism and label feed rods to the takeup hub.</i></p>	<p>4</p>  <p><i>Wrap the liner counterclockwise around the takeup hub and secure it with the U-shaped clip.</i></p>

Peel-Off, cont.

5

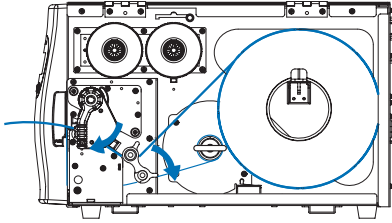

Align the media with the center section and adjust the label feed guide. Flip the guide back so it snaps to the rear label feed rod and close the printhead.

6

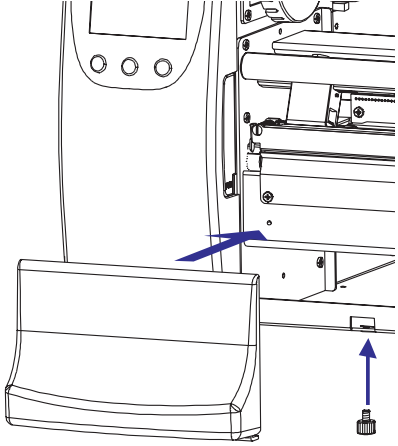

Put back the front cover and secure it with the screw.

7

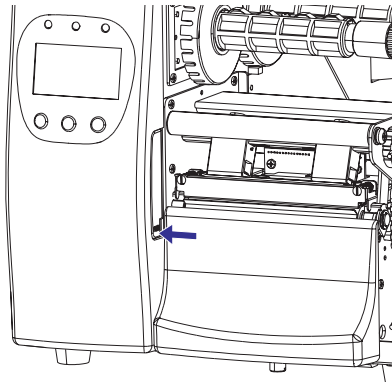

Optionally, press the lower part of the label taken sensor to flip it open.

8

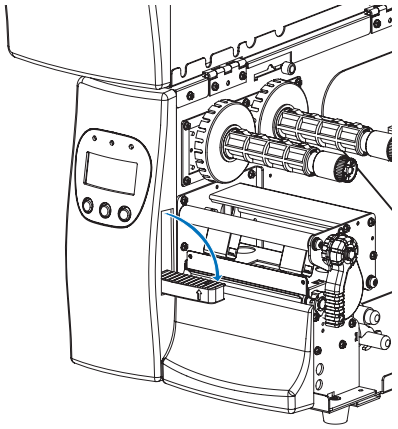

When in use, the label taken sensor should be in a horizontal position.

Peel-Off, cont.

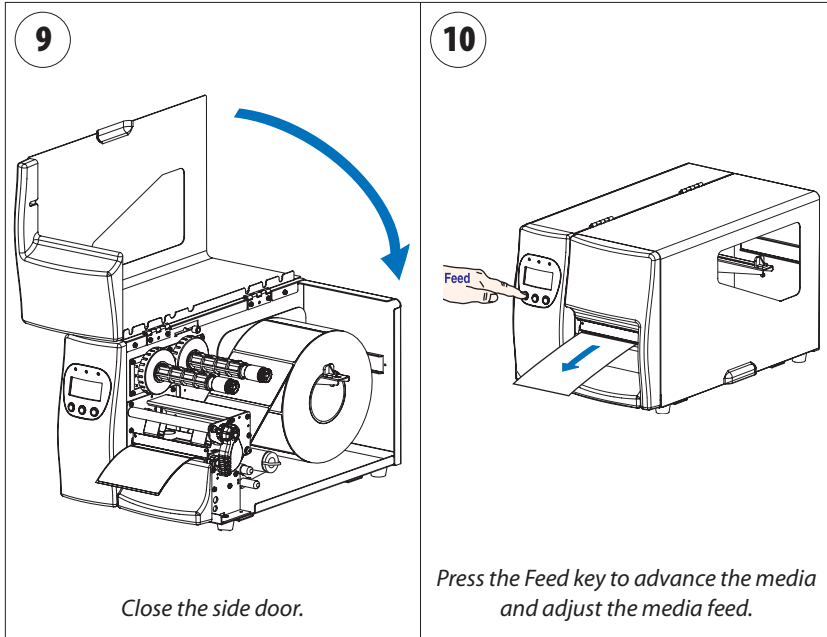

Thermal Transfer Printing

The EasyCoder PD4 can print on labels, tickets, tags, and continuous stock using either direct thermal printing on special heat-sensitive media or thermal transfer printing using a special ink-coated ribbon.

Thermal transfer printing makes it possible to use a wide range of receiving face materials and gives a durable printout less vulnerable to fat, chemicals, heat, sunlight etc. than direct thermal printing. Make sure to select a type of ribbon that matches the type of receiving face material and to set up the printer accordingly.

The EasyCoder PD4 can use transfer ribbon rolls wound with the ink-coated side facing either outward or inward. Illustrations in this manual generally show the ink-coated side facing outward.

Most transfer ribbons do not smear at room temperature.

Ribbon Load

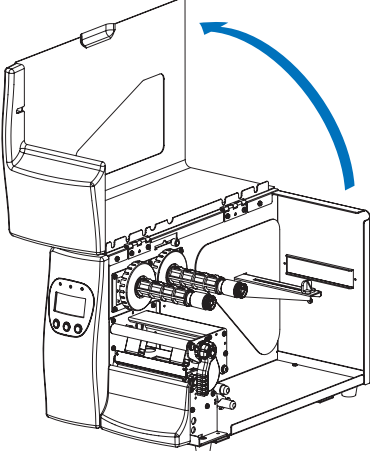
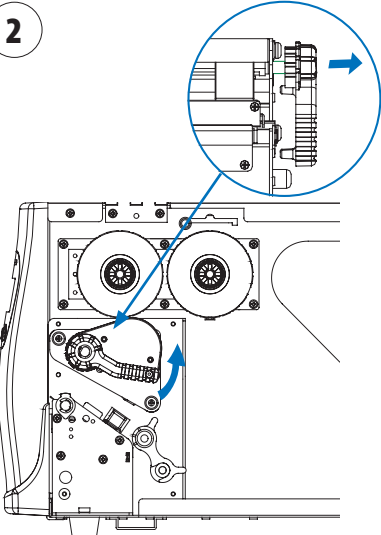
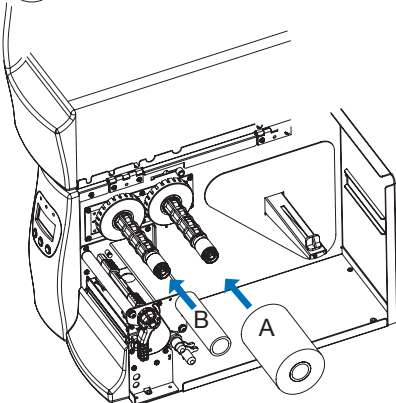
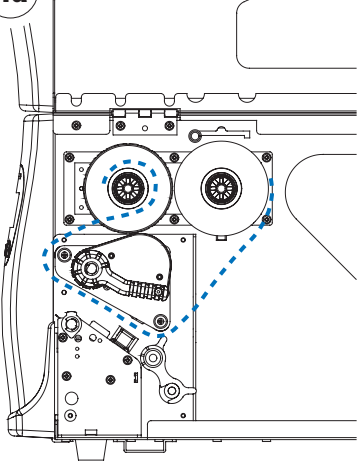
<p>1</p>  <p><i>Open the side door.</i></p>	<p>2</p>  <p><i>Pull out the printhead lever and flip it counterclockwise a quarter of a turn.</i></p>
<p>3</p>  <p><i>Load a fresh ribbon roll onto the ribbon supply shaft (A) and an empty ribbon core onto the ribbon rewind shaft (B).</i></p>	<p>4a</p>  <p><i>Ink facing outward on ribbon roll: Route the ribbon as illustrated and stick it to the take-up core.</i></p>

Ribbon Load, cont.

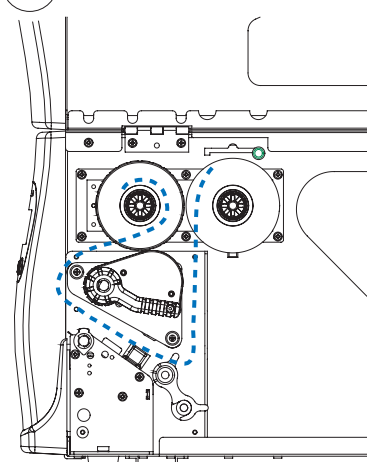
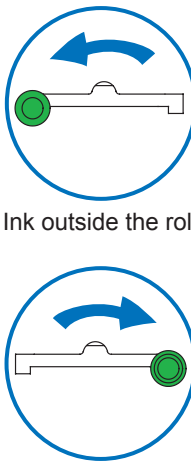
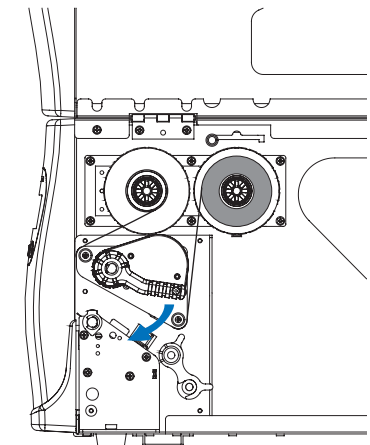
<p>4b</p>  <p><i>Ink facing inward on ribbon roll: Route the ribbon as illustrated and stick it to the take-up core.</i></p>	<p>5</p>  <p>Ink outside the roll</p> <p>Ink inside the roll</p> <p><i>Check that the ink position lever above the ribbon supply hub is in correct position.</i></p>
<p>6</p>  <p><i>Flip the printhead lever back to its original position and close the side door.</i></p>	



5 Printing

This chapter describes how the operator can control the printing. Additionally, it describes the various parameters that are accessible in the Setup Mode to configure the printer for the user's specific requirements. All these parameters and several others can also be set using ESim commands. The chapter covers the following topics:

- Controlling the printer
- Setup methods
- Navigating in the Setup Mode
- Setup options table

Controlling the Printing

The printing is initiated from the host computer, but the operator can control batch printing, that is, the printing of multiple labels.

Printing can only be performed when the printer is in the Direct Mode (see Chapter 3).

During printing, the optional display shows the quantity of printed labels or similar:



The operator can temporarily pause the printing by pressing the Pause key. This is indicated in the display like this:



The operator can also cancel the printing of the remainder of a batch print job by pressing the Cancel key for more than 2 seconds.

When the printing is completed, the display shows:



Setup Methods

The EasyCoder PD4 can be set up using two methods:

- Using ESim Commands
This method support all setup parameters and uses various ESim commands transmitted from the host computer to the printer. Please refer to *ESim v5.xx for EasyCoder PD4, Programmer's Reference Manual*.
- Using the display window and keys on the printer's front panel. This method only supports some setup parameters, namely those that are important for the operator. It can only be used if the printer has a display.

Navigating in the Setup Mode

You can enter the Setup Mode from the Direct Mode by holding down the Pause key and simultaneously pressing the Feed key. This display message will appear:



While you are in the Setup Mode, the keys labelled Feed, Pause, and Cancel get new functions as indicated by the text in the bottom line of each display message:

Key	Key label in display	Function in the Setup Mode
Feed	Select	Go to next option or level, that is, down in the table on the next page.
Pause	Enter	Select the displayed option or value, that is, to the right in the table on the next page.
Cancel	Exit	Leave the displayed level and go back to the previous one, that is up or to the left in the table on the next page.

Press the Feed key to go to the first menu in the Setup Mode (Media Type). The levels are endless loop, where the presently selected options are indicated by inverted text (white on black).

Setup Options		Note	
Media Type	Direct Thermal	Default	
	Thermal Transfer		
Density (see note on the next page)	1	(lightest image)	
	Default 10	
	15	(darkest image)	
Speed	2" per second		
	3" per second		
	4" per second	Default	
	5" per second	Not with 300 dpi	
	6" per second	Not with 300 dpi	
Option	Strip Mode		
	Cutter Mode		
	Option Off	Default	
Paper type	Black Mark		
	Gap Paper	Default	
	Plain Paper		
Com Port Set	Baud Rate	4800 bps	
		9600 bps	Default
		19200 bps	
		38400 bps	
	Parity Setup	No Parity	Default
		Odd Parity	
		Even Parity	
	Data Length	7 bits	
		8 bits	Default
	Stop bit	1 bits	Default
2 bits			
LCD Language	English	Default	
	Simplified Chinese	Chinese characters	
	Traditional Chinese	Chinese characters	
Setting review	Review setting items without any changes (scroll by pressing Pause)		
Exit	Exit & Save	Default	
	Exit & No save		



Note: Do not use a higher density setting than required for your media and application. Lower density setting saves your printhead and extends its life.

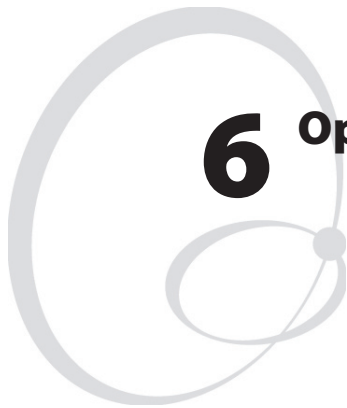

6 Options

This chapter describes the options available for the EasyCoder PD4 printer. The options can be factory installed, field-installed by an authorized service technician, or installed by a trained operator. The options are:

- Stripper and Internal Rewinder
- Cutter

Stripper and Internal Rewinder

Installation Instructions

- 1 Remove the screw that holds the front cover. Remove the front cover.

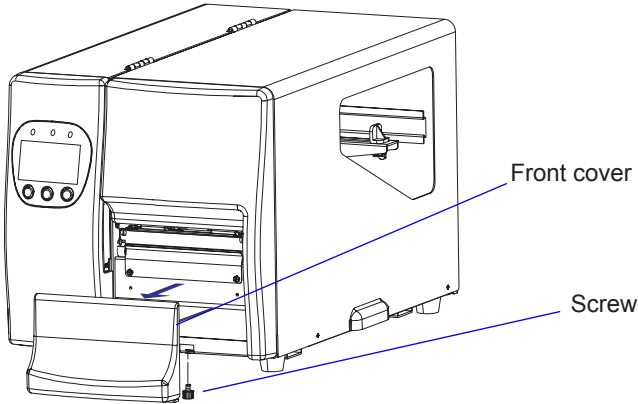

- 2 Open the side door and remove the rewinder option cover plate, which is held by two Phillips screws.

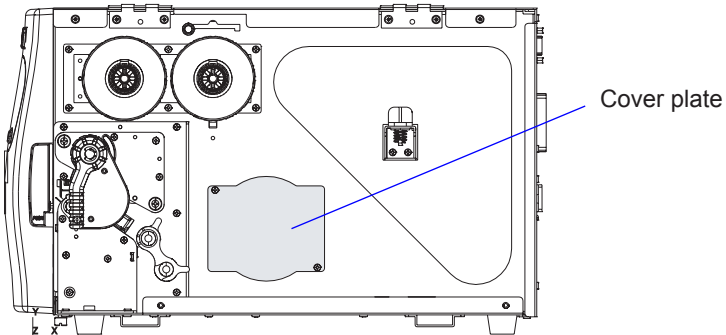

- 3 Remove the U-shaped clip and attach the rewinder unit to the center section using the four screws included in the kit.

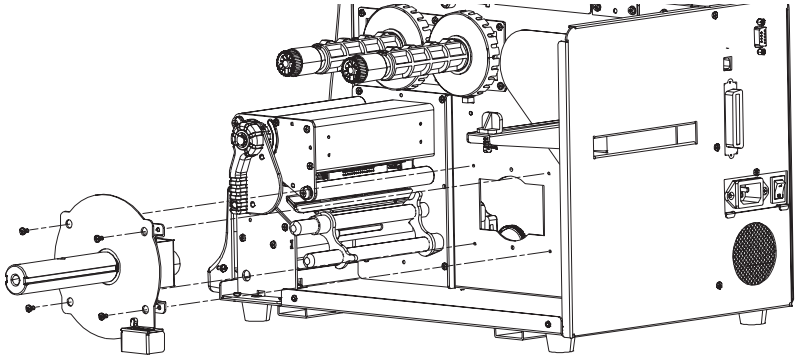

- 4 Plug in the cable from the rewinder switch into the front one of the two connectors in the center section.

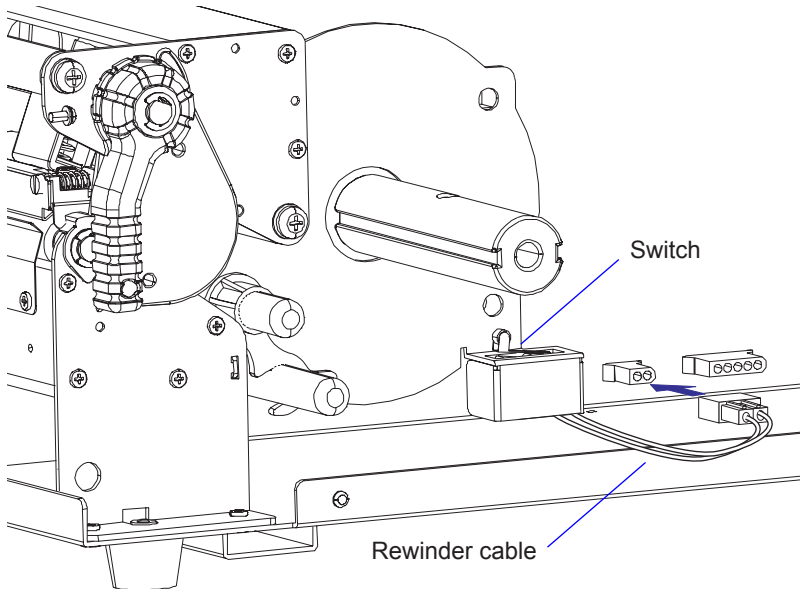

- 5 Install the media as described in Chapter 4 “Media Load”, section “Peel-off (Self-strip).”

Cutter

Installation Instructions

- 1 Remove the screw that holds the front cover. Remove the front cover.

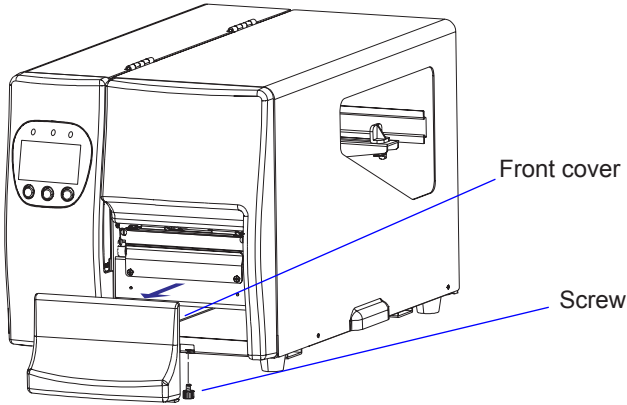

- 2 Open the side door and remove the tear bar, which is held by two Phillips screws.

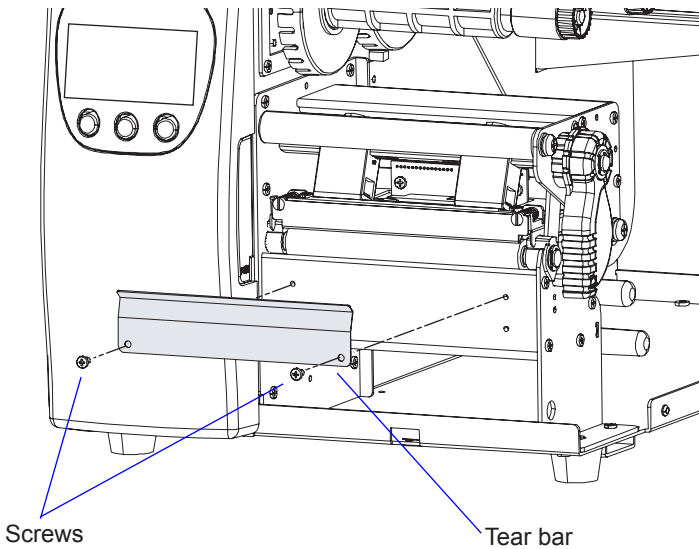

- 3 Attach the cutter mechanism to the printer using the two Phillips screws and washers included in the kit.

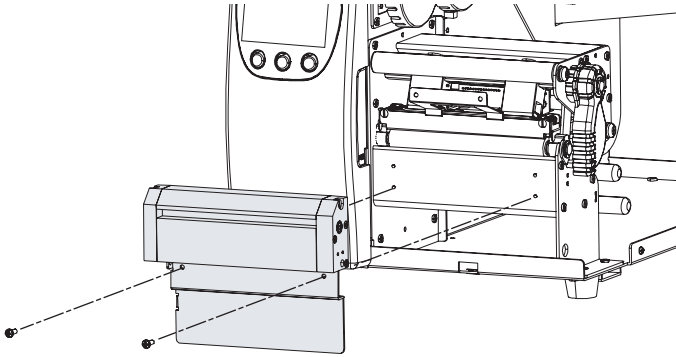

- 4 Plug in the cable from the cutter into the rear one of the two connectors in the center section and fasten the cable to the bottom plate using the two cable clips included in the kit.

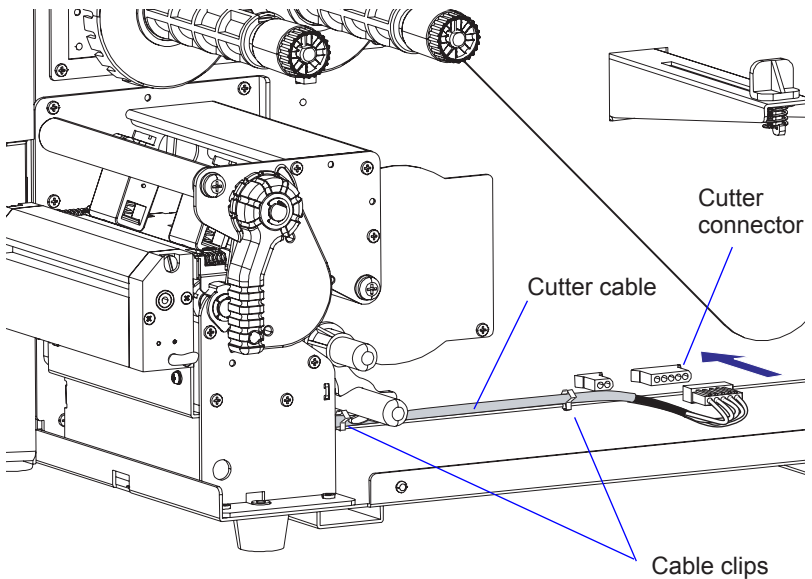

Chapter 6—Options

- 5 Attach the cutter cover onto the cutter mechanism by first connecting the hooks on the back side of the cover over the cutter mechanism and then locking the cover with the screw at the bottom.

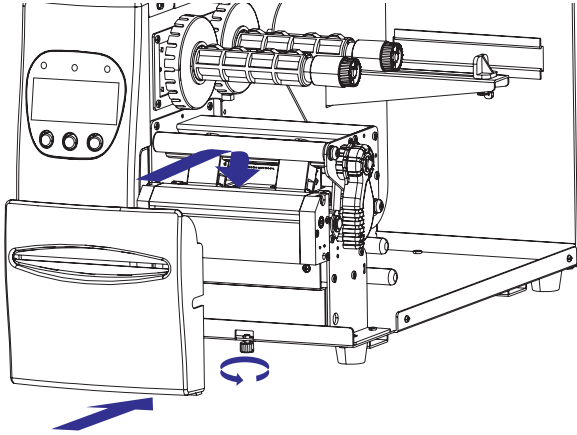

- 6 If needed, fit the tray to the front of the cutter.

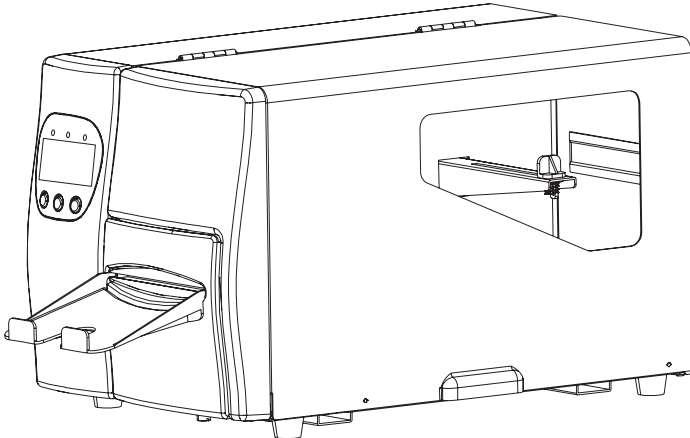

- 7 Install the media as described in Chapter 4 “Media Load”, section “Tear-off (Straight-through)”. Recommended label/paper length is at least 30 mm (1.18 in).



Note: Make sure that the printer is set to use the cutter, either in the Setup Mode (see Chapter 7) or using an **O** command, see *ESim v5.xx for EasyCoder PD4, Programmer’s Reference Manual*. The label taken sensor cannot be used with the cutter.



7 Troubleshooting

This chapter lists various possible cases of inferior printout quality, describes possible causes, and suggests remedies.

Error Handling

When an error occurs, the Error LED goes solid or flashing red and the beeper emits two beeps. Provided the printer is fitted with a display, two error message are displayed alternately, for example:



When all errors have been cleared, the Error LED goes off, the beeper emits a single beep, and the printer returns to the same mode as when the error occurred, which is indicated in the display window.

The printer's error-handler can manage the following errors:

Description/Display Message	Action
01: Syntax error	Press the Feed key
02: Object exceeds image buffer border	Press the Feed key
03: Data length error	Press the Feed key
04: Insufficient memory to store data	Press the Feed key
05: Memory configuration error	Press the Feed key
07: Out of media	Load new supply of media
08: Form or image name duplicate	Press the Feed key
09: Form or image not found	Press the Feed key
11: Print head lifted	Close the printhead
13: Label taken sensor waiting	Remove label
15: Rewinder is full	Remove wound-up liner
16: No form was retrieved before '?'	Press the Feed key
17: Out of ribbon	Load new supply of ribbon
50: Does not fit in area specified	Press the Feed key
51: Data length too long	Press the Feed key
62: High print head temperature (WAIT)	Wait for printhead to cool off
71: Default Setup retrieved (RESET)	Switch power off/on or send ^@ cmd
72: Flashing not completed (RESET)	Switch power off/on or send ^@ cmd
73: Download error (RESET)	Switch power off/on or send ^@ cmd
81: Cutter jammed or not installed	Clear media from cutter or disable cutter

Error	Suggested action
The Power control lamp does not shine and the LCD display (if any) shows no message after the power has been switched on	Check the power cable
Error LED light turns solid red after printing stops	Check for bad software setting or ESim command errors
	Check if printer is out of media or ribbon
	Check if media is jammed/tangled up
	Check if mechanism is not locked and closed
	Check if label gap sensor is blocked by media
	Check cutter (if any)
Printing started, but nothing was printed on the label	Check if media is placed upside down or if media is not suitable for the application
	Check if the ink-coted side of the transfer ribbon faces the media
	Select the correct printer driver
	Select the correct media and print type
	Check that the printhead is properly connected to the print mechanism
When printing, label is jammed/tangled up	Clear the media jam, and if label is stuck on thermal printhead, remove it using a cleaning card or a soft cloth soaked with isopropyl alcohol
When printing, part of the print image was not printed along the feed direction	Check if thermal printhead needs cleaning
	Check if application software has errors
	Check ribbon for creases and wrinkles. See Ribbon Tension Adjustment and Ribbon Shield Adjustment in chapter 9.

Chapter 7—Troubleshooting

Printout not in desired position	Check for bad settings in the application or ESim command errors
	Check if label gap sensor is disturbed by media, dust, or erroneously loaded transfer ribbon
	Check lateral position of label gap sensor
	Calibrate label gap sensor in Autoadjust Mode
	Check the edge guide and media guides
	Check the media (too little liner transparency, weak black marks, or interfering preprint at the back of the media?)
	Check if platen roller needs cleaning or replacement
When printing, page skipping occurs	Check if label gap sensor is disturbed by dust or foreign objects
Weak printout	Check density setting
	Check if thermal printhead needs cleaning
	Check printhead pressure
	Check printhead dot line position
Uneven darkness across media path	Check printhead balance
When using cutter, label was not cut straight	Check if media is loaded correctly
When using cutter, label was not cut successfully	Check whether media thickness exceeds 0.16 mm (6.3 mils)
	Check if media is loaded correctly
When using cutter, label could not feed or abnormal cutting occurs	Check if cutter is installed properly
	Check if paper feed rods are sticky. Clean if necessary using isopropyl alcohol
When using stripper, abnormal function occurs	Check if stripper full sensor is working
	Check if media is loaded properly
 Note: If further problems should occur, please contact your distributor for more information.	

Clearing Media Jam in Cutter

To clear a media jam inside the cutter mechanism, follow the instructions below:

- 1 At media jams and cutter malfunctions, switch off the power to the printer.



Warning

Never insert fingers or tools into the printer while the power is still on.

- 2 Insert a 3 mm hexagon screwdriver in the hole on the side of the cutter (A) and turn the cutter blade clockwise.
- 3 After the media jam is cleared, switch on the power to the printer, and the cutter blade will go back to its original position.



Note: It is recommended to use labels with a length of 30 mm (1.18 in) or more.

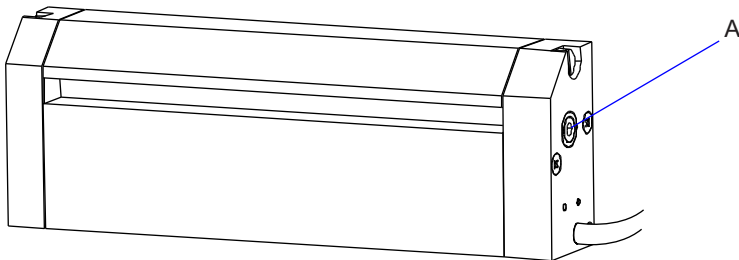

Entering the Dump Mode

In the Dump Mode, the printer prints all received ASCII characters including control characters (ASCII 00-31 decimal). There is automatic line-wrapping and if a label becomes completely filled, the dump continues on a new label. This facility is useful for debugging.

Enter the Dump Mode like this:

- 1** Switch off the power to the printer.
- 2** Press and hold the Feed key while you switch on the power again.
- 3** The Feed key must be pressed for more than 2 seconds after power up (else a test label will be printed).
- 4** When the printer is in Dump Mode, this message will be displayed provided the printer is fitted with an optional display:



In the Dump Mode, you can reset the printer to its default setup values by pressing the Cancel key for 3 seconds or more.

To exit the Dump Mode and enter the Direct Mode, tap the Feed key.



8 Maintaining the Printer

This chapter describes how the operator can maintain the printer. Regular maintenance is important for the printout quality and for the life of the printhead. The chapter covers the following topics:

- Printhead cleaning
- External cleaning
- Printhead replacement.
- Media jams.

Printhead Cleaning

Cleaning the printhead on a regular basis is important for the life of the printhead and for the printout quality. You should clean the printhead using cleaning cards or a cotton swab moistened with isopropyl alcohol, preferably each time you load a new supply of transfer ribbon.



Warning

Isopropyl alcohol [(CH₃)₂CHOH; CAS 67-63-0] is a highly flammable, moderately toxic, and mildly irritating substance.

- 1 Open the side door.
- 2 Remove the media and ribbon.
- 3 Lift the printhead by pulling out the printhead lever and flipping it counterclockwise a quarter of a turn.
- 4 Use a cleaning card or a soft cotton swab moistened with isopropyl alcohol to dissolve any contamination at line of heat-emitting dots at the front/bottom edge of the printhead.
- 5 After approximately 30 seconds, carefully rub off any contamination. Repeat if necessary.



Caution

Never use any hard or sharp tools to peel away stuck labels or similar. The printhead is delicate and can easily be damaged.

- 6 Allow the printhead to dry for a minute or so before loading a new supply of media and ribbon.

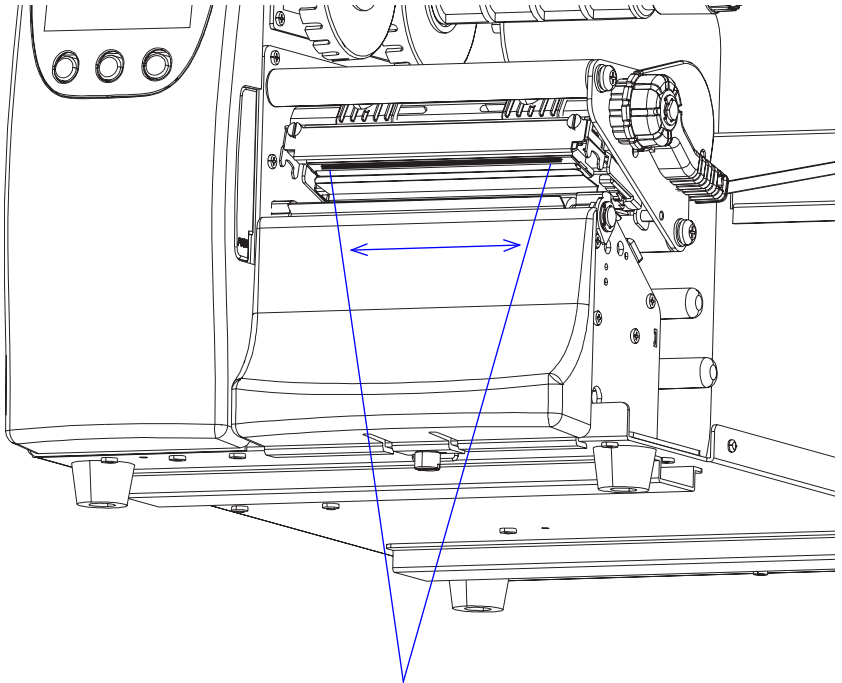

Clean the printhead dot line.

External Cleaning



Warning

Always unplug the power cord before cleaning the printer.

If using the printer in an industrial environment, where the premises may be cleaned using a water hose or steam, move the printer to another room or cover it carefully with a plastic sheet and make absolutely sure that the power cord is unplugged.

Clean the external surfaces using a soft cloth, possibly slightly moisten with water or a mild detergent.

Stuck labels should be peeled away using your fingers only. If necessary, dissolve the adhesive using isopropyl alcohol first.



Warning

Isopropyl alcohol [(CH₃)₂CHOH; CAS 67-63-0] is a highly flammable, moderately toxic, and mildly irritating substance.

Printhead Replacement

The printhead is subject to wear both from the direct thermal media (or ribbon) and from the rapid heating and cooling process during printing. Thus, the printhead will require periodic replacement.

Time between printhead replacements depends on the print images, the type of direct thermal media (or ribbon) in use, the amount of energy to the printhead, the print speed, the ambient temperature, and several other factors.



While replacing the printhead, the power must be off. The firmware will not detect the new printhead resistance until the printer has been restarted.



Take precautions against electrostatic discharges by touching a grounded object, for example the chassis of the printer (assuming the printer is connected to a grounded wall socket).

Install a replacement printhead this way:

- 1 Switch off the power to the printer.
- 2 Open the side door.
- 3 Lift the printhead by pulling out the printhead lever and flipping it counterclockwise a quarter of a turn.
- 4 Remove any transfer ribbon.
- 5 Pull out the printhead straight forward.
- 6 Insert the replacement printhead so it engages the connectors on the printhead bracket.
- 7 Reload the transfer ribbon, close the printhead, close the side door and switch on the power.

Media Jams

Should a media jam occur in the print mechanism, proceed this way to clear it:

- Always switch off the power before starting to clear the jammed media.
- Raise the printhead and pull out the media.
- If the media has been wound up or has stuck on the platen roller, carefully remove it by hand without using any sharp tools that can damage the delicate platen roller or printhead. Avoid rotating the platen roller.



Caution

If you must pull away the media by force causing the platen roller to rotate, it is very important that the power has been off for a minute or more. If not, the electronics can be damaged beyond repair.

- Cut off any damaged or wrinkled part.
- Check if there is any adhesive somewhere in the print mechanism, clean using a cleaning card or cotton swab soaked in isopropyl alcohol.



Warning

Isopropyl alcohol [(CH₃)₂CHOH; CAS 67-63-0] is a highly flammable, moderately toxic, and mildly irritating substance.

- Reload the media as described in Chapter 4.
- Switch on the power.
- Readjust the media feed by pressing the Feed key.



9 Adjustments

This chapter describes how the operator can adjust the printer. The chapter covers the following topics:

- Printhead balance adjustment
- Printhead pressure adjustment
- Printhead dot line position adjustment
- Label gap sensor position adjustment
- Label gap sensor calibration
- Ribbon tension adjustment
- Ribbon shield Adjustment
- Switching edge guide

Printhead Balance Adjustment

The printer is factory-adjusted for full-size media width. When using media less than full width, it is recommended that you adjust the position of the printhead balance boxes so the printhead gets an even pressure across the media.

A poorly adjusted printhead pressure may be detected by a weaker print-out on either side of the media path.

To adjust the pressure, proceed as follows:

- 1 Open the top cover.
- 2 Remove the ribbon.
- 3 Lift the printhead by pulling out the printhead lever and flipping it counterclockwise a quarter of a turn.
- 4 Move the balance box on the right side (outer) outward (to the right) for wider media and inwards (to the left) for more narrow media.

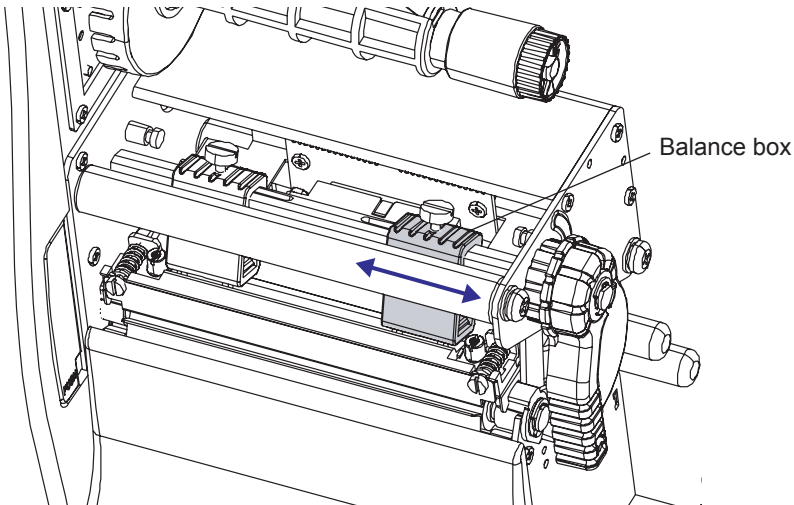

- 5 Engage the printhead and load the ribbon.
- 6 Test and readjust if necessary. (Hint! If you use direct thermal media you will not have to load and remove the ribbon over and over again.)

Printhead Pressure Adjustment

The pressure of the thermal printhead against the platen roller is factory-adjusted. However, if the printing is weaker on one side of the media or if the thermal transfer ribbon starts to crease (indicated by unprinted white streaks along the media feed direction), it may be necessary to readjust the printhead pressure.



Note: Before readjusting the pressure, try to fix the problem by moving the outer balance box as described earlier in this chapter.

- 1 Open the top cover.
- 2 Remove the ribbon.
- 3 Lift the printhead by pulling out the printhead lever and flipping it counterclockwise a quarter of a turn.
- 4 Use a straight-slot screwdriver to turn the screw at the top of the balance boxes clockwise to increase the pressure or counterclockwise to decrease the pressure.

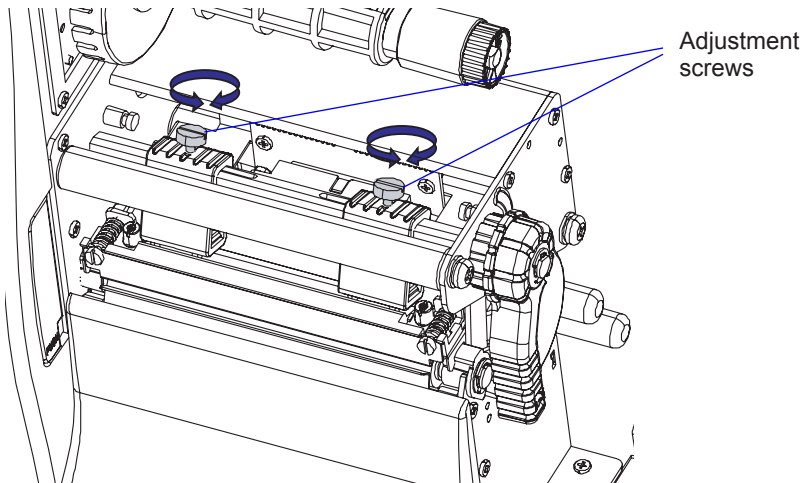

- 5 Engage the printhead and load the ribbon.
- 6 Test and readjust if necessary. (Hint! If you use direct thermal media you will not have to load and remove the ribbon over and over again.)

Printhead Dot Line Position Adjustment

When using thick or stiff media, the printhead needs to be moved forward so the dot line becomes exactly aligned with the top of the platen roller. Obviously, the platen roller and printhead must also be completely in parallel.

To perform this adjustment, follow the steps below:

- 1 Open the top cover.
- 2 Remove the ribbon.
- 3 **Important step!** Use a straight-slot screwdriver to turn the two screws at the top of the printhead bracket counterclockwise a single turn.

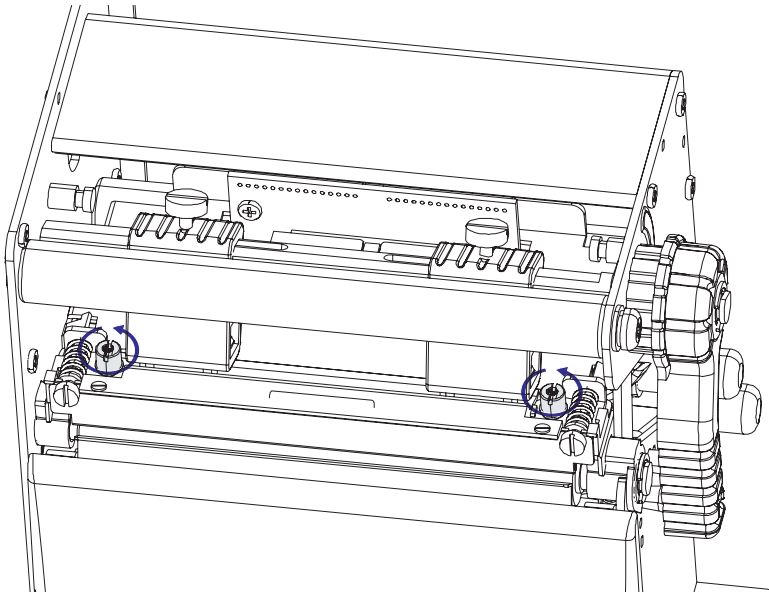

- 4 Lift the printhead by pulling out the printhead lever and flipping it counterclockwise a quarter of a turn.

- 5 Turn both screws at the front of the printhead carefully clockwise a **quarter of a turn** at a time (a full turn corresponds to 0.5 mm which is a lot). Make sure to make identical adjustments on both the screws! If you get lost, tighten both screws by turning them counterclockwise as far as they go and start all over again.

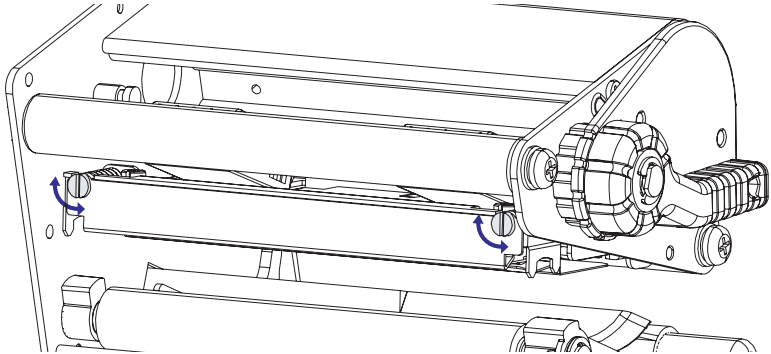

- 6 Engage the printhead and Lock the printhead by tightening the two screws at the top of the printhead bracket, that is, the reverse action of step #3.
- 7 Load the ribbon (only in case of thermal transfer printing).
- 8 Test and readjust if necessary. (Hint! If you use direct thermal media you will not have to load and remove the ribbon over and over again.)

Label Gap Sensor Position Adjustment

The label gap/black mark sensor is a photoelectric sensor that controls the printer's media feed by detecting gaps between labels, or slots or black marks in continuous stock, depending on the printer's setup in regard of media type (see Chapter 5, "Printing"). An obvious prerequisite is that the sensor must be aligned with the gaps, slots, or black marks. If using irregularly shaped labels, align the sensor with the front tips of the labels.

Use the lever at the rear side of the print mechanism to move the sensor inward or outward. The point of detection can be seen from the front when the printhead is lifted.

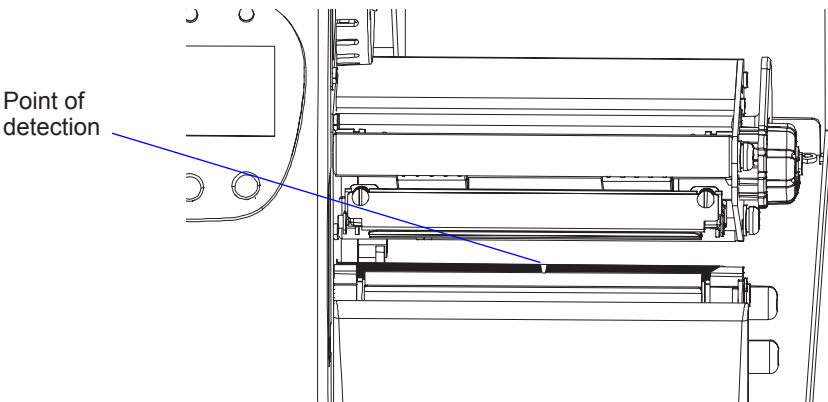
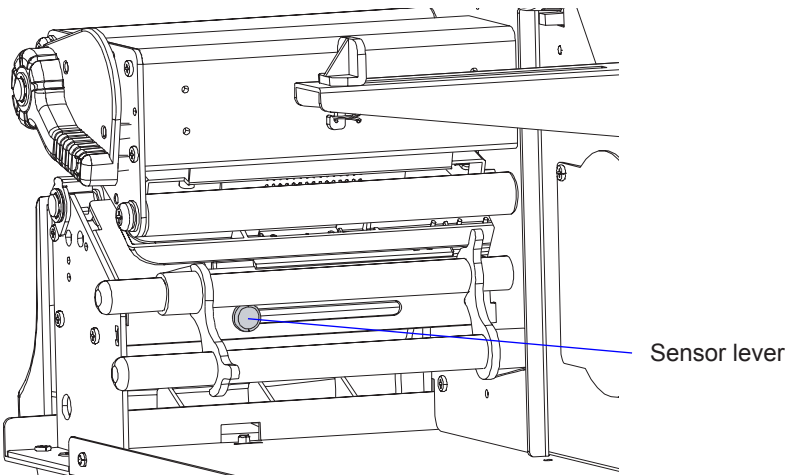

Label Gap Sensor Calibration

The label gap sensor will need to be calibrated and the media feed adjusted at the following occasions:

- After media load when the printer is used for the first time.
- After loading media that differs from the previously loaded in regard of type (gaps, black marks, or continuous), size and location of gaps or black marks, or transparency of the liner.
- When the printer starts feeding out labels or similar in an unexpected way or when the print image becomes positioned in the wrong place.

The calibration is performed in the Autosensing Mode. Do like this:

- 1 Switch off the printer.
- 2 Switch on the printer while holding the Pause key.
- 3 If the printer is fitted with a display, it will show the following message:



- 4 The printer will feed out some labels or similar while checking the characteristics of the media and autoadjust the sensitivity and the feed parameters.
- 5 Provided the printer has a display, one of the following messages is briefly displayed depending on type of media, when the calibration is completed:



- 6 The printer switches automatically to the Direct Mode.

To break the Autosensing Mode before it is finished and enter the Direct Mode, press the Cancel key.

Ribbon Tension Adjustment

If ribbon wrinkling occurs during printing, push the knob at the end of the ribbon supply hub inwards (1) and rotate it clockwise to increase the breaking force (2).

If the printer have problems pulling the labels (especially when using a ribbon less than 50 mm/2 in wide), push the knob at the end of the ribbon supply hub inwards (1) and rotate it counterclockwise to decrease the breaking force (2).

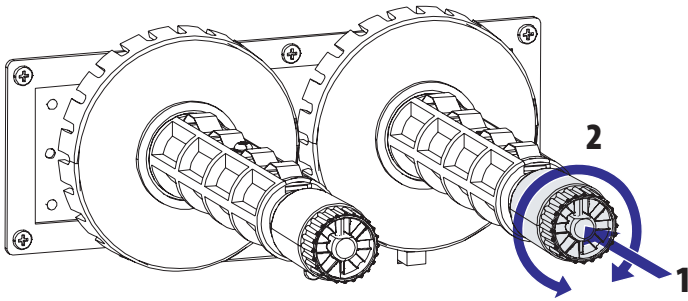

Ribbon Shield Adjustment

Ribbon wrinkling can also be avoided using the ribbon shield mechanism. The ribbon shield mechanism is located on the thermal printhead, and has two adjustable screws A and B shown below.

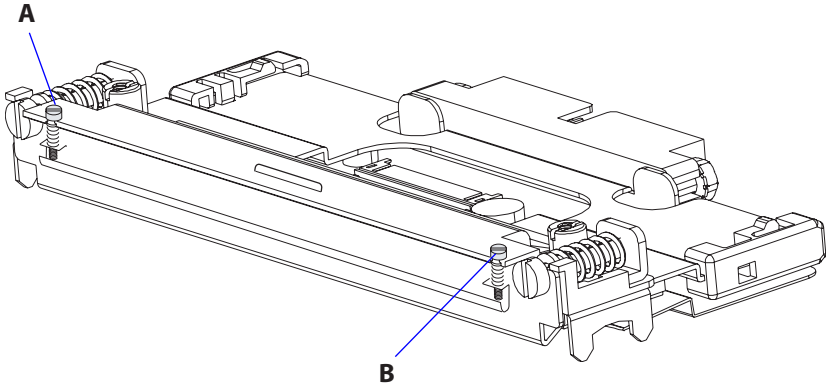

If the label printout occurs as in Test label A, turn screw A clockwise. If the printout occurs as in Test label B, turn screw B clockwise. Turn the screw half a circle and perform a new test printing. Continue until you achieve a smooth print quality. Screw adjustment must not exceed two full turns. In such a case, paper feed may not be smooth and the screws need to be turned counterclockwise completely and readjusted from start.



Switching Edge Guide

As standard, the EasyCoder PD4 is fitted with a low edge guide on the media supply roll post. The low edge guide makes it simple to fit a media supply roll on the post, but it only guides the core of the roll. Therefore, the EasyCoder PD4 is delivered with an enclosed high edge guide which the user can fit quite easily when the application so requires, for example when the printer cannot be placed on a horizontal surface or when the media roll tends to unwind itself.

To replace the edge guide, follow these steps:

- 1 Unhook the coil spring from the hook at the bottom of the plastic edge guide underneath the post.
- 2 Remove the coil spring and the washer, then pull up the edge guide and save it away for possible later use.

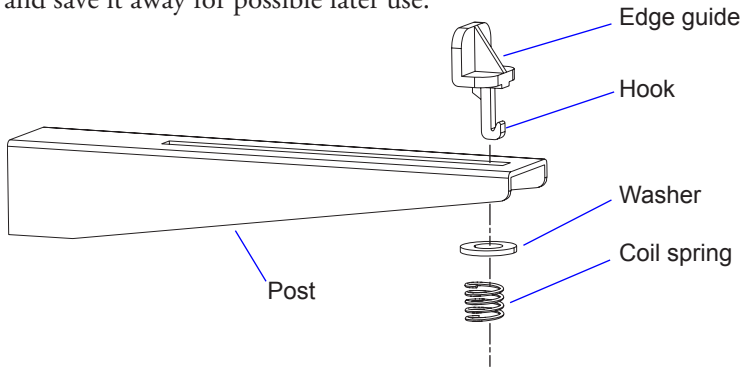

- 3 Insert the hinged high edge guide into the slot in the post (see the next page).
- 4 First fit the washer and then the coil spring from underneath the post to the protruding part of the edge guide and engage the coil spring to the hook (see the next page).
- 5 The high edge guide is hinged to allow media load. Before removing an empty core or loading a roll of media, the guide must be flipped down to a horizontal attitude. Likewise, after loading the media it must be flipped back so it points straight up. Like the low edge guide, it can be adjusted along the post to fit different media widths (see the next page).

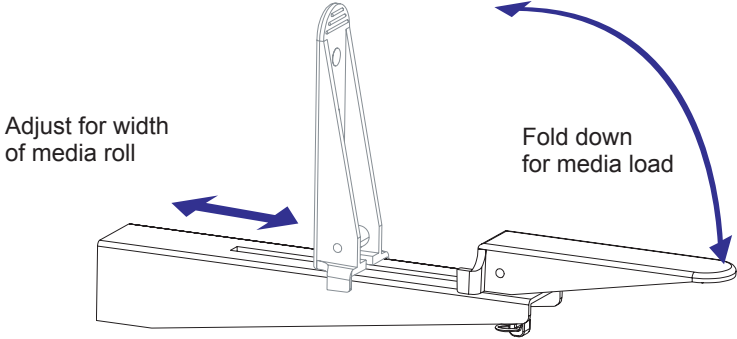
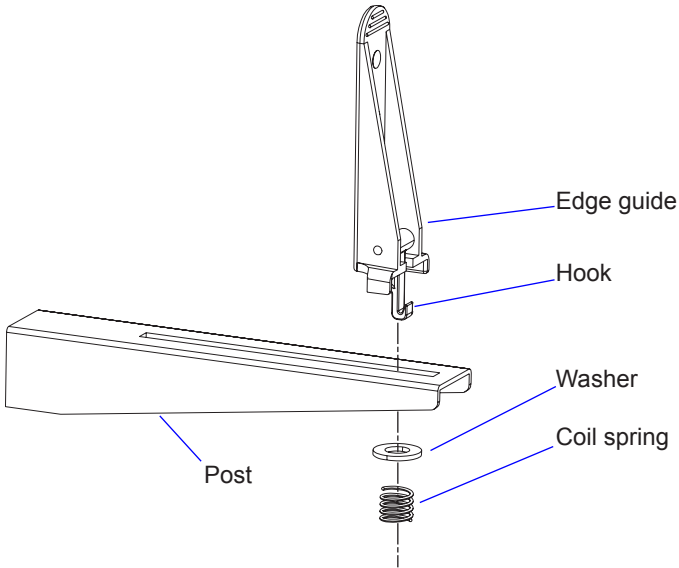

Be careful to flip the high edge guide straight up before closing the side door, or the guide could be damaged.

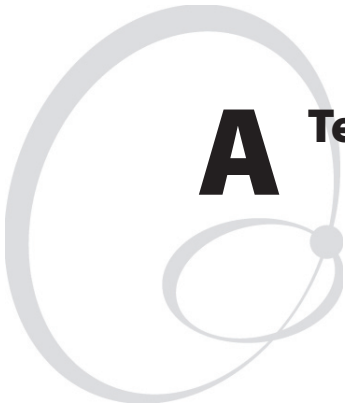

A **Technical Data**

This appendix lists the technical data for the printer. Please note that Intermec reserves the right to change without prior notice and that this information does not represent a commitment on the part of Intermec.

Table of Technical Data

Printing		
Print Technique	Direct Thermal/Thermal Transfer	
Printhead Resolutions	8 dots/mm (203.2 dpi) or 11.81 dots/mm (300 dpi) ¹	
Print Speed (variable)	50.8 to 152.4 mm/sec. (2 to 6 in/sec.) 50.8 to 101.6 mm/sec. (2 to 4 in/sec.)	8 dots/mm 11.81 dots/mm
Print Width	25 to 104 mm (1 to 4.09 in) 25 to 106 mm (1 to 4.17 in)	8 dots/mm 11.81 dots/mm
Print Length (max)	1,270 mm (50 in) 558.8 mm (22 in)	8 dots/mm 11.81 dots/mm
Print Directions	4	
Media		
Media Width	25 to 118.0 mm (1 to 4.65 inches)	
Media Roll Diameter (max)	212 mm (8.35 inches)	
Media Roll Core Diameter	38.1 to 76.2 mm (1.5 to 3 in)	
Media Thickness	60 µm to 250 µm (2.3 to 9.8 mils)	
Transfer Ribbon		
Material	Wax, hybrid, or resin	
Winding	Ink on either inside or outside	
Ribbon Width	30 to 110 mm (1.18 to 4.33 in)	
Ribbon Roll Diameter (outer)	76 mm (2.99 in) equivalent to 450 m (1,471 ft) of ribbon	At ribbon thickness 8 µm
Inner Core Diameter	25.2 to 25.6 mm (1.00 inches)	
Modes of Operation		
Tear-Off (Straight-through)	Yes	
Peel-Off (Self-strip)	Optional	
Cut-Off	Optional	
Firmware		
Operating System	ESim v5.xx	
Latin Fonts	5 resident alphanumeric fonts. Windows bitmap fonts can be downloaded.	

Asian Fonts	Asian fonts can be downloaded: GB 2312-80 Chinese Big5 level 1 & 2 KS X 11001:1992 JIS X0208:12977	Chinese Chinese Korean Japanese
Built-in bar code symbologies (standard)	34	
Physical Measures		
Dimensions (W x L x H)	276 × 454.6 × 283.0 mm (10.85 × 17.9 × 11.2 in)	
Weight (excluding media)	≈ 13 kg (28.7 pounds)	
Environment		
Operating Temperature	+5°C to +40°C (+41°F to +104°F)	
Storage Temperature	-20°C to +50°C (-40°F to +122°F)	
Operating Humidity	30 to 85% non-condensing. Free air	
Storage Humidity	10 to 90% non-condensing. Free air	
Electronics		
Microprocessor	16 bit	
Standard Memory	2MB flash + 2MB DRAM	
Real-time Clock	Yes ¹	Date/time stamp
Power Supply		
AC Voltage	100/240 VAC, 50 to 60 Hz	
Power Consumption	Stand-by 4W; Peak 110W	
Sensors		
Label Gap/Black Mark/ Out of Media	Yes	Moveable, left-aligned
Printhead Lifted	Yes	
Ribbon End	Yes	
Label taken	Yes ¹	
Controls		
Control Lamps	3; Power, Ready, and Error	Bi-color
Display	Yes ¹	Graphic LCD with back-ground light
Control Keys	3; Feed, Pause, and Cancel	
Beeper	Yes	

Appendix A—Technical Data

Data Interfaces		
Serial	1 x RS-232 + 1 x USB	
Parallel	Yes	
Accessories and Options		
Integral Self-strip Unit with Liner Takeup	Option ¹	For peel-off operation
Cutter	Option ¹	
2MB Flash Memory Expansion Module	Option ¹	
Keyboard/Display Unit	Option	
EasyLAN 10 External Ethernet Adapter	Option	

¹/. Versions with graphic display front panel only.

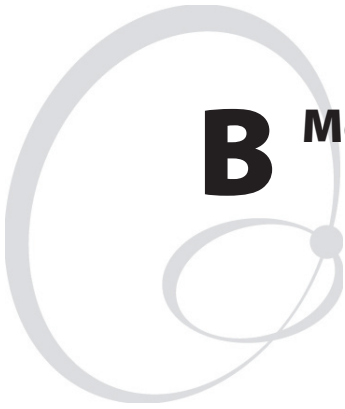

B Media Specifications

This appendix specifies the physical measures for various types of media.

Media Roll Size

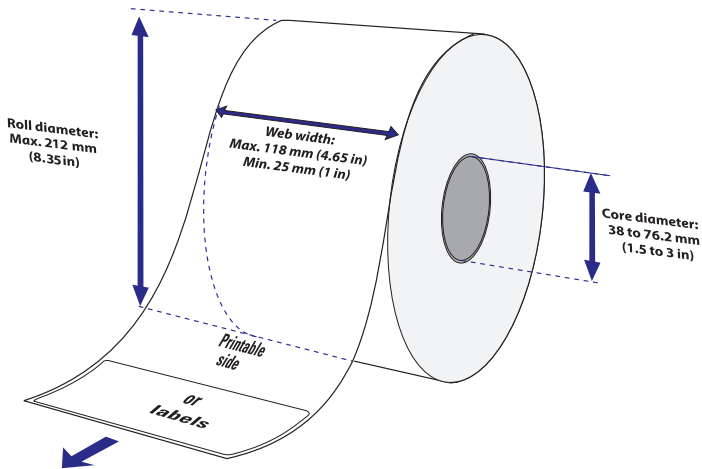

Core

Diameters: 38 to 76.2 mm (1.5 to 3 inches)
Width: Must not protrude outside the media.



The media must be wound up on the core in such a way that the printer can pull the end free.

Internal Roll

Max. diameter: 212 mm (8.35 inches)
Max. width: 118 mm (4.65 inches)
Min. width: 25 mm (1.00 inches)

Thickness: 6 to 250 μm (2.3 to 9.8 mils)

Thicker media may be used, but print quality will be reduced. The stiffness is also important and must be balanced against thickness to maintain print quality. Readjustment of the printhead alignment vs the platen roll may be required (see Chapter 9).

Media rolls to be loaded inside the printer should be wound with the printable side facing outwards.

The media supply must not be exposed to dust, sand, grit, etc. Any hard particles, however small, can damage the printhead.

Media

Non-Adhesive Strip

⇐ a ⇒ Media Width

Maximum: 118.0 mm (4.65 inches)

Minimum: 25.0 mm (1.00 inches)

Paper Type Setup

- Plain paper



Self-Adhesive Strip

⇐ **a** ⇒ **Media Width (including liner)**

Maximum: 118.0 mm (4.65 inches)

Minimum: 25.0 mm (1.00 inches)

⇐ **b** ⇒ **Liner**

The liner must not extend more than a total of 1.6 mm (0.06 inches) outside the face material and should protrude equally on both sides.

⇐ **c** ⇒ **Media Width (excluding liner)**

Maximum: 116.4 mm (4.58 inches)

Minimum: 23.8 mm (0.94 inches)

Paper Type Setup

- Plain paper



Self-Adhesive Labels

← a ⇒ Media Width (including liner)

Maximum: 118.0 mm (4.65 inches)

Minimum: 25.0 mm (1.00 inches)

← b ⇒ Liner

The backing paper must not extend more than a total of 1.6 mm (0.06 inches) outside the labels and should protrude equally on both side.

← c ⇒ Label Width (excluding liner)

Maximum: 116.4 mm (4.58 inches)

Minimum: 23.8 mm (0.94 inches)

← d ⇒ Label Length

Maximum:

8 dots/mm (203.2 dpi) 1270 mm (50 inches)

11.81 dots/mm (300 dpi) 558.8 mm (22 inches)

Minimum:

8 dots/mm (203.2 dpi) 5 mm (0.2) inches)

11.81 dots/mm (300 dpi) 5 mm (0.2 inches)

← e ⇒ Label Gap

Maximum: 26.0 mm (1.02 inches)

Recommended: 3.0 mm (0.12 inches)

Minimum: 1.2 mm (0.05 inches)

The Label gap sensor must be able to detect the extreme front edges of the labels. It can be moved 0 to 57 mm (0 to 2.24 inches) from the inner edge of the media (see Chapter 9).

Paper Type Setup

- Gap paper

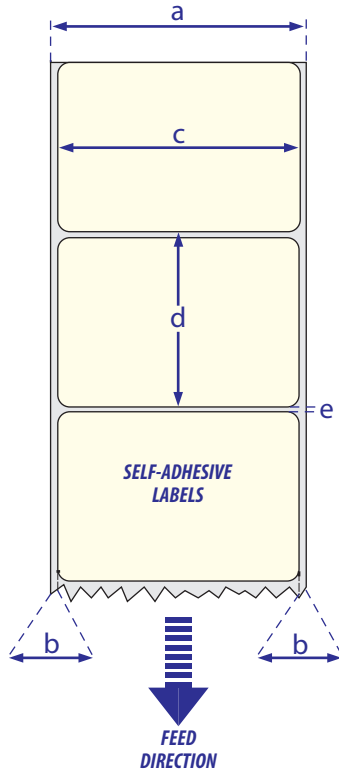

Tickets with Gaps

← a ⇒ Media Width

Maximum:	118.0 mm (4.65 inches)
Minimum:	25.0 mm (1.00 inches)

← b ⇒ Copy Length

Maximum:	
8 dots/mm (203.2 dpi)	1270 mm (50 inches)
11.81 dots/mm (300 dpi)	558.8 mm (22 inches)

Minimum:	
8 dots/mm (203.2 dpi)	5 mm (0.2) inches
11.81 dots/mm (300 dpi)	5 mm (0.2) inches

← c ⇒ Detection Position

Variable:	0 to 57 mm (0 to 2.24 inches)
-----------	-------------------------------

← d ⇒ Detection Slit Length

The length of the detection slit (excluding corner radii) must be minimum 2.5 mm (0.10 inches) on either side of the detection position (e).

← e ⇒ Detection Slit Height

Maximum:	26.0 mm (1.02 inches)
Recommended:	3.0 mm (0.12 inches)
Minimum:	1.2 mm (0.05 inches)

Paper Type Setup

- Gap paper



Note: Do not allow any perforation to break the edge of the media as this may cause the media to split and jam the printer.

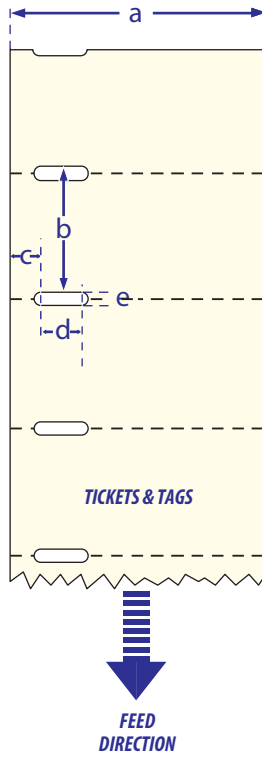

Tickets with Black Mark

← a ⇒ Media Width

Maximum:	118.0 mm (4.65 inches)
Minimum:	25.0 mm (1.00 inches)

← b ⇒ Copy Length

Maximum:	
8 dots/mm (203.2 dpi)	1270 mm (50 inches)
11.81 dots/mm (300 dpi)	558.8 mm (22 inches)
Minimum:	
8 dots/mm (203.2 dpi)	10 mm (0.39) inches)
11.81 dots/mm (300 dpi)	10 mm (0.39) inches)

← c ⇒ Detection Position

Variable:	0 to 57 mm (0 to 2.24 inches)
-----------	-------------------------------

← d ⇒ Black Mark Width

The detectable width of the black mark should be at least 5.0 mm (0.2 inches) on either side of the LSS detection point.

← e ⇒ Black Mark Length

Maximum:	25 mm (0.98 inches)
Common:	5 mm (0.2 inches)
Minimum:	3 mm (0.12 inches)

← f ⇒ Black Mark Y-Position

It is recommended that you place the black mark as close to the front edge of the ticket as possible and use a negative Stop Adjust value to control the media feed, so the tickets can be properly torn off.

Paper Type Setup

- Black mark



Note: Preprint that may interfere with the detection of the black mark should be avoided.



Note: The black mark should be non-reflective carbon black on a whitish background. Do not allow any perforations to break the edge of the media as this may cause the media to split and jam the printer.

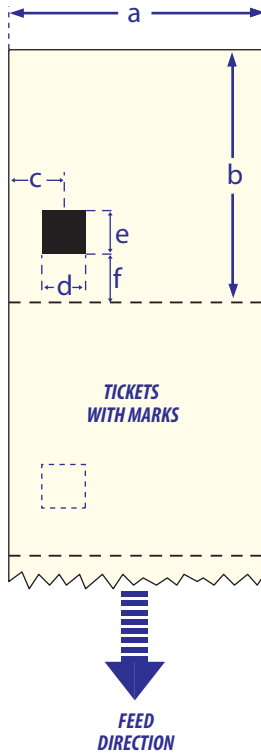

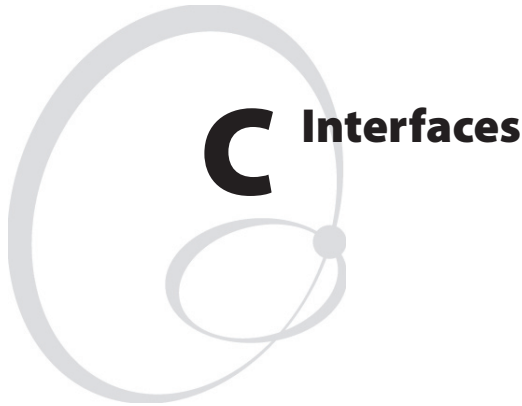

C Interfaces

This appendix describes the interface connectors found on the printer's rear plate. It covers the following topics:

- RS-232 interface
- USB interface
- Parallel Interface

RS-232 Interface

Protocol

Default setup:

Baud rate: 9600
Char. Length 8 bits
Parity: None
Stop bits: 1
Handshaking: XON/XOFF and RTS/CTS

To change the RS-232 interface settings, see Chapter 5, “Printing.”

Signals on printer's serial port:

DB-9	Signal	Meaning
1		External +5V DC Max 500mA, permanently enabled
2	TXD	Transmit data
3	RXD	Receive data
4		
5	GND	Ground
6		
7	CTS	Clear to send
8	RTS	Request to send
9		

Interface Cable

Computer end: Depends on computer model

Printer end: DB-9pin plug

USB Interface

This printer supports USB v1.1 (also called USB 2.0 full speed). To use the USB interface for printing from a PC, you need a special Intermec USB printer driver installed in your PC.

The printer is a so called “self-powered device.” We recommend that you only connect one printer to each USB port on the host, either directly or via a hub. Other devices, like a keyboard and a mouse, can be connected to the same hub. If you need to connect more than one Intermec USB printer to a host, you should use different USB ports.

Using a USB Class A/B cable, connect the Class A plug to your PC or hub and the Class B plug to your printer.

There is no communication setup for the USB port.

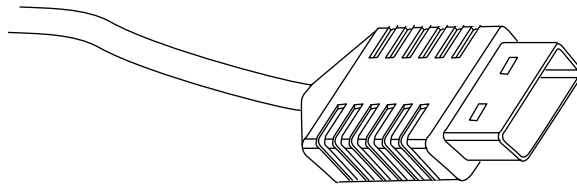

*USB Class A connector.
Connect to PC or hub.*

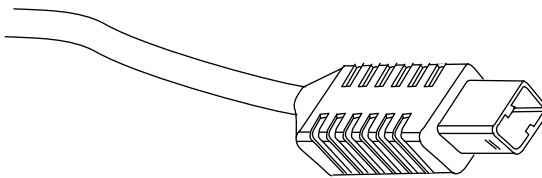

*USB Class B connector.
Connect to USB receptacle on the printer's rear plate.*

Parallel Interface

Handshake: DSTB connects to the printer, BUSY connects to the host

Interface cable: Parallel cable compatible to IBM PC

Pinout Description

Pin	Function	Transmitter	Comment
1	/Strobe	host	
2-9	Data 0-7	host	
10	/Acknowledge	printer	
11	Busy	printer	
12	/Paper empty	printer	
13	/Select	printer	
14-16	Not connected		
17	Chassis ground		
18	External +5V DC		Max 500mA, permanently enabled
19-30	Signal ground		
31	Not connected		
32	/ERROR	printer	
33	Signal ground		
34-36	Not connected		



D Firmware Upgrading

This appendix describes how to upgrade the printer with a new firmware version.

Requirements

To upgrade the printer's firmware via a cable connection from a PC running MS Windows, you will need the following:

- The Intermec EasyCoder PD4 Config Tool. This is a free software running under Microsoft Windows¹. It makes it possible to download various firmware version either directly to the printer or to a memory cartridge. It also supports font downloading and memory partitioning. The Config Tool supports seven languages and comes with a comprehensive on-line help in English.
- An upgrading file (.ufz). The Intermec EasyCoder PD4 Config Tool comes with a collection of firmware upgrading files. New files can be downloaded from the Intermec Web site (<http://www.intermec.com>) and should be located in the subfolder "Firmware."
- A host computer running Microsoft Windows with a parallel, USB, or RS-232 connection to the EasyCoder PD4. (Parallel or USB connections are recommended.)

Instructions

- 1 Install the Intermec EasyCoder PD4 Config Tool in your PC.
- 2 Run the **PD4Conf.exe** program.
- 3 Set up the parameters for the firmware download. Use the on-line help for instructions.
- 4 Start the Firmware download wizard and follow the instructions on the screen.

¹/ Supported versions of MS Windows: Windows 95, Windows 98, Windows Me, Windows 2000, and Windows XP.



Intermec Technologies Corporation

Corporate Headquarters
6001 36th Avenue West
Everett, WA 98203
U.S.A.

tel 425.348.2600

fax 425.355.9551

www.intermec.com

EasyCoder PD4 User's Guide



1-960614-01

Free Manuals Download Website

<http://myh66.com>

<http://usermanuals.us>

<http://www.somanuals.com>

<http://www.4manuals.cc>

<http://www.manual-lib.com>

<http://www.404manual.com>

<http://www.luxmanual.com>

<http://aubethermostatmanual.com>

Golf course search by state

<http://golfingnear.com>

Email search by domain

<http://emailbydomain.com>

Auto manuals search

<http://auto.somanuals.com>

TV manuals search

<http://tv.somanuals.com>