

The Intermec logo is displayed in a bold, blue, sans-serif font. It is positioned to the left of a square icon containing a stylized white circular graphic with a blue square in the center. The entire logo and icon are set against a background of overlapping light blue circles and lines, resembling an orbital or network diagram.

Intermec



User's Manual



**PK80 Series
80-Column Printer**

Intermec Technologies Corporation

Corporate Headquarters	Technical Communications Department
6001 36th Ave. W.	550 Second Street SE
Everett, WA 98203	Cedar Rapids, IA 52401
U.S.A.	U.S.A.

www.intermec.com

The information contained herein is proprietary and is provided solely for the purpose of allowing customers to operate and service Intermec-manufactured equipment and is not to be released, reproduced, or used for any other purpose without written permission of Intermec.

Information and specifications contained in this document are subject to change without prior notice and do not represent a commitment on the part of Intermec Technologies Corporation.

© 2003-2005 by Intermec Technologies Corporation. All rights reserved.

The word Intermec, the Intermec logo, Norand, ArciTech, CrossBar, Data Collection Browser, dcBrowser, Duratherm, EasyCoder, EasyLAN, Enterprise Wireless LAN, EZBuilder, Fingerprint, i-gistics, INCA (under license), InterDriver, Intermec Printer Network Manager, IRL, JANUS, LabelShop, Mobile Framework, MobileLAN, Nor*Ware, Pen*Key, Precision Print, PrintSet, RoutePower, TE 2000, Trakker Antares, UAP, Universal Access Point, and Virtual Wedge are either trademarks or registered trademarks of Intermec Technologies Corporation.

Throughout this manual, trademarked names may be used. Rather than put a trademark (™ or ®) symbol in every occurrence of a trademarked name, we state that we are using the names only in an editorial fashion, and to the benefit of the trademark owner, with no intention of infringement.

There are U.S. and foreign patents pending.

Bluetooth is a trademark of Bluetooth SIG, Inc., U.S.A.

Document Change Record

This page records changes to this document. The document was originally released as Revision A.

Revision	Date	Description of Change
B	05/2003	Updated information about Bluetooth configuration
C	10/2003	Added Easy Print commands, default and downloadable fonts.
D	04/2004	Added printer behavior information to Chapter 2, "Operations." Added additional downloadable fonts to Appendix B, "Fonts." Updated printer paper specifications in Chapter 1, "Introduction." Added Appendix C, "Graphics Printing."
E	12/2004	Added additional setting page length commands to Appendix C, "Graphics Printing."
F	02/2005	Updated Chapter 4, "Troubleshooting," to include the latest self-test information.

Contents

Before You Begin	ix
Safety Summary	ix
Do not repair or adjust alone	ix
First aid	ix
Resuscitation	ix
Energized equipment	ix
Safety Icons	x
Global Services and Support	xi
Warranty Information	xi
Web Support	xi
Telephone Support	xi
Who Should Read this Manual?	xii
Related Documents	xii

1 Introduction 1

About the Printer	2
Cables	3
Hinges on Printer Cover	3
Paper	4
Material Breakdown	4
Caliper Breakdown	5
Printer Dimensions	5
Remote Connections	6
User Panel	6
Forward and Reverse Buttons	6
Radio Button	7
Vehicle Battery	7
Specifications	8
Inside Sales	9
What's New	10

2 Operation 11

Check List	12
Open the Printer	12
Install the Ribbon Cartridge	13
Adjust the Print Head Gap	14

Contents

Fill the Paper Tray	15
Fill the Compact Paper Tray	15
Fill the Dashboard Mount Paper Tray	17
Load Paper into Printer	19
Position the Paper	19
Adjust the Pinfeed Holders	20
Set the Paper	21
Printer Behavior	22
Expectations	22
Indicators	22
Printer Runs Out of Paper	23
Printer Head Jams	23
Print Job Status Report	24
Timing Out	24
3 Maintenance	25
Operation Guidelines	26
General Cleaning	27
Outside Cleaning	27
Inside Cleaning	28
Old Ribbon Cartridge Removal	29
Mask Spring Cleaning	30
4 Troubleshooting	33
Check the Power Source	34
Large Print Jobs	34
Printer Cold-Boot	34
Self-Test	34
Sample Self-Test	36
Report Failure	37
Possible Printer Problems	38
Communications with Host Computer	39

Communications Pin-Out Configurations	40
A Commands	43
Commands	44
Bluetooth Wireless Configuration Commands	44
Easy Print Commands	45
Query Commands	46
Interpreting the Reply to a Query	46
ESC{ST?} — Status	47
ESC{CF?} — Configuration	48
ESC{VR?} — Version	49
ESC{MY?} — Memory	50
ESC{PH?} — Print Head	51
ESC{FN?} — Fonts	52
PK80F Control Sequences	53
Radio Queries	55
Bluetooth QUERY ESC{BL?}	55
B Fonts	57
Default Fonts	58
Downloadable Fonts	58
C Graphics Printing	59
Graphics Overview	60
Pin Labels	60
Graphics Command Format	60
Column Reservation Numbers	60
Graphics Mode	61
Eight-Pin Graphics Modes	61
Nine-Pin Graphics Modes	61
ESC K — Select Single-Density Graphics Mode	61
ESC L — Select Low-Speed Double-Density Graphics Mode	62
ESC Y — Select High-Speed Double-Density Graphics Mode	62
ESC Z — Select Low-Speed Quadruple-Density Graphics Mode	62
ESC ^ — Select 9-Pin Graphics Mode	63
ESC * — Select Graphics Mode	63
ESC ? — Reassign Graphics Mode	64
ESC + — Print Character Graphics	64
ESC t — Print Character Graphics	64

Contents

Line Spacing	65
ESC 0 — Select 1/8-inch Line Spacing	65
ESC 1 — Select 7/72-inch Line Spacing	65
ESC A — Select n/72-inch Line Spacing	65
ESC 2 — Select 1/6-inch Line Spacing	65
ESC 3 — Select n/216-inch Line Spacing	65
Page Length	66
Set Page Length (lines)	66
Set Page Length (inches)	66
User-Defined Characters	67
ESC : — Copy ROM to RAM	67
ESC & — Define User-Defined Characters	67
ESC % — Select User-Defined Set	68
ESC 6 — Enable Printing of Codes 128–159	68
ESC 7 — Cancel Printing of Codes 128–159	69
ESC I — Printable Code Area Expansion	69

Before You Begin

This section provides you with safety information, technical support information, and sources for additional product information.

Safety Summary

Your safety is extremely important. Read and follow all warnings and cautions in this document before handling and operating Intermec equipment. You can be seriously injured, and equipment and data can be damaged if you do not follow the safety warnings and cautions.

Do not repair or adjust alone

Do not repair or adjust energized equipment alone under any circumstances. Someone capable of providing first aid must always be present for your safety.

First aid

Always obtain first aid or medical attention immediately after an injury. Never neglect an injury, no matter how slight it seems.

Resuscitation

Begin resuscitation immediately if someone is injured and stops breathing. Any delay could result in death. To work on or near high voltage, you should be familiar with approved industrial first aid methods.

Energized equipment

Never work on energized equipment unless authorized by a responsible authority. Energized electrical equipment is dangerous. Electrical shock from energized equipment can cause death. If you must perform authorized emergency work on energized equipment, be sure that you comply strictly with approved safety regulations.

Safety Icons

This section explains how to identify and understand dangers, warnings, cautions, and notes that are in this manual. You may also see icons that tell you when to follow ESD procedures and when to take special precautions for handling optical parts.



A warning alerts you of an operating procedure, practice, condition, or statement that must be strictly observed to avoid death or serious injury to the persons working on the equipment.

Avertissement: Un avertissement vous avertit d'une procédure de fonctionnement, d'une méthode, d'un état ou d'un rapport qui doit être strictement respecté pour éviter l'occurrence de mort ou de blessures graves aux personnes manipulant l'équipement.



A caution alerts you to an operating procedure, practice, condition, or statement that must be strictly observed to prevent equipment damage or destruction, or corruption or loss of data.

Attention: Une précaution vous avertit d'une procédure de fonctionnement, d'une méthode, d'un état ou d'un rapport qui doit être strictement respecté pour empêcher l'endommagement ou la destruction de l'équipement, ou l'altération ou la perte de données.



Note: Notes either provide extra information about a topic or contain special instructions for handling a particular condition or set of circumstances.

Global Services and Support

Warranty Information

To understand the warranty for your Intermecc product, visit the Intermecc web site at www.intermec.com and click **Service & Support**. The Intermecc Global Sales & Service page appears. From the **Service & Support** menu, move your pointer over **Support**, and then click **Warranty**.

Disclaimer of warranties: The sample code included in this document is presented for reference only. The code does not necessarily represent complete, tested programs. The code is provided “as is with all faults.” All warranties are expressly disclaimed, including the implied warranties of merchantability and fitness for a particular purpose.

Web Support

Visit the Intermecc web site at www.intermec.com to download our current manuals in PDF format. To order printed versions of the Intermecc manuals, contact your local Intermecc representative or distributor.

Visit the Intermecc technical knowledge base (Knowledge Central) at intermec.custhelp.com to review technical information or to request technical support for your Intermecc product.

Telephone Support

These services are available from Intermecc Technologies Corporation.

Service	Description	In the U.S.A. and Canada call 1-800-755-5505 and choose this option
Factory Repair and On-site Repair	Request a return authorization number for authorized service center repair, or request an on-site repair technician.	1
Technical Support	Get technical support on your Intermecc product.	2
Service Contract Status	Inquire about an existing contract, renew a contract, or ask invoicing questions.	3
Schedule Site Surveys or Installations	Schedule a site survey, or request a product or system installation.	4
Ordering Products	Talk to sales administration, place an order, or check the status of your order.	5

Outside the U.S.A. and Canada, contact your local Intermecc representative. To search for your local representative, from the Intermecc web site, click **Contact**.

Who Should Read this Manual?

This manual provides you with information about the features of the PK80 Series 80-Column Printer, and how to install, configure, operate, maintain, and troubleshoot the printer.

Related Documents

This table contains a list of related Intermec documents and their part numbers.

Document Title	Part Number
<i>PK80 Series 80-Column Printer Installation Instructions</i>	962-018-022
<i>PK80F 80-Column Printer Quick Start Guide</i>	962-018-021

The Intermec web site at www.intermec.com contains many of our documents that you can download in PDF format.

To order printed versions of the Intermec manuals, contact your local Intermec representative or distributor.



1 Introduction

The PK80 Series 80-Column Wireless Printer is used in the route accounting industry to produce high-quality customer invoices, receipts, load reports, transfers, and other documents. A unique “sleep” feature saves energy when the printer is not printing, eliminating the ON/OFF switch. Data input is normally provided by mobile computers.

About the Printer

The Fixed Mount Printer (PK80F) can hang on a wall, on a mounting plate secured to a wall, or secured directly to a wall. Mobile computers communicate with this printer through a wireless radio or a wired serial connection. There is no internal paper tray, thus paper is loaded from a separate dashboard mount, compact paper tray, or a box. The printer mechanism is permanently attached inside the printer.

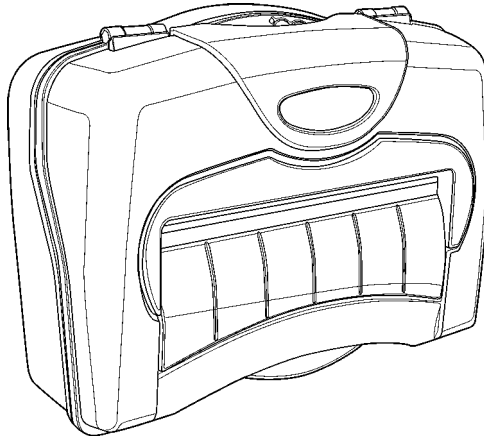

Cables

Communications to the printer is centered around radio technology, such as a Bluetooth PAN (Personal Area Network) radio module. This will allow for new vehicle configurations.

The Fixed Mount Printer has a 12-volt dc power cable at the bottom of the printer, which connects the printer to a power source, such as the vehicle battery.

The printer also communicates with an Intermecc[®] 700 Series Mobile Computer through an RS-232 DB25-pin data communications cable also found on the bottom of the printer.

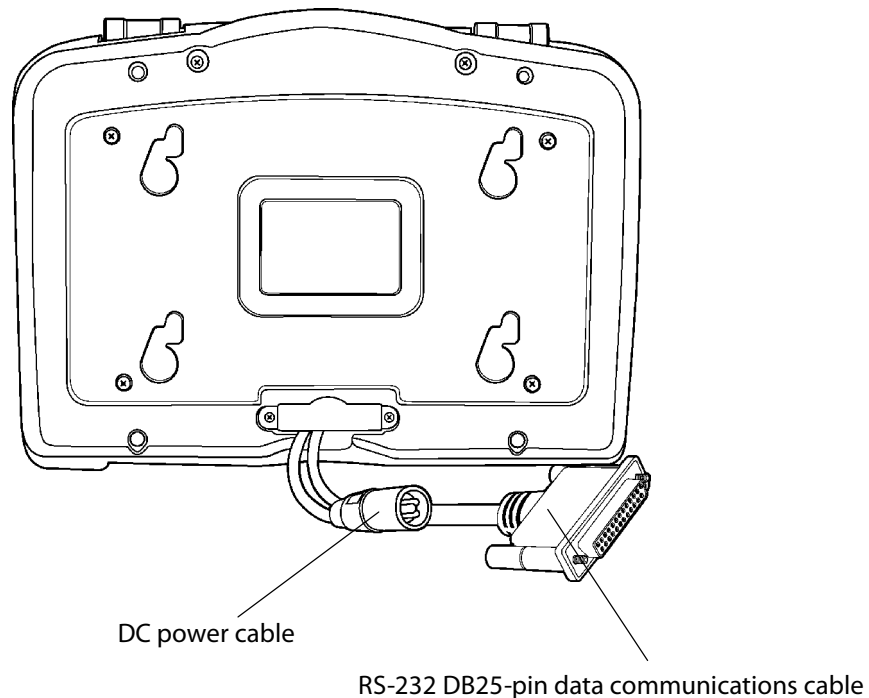

Hinges on Printer Cover

All printer covers are hinged to the printer. These hinges have a tension screw (turn clockwise to tighten, turn counterclockwise to loosen), should you need to adjust them.

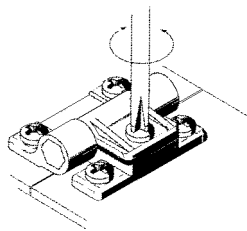

Paper



Use of paper that matches the following specifications ensures optimum PK80 performance. Variation from these specifications, use of aged paper, or use of paper exposed to elements such as dirt or humidity may cause printing problems.

The printer works with 1–3 ply carbonless paper that is single-edge glued and designed for sprocket feed. Standard paper size is 8.5 x 11” or 8.5 x 12” (241 x 305 mm international). Use 3-ply forms up to a maximum of 0.009 inch (0.23 mm) thick.

A soft, flexible, rubber type cement applied to one perforation strip only is preferred. The resultant lamination should wrap around a 1-1/4 inch diameter roll without curl or wrinkle.

Material Breakdown

The following tables show the material broken down per ply:

14# CBF (Carbonless Back and Front)

	Target	Under	Over
Basis Weight	14#	13.3	14.7
Caliper	2.9	2.6	3.2
Moisture	5.0	4.0	6.0
Smoothness (RS)	165	110	230
Smoothness (CB)	270	220	320
Brightness (Wht)	88	86	90
Colors available: White, Canary, Pink, Goldenrod, Blue, Green			

15# CF (Carbonless Front)

	Target	Under	Over
Basis Weight	15#	14.43	15.8
Caliper	3.0	2.5	3.2
Moisture	5.0	4.0	6.0
Smoothness (RS)	140	100	180
Smoothness (CF)	140	100	180
Brightness (Wht)	85	84	86
Colors available: White, Canary, Pink, Goldenrod, Blue, Green			

16# CB (Carbonless Back)

	Target	Under	Over
Basis Weight	16#	15.2	16.8
Caliper	3.3	2.8	3.8
Moisture	5.7	4.2	6.7
Smoothness (RS)	180	120	270
Smoothness (CB)	270	220	320
Brightness (Wht)	86	84	88
Opacity (Wht)	81	78.5	82

20# OCR Laser Bond

	Target	Under	Over
Basis Weight	20#	15.2	16.8
Caliper	4.0	3.8	4.2
Moisture	3.8	4.7	5.0
Smoothness	140	100	170
Brightness (Wht)	94	82	N/A*
Opacity (Wht)	85	84	N/A
* Not Applicable			

Caliper Breakdown

The following information show the caliper of forms broken down per ply:

1-Ply (20#)

Targeted: 4.0

Maximum: 4.2

2-Ply (15# and 16#)

Targeted: 6.3

Maximum: 7.0

3-Ply (14#, 15#, and 16#)

Targeted: 9.2

Maximum: 10.2

Printer Dimensions

See the *PK80 Series 80-Column Printer Installation Instructions* for Fixed Mount Printer assembly dimensions. Below are the width, length, and depth dimensions for the Fixed Mount Printer.

Width	Length	Depth
10.25" W	14.25" L	5.00" H
(26.04 cm)	(36.20 cm)	(12.70 cm)

Remote Connections

A printer and a mobile computer, using the Personal Area Network (PAN) radio, can operate while up to 30 feet (10 meters) apart.

User Panel

The printer user panel is located in the center top of the printer and has three buttons and two Light-Emitting Diodes (LEDs).

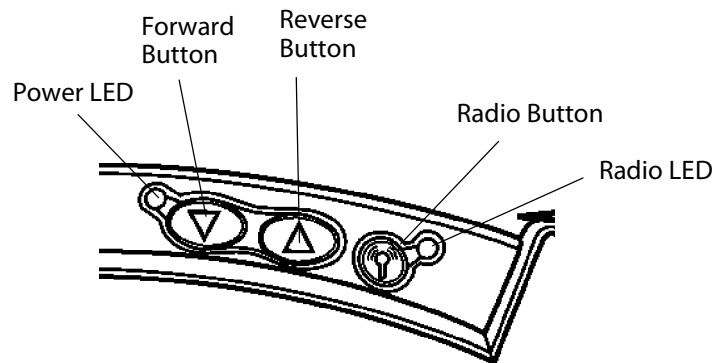

Forward and Reverse Buttons

Use the Forward and Reverse buttons as follows:

Forward (Left) Button

- Press this button to power on the printer.
- Press this button to feed one line.
- Press and hold this button longer to feed up to five lines, one line at a time.
- Press and hold this button longer than five feed lines to do a Form Feed, which moves the paper to the top of the next page, or form. Press this button again during a Form Feed to stop the paper feed.
- Press and hold this button longer than a Form Feed to perform a self-test. See Chapter 4, "Troubleshooting," for more information about this test.
- Press this button any time during a printing job to cancel the current print job. The print buffer is flushed, all automatic reporting is cancelled, and the printer is ready to print again.
- When there is a paper out, press this button to clear the paper out mode. Insert the paper, then continue to press this button to feed the paper into the printer.

Reverse (Right) Button

- Press this button to power on the printer.
- Press and hold this button to do a Back Feed, which pulls the paper back into the printer line-by-line.

Both Forward and Reverse Buttons

Press both buttons to power off the printer. The current print buffer is flushed and all automatic reporting is cancelled.

Power LED

The power (left) LED shows a steady green when the power is plugged in and when the printer is awake after coming out of a sleep mode.

Radio Button

Press the third button, the **Radio Button**, to toggle the radio on or off.

- If the button is pressed when the RF power is off, then the printer emits one short beep before turning on the RF power.
- If this button is pressed when the RF power is on, the printer emits two short beeps before turning off the RF power.

Single Color (Blue) Radio LED

The single-color (blue) radio LED indicator shows the current status of the RF power for this printer as follows:

Printer State	Radio State	Radio Power State
Asleep	Off	Off
Awake	Off	Off
Asleep	Momentary flash at 1 every 5 seconds	On
Awake	On	On

Single Color (Green) Power LED

The single color (green) LED indicator shows the current status of the printer power as follows:

Printer State	Color LED and Meaning
Asleep	Off
Awake	Green

Vehicle Battery

Power is provided to the printer through a cable permanently installed in the vehicle. See “*Inside Sales*” for ordering information and part numbers.

Specifications



Note: Various print fonts do affect the print speed.

Print Speed:	230 cps
Weight:	
Fixed Mount Printer:	11.15 lbs (5.06 kg)
Mounting plate:	7.4 lbs (3.36 kg)
Compact paper tray:	5.85 lbs (2.66 kg)
Dashboard mount:	25.95 lbs (11.76 kg)
Temperature:	
Operating:	-4° to 140° F (-20° to 60° C)
Storage:	-22° to 149° F (-30° to 65° C)
Humidity:	
Noncondensing:	77° to 140° F (25° to 60° C) at 90% R.H.
Low condensation:	14° F (-10° C) @ 0% R. H. to
High condensation:	140° F (60° C) @ 90% R.H.
Altitude:	
Operating:	-100 to 5000 meters
Storage:	15,000 meters
Electrical:	
Voltage:	12 volts dc (nominal)
Current:	100 mA (sleep mode with no charge)
Vibration:	12.5 GRMS for 6 hours @ -31° to 158° F (-35° to 70° C)
ESD:	Level 4 (15 kV noncontact and 8 kV contact)

Inside Sales

Contact Inside Sales at 1-800-255-6292 for these supplies:

Cables:	
4' power cable	P/N: 226-215-001
8' Battery cable	P/N: 206-875-002
16' Battery cable	P/N: 206-875-006
22' Battery cable	P/N: 206-875-009
"Y" power cable	P/N: 226-325-001
Y-data DB9 Pwr 3P to DB25	P/N: 321-582-001
Cleaning solutions:	
MICRO-CLEAN II	P/N: 901-438-001
Guide Shaft Cleaner	P/N: 901-439-001
Paper:	
1-ply:	P/N: 816-027-111
2-ply:	P/N: 816-027-012
3-ply:	P/N: 816-027-013
Ribbon cartridges with:	
Black ribbon:	P/N: 805-060-001
Purple ribbon:	P/N: 805-060-002

What's New

The following information was added since the last release of this publication:

- Updated self-test information in Chapter 4, “*Troubleshooting*.”

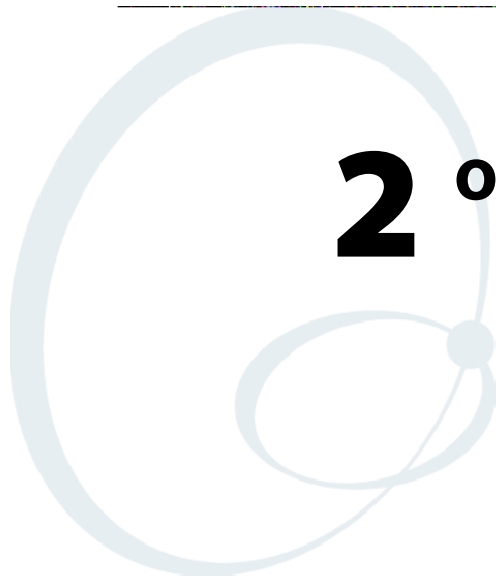

2 **Operation**

This chapter provides instructions how to set up the PK80 Series 80-Column Printer for the first time and lists some common printer behavior.

Check List

Make sure the following tasks are done:

- Printer is unpacked.
- Packaging material is removed from around the printer. Save the box and materials for future use, such as servicing, relocations, etc.
- Twist tie is removed from the print head.
- Power cable is hooked up to the vehicle battery or power source.
- Printer is mounted in the vehicle.

The following tasks must be done. *Specific instructions for these tasks are described on the pages given:*

- 1 Install the ribbon cartridge (*page 13*).
- 2 Load the paper into the paper tray (*page 15*).
- 3 Feed the paper into the printer (*starting on page 19*).



Note: Complete these tasks **before** starting any printer operations.

Open the Printer

To open the PK80 Series Printer, place your hands on both corners, fingers under the lips, and lift upwards. To close, simply press down on the same areas.

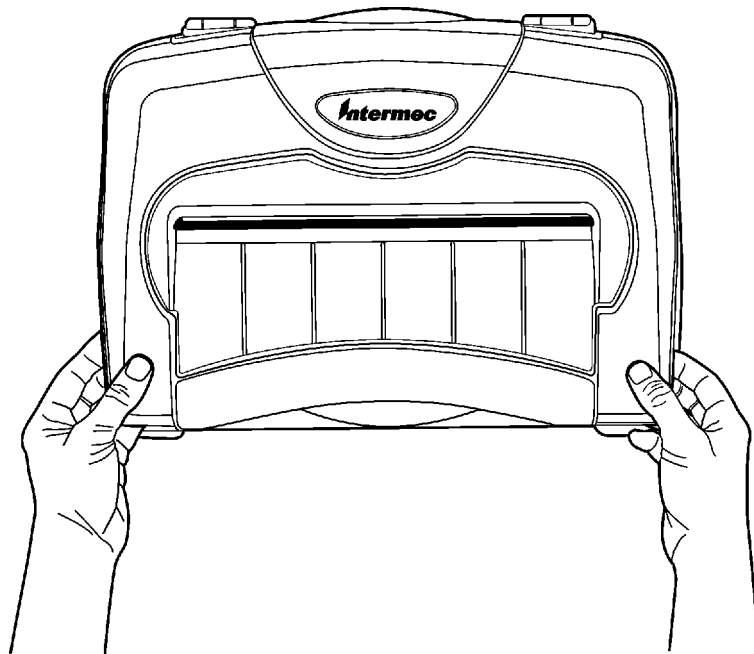

Install the Ribbon Cartridge



Note: Additional ribbon cartridges are sold separately. See “*Inside Sales*” in Chapter 1 for ordering information and part numbers.

Ensure that the ribbon cartridge is in the printer and is fully seated (cartridge makes a distinct “snap” or “click”) with the visible portion of the ribbon straight and even before you do any printing.

- 1 Turn the ribbon advance knob (in the direction of the raised arrows) to remove any slack in the ribbon.
- 2 Squeeze the ribbon cartridge locking tab into the cartridge, then lower the cartridge over the print head.
- 3 Lower the tab side of the cartridge until it clicks.
- 4 Release the tab and press *down* on the arrow to fully seat the ribbon cartridge (tab clicks *outward*).
- 5 Turn the ribbon advance knob (*follow raised arrows*) to align the ribbon in the front of the print head.

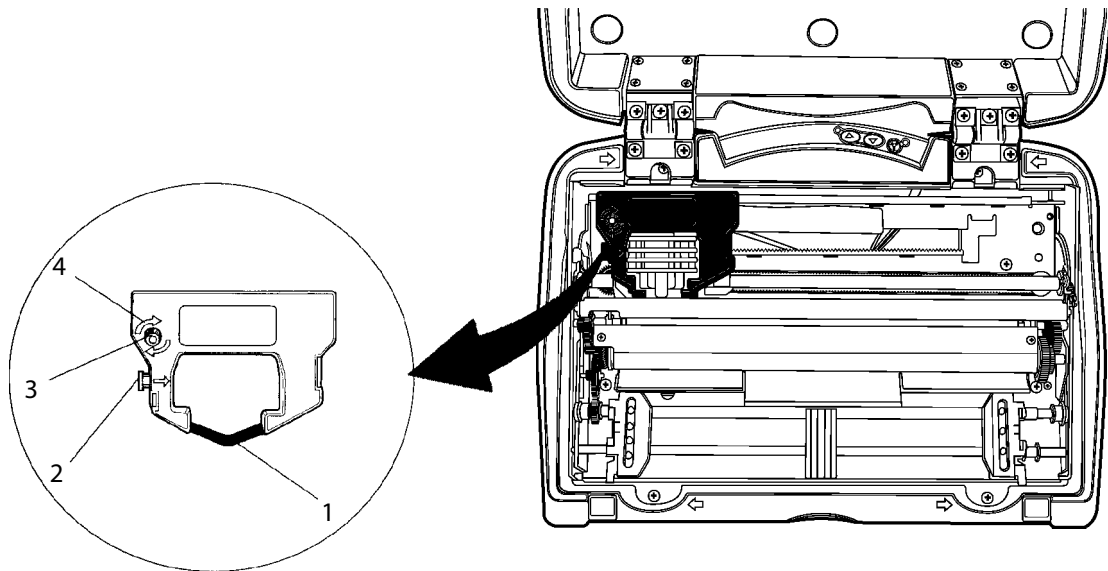

- 1 Ribbon
- 2 Locking tab
- 3 Advance knob
- 4 Tightens ribbon

Adjust the Print Head Gap

When the printer is powered on or awakened, the print head will find “home” by advancing away from home, then returning to home, or by returning to home if starting from another location, such as where it stopped when the last printing job was complete.

When printing is complete, the print head remains where it stopped with a low hold energy applied to the print head. Further printing activity begins from this stopped point. If there is no activity after ten seconds, the print head returns to its home position and is no longer held in place. If the print head is moved from this position, the printer will relocate to its home position before printing again.

The head gap adjuster is near the printer mechanism on the side *opposite the green thumb wheel*. The print head adjuster has five notches between the print head and the platen for different paper thicknesses.

Verify the thickness of the paper loaded into the printer.

- If you are using single-sheet forms, set the head gap adjuster to the third notch *away from the paper*.
- If you are using multiple-sheet forms (2-ply or 3-ply), set the head gap adjuster to the fourth notch *away from the paper*.
- If you experience frequent head jams, set the head gap adjuster to the fifth notch *away from the paper*. This may stop the head jams.
- If the 2-ply and 3-ply paper have light printing, setting the gap adjuster to a closer setting will darken the print.

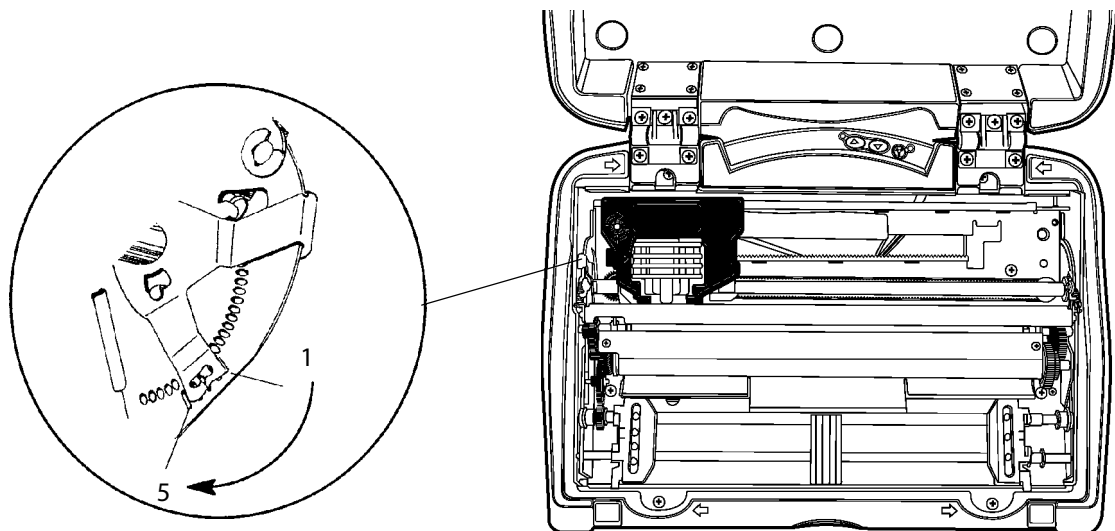

This illustrating shows the print head adjuster set on its third notch.

Fill the Paper Tray



Note: Do not exceed the recommended amounts of paper quantity or thickness. When loading multiple-sheet paper, be sure to have the original faced up, with the leading edge towards the rear of the printer.

The Fixed Mount Printer can load paper from a compact paper tray (*next paragraph*), a dashboard mount paper tray (*page 17*), or a separate box.

Fill the Compact Paper Tray

The compact paper tray is designed to hold 6.25" x 8.5" forms. Larger forms will have to be curved to fit in the paper tray box. The following instructions are written for 8.5" x 11" forms.

If you are using a compact paper tray to feed paper into the Fixed Mount Printer, then do the following to load paper into that tray:

- 1 Hold a stack of paper, *up to 2.5 inches (6 cm) thick*, with the original on top. Bend the paper to fit the paper tray.

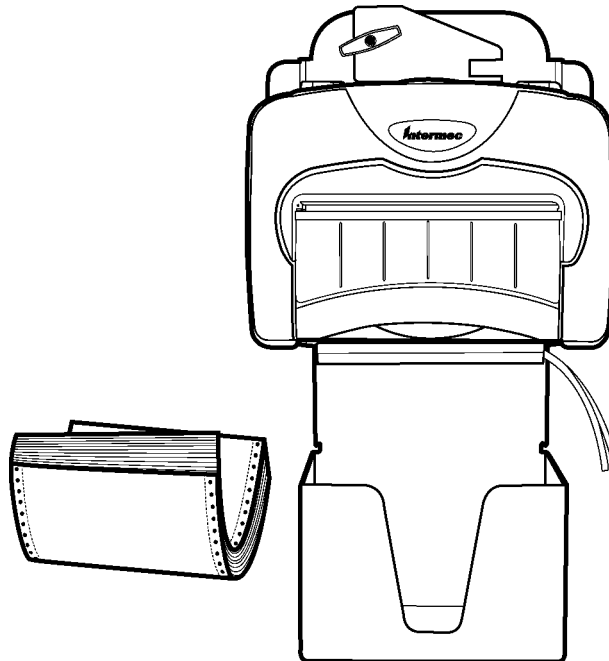

- Using the open area of the paper tray, lower the paper into the paper tray, then pull out your hand. The top of the form should be facing up and be nearest you.

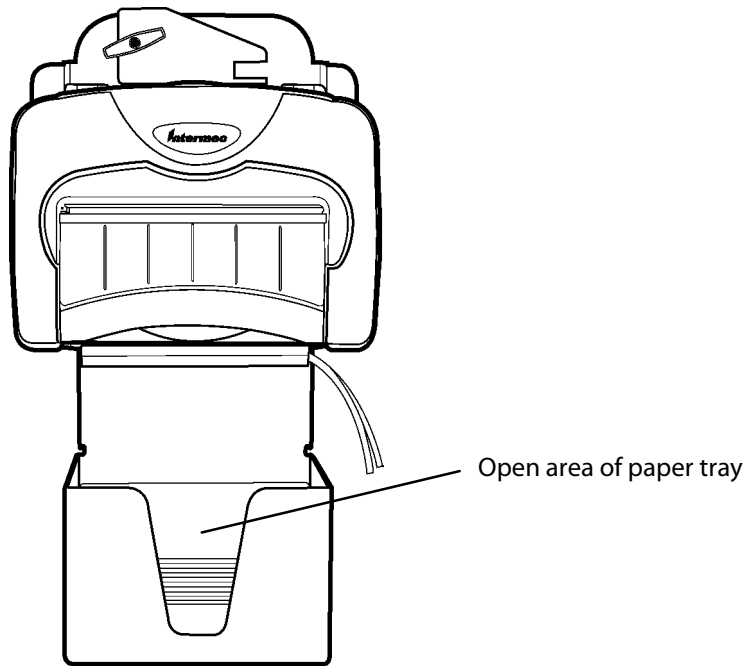

- Pull the top of the form out and up to the printer. Lift the lid and lay the paper onto the pinfeed holders. If you are looking at the front of the form at this point, then the paper is positioned wrong in the paper tray.

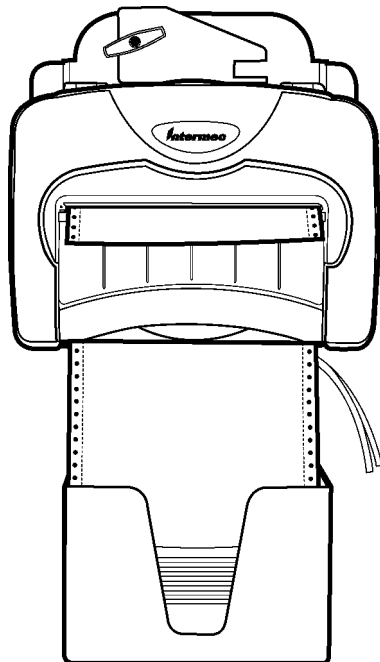

Fill the Dashboard Mount Paper Tray

If you are using a dashboard mount, do the following to load paper:

- 1 On the front door of the box area of the dashboard mount, pull the two latches with springs (circled in the following illustration) inwards (part A), then pull to open the door (part B).

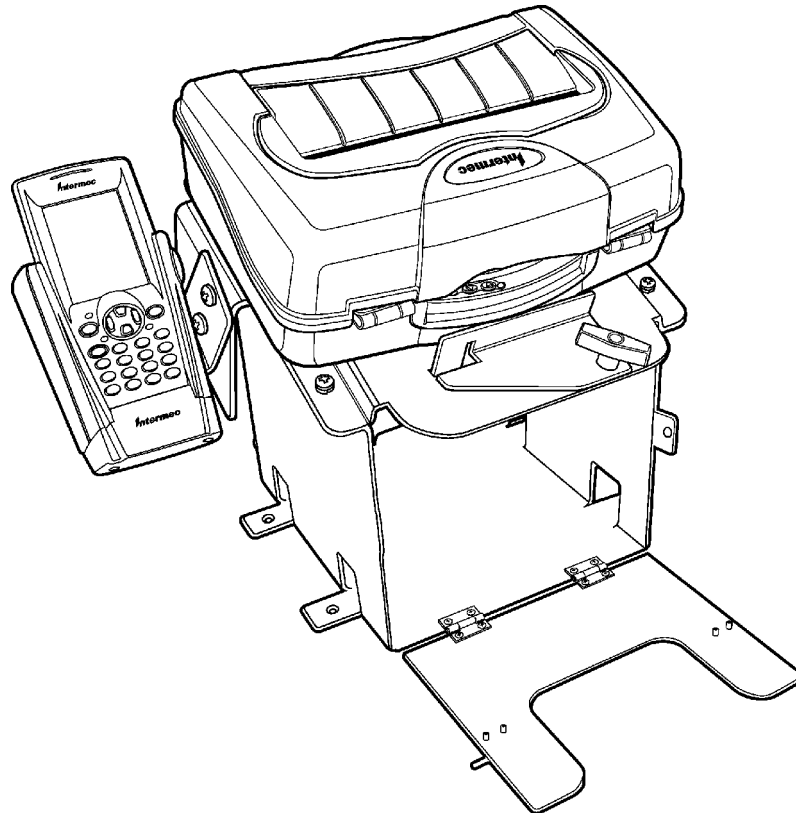
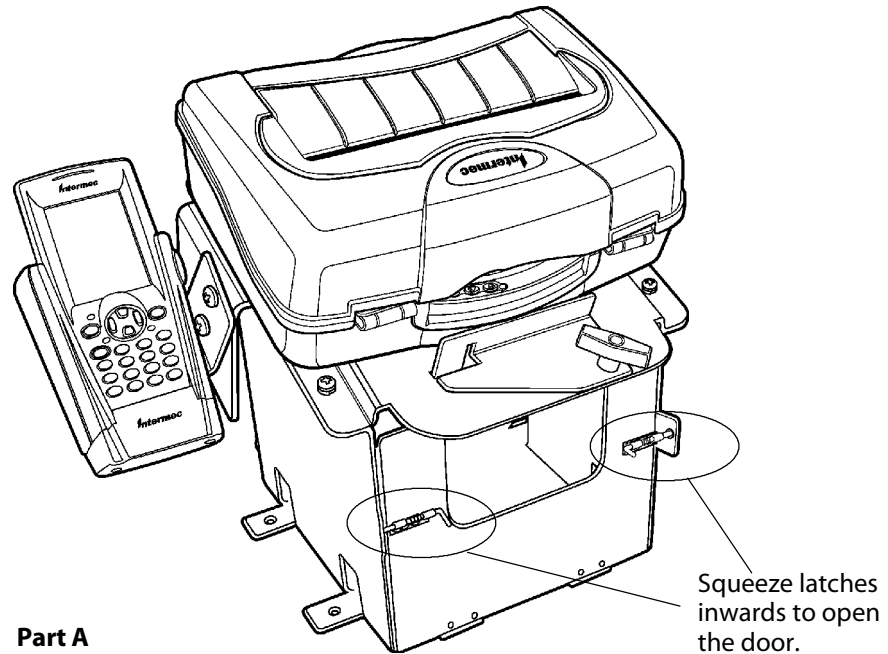

- 2 With the original facing you, insert a stack of paper inside the box.

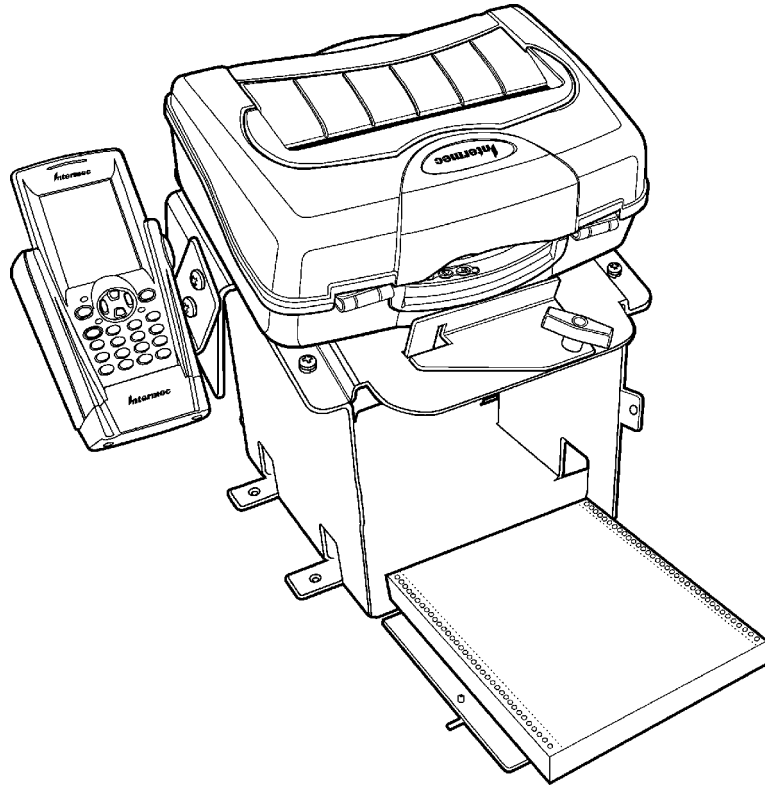

- 3 Squeeze the latches inwards, close the door, release the latches to secure the door. Pull the top form out through the back, then over the printer into the mechanism. Paper loading instructions start on the next page.

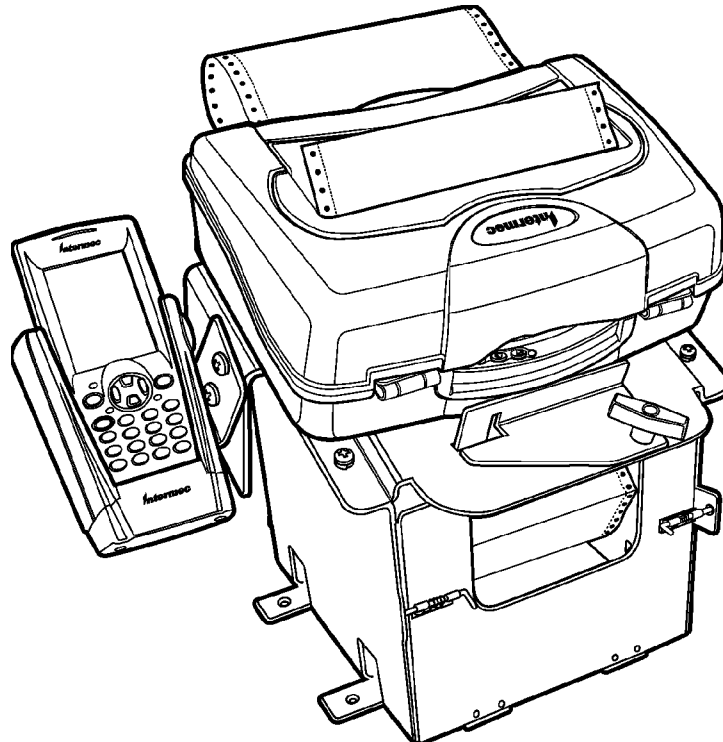

Load Paper into Printer



Follow these steps to load the paper into the printer, or paper jams may occur.

Paper for the PK80 Series Printer has perforated strips that fit onto the pinfeed holder pins, guiding the paper into the printer. This paper is sold separately in 1-, 2-, or 3-ply forms. See “Inside Sales” in Chapter 1 for ordering information and part numbers.

Position the Paper

- 1 Open the pinfeed holders outward.
- 2 Take the top edge of the sheet of paper and position it, *original side facing down*, over the pinfeed holder pins.
- 3 Align the first few holes of the paper, on each side of the paper, onto the pinfeed holder pins.
- 4 Close the pinfeed holders.
- 5 Raise the paper bail.

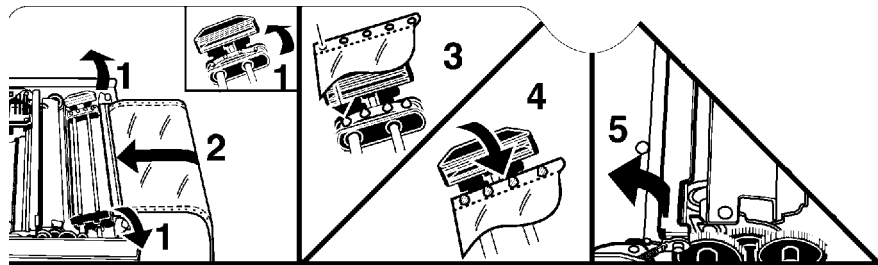

Note: Go to the next page to adjust the pinfeed holders.

Adjust the Pinfeed Holders



Note: There are two pinfeed holders, one next to the green thumb wheel and one opposite the same wheel. Always loosen the pinfeed holder opposite the green thumb wheel.

Adjusting the pinfeed holder next to the green thumb wheel may cause information to print in the wrong place. If this pinfeed holder is moved, correct its location by releasing the pinfeed holder tab, moving the pinfeed holder as close to the green thumb wheel as possible, then locking the pinfeed holder tab, before adjusting the opposite pinfeed holder.

If the paper does not properly fit on the two pinfeed holders Follow these steps to adjust the area between the two pinfeed holders to fit the width of the paper. See the illustration on the next page.

- 1 With the pinfeed holders open, release the locking tab on the pinfeed holder *opposite* the green thumb wheel.
- 2 Adjust the pinfeed holders to align the pins with the paper.
- 3 Close the pinfeed holder.
- 4 Ensure that the paper is smooth (no folds, bulges, bows, etc.) between the pinfeed holders. If so, push the locking tab down on the pinfeed holder that you adjusted.

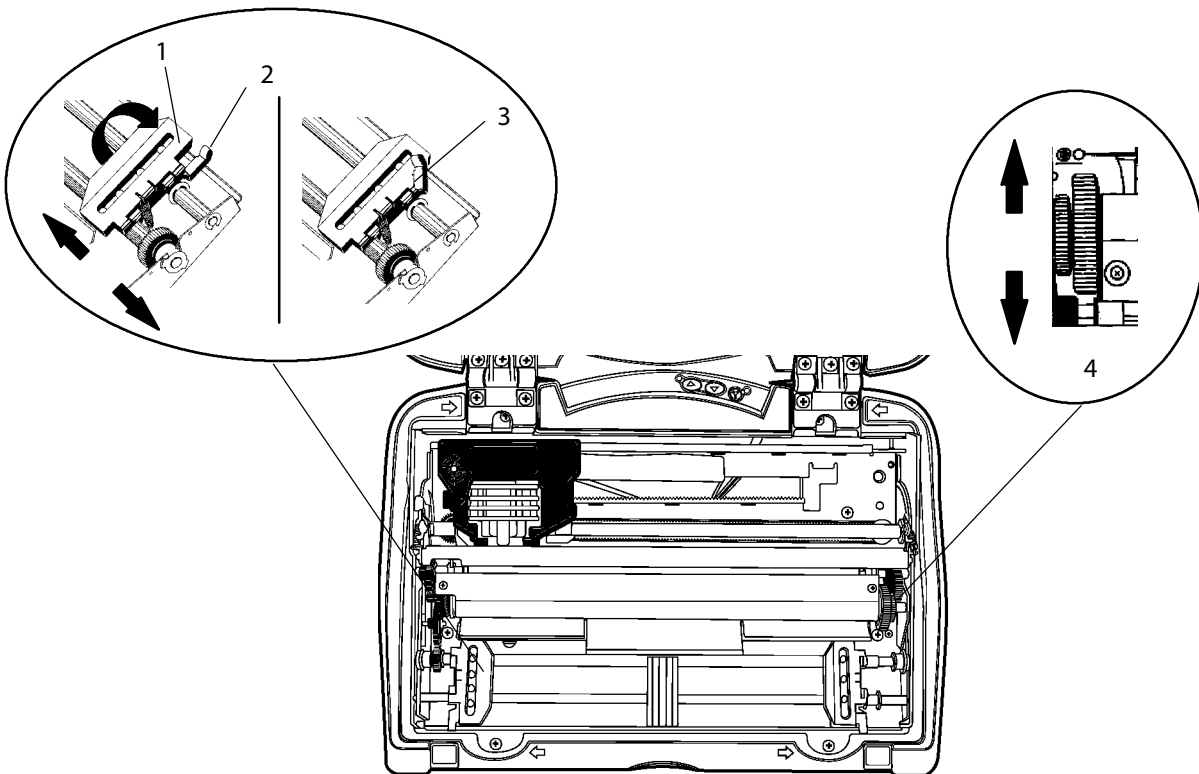

- 1 Pinfeed holder
- 2 Locked pinfeed holder locking tab
- 3 Released pinfeed holder locking tab
- 4 Thumb wheel (green)

Set the Paper

Do the following to feed the paper into the printer:

- 1 Press, and hold, the **Forward** button on the user panel to feed the paper into the printer (6).
- 2 Lower the paper bail (7). An empty printer autofeeds new paper approximately 0.1" (0.25 cm) beyond the top of the paper bail.



Note: The ideal distance to feed paper beyond the paper bail may vary due to environmental conditions (such as humidity) and specific aspects of certain paper. Use the green thumb wheel to position the paper to a desired distance per your conditions.



Note: If your paper has a preprinted logo on every page, make sure the print head is below the preprinted logo. If not, you can adjust the position of the paper, either by pressing, then releasing, the **Forward** button to move the paper forward or the **Reverse** button to move the paper back, or by using the green thumb wheel.

- 3 Close the printer lid. Make sure the paper will pass through the paper slot when the printer starts printing.

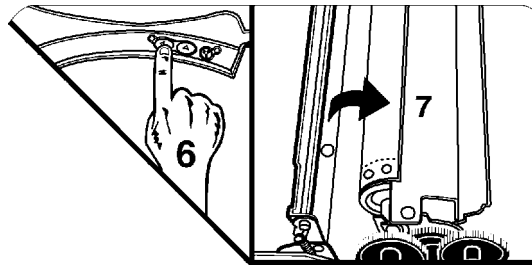

Printer Behavior

This lists behaviors you can expect when working with your printer.

Expectations

Below are some tips to remember when working with Bluetooth:

- The Bluetooth connection is automatically closed when the printer falls asleep.
- The Bluetooth connection is automatically closed when there has been no Bluetooth activity for a period of time. You can configure this period of time via the {BL:xxx} command, where “xxx” ranges from 60 to 65535 seconds (1 minute to more than 18 hours).
- For the Bluetooth Query, add the “I” parameter, which responds with the inactivity timer specified in the previous bullet.

See Appendix A, “*Commands*” for more information about the “I” parameter and the inactivity timer.

Indicators

If the power LED is green, but the printer is not printing, press and hold both the **Forward** and **Reverse** buttons. If the power LED lights up, refer to the following table:

Printer Failure Indicators

Sets of Beeps	Meaning
1 set of 13 beeps	Configuration error.
2 sets of 3 beeps	Paper Out.
3 sets of 4 beeps	Home switch failure.
4 sets of 2 beeps	Head Jam.
4 sets of 4 beeps	Flash write error.
12 sets of 12 beeps	Operating system software failure.

Printer Runs Out of Paper

When a paper outage occurs, the printer emits three short beeps, pauses, then emits three more short beeps to indicate the printer is out of paper. Below is what you should expect when you do any of the following:

Do nothing

The printer times out, reports a “Time Out” status, cancels the print job, and cancels automatic reporting.

Insert paper before the printer times out

The printer reports a “Paper In” status and resumes printing.

Stop the print job — press the Forward button

The printer reports a “Kill Job” status, flushes the print buffer, cancels automatic reporting, and readies for another print job.

Turn off the printer — press both the Forward and Reverse buttons

The printer reports a “Printer Off” status, flushes the print buffer, cancels automatic reporting, and shuts down.

See Chapter 1, “*Introduction*,” for information about the **Forward** and **Reverse** buttons on the control panel.

The printer reports all activity to the print job status report described on the next page.

Printer Head Jams

When the printer head jams, the printer emits two short beeps, pauses, emits two more beeps, pauses again, and continues until it emits eight beeps in all. What to expect when you do one of the following:

Do nothing

The printer times out, reports a “Time Out” status, cancels the print job, and cancels automatic reporting.

Stop the print job — press the Forward button

The printer reports a “Kill Job” status, flushes the print buffer, cancels automatic reporting, and readies for another print job after the print head jam is cleared.

Turn off the printer — press both the Forward and Reverse buttons

The printer reports a “Printer Off” status, flushes the print buffer, cancels automatic reporting, and shuts down.

See Chapter 1, “*Introduction*,” for information about the **Forward** and **Reverse** buttons on the control panel.

Go to page 14 for information about the print head.

The printer sends all activity to the print job status report described on the next page.

Print Job Status Report

This simple protocol assures that data delivered to the printer is printed without mechanical error. Each print job to be monitored begins with an “ESC s n” command, where the “ESC” marks the start of the print job, and bit fields within “n” specify the level of error reporting. The end of the print job is marked by an “ESC e” command.



Note: Spaces are not part of the actual sequences. They are only included here for readability.

Once the print job status is enabled, any detection of a requested condition (see the definition of “n” below) is reported immediately, without the need to query the printer. The printer will send the same string that results from receipt of a status command (ESC{ST?}). In addition, if requested, the printer will automatically send the status when the last print line or FormFeed within the start/end markers is complete.

- ESC s n Start of print job (0x1B 0x73 n)

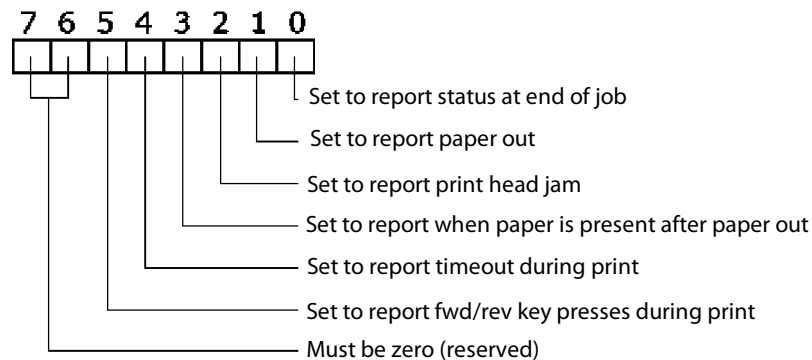

Note: An *n* of all zeroes (0x00) will cancel any active auto status messages set by a previous ESC s n without an ESC e.

- ESC e End of print job (0x1B 0x65)

Response is identical to the status command with Paper Jam and Print Status fields added. Status can still be requested by sending the usual sequence (ESC{ST?}). See Appendix A, “Commands,” for information.

Timing Out

When a time out occurs (ESC{BLI}), a status request is sent indicating the printer has timed out. The current print buffer is flushed, and subsequent automatic reporting is cancelled.

The printer will not time out if the sixth bit is set (cancel timeout) when the ESC s n command is sent to mark the beginning of the print job. If the job has completed printing and the printer is idle, then pressing the **Forward** button on the control panel will not send the “print job kill” message, since there is nothing in the print buffer.

However, pressing both the **Forward** and **Reverse** buttons to turn the printer off will generate the printer off message.



3 Maintenance

The printer lasts longer and performs better when it is operated correctly and kept clean.

Operation Guidelines

Do

Ensure that the computer remains connected to the printer throughout printing or operation.

Make sure the printer cover is closed (*except during maintenance or when loading paper*).

Ensure there is paper properly installed in the paper tray or dashboard mount.

Disconnect the printer power cable when jump-starting the vehicle.

Clean the external surface of the printer using a soft cloth moistened with mild soap and water, a good quality cleaner, such as MICRO-CLEAN II, and if necessary, rubbing alcohol.

Make sure your printer is loaded with paper before communicating with your mobile computer.

Do Not

Spill liquids or food crumbs into the printer.

Sit or stand on the printer.

Use solvents or abrasive cleaners on the printer.

Rest objects on, under, or against the printer.

Allow the printer to be knocked over or physically damaged.

Start or stop the vehicle engine while printing.

Overload paper tray (*paper jams will occur*).

Use objects to remove paper from between the print head and platen (*damage to mask spring/ print head will occur*).

General Cleaning



Caution

Do not use glass cleaners with ammonia. Permanent damage to the printer cover will occur if such glass cleaners are used.



Caution

Do not use abrasives or solvents (or any product containing these substances) to clean any part of the unit. Permanent damage to the printer will occur if such substances are used.



Caution

Never use ketonic solvents (acetone or ketone) or aromatic solvents (toluene or xylene) to clean any part of the printer. Doing this can damage the printer.



Note: MICRO-CLEAN II is the only cleaner recommended for this purpose. Other cleaners can damage the case.



Note: GUIDE SHAFT CLEANER is recommended for cleaning your 80-column printer guide shafts. Cleaning the printer guide shaft can reduce the number of head jams caused by dirt and buildup.

Both cleaners are sold separately. See “*Inside Sales*” in Chapter 1 for ordering information and part numbers.

Periodic cleaning helps maintain the appearance and reliability of the printer. When cleaning the printer, inspect both the outside and the inside for obvious signs of damage, wear, or impending failure.

Outside Cleaning

Do not pour liquid cleaners directly on the printer case. Instead, dampen a soft, lint-free cloth with a quality cleaner and clean the exterior surfaces with this cloth. *Do not use solvent solutions.* Inspect all cables and the remote terminal holder or vehicle dock for damage.

Inside Cleaning



Let the printer cool before you clean the inside of the printer, or you may burn your fingers.

Open the printer cover and inspect the ribbon cartridge and all visible moving parts on the printer mechanism for signs of wear or damage.

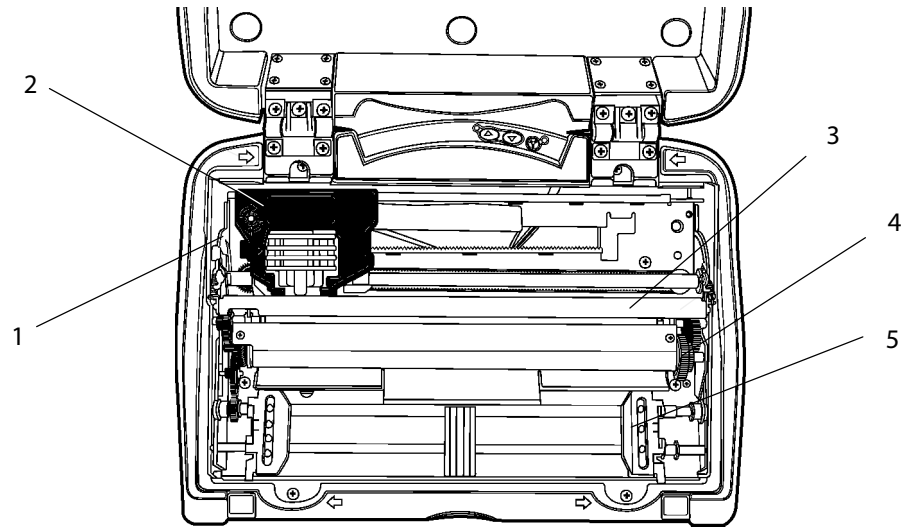

- 1 Head gap adjuster
- 2 Ribbon cartridge
- 3 Paper bail
- 4 Thumb wheel (*green*)
- 5 Pinfeed holder

This illustration shows the visible moving parts of the printer mechanism.

Use a low-pressure, dry air source, such as “canned air” available at electronic supply houses and typewriter repair facilities, or a vacuum, to remove accumulated paper dust from the printer mechanism.

The printer ribbon contains a special lubricant to ensure that the fine dot wires inside the print head receive adequate lubrication. Replace the ribbon frequently to prolong the life of the print head. The printer requires no additional user-applied lubrication. Ribbon cartridges, available in black or purple, are sold separately. See “*Inside Sales*” in Chapter 1 for ordering information and part numbers.

Old Ribbon Cartridge Removal

Physically move the print head mechanism to an open area, then do the following to remove the old ribbon cartridge:

- 1 Squeeze the ribbon cartridge locking tab (on the side of the cartridge) against the ribbon cartridge.
- 2 Lift the ribbon cartridge to remove the ribbon from the print head. Ensure the ribbon does not catch.
- 3 Lift the ribbon cartridge out of the printer.

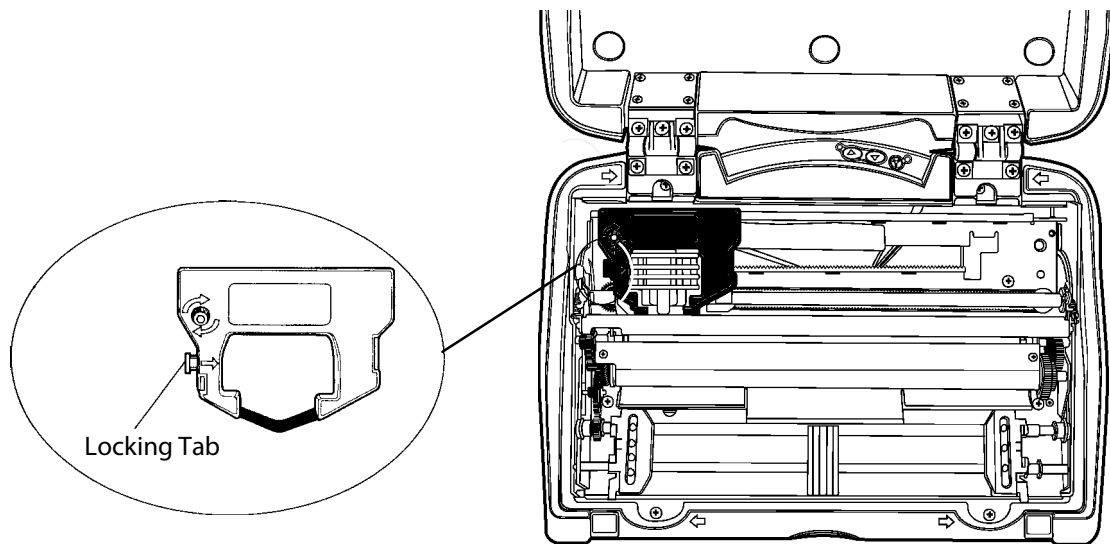

Mask Spring Cleaning

Look at the mask spring behind the print head. If the mask spring needs to be cleaned, go on to the next page. If the mask spring appears to be in good condition, install a new ribbon cartridge as described on page 13.

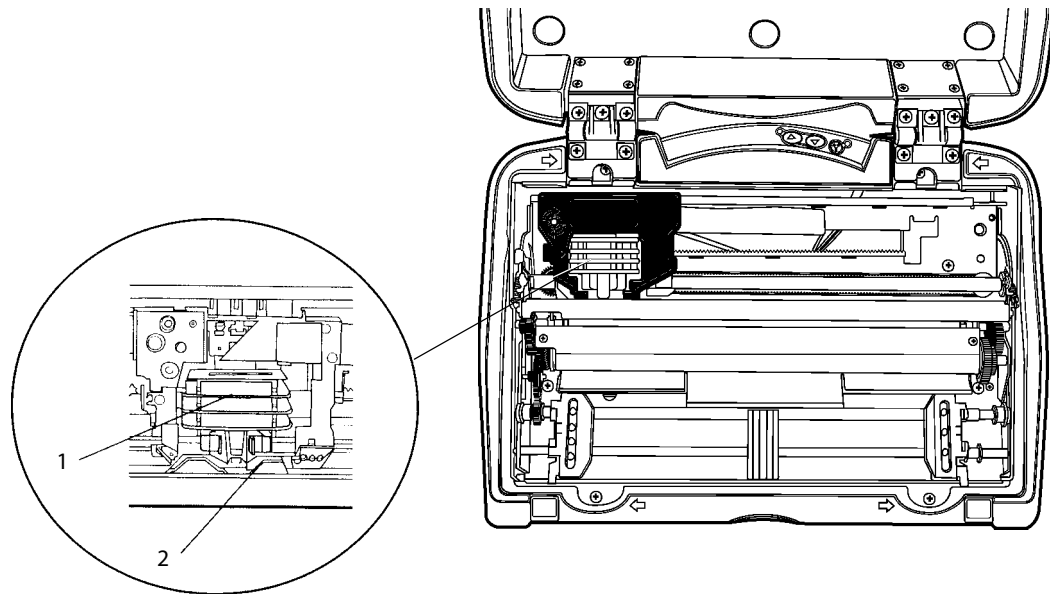

1 Print head
2 Mask spring

Do the following to clean the mask spring:

- 1 Unlatch the print head locking tabs to release the print head, lift the print head and set aside, then lift up the paper bail. *Do not detach the print head unit.*



Never use a sharp object, such as pinchers, to clean between the print head and the platen (rubber roller). This can damage the mask spring and print head.

- 2 Remove the clear plastic paper guide that seats the mask spring, if necessary. Use your fingernails to loosen the base of the paper guide, then pull the paper guide straight up from the printer mechanism.
- 3 Remove the metal mask spring from the paper guide and clean with a quality cleaner. Replace if damaged.
- 4 Put the good, clean mask spring into the paper guide and install the paper guide into the printer.

- 5 Close the paper bail, reinsert the print head, latch the two print head locking tabs, and install the ribbon.

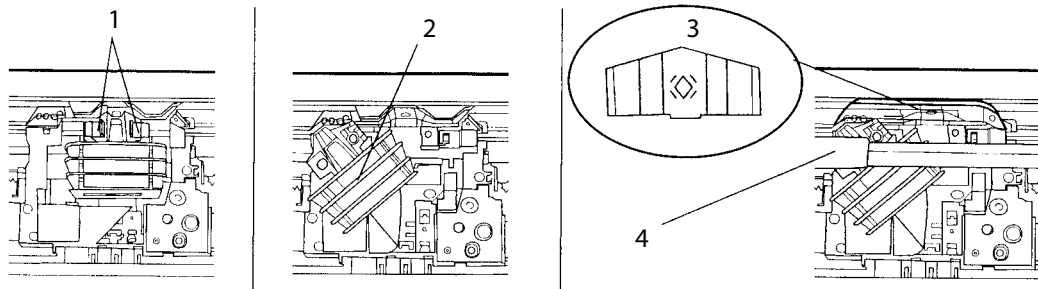

- 1 Print head locking tabs
- 2 Print head (*lifted aside*)
- 3 Mask spring
- 4 Paper bail (*raised*)



4 Troubleshooting

This chapter helps you correct printing problems that may occur. If you experience a printing problem, you can perform several tests to find and possibly cure the problem.

Check the Power Source

The printer will automatically power down after a configurable period of inactivity. Activity is either sending data or pressing a button. The timer resets during printing. You can awake the printer either by sending data or pressing either the **Forward** or the **Reverse** button on the user panel.

If there is power, the power LED turns on and the print head moves to its “home” or starting position. If the printer emits beeps and power LED lights up or flashes, observe the number of beeps and flashes and refer to the table on page 38 for an error message.

If there is no reaction from the printer after pressing a button on the user panel, or only the power LED blinks, verify that the power cables are properly connected between the printer and its power source (internal battery, vehicle cable, or ac). If neither of these steps “wake” up the problem printer, then return the printer for service.

Vehicle cable:	Attach the printer to another vehicle power cable.
AC power:	Plug the printer into another outlet.

Large Print Jobs

Printing large files with 15 pages or more can cause lost data issues because of limited printer buffer size and time out length on the mobile computer. To prevent problems, you can adjust the time out lengths on the mobile computer. If you encounter a problem concerning large print jobs, contact Customer Support at 800-755-5505 for further help

Printer Cold-Boot

Should you need to reset the Fixed Mount Printer, simply remove power from the printer, wait a few moments, then return power to the printer.

Self-Test



Note: Each time the printer is powered up, it reads flash values into RAM. As long as the printer is on and awake, it updates those values in RAM. When the printer is powered off, or falls asleep, the values are written into flash. If power is disconnected instead of the printer being powered off or falling asleep, then updates in RAM are lost.

Press and hold the **Forward** button through a form feed (more than five lines). If it is still held down at the end of the form feed, it prints the self-test. Internal tests are performed and a 1-page report is printed. This report provides helpful tips in diagnosing/troubleshooting printer problems.



Note: You can abort the self-test by pressing a button while it is printing.

When the self-test is performed, the following actions occur:

- Voltage and ambient temperature are obtained
- Validity of diagnostic block program is checked
- Validity of BootBlock program is checked
- Validity of control program is checked
- Validity of loaded fonts is checked
- Self-test report is printed

The self-test report is divided into sections. See page 36 for a sample.

The printer model number is given on line 1 (first line). This identifies the printer type being used, such as PK80F.	
The serial number of the printer is listed on line 3 under the “Serial#” heading on line 2. The serial number is also on the inside of the printer.	
The “Auto Feed” setting, on line 13, is a configurable item. “CR” Carriage Return means no auto linefeed. This is the most common setting for applications. “CR+LF” means a linefeed will be added to each CR. This setting can produce double-spacing of reports.	
The “Interface Mode” setting, line 14, lists the interface protocol for the printer. A typical setting can be DTR with no, odd, or even parity.	
“Baud Rate” on line 16, lists the baud rate for the printer. Most application software autobauds so you do not have to select it. Bit rate is commonly set to 19200 (19.2K) or 9600 bps.	
“A2D History,” lines 63 through 66, is the history for voltage measurements and temperature measurements, as recorded by the printer.	
“Head Jam History” on lines 68 through 71, gives information on head jams. If the printer is having frequent head jams, these lines can assist in determining the problem.	
“Direction” tells which way the head was moving, “left” toward home and “right” away from home. Home position is at the extreme left, toward the green thumb wheel.	
“Step” is the acceleration step at the jam. “0” means no steps were taken, “15” means all steps were taken. “1–14” means printer jammed during acceleration or deceleration.	
“Speed” is the acceleration speed of the print head when the jam occurred.	
“Temp” is the ambient temperature at the last head jam. The temperature is listed in Celsius.	
“Position” of carriage at the jam in 1/720 inches = 12 * step position. Divide the number by 12 to get the step position. There are 512 steps across the page. If it is jamming in the middle, it is more likely a dirty ribbon or obstruction in the print head’s path.	
“Head Dot Pattern,” appearing after “Total Head Jams,” is printed to verify the individual dot wires. There should be nine dots. If some are missing, it could be a print head failure or a circuit board failure.	
“Error Log” information appears in the second-to-last group of lines, This information is cleared after every self-test. This information is very helpful in determining problems.	
“HJ”	# of head jams while print head is moving
“12Vu”	# 12-volt under voltage
“12Vo”	# 12-volt over voltage
“Home”	# Home detect errors (<i>typically caused by paper scraps or circuit failures</i>)
“EEErr”	# EEPROM write failures to diagnostic block

All other values are informational only. Remember that these values are cleared after the self-test.

Sample Self-Test



Note: Lines 10–19 are factory-default printer settings. Take note of these lines when reading the self-test report.

```

1  Intermec PK80F
2  Copyright 2003 All Rights Reserved
3  Serial#   MFG Date -----Hardware-----
4  1234567   01/24/05   PK80F 8in Impact Printer
5  Printer Firmware: - Version 5.54
6  BootBlock:      - Version 5.06
7  Comm Controller: - Version 5.30
8  Flash/RAM Memory: - 8/4 Mbit
9
10 Printer Configuration:
11   Printer Timeout:           60S
12   RF Power Down Timeout:     Never
13   Auto Feed:                 CR=CR LF=CRLF
14   Interface Mode:           LP
15   Beeper:                    On
16   Baud Rate (Serial RS-232): 19.2K
17   Data Bits (Serial RS-232): 8
18   Parity (Serial RS-232):    None
19   Handshaking (Serial RS-232): Hardware
20
21 Wireless RF Printer Configuration:
22   Wireless Device Address:    00:80:37:19:3A:23
23   Wireless Device Name:      "PK80-1234567"
24   Wireless Service Name:     "Wireless Printer"
25   Wireless Profile:          Serial Port (SPP)
26   Class of Device/Service:    040680 Rendering Imaging Printer
27   Discoverable:              Yes
28   Connectable:              Yes
29   Bondable:                  Yes
30   Encryption:                No
31   Authentication:           No
32   Passkey:                   Key present
33   Inactivity Disconnect Timeout: 60S
34
35 Fonts: LOC  CPI   *---DESCRIPTION---*  V  *-DATE-*  *---NAMES---*
36   R   10.5  255CH PICA CP437 REG  3  02/06/03  PR437  A(41H)
37   R   12.7  255CH ELIT CP437 REG  3  02/06/03  ER437  B(42H)
38   R   10.5  255CH PICA CP437 ITA  3  02/06/03  PI437  C(43H)
39   R   12.7  255CH ELIT CP437 ITA  3  02/06/03  EI437  D(44H)
40   D   Vary  224 CH TRADTN ARABIC  4  06/20/01  ARABT  d(64H)
41   D   Vary  224 CH SMPLFD ARABIC  4  07/11/01  ARABS  e(65H)
42   D   Vary  224 CH E-MAPD ARABIC  4  07/11/01  ARABE  f(66H)
43   D   10.5  224 CH GREEK-DOS MAP  3  02/01/01  GRDOS  g(67H)
44   D   10.5  224 CH GREEK-WIN MAP  4  02/01/01  GRWIN  h(68H)
45   D   10.5  255CH PICA ISO01 REG  2  10/30/01  ISO10  i(69H)
46   D   12.7  255CH ELIT ISO01 REG  2  10/30/01  ISO12  j(6AH)
47   D   10.5  ISO 8859-09 PICA  2  04/18/03  PRI09  l(6CH)
48   D   12.7  ISO 8859-09 ELITE  2  04/18/03  ERI09  k(6BH)
49   D   10.5  Hebrew ISO8859-8 Map  2  09/29/03  HBISO  m(6DH)
50   D   10.5  Hebrew DOS CP862 Map  2  09/29/03  HBDOS  n(6EH)
51   D   10.5  254 CH CYRILC CP-866  3  03/27/01  CY110  +(2BH)
52   D   10.5  255 CH CYRILC 8859-5  3  03/27/01  CY210  -(2DH)
53   D   10.5  Code Page 852 PICA  2  05/13/02  DL210  ^(5EH)
54   D   12.7  Code Page 852 ELITE  2  10/28/02  DL212  _(5FH)

```



```

55          D    9.0   DOS10 W/ EURO @ 0x7F   4   05/17/02 DOS10   p(70H)
56
57 Current Statistics:
58   Battery Voltage:    13.2V
59   Total Pages:       205
60   Cold Starts:       56
61   Warm Starts:       1345
62
63 A2D History
64   Curr      Low      High      Min      Max      Error      Page      Count
65 12V:  13.20   00.00   00.00   07.00  16.80   00.00   00000   00000
66      000      000      000      000    000      000
67
68 Head Jam History
69 Total Head Jams:    1
70 Motion Direction   Ramp   Step   Speed Temp      Position Page
71 Print Right        Const  000   High  +00.0C   00708   00183
72
73 Head Dot Pattern
74

```

```

-----

```

```

75
76 Error Log
77 HJ    12Vu  12Vo   Home   EEErr
78 00000 00000 00000 00000 00000
79
60 !#$%&()*+;=>?ABCDEFGHIJKLMNOPQRSTUVWXYZabcdefghijklmnopqrstuvwxyz01234567890
61 !#$%&()*+;=>?ABCDEFGHIJKLMNOPQRSTUVWXYZabcdefghijklmnopqrstuvwxyz01234567890!
62 !#$%&()*+;=>?ABCDEFGHIJKLMNOPQRSTUVWXYZabcdefghijklmnopqrstuvwxyz01234567890!#
63 !#$%&()*+;=>?ABCDEFGHIJKLMNOPQRSTUVWXYZabcdefghijklmnopqrstuvwxyz01234567890!#$

```

Report Failure

If a partial report generates and a printer error occurs during printing, refer to the table on the next page for troubleshooting help.

If the printer does not generate a report:

- There may be a printer failure, refer to the troubleshooting table on the next page for possible solutions.
- There may be a power failure, check the power source (internal battery, charge cable, or ac adaptor).

Possible Printer Problems

The following table lists actual printing problems, possible causes, and actions you should take to correct a problem. Call 800-755-5505 or 425-356-1799 if you are advised to contact Customer Support.

Symptom	Test or Cause	Solution
Printer does not communicate with the mobile computer.	Incorrect protocol selection.	Contact Customer Support.
Double-spacing on application reports but single-spacing on self-test.	Check line 11 on the self-test report, if “CF+LF” then this is an incorrect configuration.	Contact Customer Support.
Printer emits 1 or 2 beeps or blinking green light is the only indicator.	Printer mechanism does not have adequate power for printing. The 12 V may be under or over voltage fault. <i>(Note: Error lights do not flash if high voltage.)</i>	Check power supply if one is used. If power supply, adjust supply voltage to 11–15 volts. Check the vehicle charge cable (see the <i>PK8X Series 80-Column Printer Installation Instructions</i> for information).
Printer emits 2 sets of 3 beeps	Printer out of paper.	Press the Forward button to stop the beeps. Reload paper — see page 15 for instructions. If the “paper out” condition still exists, the printer will beep again.
Printer works but either or both LEDs do not work.	Discrete cable connecting user panel board to pivot frame assembly is loose.	Call Customer Support or send the printer in for hardware repair.
Printer does not work.	(1) No voltage. (2) Voltage too high or too low. (3) No data input.	(1) Adjust supply voltage to 11–15 volts. (2) Adjust supply voltage to 11–15 volts. (3) Tighten computer connections.
Printer is emitting 4 sets of 2 beeps and has stopped printing.	The printer had detected a paper jam during homing.	Power off the printer, clear the jam as advised below, then power on or awaken the printer.
No paper feed (paper jam). When I pull the paper toward the roller the paper is resistant.	(1) Paper tray or dashboard mount may be too full. (2) The paper perforation may be torn. (3) The paper may be wrinkled, creased, moist, or perforations may be missing.	(1) Ensure there are fewer than 200 3-ply sheets in the paper tray or dashboard mount. (2) Remove the torn paper, load and center a clean stack of paper, and adjust the pinfeed holders. See page 20 for instructions. (3) Replace the paper.

Symptom	Test or Cause	Solution
No paper feed (head jam). When I move the print head manually from side to side, the print head is resistant.	(1) Ribbon may be jammed.	(1) Remove ribbon cartridge and turn knob. If ribbon resists, replace ribbon cartridge. See page 13 for instructions.
	(2) Mask spring may be bent or damaged.	(2) Replace the mask spring. See page 30 for instructions.
	(3) Print head gap adjuster may be too low.	(3) Set the head gap adjuster to the fifth notch <i>away from the paper</i> . See page 14 for instructions.
	(4) Paper scraps are found in the printer mechanism or around platen.	(4) If the ribbon cartridge bumps against the inside of the printer, check the white ribbon cable, home position sensor, and four screws. Remove any paper scraps and do a cleaning.

Communications with Host Computer

The self-test report can verify that the communications protocol options selected for the printer match those expected by the host computer. If these options do not match, then reconfigure the printer using Easy Print commands or the PK80 Configuration program. See Appendix A, “*Commands*,” for more information about the Easy Print commands.

If the protocol options do match, then the data communications cable may be defective. Verify that the cable is working by substituting a new cable or host computer. Also check the computer vehicle dock.

Communications Pin-Out Configurations

Below are common cable configurations between a mobile computer or a dock and the printer:

Mobile Computer	Pin #	Fixed Mount Printer or Remote Mount Terminal Holder	Pin #	Signal Name
Chassis Ground	shell ^{shield} 1	NC (No Connection)		
Charge Input	8	HHC_CHARGE	9	
SG (Signal Ground)	9	GND	7	
DSR (Data Set Ready)	7	NC	6	
DTR (Data Terminal Ready)	2	NC	20	
CTS (Clear To Send)	6	RTS	5	
RTS (Ready To Send)	3	CTS	4	
RXD (Receive Data)	5	TXD	3	
TXD (Transmit Data)	4	RXD	2	

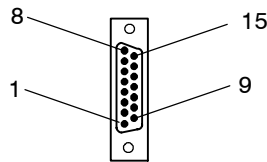

15-Pin DSUB Male

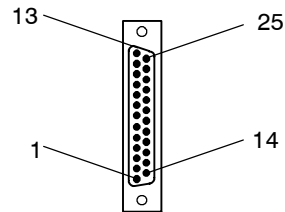

25-Pin DSUB Male

15-Pin to 25-Pin Cable
P/N: 216-605-XXX

PC	Pin #	Fixed Mount Printer	Pin #	Signal Name
DTR (Data Terminal Ready)*	20	NC (No Connection)	20	
RC (Receive Carrier)*	17	NC	17	
TC (Transmit Carrier)*	15	NC	15	
DCD (Data Carrier Detect)*	8	NC	8	
SG (Signal Ground)	7	GND	7	
DSR (Data Set Ready)*	6	NC	6	
CTS (Clear To Send)	5	RTS	5	
RTS (Ready To Send)	4	CTS	4	
RXD (Receive Data)	3	TXD	3	
TXD (Transmit Data)	2	RXD	2	
Chassis Ground	1	NC	1	

* Signals are not available on the 6100 Dock

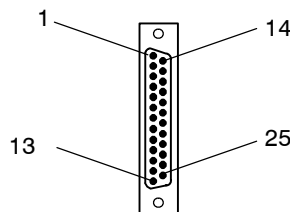

25-Pin DSUB Female

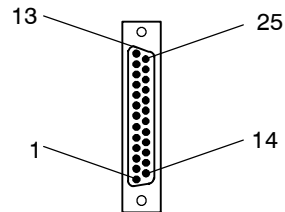

25-Pin DSUB Male

25-Pin to 25-Pin Cable
P/N: 216-771-XXX

Vehicle Dock

Signal Name
CD (Carrier Detect)
RXD (Receive Data)
TXD (Transmit Data)
DTR (Data Terminal Ready)
Chassis Ground
DSR (Data Send Ready)
RTS (Ready To Send)
CTS (Clear To Send)
RI (Ring Indicator)

Pin #	Pin #
1	
2	3
3	2
4	20
5	7
6	6
7	4
8	5
9	
shell	shield
	shell

Printer

Signal Name
No Charge
TXD
RXD
DSR
Chassis Ground
DTR
CTS
RTS
No Charge

9-Pin to 25-Pin Cable
P/N: 321-355-XXX

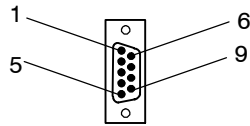

9-Pin DSUB Female

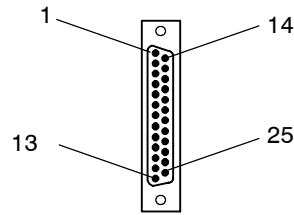

25-Pin DSUB Male

Vehicle Dock

Signal Name
CD (Carrier Detect)
RXD (Receive Data)
TXD (Transmit Data)
DTR (Data Terminal Ready)
Chassis Ground
DSR (Data Send Ready)
RTS (Ready To Send)
CTS (Clear To Send)
RI (Ring Indicator)

Pin #	Pin #
1	
2	3
3	2
4	20
5	7
6	6
7	4
8	5
9	
shell	shield
	shell

Printer

Signal Name
No Charge
TXD
RXD
DSR
Chassis Ground
DTR
CTS
RTS
No Charge

9-Pin to 25-Pin Cable
P/N: 321-582-XXX

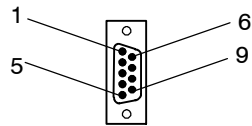

9-Pin DSUB Female

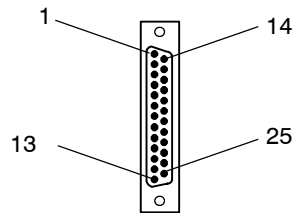

25-Pin DSUB Male

The printer has a 25-pin connector with the following pinout designations and signal mnemonics:

Printer Communications Connector Pin-Outs

DB25	Signal Name	Type	I/O	Description
20	NC	— — —	— — —	No Connection
4	CTS (Clear To Send)	RS-232	IN	Wake up
2	RXD (Receive Data)	RS-232	IN	Printer's RxD
3	TXD (Transmit Data)	RS-232	OUT	Printer's TxD
5	RTS (Ready To Send)	RS-232	OUT	Printer's RTS
9	HHC_Charge	Power	OUT	11–15 V, up to 1 A per contact
7	GND	Power	OUT	SG (Signal Ground)

A Commands

This appendix lists Easy Print and Bluetooth configuration and query commands and control sequences that are supported by the PK80 Series 80-Column Printer.



Note: Printer configuration applications may not determine printer communication speed if the printer is out of paper. Make sure the printer has paper when doing reconfiguration and firmware upgrading.

Commands

Below are the commands and the pages where their information begins:

- Bluetooth Wireless Configuration (*next paragraph*)
- Easy Print (*page 45*)
- Query (*page 46*)

Some of these commands are identified as Easy Print commands, which must be preceded by ESC EZ. Printers must also receive the “{” as part of the ESC EZ sequence to be placed into Easy Print mode.

Bluetooth Wireless Configuration Commands

All commands are enclosed in ‘{’ and ‘}’. They begin with three letters; if there is data that follows the letters are terminated with a colon “:”. Each parameter can be configured is identified by a unique letter, followed by a colon, followed by the data for that parameter. If the configuration type permits, multiple parameters can be changed in one command by separating them with a semicolon “;”. All commands *must* be sent in uppercase.. Spaces in the data are not allowed unless they are part of the data.

After receiving the command, the data is written to flash and the printer restarts using the new values. This all takes less than one second.

- 1 Configure default values. ALL configuration parameters can reset to their original default (non-printer specific) values by sending “{CDV}” - Configure Default Values
- 2 Configure Bluetooth. As of this date, only the Bluetooth Friendly Name can be reconfigured by sending a command of the form “{CBT:<parms>}”
 - F: <data> for Friendly Name (Device Name)
Send up to 16 characters.
 - D: <data> for Discoverable (<data> = Y/N)
 - C: <data> for Connectable (<data> = Y/N)
 - B: <data> for Bondable (<data> = Y/N)
 - E: <data> for Encryption (<data> = Y/N)
 - A: <data> for Authentication (<data> = Y/N)
 - P: <data> for Passkey
Send up to 16 characters (*default passkey is “passkey”*)
 - I: for Inactivity Timeout (*see pages 22 and 55 for more information*)

Example

ESC EZ{CBT:F:MyPrinter} would configure the Bluetooth Friendly Name (AKA Bluetooth Device Name) to MyPrinter.

ESC EZ{CBT:F:BTPrinter;D:N;C:Y;E:Y;A:Y;P:Passkey1} would configure the Bluetooth Device Name to BTPrinter, the printer would not be discoverable but would be connectable, encryption can be used, authentication is required, and the passkey is "Passkey1".

Easy Print Commands

{CT:nnn}	Configures the timeout where <i>nnn</i> can be 15–9998 seconds. 9999 seconds will cause the printer to NEVER timeout.
{CB:n}	Configures the baud rate where <i>n</i> corresponds to the desired baud rate: 0=1200, 1=2400, 2=4800, 3=9600, 4=19.2K (19200), 5=38.4K (38400), 6=57.6K (57600), and 7=115.2K (115200).
{CN:n}	Configures the number of data bits where <i>n</i> can be 7 or 8
{CP:n}	Configures parity, where <i>n</i> can be N (no parity), E (even parity), or O (odd parity).
{CC:n}	Configures the carriage return to automatically add LF to CR, where <i>n</i> can be N for CR=CR, or Y for CR=CRLF.
{COMMIT}	None of the two letter configuration commands will take affect until the COMMIT command is sent. When {COMMIT} is sent, the values are written to flash and the printer is restarted. When it restarts, it will use the default configuration, which in most printers is NOT Easy Print. To do additional configuration, you will need to put the printer back into Easy Print mode.
{CH:n}	Configures handshaking. Valid values are None (N), Hardware(H), Software(S), or Both(B)
{CR:nn}	Configures the radio timeout. Values of 0 or 65535 disable the radio timeout. Other valid values are 1–65534.

The following are configurable and the state will be indicated on the self test printout, but they have no operational effect yet.

{CS:n}	Configures the beeper either ON or OFF where <i>n</i> =Y for beeper ON or N for beeper off.
{LP}	This returns the printer to a line printer mode.
{S}	This returns a status command. The response is of the {U:1234;P;D;O;RDY} form where the <i>P</i> position indicates paper is present and an <i>N</i> in the same position indicates no paper. All other characters are fixed.
{IPL: 0xAA 0x55}	This jumps the printer to the boot code for erasure and subsequent downloads.

Query Commands



Note: Any time ESC is used in a command, the command needs to contain the actual ASCII character for ESC (0x1B), not the letters E-S-C. There should be no spaces before the next character. Sometimes a space is included in the documentation for readability.

Queries can be sent to the PK80 Printer via the Bluetooth or the RS-232 data link. The printer's reply to a query returns information about the printer or the print request. There are three steps involved:

- 1 Frame your query using the correct command format.
- 2 Send the Query (for example, via an applications program or a terminal emulator such as "Terminal" in the Windows Accessories group).
- 3 Use the appropriate table to interpret the printer's reply.

Interpreting the Reply to a Query

Consult the table for each Query command to interpret the reply. Each reply contains several pairs of letters. The first letter or "query character" is separated from the reply character by a colon (:) and the pair is followed by a semicolon (;). Example: E:N; (part of the reply to a STATUS query). According to the STATUS table, the E refers to "errors" in Easy Print Commands. An N means "no errors."

Quick Reference

Command	Format	Description
Status	ESC{ST?}	Returns information about the printer's ability to print the next report, and reports any errors from the last print request, such as paper condition, command errors, buffer size, or battery voltage.
Configuration	ESC{CF?}	Returns information about configuration options, such as baud rate, default mode, time-out, etc.
Version	ESC{VR?}	Returns the version number of the loaded firmware, boot code, and download files.
Memory	ESC{MY?}	Returns the size of all memory available — the amount used and the amount remaining for the application.
Print Head	ESC{PH?}	Returns the print head type in use and the number of dots across.
Fonts	ESC{FN?}	Returns a list of available fonts.



Note: The order of the printer's reply to a query may change, and new queries will be added. Therefore, search for the "Query character" to find data whenever interpreting the reply to a query.

ESC{ST?} — Status

This shows whether the next print request is doable, or returns information about errors from the last request.

Query Format

```
ESC{ST?}
```

Reply Format

```
{ST!E:x;S:x;L:x;P:x;J:x;R:x;B:x}
```

Reply Example

```
{ST!E:N;S:K;L:D;P:N;J:N;R:21;B:O,H:O}
```

- **ST!** This is a reply to a STATUS query.
- **E:N;** There are no errors.
- **S:K;** A key was pressed to cancel a print job.
- **L:D;** The paper release lever is down, ready to print.
- **P:N;** Paper is missing.
- **J:N;** There is no paper jam.
- **R:21;** 21 *K* bytes remain in the input buffer.
- **B:O;** Acceptable battery voltage and temperature

Query	Reply	Definition of Reply
E	N	No error*
E	c	Command error (invalid command)
E	d	Data error (such as a letter in a numeric-only bar code).
E	f	Font not available
E	g	Global parameter error
E	o	Overrun of buffer*
E	p	Field parameter error
E	q	Qmark not found*
E	r	Row or Column error
E	s	Syntax error
S	I, P, T, K, O, C, J	Status = Idle (I), Still printing (P), Timeout (T), Key pressed to cancel job or turn unit off during printing (K), Unit turned off while idle, such as after paper out (O), Complete reported after end of job and for up to 200 ms after job is finished (C), Paper jam detected (J)
L	U, D	Lever = Up (U) or Down (D)
P	P, N	Paper = Present (P) or Not present (N)
J	N, J	Paper jam = None (N) or Jam (J)
R	nn	RAM buffer size remaining in <i>K</i> bytes.
B	O, T, V	Battery condition = Okay (O); Out of temperature range (T); Out of voltage range (V)

**Rows marked with asterisk apply to Easy Print and Line Printer Mode. Rows without an asterisk apply only to Easy Print.*

ESC{CF?} — Configuration

This returns information about configurable options.

Query Format

ESC{CF?}

Reply Format

{CF!L:x;B:x;P:x;N:x;H:x;S:x;T:x;R:x}

Reply Example

{CF!L:LP;B:096;P:N;N:8;H:B;S:Y;T:0060;R:0600}

- CF! This is a reply to a Configuration query.
- L:LP; The default mode is Line Printer.
- B:096; The baud rate is 9600.
- P: N; No parity is set.
- N:8; There are 8 data bits.
- H:B; Hardware and software handshaking are enabled.
- S:Y; The sound is on.
- T:0060 The timeout is set for 60 seconds.
- R:0600 The radio timeout is set for 600 seconds.

Query	Reply	Definition of Reply
L	LP, EZ	Default mode: Line Printer (LP) or Easy Print (EZ)
B	012, 024, 048, 096, 192, 384	Baud Rate: 1200 (012), 2400 (024), 4800 (048), 9600 (096), 19.2K (192), or 38.4 baud (384)
P	N, E, O	Parity: None (N), Even (E), or Odd (O)
N	7, 8	Number of Data Bits: 7 or 8
H	N, H, S, B	Handshaking: None (N), Hardware (H), Software (S), or Both (B)
S	Y, N	Beeper (Sound): Yes (Y) or No (N)
T	nnnn	Timeout value in seconds (9999 = always on)
R	nnnn	Radio timeout value in seconds. Values of 0 or 65535 disables the radio timeout. Other valid values are 1–65534.

ESC{VR?} — Version

This reports the firmware, boot code, and download file number.

Query Format

ESC{VR?}

Reply Format

{VR!**F**:x;**B**:x;**D**:x}

Reply Example

{VR!**F**:4.09;**B**:2.05;**D**:1.0}

- **VR!** This is a reply to a VERSION query.
- **F:4:09;** The firmware (main program) version is 4.09.
- **B:2.05;** The boot code version is 2.05.
- **D:1.0;** The download file version is 1.0.

Query	Reply	Definition of Reply
F	n.nn	Firmware version is n.nn
B	n.nn	Boot code version is n.nn
D	n.n	Download (fonts, graphics, formats) version is n.n

ESC{MY?} — Memory

This returns the size of all memory available in the printer, including the amount used and the amount remaining for the application.

Query Format

ESC{MY?}

Reply Format

{MY!FS:x;FM:x;RS:x;DT:x;DR:x}

Reply Example

{MY!FS:1M;FM:AMD;RS:1M;DT:049152;DR:000512}

- MY! This is a reply to a MEMORY query.
- FS:1M; This printer contains a 1 MB flash memory.
- FM:AMD; The Flash Manufacturer is AMD.
- RS:1M; RAM Size = 1 MB.
- DT:049152; Total Flash area available for Download is 49,152 bytes.
- DR:000512; Download Flash memory Remaining. Out of the 49,152 bytes, 512 bytes remain available.

Query	Reply	Definition of Reply
FS	1 MB, 4 MB	Flash size: 1 MB (128 KB) or 4 MB (512 KB)
FM	AMD	Flash manufacturer is AMD
RS	1 MB	RAM size is 1 MB (128 KB)
DT	nnnnnn	Download total area = nnnnnn bytes
DR	nnnnnn	Download RAM remaining = nnnnnn bytes

ESC{PH?} — Print Head

This returns the type of print head in use in this printer and the total number of dots across. This impacts the IMPACT2 (Epson) printers report as well as the number of pins on the print head and the column.

Query Format

ESC{PH?}

Reply Format

{PH!PINS:xx;W:xxx}

Reply Example

{PH!PINS:09;W:080}

- PH! This is a reply to a PRINTHEAD query.
- PINS:09; The print head has 9 pins.
- W:080; The width of this mode is 80 characters or columns.

Query	Reply	Definition of Reply
PINS	Nn	Total number of pins across this print head.
W	Nnn	Total number of characters or columns in this mode.

ESC{FN?} — Fonts

This returns a list of fonts, both permanent and downloaded. Within a complete font definition, each query character is separated from the next with a comma. A semicolon (;), carriage return <CR>, and line feed <LF> separates each font.

Query Format

ESC{FN?}

Reply Format

{FN!N5:x,N1:x,L:x,UV:x,UD:x,US:x,CPI:x}

Reply Example

```
{FN!N5:MF107,N1:&(26),L:R,UV:1,UD:01/02/03,US:96CHARS
BLOCKBOLD,CPI:10.7;N5:MF204,N1:!(21),L:D,UV:1,UD:01/02/03,
US:224 CHRBLOCK NORMAL,CPI:20.4}
```

- FN! This is a reply to a FONT query.
- N5:MF107, The first font has the name MF107.
- N1:&(26), The one-character name is “&” or 26H.
- L:R, The first font is a resident font.
- UV:1, The user version is 1.
- UD:01/02/03 The user date is 01/02/03.
- US:96CHARS BLOCKBOLD
The font is a 96-character block bold font.
- CPI:10.7 The font has 10.7 characters per inch.
- N5:MF204, The next font begins and is read similarly.

Query	Reply	Definition of Reply
N5	xxxxx	5-character name is “xxxxx.”
N1	x(nn)	1-character name — also in HEX.
L	R, D	Location: Resident (R) or Download (D)
UV	x	User version number
UD	mm/dd/yy	User month/day/year
US	x..x	(20 characters) Descriptive summary of font
CPI	nn.n	Characters per inch is nn.nn

ESC{RE!} — Reset

The response is the same as the command, after which the printer will reset and restart as though it had just been powered on.

PK80F Control Sequences



The following control sequences are for the PK80F Printer:

Note: Any time ESC is used in a command, the command needs to contain the actual ASCII character for ESC (0x1B), not the letters E-S-C. There should be no spaces before the next character. Sometimes a space is included in the documentation for readability.

Commands	Description
LF (0Ah) Line Feed	A single LF prints, advances paper, and places a carriage return at the end of the line. Multiple LFs continues to advance paper (or insert blank lines).
CR (0Dh) Carriage Return	A single CR prints and places carriage at end of line (no LF). With multiple CRs, all CRs after the first are ignored. <ul style="list-style-type: none"> • CR = print and position carriage at the end of line (no LF). • LF = print, advance one line, and place carriage at end of line. • CRLF = print and advance one line. • LFCR = print and advance one line. • CRCRCRCR. . .(<i>n</i> times) = print, place carriage at the EOL (no LF). • LFLFLFLF. . .(<i>n</i> times) = print and advance <i>n</i> lines.
FF (0Ch) Form Feed	This prints, advances paper to the top of the next page, and places a carriage return at the end of the line.
DEL (07h)	This cancels the previous character sent on that line.
SO (0Eh)	This sets the double wide mode (if <i>not</i> in the condensed mode) for one line only and cancels the condensed mode (if in the condensed mode).
SI (0Fh)	This sets the condensed mode (if <i>not</i> in the double wide mode) and cancels the double wide mode (if in the double wide mode).
DC2 (12h)	This sets the pica pitch mode and cancels the double wide, emphasized, and condensed modes.
DC4 (14h)	This cancels the double wide mode set by SO.
CAN (18h)	This cancels the current line without printing.
ESC SO	This selects the double wide mode for one line only.
ESC SI	This selects the condensed mode.
ESC DC2	This cancels the condensed mode.
ESC DC4	This cancels the double wide mode.
ESC @	This is the master reset, which resets the printer to its default states.
ESC ! <i>n</i>	Master select - each bit in <i>n</i> selects or deselects a feature: <ul style="list-style-type: none"> • All zeros — Select PICA • Bit 0 — Select ELITE • Bit 2 — Select Condensed (compressed) • Bit 3 — Select Emphasized (bold) • Bit 5 — Double Width (expanded) • Bit 6 — Italic • Bit 7 — Underline
ESC - <i>n</i>	This enables or disables the underline mode. If <i>n</i> =1, then enable the underline mode. If <i>n</i> =0, then disable the underline mode.

Commands (continued)	Description
ESC E	This enables the emphasized (bold) mode.
ESC EZ{	This sets the Easy Print mode and must include a curly bracket “{” to be compatible with the emphasized (bold) mode.
ESC F	This disables the emphasized (bold) mode.
ESC M	This sets the elite pitch mode, but does <i>not</i> cancel the double wide, emphasized, or condensed modes.
ESC P	This selects the pica pitch mode.
ESC W n	This enables or disables the double wide mode. If $n=1$, then enable the double wide mode. If $n=0$, then disable the double wide mode.
ESC w n	This selects the font with single character name n .
ESC s n	This initiates the print job status report where each individual bit in 'n' turns on or off one automatic report. See Chapter 4, “ <i>Troubleshooting</i> ” for information about the print job status report.
ESC e	This stops the print job status report.

Radio Queries

Bluetooth QUERY ESC{BL?}

This query returns information regarding the current configuration for Bluetooth.

Example

EX: ESC{BL?} returns {BL!AD:00:00:C7:80:3F:04;F:Wireless Printer;SN:4t Bluetooth;PR:SPP;CL:040680;D:Y;C:Y;B:Y;S:N;P:Y;PWR:ON}

Parameter	Description		
AD	Bluetooth Address as read from the card		
F	Friendly Name (such as Bluetooth Device Name)		
SN	Service Name		
PR	Profile (SPP = Serial Port Profile)		
CL	Class (040680 = Rendering, Imaging Printer)		
I	Responds with inactivity timer. "xxx" is the time in seconds before closing Bluetooth connection.		
D	Discoverable	Data	Description
		Y	Discoverable
		N	Not discoverable
C	Connectable	Data	Description
		Y	Connectable
		N	Not connectable
B	Bondable	Data	Description
		Y	Save bonding information
		N	Do not save bonding information
E	Encryption	Data	Description
		Y	Use encryption (<i>requires authentication</i>)
		N	No encryption
A	Authentication	Data	Description
		Y	Requires authentication
		N	No authentication
P	Passkey	Data	Description
		Y	Passkey present
		N	No passkey
PWR	Bluetooth Module Power	Data	Description
		ON	Power is ON.
		OFF	Power is OFF.

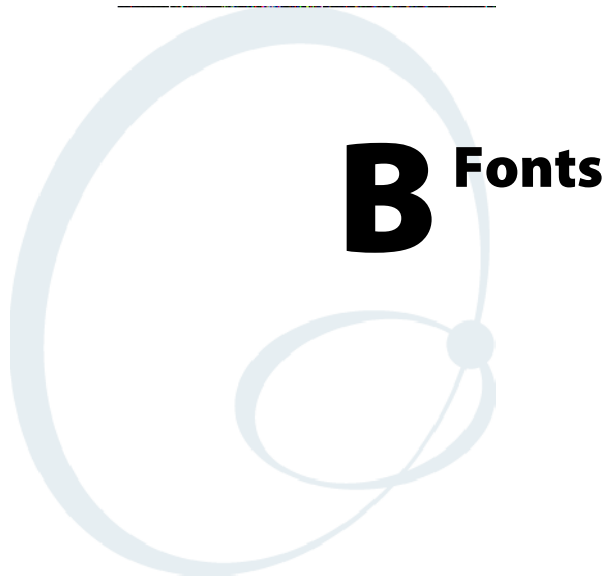

B Fonts

This appendix lists the information displayed on the printer self-test and displayed by the configuration tool used to load fonts.

Default Fonts

Name	Short Name	Description	Comments
PR437	A (41h)	255CH PICA CP437 REG	255 characters, pica pitch mode (10 cpi), Code Page 437
ER437	B (42h)	255CH ELIT CP437 REG	255 characters, elite pitch mode (12 cpi), Code Page 437
PI437	C (43h)	255CH PICA CP437 ITA	255 italics characters, pica pitch mode (10 cpi), Code Page 437
EI437	D (44h)	255CH ELIT CP437 ITA	255 italics characters, elite pitch mode (12 cpi), Code Page 437

Downloadable Fonts



Use the PK80 configuration program, Intermec MFlash, to download these fonts. See your Intermec representative for more information about this program.

Note: All these fonts are now loaded in your PK80 Printer at the factory.

Name	Short Name	Description	Comments
PR437	A	Code Page 437 255 char	Code Page 437 Pica
ER437	B	Code Page 437 255 char	Code Page 437 Elite
PI437	C	Code Page 437 Italics 224 char	Code Page 437 Italics Pica
EI437	D	Code Page 437 Italics Elite 224 char	Code Page 437 Italics Elite
ARABT	d	Bitstream Proportional 224 char	Arabic traditional
ARABS	e	Bitstream Proportional 224 char	Arabic simplified
ARABE	f	Epson Proportional 224 char	Arabic emapped simplified
GRDOS	g	Code Page Greek 224 char	Code Page (Greek)
GRWIN	h	Greek Windows 224 char	Windows Mapping (Greek)
ISO10	i	ISO 8859-1 255 char	ISO01 Pica Regular (draft)
ISO12	j	ISO 8859-1 255 char	ISO01 Elite Regular (draft)
PRI09	l	ISO 8859-9 192 char	ISO 8859-9 Pica Reg (Turkish)
ERI09	k	ISO 8859-9 192 char	ISO 8859-9 Elite Reg (Turkish)
HBISO	m	ISO 8859-8 192 char	ISO 8859-8 Pica (Hebrew)
HBDOS	n	DOS Code Page CP862	DOS Code Page 862 (Hebrew)
CY110	+	Code Page CP866 254 char	Code Page 866 (Cyrillic)
CY210	-	ISO 8859-5 255 char	ISO 8859-5 (Cyrillic)
DL210	^	Code Page 852 224 char	Code Page 852 Pica
DL212	_	Code Page 852 224 char	Code Page 852 Elite
DOS10	p	Code Page 437 with Eurosign	Code Page 437 (Latin) with Eurosign at 7F



C Graphics Printing

This appendix describes printing in the graphics mode, line spacing, and user-defined characters.

Graphics Overview

Graphics printing proceeds at the same rate as condensed printing. Printing at higher density does require two passes per line.

Pin Labels

The graphics mode requires a method to tell the printer which pins to fire in each column. Since there are 256 possible combinations of eight pins, you need a numbering system that allows you to use a single number to specify which of the 256 possible patterns you want.

- 128
- 64
- 32
- 16
- 8
- 4
- 2
- 1
- Not Used

Vertical spacing between dots is $1/72$ ".

You can fire any combination of pins by adding the appropriate values together. To fire any one pin, send its corresponding number. To fire more than one pin at the same time, add up the numbers of the pins and send the sum to the printer. For example, you fire the top pin by sending 128, or fire the bottom pin by sending 1. If you want to fire both the top and bottom pins, you send 129 ($128+1$).

Graphics Command Format

There are several different graphics commands offering a variety of horizontal dot densities and printing speeds. The format is similar for all the commands. Each command is an escape sequence corresponding to the graphics mode, followed by $n1$ and $n2$ to specify the number of columns reserved for graphics.

Column Reservation Numbers

Even in 60 DPI graphics mode, one 8" line can accommodate 480 columns of graphics; in 240 DPI graphics mode (quadruple-density), almost 2000 columns can fit on the same 8" line. Since the printer does not use decimal numbers larger than 255, the graphics commands use two numbers for reserving columns.

Because the commands are set up for two numbers, you must supply both, even if you need only one. When you need fewer than 256 columns, it is easy to determine $n1$ and $n2$. $n1$ is the number of columns you are reserving and $n2$ is zero. For example, to send data for 200 columns of graphics, $n1$ is 200 and $n2$ is 0.

For 256 or more columns of graphics data, $n2$ is the number of complete groups of 256 columns, and $n1$ is the number of leftover columns. For example, for 1632 columns of graphic data, $n1$ is 96 and $n2$ is 6 as $96 + (6 * 256) = 1632$.

Graphics Mode

Eight-Pin Graphics Modes

All 8-pin graphics functions require parameters, $n1$ and $n2$, which represent the length of the graphics string that follows the *Select Graphics Mode* command, and are calculated as follows (assuming a temporary variable n):

n = total number of graphics dots needed for the graphic string
 $n2$ = integer of (n divided by 256)
 $n1$ = remainder of the $n2$ calculation

The simplest calculation, is to divide n (total number of dots needed for the graphics string) by 256. Then $n2$ is the quotient (the whole number) and $n1$ is the remainder. If you require less than 256 dots (columns), then $n1$ indicates the number of dots and $n2$ is set to zero.

Nine-Pin Graphics Modes

These 9-pin graphics functions also require two parameters, $n1$ and $n2$. However, they are calculated slightly different than in the 8-pin graphics modes. Since each dot column to print must be represented by two data bytes, the total length of the graphic string (following the *Select ... Graphics Mode* command) first need to divide by 2. These parameters are calculated as follows (assuming a temporary variable n):

n = total number of dots needed, divided by 2
 $n2$ = integer of (n divided by 256)
 $n1$ = remainder of the $n2$ calculation

First, divide n (the total number of dots needed for the graphics string) by 2, then divide the result by 256. Then, $n2$ is the quotient (the whole number) and $n1$ is the remainder. If you require less than 256 dots (columns), then $n1$ indicates the number of dots and $n2$ is set to zero.

Pins are numbered 1–9, top to bottom, with byte 1 containing the information for pins 1–8. Pin 1 is the most significant byte (MSB) of byte 1. Byte 2 contains the information for pin 9 and is the MSB of this byte.

ESC K — Select Single-Density Graphics Mode

This control code sequence enables 8-pin single density graphics. The total number of dot columns to print is represented by $n1$ and $n2$, which indicates the length of the graphic string that immediately follows. The length of the graphic string must equal to $n1 + (n2 * 256)$. Graphic string data that exceeds the length of the print line is discarded. The maximum number of columns to print in this mode is 480.

Hexadecimal Format

1b 4b n1 n2

ESC L — Select Low-Speed Double-Density Graphics Mode

This control code sequence enables low-speed 8-pin double-density graphics. The total number of dot columns to print is represented by $n1$ and $n2$, which indicates the length of the graphic string that immediately follows. The length of the graphic string must equal $n1 + (n2 * 256)$. Graphic string data that exceeds the length of the print line is discarded. The maximum number of columns to print in this mode is 960.

Hexadecimal Format

```
1b 4c n1 n2
```

ESC Y — Select High-Speed Double-Density Graphics Mode

This control code sequence enables high-speed 8-pin double-density graphics. The total number of dot columns to print is represented by $n1$ and $n2$, which indicates the length of the graphic string that immediately follows. The length of the graphic string must equal $n1 + (n2 * 256)$. Graphic string data that exceeds the length of the print line is discarded. The maximum number of columns to print in this mode is 960. Ensure adjacent dots in a given dot row are not printed in graphic data design.

Hexadecimal Format

```
1b 59 n1 n2
```

ESC Z — Select Low-Speed Quadruple-Density Graphics Mode

This control code sequence enables low-speed 8-pin quadruple-density graphics. The total number of dot columns to print is represented by $n1$ and $n2$, which indicates the length of the graphic string that immediately follows. The length of the graphic string must equal $n1 + (n2 * 256)$. Graphic string data that exceeds the length of the print line is discarded. The maximum number of columns to print in this mode is 1920. Ensure adjacent dots in a given dot row are not printed in graphic data design.

Hexadecimal Format

```
1b 5a n1 n2
```

ESC ^ — Select 9-Pin Graphics Mode

This control code sequence enables 9-pin graphics. The variable m defines the density of the print where 0 equals single density and 1 equals double density. Since this is 9-pin graphics, two data bytes must represent each dot column to print. The total number of dot columns to print is represented by $n1$ and $n2$, which indicates the length of the graphic string divided by 2 that immediately follows. The length of the graphic string divided by 2 must equal $n1 + (n2 * 256)$. Graphic string data that exceeds the length of the print line is discarded. The maximum number of columns to print in this mode is 480 for single-density graphics and 960 for double-density graphics. Ensure adjacent dots in a given dot row are not printed in double-density graphics design.

Hexadecimal Format

1b 5e m n1 n2

ESC * — Select Graphics Mode

This control code sequence enables the graphic mode represented by the variable m as shown in the table below. The total number of dot columns to print is represented by $n1$ and $n2$, which indicates the length of the graphic string that immediately follows. The length of the graphic string must be equal $n1 + (n2 * 256)$. Graphic string data that exceeds the length of the print line is discarded.

Hexadecimal Format

1b 2a m n1 n2

Graphics Mode

Mode	m	Dots per Inch	Print Speed	Number of Passes
Single-density	0	60	200	1 (unidirectional)
Double-density	1	120	150	1 (unidirectional)
High-speed double-density *	2	120	200	1 (unidirectional)
Quadruple-density *	3	240	70	2 (unidirectional)
CRT I	4	80	150	1 (unidirectional)
Single-density plotter	5	72	150	1 (unidirectional)
CRT II	6	90	70	2
Double-density plotter *	7	144	70	2

* Note: Adjacent dots, in a given row, cannot print in this mode.

Draft mode is single pass, bi-directional, and prints at the highest speed because it never prints adjacent half dots.

Half dot modes must go slower.

Unidirectional modes can be fast or slow depending on dot adjacency.

High quality print modes are slower because they print adjacent dots.

Enhanced or double-strike modes require multiple passes.

ESC ? — Reassign Graphics Mode

This command sequence changes one graphics mode to another. The variable *s* is a character (K,L,Y, or Z) which is reassigned to a mode *n* (0–7).

Hexadecimal Format

1b 3f s n

ESC + — Print Character Graphics

This command sequence enables the printing of character graphics. The variable *n* is the length of the character graphics string. The variable *d* represents the character graphics data stream for a length of *n* characters. The value of the characters in the graphics data string may be from 0–255. With this command, certain character values 0–31 are printable graphics symbols rather than non-printable control codes. See *ESC I* for limitations.

Hexadecimal Format

1b 2b n d

ESC t — Print Character Graphics

The desired behavior is that this command is allowed for compatibility with the 6820 80-Column Printer but causes no action on the PK80 Printer. The default behavior for the PK80 Printer is *ESC t 1*, character graphics enabled. If any graphics characters are taller than nine dots, the printer advances the paper and prints the remaining dots. Any space advanced by the printer reduces the distance advanced by the printer when the next line-feed occurs.

However, if it is determined that this desired behavior too greatly impacts development time or printer speed, an allowable alternative is as follows:

This command sequence controls the printing of character graphics. When the variable *n* = 0, graphics characters taller than nine dots are truncated, only the top nine dots of the character are printed. When *n* = 1, graphics characters are printed in their entirety, the printer prints one line, then if necessary, advances the paper and prints another. Any space advanced by the printer reduces the distance advanced by the printer when the next line-feed occurs. The default mode is *ESC t 0*.

Hexadecimal Format

1b 74 n

Line Spacing

To print figures taller than eight dots on 9-Pin printers, the print head makes more than one pass. The printer prints one line, then advances the paper and prints another, just as it does with text.

To keep the print head from leaving gaps between the graphics lines as it does between the text lines, the line spacing must change to eliminate the space between lines. With a change in line spacing, you can produce finely detailed graphic images that give no indication that they are made up of separate lines.

ESC 0 — Select 1/8-inch Line Spacing

This control code sequence sets the line spacing to 1/8 of an inch for subsequent line-feed commands.

Hexadecimal Format

1b 30

ESC 1 — Select 7/72-inch Line Spacing

This control code sequence sets the line spacing to 7/72 of an inch for subsequent line-feed commands.

Hexadecimal Format

1b 31

ESC A — Select $n/72$ -inch Line Spacing

This control code sequence sets the line spacing to $n/72$ of an inch for subsequent line-feed commands. The variable n must be from 0–85.

Hexadecimal Format

1b 41 n

ESC 2 — Select 1/6-inch Line Spacing

This control code sequence sets the line spacing to 1/6 of an inch for subsequent line-feed commands. This is the default line spacing at power on.

Hexadecimal Format

1b 32

ESC 3 — Select $n/216$ -inch Line Spacing

This control code sequence sets the line spacing to $n/216$ of an inch for subsequent line-feed commands. The variable n must be from 0–255.

Hexadecimal Format

1b 33 n

Page Length

Set Page Length (lines)

The length of the paper is set, in lines, where the range of n (number of lines) is 1-127 (default = 66). Keep in mind the line spacing and actual length of the paper when specifying this value, since this function is dependent on those parameters. Top-of-Form is reset to the current line and the *Skip Over Perforation* setting is canceled.

Format

Decimal	Hex	ASCII
27 67 n	1B 43 n	ESC "C" n

Set Page Length (inches)

The length of the paper is set, in inches, where the range of n (number of inches) is 1-22 (default = 11). Keep in mind the line spacing and actual length of the paper when specifying this value, since this function is dependent on those parameters. Also, Top-of-Form is reset to the current line and the *Skip Over Perforation* setting is canceled.

Format

Decimal	Hex	ASCII
27 67 0 n	1B 43 00 n	ESC "C" NUL n

User-Defined Characters

To maintain 6820 Printer graphic compatibility, the PK80 Printer must also support user-defined characters. User-defined characters allow for the design of:

- New alphabets and typefaces
- Mathematical and scientific symbols
- Graphic patterns to serve as building blocks for larger designs

User-defined characters are stored in temporary memory (RAM). RAM-based definition, or redefinition, of standard characters is only allowed when the default SBCS code page is selected. There is no method to redefine characters in the other code pages since unique code pages can be created and loaded into the printer font memory (FLASH) for use. The following codes deal with user defined characters and their selection into memory

ESC : — Copy ROM to RAM

This command sequence copies the characters from ROM into RAM so that a complete user-defined character set is created by editing selected characters. This is helpful when user-defined character sets are selected so that all characters are defined. This eliminates the need to unselect the user-defined character set when printing characters that were not defined.

This command is only available when the default SBCS character set is selected.



Note: The three sets of zeros following the *ESC :* are part of the command.

Hexadecimal Format

```
1b 3A 00 00 00
```

ESC & — Define User-Defined Characters

This command sequence allows characters to redefine in the currently selected mode. Use this command in draft mode only. Any character from 0–255 may be redefined. Value *k1* is the character code of the first character to redefine. Value *k2* is the character code of the last character to define. Value *k1* may equal *k2* if only one character code is defined.

For each character defined, supply 12 bytes of data. The first byte (*s1*) describes the character format. The bottom four bits are the end position in the character grid. The next three bits represent the start position in the grid. Bit 7 represents whether the character uses the top eight pins or the bottom eight pins of the print head. When bit 7 = 0 the character uses the top eight pins. When bit 7 = 1, the bottom four bits are used.

The start and end positions are ignored during character imaging but must be accurate to redefine the character code.

The remaining bytes (*d1–d11*) are the data that comprises the dot image pattern of the defined character. Since a character can use up to 11 columns, you must supply 11 data numbers for each character even if some of the columns are blank. These are specified like the other print modes, left to right, with MSB as the top pin.

When printable code expansion is enabled via ESC I, and the user-defined character set is selected with ESC %, the following codes less than 20h may be defined for use and are printable:

Hexadecimal Format

```
1b 26 00 k1 k2 s1 d1 .. d11
```

Printable Code Expansion Characters

Hex	ASCII	Hex	ASCII
0	NUL	11	DC1
1	SOH	15	NAK
2	STX	16	SYN
3	ETX	17	ETB
4	EOT	1c	FS
5	ENQ	1d	GS
6	ACK	1e	RS
10	DLE	1f	US



Note: This command is only available when the default SBCS character set is selected.

ESC % — Select User-Defined Set

This command sequence selects the user-defined character set when the variable *n* = 1 and ESC % defines the character set. A value of *n* = 0 selects the normal character set.

Hexadecimal Format

```
1b 25 n
```



Note: This command is only available when the default SBCS character set is selected.

ESC 6 — Enable Printing of Codes 128–159

This command is allowed for compatibility with the 6820 Printer but causes no action on the PK80 Printer. The default behavior for the PK80 Printer is that codes 128–159 are printable characters rather than control codes.

Hexadecimal Format

```
1b 25 n
```



Note: This command is only available when the default SBCS character set is selected.

ESC 7 — Cancel Printing of Codes 128–159

This command is allowed for compatibility with the 6820 Printer but causes no action on the PK80 Printer. Unlike the 6820 Printer, the default for the PK80 Printer is *ESC 6*, not *ESC 7*.

Hexadecimal Format

1b 37



Note: This command is only available when the default SBCS character set is selected.

ESC I — Printable Code Area Expansion

This command sequence allows certain ASCII codes 0 to 1Fh to be printable when the variable *n* is set to 1. This allows the use of these codes for user-defined characters. If *n* = 0, the command returns 0 to 1Fh to non-printable control codes. Only the following codes can be redefined as printable characters. Codes not listed print as standard control codes.

Hexadecimal Format

1b 49 n

Printable Code Expansion Characters

Hex	ASCII	Hex	ASCII
0	NUL	11	DC1
1	SOH	15	NAK
2	STX	16	SYN
3	ETX	17	ETB
4	EOT	1c	FS
5	ENQ	1d	GS
6	ACK	1e	RS
10	DLE	1f	US



Note: This command is only available when the default SBCS character set is selected.



Corporate Headquarters
6001 36th Avenue West
Everett, Washington 98203
U.S.A.

tel 425.348.2600

fax 425.355.9551

www.intermec.com

PK80 Series 80-Column Printer User's Manual - February 2005



P/N 961-018-004 REV F

Free Manuals Download Website

<http://myh66.com>

<http://usermanuals.us>

<http://www.somanuals.com>

<http://www.4manuals.cc>

<http://www.manual-lib.com>

<http://www.404manual.com>

<http://www.luxmanual.com>

<http://aubethermostatmanual.com>

Golf course search by state

<http://golfingnear.com>

Email search by domain

<http://emailbydomain.com>

Auto manuals search

<http://auto.somanuals.com>

TV manuals search

<http://tv.somanuals.com>