

V/Ethernet 4221 Condor User's Guide

Document No. UG04221-000, REV B
Release date: July 1994

Copyright 1994
Interphase Corporation
All Rights Reserved

Copyright Notice

Copyright 1993, 1994 by Interphase Corporation

All rights reserved

No part of this publication may be stored in a retrieval system, transmitted, or reproduced in any way, including, but not limited to photocopy, photograph, electronic, or mechanical, without prior written permission of:

Interphase Corporation

13800 Senlac

Dallas, Texas 75234

Phone: (214) 919-9000

FAX: (214) 919-9200

Disclaimer

Information in this user document supercedes any preliminary specification, data sheets, and/or any other documents that may have been made available. Every effort has been made to supply accurate and complete information. However, Interphase Corporation assumes no responsibility or liability for its use. In addition, Interphase Corporation reserves the right to make product improvement without prior notice. Such improvements may include, but not limited to, command codes and error codes.

For Assistance

To place an order for an Interphase product, call:

Sales Support: (214) 919-9000

For assistance using this, or any other Interphase product, call:

Customer Service: (214) 919-9000

United Kingdom: +44-869-321222

To send in a board for repair or upgrade, call:

RMA Coordinator: (214) 919-9000

Trademark Acknowledgments

All terms used in this manual that are known to be trademarks or service marks are listed below. In addition, terms suspected of being trademarks have been appropriately capitalized. Use of a term in this manual should not be regarded as affecting the validity of any trademark or service mark.

- Interphase is a registered trademark of Interphase Corporation.
- Virtual Buffer ArchitectureSM, BUSpacket InterfaceSM, and CacheFlowSM are service marks of Interphase Corporation.
- UNIX® is a registered trademark of AT&T Bell Laboratories.
- IBM® is a registered trademark of International Business Machines.
- 80486® 82503®, and 82596A® are registered trademarks/product marks of Intel.
- MC68EC030® and MC68040® are registered trademarks/product marks of Motorola.

TABLE OF CONTENTS

CHAPTER 1

INTRODUCTION	1
Intended Audience	1
Scope Of Manual	1
References	1
Conventions	2
General Description	2
Features	2
Options	3
Physical Description	3
Functional Description	3
Ethernet Front End Channel (FEC)	4
VMEbus Master Interface	4
DMA Engine	4
VMEbus Drivers And Receivers	4
Local Bus	4
VMEbus Short I/O Interface	5
CPU Core	5
CPU/LBUS Interface	6

CHAPTER 2

HARDWARE INSTALLATION	7
Overview	7
4221 Condor Hardware Installation Procedures	14
Step 1. Visual Inspection	14
Step 2. Fuse And Diagnostic LEDs	14
Step 3. Set Onboard Motherboard Jumpers	16
Step 4. Set Daughter Card Jumpers And Terminations	47
Step 5. Power Off System	51
Step 6. Cabling Procedure	51

CHAPTER 3

MACSI HOST INTERFACE	53
Introduction	53
Typographic Convention	53
Memory Address	53
Field Offset	54
Contiguous Data Allocation	54
System Interface	55
MACSI Organization	55
Master Control Status Block (MCSB)	57
Master Status Register (MSR)	57
Master Control Register (MCR)	58
Onboard Command Queue Entry	59
Queue Entry Control Register (QECR)	59
IOPB Address	60
Command Tag	60
Work Queue Number	60
Offboard Command Queue Entry	60
Queue Entry Control Register (QECR)	60
DMA Transfer Control Word	61
Host Address	61
Offboard Transfer Length	61
Work Queue Number	61

Command Response Block (CRB)	62
Command Response Status Word (CRSW)	62
Command Tag	63
IOPB Length	63
Work Queue Number	63
Multiple Completed Returned IOPB Structure	64
Command Tag	64
Port	64
Work Queue Number	64
Transfer Count	64
Configuration Status Block (CSB)	65
Product Code	65
Product Variation	65
Firmware Revision Level	66
Firmware Revision Date	66
Ethernet MAC Addresses (Ports 0 - 3)	66
Controller Statistics Block	67
Transmit Commands Submitted	68
Transmit DMA Completions	68
Transmit 82596 Completions	68
Successful Transmits	68
Failed Transmits	68
Transmit Completions Posted to Host	69
Receive Commands Submitted	69
Receives Dropped - No Pending Receive Command	69
Receive 82596 Completions	69
Failed Receives	69
Receive DMA Completions	69
Receive Completions Posted to Host	69
IO Parameter Blocks (IOPBs)	70
Common IOPB Structures	70
Command Code	71
Command Options	71
Return Status	71
Normal Completion Level / Vector	71
Error Completion Level / Vector	71
DMA Transfer Control Word	71
Initialize Controller	73
Command Code	73
Controller Initialization Block Offset	73
Controller Initialization Block (CIB)	74
Number of CQE Entries	74
Special Network Options	75
Ethernet Physical Node Addresses	75
Interrupt Levels and Vectors	75
DMA Burst Count	75
Offboard CRB DMA Transfer Control Word	76
Offboard CRB host address	76
MAC Control/Status	77
Command Code	78
Command Options	79
Return Status	80
Buffer address	80
Transfer size	80

MAC status/control	80
Intel 82596 Status/Control – Transmit Functions	81
Intel 82596 Status/Control – Receive Functions	82
MAC returned information	84
Change Default Node Address	85
Command Code	85
Command Options	86
Transmit	87
Command Code	87
Command Options	88
Transmit -- In-Line Gathers	88
Number of Elements	89
Total transfer count	89
Element transfer count	89
Buffer address	89
Receive	90
Command Code	91
Command Options	91
Buffer Address	91
Maximum / Actual Transfer Size	91
Packet Type / Length Field	91
Source Address	92
Initialize Multiple Completions	93
Command Code	93
Command Options	94
Return Status	94
Control Flags	94
Group Interrupt Level / Vector	94
Minimum Group Count	94
Maximum Group Count	94
Report Network Statistics	95
Command Code	95
Command Options	96
Return Status	96
Host Memory Buffer Address	96
Max Transfer Size	96
Timer Interval	96
Network Statistics Block	97
Data Valid Indicator	97
Port Indicator	97
Transmits Submitted	97
Transmits Completed	97
Transmits Failed	98
Collisions	98
Receives Submitted	98
Receives Returned	98
Receives Dropped (Resources)	98
Receives Dropped (Errors)	98
APPENDIX A	
SPECIFICATIONS	99
VMEbus Specifications	99
Power Requirements	99
Mechanical (Nominal)	100

Operating Environment 100
Fuse 100
Reliability 100

APPENDIX B

CONNECTOR PINOUTS AND CABLING 101
Overview 101
VMEbus Connectors 102
Ethernet Connectors and Pinouts 104
RS232 Connector and Cable 106

APPENDIX C

ERROR CODES 107

LIST OF FIGURES

Figure 1-1.	4221 Condor Block Diagram	3
Figure 2-1.	10BaseT Condor Motherboard Layout (PB04221-000)	9
Figure 2-2.	Single Channel AUI or 10BaseT Motherboard Layout (PB004221-001)	10
Figure 2-3.	AUI Condor Motherboard Layout (PB04221-000)	11
Figure 2-4.	10BaseT Condor Motherboard Layout (PB04221-001)	12
Figure 2-5.	AUI Condor Motherboard Layout (PB04221-001)	13
Figure 2-6.	Ethernet Single Channel AUI/10BaseT Daughter Card	48
Figure 2-7.	Dual Channel 10BaseT Ethernet Daughter Card	49
Figure 2-8.	Ethernet Dual Channel AUI Daughter Card	50

LIST OF TABLES

Table 2-1.	Condor Products	8
Table 2-2.	4221 Condor LEDs.	14
Table 2-3.	Board Status Diagnostics Used In POST Mode.	15
Table 2-4.	Run Mode LED Matrix	16
Table 2-5.	VME Bus Grant Settings.	17
Table 2-6.	Secondary Short I/O	19
Table 2-7.	Primary Short I/O Size	19
Table 2-8.	Primary Base Address For 2K Short I/O	22
Table 2-9.	Primary Base Address For 1K Short I/O	23
Table 2-11.	Primary Base Address For 256 Byte Short I/O	26
Table 2-12.	Secondary Base Address For 2K Short I/O.	34
Table 2-13.	Secondary Base Address For 1K Short I/O	35
Table 2-14.	Secondary Base Address For 512 Byte Short I/O	37
Table 2-16.	Ethernet Single Channel Daughter Card LEDs.	48
Table 2-17.	Dual Channel 10BaseT Ethernet Daughter Card LEDs	49
Table 2-18.	Ethernet Dual Channel AUI Daughter Card LEDs	50
Table 2-19.	Ethernet Cable Options	51
Table 3-1.	MACSI Memory Map	55
Table 3-2.	Master Control Status Block	57
Table 3-3.	Master Status Register	57
Table 3-4.	Master Control Register	58
Table 3-5.	Onboard Command Queue Entry	59
Table 3-6.	Queue Entry Control Register	59
Table 3-7.	Offboard Command Queue Entry	60
Table 3-8.	Command Response Block	62
Table 3-9.	Command Response Block	62
Table 3-10.	Multiple Completed Returned IOPB Structure	64
Table 3-11.	Configuration Status Block	65
Table 3-12.	4207 Eagle Controller Statistics Block	67
Table 3-13.	IOPB Commands	70
Table 3-14.	Common IOPB Structures	70
Table 3-15.	Command Options	71
Table 3-16.	DMA Transfer Control Word.	71
Table 3-17.	Memory Type.	72
Table 3-18.	Transfer Type.	72
Table 3-19.	Initialize Controller	73
Table 3-20.	Controller Initialization Block	74
Table 3-21.	Special Network Options	75
Table 3-22.	MAC Control / Status.	78
Table 3-23.	Command Options	79
Table 3-24.	MAC Status / Control.	80
Table 3-25.	Intel 82596 Transmit Status / Control	82
Table 3-26.	Intel 82596 Receive Status / Control	83
Table 3-27.	Change Default Node Address.	85
Table 3-28.	Command Options	86
Table 3-29.	Transmit	87
Table 3-30.	Command Options	88
Table 3-31.	Transmit - In-Line Gathers.	89
Table 3-32.	Receive.	90
Table 3-33.	Command Options	91
Table 3-34.	Common IOPB Structures	93
Table 3-35.	Control Flags	94

Table 3-36.	Report Network Statistics	95
Table 3-37.	Command Options.	96
Table 3-38.	Network Statistics Block	97
Table C-39.	P1 Connector Signal Descriptions (All Versions).	102
Table C-40.	P2 Connector For Motherboards Which Only Uses P2 Row B	103
Table C-41.	RJ45 (10BaseT) Connector Signals	104
Table C-42.	DB15 (AUI) Connector Signals	105
Table C-43.	Serial Connector Pinouts (SPA and SPB)	106
Table C-44.	Suggested RS232 Cable Pinout.	106

CHAPTER 1

INTRODUCTION

Intended Audience

Interphase wrote this manual for its customers. It is intended for a highly technical audience, specifically, users who need to write their own software drivers.

Readers are assumed to have extensive knowledge of the following:

- The C programming language, including experience writing and installing interface software (drivers).
- The operating system of the host computer.
- Ethernet specifications.
- VME specifications.

Scope Of Manual

The manual organization allows the user to focus on specific areas of interest, without giving more information than needed.

Specifically, this manual contains guidelines on:

- Installing the V/Ethernet 4221 Condor.
- Programming the V/Ethernet 4221 Condor, single through four port operation.
- Determining the cause of any error messages generated by the board.

References

- VMEbus Specification, Revision C
- VMEbus Revision D, Draft 3.02, October 8, 1990
- IEEE 802.3 CSMA/CD, 1985
- Supplements to IEEE 802.3 CSMA/CD Local Area Network, 1988 through 1993
- 32 Bit Local Area Network (LAN) Component User's Manual, Intel, 1992, Order No. 296853-001

Conventions

This section details many of the writing conventions used throughout the manual. In addition, it gives many of the technical conventions.

- The V/Ethernet 4221 Condor will be referred to by the name *Condor* or referenced as the *controller*.
- Byte represents 8 bits; word represents 16 bits (2 bytes); and longword represents 32 bits (2 words, 4 bytes).
- Binary (single bit) data is represented as either 1 or 0.
- To represent hexadecimal numbers, the manual adopts the C language notation. Decimal numbers are shown as decimal digits. For example:

0x29 = 29 hex
41 = 41 decimal

- Used in the context of a single bit of data, the term set means that the bit is a one ("1").
- Similarly, the term cleared means that the bit is a zero ("0").
- In many cases, bits, bytes, and words are marked RESERVED. If the value of the reserved bit, byte, or word is sent to the controller by the host, the value must be cleared to 0.
- If the reserved value is returned by the controller, it is reserved for future use by Interphase. The user should not rely on these values to be consistent through different revisions of the product.

General Description

The Condor is the second-generation multi-channel multi-function I/O Host Bus Adapter (HBA) for the VMEbus in the Cougar product line. The board is designed to maintain scalable performance and cost. The Condor architecture can be implemented with up to four Front End Channels (FECs). The FECs interface directly to a local bus, which contains a large memory buffer and a VMEbus DMA engine. This board also contains a CPU core with its own memory area and host bus interface.

Features

The basic functions and features supported by the Condor are as follows:

- Dual Ethernet Channel (10baseT or AUI) on the Motherboard.
- Dual Ethernet Channel (10baseT or AUI) on the Daughter Card.
- 8-, 16-, 32- and 64-bit VMEbus Master DMA capability.
- 25 Mbytes/second master mode burst/sustained D32 transfer rate across the VMEbus (in some modes).
- 50 Mbytes/second master mode burst/sustained D64 transfer rate across the VMEbus (in some modes).
- Programmable VME/interrupt levels and vectors.
- 16-bit, 24-bit, and 32-bit VMEbus DMA addressing, and all addressing modifiers.
- Software programmable VMEbus priority levels.
- Two VMEbus configurable 2K byte short I/O access areas of 8-bit, 16-bit, and 32-bit Slave mode transfers.

Options

Interphase Corporation offers the following Condor options:

- Dual Channel Ethernet (AUI)
- Dual Channel Ethernet (10BaseT)
- 3 Channel Ethernet (AUI or 10BaseT)
- Quad Ethernet Channel (AUI or 10BaseT)

Physical Description

The Condor physically conforms to the 6U VMEbus board standard. The board requires the VMEbus +5 (+/- 5%) volt supply. The board supports two channels on the main board with the associated channel connectors and up to two channels on daughter card. The cable connectors for the channels on the daughter cards reside on the daughter cards. See Appendix A for a detailed list of the Condor's physical requirements and specifications.

Functional Description

The Condor as shown in the block diagram (Figure 1-1.) consists primarily of four front-end channels, a VMEbus Master Interface, a Local Bus (LBUS), a VMEbus Short I/O (slave only) Interface, a CPU Core and a CPU/Local bus interface.

Each Ethernet Front End Channel (FEC) consists of an Ethernet controller, the associated Ethernet cable connections, front end circuitry and a small amount of Local Bus interface glue logic. The VMEbus Master Interface consists of a stand-alone VLSI DMA engine and the associated VMEbus high current driver and receiver devices. The Local Bus (LBUS) consists of the memory buffer and the associated handshake logic for the bus. The VMEbus Short I/O interface consists of the handshake and buffer logic for the host system to issue commands to the board. The CPU Core consists of a CPU with the associated memory and glue logic required to allow the CPU to control the functions of the Condor board. Finally, the CPU/Local Bus interface consists of the tri-state buffers and handshake logic required to allow the CPU to access the resources on the LBUS.

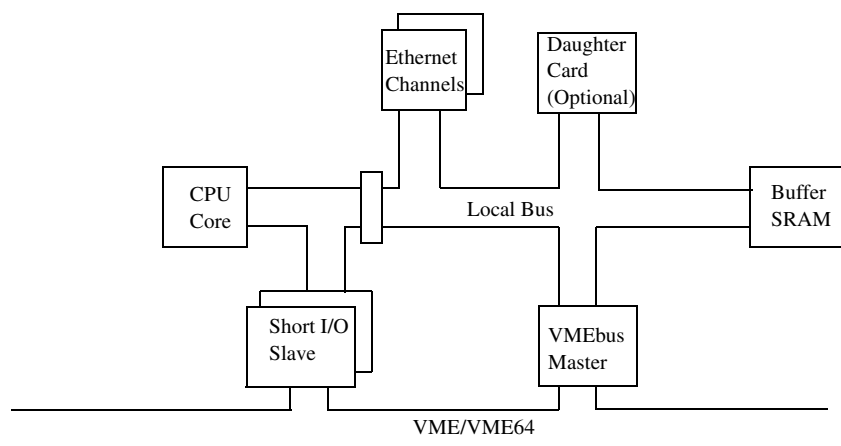

Figure 1-1. 4221 Condor Block Diagram

Ethernet Front End Channel (FEC)

The 82596CA® Local Area Network (LAN) Co-processor is used as the FEC Ethernet controller. The 82596CA® communicates with the rest of the board through the LBUS. The 82596CA® has a 80486® type bus interface, which requires two PALs to convert the 80486® interface to meet the LBUS (MC68040_ type) specification. The 82596CA® can be a master or a slave of the LBUS. As a LBUS master, the 82596CA® accesses both data and command lists for both transmits and receives commands. As a slave, the CPU has write access to four locations within the 82596CA® to establish a software reset or initialization and reset test pointers.

To complete the connections to the Ethernet cable, the 82596CA® connects to the encoder/decoder interface device (82503®) which in turn connects through analog circuitry to the cable connectors. The encoder/decoder and analog circuitry provides support for both 10BaseT and the Attachment Unit Interface (AUI).

VMEbus Master Interface

The VMEbus Master Interface consists of a VLSI DMA engine and the required high current VMEbus driver and receiver devices.

DMA Engine

The DMA engine interfaces the LBUS with the VMEbus and performs the LBUS to VMEbus DMA functions. The DMA engine communicates with the rest of the board through the LBUS. The DMA engine can be a master and a slave of the LBUS. As a LBUS master, the DMA engine accesses linked list DMA commands as well as buffered data. As a LBUS slave, the DMA engine is accessed by the CPU for configuration and status information.

The DMA engine provides the VMEbus interrupter support logic, some of the internal CPU interrupts (with vectors) and the board timers.

The DMA engine also provides many functions and features which are not currently used on the Condor board. These functions include a non-DMA LBUS to VMEbus interface, VMEbus slave to LBUS interface, system controller functions, an interrupt handler and several global general purpose registers.

VMEbus Drivers And Receivers

External buffers are used to provide a more isolated and robust interface to the VMEbus. These buffers drive and receive most of the VMEbus data, address and control lines.

Local Bus

The Local Bus (LBUS) is based primarily upon a MC68040® CPU bus structure. The channels and functions connected to the LBUS must conform to the MC68040_ bus specification. This allows easy design and development of a wide variety of front ends and back ends into the controller board.

The LBUS encompasses the actual bus itself, the buffer memory and all of the logic which is not associated with any one particular channel (front end or back end) on the LBUS.

The buffer memory is configured as two SRAM banks which consists of four SRAM devices for each bank. The two banks of SRAM combined provide for 128K-, 256K-, 512K- and 1M-byte of memory.

The LBUS logic consists of an arbiter, an address decoder, a burst mode address counter, a write strobe generator, a transfer acknowledge generator, a SRAM buffer memory and any miscellaneous handshake logic required to connect the channels to the LBUS.

VMEbus Short I/O Interface

The VMEbus Short I/O interface allows for VMEbus host and onboard CPU communications. The host issues commands to the Condor through the Short I/O interface and the CPU issues status back to the host.

The Short I/O Interface is a Slave-only interface to the Condor and contains two independent, jumper-configurable, slave-access areas. The areas can be configured to be 256, 512-, 1K- or 2K- bytes in length.

VMEbus address lines A(15-08) and the Address Modifier lines are compared with the jumper-configurable, slave-access areas. Address Modifiers "2D" and "29" are supported for the Short I/O access.

The Short I/O Mailboxes physically reside in the CPU Core SRAM. The reset and mailbox location monitor logic resides in the VMEbus Short I/O Interface.

CPU Core

The CPU (and core logic) controls and configures the rest of the Condor. Each of the commands issued to the FECs and the VMEbus DMA engine are issued by the onboard CPU.

The CPU Core consists of a MC68EC030 CPU and associated support logic. The CPU Core support logic includes the following:

- EPROM/FLASH
- Serial EPROM
- SRAM
- DUART Port
- Address Decoder
- Wait State Generator
- STERM/DSACK Generator
- Control/Status Registers
- Hardware Strobes
- Clock Generation
- Interrupt Handler
- FLASH ROM Hardware

The program for the CPU is stored in a single-byte-wide, EPROM (or FLASH) device. The EPROM can be 128K-, 256K- or 512K- bytes in size. There are two SRAM banks which consists of four SRAM devices for each bank. The two banks of SRAM combined provide for 128K-, 256K, 512K- and 1M-byte of SRAM. At board power-up, the program is copied from the EPROM (or FLASH) device to the SRAM banks. The program is then executed from the higher performance SRAM devices.

The interrupt-handler logic combines the three level interrupt from the DMA engine and the non-DMA engine-interrupt sources and outputs the three-level interrupt signals to the CPU. During CPU IACK cycles, the

interrupt handler outputs an interrupt vector number for the non-DMA engine interrupts or requests access to the LBUS for a DMA engine IACK cycles.

CPU/LBUS Interface

The CPU/LBUS Interface links the CPU core with the LBUS resources. The CPU/LBUS interface converts the CPU Core bus to the LBUS. The Interface is a one-way interface which allows the CPU to act as a LBUS master. The interface does not allow other LBUS masters to access the CPU Core.

The CPU/LBUS interface is composed of address latches, data-latching transceivers, and control logic. The CPU/LBUS Interface performs write-posting and read-latching to maximize the CPU bus and the LBUS performance. The interface also performs relinquish retries, read-modify-write cycles, IACK cycles to the DMA engine, back-to-back write-write cycles and back-to-back, write-read cycles.

CHAPTER 2

HARDWARE INSTALLATION

Overview

Before attempting installation, read this chapter thoroughly to insure the safe installation of the Condor into your system. If you have any questions regarding installation, which are not answered in this chapter, please contact Interphase Customer Service at (214) 919-9111.

The Condor is installed into the VMEbus system using the following steps:

- Visual Inspection
- Fuse And Diagnostic LEDs
- Set Onboard Jumpers
- Set Daughter Card Jumpers
- Power Off System
- Installing the Board
- Cabling Procedure

When installing the Condor, heed the following **WARNING**:

WARNING

1. Catastrophic **DAMAGE** can result if improper connections are made. Therefore, those planning to connect power sources to the VMEbus for the purpose of feeding the user-defined 96 pins of P2 (Rows A and C) should **FIRST CHECK** to ensure that all boards installed are compatible with those connections.
2. Do **NOT** install, or apply power to, a damaged board. Failure to observe this warning could result in extensive damage to the board and/or the system.
3. **CAUTION!** The Condor is extremely sensitive to electrostatic discharge (ESD), and the board could be damaged if handled improperly. Interphase ships the board enclosed in a special anti-static bag. Upon receipt of the board, take the proper measures to eliminate board damage due to ESD (i.e., wear a wrist ground strap or other grounding device).

The daughter card installation procedure will vary depending on the desired configuration. Variables include:

- Single Channel AUI/10BaseT.
- Dual Ethernet AUI.
- Dual Ethernet 10BaseT.

The following table summarizes the Condor products that are available from Interphase to implement various combinations of the above functions.

Table 2-1. Condor Products

Product	Description
10BaseT Condor Motherboard (P2 Row B Only)	Provides Dual and/or Single 10BaseT Ethernet connections. This board only uses row B of the P2 connector.
Single Channel AUI/10BaseT Motherboard	Provides Single AUI or 10BaseT Ethernet connections.
AUI Condor Motherboard	Provides Dual AUI Ethernet connections. This board only uses row B of the P2 Connector.
Dual AUI Ethernet Daughter Card	Adds dual AUI connections to any of the above motherboards.
Dual 10BaseT Ethernet Daughter Card	Adds Dual 10BaseT connections to any of the above motherboards.
Single Channel AUI/10BaseT Daughter Card	Adds a single AUI or 10BaseT channel to any of the above motherboards.

The following figures outline the board layout and jumper positions for the two different motherboard configurations:

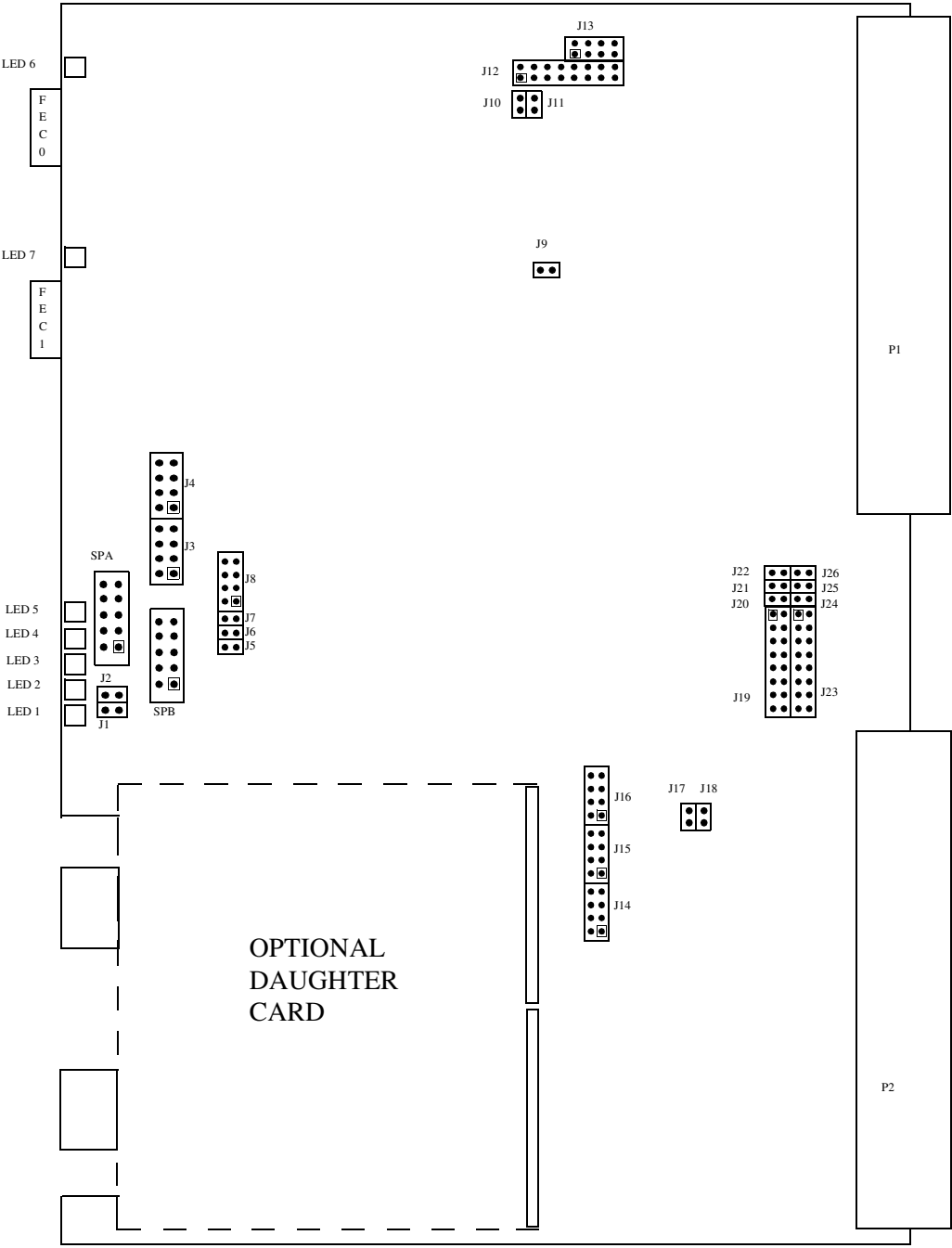

Figure 2-1. 10BaseT Condor Motherboard Layout (PB04221-000)

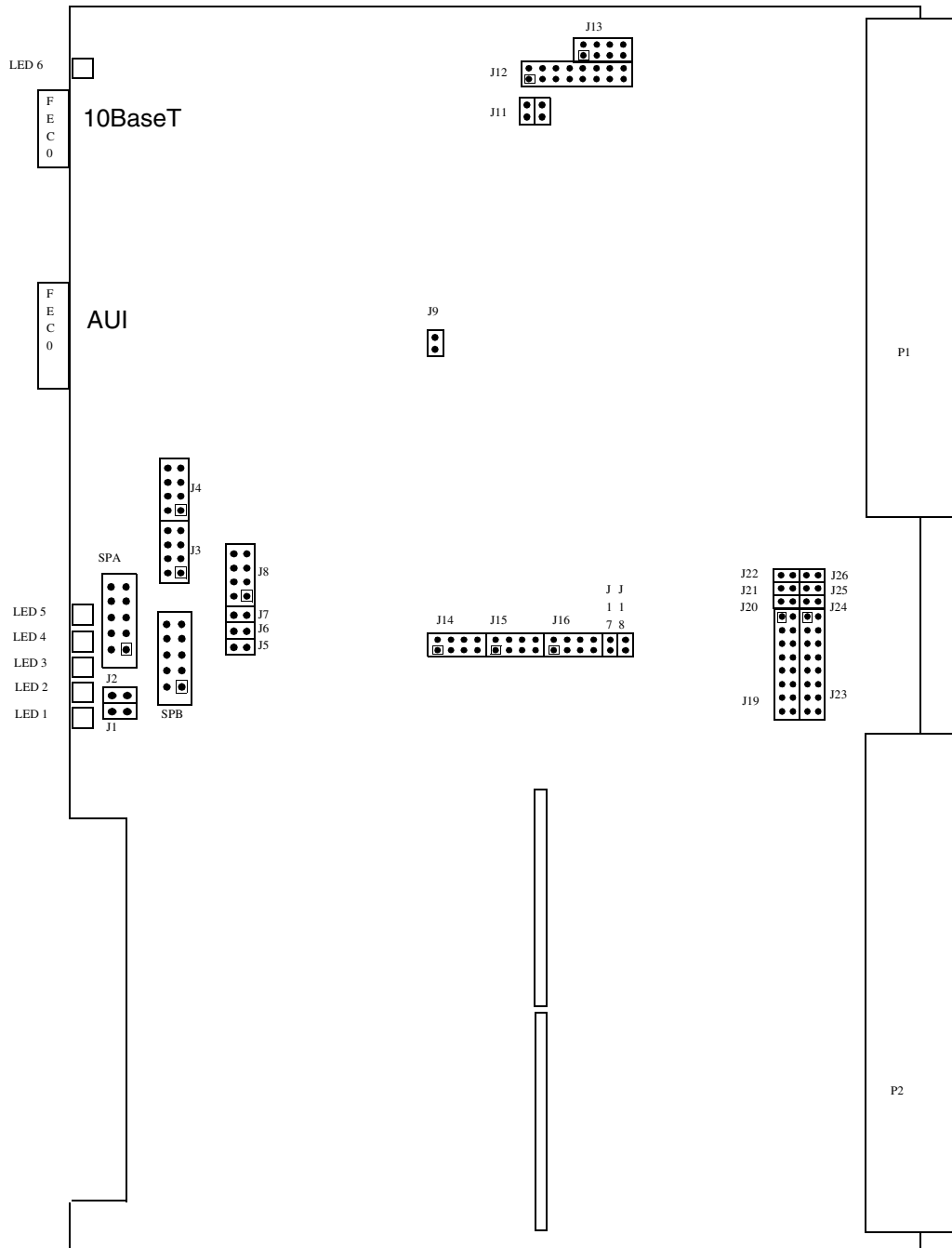

Figure 2-2. Single Channel AUI or 10BaseT Motherboard Layout (PB004221-001)

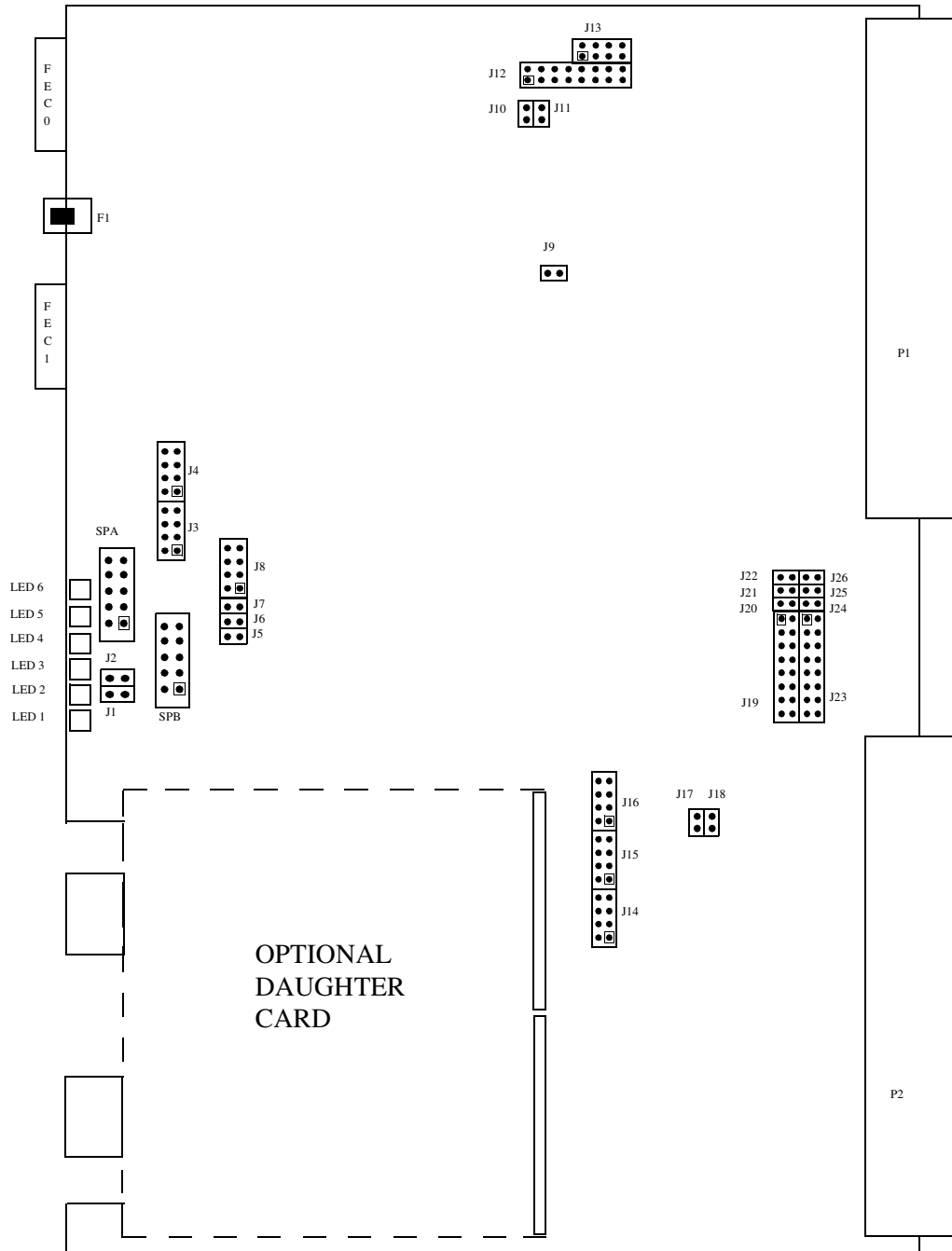

Figure 2-3. AUI Condor Motherboard Layout (PB04221-000)

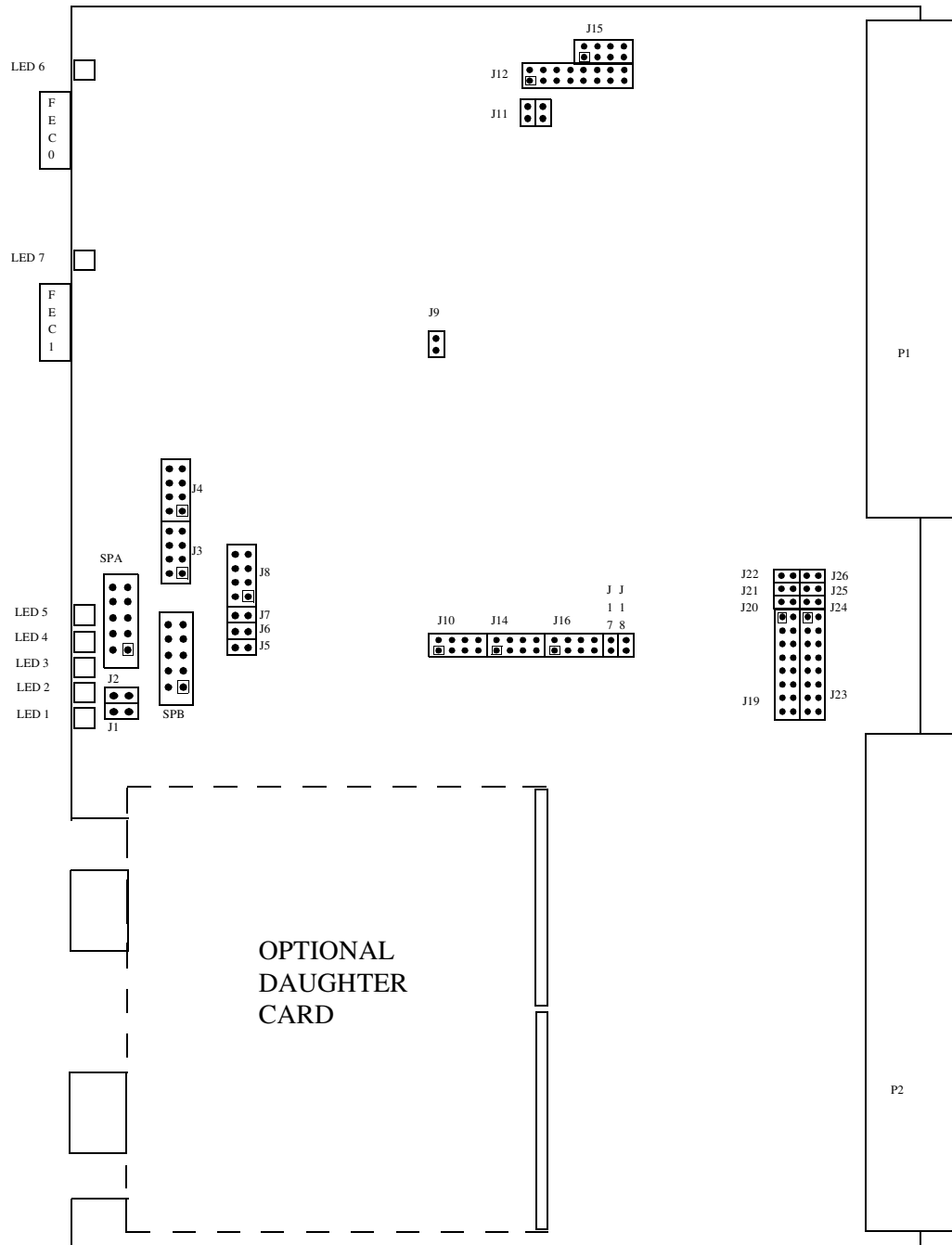

Figure 2-4. 10BaseT Condor Motherboard Layout (PB04221-001)

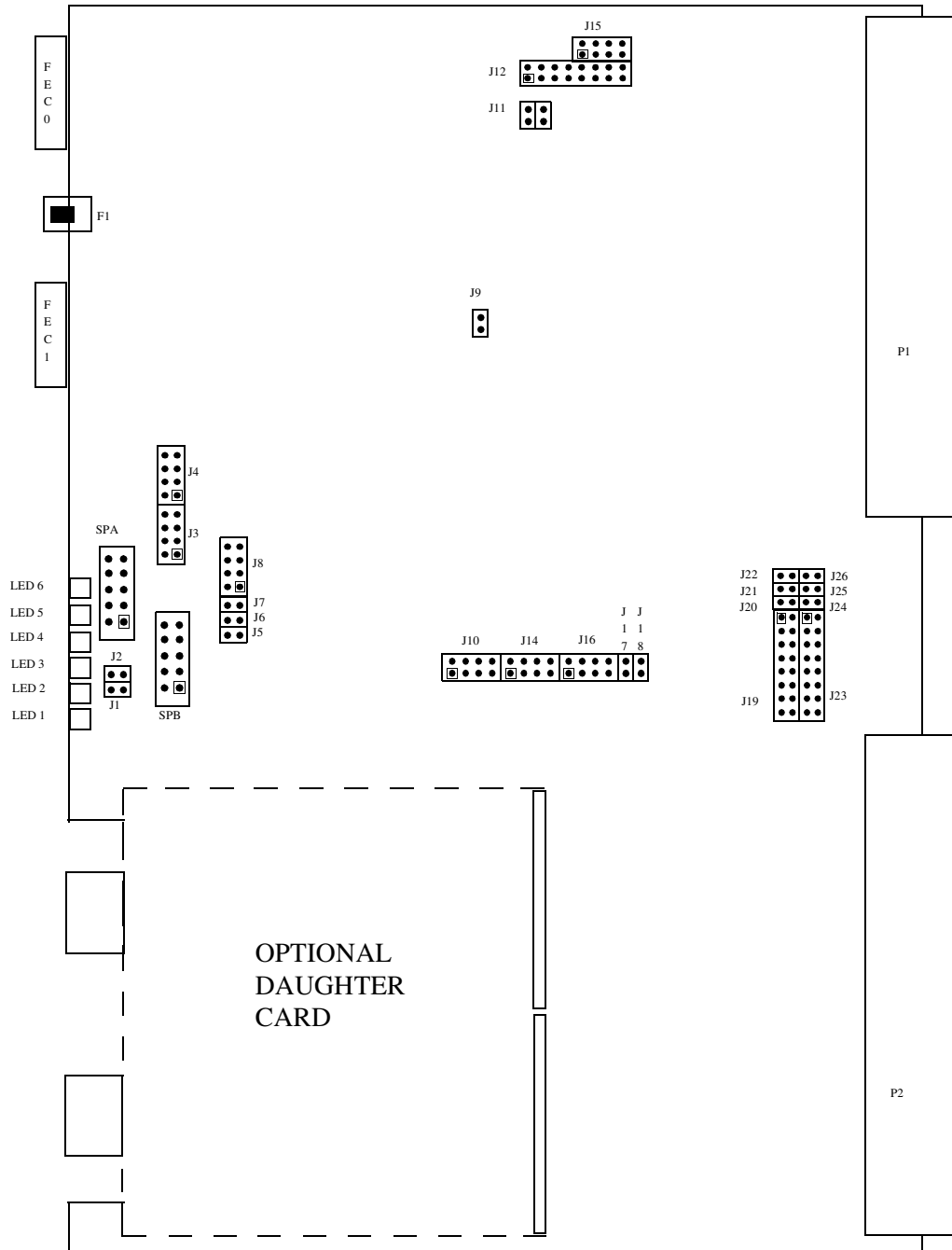

Figure 2-5. AUI Condor Motherboard Layout (PB04221-001)

4221 Condor Hardware Installation Procedures

For proper installation of the Condor, it is imperative that you use the following procedures.

Step 1. Visual Inspection

Before attempting the installation of this board, make sure you are wearing an anti-static or grounding device. Remove the Condor board from the anti-static bag, and visually inspect it to ensure no damage has occurred during shipment. A visual inspection usually is sufficient, since each board is thoroughly checked at Interphase just prior to shipment.

If the board is undamaged and all parts are accounted for, proceed with the installation.

Step 2. Fuse And Diagnostic LEDs

The following discusses the fuse, diagnostic LEDs, and board status LEDs.

Fuse

The AUI version of the Condor has a 1.5A fuse (F1) used to protect the +12 volts when provided by the Condor. Its part number is LITTLEFUSE 273-01.5. To determine the location of the fuse on the board, refer to the appropriate board layout.

Diagnostic LEDs

The Condor has as many as 8 LEDs that are mounted on the component side of the motherboard. Refer to Figures 2-1 and 2-2 for illustrations that shows the location of the component side LEDs. The following table lists all LEDs and states their function and location.

Table 2-2. 4221 Condor LEDs

Designator	Description	Location
LED 1	Board Status 0 (LSB)	Component Side
LED 2	Board Status 1	Component Side
LED 3	Board Status 2	Component Side
LED 4	Board Status 3 (MSB)	Component Side
LED 5	Board OK (Red/Green) Green = Board OK	Component Side
LED 6	Fused +12 Volts Status (AUI only)	Component Side
LED 7	FEC1, Link OK Status (10BaseT only)	Component Side
LED 8	FEC0, Link OK Status (10BaseT only)	Component Side

Board Status LEDs

LEDs 1, 2, 3, and 4 are Board Status LEDs which provide the following functions:

- Power On Self Test (POST) Mode
- Monitor Mode
- Run Mode

POST Mode: This mode provides diagnostics for the CPU and Buffer. Refer to the following table for a list of diagnostics performed while in this mode:

Table 2-3. Board Status Diagnostics Used In POST Mode

Hex Code	Diagnostic	Definition	Type of Test
0x01	CPU Register Test	CPUFATAL	CPU Core Test
0x02	ROM Checksum	ROMFAIL	CPU Core Test
0x03	Walking 1's SRAM	STAT1FAIL	CPU Core Test
0x04	Walking 0's SRAM	STAT0FAIL	CPU Core Test
0x05	Decrementing Longwords	STATLFAIL	CPU Core Test
0x06	Word Access	STATWFAIL	CPU Core Test
0x07	Byte Access	STATBFAIL	CPU Core Test
0x08	Reserved	RESERVED	CPU Core Test
0x09	Walking 1's In Buffer	BUFFERFAIL1	Static Buffer Test
0x0A	Walking 0's In Buffer	BUFFERFAIL0	Static Buffer Test
0x0B	Decrementing Longwords	BUFFERFAIL	Static Buffer Test
0x0C	Walking 1's, 0's VME DMA	VMEFAIL	Control Register Access
0x0D	Motherboard FEC Tests	FEC0 & 1	Control Register Access
0x0E	Daughter Card FEC Tests	FEC2 & 3	Control Register Access

Monitor Mode: In this mode, LEDs will sequentially flicker when Serial Port A is active and the onboard monitor is controlling the Condor.

Run Mode: When in this mode, the Condor is accepting commands from the host. Refer to the following table for a list of LED definitions while in this mode:

Table 2-4. Run Mode LED Matrix

LED1	LED2	LED3	LED4	Function
ON	OFF	OFF	OFF	1-4 Commands On Board
ON	ON	OFF	OFF	5-16 Commands On Board
ON	ON	ON	OFF	17-64 Commands On Board
ON	ON	ON	ON	65 or More Commands On Board

Step 3. Set Onboard Motherboard Jumpers

Set all onboard jumpers so that the Condor is properly configured for operation within your system. The board layout as illustrated in figure 2-1 shows the location of the jumpers.

Motherboard Jumper Settings

The following are jumpers and the default settings used on the Condor motherboard. IN refers to the jumper being installed across the pins indicated, OUT indicates the jumper is removed.

CAUTION!

Jumpers J1 through J4, J6 through J8, J10 and J11 are used for manufacturing options. If populated, they are configured to factory default settings. These jumpers must not be altered.

J5 FLASH0



IN: FLASH logic enabled.

OUT: FLASH logic disabled.

J9 +12 VOLTS Flash Programming Protect:



IN: +12 Volt power connected to EPROM socket.
 OUT: +12 Volt power disconnected from EPROM socket.

J12 VME Bus Grant:

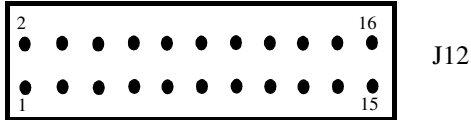

Pins 1 - 12 Reserved
 Pins 13 - 16 VME Bus Grant:

Table 2-5. VME Bus Grant Settings

BUS GRANT	PIN #	
	13-14	15-16
0	IN	IN
1	IN	OUT
2	OUT	IN
*3	*OUT	*OUT

* = Factory Default

J13 Firmware Option Jumpers:

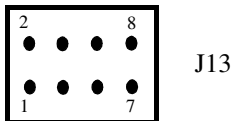

(Pins 1-2) Reserved
 (Pins 3-4) Memory Test Enable
 IN = Disable
 OUT = Enable

- (Pins 5-6) Console Message Disable
IN = Disable
OUT = Enable
- (Pins 7-8) GDB Enable Point
IN = GDB Initialized On Exit
OUT = GDB Initialized On Reset

J14 Firmware Option Jumpers:

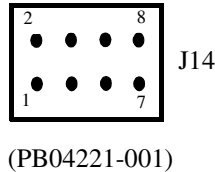
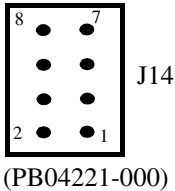

- (Pins 1-2) 16 Bit Block Enable (default = OUT)
IN = 16 bit Block Mode Disabled
OUT = 16 bit Block Mode Enabled
- (Pins 3-4) Sysfail (default = OUT)
IN = Clear Sysfail after passing diagnostics
OUT = Clear Sysfail before running Power-Up Diagnostics
- (Pins 5-6) Reserved
- (Pins 7-8) GDB Debugger Enable (default = OUT)
IN = Debugger Enabled
OUT = Debugger Disabled

J15 Firmware Option Jumpers / Secondary Short I/O Size:

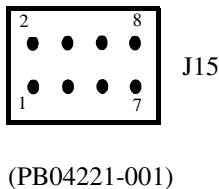
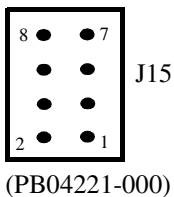

- (Pins 1-2) Load Firmware (default = OUT)
IN = Load firmware from on-board buffer
OUT = Load firmware from EPROM
- (Pins 3-4) On Board Monitor Enable (default = OUT)
IN = Stop in monitor after loading firmware
OUT = Normal Run Mode

Table 2-6. Secondary Short I/O

J15 PINS		SIZE (Bytes)
5-6	7-8	
OUT	OUT	256 bytes of Secondary Short I/O space
OUT	IN	512 bytes of Secondary Short I/O space
IN	OUT	1K bytes of Secondary Short I/O space
*IN	*IN	2K bytes of Secondary Short I/O space*

* Factory Default

J16 Primary Short I/O Size / Reset Enable:

Table 2-7. Primary Short I/O Size

J16 PINS		SIZE (Bytes)
1-2	3-4	
OUT	OUT	256 bytes of Primary Short I/O space
OUT	IN	512 bytes of Primary Short I/O space
IN	OUT	1K bytes of Primary Short I/O space
*IN	*IN	2K bytes of Primary Short I/O space*

* Factory Default

(Pins 5-6) Secondary Master Control Register (MCR) Reset Enable (default = OUT)

IN = Reset Enable

OUT = Reset Disable

(Pins 7-8) Primary Master Control Register (MCR) Reset Enable (default = IN)

IN = Reset Enabled

OUT = Reset Disabled

J17 Secondary Channel Address Modifiers:

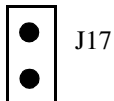

IN = Secondary Channel Address Modifiers 29 or 2D.

OUT = Secondary Channel Address Modifier 2D only.

J18 Primary Channel Address Modifiers:

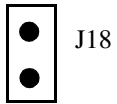

IN = Primary Channel Address Modifiers 29 or 2D

OUT = Primary Channel Address Modifier 2D only

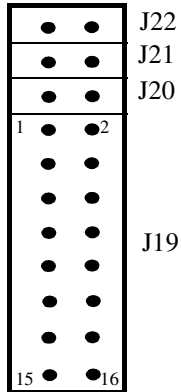
J19, J20, J21 & J22 Primary Short I/O Base Address:

Refer to the following tables when setting Primary Short I/O Base Addresses for the following:

- Primary Short I/O For 2K Base Address
- Primary Short I/O For 1K Base Address
- Primary Short I/O For 512 Bytes Base Address
- Primary Short I/O For 256 Bytes Base Address

NOTE:

The normal 4221 configuration is with the Primary Short I/O space disabled. To disable the Primary Short I/O, set pins 15-16 of Jumper J19 to 0 (IN), and all other pins to F (OUT).

Table 2-8. Primary Base Address For 2K Short I/O

ADDRESS	J19 PIN SETTINGS								J20, J21, J22 PIN SETTINGS		
	15-16	13-14	11-12	9-10	7-8	5-6	3-4	1-2	J20	J21	J22
0000	F	F	F	0	0	0	0	0	F	F	F
0800	F	F	F	F	0	0	0	0	F	F	F
1000	F	F	F	0	F	0	0	0	F	F	F
1800	F	F	F	F	F	0	0	0	F	F	F
2000	F	F	F	0	0	F	0	0	F	F	F
2800	F	F	F	F	0	F	0	0	F	F	F
3000	F	F	F	0	F	F	0	0	F	F	F
3800	F	F	F	F	F	F	0	0	F	F	F
4000	F	F	F	0	0	0	F	0	F	F	F
4800	F	F	F	F	0	0	F	0	F	F	F
5000	F	F	F	0	F	0	F	0	F	F	F
5800	F	F	F	F	F	0	F	0	F	F	F
6000	F	F	F	0	0	F	F	0	F	F	F
6800	F	F	F	F	0	F	F	0	F	F	F
7000	F	F	F	0	F	F	F	0	F	F	F
7800	F	F	F	F	F	F	F	0	F	F	F
8000	F	F	F	0	0	0	0	F	F	F	F
8800	F	F	F	F	0	0	0	F	F	F	F
9000	F	F	F	0	F	0	0	F	F	F	F
9800	F	F	F	F	F	0	0	F	F	F	F
A000	F	F	F	0	0	F	0	F	F	F	F
A800	F	F	F	F	0	F	0	F	F	F	F
B000	F	F	F	0	F	F	0	F	F	F	F
B800	F	F	F	F	F	F	0	F	F	F	F
C000	F	F	F	0	0	0	F	F	F	F	F
C800	F	F	F	F	0	0	F	F	F	F	F
D000	F	F	F	0	F	0	F	F	F	F	F
D800	F	F	F	F	F	0	F	F	F	F	F
E000	F	F	F	0	0	F	F	F	F	F	F
E800	F	F	F	F	0	F	F	F	F	F	F
F000	F	F	F	0	F	F	F	F	F	F	F
F800	F	F	F	F	F	F	F	F	F	F	F

NOTE: 0 = IN (Logical 0), F = OUT (Logical 1)

Table 2-9. Primary Base Address For 1K Short I/O

ADDRESS	J19 PIN SETTINGS								J20, J21, J22 PIN SETTINGS		
	15-16	13-14	11-12	9-10	7-8	5-6	3-4	1-2	J20	J21	J22
8000	F	F	0	0	0	0	0	F	F	F	0
8400	F	F	F	0	0	0	0	F	F	F	0
8800	F	F	0	F	0	0	0	F	F	F	0
8C00	F	F	F	F	0	0	0	F	F	F	0
9000	F	F	0	0	F	0	0	F	F	F	0
9400	F	F	F	0	F	0	0	F	F	F	0
9800	F	F	0	F	F	0	0	F	F	F	0
9C00	F	F	F	F	F	0	0	F	F	F	0
A000	F	F	0	0	0	F	0	F	F	F	0
A400	F	F	F	0	0	F	0	F	F	F	0
A800	F	F	0	F	0	F	0	F	F	F	0
AC00	F	F	F	F	0	F	0	F	F	F	0
B000	F	F	0	0	F	F	0	F	F	F	0
B400	F	F	F	0	F	F	0	F	F	F	0
B800	F	F	0	F	F	F	0	F	F	F	0
BC00	F	F	F	F	F	F	0	F	F	F	0
C000	F	F	0	0	0	0	F	F	F	F	0
C400	F	F	F	0	0	0	F	F	F	F	0
C800	F	F	0	F	0	0	F	F	F	F	0
CC00	F	F	F	F	0	0	F	F	F	F	0
D000	F	F	0	0	F	0	F	F	F	F	0
D400	F	F	F	0	F	0	F	F	F	F	0
D800	F	F	0	F	F	0	F	F	F	F	0
DC00	F	F	F	F	F	0	F	F	F	F	0
E000	F	F	0	0	0	F	F	F	F	F	0
E400	F	F	F	0	0	F	F	F	F	F	0
E800	F	F	0	F	0	F	F	F	F	F	0
EC00	F	F	F	F	0	F	F	F	F	F	0
F000	F	F	0	0	F	F	F	F	F	F	0
F400	F	F	F	0	F	F	F	F	F	F	0
F800	F	F	0	F	F	F	F	F	F	F	0
FC00	F	F	F	F	F	F	F	F	F	F	0

NOTE: 0 = IN (Logical 0), F = OUT (Logical 1)

Table 2-10. Primary Base Address For 512 Byte Short I/O

ADDRESS	J19 PIN SETTINGS								J20, J21, J22 PIN SETTINGS		
	15-16	13-14	11-12	9-10	7-8	5-6	3-4	1-2	J20	J21	J22
C000	F	0	0	0	0	0	F	F	F	0	0
C200	F	F	0	0	0	0	F	F	F	0	0
C400	F	0	F	0	0	0	F	F	F	0	0
C600	F	F	F	0	0	0	F	F	F	0	0
C800	F	0	0	F	0	0	F	F	F	0	0
CA00	F	F	0	F	0	0	F	F	F	0	0
CC00	F	0	F	F	0	0	F	F	F	0	0
CE00	F	F	F	F	0	0	F	F	F	0	0
D000	F	0	0	0	F	0	F	F	F	0	0
D200	F	F	0	0	F	0	F	F	F	0	0
D400	F	0	F	0	F	0	F	F	F	0	0
D600	F	F	F	0	F	0	F	F	F	0	0
D800	F	0	0	F	F	0	F	F	F	0	0
DA00	F	F	0	F	F	0	F	F	F	0	0
DC00	F	0	F	F	F	0	F	F	F	0	0
DE00	F	F	F	F	F	0	F	F	F	0	0
E000	F	0	0	0	0	F	F	F	F	0	0
E200	F	F	0	0	0	F	F	F	F	0	0
E400	F	0	F	0	0	F	F	F	F	0	0
E600	F	F	F	0	0	F	F	F	F	0	0
E800	F	0	0	F	0	F	F	F	F	0	0
EA00	F	F	0	F	0	F	F	F	F	0	0
EC00	F	0	F	F	0	F	F	F	F	0	0
EE00	F	F	F	F	0	F	F	F	F	0	0
F000	F	0	0	0	F	F	F	F	F	0	0
F200	F	F	0	0	F	F	F	F	F	0	0
F400	F	0	F	0	F	F	F	F	F	0	0
F600	F	F	F	0	F	F	F	F	F	0	0
F800	F	0	0	F	F	F	F	F	F	0	0
FA00	F	F	0	F	F	F	F	F	F	0	0
FC00	F	0	F	F	F	F	F	F	F	0	0
FE00	F	F	F	F	F	F	F	F	F	0	0

NOTE: 0 = IN (Logical 0), F = OUT (Logical 1)

Table 2-10. Primary Base Address For 512 Byte Short I/O (Continued)

ADDRESS	J19 PIN SETTINGS								J20, J21, J22 PIN SETTINGS		
	15-16	13-14	11-12	9-10	7-8	5-6	3-4	1-2	J20	J21	J22
0000	F	0	0	0	0	0	0	0	F	0	0
0200	F	F	0	0	0	0	0	0	F	0	0
0400	F	0	F	0	0	0	0	0	F	0	0
0600	F	F	F	0	0	0	0	0	F	0	0
0800	F	0	0	F	0	0	0	0	F	0	0
0A00	F	F	0	F	0	0	0	0	F	0	0
0C00	F	0	F	F	0	0	0	0	F	0	0
0E00	F	F	F	F	0	0	0	0	F	0	0
1000	F	0	0	0	F	0	0	0	F	0	0
1200	F	F	0	0	F	0	0	0	F	0	0
1400	F	0	F	0	F	0	0	0	F	0	0
1600	F	F	F	0	F	0	0	0	F	0	0
1800	F	0	0	F	F	0	0	0	F	0	0
1A00	F	F	0	F	F	0	0	0	F	0	0
1C00	F	0	F	F	F	0	0	0	F	0	0
1E00	F	F	F	F	F	0	0	0	F	0	0
2000	F	0	0	0	0	F	0	0	F	0	0
2200	F	F	0	0	0	F	0	0	F	0	0
2400	F	0	F	0	0	F	0	0	F	0	0
2600	F	F	F	0	0	F	0	0	F	0	0
2800	F	0	0	F	0	F	0	0	F	0	0
2A00	F	F	0	F	0	F	0	0	F	0	0
2C00	F	0	F	F	0	F	0	0	F	0	0
2E00	F	F	F	F	0	F	0	0	F	0	0
3000	F	0	0	0	F	F	0	0	F	0	0
3200	F	F	0	0	F	F	0	0	F	0	0
3400	F	0	F	0	F	F	0	0	F	0	0
3600	F	F	F	0	F	F	0	0	F	0	0
3800	F	0	0	F	F	F	0	0	F	0	0
3A00	F	F	0	F	F	F	0	0	F	0	0
3C00	F	0	F	F	F	F	0	0	F	0	0
3E00	F	F	F	F	F	F	0	0	F	0	0

NOTE: 0 = IN (Logical 0), F = OUT (Logical 1)

Table 2-11. Primary Base Address For 256 Byte Short I/O

ADDRESS	J19 PIN SETTINGS								J20, J21, J22 PIN SETTINGS		
	15-16	13-14	11-12	9-10	7-8	5-6	3-4	1-2	J20	J21	J22
0000	0	0	0	0	0	0	0	0	0	0	0
0100	F	0	0	0	0	0	0	0	0	0	0
0200	0	F	0	0	0	0	0	0	0	0	0
0300	F	F	0	0	0	0	0	0	0	0	0
0400	0	0	F	0	0	0	0	0	0	0	0
0500	F	0	F	0	0	0	0	0	0	0	0
0600	0	F	F	0	0	0	0	0	0	0	0
0700	F	F	F	0	0	0	0	0	0	0	0
0800	0	0	0	F	0	0	0	0	0	0	0
0900	F	0	0	F	0	0	0	0	0	0	0
0A00	0	F	0	F	0	0	0	0	0	0	0
0B00	F	F	0	F	0	0	0	0	0	0	0
0C00	0	0	F	F	0	0	0	0	0	0	0
0D00	F	0	F	F	0	0	0	0	0	0	0
0E00	0	F	F	F	0	0	0	0	0	0	0
0F00	F	F	F	F	0	0	0	0	0	0	0
1000	0	0	0	0	F	0	0	0	0	0	0
1100	F	0	0	0	F	0	0	0	0	0	0
1200	0	F	0	0	F	0	0	0	0	0	0
1300	F	F	0	0	F	0	0	0	0	0	0
1400	0	0	F	0	F	0	0	0	0	0	0
1500	F	0	F	0	F	0	0	0	0	0	0
1600	0	F	F	0	F	0	0	0	0	0	0
1700	F	F	F	0	F	0	0	0	0	0	0
1800	0	0	0	F	F	0	0	0	0	0	0
1900	F	0	0	F	F	0	0	0	0	0	0
1A00	0	F	0	F	F	0	0	0	0	0	0
1B00	F	F	0	F	F	0	0	0	0	0	0
1C00	0	0	F	F	F	0	0	0	0	0	0
1D00	F	0	F	F	F	0	0	0	0	0	0
1E00	0	F	F	F	F	0	0	0	0	0	0
1F00	F	F	F	F	F	0	0	0	0	0	0
2000	0	0	0	0	0	F	0	0	0	0	0
2100	F	0	0	0	0	F	0	0	0	0	0
2200	0	F	0	0	0	F	0	0	0	0	0
2300	F	F	0	0	0	F	0	0	0	0	0
2400	0	0	F	0	0	F	0	0	0	0	0
2500	F	0	F	0	0	F	0	0	0	0	0
2600	0	F	F	0	0	F	0	0	0	0	0
2700	F	F	F	0	0	F	0	0	0	0	0

NOTE: 0 = IN (Logical 0), F = OUT (Logical 1)

Table 2-11. Primary Base Address For 256 Byte Short I/O (Continued)

ADDRESS	J19 PIN SETTINGS								J20, J21, J22 PIN SETTINGS		
	15-16	13-14	11-12	9-10	7-8	5-6	3-4	1-2	J13	J14	J15
2800	0	0	0	F	0	F	0	0	0	0	0
2900	F	0	0	F	0	F	0	0	0	0	0
2A00	0	F	0	F	0	F	0	0	0	0	0
2B00	F	F	0	F	0	F	0	0	0	0	0
2C00	0	0	F	F	0	F	0	0	0	0	0
2D00	F	0	F	F	0	F	0	0	0	0	0
2E00	0	F	F	F	0	F	0	0	0	0	0
2F00	F	F	F	F	0	F	0	0	0	0	0
3000	0	0	0	0	F	F	0	0	0	0	0
3100	F	0	0	0	F	F	0	0	0	0	0
3200	0	F	0	0	F	F	0	0	0	0	0
3300	F	F	0	0	F	F	0	0	0	0	0
3400	0	0	F	0	F	F	0	0	0	0	0
3500	F	0	F	0	F	F	0	0	0	0	0
3600	0	F	F	0	F	F	0	0	0	0	0
3700	F	F	F	0	F	F	0	0	0	0	0
3800	0	0	0	F	F	F	0	0	0	0	0
3900	F	0	0	F	F	F	0	0	0	0	0
3A00	0	F	0	F	F	F	0	0	0	0	0
3B00	F	F	0	F	F	F	0	0	0	0	0
3C00	0	0	F	F	F	F	0	0	0	0	0
3D00	F	0	F	F	F	F	0	0	0	0	0
3E00	0	F	F	F	F	F	0	0	0	0	0
3F00	F	F	F	F	F	F	0	0	0	0	0
4000	0	0	0	0	0	0	F	0	0	0	0
4100	F	0	0	0	0	0	F	0	0	0	0
4200	0	F	0	0	0	0	F	0	0	0	0
4300	F	F	0	0	0	0	F	0	0	0	0
4400	0	0	F	0	0	0	F	0	0	0	0
4500	F	0	F	0	0	0	F	0	0	0	0
4600	0	F	F	0	0	0	F	0	0	0	0
4700	F	F	F	0	0	0	F	0	0	0	0
4800	0	0	0	F	0	0	F	0	0	0	0
4900	F	0	0	F	0	0	F	0	0	0	0
4A00	0	F	0	F	0	0	F	0	0	0	0
4B00	F	F	0	F	0	0	F	0	0	0	0
4C00	0	0	F	F	0	0	F	0	0	0	0
4D00	F	0	F	F	0	0	F	0	0	0	0
4E00	0	F	F	F	0	0	F	0	0	0	0
4F00	F	F	F	F	0	0	F	0	0	0	0

NOTE: 0 = IN (Logical 0), F = OUT (Logical 1)

Table 2-11. Primary Base Address For 256 Byte Short I/O (Continued)

ADDRESS	J19 PIN SETTINGS								J20, J21, J22 PIN SETTINGS		
	15-16	13-14	11-12	9-10	7-8	5-6	3-4	1-2	J20	J21	J22
5000	0	0	0	0	F	0	F	0	0	0	0
5100	F	0	0	0	F	0	F	0	0	0	0
5200	0	F	0	0	F	0	F	0	0	0	0
5300	F	F	0	0	F	0	F	0	0	0	0
5400	0	0	F	0	F	0	F	0	0	0	0
5500	F	0	F	0	F	0	F	0	0	0	0
5600	0	F	F	0	F	0	F	0	0	0	0
5700	F	F	F	0	F	0	F	0	0	0	0
5800	0	0	0	F	F	0	F	0	0	0	0
5900	F	0	0	F	F	0	F	0	0	0	0
5A00	0	F	0	F	F	0	F	0	0	0	0
5B00	F	F	0	F	F	0	F	0	0	0	0
5C00	0	0	F	F	F	0	F	0	0	0	0
5D00	F	0	F	F	F	0	F	0	0	0	0
5E00	0	F	F	F	F	0	F	0	0	0	0
5F00	F	F	F	F	F	0	F	0	0	0	0
6000	0	0	0	0	0	F	F	0	0	0	0
6100	F	0	0	0	0	F	F	0	0	0	0
6200	0	F	0	0	0	F	F	0	0	0	0
6300	F	F	0	0	0	F	F	0	0	0	0
6400	0	0	F	0	0	F	F	0	0	0	0
6500	F	0	F	0	0	F	F	0	0	0	0
6600	0	F	F	0	0	F	F	0	0	0	0
6700	F	F	F	0	0	F	F	0	0	0	0
6800	0	0	0	F	0	F	F	0	0	0	0
6900	F	0	0	F	0	F	F	0	0	0	0
6A00	0	F	0	F	0	F	F	0	0	0	0
6B00	F	F	0	F	0	F	F	0	0	0	0
6C00	0	0	F	F	0	F	F	0	0	0	0
6D00	F	0	F	F	0	F	F	0	0	0	0
6E00	0	F	F	F	0	F	F	0	0	0	0
6F00	F	F	F	F	0	F	F	0	0	0	0
7000	0	0	0	0	F	F	F	0	0	0	0
7100	F	0	0	0	F	F	F	0	0	0	0
7200	0	F	0	0	F	F	F	0	0	0	0
7300	F	F	0	0	F	F	F	0	0	0	0
7400	0	0	F	0	F	F	F	0	0	0	0
7500	F	0	F	0	F	F	F	0	0	0	0
7600	0	F	F	0	F	F	F	0	0	0	0
7700	F	F	F	0	F	F	F	0	0	0	0

NOTE: 0 = IN (Logical 0), F = OUT (Logical 1)

Table 2-11. Primary Base Address For 256 Byte Short I/O (Continued)

ADDRESS	J19 PIN SETTINGS								J20, J21, J22 PIN SETTINGS		
	15-16	13-14	11-12	9-10	7-8	5-6	3-4	1-2	J20	J21	J22
7800	0	0	0	F	F	F	F	0	0	0	0
7900	F	0	0	F	F	F	F	0	0	0	0
7A00	0	F	0	F	F	F	F	0	0	0	0
7B00	F	F	0	F	F	F	F	0	0	0	0
7C00	0	0	F	F	F	F	F	0	0	0	0
7D00	F	0	F	F	F	F	F	0	0	0	0
7E00	0	F	F	F	F	F	F	0	0	0	0
7F00	F	F	F	F	F	F	F	0	0	0	0
8000	0	0	0	0	0	0	0	F	0	0	0
8100	F	0	0	0	0	0	0	F	0	0	0
8200	0	F	0	0	0	0	0	F	0	0	0
8300	F	F	0	0	0	0	0	F	0	0	0
8400	0	0	F	0	0	0	0	F	0	0	0
8500	F	0	F	0	0	0	0	F	0	0	0
8600	0	F	F	0	0	0	0	F	0	0	0
8700	F	F	F	0	0	0	0	F	0	0	0
8800	0	0	0	F	0	0	0	F	0	0	0
8900	F	0	0	F	0	0	0	F	0	0	0
8A00	0	F	0	F	0	0	0	F	0	0	0
8B00	F	F	0	F	0	0	0	F	0	0	0
8C00	0	0	F	F	0	0	0	F	0	0	0
8D00	F	0	F	F	0	0	0	F	0	0	0
8E00	0	F	F	F	0	0	0	F	0	0	0
8F00	F	F	F	F	0	0	0	F	0	0	0
9000	0	0	0	0	F	0	0	F	0	0	0
9100	F	0	0	0	F	0	0	F	0	0	0
9200	0	F	0	0	F	0	0	F	0	0	0
9300	F	F	0	0	F	0	0	F	0	0	0
9400	0	0	F	0	F	0	0	F	0	0	0
9500	F	0	F	0	F	0	0	F	0	0	0
9600	0	F	F	0	F	0	0	F	0	0	0
9700	F	F	F	0	F	0	0	F	0	0	0
9800	0	0	0	F	F	0	0	F	0	0	0
9900	F	0	0	F	F	0	0	F	0	0	0
9A00	0	F	0	F	F	0	0	F	0	0	0
9B00	F	F	0	F	F	0	0	F	0	0	0
9C00	0	0	F	F	F	0	0	F	0	0	0
9D00	F	0	F	F	F	0	0	F	0	0	0
9E00	0	F	F	F	F	0	0	F	0	0	0
9F00	F	F	F	F	F	0	0	F	0	0	0

NOTE: 0 = IN (Logical 0), F = OUT (Logical 1)

Table 2-11. Primary Base Address For 256 Byte Short I/O (Continued)

ADDRESS	J19 PIN SETTINGS								J20, J21, J22 PIN SETTINGS		
	15-16	13-14	11-12	9-10	7-8	5-6	3-4	1-2	J20	J21	J22
A000	0	0	0	0	0	F	0	F	0	0	0
A100	F	0	0	0	0	F	0	F	0	0	0
A200	0	F	0	0	0	F	0	F	0	0	0
A300	F	F	0	0	0	F	0	F	0	0	0
A400	0	0	F	0	0	F	0	F	0	0	0
A500	F	0	F	0	0	F	0	F	0	0	0
A600	0	F	F	0	0	F	0	F	0	0	0
A700	F	F	F	0	0	F	0	F	0	0	0
A800	0	0	0	F	0	F	0	F	0	0	0
A900	F	0	0	F	0	F	0	F	0	0	0
AA00	0	F	0	F	0	F	0	F	0	0	0
AB00	F	F	0	F	0	F	0	F	0	0	0
AC00	0	0	F	F	0	F	0	F	0	0	0
AD00	F	0	F	F	0	F	0	F	0	0	0
AE00	0	F	F	F	0	F	0	F	0	0	0
AF00	F	F	F	F	0	F	0	F	0	0	0
B000	0	0	0	0	F	F	0	F	0	0	0
B100	F	0	0	0	F	F	0	F	0	0	0
B200	0	F	0	0	F	F	0	F	0	0	0
B300	F	F	0	0	F	F	0	F	0	0	0
B400	0	0	F	0	F	F	0	F	0	0	0
B500	F	0	F	0	F	F	0	F	0	0	0
B600	0	F	F	0	F	F	0	F	0	0	0
B700	F	F	F	0	F	F	0	F	0	0	0
B800	0	0	0	F	F	F	0	F	0	0	0
B900	F	0	0	F	F	F	0	F	0	0	0
BA00	0	F	0	F	F	F	0	F	0	0	0
BB00	F	F	0	F	F	F	0	F	0	0	0
BC00	0	0	F	F	F	F	0	F	0	0	0
BD00	F	0	F	F	F	F	0	F	0	0	0
BE00	0	F	F	F	F	F	0	F	0	0	0
BF00	F	F	F	F	F	F	0	F	0	0	0
C000	0	0	0	0	0	0	F	F	0	0	0
C100	F	0	0	0	0	0	F	F	0	0	0
C200	0	F	0	0	0	0	F	F	0	0	0
C300	F	F	0	0	0	0	F	F	0	0	0
C400	0	0	F	0	0	0	F	F	0	0	0
C500	F	0	F	0	0	0	F	F	0	0	0
C600	0	F	F	0	0	0	F	F	0	0	0
C700	F	F	F	0	0	0	F	F	0	0	0

NOTE: 0 = IN (Logical 0), F = OUT (Logical 1)

Table 2-11. Primary Base Address For 256 Byte Short I/O (Continued)

ADDRESS	J19 PIN SETTINGS								J20, J21, J22 PIN SETTINGS		
	15-16	13-14	11-12	9-10	7-8	5-6	3-4	1-2	J20	J21	J22
C800	0	0	0	F	0	0	F	F	0	0	0
C900	F	0	0	F	0	0	F	F	0	0	0
CA00	0	F	0	F	0	0	F	F	0	0	0
CB00	F	F	0	F	0	0	F	F	0	0	0
CC00	0	0	F	F	0	0	F	F	0	0	0
CD00	F	0	F	F	0	0	F	F	0	0	0
CE00	0	F	F	F	0	0	F	F	0	0	0
CF00	F	F	F	F	0	0	F	F	0	0	0
D000	0	0	0	0	F	0	F	F	0	0	0
D100	F	0	0	0	F	0	F	F	0	0	0
D200	0	F	0	0	F	0	F	F	0	0	0
D300	F	F	0	0	F	0	F	F	0	0	0
D400	0	0	F	0	F	0	F	F	0	0	0
D500	F	0	F	0	F	0	F	F	0	0	0
D600	0	F	F	0	F	0	F	F	0	0	0
D700	F	F	F	0	F	0	F	F	0	0	0
D800	0	0	0	F	F	0	F	F	0	0	0
D900	F	0	0	F	F	0	F	F	0	0	0
DA00	0	F	0	F	F	0	F	F	0	0	0
DB00	F	F	0	F	F	0	F	F	0	0	0
DC00	0	0	F	F	F	0	F	F	0	0	0
DD00	F	0	F	F	F	0	F	F	0	0	0
DE00	0	F	F	F	F	0	F	F	0	0	0
DF00	F	F	F	F	F	0	F	F	0	0	0
E000	0	0	0	0	0	F	F	F	0	0	0
E100	F	0	0	0	0	F	F	F	0	0	0
E200	0	F	0	0	0	F	F	F	0	0	0
E300	F	F	0	0	0	F	F	F	0	0	0
E400	0	0	F	0	0	F	F	F	0	0	0
E500	F	0	F	0	0	F	F	F	0	0	0
E600	0	F	F	0	0	F	F	F	0	0	0
E700	F	F	F	0	0	F	F	F	0	0	0
E800	0	0	0	F	0	F	F	F	0	0	0
E900	F	0	0	F	0	F	F	F	0	0	0
EA00	0	F	0	F	0	F	F	F	0	0	0
EB00	F	F	0	F	0	F	F	F	0	0	0
EC00	0	0	F	F	0	F	F	F	0	0	0
ED00	F	0	F	F	0	F	F	F	0	0	0
EE00	0	F	F	F	0	F	F	F	0	0	0
EF00	F	F	F	F	0	F	F	F	0	0	0

NOTE: 0 = IN (Logical 0), F = OUT (Logical 1)

Table 2-11. Primary Base Address For 256 Byte Short I/O (Continued)

ADDRESS	J19 PIN SETTINGS								J20, J21, J22 PIN SETTINGS		
	15-16	13-14	11-12	9-10	7-8	5-6	3-4	1-2	J20	J21	J22
F000	0	0	0	0	F	F	F	F	0	0	0
F100	F	0	0	0	F	F	F	F	0	0	0
F200	0	F	0	0	F	F	F	F	0	0	0
F300	F	F	0	0	F	F	F	F	0	0	0
F400	0	0	F	0	F	F	F	F	0	0	0
F500	F	0	F	0	F	F	F	F	0	0	0
F600	0	F	F	0	F	F	F	F	0	0	0
F700	F	F	F	0	F	F	F	F	0	0	0
F800	0	0	0	F	F	F	F	F	0	0	0
F900	F	0	0	F	F	F	F	F	0	0	0
FA00	0	F	0	F	F	F	F	F	0	0	0
FB00	F	F	0	F	F	F	F	F	0	0	0
FC00	0	0	F	F	F	F	F	F	0	0	0
FD00	F	0	F	F	F	F	F	F	0	0	0
FE00	0	F	F	F	F	F	F	F	0	0	0
FF00	F	F	F	F	F	F	F	F	0	0	0

NOTE: 0 = IN (Logical 0), F = OUT (Logical 1)

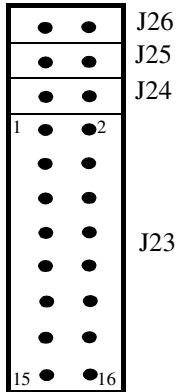
J23, J24, J25 & J26 Secondary Short I/O Address:

Refer to the following tables when setting Secondary Short I/O Base Addresses for the following:

- Secondary Short I/O For 2K Base Address
- Secondary Short I/O For 1K Base Address
- Secondary Short I/O For 512 Bytes Base Address
- Secondary Short I/O For 256 Bytes Base Address

NOTE:

The short I/O interface of the 4221 Condor is accessed through the Secondary Short I/O space only. The normal configuration is for the Secondary Short I/O to be enabled. To disable the Secondary Short I/O, set pins 15-16 of Jumper J23 to 0 (IN), and all other pins to F (OUT).

Table 2-12. Secondary Base Address For 2K Short I/O

ADDRESS	J23 PIN SETTINGS								J24, J25, J26 PIN SETTINGS		
	15-16	13-14	11-12	9-10	7-8	5-6	3-4	1-2	J24	J25	J26
0000	F	F	F	0	0	0	0	0	F	F	F
0800	F	F	F	F	0	0	0	0	F	F	F
1000	F	F	F	0	F	0	0	0	F	F	F
1800	F	F	F	F	F	0	0	0	F	F	F
2000	F	F	F	0	0	F	0	0	F	F	F
2800	F	F	F	F	0	F	0	0	F	F	F
3000	F	F	F	0	F	F	0	0	F	F	F
3800	F	F	F	F	F	F	0	0	F	F	F
4000	F	F	F	0	0	0	F	0	F	F	F
4800	F	F	F	F	0	0	F	0	F	F	F
5000	F	F	F	0	F	0	F	0	F	F	F
5800	F	F	F	F	F	0	F	0	F	F	F
6000	F	F	F	0	0	F	F	0	F	F	F
6800	F	F	F	F	0	F	F	0	F	F	F
7000	F	F	F	0	F	F	F	0	F	F	F
7800	F	F	F	F	F	F	F	0	F	F	F
8000	F	F	F	0	0	0	0	F	F	F	F
8800	F	F	F	F	0	0	0	F	F	F	F
9000	F	F	F	0	F	0	0	F	F	F	F
9800	F	F	F	F	F	0	0	F	F	F	F
A000	F	F	F	0	0	F	0	F	F	F	F
A800	F	F	F	F	0	F	0	F	F	F	F
B000	F	F	F	0	F	F	0	F	F	F	F
B800	F	F	F	F	F	F	0	F	F	F	F
C000	F	F	F	0	0	0	F	F	F	F	F
C800	F	F	F	F	0	0	F	F	F	F	F
D000	F	F	F	0	F	0	F	F	F	F	F
D800	F	F	F	F	F	0	F	F	F	F	F
E000	F	F	F	0	0	F	F	F	F	F	F
E800	F	F	F	F	0	F	F	F	F	F	F
F000	F	F	F	0	F	F	F	F	F	F	F
F800	F	F	F	F	F	F	F	F	F	F	F

NOTE: 0 = IN (Logical 0), F = OUT (Logical 1)

Table 2-13. Secondary Base Address For 1K Short I/O

ADDRESS	J23 PIN SETTINGS								J24, J25, J26 PIN SETTINGS		
	15-16	13-14	11-12	9-10	7-8	5-6	3-4	1-2	J24	J25	J26
0000	F	F	0	0	0	0	0	0	F	F	0
0400	F	F	F	0	0	0	0	0	F	F	0
0800	F	F	0	F	0	0	0	0	F	F	0
0C00	F	F	F	F	0	0	0	0	F	F	0
1000	F	F	0	0	F	0	0	0	F	F	0
1400	F	F	F	0	F	0	0	0	F	F	0
1800	F	F	0	F	F	0	0	0	F	F	0
1C00	F	F	F	F	F	0	0	0	F	F	0
2000	F	F	0	0	0	F	0	0	F	F	0
2400	F	F	F	0	0	F	0	0	F	F	0
2800	F	F	0	F	0	F	0	0	F	F	0
2C00	F	F	F	F	0	F	0	0	F	F	0
3000	F	F	0	0	F	F	0	0	F	F	0
3400	F	F	F	0	F	F	0	0	F	F	0
3800	F	F	0	F	F	F	0	0	F	F	0
3C00	F	F	F	F	F	F	0	0	F	F	0
4000	F	F	0	0	0	0	F	0	F	F	0
4400	F	F	F	0	0	0	F	0	F	F	0
4800	F	F	0	F	0	0	F	0	F	F	0
4C00	F	F	F	F	0	0	F	0	F	F	0
5000	F	F	0	0	F	0	F	0	F	F	0
5400	F	F	F	0	F	0	F	0	F	F	0
5800	F	F	0	F	F	0	F	0	F	F	0
5C00	F	F	F	F	F	0	F	0	F	F	0
6000	F	F	0	0	0	F	F	0	F	F	0
6400	F	F	F	0	0	F	F	0	F	F	0
6800	F	F	0	F	0	F	F	0	F	F	0
6C00	F	F	F	F	0	F	F	0	F	F	0
7000	F	F	0	0	F	F	F	0	F	F	0
7400	F	F	F	0	F	F	F	0	F	F	0
7800	F	F	0	F	F	F	F	0	F	F	0
7C00	F	F	F	F	F	F	F	0	F	F	0

NOTE: 0 = IN (Logical 0), F = OUT (Logical 1)

Table 2-13. Secondary Base Address For 1K Short I/O (Continued)

ADDRESS	J23 PIN SETTINGS								J24, J25, J26 PIN SETTINGS		
	15-16	13-14	11-12	9-10	7-8	5-6	3-4	1-2	J24	J25	J26
8000	F	F	0	0	0	0	0	F	F	F	0
8400	F	F	F	0	0	0	0	F	F	F	0
8800	F	F	0	F	0	0	0	F	F	F	0
8C00	F	F	F	F	0	0	0	F	F	F	0
9000	F	F	0	0	F	0	0	F	F	F	0
9400	F	F	F	0	F	0	0	F	F	F	0
9800	F	F	0	F	F	0	0	F	F	F	0
9C00	F	F	F	F	F	0	0	F	F	F	0
A000	F	F	0	0	0	F	0	F	F	F	0
A400	F	F	F	0	0	F	0	F	F	F	0
A800	F	F	0	F	0	F	0	F	F	F	0
AC00	F	F	F	F	0	F	0	F	F	F	0
B000	F	F	0	0	F	F	0	F	F	F	0
B400	F	F	F	0	F	F	0	F	F	F	0
B800	F	F	0	F	F	F	0	F	F	F	0
BC00	F	F	F	F	F	F	0	F	F	F	0
C000	F	F	0	0	0	0	F	F	F	F	0
C400	F	F	F	0	0	0	F	F	F	F	0
C800	F	F	0	F	0	0	F	F	F	F	0
CC00	F	F	F	F	0	0	F	F	F	F	0
D000	F	F	0	0	F	0	F	F	F	F	0
D400	F	F	F	0	F	0	F	F	F	F	0
D800	F	F	0	F	F	0	F	F	F	F	0
DC00	F	F	F	F	F	0	F	F	F	F	0
E000	F	F	0	0	0	F	F	F	F	F	0
E400	F	F	F	0	0	F	F	F	F	F	0
E800	F	F	0	F	0	F	F	F	F	F	0
EC00	F	F	F	F	0	F	F	F	F	F	0
F000	F	F	0	0	F	F	F	F	F	F	0
F400	F	F	F	0	F	F	F	F	F	F	0
F800	F	F	0	F	F	F	F	F	F	F	0
FC00	F	F	F	F	F	F	F	F	F	F	0

NOTE: 0 = IN (Logical 0), F = OUT (Logical 1)

Table 2-14. Secondary Base Address For 512 Byte Short I/O

ADDRESS	J23 PIN SETTINGS								J24, J25, J26 PIN SETTINGS		
	15-16	13-14	11-12	9-10	7-8	5-6	3-4	1-2	J24	J25	J26
0000	F	0	0	0	0	0	0	0	F	0	0
0200	F	F	0	0	0	0	0	0	F	0	0
0400	F	0	F	0	0	0	0	0	F	0	0
0600	F	F	F	0	0	0	0	0	F	0	0
0800	F	0	0	F	0	0	0	0	F	0	0
0A00	F	F	0	F	0	0	0	0	F	0	0
0C00	F	0	F	F	0	0	0	0	F	0	0
0E00	F	F	F	F	0	0	0	0	F	0	0
1000	F	0	0	0	F	0	0	0	F	0	0
1200	F	F	0	0	F	0	0	0	F	0	0
1400	F	0	F	0	F	0	0	0	F	0	0
1600	F	F	F	0	F	0	0	0	F	0	0
1800	F	0	0	F	F	0	0	0	F	0	0
1A00	F	F	0	F	F	0	0	0	F	0	0
1C00	F	0	F	F	F	0	0	0	F	0	0
1E00	F	F	F	F	F	0	0	0	F	0	0
2000	F	0	0	0	0	F	0	0	F	0	0
2200	F	F	0	0	0	F	0	0	F	0	0
2400	F	0	F	0	0	F	0	0	F	0	0
2600	F	F	F	0	0	F	0	0	F	0	0
2800	F	0	0	F	0	F	0	0	F	0	0
2A00	F	F	0	F	0	F	0	0	F	0	0
2C00	F	0	F	F	0	F	0	0	F	0	0
2E00	F	F	F	F	0	F	0	0	F	0	0
3000	F	0	0	0	F	F	0	0	F	0	0
3200	F	F	0	0	F	F	0	0	F	0	0
3400	F	0	F	0	F	F	0	0	F	0	0
3600	F	F	F	0	F	F	0	0	F	0	0
3800	F	0	0	F	F	F	0	0	F	0	0
3A00	F	F	0	F	F	F	0	0	F	0	0
3C00	F	0	F	F	F	F	0	0	F	0	0
3E00	F	F	F	F	F	F	0	0	F	0	0
4000	F	0	0	0	0	0	F	0	F	0	0
4200	F	F	0	0	0	0	F	0	F	0	0
4400	F	0	F	0	0	0	F	0	F	0	0
4600	F	F	F	0	0	0	F	0	F	0	0
4800	F	0	0	F	0	0	F	0	F	0	0
4A00	F	F	0	F	0	0	F	0	F	0	0
4C00	F	0	F	F	0	0	F	0	F	0	0
4E00	F	F	F	F	0	0	F	0	F	0	0

NOTE: 0 = IN (Logical 0), F = OUT (Logical 1)

Table 2-14. Secondary Base Address For 512 Byte Short I/O (Continued)

ADDRESS	J23 PIN SETTINGS								J24,J25,J26 PIN SETTINGS		
	15-16	13-14	11-12	9-10	7-8	5-6	3-4	1-2	J24	J25	J26
5000	F	0	0	0	F	0	F	0	F	0	0
5200	F	F	0	0	F	0	F	0	F	0	0
5400	F	0	F	0	F	0	F	0	F	0	0
5600	F	F	F	0	F	0	F	0	F	0	0
5800	F	0	0	F	F	0	F	0	F	0	0
5A00	F	F	0	F	F	0	F	0	F	0	0
5C00	F	0	F	F	F	0	F	0	F	0	0
5E00	F	F	F	F	F	0	F	0	F	0	0
6000	F	0	0	0	0	F	F	0	F	0	0
6200	F	F	0	0	0	F	F	0	F	0	0
6400	F	0	F	0	0	F	F	0	F	0	0
6600	F	F	F	0	0	F	F	0	F	0	0
6800	F	0	0	F	0	F	F	0	F	0	0
6A00	F	F	0	F	0	F	F	0	F	0	0
6C00	F	0	F	F	0	F	F	0	F	0	0
6E00	F	F	F	F	0	F	F	0	F	0	0
7000	F	0	0	0	F	F	F	0	F	0	0
7200	F	F	0	0	F	F	F	0	F	0	0
7400	F	0	F	0	F	F	F	0	F	0	0
7600	F	F	F	0	F	F	F	0	F	0	0
7800	F	0	0	F	F	F	F	0	F	0	0
7A00	F	F	0	F	F	F	F	0	F	0	0
7C00	F	0	F	F	F	F	F	0	F	0	0
7E00	F	F	F	F	F	F	F	0	F	0	0
8000	F	0	0	0	0	0	0	F	F	0	0
8200	F	F	0	0	0	0	0	F	F	0	0
8400	F	0	F	0	0	0	0	F	F	0	0
8600	F	F	F	0	0	0	0	F	F	0	0
8800	F	0	0	F	0	0	0	F	F	0	0
8A00	F	F	0	F	0	0	0	F	F	0	0
8C00	F	0	F	F	0	0	0	F	F	0	0
8E00	F	F	F	F	0	0	0	F	F	0	0
9000	F	0	0	0	F	0	0	F	F	0	0
9200	F	F	0	0	F	0	0	F	F	0	0
9400	F	0	F	0	F	0	0	F	F	0	0
9600	F	F	F	0	F	0	0	F	F	0	0
9800	F	0	0	F	F	0	0	F	F	0	0
9A00	F	F	0	F	F	0	0	F	F	0	0
9C00	F	0	F	F	F	0	0	F	F	0	0
9E00	F	F	F	F	F	0	0	F	F	0	0

NOTE: 0 = IN (Logical 0), F = OUT (Logical 1)

Table 2-14. Secondary Base Address For 512 Byte Short I/O (Continued)

ADDRESS	J23 PIN SETTINGS								J24, J25, J26 PIN SETTINGS		
	15-16	13-14	11-12	9-10	7-8	5-6	3-4	1-2	J24	J25	J26
A000	F	0	0	0	0	F	0	F	F	0	0
A200	F	F	0	0	0	F	0	F	F	0	0
A400	F	0	F	0	0	F	0	F	F	0	0
A600	F	F	F	0	0	F	0	F	F	0	0
A800	F	0	0	F	0	F	0	F	F	0	0
AA00	F	F	0	F	0	F	0	F	F	0	0
AC00	F	0	F	F	0	F	0	F	F	0	0
AE00	F	F	F	F	0	F	0	F	F	0	0
B000	F	0	0	0	F	F	0	F	F	0	0
B200	F	F	0	0	F	F	0	F	F	0	0
B400	F	0	F	0	F	F	0	F	F	0	0
B600	F	F	F	0	F	F	0	F	F	0	0
B800	F	0	0	F	F	F	0	F	F	0	0
BA00	F	F	0	F	F	F	0	F	F	0	0
BC00	F	0	F	F	F	F	0	F	F	0	0
BE00	F	F	F	F	F	F	0	F	F	0	0
C000	F	0	0	0	0	0	F	F	F	0	0
C200	F	F	0	0	0	0	F	F	F	0	0
C400	F	0	F	0	0	0	F	F	F	0	0
C600	F	F	F	0	0	0	F	F	F	0	0
C800	F	0	0	F	0	0	F	F	F	0	0
CA00	F	F	0	F	0	0	F	F	F	0	0
CC00	F	0	F	F	0	0	F	F	F	0	0
CE00	F	F	F	F	0	0	F	F	F	0	0
D000	F	0	0	0	F	0	F	F	F	0	0
D200	F	F	0	0	F	0	F	F	F	0	0
D400	F	0	F	0	F	0	F	F	F	0	0
D600	F	F	F	0	F	0	F	F	F	0	0
D800	F	0	0	F	F	0	F	F	F	0	0
DA00	F	F	0	F	F	0	F	F	F	0	0
DC00	F	0	F	F	F	0	F	F	F	0	0
DE00	F	F	F	F	F	0	F	F	F	0	0
E000	F	0	0	0	0	F	F	F	F	0	0
E200	F	F	0	0	0	F	F	F	F	0	0
E400	F	0	F	0	0	F	F	F	F	0	0
E600	F	F	F	0	0	F	F	F	F	0	0
E800	F	0	0	F	0	F	F	F	F	0	0
EA00	F	F	0	F	0	F	F	F	F	0	0
EC00	F	0	F	F	0	F	F	F	F	0	0
EE00	F	F	F	F	0	F	F	F	F	0	0

NOTE: 0 = IN (Logical 0), F= OUT (Logical 1)

Table 2-14. Secondary Base Address For 512 Byte Short I/O (Continued)

ADDRESS	J23 PIN SETTINGS								J24, J25, J26 PIN SETTINGS		
	15-16	13-14	11-12	9-10	7-8	5-6	3-4	1-2	J24	J25	J26
F000	F	0	0	0	F	F	F	F	F	0	0
F200	F	F	0	0	F	F	F	F	F	0	0
F400	F	0	F	0	F	F	F	F	F	0	0
F600	F	F	F	0	F	F	F	F	F	0	0
F800	F	0	0	F	F	F	F	F	F	0	0
FA00	F	F	0	F	F	F	F	F	F	0	0
FC00	F	0	F	F	F	F	F	F	F	0	0
FE00	F	F	F	F	F	F	F	F	F	0	0

Table 2-15. Secondary Base Address For 256 Byte Short I/O

ADDRESS	J23 PIN SETTINGS								J24, J25, J26 PIN SETTINGS		
	15-16	13-14	11-12	9-10	7-8	5-6	3-4	1-2	J24	J25	J26
0000	0	0	0	0	0	0	0	0	0	0	0
0100	F	0	0	0	0	0	0	0	0	0	0
0200	0	F	0	0	0	0	0	0	0	0	0
0300	F	F	0	0	0	0	0	0	0	0	0
0400	0	0	F	0	0	0	0	0	0	0	0
0500	F	0	F	0	0	0	0	0	0	0	0
0600	0	F	F	0	0	0	0	0	0	0	0
0700	F	F	F	0	0	0	0	0	0	0	0
0800	0	0	0	F	0	0	0	0	0	0	0
0900	F	0	0	F	0	0	0	0	0	0	0
0A00	0	F	0	F	0	0	0	0	0	0	0
0B00	F	F	0	F	0	0	0	0	0	0	0
0C00	0	0	F	F	0	0	0	0	0	0	0
0D00	F	0	F	F	0	0	0	0	0	0	0
0E00	0	F	F	F	0	0	0	0	0	0	0
0F00	F	F	F	F	0	0	0	0	0	0	0
1000	0	0	0	0	F	0	0	0	0	0	0
1100	F	0	0	0	F	0	0	0	0	0	0
1200	0	F	0	0	F	0	0	0	0	0	0
1300	F	F	0	0	F	0	0	0	0	0	0
1400	0	0	F	0	F	0	0	0	0	0	0
1500	F	0	F	0	F	0	0	0	0	0	0
1600	0	F	F	0	F	0	0	0	0	0	0
1700	F	F	F	0	F	0	0	0	0	0	0
1800	0	0	0	F	F	0	0	0	0	0	0
1900	F	0	0	F	F	0	0	0	0	0	0
1A00	0	F	0	F	F	0	0	0	0	0	0
1B00	F	F	0	F	F	0	0	0	0	0	0
1C00	0	0	F	F	F	0	0	0	0	0	0
1D00	F	0	F	F	F	0	0	0	0	0	0
1E00	0	F	F	F	F	0	0	0	0	0	0
1F00	F	F	F	F	F	0	0	0	0	0	0
2000	0	0	0	0	0	F	0	0	0	0	0
2100	F	0	0	0	0	F	0	0	0	0	0
2200	0	F	0	0	0	F	0	0	0	0	0
2300	F	F	0	0	0	F	0	0	0	0	0
2400	0	0	F	0	0	F	0	0	0	0	0
2500	F	0	F	0	0	F	0	0	0	0	0
2600	0	F	F	0	0	F	0	0	0	0	0
2700	F	F	F	0	0	F	0	0	0	0	0

NOTE: 0 = IN (Logical 0), F = OUT (Logical 1)

Table 2-15. Secondary Base Address For 256 Byte Short I/O (Continued)

ADDRESS	J23 PIN SETTINGS								J24, J25, J26 PIN SETTINGS		
	15-16	13-14	11-12	9-10	7-8	5-6	3-4	1-2	J24	J25	J26
2800	0	0	0	F	0	F	0	0	0	0	0
2900	F	0	0	F	0	F	0	0	0	0	0
2A00	0	F	0	F	0	F	0	0	0	0	0
2B00	F	F	0	F	0	F	0	0	0	0	0
2C00	0	0	F	F	0	F	0	0	0	0	0
2D00	F	0	F	F	0	F	0	0	0	0	0
2E00	0	F	F	F	0	F	0	0	0	0	0
2F00	F	F	F	F	0	F	0	0	0	0	0
3000	0	0	0	0	F	F	0	0	0	0	0
3100	F	0	0	0	F	F	0	0	0	0	0
3200	0	F	0	0	F	F	0	0	0	0	0
3300	F	F	0	0	F	F	0	0	0	0	0
3400	0	0	F	0	F	F	0	0	0	0	0
3500	F	0	F	0	F	F	0	0	0	0	0
3600	0	F	F	0	F	F	0	0	0	0	0
3700	F	F	F	0	F	F	0	0	0	0	0
3800	0	0	0	F	F	F	0	0	0	0	0
3900	F	0	0	F	F	F	0	0	0	0	0
3A00	0	F	0	F	F	F	0	0	0	0	0
3B00	F	F	0	F	F	F	0	0	0	0	0
3C00	0	0	F	F	F	F	0	0	0	0	0
3D00	F	0	F	F	F	F	0	0	0	0	0
3E00	0	F	F	F	F	F	0	0	0	0	0
3F00	F	F	F	F	F	F	0	0	0	0	0
4000	0	0	0	0	0	0	F	0	0	0	0
4100	F	0	0	0	0	0	F	0	0	0	0
4200	0	F	0	0	0	0	F	0	0	0	0
4300	F	F	0	0	0	0	F	0	0	0	0
4400	0	0	F	0	0	0	F	0	0	0	0
4500	F	0	F	0	0	0	F	0	0	0	0
4600	0	F	F	0	0	0	F	0	0	0	0
4700	F	F	F	0	0	0	F	0	0	0	0
4800	0	0	0	F	0	0	F	0	0	0	0
4900	F	0	0	F	0	0	F	0	0	0	0
4A00	0	F	0	F	0	0	F	0	0	0	0
4B00	F	F	0	F	0	0	F	0	0	0	0
4C00	0	0	F	F	0	0	F	0	0	0	0
4D00	F	0	F	F	0	0	F	0	0	0	0
4E00	0	F	F	F	0	0	F	0	0	0	0
4F00	F	F	F	F	0	0	F	0	0	0	0

NOTE: 0 = IN (Logical 0), F = OUT (Logical 1)

Table 2-15. Secondary Base Address For 256 Byte Short I/O (Continued)

ADDRESS	J23 PIN SETTINGS								J24, J25, J26 PIN SETTINGS		
	15-16	13-14	11-12	9-10	7-8	5-6	3-4	1-2	J24	J25	J26
5000	0	0	0	0	F	0	F	0	0	0	0
5100	F	0	0	0	F	0	F	0	0	0	0
5200	0	F	0	0	F	0	F	0	0	0	0
5300	F	F	0	0	F	0	F	0	0	0	0
5400	0	0	F	0	F	0	F	0	0	0	0
5500	F	0	F	0	F	0	F	0	0	0	0
5600	0	F	F	0	F	0	F	0	0	0	0
5700	F	F	F	0	F	0	F	0	0	0	0
5800	0	0	0	F	F	0	F	0	0	0	0
5900	F	0	0	F	F	0	F	0	0	0	0
5A00	0	F	0	F	F	0	F	0	0	0	0
5B00	F	F	0	F	F	0	F	0	0	0	0
5C00	0	0	F	F	F	0	F	0	0	0	0
5D00	F	0	F	F	F	0	F	0	0	0	0
5E00	0	F	F	F	F	0	F	0	0	0	0
5F00	F	F	F	F	F	0	F	0	0	0	0
6000	0	0	0	0	0	F	F	0	0	0	0
6100	F	0	0	0	0	F	F	0	0	0	0
6200	0	F	0	0	0	F	F	0	0	0	0
6300	F	F	0	0	0	F	F	0	0	0	0
6400	0	0	F	0	0	F	F	0	0	0	0
6500	F	0	F	0	0	F	F	0	0	0	0
6600	0	F	F	0	0	F	F	0	0	0	0
6700	F	F	F	0	0	F	F	0	0	0	0
6800	0	0	0	F	0	F	F	0	0	0	0
6900	F	0	0	F	0	F	F	0	0	0	0
6A00	0	F	0	F	0	F	F	0	0	0	0
6B00	F	F	0	F	0	F	F	0	0	0	0
6C00	0	0	F	F	0	F	F	0	0	0	0
6D00	F	0	F	F	0	F	F	0	0	0	0
6E00	0	F	F	F	0	F	F	0	0	0	0
6F00	F	F	F	F	0	F	F	0	0	0	0
7000	0	0	0	0	F	F	F	0	0	0	0
7100	F	0	0	0	F	F	F	0	0	0	0
7200	0	F	0	0	F	F	F	0	0	0	0
7300	F	F	0	0	F	F	F	0	0	0	0
7400	0	0	F	0	F	F	F	0	0	0	0
7500	F	0	F	0	F	F	F	0	0	0	0
7600	0	F	F	0	F	F	F	0	0	0	0
7700	F	F	F	0	F	F	F	0	0	0	0

NOTE: 0 = IN (Logical 0), F= OUT (Logical 1)

Table 2-15. Secondary Base Address For 256 Byte Short I/O (Continued)

ADDRESS	J23 PIN SETTINGS								J24, J25, J26 PIN SETTINGS		
	15-16	13-14	11-12	9-10	7-8	5-6	3-4	1-2	J24	J25	J26
7800	0	0	0	F	F	F	F	0	0	0	0
7900	F	0	0	F	F	F	F	0	0	0	0
7A00	0	F	0	F	F	F	F	0	0	0	0
7B00	F	F	0	F	F	F	F	0	0	0	0
7C00	0	0	F	F	F	F	F	0	0	0	0
7D00	F	0	F	F	F	F	F	0	0	0	0
7E00	0	F	F	F	F	F	F	0	0	0	0
7F00	F	F	F	F	F	F	F	0	0	0	0
8000	0	0	0	0	0	0	0	F	0	0	0
8100	F	0	0	0	0	0	0	F	0	0	0
8200	0	F	0	0	0	0	0	F	0	0	0
8300	F	F	0	0	0	0	0	F	0	0	0
8400	0	0	F	0	0	0	0	F	0	0	0
8500	F	0	F	0	0	0	0	F	0	0	0
8600	0	F	F	0	0	0	0	F	0	0	0
8700	F	F	F	0	0	0	0	F	0	0	0
8800	0	0	0	F	0	0	0	F	0	0	0
8900	F	0	0	F	0	0	0	F	0	0	0
8A00	0	F	0	F	0	0	0	F	0	0	0
8B00	F	F	0	F	0	0	0	F	0	0	0
8C00	0	0	F	F	0	0	0	F	0	0	0
8D00	F	0	F	F	0	0	0	F	0	0	0
8E00	0	F	F	F	0	0	0	F	0	0	0
8F00	F	F	F	F	0	0	0	F	0	0	0
9000	0	0	0	0	F	0	0	F	0	0	0
9100	F	0	0	0	F	0	0	F	0	0	0
9200	0	F	0	0	F	0	0	F	0	0	0
9300	F	F	0	0	F	0	0	F	0	0	0
9400	0	0	F	0	F	0	0	F	0	0	0
9500	F	0	F	0	F	0	0	F	0	0	0
9600	0	F	F	0	F	0	0	F	0	0	0
9700	F	F	F	0	F	0	0	F	0	0	0
9800	0	0	0	F	F	0	0	F	0	0	0
9900	F	0	0	F	F	0	0	F	0	0	0
9A00	0	F	0	F	F	0	0	F	0	0	0
9B00	F	F	0	F	F	0	0	F	0	0	0
9C00	0	0	F	F	F	0	0	F	0	0	0
9D00	F	0	F	F	F	0	0	F	0	0	0
9E00	0	F	F	F	F	0	0	F	0	0	0
9F00	F	F	F	F	F	0	0	F	0	0	0

NOTE: 0 = IN (Logical 0), F = OUT (Logical 1)

Table 2-15. Secondary Base Address For 256 Byte Short I/O (Continued)

ADDRESS	J23 PIN SETTINGS								J24, J25, J26 PIN SETTINGS		
	15-16	13-14	11-12	9-10	7-8	5-6	3-4	1-2	J24	J25	J26
A000	0	0	0	0	0	F	0	F	0	0	0
A100	F	0	0	0	0	F	0	F	0	0	0
A200	0	F	0	0	0	F	0	F	0	0	0
A300	F	F	0	0	0	F	0	F	0	0	0
A400	0	0	F	0	0	F	0	F	0	0	0
A500	F	0	F	0	0	F	0	F	0	0	0
A600	0	F	F	0	0	F	0	F	0	0	0
A700	F	F	F	0	0	F	0	F	0	0	0
A800	0	0	0	F	0	F	0	F	0	0	0
A900	F	0	0	F	0	F	0	F	0	0	0
AA00	0	F	0	F	0	F	0	F	0	0	0
AB00	F	F	0	F	0	F	0	F	0	0	0
AC00	0	0	F	F	0	F	0	F	0	0	0
AD00	F	0	F	F	0	F	0	F	0	0	0
AE00	0	F	F	F	0	F	0	F	0	0	0
AF00	F	F	F	F	0	F	0	F	0	0	0
B000	0	0	0	0	F	F	0	F	0	0	0
B100	F	0	0	0	F	F	0	F	0	0	0
B200	0	F	0	0	F	F	0	F	0	0	0
B300	F	F	0	0	F	F	0	F	0	0	0
B400	0	0	F	0	F	F	0	F	0	0	0
B500	F	0	F	0	F	F	0	F	0	0	0
B600	0	F	F	0	F	F	0	F	0	0	0
B700	F	F	F	0	F	F	0	F	0	0	0
B800	0	0	0	F	F	F	0	F	0	0	0
B900	F	0	0	F	F	F	0	F	0	0	0
BA00	0	F	0	F	F	F	0	F	0	0	0
BB00	F	F	0	F	F	F	0	F	0	0	0
BC00	0	0	F	F	F	F	0	F	0	0	0
BD00	F	0	F	F	F	F	0	F	0	0	0
BE00	0	F	F	F	F	F	0	F	0	0	0
BF00	F	F	F	F	F	F	0	F	0	0	0
C000	0	0	0	0	0	0	F	F	0	0	0
C100	F	0	0	0	0	0	F	F	0	0	0
C200	0	F	0	0	0	0	F	F	0	0	0
C300	F	F	0	0	0	0	F	F	0	0	0
C400	0	0	F	0	0	0	F	F	0	0	0
C500	F	0	F	0	0	0	F	F	0	0	0
C600	0	F	F	0	0	0	F	F	0	0	0
C700	F	F	F	0	0	0	F	F	0	0	0

NOTE: 0 = IN (Logical 0), F = OUT (Logical 1)

Table 2-15. Secondary Base Address For 256 Byte Short I/O (Continued)

ADDRESS	J23 PIN SETTINGS								J24, J25, J26 PIN SETTINGS		
	15-16	13-14	11-12	9-10	7-8	5-6	3-4	1-2	J24	J25	J26
F000	0	0	0	0	F	F	F	F	0	0	0
F100	F	0	0	0	F	F	F	F	0	0	0
F200	0	F	0	0	F	F	F	F	0	0	0
F300	F	F	0	0	F	F	F	F	0	0	0
F400	0	0	F	0	F	F	F	F	0	0	0
F500	F	0	F	0	F	F	F	F	0	0	0
F600	0	F	F	0	F	F	F	F	0	0	0
F700	F	F	F	0	F	F	F	F	0	0	0
F800	0	0	0	F	F	F	F	F	0	0	0
F900	F	0	0	F	F	F	F	F	0	0	0
FA00	0	F	0	F	F	F	F	F	0	0	0
FB00	F	F	0	F	F	F	F	F	0	0	0
FC00	0	0	F	F	F	F	F	F	0	0	0
FD00	F	0	F	F	F	F	F	F	0	0	0
FE00	0	F	F	F	F	F	F	F	0	0	0
FF00	F	F	F	F	F	F	F	F	0	0	0

NOTE: 0 = IN (Logical 0), F = OUT (Logical 1)

Step 4. Set Daughter Card Jumpers And Terminations

The following daughter card settings are discussed:

- Ethernet Single Channel AUI/10BaseT Daughter Card
- Dual Channel 10BaseT Ethernet Daughter Card
- Ethernet Dual Channel AUI Daughter Card

Ethernet Single Channel AUI/10BaseT Daughter Card

COMPONENT SIDE

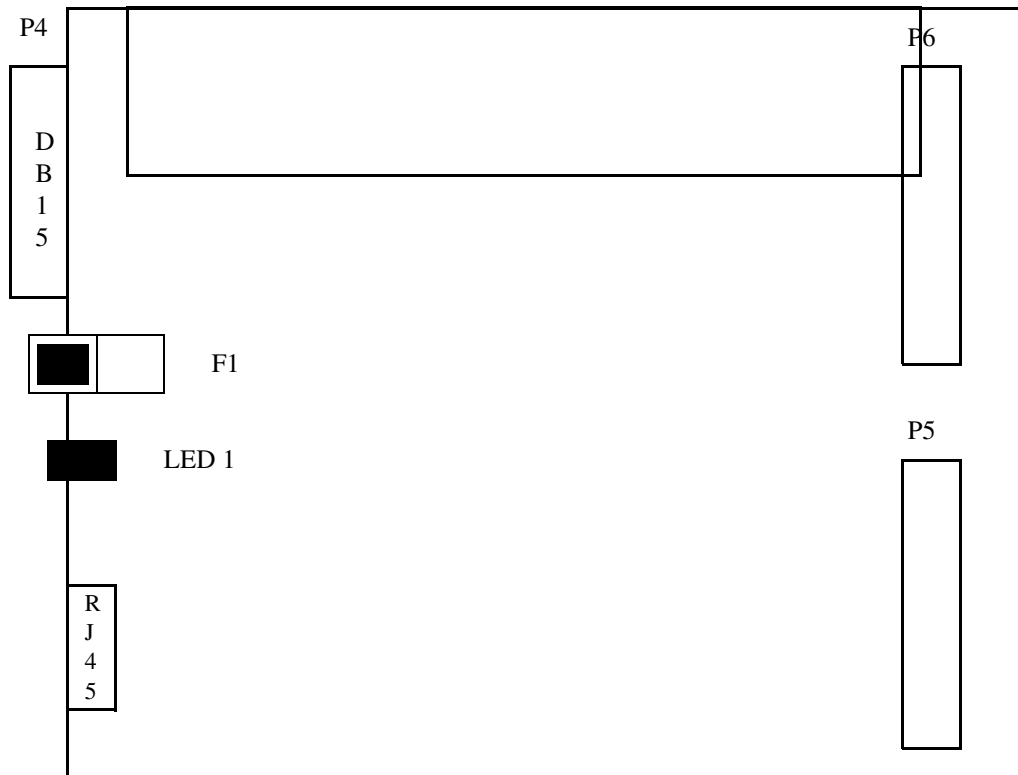

Figure 2-6. Ethernet Single Channel AUI/10BaseT Daughter Card

NOTE: LED3 is located on the solder side of the daughter card and is not shown in this illustration.

The Ethernet Single Channel AUI/10BaseT Daughter Card provides two types of connectors (DB15 & RJ45) as shown in Figure 2-7 above. However, only one connection (either AUI or 10BaseT) can be used at a time.

Table 2-16. Ethernet Single Channel Daughter Card LEDs

DESIGNATOR	FUNCTION	DESCRIPTION
LED1	10BaseT Link	When illuminated, indicates that 10BaseT link has been established.
LED3	+12 Volts	When illuminated, indicates that +12 Volts for the AUI connection is present.

Dual Channel 10BaseT Ethernet Daughter Card

COMPONENT SIDE

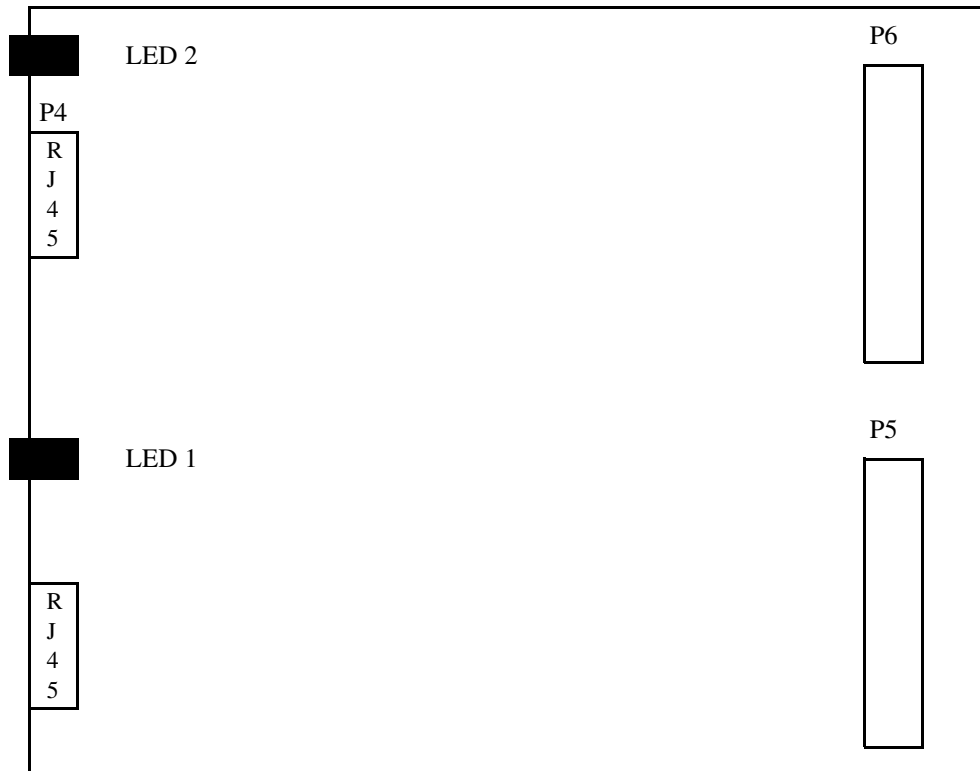

Figure 2-7. Dual Channel 10BaseT Ethernet Daughter Card

The Dual Channel 10BaseT Ethernet Daughter Card provides two RJ45 connectors as shown in Figure 2-7 above.

Table 2-17. Dual Channel 10BaseT Ethernet Daughter Card LEDs

DESIGNATOR	FUNCTION	DESCRIPTION
LED1	Daughter Card Channel 0 Link	When illuminated, indicates that the Daughter Card Channel 0 established a link.
LED2	Daughter Card Channel 1 Link	When illuminated, indicates that the Daughter Card Channel 1 established a link.

Ethernet Dual Channel AUI Daughter Card

COMPONENT SIDE

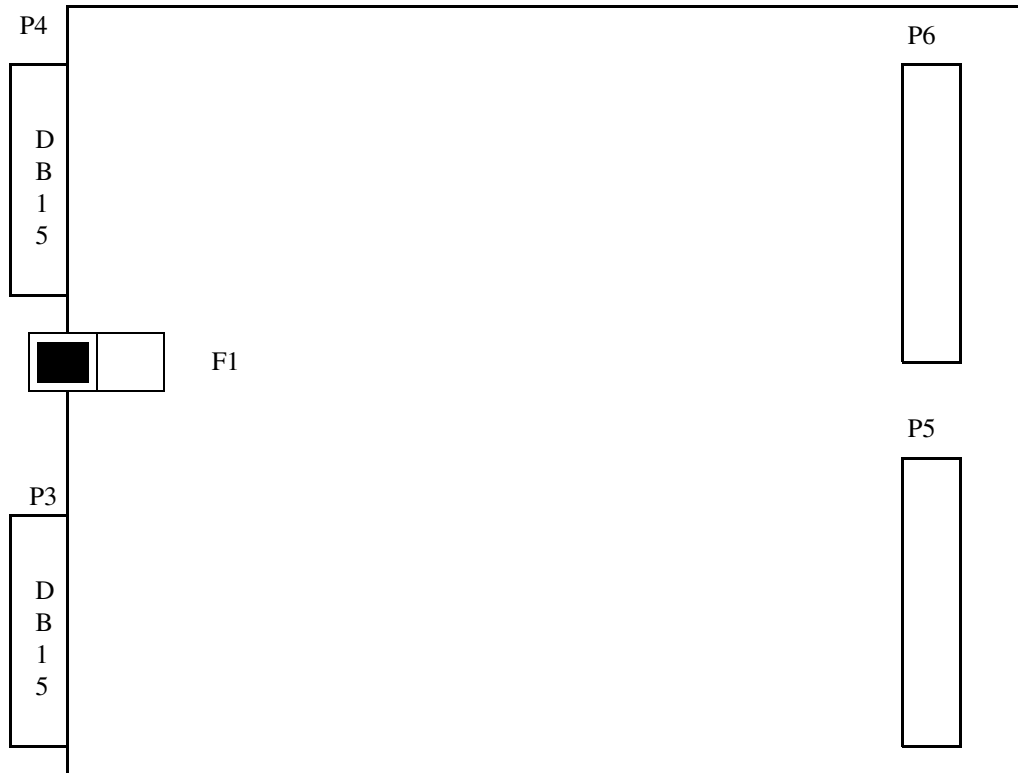

Figure 2-8. Ethernet Dual Channel AUI Daughter Card

NOTE: LED3 is located on the solder side of the daughter card and is not shown in this illustration.

The Dual Channel AUI Ethernet Daughter Card provides two DB15 connectors as shown in Figure 2-8 above.

Table 2-18. Ethernet Dual Channel AUI Daughter Card LEDs

DESIGNATOR	FUNCTION	DESCRIPTION
LED3	+12 Volts	When illuminated, indicates that +12 Volts is present.

Step 5. Power Off System

Once the board is configured, ensure that the host system and peripherals are turned OFF.

CAUTION

System power and peripheral power must be turned OFF before attempting to install the Condor. Failure to do so may result in severe damage to the board and/or system.

Step 6. Cabling Procedure

The cabling procedure depends on how you wish to configure the system. Your options are summarized in Table 2-19.

Table 2-19. Ethernet Cable Options

TO IMPLEMENT	CABLING OPTIONS
Ethernet Single Channel AUI/10BaseT Daughter Card	Front Panel I/O, connect a cable to P3 (RJ45) or P4 (DB15) on the front of the Ethernet Single Channel AUI/10BaseT Daughter Card. Note: <i>Only one cable or interface type can be used at a time.</i>
Dual 10BaseT Ethernet Daughter Card	Front Panel I/O, connect cables to P3 & P4 (RJ45) on the front of the Dual Channel 10BaseT Ethernet Daughter Card.
Dual AUI Ethernet Daughter Card	Front Panel I/O, connect cables to P3 & P4 (DB15) on the front of the Dual Channel AUI Ethernet Daughter Card.

RS232 Connectors And Cables

There are two 10 pin connectors (2x5 Headers) which are used as the RS232 port cable connectors. These connectors are the same type used for the second serial port I/O Extension-X.2 of PC compatible machines.

The connectors are labeled "SPA" and "SPB" (refer to Figure 2-1 or Figure 2-3 for location) for Serial Port A and Serial Port B respectively. Both RS232 ports on the Condor are configured as Data Terminal Equipment (DTE).

Installing The Cable(s) And Board

1. Ensure that you have the correct cables for your configuration. (Refer to "Cabling Procedure", above).
2. Make sure that the system and all peripherals are turned OFF.
3. Carefully slide the Condor into the VMEbus card slot. It should slide all the way in without any difficulty. If it doesn't, pull it out and check to make sure that there are no cables in the way.
4. Once the board is properly seated in the slot, tighten the captive mounting screws on each end of the front panel.
5. Connect Ethernet devices to the cable(s), following the directions given by the device manufacturers.

CHAPTER 3

MACSI HOST INTERFACE

Introduction

This chapter defines the MACSI host interface for the Interphase V/Ethernet 4221 Condor. The Condor and its MACSI host interface are designed to be backwards compatible with the Interphase V/Ethernet 4207 Eagle MACSI host interface. This compatibility exists to the extent that single port operation can be accomplished with virtually no alterations to an existing Eagle driver, and full 4 port operation can be provided with minimal changes

This interface provides support for:

- Offboard IOPBs, located in host memory
- Offboard postback of completed commands
- Multiple command completions
- Offboard postback of network statistics

Typographic Convention

When defining the layout of commands and the shared memory interface between the host and the Condor controller, three different conventions are used to specify the field offset:

Memory Address

The value in the far left column specifies an offset *in bytes* from the beginning of the Short I/O shared memory space, as follows:

Command Response Block																
Addr	15	14	13	12	11	10	9	8	7	6	5	4	3	2	1	0
0x730	Command Response Status Word (CRSW)															

This is indicated by the term *Addr* appearing in the heading block of the table.

Field Offset

The value in the far left column specifies the field offset. This value measures increments of 16 bits from the beginning of the record, and may be thought of as the displacement to be added to a *pointer to short integer* data type required to differentiate the particular field.

Onboard Command Queue Entry																
Offst	15	14	13	12	11	10	9	8	7	6	5	4	3	2	1	0
0x00	Queue Entry Control Register															
0x01	Reserved															

This construct is indicated by the term *Offst* appearing in the table heading, and is used for objects that may appear in different locations, either in host system memory or the Short I/O space.

Contiguous Data Allocation

Finally, contiguous allocated space may be specified with a starting address and an ending address, as follows:

Command Response Block																
Addr	15	14	13	12	11	10	9	8	7	6	5	4	3	2	1	0
0x73A to 0x73E	Reserved (8 Bytes)															

For addresses, the final number will always represent the last byte address of the allocated space. For offsets, it represents the final offset location, as follows:

Initialize Controller																
Offst	15	14	13	12	11	10	9	8	7	6	5	4	3	2	1	0
0x07	Controller Initialization Block Offset															
0x08 to 0x11	Reserved (20 Bytes)															

System Interface

This section defines *how* the host communicates with the controller. The shared memory interface is defined, and each major section described in detail. Full definitions for particular commands (*what* is communicated) can be found in a following section.

MACSI Organization

Ethernet MACSI for the Condor consists of eight major sections, as illustrated in the following memory map:

Table 3-1. MACSI Memory Map

MACSI Memory Map																
Addr	15	14	13	12	11	10	9	8	7	6	5	4	3	2	1	0
0x000 to 0x00F	Master Control Status Block (16 Bytes)															
0x010 to 0x01B	Master Command Queue Entry (12 Bytes)															
0x01C to 0xXXX	Command Queue Entries (12 Bytes * N)															
0xXXX to 0x72F	Onboard IOPBs (optional) (1812 - 12N Bytes)															
0x730 to 0x73F	Command Response Block (16 Bytes)															
0x740 to 0x763	Returned IOPB / Multiple Completion Return (36 Bytes)															
0x764 to 0x7AB	Configuration Status Block / Multiple Completion Return (72 Bytes)															
0x7AC to 0x7FF	Controller Statistics Block / Multiple Completion Return (84 Bytes)															

The *Master Control/Status Block (MCSB)* is used to pass and receive information relating to the overall functioning of the controller.

The *Master Command Entry (MCE)* and *Command Queue Entries (CQE)* are used to queue commands from the host to the controller. A Command Queue Entry (in either the CQE or MCE) is a 12-byte block containing all of the information needed for the 4221 to locate and execute a command issued by the host. Control commands, such as Initialize Controller, are submitted through the MCE. Transmit and Receive commands are submitted through the CQE.

Commands issued by the host are named IO Parameter Blocks, or IOPBs, and can either be located in the controller's Short I/O memory, in which case they are issued via an *onboard CQE*, or located in host system memory, in which the host uses an *offboard CQE*, and the controller DMA transfers the command in prior to execution. If located in onboard space, these IOPBs are located from the end of the last Command Queue Entry to the beginning of the Command Response Block.

The *Command Response Block (CRB)* and *Returned IOPB* areas are where the controller posts back status about completed commands to the host. Since interrupt bandwidth is the bottleneck resource in many network applications, the 4221 provides a *Multiple Completion* facility in which multiple commands can be returned to the host with a single interrupt, which uses not only the Returned IOPB space, but the entire rest of the Short I/O space.

Finally, the *Configuration Status Block* contains configuration information such as the firmware revision level. Typically, this is used only at system initialization time, and is overwritten by multiple completion commands during routine operation.

The *Controller Statistics Block* is a hold over from the old Eagle host interface. It is only updated on single channel daughtercards. A special command has replaced the function provided here, which allows more statistics to be reported for multiple ports. Again, as in the *Configuration Status Block* area, the *Controller Statistics Block* may be overwritten by multiple completion commands during routine operation.

NOTE:

The short I/O interface of the 4221 Condor is accessed through the secondary short I/O space only. Refer to "J23, J24, J25 & J26 Secondary Short I/O Address:" on page 33 for secondary short I/O address settings.

Master Control Status Block (MCSB)

The MCSB consists of a Master Status Register, which is used to report information from the controller to the host, and the Master Control Register, which provides infrequently used control functions to the host.

Table 3-2. Master Control Status Block

Master Control/Status Block																
Addr	15	14	13	12	11	10	9	8	7	6	5	4	3	2	1	0
0x000	Master Status Register															
0x002	Reserved															
0x004	Master Control Register															
0x006 to 0x00F	Reserved (10 Bytes)															

Master Status Register (MSR)

The MSR reports to the host whether the controller is functional or not. Two bits are used.

Table 3-3. Master Status Register

Master Status Register																
Addr	15	14	13	12	11	10	9	8	7	6	5	4	3	2	1	0
0x000															BOK	CNA

Controller not available (CNA)

This bit is set to 1 by the controller to indicate that it is not available for receipt of a command. This condition can be caused by a controller reset.

NOTE: *On the V/Ethernet 4207 Eagle, the controller was defined to be available when this bit is 0. On the 4221 Condor, controller available is signalled by the presence of Board OK.*

Board OK (BOK)

If 1, this bit indicates the controller has passed power up diagnostics, and is ready to accept commands.

Master Control Register (MCR)

The MCR provides the host with infrequently used services. These bits are both set and cleared by the host. The controller clears these bits on power up, and does not alter them at any other time.

Table 3-4. Master Control Register

Master Control Register																
Addr	15	14	13	12	11	10	9	8	7	6	5	4	3	2	1	0
0x004			SFEN	RST												SQM

Start queue mode (SQM)

This bit is provided for compatibility with the 4207 Eagle MACSI interface. When the host sets this bit, the controller returns a Command Complete interrupt, and then sets the QMS (Queue Mode Started) with all subsequent returned commands. Setting this bit produces no operational effect on the controller.

Controller Reset (RST)

This bit generates a controller reset. To ensure proper operation, the host system must set the bit for at least 50 microseconds, and then clear it. Use of this bit should not be necessary under normal operation, but typically only used during initialization.

Sysfail Enable (SFEN)

This bit is for backward compatibility to the 4207 Eagle. This bit does not perform any function. Use jumper J14, Pins 3-4 for Sysfail options. (See page 18)

Onboard Command Queue Entry

The host issues a command to the controller through a Command Queue Entry (CQE). Two types are provided: the Master Command Entry (MCE), located at offset 0x0010 is used to issue control commands, such as Initialize Controller, Report Network Statistics, and the like. The normal Command Queue Entry (CQE) is a circular queue of CQE elements located immediately after the MCE, which the host uses to post Transmit and Receive commands. The host specifies the number of elements in this circular list via the Initialize Controller command. The host submits a command by filling out the command IOPB structure, filling out a Command Queue Entry pointing to the command, and then setting the GO bit in the CQE. This signals the controller that the command is available, and it is picked up as a soon as possible.

If the host locates the IOPB in controller-provided Short I/O space, an *Onboard* Command Queue structure is used to submit the command. If the IOPB is located in host-provided system memory, an *Offboard* Command Queue structure is used.

Table 3-5. Onboard Command Queue Entry

Onboard Command Queue Entry																
Offst	15	14	13	12	11	10	9	8	7	6	5	4	3	2	1	0
0x00	Queue Entry Control Register															
0x01	Reserved															
0x02	Command Tag															
0x03	(4 Bytes)															
0x04	Reserved								Work Queue Number							
0x05	Reserved															

Queue Entry Control Register (QECR)

Table 3-6. Queue Entry Control Register

Queue Entry Control Register																
Offst	15	14	13	12	11	10	9	8	7	6	5	4	3	2	1	0
0x00											FIP	FOB				GO

This field controls the submission of the associated command. The following bits are defined:

Go/busy (GO)

This bit is set by the host to initiate action on the Command Queue entry. Before this bit is set, an IOPB must be assembled for this entry, and the entire Command Queue must be valid.

Upon detecting the Go bit set, the controller will move the CQE and IOPB into internal memory, and then clear this bit, indicating that the host may use these locations to submit another command.

Fetch offboard (FOB)

Setting this bit makes the Command Queue entry an offboard entry. Please see the following section for details.

Fetch offboard in progress (FIP)

This bit is used internally by the controller. It's value should not be used by the host driver.

IOPB Address

This field contains a pointer to the IOPB for the command being issued, and is specified as an offset, in bytes, from the start of Short I/O space. The space occupied by the IOPB will be available for re-use as soon as the controller clears the Go bit, indicating that the command has been received.

Command Tag

This field is returned unchanged to the host upon completion of the command, and may be used to uniquely identify the returned command. Typically, the host driver would place a pointer to a control structure associated with the command in this field. The controller does not use the value in this field in any way.

Work Queue Number

This field is not currently used, though the value entered will be returned to the host.

Offboard Command Queue Entry

The following fields are defined for an offboard Command Queue entry.

Table 3-7. Offboard Command Queue Entry

Offboard Command Queue Entry																
Offst	15	14	13	12	11	10	9	8	7	6	5	4	3	2	1	0
0x00	Queue Entry Control Register															
0x01	Dma Transfer Control Word															
0x02	Host Address (MSW)															
0x03	Host Address (LSW)															
0x04	Offboard Transfer Length								Work Queue Number							
0x05	Reserved															

Queue Entry Control Register (QECR)

The QECR field in the offboard entry is identical to the onboard version, except that the Fetch Offboard bit is set.

DMA Transfer Control Word

This field specifies how the controller should DMA transfer the data from host memory. This field is fully defined in the Common IOPB Structure definition, in the following section. Please refer there for full details.

Host Address

This field contains the physical address of the command, arranged in a big-endian order. The Host Address field points to the beginning of an 12 byte CQE structure located immediately (or 12 bytes) before the beginning of the IOPB in host system memory. After DMA transferring both the CQE and the IOPB from system memory, the controller will associate this new CQE with the IOPB, which affects primarily the Command Tag field.

Offboard Transfer Length

If the host places zero in this field, the controller will use the default value of 12 bytes + 36 bytes for the combined CQE/IOPB length. If in-line gathers are used which cause the size of the Transmit IOPB to exceed the default size of 36 bytes, the host needs to specify the total amount of data to transfer, in bytes, including both the CQE and the IOPB located in system memory.

Work Queue Number

This value is not used, but is reported back when the command completes.

Command Response Block (CRB)

The CRB is used by the controller to post completed commands back to the host. It consists of the following fields:

Table 3-8. Command Response Block

Command Response Block																
Addr	15	14	13	12	11	10	9	8	7	6	5	4	3	2	1	0
0x730	Command Response Status Word (CRSW)															
0x732	Reserved															
0x734 0x736	Command Tag (4 Bytes)															
0x738	Reserved							Work queue number								
0x73A to 0x73E	Reserved (8 Bytes)															

Command Response Status Word (CRSW)

The CRSW describes the nature of the response, and includes a handshake bit similar to the CQE Go bit to synchronize the controller and the host.

Table 3-9. Command Response Block

Command Response Block																	
Addr	15	14	13	12	11	10	9	8	7	6	5	4	3	2	1	0	
0x730								MC		QMS	CE	EX	ER	CC	CRBV		

Command Response Block Valid (CRBV)

The controller sets this bit after assembling the returned commands in host accessible memory. If Offboard postbacks are enabled, the returned commands will be located in both the onboard memory and the offboard memory. If commands are being returned one at a time (single completion), the entire IOPB will be located in the Returned IOPB space. If multiple commands are being returned, several Multiple Command return structures will be located in Short I/O, starting at the same location as used for the returned IOPB.

Command Complete (CC)

This bit is set when an IOPB is being returned. If this bit is set, a returned IOPB will be located in Short I/O.

Error (ER)

This bit is set with Command Complete when a returned IOPB completed with an error. Errored commands are never returned via the Multiple Completion mechanism. The nature of the error can be determined by examining the Return Status field in the returned IOPB.

Exception (EX)

This bit is set with Command Complete to indicate that the command completed with some kind of exception, which can be determined by examining the Return Status field in the returned IOPB.

Controller Error (CE)

This bit is set when a controller error is being returned. The controller error vector and level specified in the Initialize Controller IOPB will be used to generate the interrupt. The error code will be returned at offset 0x740 from the base of short I/O. The only error code currently supported is 0xff, *Controller Panic*, which will also include an ASCII string containing the file name and line number generating the panic, beginning at location 0x744 in short I/O. This string will be null terminated. The only recovery from a controller panic is to reset and re-initialize the controller. Panic's should not occur after initial system qualification.

Queue Mode Started (QMS)

This bit is set by the controller when the host sets the Start Queue Mode bit in the Master Control Register. Immediately the controller will acknowledge the setting of the SQM bit by generating a Command Complete interrupt, using the interrupt vectors and level specified in the Controller Initialization Block. Subsequently, all returned commands will have the QMS bit set.

Multiple Completion (MC)

The controller sets this bit when returning multiple completions with a single interrupt. When this bit is set, there is no returned IOPB in short I/O, but a list of IOPB completion structures instead. The number of commands being completed is located in the IOPB length field.

Command Tag

For a *single completed* command interrupt, this field contains the host-assigned Command Tag located in the Command Queue entry. It is not modified in any way by the controller.

For *multiple completed* commands, this field is cleared to zero. The command tags of the completed commands are written instead to a list of completed commands, using the Multiple Completed Returned IOPB structure, defined in the next section.

IOPB Length

For a *single completed* command interrupt, this field is undefined.

For *multiple completed* commands, this field contains the number of commands being returned.

Work Queue Number

For a *single completed* command interrupt, this field contains the host provided work-queue number specified in the Command Queue entry.

For *multiple completed* commands, this controller clears this field to zero.

Multiple Completed Returned IOPB Structure

When multiple commands are returned from the controller to the host with a single interrupt, the following structure is used to return individual commands, starting in the location of Short I/O normally used for the returned IOPB, and continuing for a maximum of 24 entries.

Table 3-10. Multiple Completed Returned IOPB Structure

Multiple Completed Returned IOPB Structure																
Addr	15	14	13	12	11	10	9	8	7	6	5	4	3	2	1	0
0x740 0x742	Command Tag (4 Bytes)															
0x744							Port			Work Queue Number						
0x746	Transfer Count															

Note: Port and Transfer Count fields are valid only if the posted element is a receive.

Command Tag

This field contains the command tag associated with the original command specified in the by the host in the Command Queue entry.

Port

For receives only, this field specifies the port on which in-coming frame was received. **This field is not valid for transmits.**

Work Queue Number

This field contains the work queue number provided by the host in the original Command Queue entry.

Transfer Count

For receives only, this field specifies the size of the received frame *subject to the same restriction as the returned frame size parameter in the normal receive IOPB*: you must subtract 4 from this value to get the actual number of bytes transferred. **This field is not valid for transmits.**

Configuration Status Block (CSB)

The controller uses the CSB to report the firmware and hardware configuration upon power up. These contents are valid from the time Board OK is asserted, to the time the controller posts back multiple completed returned commands in this space. The following fields are defined:

Table 3-11. Configuration Status Block

Configuration Status Block																
Addr	15	14	13	12	11	10	9	8	7	6	5	4	3	2	1	0
0x764	Reserved								Product Code							
0x766	Product Code															
0x768	Reserved								Product Variation							
0x76A	Reserved								Firmware Revision Level							
0x76C	Firmware Revision Level															
0x76E to 0x775	Firmware Revision Date															
0x776 to 0x793	Reserved (30 Bytes)															
0x794 to 0x799	Ethernet MAC Address (Port 0) (6 Bytes)															
0x79A to 0x79F	Ethernet MAC Address (Port 1) (6 Bytes)															
0x7A0 to 0x7A5	Ethernet MAC Address (Port 2) (6 Bytes)															
0x7A6 to 0x7AB	Ethernet MAC Address (Port 3) (6 Bytes)															

Product Code

The Interphase product code, represented as a 3-digit ASCII number.

Product Variation

The Interphase product variation code, represented as a 1-digit ASCII number.

Firmware Revision Level

The firmware revision level, represented as a 3-digit ASCII value.

Firmware Revision Date

The revision date of the installed firmware, represented as 8 ASCII digits. For example, a release data of January 15, 1994 would be represented as 01151994.

Ethernet MAC Addresses (Ports 0 - 3)

These field contain the current physical node addresses used to filter incoming receive packets for up to 4 Ethernet ports.

Controller Statistics Block

This space was used to report network statistics in the original Eagle MACSI implementation for single port Ethernet support. Statistics for multi-port controllers, or single port implementations not requiring Eagle MACSI compatibility, should be obtained via the Report Network Statistics IOPB. The contents of this area are undefined for multi-port controllers, and are overwritten in any case with multiple completed commands.

The Controller Statistics Block contains a variety of statistics concerning the transmission/reception of data from a single Ethernet port. By default, these statistics are continuously updated. However, these updates are disabled if the host is using the Multiple Completions Per Interrupt option and has specified a Maximum Group Count less than 13. This prevents the returned list of IOPB completions from being overwritten by the Controller Statistics Block.

Once the host initializes the controller to any extended level of MACSI over that supported by the Eagle, or any multi-port support, the contents of this block of memory will be zero-filled, and will not be updated with any further network statistics. The Report Network Statistics IOPB may be used to obtain network statistics in this case.

Table 3-12. 4207 Eagle Controller Statistics Block

Controller Statistics Block																
Addr	15	14	13	12	11	10	9	8	7	6	5	4	3	2	1	0
0x7AC to 0x7AF	Transmit Commands Submitted															
0x7B0 to 0x7B3	Transmit DMA Completions															
0x7B4 to 0x7B7	Transmit 82596 Completions															
0x7B8 to 0x7BB	Successful Transmits															
0x7BC to 0x7BF	Failed Transmits															
0x7C0 to 0x7C3	Transmit Completions Posted to Host															
0x7C4 to 0x7C7	Receive Commands Submitted															
0x7C8 to 0x7CB	Receives Dropped - No Pending Receive Command															

Controller Statistics Block																
Addr	15	14	13	12	11	10	9	8	7	6	5	4	3	2	1	0
0x7CC to 0x7CF	Receive 82596 Completions															
0x7D0 to 0x7D3	Successful Receives															
0x7D4 to 0x7D7	Failed Receives															
0x7D8 to 0x7DB	Receive DMA Completions															
0x7DC to 0x7DF	Receive Completions Posted to Host															
0x7E0 to 0x7FC	Reserved															

Transmit Commands Submitted

Total number of attempted frame transmissions (successful and unsuccessful).

Transmit DMA Completions

Total number of DMA transfers completed as the result of a transmit command.

Transmit 82596 Completions

Total number of frames that the Intel 82596 Ethernet chip has transmitted.

Successful Transmits

Total number of frames successfully transmitted.

Failed Transmits

Total number of unsuccessful frame transmissions.

Transmit Completions Posted to Host

Total number of frame completions posted to the Command Response Block and Returned IOPB.

Receive Commands Submitted

Total number of attempted message receptions (successful and unsuccessful).

Receives Dropped - No Pending Receive Command

Number of frame receptions lost or ignored because the host had no outstanding Receive commands posted to the Condor.

Receive 82596 Completions

Total number of frames received by the Intel 82596 Ethernet chip.

Failed Receives

Total number of messages unsuccessfully received.

Receive DMA Completions

Total number of DMA transfers completed as a result of a Receive command.

Receive Completions Posted to Host

Total number of Receive commands reported to the host via the Returned IOPB in the Command Response Block.

IO Parameter Blocks (IOPBs)

This section provides a detailed description of each of the commands used by the host to communicate with the controller.

Each command is listed below, along with the code associated with each command.

Table 3-13. IOPB Commands

Command Code	Name
0x41	Initialize Controller (includes Controller Initialize Block)
0x43	MAC Control IOPB
0x45	Change Default Node Address
0x50	Transmit
0x60	Receive
0x80	Initialize Multiple Completions per Interrupt
0x91	Report Network Statistics (includes Network Statistics Block)

Common IOPB Structures

Many commands share a set of common fields. These are documented here, rather than being duplicated for each IOPB in which they appear. Fields missing from the description of a particular command should be found here, in the definition of the common command fields.

Table 3-14. Common IOPB Structures

Common IOPB Structures																
Offst	15	14	13	12	11	10	9	8	7	6	5	4	3	2	1	0
0x00	Command Code															
0x01	Command Options															
0x02	Return Status															
0x03	Normal Completion Level								Normal Completion Vector							
0x04	Error Completion Level								Error Completion Vector							
0x05	DMA Transfer Control Word															

Command Code

This field specifies the command to be executed. Particular values are noted for each of the individual commands.

Command Options

This field specifies operational parameters or options to be associated with the execution of the command. The following subfields are available for all commands:

Table 3-15. Command Options

Command Options																
Offst	15	14	13	12	11	10	9	8	7	6	5	4	3	2	1	0
0x01																IE

Interrupt Enable (IE)

When set, the controller interrupts the host upon completion of the command, using the normal interrupt level and vector located in the IOPB if no error occurred, or the error interrupt level and vector otherwise.

Return Status

This field contains the returned status for the command. Any non-zero value indicates an error.

Normal Completion Level / Vector

This field contains the VMEbus interrupt level and vector used by the controller to notify the host of a successful command completion. These values are ignored when a command is posted as a multiple completion.

Error Completion Level / Vector

This field contains the VMEbus interrupt level and vector used to return commands which complete with errors.

DMA Transfer Control Word

This field contains control information which governs the DMA transfer of data between the host and the controller. The following subfields are defined:

Table 3-16. DMA Transfer Control Word

DMA Transfer Control Word																
Offst	15	14	13	12	11	10	9	8	7	6	5	4	3	2	1	0
0x05	Reserved			DIR	TT		MT		Address modifier							

Address modifier

This field contains the VMEbus address modifier used for the transfer. Refer to your system documentation for possible values for this field.

Memory type (MT)

This 2-bit field specifies the width of the data transfers. Permitted values are:

Table 3-17. Memory Type

Bit 9	Bit 8	Memory Type
0	0	Reserved (or Short I/O)
0	1	16 bit transfers
1	0	32 bit transfers
1	1	Reserved

Transfer type (TT)

This 2-bit field specifies the type of data transfer to be performed. Permitted values are:

Table 3-18. Transfer Type

Bit 11	Bit 10	Transfer Type
0	0	Normal Type
0	1	Block Mode
1	0	Reserved
1	1	VME D64 Block

Direction bit (DIR)

This bit is ignored.

Initialize Controller

This command allows the host to specify global configuration parameters, and initializes the controller for use within a particular system. Configurable parameters include the number of CQE entries, global DMA control parameters, and possible offboard locations for posting back returned commands. In addition, this command can be used to associate station addresses with each of the attached ports. The MAC Control IOPB may be used to control particular ports on the controller. The actual Initialize Controller IOPB points to a table containing the actual initialization values, named the Controller Initialization Block.

This command must be issued through the Master Command Entry.

Table 3-19. Initialize Controller

Initialize Controller																
Offst	15	14	13	12	11	10	9	8	7	6	5	4	3	2	1	0
0x00	Command Code															
0x01	Command Options															
0x02	Return Status															
0x03	Normal Completion Level								Normal Completion Vector							
0x04	Error Completion Level								Error Completion Vector							
0x05 0x06	Reserved (4 Bytes)															
0x07	Controller Initialization Block Offset															
0x08 to 0x11	Reserved (20 Bytes)															

Command Code

This field must be set to 0x41 to execute the Initialize Controller command.

Controller Initialization Block Offset

This field contains the offset from the start of Short I/O to the beginning of the Controller Initialization Block, in bytes.

Controller Initialization Block (CIB)

The CIB contains the actual values to use when initializing the controller. It may be located anywhere in Short I/O, though it makes sense to place it after the MCE and before the Command Response Block.

Table 3-20. Controller Initialization Block

Controller Initialization Block																
Offst	15	14	13	12	11	10	9	8	7	6	5	4	3	2	1	0
0x00	Reserved								Number of CQE Entries							
0x01	Special Network Options															
0x02	Reserved															
0x03 to 0x05	Ethernet Physical Address (Port 0) (6 Bytes)															
0x06 to 0x08	Ethernet Physical Address (Port 1) (6 Bytes)															
0x09 to 0x0B	Ethernet Physical Address (Port 2) (6 Bytes)															
0x0C to 0x0E	Ethernet Physical Address (Port 3) (6 Bytes)															
0x0F	Controller Completion Level								Controller Completion Vector							
0x10	Controller Error Level								Controller Error Vector							
0x11	DMA Burst Count															
0x12	Reserved															
0x13	Offboard CRB Transfer Word															
0x14	Offboard CRB Host Address (MSW)															
0x15	Offboard CRB Host Address (LSW)															

Number of CQE Entries

This field specifies the number of Command Queue entries to be used in the circular queue. Without using offboard IOPBs, the maximum number ranges between 30 and 37. With offboard CQEs, this number can be increased to 151 (1812 / 12). Choosing the correct value is important to ensure maximum performance of the controller.

Special Network Options

Originally, this field allowed the host to set several network related options, such as disabling receives, or disabling transmit CRC. A multiport controller requires that this type of control be associated with a particular port, rather than as a global configuration parameter, so these types of functions have been moved to the MAC Control IOPB. However, the ability to place all attached ports into promiscuous mode has been retained for diagnostics purposes.

Table 3-21. Special Network Options

Special Network Options																
Offst	15	14	13	12	11	10	9	8	7	6	5	4	3	2	1	0
0x01	PM		RSV	RSV	RSV			RSV	DI4	DI3	DI2	DI1				RSV

Reserved field (RSV)

Any field marked **Reserved** must be set to zero, else an error will be returned. This informs drivers which expect to be setting something with one of these bits that the function has been moved.

Disable on Initialization (DI1 through DI4)

Setting this bit causes the associated port to be disabled upon initialization, and requires that an *Enable Port* command be issued via the *MAC Control IOPB* to activate the port. This allows the host to initialize the controller, then set up various operational parameters for the individual ports, and then to enable the MAC port.

Promiscuous mode (PM)

Setting this bit will cause all attached ports to be placed in promiscuous mode.

Ethernet Physical Node Addresses

These four fields may contain a MAC address which will be used as the station address for the particular Ethernet port. If the contents of the field are zero, the station address stored in NVRAM will be used. Addresses specified here will *not* be saved in NVRAM.

Interrupt Levels and Vectors

The controller normal and controller error interrupt levels and vectors are used to report controller errors and status changes back to the host. This allows drivers to establish an independent entry point to handle exceptions, without affecting high-performance processing of network traffic.

DMA Burst Count

This field allows the host to control, to some extent, the characteristics of controller DMA transfers. Originally, the contents of this field determined the number of DMA transfers the controller would make in a single burst before releasing the bus and re-requesting it. The current bus controller uses a different mechanism, so values have been chosen that approximate that behavior, allowing substantial driver compatibility.

Using 0 (zero) in this field specifies "hog mode", where the controller after being granted the bus, the controller will transfer data until there is no data left.

A value between 1 and 0x20 (40 decimal) causes the controller, after being granted the bus, to transfer data until 1) there is no more data, or 2) 16 micro seconds elapses, or 3) one of the bus request lines on the VMEbus is asserted.

With a value between 0x21 and 0x80, the controller, after being granted the bus, will transfer data until 1) there is no more data to be transferred, or 2) 32 microseconds elapses.

With a value greater than 0x80, the controller will, after being granted the bus, transfer data until 1) there is no more data, or 2) 64 microseconds elapses.

Offboard CRB DMA Transfer Control Word

This work defines the DMA transfer of returned commands from the controller to the host, using the field definition found in the Common IOPB Structures definition.

Offboard CRB host address

These two fields contain the address in host memory to which the controller will post off-board Command response blocks. If these fields are zero, responses will be posted via on-board space only. When posting to the offboard location, the controller will DMA transfer the 208 bytes of memory contents starting at the beginning of the Command Response Block through the end of Short I/O. The host needs to make sure that adequate memory is mapped and available for this transfer.

When the controller sets the CRBV in the onboard space, this signals the contents of both the offboard and onboard CRB location are valid. When the host clears the CRBV bit, the controller will assume that the offboard location is available to write the next response.

MAC Control/Status

This command provides a host driver with two distinct levels of service to an Ethernet port located on the 4221.

First, it provides a general mechanism to control the Ethernet port, without the driver having to know any particulars about the actual Ethernet interface chip being used. Drivers written for long-term portability should use these features.

Second, it provides a transparent access to certain useful capabilities provided by the actual Ethernet interface chip, which could be quite useful in specialized applications like diagnostic programs, network monitor programs, custom point-to-point applications, or for tuning for specialized network application environment. Since these capabilities are intimately associated with a particular Ethernet interface chip, drivers using these will, by definition, not be as portable to future versions of this host-interface on controller using a different chip.

Most of these operations are only permitted on a port that has been disabled. Normally, the host will disable the port, change the operating parameters, and then enable the port, which activates it with the new operational characteristics. This means that the host may have to submit a number of MAC Control IOPBs sequentially in order to perform complex configurations on ports.

In order to disable a port, issue the MAC Control IOPB with the *SM* bit set in the *Command Options* field, and the *MAC Options* field set to zero.

Please note that various error are returned if illegal combinations of options are specified, or the port is in the wrong state to perform a particular action. Normally, there will be additional information printed to the controller console when each of these errors occurs.

Table 3-22. MAC Control / Status

MAC Control/Status																
Offst	15	14	13	12	11	10	9	8	7	6	5	4	3	2	1	0
0x00	Command Code															
0x01	Command Options															
0x02	Return Status															
0x03	Normal Completion Level							Normal Completion Vector								
0x04	Error Completion Level							Error Completion Vector								
0x05	DMA Transfer Control Word															
0x06	Buffer Address (MSW)															
0x07	Buffer Address (LSW)															
0x08	Reserved															
0x09	Transfer Size															
0x0A	Reserved															
0x0B	MAC Status / Control															
0x0C	Intel 82596 Status / Control Transmit Functions															
0x0D																
0x0E	Intel 82596 Status / Control Receive Functions															
0x0F																
0x10	Reserved															
0x11	MAC Returned Information															

Command Code

This field must contain 0x43 to execute the MAC Control IOPB.

Command Options

Table 3-23. Command Options

Command Options																
Offst	15	14	13	12	11	10	9	8	7	6	5	4	3	2	1	0
0x01						AR	AN	AA		Port			SRX	STX	SM	IE

Interrupt Enable (IE)

Defined in Common IOPB Structures.

Set MAC options (SM)

When this bit is set, the state of the specified MAC is updated as per those bit settings specified in the MAC Status/Control word. If this bit is not set, the current settings will be reported back in the MAC Status/Control word when the command completes.

Set 596 transmit options (STX)

When this bit is set, those settings specified in the Intel 82596 Transmit Status/Control word are applied to the specified port.

Set 596 receive options (SRX)

When this bit is set, those settings specified in the Intel 82596 Receive Status/Control word are applied to the specified port.

The best way to use these would be to submit the MAC Control command with none of the Set bits, which causes the current status to be returned in the various control words. Then, modify those subfields desired, and return the command, with the appropriate Set bit active.

Port selector

This subfield selects the particular port to which the command is applied. Valid ports numbers range from 0 to 3.

Abort ALL (AA)

Setting this bit causes the controller to abort all pending receives for all ports. If the AR bit is also set, these will be returned to the host with the appropriate error code set. Without the AR bit set, aborted commands are silently discarded. This bit will not abort non-designated receives: use the next bit for that. When this bit is set, the port designator specified in the Command Options field is ignored, and no further processing of the IOPB is done. The MAC Control IOPB will be returned to the host after all commands have been aborted.

Abort ANY (AN)

Setting this bit causes the controller to abort any pending receives that were submitted for non-designated ports, with the ANY bit set in the Command Options field of the Receive IOPB. As with the AA bit, these aborted commands will be silently discarded unless the Abort Report bit is also set. When this bit is set, the port designator specified in the Command Options field is ignored, and no further processing of the IOPB is done. The MAC Control IOPB will be returned to the host after all commands have been aborted.

Abort Report (AR)

Setting this bit causes commands aborted with either the AA or the AN bit to be reported back to the host with the appropriate error code set. Setting this bit has no effect on pending receives for particular ports aborted via the Abort Pending bit in the MAC Status/Control field.

Setting all three of these bits (AA, AN, AR) will cause all pending receives posted for all ports, plus all non-designated pending receives to be returned to the host with the appropriate error set.

Return Status

Full error return status details will be available after the module level design is complete.

Buffer address

This field contains the address of the 6-byte Individual Address when the command is used to set the station address, or a list of possible addresses when setting up Multiple Individual Address or Multicast Address filtering. Otherwise the contents of this field are ignored. With the correct Memory Type specified in the DMA Control Word (bit 9 = 0, bit 8 = 0), this value could be an offset into Short I/O. The contents of the memory location specified in this way will be reserved for the controllers use, and not available to the host, until the IOPB is returned. Writing additional information into this field while the controller is processing the IOPB may cause undefined behavior.

Transfer size

This field contains the size in bytes of the data to be transferred from the location specified above.

MAC status/control

This field provides a general set of MAC level functions, which drivers can use to control the particular port without any reference to the actual Ethernet control chip used on the controller. Drivers using these functions will be portable to other Interphase Ethernet controllers employing this same MACSI host interface, though they may use different front end chips. Programs, such as diagnostics and specialized network monitoring programs, can use the following two fields to obtain direct access to more specialized functions provided by the particular Ethernet control chips employed.

Table 3-24. MAC Status / Control

MAC Status/Control																
Offst	15	14	13	12	11	10	9	8	7	6	5	4	3	2	1	0
0x0B								TDR	LPB	MC	PM	IA	AR	AP	EM	IM

Initialize MAC (IM)

Setting this bit (along with the SM bit in the Command Options word) resets the port. This sets all management counters for the port to zero, resets the physical interface circuitry, and aborts any pending receives. Without the Enable MAC bit set, neither transmits nor receives will be active, and the port will respond only to control commands issued through the Control MAC IOPB.

Setting this bit resets the port: promiscuous mode is disabled, multicast is disabled, any supplied multiple individual addresses are lost. All of the internal memory structures for the port are reinitialized, and the port is reinitialized with power on default values.

Enable/Disable MAC (EM)

With SM set, setting this bit enables the MAC for both transmits and receives. If this bit is not set, the port will not transmit, nor will it receive. Without SM, the bit reports status.

Abort Pending (AP)

Causes any pending receives for this port to be aborted.

Abort Report (AR)

With this bit set, any pending receives aborted with the AP bit or by setting the Initialize MAC bit will be returned to the host with the appropriate error code set.

Set Individual address (IA)

With SM set, this bit changes the individual address for the port. The new station address needs to be located by the Buffer Address field defined above. Without SM, the current station address for the port will be returned. Please refer to the *Buffer Address* field definition for details on how to locate this in Short I/O.

Enable Promiscuous mode (PM)

With SM set, enables promiscuous reception on the port. Otherwise returns status.

Enable multi-cast receptions (MC)

With SM set enables native multi-cast receptions. On the Intel 596, this corresponds to Multi-Cast All, in which all multicast frames are returned to the host. Use the multicast setup options specific to the 596 defined below to set up particular filters. Otherwise reports current status.

Enable loopback (LPB)

With SM set places port in the native loopback mode. With the 596, this corresponds to External Loopback. Additional modes are provided by the 596-specific functions below. Otherwise reports loopback status of port.

Perform TDR test (TDR)

If SM bit is set, causes a TDR test to be executed on the port, and returns the number of 10 MHz ticks which elapsed between the beginning of the test and the collision which ended it. Otherwise returns the results for the last test executed, or zero.

Intel 82596 Status/Control – Transmit Functions

This field provides direct host access to several functions provided by the Intel 82596 Ethernet control chip controlling the transmit function. Users of these functions should be aware that they are quite specific to the Intel 82596, and should code accordingly. Users who desire portability should use the generic MAC control functions provided above.

These functions are fully documented in the Intel documentation. They are not intended to be used without referring to that source.

Note: The specific source document referred to here is the Intel 32 Bit Local Area Network (LAN) Component User's Manual, 1992 (Order No. 296853-001). Use of an alternate Intel document for reference may have the necessary information but may not correspond to the page numbers listed below.

Table 3-25. Intel 82596 Transmit Status / Control

Intel 82596 Transmit Status/Control																
Offst	15	14	13	12	11	10	9	8	7	6	5	4	3	2	1	0
0x0C	Interframe Spacing							EXP PRI			LIN PRI			DB	BM	
0x0D	Max Entry			AR	Slot Time											

Backoff method (BM) (p. 4-131)

This parameter determines when to start the back-off timeout.

Disable backoff (DB) (p. 4-141)

Disables the backoff algorithm implemented in the 82596.

Linear priority (LIN PRI) (p. 4-130,131)

Specifies the number of slot times that the 82596 waits after Interframe Spacing or after Backoff before enabling transmission.

Exponential priority (EXP PRI) (p 4-131)

Extends the range from which the random number for backoff is selected.

Interframe spacing (p 4-133)

Specifies the time period, in transmit unit clocks, that the 82596 must wait after detecting the later of the two events; the last bit has been transmitted, or Carrier Sense becomes inactive.

Slot time (p. 4-133,134)

Specifies Slot Time, in transmit unit clocks, for the network. This can be changed to optimize the network to specific application environments.

Automatic retry (AR) (p. 4-139)

Causes the 82596 to automatically retry transmission if a collision is detected before the last 30 bits of the Preamble sequence.

Max retry (p. 4-134)

Specifies the maximum number of transmission retries (after a collision) that the 82596 performs before transmission is aborted.

Intel 82596 Status/Control – Receive Functions

This field provides equivalent direct access to 82596 receive-related functions.

Table 3-26. Intel 82596 Receive Status / Control

Intel 82596 Receive Status/Control																
Offst	15	14	13	12	11	10	9	8	7	6	5	4	3	2	1	0
0x0E	LPBK		MONM		ADDR LEN					MI	MS	MA	BD	SB		
0x0F	DG	DU	TDR				Min Frame Length									

Save bad frames (SB) (p. 4-129)

When set bad frames (CRC error, Alignment error, etc.) are sent to the host.

Broadcast disable (BD) (p. 4-134)

Disables reception of frames with a Broadcast destination address or Multicast of all 1's.

Multicast all (MA) (p. 4-140)

Enables the 82596 to receive all frames that have a multicast address in the destination address fields.

Multicast setup (MS) (p. 4-141)

This command loads the 82596 with the Multicast-IDs that should be accepted. The filtering done on these is not perfect, and some unwanted frames may be accepted. A list of addresses may be specified with the *Buffer Address* field: the controller uses the default address length, combined with the *Transfer Size* parameter to determine the number of addresses provided. Multicast filtering may be active with multiple individual addresses: in this case the host will need to issue the command twice in order to provide both the list of multicast addresses to filter, and the list of multiple individual addresses to filter.

Multiple individual address (MI) (p. 4-141)

Enables the 82596 to receive multiple individual address frames using the same hashing mechanism as used for multicast address filtering. A list of addresses may be specified with the *Buffer Address* field: the controller uses the default address length, combined with the *Transfer Size* parameter to determine the number of addresses provided.

Address length (p. 4-129)

Determines the length, in bytes, of the addresses used by the 82596. These include Individual, Source, Destination, Multicast, or Broadcast addresses. This value is used to determine the number of entries in any provided list of addresses, either for Multicast or multiple individual address filtering.

Monitor mode (MONM) (p. 4-128)

Refer to the 82596 documentation for a full description of monitor functions.

Loopback (LPBK) (p. 4-130)

Configures the loopback operation of the 82596. Refer to the 82596 documentation for a full description of the modes of operation.

Min frame length (p. 4-138)

Specifies the minimum received frame size, not including preamble (in bytes).

Time domain reflectometry test (TDR) (p. 4-150)

This operation activates the Time Domain Reflectometry test. The result is returned in the MAC returned information field. Refer to the 82596 documentation for full details of the returned values.

Dump 82596 internal registers (DU) (p. 4-153)

This command will cause the contents of the various 82596 registers to be transferred to the location in system memory specified by the Buffer Address field.

Diagnose (DG) (p. 4-165)

Triggers an internal self-test that checks the 82596 hardware, and reports back a successful or failed status in the MAC returned information field.

MAC returned information

This field may contain returned information from the MAC. Otherwise it will be set to all zeros.

Change Default Node Address

This command is used to change the 48 bit physical address associated with any of the attached ports. It also can be used to manage both the factory and user addresses stored in NVRAM, either by setting them to new values, or by restoring preset values.

This command must be issued through the Master Command Entry.

Table 3-27. Change Default Node Address

Change Default Node Address																
Offst	15	14	13	12	11	10	9	8	7	6	5	4	3	2	1	0
0x00	Command Code															
0x01	Command Options															
0x02	Return Status															
0x03	Normal Completion Level								Normal Completion Vector							
0x04	Error Completion Level								Error Completion Vector							
0x05 to 0x09	Reserved (10 Bytes)															
0x0A to 0x0C	Physical Node Address (6 Bytes)															
0x0D to 0x11	Reserved (10 Bytes)															

The only change to this IOPB is the addition of a port selector sub-field in the Command options field.

Command Code

This field must contain 0x45 to execute the Change Default Node Address IOPB.

Command Options

Table 3-28. Command Options

Command Options																
Offst	15	14	13	12	11	10	9	8	7	6	5	4	3	2	1	0
0x01	PFM						RUD	RFD		Port				RMC	UUD	IE

Interrupt enable (IE)

As defined in the Common IOPB Structures.

Update user default (UUD)

Setting this bit updates the NVRAM-stored user default physical node address for the specified port with the value provided in the Physical Node Address field.

Restore manufacturer's address (RMC)

This field restores the original manufacturer's MAC address, using information stored in the CIB.

Port selector

This field determines the port to which the action will be applied. Permitted values range from 0 to 3.

Restore factory default (RFD)

Setting this bit restores the current address from the factory assigned default stored in NVRAM. This action eliminates any currently stored user default for the specified port.

Restore user default data (RUD)

Setting this bit restores the current address from the user data stored in the CIB.

Program factory MAC address (PFM)

Setting this bit updates the factory assigned default address stored in NVRAM from the contents of the Physical Node Address field. This bit is intended only for internal Interphase use, and should not be documented or used externally.

Transmit

The Transmit command causes the controller to DMA transfer the specified frame from host memory, and then transmit it (if possible) through the specified Ethernet port.

Table 3-29. Transmit

Transmit																
Offst	15	14	13	12	11	10	9	8	7	6	5	4	3	2	1	0
0x00	Command Code															
0x01	Command Options															
0x02	Return Status															
0x03	Normal Completion Level							Normal Completion Vector								
0x04	Error Completion Level							Error Completion Vector								
0x05	DMA Transfer Control Word															
0x06	Buffer Address (MSW)															
0x07	Buffer Address (LSW)															
0x08	Transfer Size (MSW)															
0x09	Transfer Size (LSW)															
0x0A to 0x0E	Reserved (10 Bytes)															
0x0F	Reserved															
0x10	Reserved															
0x11	Reserved															

Command Code

This field must contain 0x50 to execute the Transmit IOPB.

Command Options

Table 3-30. Command Options

Command Options																
Offst	15	14	13	12	11	10	9	8	7	6	5	4	3	2	1	0
0x01							RSV		DMC	Port			IG	RSV	RSV	IE

Interrupt enable (IE)

As defined in Common IOPB Structures.

In-line gather (IG)

Setting this bit allows the host to define the frame location in system memory as a set of address/count pairs. These gather elements are specified directly in the remainder of the IOPB, and do not require a separate DMA of a gather-list.

Port selector

This field specifies the port to which the frame will be transmitted. Valid ports range from 0 to 3.

Disable multiple completion (DMC)

Setting this bit prevents the frame from being returned using the multiple completion mechanism.

Reserved bit (RSV)

Any bit marked **Reserved** must be set to zero. Failure to do so will cause an error to be returned to the host.

Transmit -- In-Line Gathers

By setting the IG bit in the Command Options field, the driver may define the data space for the frame to be transmitted as a set of address/count pairs, or a gather list. By incorporating this directly in the Transmit IOPB, the controller saves a separate DMA transfer of the gather list before beginning the DMA of the frame itself.

The gather list begins with the element immediately after the DMA Transfer Control Word (which controls the transfer of each of the elements), and can continue for up to 8 elements. Note that if more than 2 elements are included, that the resulting size of the IOPB exceeds normal, and the IOPB length field in the CQE must be set in order for the controller to correctly process the command. This also means that fewer Command Queue Entries can be located in short I/O if onboard IOPBs are employed.

Also note that the fields have been set up for long-word alignment to the structure elements, at the expense of supporting fewer onboard CQE/IOPB's. This is to accommodate RISC-based systems which make non-longword aligned accesses difficult and expensive.

Table 3-31. Transmit - In-Line Gathers

Transmit - In-Line Gathers																
Offst	15	14	13	12	11	10	9	8	7	6	5	4	3	2	1	0
0x06	Number of Elements															
0x07	Total Transfer Count															
0x08	Reserved															
0x09	Element Transfer Count															
0x0A	Buffer Address (MSW)															
0x0B	Buffer Address (LSW)															
0x0C	Reserved															
0x0D	Buffer Address (MSW)															
0x0F	Buffer Address (LSW)															
	...															

Number of Elements

This field contains the number of gather elements included in the IOPB. The only physical limit on this value is that the size of the total IOPB to be processed by the controller must fit in the IOPB length field in the CQE. Practically, however, this value should not exceed 4.

Total transfer count

This field contains the total number of bytes to be transferred for all elements. This value must match the sum of all the element transfer counts.

Element transfer count

This field contains the number of bytes located at the physical address associated with this element.

Buffer address

This field contains the VMEbus physical address for the data associated with this gather element.

Receive

The host provides the controller with Receive commands, which specify the host resources to be used for incoming frames. As frames come in, the controller transfers them to the specified host memory locations, updates the provided Receive commands, and posts them back to the host.

Receive commands may be allocated to particular ports, or they may be placed in a "free pool", and the controller will use them as needed. This is done with the ANY bit in the Command Options field. A suggested practice would be to post a minimum number of Receive commands for each port, to prevent any port from getting starved out by activity on other ports, and then post a pool of receives to be used by all ports.

The controller will use available internal resources to buffer incoming frames, so that the host does not have to meet tight timing windows in order to prevent dropped packets. However, receive performance will largely be a function of how many commands may be aggregated into a single multiple completion return, which will increase as the available number of host-supplied commands increases.

Finally, receives posted back using the multiple completion mechanism will not be separated by port number. The host will need to scan the list of returned frames to separate out by ports, if necessary.

Table 3-32. Receive

Receive																
Offst	15	14	13	12	11	10	9	8	7	6	5	4	3	2	1	0
0x00	Command Code															
0x01	Command Options															
0x02	Return Status															
0x03	Normal Completion Level								Normal Completion Vector							
0x04	Error Completion Level								Error Completion Vector							
0x05	DMA Transfer Control Word															
0x06	Buffer Address (MSW)															
0x07	Buffer Address (LSW)															
0x08	Reserved															
0x09	Max Transfer Size / Actual Transfer Size															
0x0A	Reserved															
0x0B	Packet Type / Length Field															
0x0C to 0x0E	Source Address (6 Bytes)															
0x0F	Reserved															
0x10	Reserved															
0x11	Reserved															

Command Code

This field must contain 0x60 to execute the Receive IOPB.

Command Options

Table 3-33. Command Options

Command Options																
Offst	15	14	13	12	11	10	9	8	7	6	5	4	3	2	1	0
0x01	AN Y								DMC	PORT				RSV	RSV	IE

Interrupt enable

As defined in the Common IOPB Structures section.

Port selector

This field specifies the port to which the receive resources will be allocated. Valid ports range from 0 to 3.

Disable multiple completion (DMC)

Setting this bit prevents a returned frame from being returned using the multiple completion mechanism.

Non-port designated (ANY)

Setting this bit allows the receive resources specified in the command to be used for any port with incoming traffic.

Buffer Address

This field contains the host VMEbus physical address for the start of the incoming data.

Maximum / Actual Transfer Size

When supplied by the host to the controller this field contains the maximum amount of data that can be transferred to the specified location. This should be no smaller than the largest frame expected to be received, which for Ethernet normally is 1518 bytes. When the controller returns this command for a received frame, this field will contain the actual amount of data transferred, plus 4. Thus, a received frame of 64 bytes have 68 as the value returned in this field.

Packet Type / Length Field

When a particular MAC is placed in certain monitor modes, network traffic may be reported to the host without any actual frame data being transferred. In this case, this field contains the Message Type frame header when operating on an Ethernet compatible network, and the Length Field on an 802.3 network.

Source Address

When so monitoring the network, the source address for the incoming frame will be contained in this field. Neither this field nor the previous will be used for normal frame reception activity.

Initialize Multiple Completions

This command enables the controller to return multiple completed commands to the host with a single completion via the Command Response Block, with a single (optional) interrupt.

When commands are completed using this mechanism, the returned IOPB is replaced with a substantially different Multiple Completion Returned Command structure. Please refer to the system interface section of this chapter for details.

Once the host has enabled multiple completions, the controller will still post back individually completed commands, for any of the following conditions:

Only a single command required posting back (the multiple completion mechanism will never be used to post back less than two commands)

The **Disable Multiple Completion** bit is set in a particular Transmit or Receive IOPB

The IOPB completed with error or exception. Such IOPBs will *always* be returned from the controller to the host as a single completion.

When posting a group of commands as a multiple completion, the controller will ignore all interrupt related information in the individual IOPBs, including the Interrupt Enable bit in the Command Options word, and the interrupt level and vector, and will use the related fields provided in the Initialize Multiple Completions instead. However, commands returned via the single completion mechanism will always use the interrupt information contained in the individual IOPB.

The Initialize Multiple Completion IOPB must be issued through the Master Command Entry.

Table 3-34. Common IOPB Structures

Common IOPB Structures																
Offst	15	14	13	12	11	10	9	8	7	6	5	4	3	2	1	0
0x00	Command Code															
0x01	Command Options															
0x02	Return Status															
0x03	Normal Completion Level							Normal Completion Vector								
0x04	Error Completion Level							Error Completion Vector								
0x05	Reserved															
0x06	Control Flags															
0x07	Group Interrupt Level							Group Interrupt Vector								
0x08	Minimum Group Count															
0x09	Maximum Group Count															

Command Code

This field must be set to 0x80 to execute the Initialize Multiple Completions command.

Command Options

No special options are available for this command. Refer to Common IOPB structures for defined options.

Return Status

There are not particular errors currently defined for this IOPB.

Control Flags

Table 3-35. Control Flags

Control Flags																
Offst	15	14	13	12	11	10	9	8	7	6	5	4	3	2	1	0
0x06															MIE	MEN

Enable Multiple Completions (MEN)

Setting this bit enables posting of multiple commands completions. Issuing the command with this bit cleared disables multiple command completions.

Interrupt on Multiple Completion (MEI)

Setting this bit causes the controller to issue an interrupt to the host when posting a multiple command completion. Not setting this bit prevents any interrupt from being posted, requiring the host to poll the Command Response Block for returned completions.

Group Interrupt Level / Vector

This field specifies the VMEbus interrupt level and vector to be used when posting back multiple command completions. These values will override any values specified in the individual IOPBs being returned.

Minimum Group Count

This field is ignored.

Maximum Group Count

This field specifies the maximum number of IOPBs to be returned per completion. For the definition of the returned structure, please refer to the System Interface section of this chapter.

A maximum of 4 entries will fill the Returned IOPB area. 13 overwrites the Configuration Status Block, and 24 fills the remainder of short I/O. Setting this value any less than 24 will significantly constrain the performance of the controller.

Report Network Statistics

Table 3-36. Report Network Statistics

Report Network Statistics																
Offst	15	14	13	12	11	10	9	8	7	6	5	4	3	2	1	0
0x00	Command Code															
0x01	Command Options															
0x02	Return Status															
0x03	Normal Completion Level								Normal Completion Vector							
0x04	Error Completion Level								Error Completion Vector							
0x05	DMA Transfer Control Word															
0x06	Buffer Address (MSW)															
0x07	Buffer Address (LSW)															
0x08	Max Transfer Size / Actual Transfer Size															
0x09	Timer Tick Interval															
0x0A to 0x11	Reserved (18 Bytes)															

The Report Network Statistics Command can be used to obtain network statistics for any Ethernet port available on the controller. These statistics are accumulated since the last controller reset. The host may also specify a fixed duration time interval to expire between automatic posting back of network statistics. A separate command must be issued for each port for which statistics are desired.

This command must be submitted through the MCE to work queue 0.

Command Code

This field must contain the value 0x91 to execute the Report network statistics command.

Command Options

Table 3-37. Command Options

Command Options																
Offst	15	14	13	12	11	10	9	8	7	6	5	4	3	2	1	0
0x01										Port						IE

Interrupt enable (IE)

As defined in Common IOPB Structures.

Port selector

This field specifies the port for which the statistics will be reported. Valid ports range from 0 to 3.

Return Status

This field will contain any return status from the controller to the host. A value of 0 indicates that no error occurred, and the command completed successfully.

Host Memory Buffer Address

This field contains the VMEbus address of host memory to which the controller will post the network statistics. Note the distinct locations for most significant word (MSW) and least significant word (LSW) in this address.

Max Transfer Size

This field contains the maximum number of bytes allocated by the host to accommodate the information to be transferred by the controller. When the command is complete, this field in the returned IOPB will contain the actual number of bytes transferred by the controller.

Timer Interval

This field contains an integer which will be used by the controller to set up a fixed interval timer. Each time this timer expires, the network statistics for the particular port will be posted to the host, along with a returned IOPB, just as if the host had submitted a separate IOPB. The timer interval will be calculated by multiplying the value provided in this field by 250 milliseconds.

Submitting a new Report Network Statistics Command for a particular port will cause any existing repeating statistics command to be replaced with the value in the new command. Using this, a host can cancel a repeating statistics command by submitting a new command with this field set to 0.

Timer intervals are maintained on a per port basis.

Network Statistics Block

Table 3-38. Network Statistics Block

Network Statistics Block																
Offst	15	14	13	12	11	10	9	8	7	6	5	4	3	2	1	0
0x00	Data Valid Indicator															
0x01	Port Indicator															
0x02 0x03	Transmits Submitted															
0x04 0x05	Transmits Completed															
0x06 0x07	Transmits Failed															
0x08 0x09	Collisions															
0x0A 0x0B	Receives Submitted															
0x0C 0x0D	Receives Returned															
0x0E 0x0F	Receives Dropped (Resources)															
0x10 0x11	Receives Dropped (Errors)															

Data Valid Indicator

When the data is transferred to the host, this field will contain a non-zero value. By clearing this field to zero, the host can avoid inadvertent accesses to dirty data for repeating network statistics commands.

Port Indicator

This field will contain an integer ranging between 0 and 3 indicating the port for which the statistics are being returned.

Transmits Submitted

This field contains the number of transmit commands submitted to the controller for the particular Ethernet port.

Transmits Completed

This field contains the number of transmit commands for the particular port that have been posted back to the host.

Transmits Failed

This field contains the number of transmit commands for the particular port that could not be transmitted out over the media, due to excessive collisions.

Collisions

This field contains the total number of collisions for the particular interface.

Receives Submitted

This field contains the number of receive commands submitted to the controller by the host for the particular port.

Receives Returned

This field contains the number of completed receive commands returned from the controller to the host. This represents the number of successful received frames.

Receives Dropped (Resources)

This field contains the number of receives from a particular port that were dropped due to no host-supplied receive command.

Receives Dropped (Errors)

This field contains the number of receives in error. This includes in-coming frames dropped because of internal out-of-resources errors in the controller.

APPENDIX A

SPECIFICATIONS

VMEbus Specifications

DTB Master	A16, A24, A32, D08 (EO), D16, D32: BLT, D64: BLT
DTB Slave	A16, D08 (EO), D16, D32
Requester	Any of R(0-3), Static RWD, ROR
Interrupter	Any of I(1-7), Dynamic D08 (O)

Power Requirements

Dual AUI Ethernet Motherboard	5.70A typical @ +5V DC (+/- 5%) 6.20A maximum @ +5V DC (+/- 5%) 7mA maximum @ +12V DC (+/- 5%) See note. 30mA maximum @ -12V DC (+/- 5%)
Dual 10BaseT Ethernet Motherboard	5.70A typical @ +5V DC (+/- 5%) 6.20A maximum @ +5V DC (+/- 5%) 7mA maximum @ +12V DC (+/- 5%) See note. 30mA maximum @ -12V DC (+/- 5%)
Dual AUI Daughter Card	0.80A typical @ +5V DC (+/- 5%) 0.60A maximum @ +5V DC (+/- 5%) 0.00A maximum @ +12V DC (+/- 5%) See note.
DUAL 10BaseT Daughter Card	0.80A typical @ +5V DC (+/- 5%) 0.60A maximum @ +5V DC (+/- 5%) 0.00A maximum @ +12V DC (+/- 5%) See note.
Single Channel Ethernet Daughter Card	0.70A typical @ +5V DC (+/- 5%) 0.50A maximum @ +5V DC (+/- 5%) 0.00A maximum @ +12V DC (+/- 5%) See note.

NOTE

Each Condor AUI port provides +12 volts at the cable connector (DB15). An additional .5 amps (maximum) of +12 volts may be required for each AUI transceiver (or box) connected to the Condor.

Mechanical (Nominal)

Length	233 mm
Width	160 mm
Thickness	20 mm
Weight	.45 Kg

Operating Environment

Temperature	0-55 degrees Centigrade
Relative Humidity	10% - 90% Noncondensing
Air Flow	250 CFM Minimum

Fuse

The AUI version of the Condor has a 1.5 amp fuse (F1) used to protect the +12 volts power when provided by the Condor. LITTLEFUSE part number is PN 273-01.5. To determine the location of the fuse on the board, refer to the appropriate board layout.

Reliability

MTBF per Bellcore Standard	209,697 hours
----------------------------	---------------

APPENDIX B

CONNECTOR PINOUTS AND CABLING

Overview

This chapter contains the connector pinouts and cabling information needed for various Condor configurations. The tables in this chapter are listed below.

VMEbus Connectors

- Table C-39 P1 Connector Signal Descriptions (All Versions)
- Table C-40 P2 Connector For Motherboards Which Only Use P2 Row B

Ethernet Connector And Pinouts

- Table C-41 RJ45 (10BaseT) Connector Signals
- Table C-42 DB15 (AUI) Connector Signals

RS232 Connector And Cable Pinouts

- Table C-43 Serial Connector Pinouts (SPA And SPB)
- Table C-44 Suggested RS232 Cable Pinout

VMEbus Connectors

The following tables show the pin numbers and signal description for the P1 and P2 VMEbus Connectors.

- Table C-39 - P1 Connector Signal Descriptions (All Versions)
- Table C-40 - P2 Connector For Motherboards Which Only Uses P2 Row B

P1 Connector

Table C-39. P1 Connector Signal Descriptions (All Versions)

PIN	Row A Signal Mnemonic	Row B Signal Mnemonic	Row C Signal Mnemonic
1	D00	BBSY*	D08
2	D01	BCLR*	D09
3	D02	ACFAIL*	D10
4	D03	BG0IN*	D11
5	D04	BG0OUT*	D12
6	D05	BG1IN*	D13
7	D06	BG1OUT*	D14
8	D07	BG2IN*	D15
9	GND	BG2OUT*	GND
10	SYSCLK	BG3IN*	SYSFAIL*
11	GND	BG3OUT*	BERR*
12	DS1*	BR0*	SYSRESET*
13	DS0*	BR1*	LWORD*
14	WRITE	BR2*	AM5
15	GND	BR3*	A23
16	DTACK	AM0	A22
17	GND	AM1	A21
18	AS*	AM3	A20
19	GND	AM3	A19
20	IACK	GND	A18
21	IACKIN*		A17
22	IACKOUT*		A16
23	AM4	GND	A15
24	A07	IRQ7*	A14
25	A06	IRQ6*	A13
26	A05	IRQ5*	A12
27	A04	IRQ4*	A11
28	A03	IRQ3*	A10
29	A02	IRQ2*	A09
30	A01	IRQ1*	A08
31	-12V DC		+12V DC
32	+5V DC	+5V DC	+5V DC

P2 Connector Row B Only Version

Table C-40. P2 Connector For Motherboards Which Only Uses P2 Row B

PIN	Row A Signal Mnemonic	Row B Signal Mnemonic	Row C Signal Mnemonic
1		+5V DC	
2		GND	
3			
4		A24	
5		A25	
6		A26	
7		A27	
8		A28	
9		A29	
10		A30	
11		A31	
12		GND	
13		+5V DC	
14		D16	
15		D17	
16		D18	
17		D19	
18		D20	
19		D21	
20		D22	
21		D23	
22		GND	
23		D24	
24		D25	
25		D26	
26		D27	
27		D28	
28		D29	
29		D30	
30		D31	
31		GND	
32		+5V DC	

Ethernet Connectors and Pinouts

The Condor supports both the AUI and 10BaseT versions of the Ethernet 802.3 specification. The card will have a 15 pin "D" connector used for the AUI signals and a RJ45 connector for unshielded twisted pair (10BaseT). Transformers are used with both interfaces to isolate the external cable from the interface electronics.

The single-channel daughter card is manufactured with both of connectors. The connector used by the channel is automatically selected by the hardware when a cable is connected.

A dual-channel daughter card and dual channel motherboard are manufactured with only one type of connector for each channel. For example, a dual channel AUI board will have two DB 15 connectors. A dual channel 10BaseT board will have two RJ45 connectors.

10BaseT Connector Signals

The 10BaseT signals and connector pinout for the RJ45 connector are shown in the following table.

Table C-41. RJ45 (10BaseT) Connector Signals

Symbol	Dir	Pin	Description
TXP _x	O	1	Transmit Data Positive
TXN _x	O	2	Transmit Data Negative
RXP _x	I	3	Receive Data Positive
RXN _x	I	6	Receive Data Negative

AUI Connector Signals

The AUI signals and connector pinout for the DB15 connector are shown in the following table.

Table C-42. DB15 (AUI) Connector Signals

Symbol	Dir	Pin	Description
GND	-	1	Digital Ground
CLSN _x	I	2	Collision
TRMT _x	O	3	Transmit
GND	-	4	Digital Ground
RCV _x	I	5	Receive Data
GND	-	6	Positive 12 Volts Return
-	-	7	No Connection
GND	-	8	Digital Ground
CLSN _x *	I	9	Collision Inverted
TRMT _x *	O	10	Transmit Inverted
GND	-	11	Digital Ground
RCV _x *	I	12	Receive Inverted
12VDC	-	13	Positive 12 Volts
GND	-	14	Digital Ground
-	-	15	No Connection

RS232 Connector and Cable

Table C-43. Serial Connector Pinouts (SPA and SPB)

PIN	MNEMONIC	TYPE	DESCRIPTION
1	-	-	Unconnected (DCD)
2	DSR	I	Data Set Ready
3	RXD	I	Receiver Data Input
4	RCTS	I/O	RTS/CTS, (shorted to pin 6)
5	TXD	O	Transmitter Data Output
6	RCTS	I/O	RTS/CTS, (shorted to pin 4)
7	DTR	O	Data Terminal Ready
8	-	-	Unconnected (RI)
9	GND	-	Signal Ground
10	-	-	Unconnected

NOTE: The same cable for the second Serial Port for PC compatible systems can be used for the 4221 Condor. This cable can be built or bought off-the-shelf from many computer stores. The cable pinout is shown in the following table:

Table C-44. Suggested RS232 Cable Pinout

10-PIN	DB-25 PIN	MNEMONIC	DESCRIPTION
1	8	DCD	Data Carrier Detect
2	6	DSR	Data Set Ready
3	3	RXD	Receiver Data Input
4	4	RTS	Request to Send
5	2	TXD	Transmitter Data
6	5	CTS	Clear To Send
7	20	DTR	Data Terminal Ready
8	22	RI	Ring Indicator
9	7	GND	Signal Ground
10	-	-	Unconnected

NOTE: Both RS232 ports on the Condor are configured as Data Terminal Equipment (DTE). With this connector and cable configuration, a NULL modem cable may be required to connect a terminal to the board.

APPENDIX C

ERROR CODES

The Return Status word in the command response contains information pertaining to the status of the IOPBs returned in the Command Response Block. Error codes are reported in hexadecimal format.

<u>HEX CODE</u>	<u>DESCRIPTION</u>
0x110	VMEbus Error An attempted VME bus transfer generated a system bus error.
0x115	Abort Pending Error The errored command is being returned in response to an abort command issued by the MAC Status IOPB.
0x120	Transmit Error An error occurred while attempting to transmit frame. Currently, transmit commands are returned immediately after the DMA transfer of the frame data from the host is complete, so transmit errors will not be reported back to the host. Use the network statistics command to obtain counts of errored transmits instead.
0x121	Network Interface Not Initialized An operation was attempted on an uninitialized network interface.
0x141	Illegal Option An illegal option was specified in the command options word of an IOPB. Note that only obvious illegal combinations will generate this error: fully sanity checking for all possible illegal combinations is not feasible.
0x142	Illegal MAC Option An illegal option was specified in the MAC status word of the MAC Status IOPB.
0x143	Illegal Parameter The submitted IOPB could not be processed due to an error in one of the fields.
0x144	Bus Error A system bus error occurred. This error code is identical in meaning to 0x110, and will be replaced by it.
0x145	Link Status Error An attempt was made to perform some function using the MAC Status IOPB on a network interface that was in a Link UP state.

INDEX

Numerics

82596 4, 81, 82

A

AA 79

Abort ALL (AA) 79

Abort ANY (AN) 79

Abort Pending (AP) 81

Abort Report (AR) 80, 81

Air Flow 100

AN 79

ANY 91

AP 81

AR 80, 81

B

binary 2

board ok (BOK) 57

BOK 57

byte 2

C

cabling 51

 dual 10BaseT daughter card 51

 dual AUI daughter card 51

 installing 52

 single channel AUI/10BaseT daughter card 51

CC 62

CE 63

CIB 74

CNA 57

Command Complete (CC) 62

Command Options 71, 79, 86, 88, 91, 94, 96

Command Queue Entry (CQE) 59, 60

Command Response Block (CRB) 56, 62, 74, 93

Command Response Block Valid (CRBV) 62

Command Response Status Word (CRSW) 62

Command Tag 60, 63

compatibility

 Eagle 53

Configuration Status Block (CSB) 56, 65

connectors

 dual 10BaseT daughter card 49

 dual AUI daughter card 50

 Ethernet 101, 102, 104

 RS232 101, 106

 single channel AUI/10BaseT daughter card 48

 VMEbus 101, 102

contiguous data allocation 54

Control Flags 94

Control MAC IOPB 80

Controller Error (CE) 63

Controller Initialization Block (CIB) 74

Controller Initialization Block Offset 73

Controller Panic 63

controller reset (RES) 58

Controller Reset (RST) 58

Controller Statistics Block 56

CPU core 5, 6

CQE 56, 59, 74, 88

CRB 56, 62, 76

CRBV 62, 76

CRSW 62

CSB 65

customer service 7

D

Data Valid Indicator 97

daughter card

 dual 10BaseT 8, 49, 99

 dual AUI 8, 50, 99

 single AUI/10BaseT 8

 single channel AUI/10BaseT 48, 99

DB15 101, 104

Default Node Address 85

DIR 72

Direction bit (DIR) 72

Disable multiple completion (DMC) 88, 91

DMA Burst Count 75

DMA Control Word 80

DMA engine 4

DMA Transfer Control Word 61, 71, 88

DMC 88, 91

E

Electrostatic Discharge (ESD) 7

EM 81

Enable Multiple Completions (MEN) 94

Enable/Disable MAC (EM) 81

ER 63

error

 abort pending 107

 bus 107

 illegal MAC option 107

 illegal option 107

 illegal parameter 107

 link status 107

 network interface not initialized 107

 transmit 107

 VMEbus 107

Error (ER) 63

Error Completion Level / Vector 71

Ethernet MAC Addresses 66

Ethernet Physical Node Addresses 75

EX 63
Exception (EX) 63

F

feature list 2
fetch offboard entry (FOB) 60
Fetch offboard in progress (FIP) 60
field offset 54
FIP 60
firmware revision level 66
FOB 60
Front End Channel (FEC) 3, 4
fuse 14, 100

G

go bit 59
grounding 14

H

hexadecimal 2
hog mode 75
Host Address 61

I

IA 81
IE 71, 86, 88
IG 88
IM 80
Initialize Controller 73
Initialize MAC (IM) 80
In-line gather (IG) 88
In-Line Gatherers
 Transmit 88
Interrupt enable (IE) 71, 86, 88
Interrupt on Multiple Completion (MEI) 94
interval timer 96
IO Parameter Blocks (IOPBs) 56, 70
IOPB 56
IOPB Address 60
IOPB Commands 70
IOPB Length 63

J

jumpers 16
 firmware options 17, 18
 FLASH 16
 flash programming 17
 primary channel address modifiers 20
 primary short I/O base address 21
 primary short I/O size 19
 reset enable 19
 secondary channel address modifiers 19
 secondary short I/O base address 33

secondary short I/O size 18
VME bus grant 17

L

LEDs
 board status 15
 diagnostic 14
 dual 10BaseT daughter card 49
 dual AUI daughter card 50
 run mode 16
 single channel AUI/10BaseT daughter card 48
Local Bus (LBUS) 4
longword 2
loopback (LPB) 81
LPB 81

M

MAC Control/Status 77, 80
MAC Status Word 93
MACSI 53, 55
Master Command Entry (MEC) 56, 59, 85, 93
master control register (MCR) 58
master control/status block (MCSB) 55, 57
master status register (MSR) 57
MC 63, 81
MC68EC030 5
MCE 56, 74
MCR 58
MCSB 55, 57
MEC 59
MEI 94
memory address 53
Memory Type 72, 80
Memory type (MT) 72
MEN 94
monitor mode 15
motherboard
 10BaseT 8, 9, 12, 99
 AUI 8, 11, 13, 99
MSR 57
MT 72
multi-cast receptions (MC) 81
Multiple Completions 56, 63, 64, 93

N

Network Statistics Block 97
Non-port designated (ANY) 91
Normal Completion Level / Vector 71

O

Offboard Transfer Length 61

P

PFM 86
PM 75, 81
POST mode 15
power requirements 99
Product Code 65, 68
Program factory MAC address (PFM) 86
Promiscuous mode (PM) 75, 81

Q

QECR 60
QMS 63
Queue Entry Control Register (QECR) 59, 60
Queue Mode Started (QMS) 63

R

Receive 82, 90, 93, 98
Relative Humidity 100
Reliability 100
Report Network Statistics 67, 95
Reserved field (RSV) 75
Restore factory default (RFD) 86
Restore manufacturer's address 86
Restore user default data 86
Return Status 80, 94, 96
returned IOPB 56
revision date 66
RFD 86
RJ45 101, 104
RMC 86
RST 58
RSV 75
RUD 86
run mode 15

S

Serial Port 106
Set 596 receive options (SRX) 79
Set 596 transmit options (STX) 79
Set Individual address (IA) 81
Set MAC options (SM) 79
Short I/O 5, 56
SM 79
specification
 VMEbus 1
specifications
 mechanical 100
 operating environment 100
 power 99
 VMEbus 99
SQM 58
SRX 79
start queue mode (SQM) 58

STX 79

T

TDR 81
TDR test 81
Temperature 100
Transfer Count 64
Transfer type (TT) 72
Transmit 81, 87, 93, 97
TT 72

U

Update user default (UUD) 86
UUD 86

V

variation code 65
VMEbus master 4

W

word 2
Work Queue Number 60, 63, 64

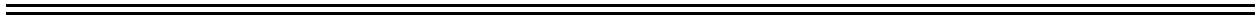

Free Manuals Download Website

<http://myh66.com>

<http://usermanuals.us>

<http://www.somanuals.com>

<http://www.4manuals.cc>

<http://www.manual-lib.com>

<http://www.404manual.com>

<http://www.luxmanual.com>

<http://aubethermostatmanual.com>

Golf course search by state

<http://golfingnear.com>

Email search by domain

<http://emailbydomain.com>

Auto manuals search

<http://auto.somanuals.com>

TV manuals search

<http://tv.somanuals.com>