



Progressive Scan Camera

CV-M77

Operation Manual

Camera: Revision A
Manual: Version 1.0



THE MECHADEMIC COMPANY

DECLARATION OF CONFORMITY



EMC Conformity according to council directive 89/336/EEC EMC (Electromagnetic compatibility)

As defined by the captioned directive

JAI Corporation
1-18-2 Hakusan, Midori-Ku, Yokohama,
Kanagawa, Japan

herewith declare that:

Category: CCD camera
Description: Closed circuit television
Model/Type: CV-M77

comply with the following provisions applying to it standards:

EN 50081-2 (Generic emission standard part 2)
EN 50082-2 (Generic immunity standard part 2)

JAI Corporation
German Industry Center
1-18-2 Hakusan, Midori-ku
Yokohama
Kanagawa 226-0006

Japan

Phone +81 45-933-5400
Fax +81 45-931-6142

www.jai-corp.co.jp

A handwritten signature in cursive script, appearing to read 'T. Matsuura', written over a horizontal line.

T. Matsuura
Quality Assurance Department

Date of issue: 2001. Nov. 13

1	General	5
2	Standard Composition	5
3	Main Features	5
4	Camera Housing and Dimensions	6
5	Pin Assignment	7
5.1	12-pin Multi-connector (DC-IN/SYNC.).....	7
5.2	6-pin Multi-connector (RS 232C/TRIGGER).....	7
5.3	9-pin DSUB-connector (RGB/SYNC.).....	8
5.4	Input and Output Circuits.....	9
5.4.1	Video input.....	9
5.4.2	Trigger input.....	9
5.4.3	HD and VD input.....	9
5.4.4	HD, VD, PCLK, WEN and EEN output.....	9
6	Functions and Operation	10
6.1	Input/Output of HD/VD Signal.....	10
6.1.1	Input of External HD/VD signals.....	10
6.1.2	Output of Internal HD/VD signals.....	10
6.2	Continuous operation.....	10
6.3	External Trigger Mode.....	10
6.3.1	Edge Pre-select Trigger Mode.....	10
6.3.2	Pulse Width Control Trigger Mode.....	11
6.3.3	Frame-delay Readout Mode.....	12
6.3.4	Long Time Exposure Mode.....	12
6.4	Timing diagram for Horizontal and Vertical Sync. Video Output.....	13
6.5	Timing diagram for Edge Pre-select mode.....	14
6.6	Timing diagram for Pulse Width Control mode.....	14
6.7	Timing diagram for Frame-delay Readout mode.....	14
6.8	Timing diagram for Long Time Exposure mode.....	15
7	Configuring the camera using the serial interface	16
7.1	Mode Setting using ASCII commands via the RS-232C port.....	16
7.2	Communication setting.....	16
7.3	Command Protocol.....	16
7.3.1	Receiving Data (Camera->PC).....	17
7.4	RS232C Cable Connections.....	18
8	Switch Settings	19
8.1	Mode Settings by Switch.....	19
8.2	Signals by Switch Settings.....	19
8.2.1	SW301 switch.....	19
8.2.2	SW302 switch.....	20
8.2.3	SW303 switch.....	20
9	Jumper settings	21
9.1	Jumper locations.....	21
9.2	Jumper table.....	22
10	CV-M77 Camera Control Tool	23
11	Specifications	25
11.1	Spectral sensitivity.....	26
12	Appendix	27
12.1	Precautions.....	27
12.2	Typical CCD Characteristics.....	27
12.2.1	Smear.....	27
12.2.2	Aliasing.....	27
12.2.3	Blemishes.....	27

12.2.4 Patterned Noise 27
12.3 References 27
13 Users Record 28
14 Index 28

1 General

The CV-M77 camera is a compact RGB color progressive scan camera designed for automated imaging applications. The 1/3" CCD sensor with square pixels and primary mosaic filter offers a superb image quality and the build in DSP assures high color reproduction.

The camera incorporates several triggered modes and various shutter functions to capture moving objects and to control the light. All camera mode settings can be controlled via an RS-232C interface or by the switch at the rear of the camera.

The CV-M77 camera is ideal for demanding color applications such as color inspection, gauging and color printing.

The latest version of this manual can be downloaded from: www.jai.com.

The latest version of the Camera Control Tool software can be downloaded from: www.jai.com.

2 Standard Composition

The standard camera composition consists of the camera main body and the operation manual.

3 Main Features

- New 1/3" full frame progressive scan interline transfer CCD
- RGB Primary color mosaic filters on chip
- 1034 (h) x 779 (v) 4.65µm square pixels (1024 x 768 pixels read out) – XGA format
- 25 full frames RGB video output per second
- Internal, external HD/VD or random trigger synchronization
- Edge pre-select and pulse width controlled external trigger modes
- Programmable shutter speed from 1.5 H to 791 H
- Long time exposure with external VD pulse interval
- Frame delay readout for edge pre-select and pulse width controlled shutter
- Exposure enable EEN, write enable WEN and pixel clock output
- Short ASCII commands for fast mode setup via serial port
- Windows Camera Control Tool software to setup the camera via RS 232C
- Pixel clock output optional

4 Camera Housing and Dimensions

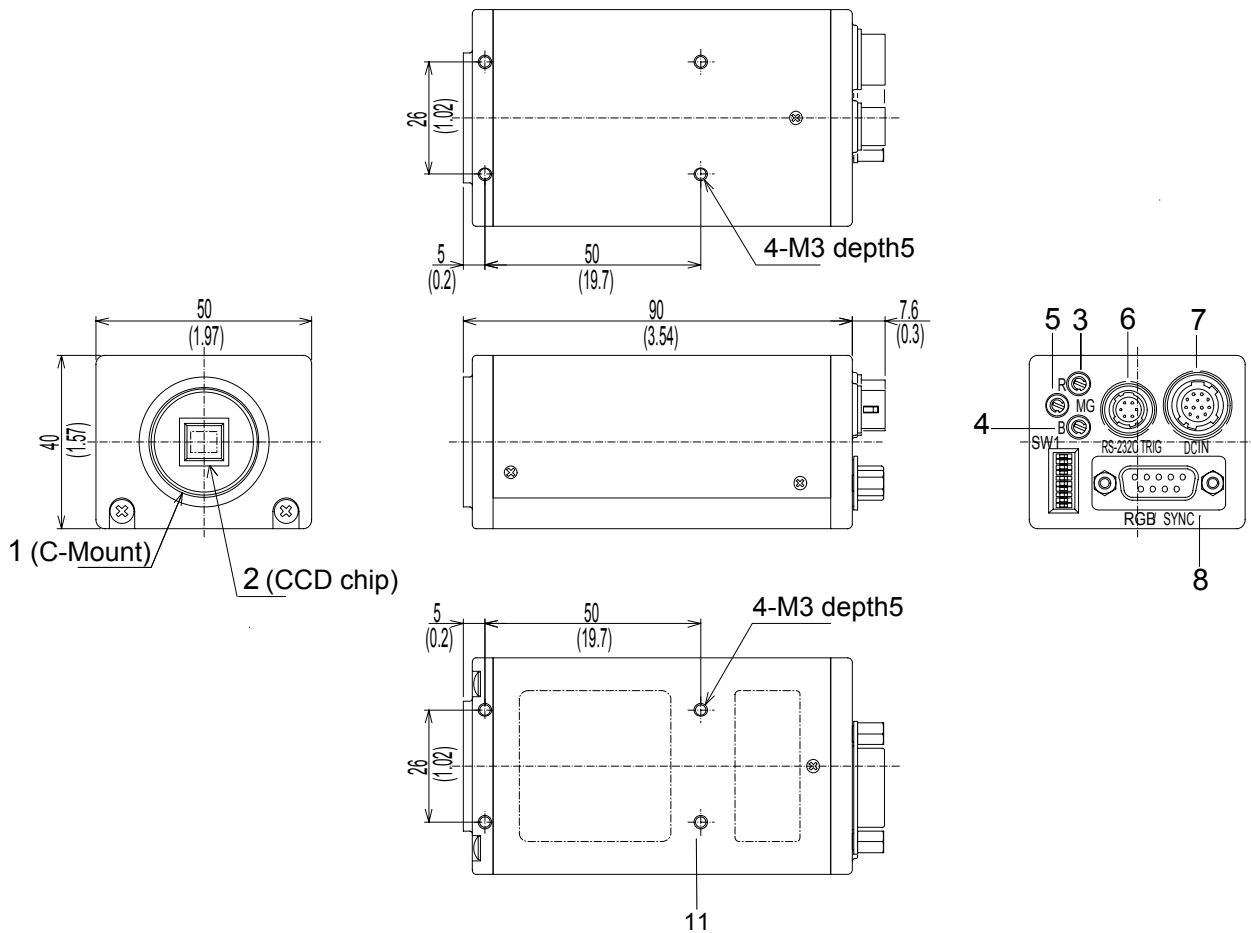

Figure 4-1

- | | |
|----|--------------------------------------------------------------------------------------------------|
| 1 | Lens mount of C-mount type. *1) |
| 2 | 1/3" interline transfer CCD progressive scan sensor with square pixels and primary mosaic filter |
| 3 | R Gain Potentiometer. To adjust Red gain level manually. |
| 4 | B Gain Potentiometer. To adjust Blue gain level manually. |
| 5 | MG Gain Potentiometer. To adjust Master gain level manually. |
| 6 | 6 pin connector for RS 232C signals, input of ext. trigger pulse and WEN output. |
| 7 | 12 pin connector for +12V DC power and HD/VD input/output. |
| 8 | 9 pin D-Sub connector for RGB video output, video synchronization output and pixel clock output. |
| 9 | Switch to set shutter speed and function mode. |
| 10 | Screw holes for tripod mounting plate (optional plate) |
| 11 | 4 M3 mounting threads. *2) |

*1) **Note:** Rear protrusion on C-mount lens must be less than 6mm (0.24-inch approx.)

*2) **Note:** Notice depth of thread is only 5mm. Too long screws may harm inside electronics.

5 Pin Assignment

5.1 12-pin Multi-connector (DC-IN/SYNC.)

Type: HR10A-10R-12PB-01 (Hirose male)
Seen from rear.

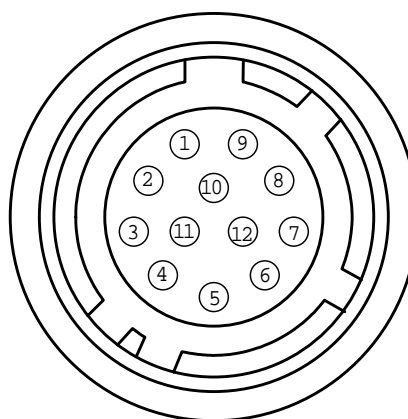

Pin No.	5.1.1.1 Signal	5.1.1.2 Remarks
1	5.1.1.3 GND	
2	+12V DC input	
3	GND	
4	NC	
5	GND	
6*	Ext.HD input	SW-S301.1 "ON" for 75Ω termination, SW-S303.1 "OFF" for HD output
7*	Ext.VD input	SW-S301.2 "ON" for 75Ω termination, SW-S303.2 "OFF" for VD output
8	GND	
9*	NC	PCLK out: JP305 "short", JP306 "open"
10*	WEN	NC: JP309 and JP310 "open". GND: JP308 "open" JP309 and JP310 "short"
11*	Ext. trigger	NC: JP401 and JP301* "open". +12V DC JP401 "short" and JP301* "open"
12	GND	

Notes:

- *) *Signals on pin no. 6, 7,9,10 and 11 can be changed by jumper setting. See section 8 "Switch Settings" and section 9 "Jumper Settings" for more information.*
- *) *In Edge Pre-select and Pulse Width Control mode do not input ext. VD signal.*
- *) *When using the HD/VD, PCLK and WEN signals (input or output) from the 12-pin connector do not use the same signals (input or output) from the 9 pin D-SUB connector.*
- *) *JP301 is "short" by a capacitor (factory setting – see section 9 "Jumper Settings").*
- *) *Signals shown in bold italics are factory settings.*

5.2 6-pin Multi-connector (RS 232C/TRIGGER)

Type: HR10A-7R-6PB (Hirose male)
Seen from rear.

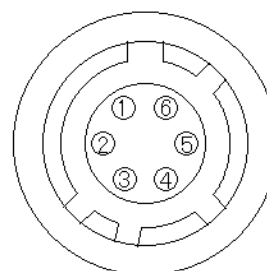

Pin No.	5.2.1.1 Signal	5.2.1.2 Remarks
1	TXD (RS-232C)	
2	RXD (RS-232C)	
3	GND	
4*	NC	GND: JP402 "short"
5	Ext.TRIG input	
6*	EEN output	WEN out: JP312 "open" and JP311 "short"

Notes:

- *) *Signals on pin no. 4 and 6 can be changed by jumper setting.*

- *) See section 8 “Switch Settings” and section 9 “Jumper Settings ” for more information.
 When using the WEN signal from the 6 pin connector do not use the same signal from the 9 pin connector.
- *) Signals shown in bold italics are factory settings.

5.3 9-pin DSUB-connector (RGB/SYNC.)

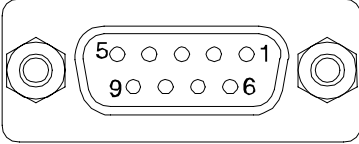

Pin No.	5.3.1.1 Signal	5.3.1.2 Remarks
1*	NC	VD input: JP303 “open” and JP304 “short”
2	GND	
3	R output	
4*	G output	Sync. on G: SW302-3 “ON”
5	B output	
6*	HD input	HDinput: SW303-1 “ON”. HDout: SW303-1 “OFF”
7*	Sync output	WEN output: SW302-4 “ON”
8	GND	
9*	NC	PCLK output: JP305 “open” and JP306 “short”

Notes:

- *) Signals on pin no. 1,4, 6,7 and 9 can be changed by jumper setting.
 See section 8 “Switch Settings” and section 9 “Jumper Settings ” for more information.
- *) In Edge Pre-select and Pulse Width Control mode do not input ext. VD signal.
- *) When using the HD/VD, PCLK and WEN signals (input or output) from the 9-pin D-SUB connector do not use the same signals (input or output) from the 12 pin or 6 pin connectors.
- *) Signals shown in bold italics are factory settings.

5.4 Input and Output Circuits

In the following schematic diagrams the input and output circuits for video and timing signals are shown. For alternative connections refer to “Internal Switch and Jumper Settings”. Jumper settings are shown as for factory default.

5.4.1 Video input

The video output signal is a 75Ω RGB video signal. The signal level is 0.7Vpp. Composite sync. is selectable on the green video signal via software or the internal switch 302-3. The sync. signal level is 0.3Vpp.

5.4.2 Trigger input

The trigger input is AC coupled with a flip-flop. The input signal level is $4V \pm 2V$. The trigger input impedance is 1.2 kΩ or 75Ω selectable via the internal switch S301-3.

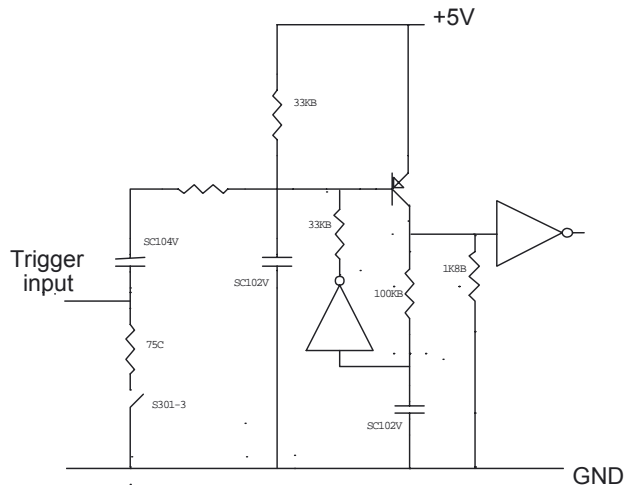

5.4.3 HD and VD input

The HD and VD input circuit can be 75Ω terminated via the internal switch S301-1 and S301-2. The input signal level is $4V \pm 2V$.

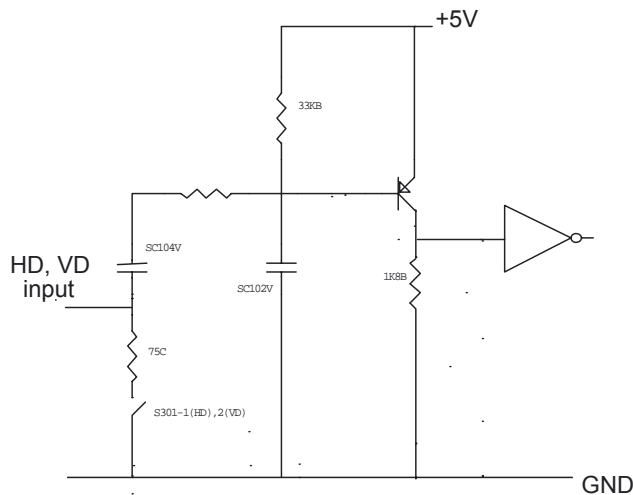

5.4.4 HD, VD, PCLK, WEN and EEN output

The output circuits for these signals are 75Ω complementary emitter followers. The single circuit delivers a TTL signal. The output level $\geq 4V$ from 75Ω (no termination).

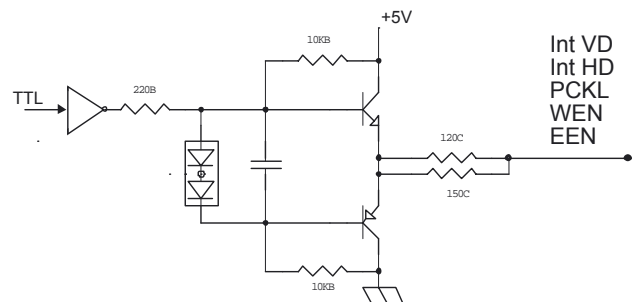

6 Functions and Operation

Apart from the standard continuous operation, the CV-M77 features three external triggering modes, Edge Pre-select, Pulse Width Control mode and Readout Delay mode. These 3 external triggering modes operate with H non-reset. In H non-reset, the exposure will be synchronized to the internal HD and the exposure will start at the first HD after the negative going edge of the trigger (see figure 6-1).

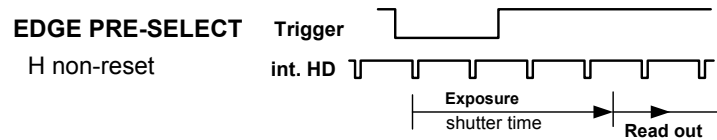

Figure 6-1: H non-reset relation

6.1 Input/Output of HD/VD Signal

6.1.1 Input of External HD/VD signals

This setting is factory pre-set. The video output is synchronized with external HD/VD signals if applied. If no ext. HD signal is input the camera will switch to the internal X-tal controlled HD sync. If no ext. VD is connected the camera will continue with its internal VD. The external HD/VD signal is factory preset to TTL signals (2.0-5.0V). The external HD/VD signals can be 75 ohm terminated by setting the S301-1,2 switches on the PK 8308 board to ON (see switch settings) – the signal input level is then 4.0 Vp-p \pm 2.0V.

6.1.2 Output of Internal HD/VD signals

In order to output internal HD/VD signals the S303-1,2 switches on the PK 8308 board have to be set to OFF. The output can be either TTL level or from a 75 Ω source by setting the proper S301 switches on the PK 8308 board to OFF or ON (see switch settings).

6.2 Continuous operation

For applications that do not require asynchronous external trigger but run in continuous operation this mode is used. On the camera rear panel SW1-5 to SW1-7 are set to OFF for normal internal trigger mode. The shutter time (the exposure time) is selected by SW1-1 to SW1-4. The mode setting and the shutter setting can be done via RS 232C control.

6.3 External Trigger Mode

The CV-M77 camera features 3 external triggering modes:

- 1 Edge Pre-select mode. (Asynchronous reset and exposure start by an ext. trigger pulse)
- 2 Pulse Width Control mode. (Exposure control by the low period of the ext. trigger pulse)
- 3 Readout Delay mode. (The readout is controlled by the ext. trigger and an ext. VD signal)

For all three triggering modes the exposure will start at the next internal HD as explained above (H non-reset). The trigger input can be TTL level or 75 ohm terminated by setting the specific S301 switch on the PK 8308 board to OFF or ON (see switch settings). When 75 ohm terminated the signal input level is 4.0 Vp-p \pm 2.0V.

6.3.1 Edge Pre-select Trigger Mode

This trigger mode operates in H non-reset mode. In H non-reset mode the exposure will start at the first internal HD after the trigger. The trigger input should be longer than or equal to 2 HD (102 μ sec.) and shorter than 1msec. The external trigger pulse initiates the capture, and the exposure

time (accumulation time) is governed by the fixed shutter speed set up by the rear panel DIP-switches or via RS-232C control. The resulting video signal will start to be read out after the selected shutter time. The WEN pulse indicates the start of valid video signal. Refer to timing charts for details. A new trigger pulse must not be applied before the video read out has finished. If the camera is synchronized to an external HD signal, there are some requirements to the phase between the ext. HD and the Ext. trigger. The falling edge of the trigger should be less than 8 μsec before the falling edge of the ext. HD and less than 2 μsec after the falling edge of the ext. HD (see figure 6-2). Otherwise the jitter will be too high.

To use this mode:

Set SW1-5,6 and to SW1-7 on the rear plate of the camera to "OFF" or use the RS 232C control.

CV-M77 Input Signal Phase Relation

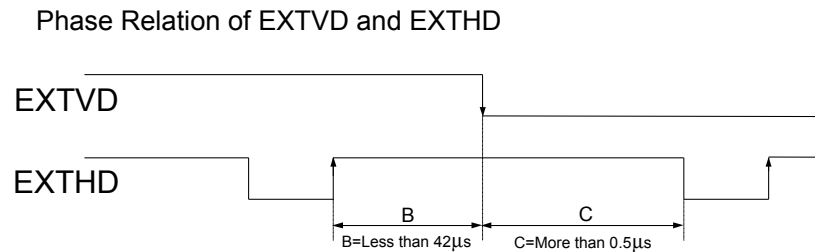
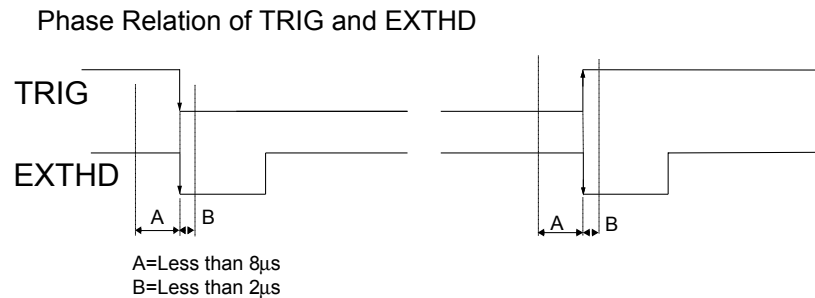

Figure 6-2: Input signal phase relation

6.3.2 Pulse Width Control Trigger Mode

This trigger mode where the length of the trigger pulse determines the exposure time operates in H non-reset mode. In H non-reset mode the trigger pulse and the HD signal are synchronized. The exposure will start at the first HD pulse after the falling edge of the external trigger signal. The exposure ends at the rising edge of the external trigger signal. The trigger pulse must be longer than $>1\text{H}$ (51 μsec) and shorter than 2000 H. To avoid jitter the camera should be synchronized to an external HD. There are some requirements to the phase between the ext. HD and the Ext. trigger. The falling edge of the trigger should appear in the interval less than 8 μsec before the falling edge of the ext. HD and less than 2 μsec after the falling edge of the ext. HD and the rising edge off the trigger should be fall in the interval 8 μsec before the rising edge of the ext. HD and 2 μsec after rising edge of the ext. HD. (See figure 6-2).

The resulting video signal will start to be read out after the rising edge of the external trigger signal. The WEN pulse indicates the start of valid video signal. Refer to timing charts for details.

A new trigger pulse must not be applied before the video read out has finished.

To use this mode:

Set SW1-5 and SW1-6 on the rear plate of the camera to "ON" and SW1-7 to OFF or use the RS 232C control to set-up the PWC mode of the camera.

6.3.3 Frame-delay Readout Mode

This trigger mode operates in H non-reset mode. In H non-reset mode the trigger and HD is synchronized. The exposure will start at the first HD pulse after the falling edge of the external trigger signal. The exposure ends at the rising edge of the external trigger signal. The trigger pulse must be longer than $>1H$. To avoid jitter, the camera should be synchronized to an external HD. There are some requirements to the phase between the ext. HD and the Ext. trigger. The falling and rising edge off the trigger should be within $8\ \mu\text{sec}$. before the falling and rising edge of the ext. HD pulse and not later than $2\ \mu\text{sec}$ after the falling and rising edge of the HD pulse (see fig. 6.3) The resulting video signal will first start to be read out after the input of an external VD signal. The readout delay should not be too long due to visible dark current noise generated in the CCD sensor. The WEN pulse indicates the start of valid video signal. Refer to timing charts for details. A new trigger pulse must not be applied before the video read out has finished.

To use this mode:

Set SW1-5 to SW1-7 on the rear plate of the camera to "ON" or use the RS 232C control to set-up the Frame-delay Readout Mode of the camera.

6.3.4 Long Time Exposure Mode

The exposure time is the interval between 2 ext. VD pulses sent to the VD input of the camera. The exposure starts after input of the first ext. VD pulse, and ends after the next input of the ext. VD pulse, which again starts a new exposure.

The long time exposure is a continuous process where each external VD pulse will synchronize the camera, stop on exposure, start a new exposure and read out the previous accumulated signal. The exposure can be selected in intervals of complete vertical timing periods ($=792H$)

This long time exposure mode operates in H non-reset mode. In H non-reset mode the external VD signal and the internal HD signal are synchronized. The exposure will start at the first HD pulse after the falling edge of the external trigger signal. See figure 6-2 for the phase relationship between ext. HD and ext. VD pulses.

To use this mode:

Set SW1-1 to SW1-7 on the rear plate of the camera to OFF or use the RS 232C control. Apply the continuous external VD signal.

6.4 Timing diagram for Horizontal and Vertical Sync. Video Output

CV-M77 Timing Chart of Horizontal Sync. Video Output

1ck ≐ 40ns

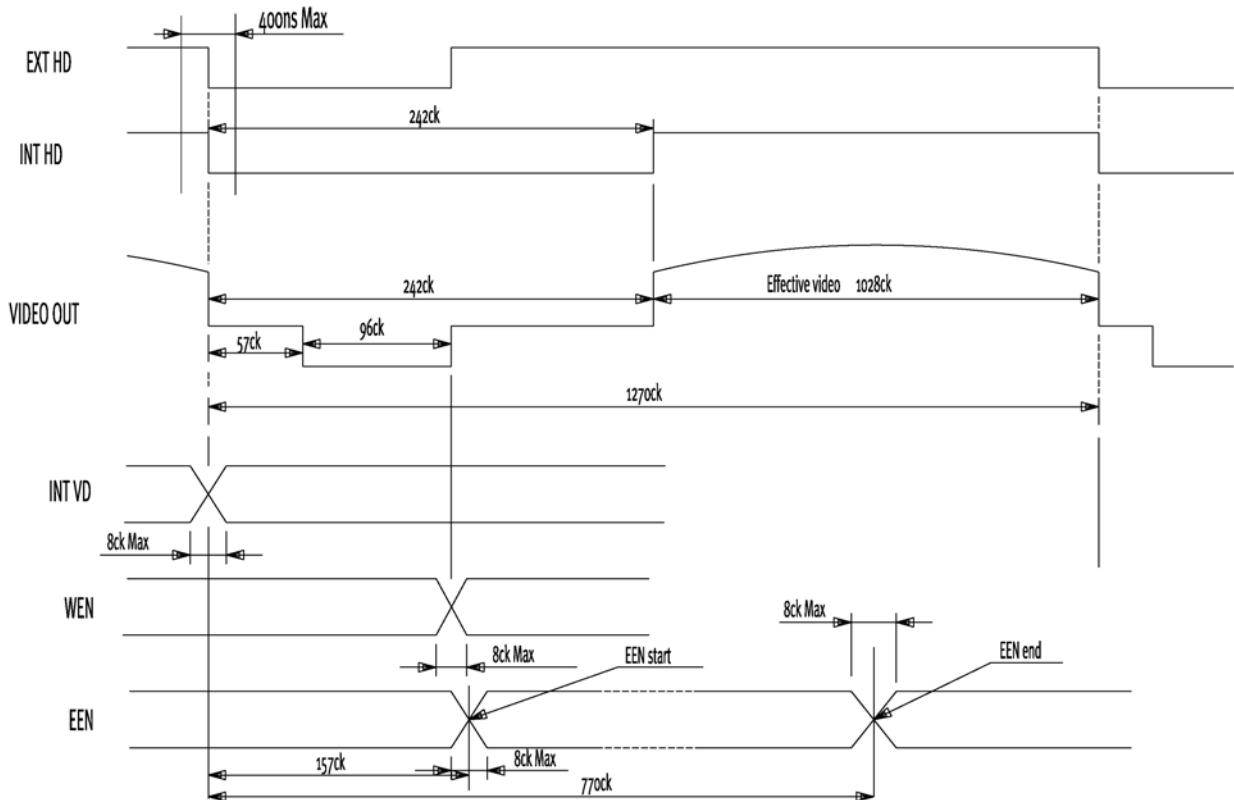

CV-M77 Timing Chart of Vertical Sync. Video Output

1H = 50.8 μs

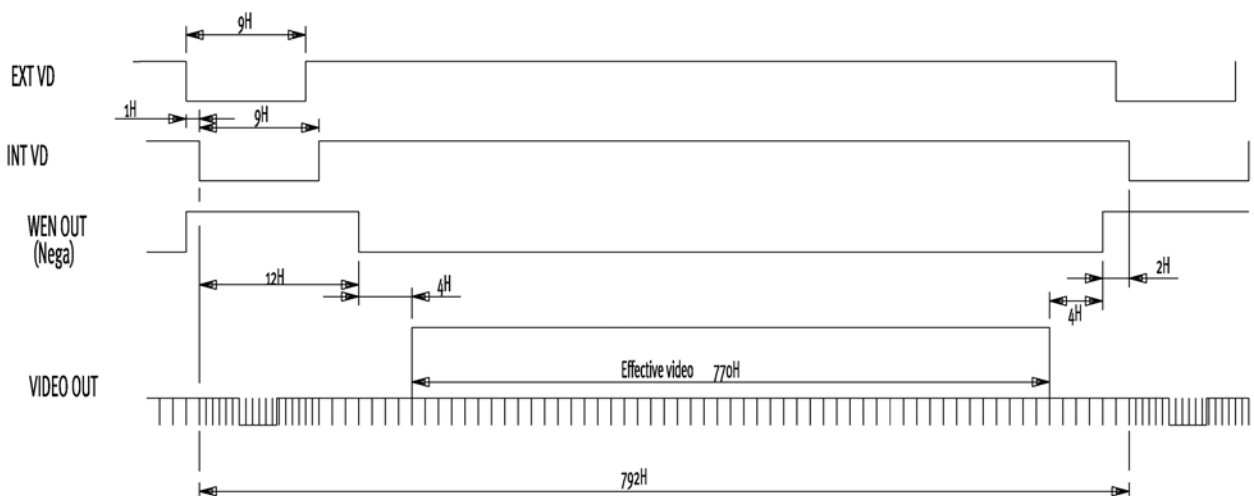

6.5 Timing diagram for Edge Pre-select mode

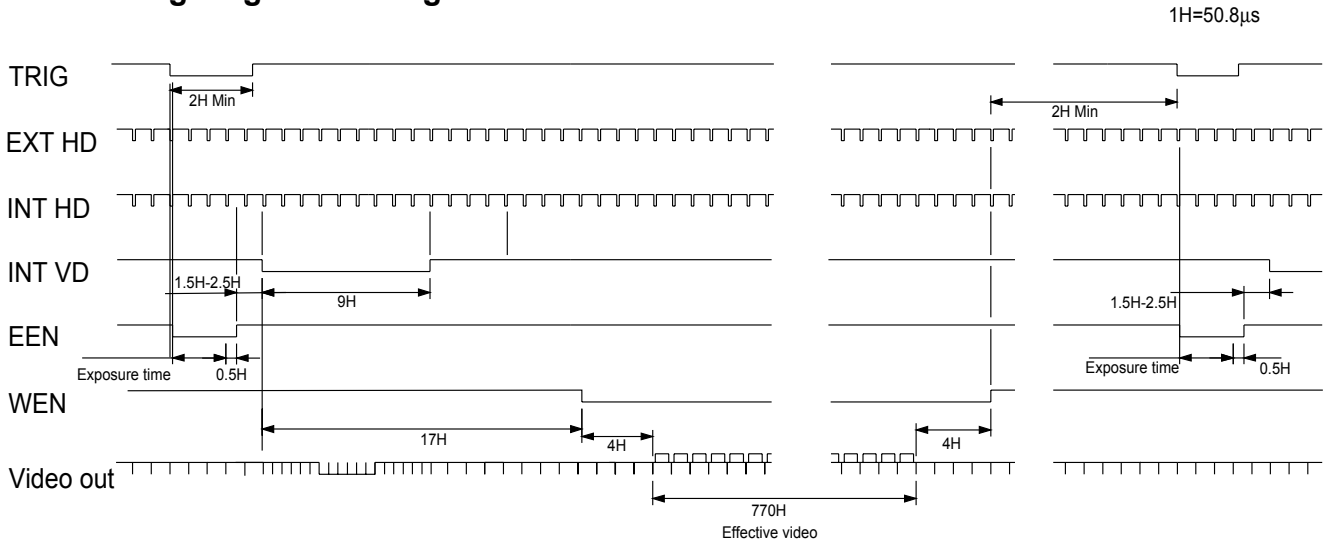

6.6 Timing diagram for Pulse Width Control mode

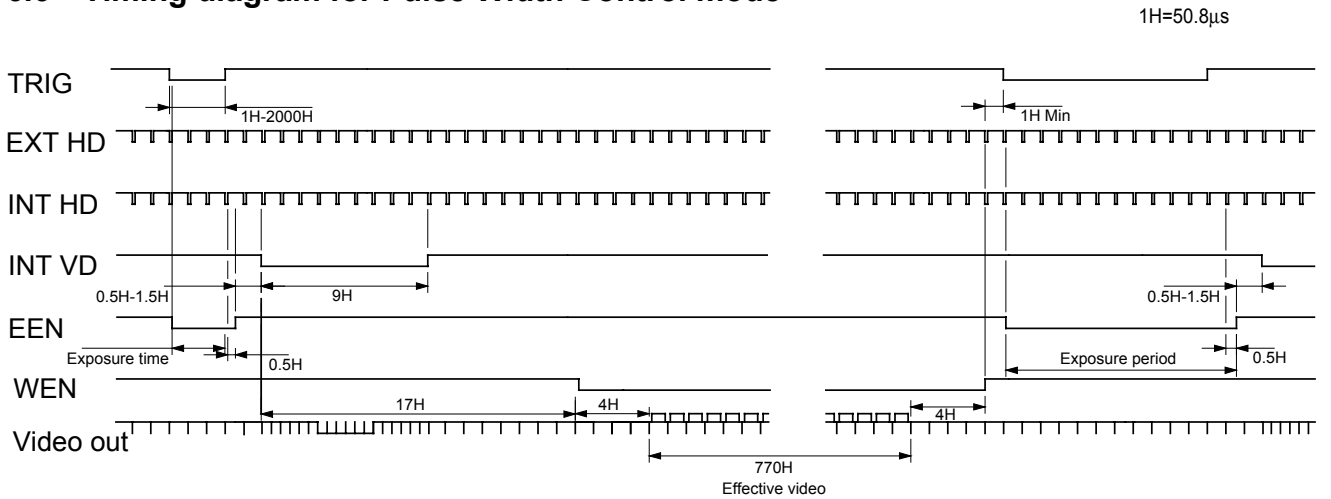

6.7 Timing diagram for Frame-delay Readout mode

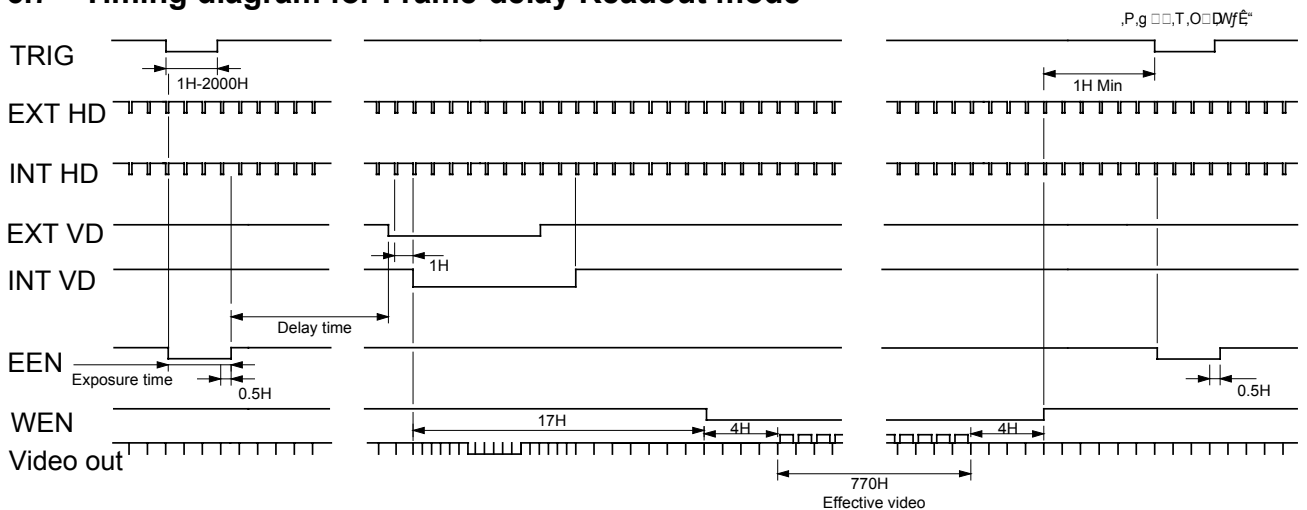

6.8 Timing diagram for Long Time Exposure mode

1H=50.8μs

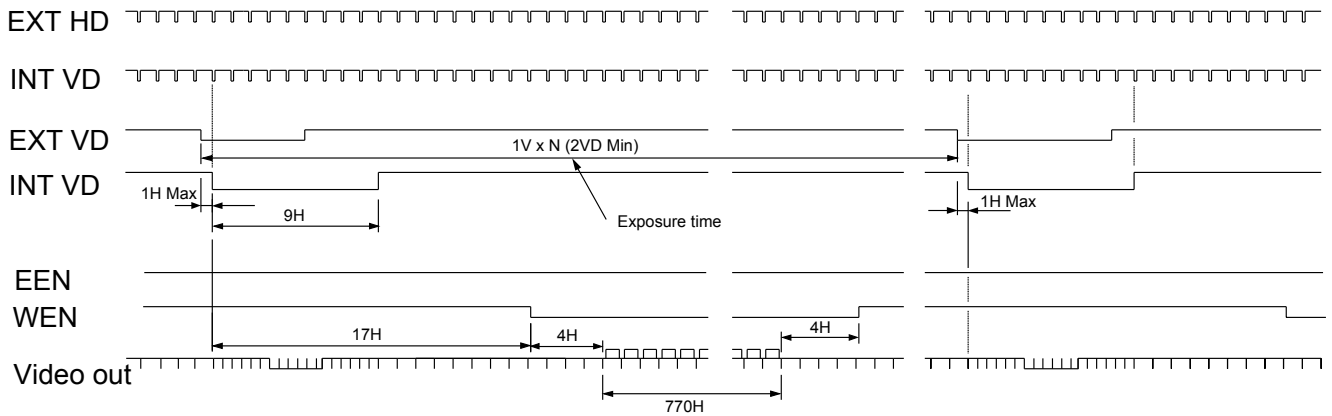

Remarks:
 1VD indicates 792H.
 The interval of EXT VD input has to be multiple number of 1VD.
 EEN is low

7 Configuring the camera using the serial interface.

7.1 Mode Setting using ASCII commands via the RS-232C port.

The configuration of the CV-M77 camera can be done via the RS-232C port. The camera is to be set up via an ASCII terminal or from a PC running terminal emulator software. Below is the description of the ASCII based short command protocol.

The RS-232C serial interface specification for CV-M77 is:

7.2 Communication setting

Baud Rate	9600bps
Data Length	8bit
Stop Bit	1bit
Parity	Non
Xon/Xoff Control	Non

7.3 Command Protocol

	Command Name	Format	Parameter	Remarks
A - General settings and useful commands.				
1	Echo back	EB=[Param.]<CR><LF>	0=Echo off 1=Echo on Set to 'off' when power is on.	
2	Firmware program version request	VN?<CR><LF>		Response is 3 letter (ex) 100
B - Timing and shutter related commands.				
1	Shutter mode	SM=[Param.]<CR><LF> SM?<CR><LF>	0=Normal 1=Programmable exposure	
2	Shutter speed	SH=[Param.]<CR><LF> SH?<CR><LF>	0=OFF(1/25), 1=1/50, 2=1/125, 3=1/250, 4=1/500, 5=1/750, 6=1/1000, 7=1/1500, 8=1/2000, 9=1/3000, 10=1/4000, 11=1/10000	Available when SM=0 and TR=0 or 1 or 3.
3	Programmable exposure	PE=[Param.]<CR><LF> PE?<CR><LF>	3-791 (1/10000s - 1/25s in 1HD increments) 3= 1.5H(0.076ms) 4= 2.5H(0.127ms) : 791=789.5H(40.107ms)	Available when SM=1 and TR=0 or 1 or 3.
4	Trigger mode	TR=[Param.]<CR><LF> TR?<CR><LF>	0=Normal 1=Edge pre-select 2=Pulse width control 3=Frame delay readout 4=Long time shutter 5=PWC delay readout	
5	Wen polarity	WP=[Param.]<CR><LF> WP?<CR><LF>	0=Active_L, 1=Active_H	
6	G on SYNC	SY=[Param.]<CR><LF> SY?<CR><LF>	0=OFF, 1=ON	
7	EEN polarity	EP=[Param.]<CR><LF> EP?<CR><LF>	0=Active_L, 1=Active_H	
8	WEN/Sync switch	WS=[Param.]<CR><LF> WS?<CR><LF>	0=WEN, 1=Sync	

C - Gain and analogue signals settings.			
1	AGC switch	AS=[Param.]<CR><LF> AS?<CR><LF>	0=OFF (Manual), 1=ON (Auto)
2	Master gain level	GA=[Param.]<CR><LF> GA?<CR><LF>	0-700 Available when AS=0.
3	Red gain level	RG=[Param.]<CR><LF> RG?<CR><LF>	0-255 Available when WB=0.
4	Blue gain level	BG=[Param.]<CR><LF> BG?<CR><LF>	0-255 Available when WB=0.
5	AGC level	AG=[Param.]<CR><LF> AG?<CR><LF>	0-255 Available when AS=1.
6	White balance	WB=[Param.]<CR><LF> WB?<CR><LF>	0=Manual (Variable) 1=Auto (Variable) 2=4600K (Fixed) 3=5600K (Fixed) Sets manual gain values (RG, BG) when changed to 0 from other selections.
7	Auto white balance	AW=[Param.]<CR><LF>	0=One push auto white balance Available when WB=1.
8	Master setup level	SU=[Param.]<CR><LF> SU?<CR><LF>	33-223 (default = 128)
9	Red setup level	RS=[Param.]<CR><LF> RS?<CR><LF>	96-160 (default = 128)
10	Blue setup level	BS=[Param.]<CR><LF> BS?<CR><LF>	96-160 (default = 128)
11	White clip level	WC=[Param.]<CR><LF> WC?<CR><LF>	0-1023
12	Gamma select	GS=[Param.]<CR><LF> GS?<CR><LF>	0=1, 1=0.45, 2=0.6

D - saving and loading data in EEPROM			
1	Load settings (from camera EEPROM)	LD=[Param.]<CR><LF>	0=FACTORY DATA AREA 1=USER DATA AREA Latest used DATA AREA becomes default at next power up.
2	Save settings (to camera EEPROM)	SA=[Param.]<CR><LF>	1=USER DATA AREA
3	Save settings into Factory Area.	SA00=[Param.]<CR><LF>	0=FACTORY DATA AREA Not disclosed for user.
4	EEPROM Current Area No. Request	EA?<CR><LF>	0=FACTORY DATA AREA 1=USER DATA AREA

7.3.1 Receiving Data (Camera->PC)

If the function succeeds, the return value is a handle to the newly allocated memory object. If the setting succeeds, returned is the below word from the camera.

COMPLETE<CR><LF>

Error Messages:

- Command Error:
01 Unknown Command!!<CR><LF>
- Parameter Error:
02 Bad Parameters!!<CR><LF>

Response to Request Command

Example:

Request Command (PC->Camera)		Receiving Data(Camera->PC)	Remarks
Command Name	Format		
Trigger Mode	TR?<CR><LF>	TR=[Param.]<CR><LF>	"Param." is same as setting command.

Response to firmware version request command

Example:

Request Command (PC→Camera)		Receiving Data(Camera→PC)	Remarks
Command Name	Format		
Version Request	VN?<CR><LF>	***<CR><LF>	*** is Version No. (3 letter)

7.4 RS232C Cable Connections

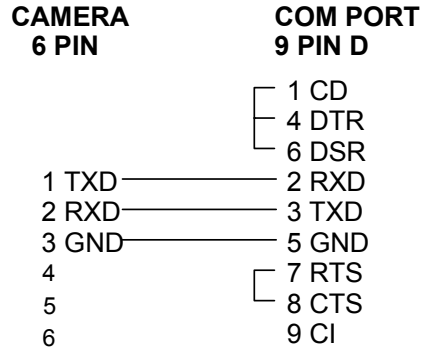

8 Switch Settings

Before changing any switch settings or jumper settings turn off the power.

8.1 Mode Settings by Switch

The factory setting for the SW-1 switch on the rear panel of the camera is OFF: The electronic shutter is OFF, the external trigger modes are OFF, gamma is OFF (=1.0), the AGC is OFF and the RS-232C control is disabled.

		SW 1														
		OFF (<)	ON (>)													
				OFF (1/25)	1/50	1/125	1/250	1/500	1/750	1/1000	1/1500	1/2000	1/3000	1/4000	1/10000	
Shutter		1		^	^	^	^	^	^	^	^	^	^	^	^	
Shutter		2		^	^	^	^	v	v	v	v	v	v	v	v	
Shutter		3		^	^	v	v	^	^	^	^	^	^	^	^	
Shutter		4		^	v	^	v	^	v	^	v	^	v	^	v	
Ext.trigger		5		^	v	v	v	^	^	^	^	^	^	^	^	
Ext.trigger		6		^	^	v	v	^	^	Edge Pre- Select	^	^	^	^	^	
Frame delay		7		^	^	^	v	^	^	Normal	^	^	^	^	^	
Gamma		8		1.0		^	v	0.45		^	^	^	^	^	^	
Gain		9		Manual		^	v	Auto		^	^	^	^	^	^	
Control		10		Local		^	v	RS 232C		^	^	^	^	^	^	
												Pulse Width Control				
													Read- out Delay			

Figure 8-1: Rear plate switch settings

8.2 Signals by Switch Settings

On the PK8308 board inside the camera three switches exist. The switch settings determine

- Termination of external trigger, VD and HD signals
- Color temperature
- Composite sync. on green video signal
- WEN OFF/ON at DSUB connector
- Input/Output of VD and HD signals

8.2.1 SW301 switch

		S301	
		TTL	75Ω
		OFF	ON
HD:	1		
VD:	2		
TRIG:	3		
NC:	4		

The SW301 switches (1-3) in "ON" position activates 75Ω termination of ext.HD and ext.VD signals and it activates 75Ω termination of an ext.trigger signal. The factory setting is "OFF" enabling TTL signal termination for all three signals.

8.2.2 SW302 switch

S302

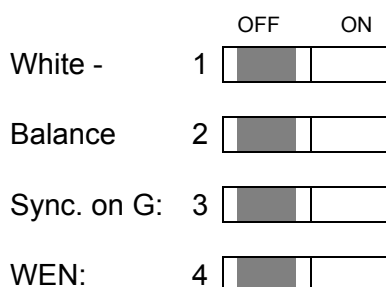

The SW302 switch has the following functions: The switches (1-2) determines the color temperature, the switch (3) activates Composite sync. on the green video signal and the switch (4) outputs the WEN signal at the DSUB connector.

The white balance is dependent on the color temperature of the light. The available settings are:

S302-1	S302-2	Color temperature
OFF	OFF	2800-5600K (factory setting)
OFF	ON	Invalid setting
ON	OFF	4600K
ON	ON	5600K

The S302-3 switch adds in "ON" position the composite sync. signal to the green video signal. The factory setting is "OFF" leaving the green RGB signal without sync. signals.

The S302-4 switch outputs in "ON" position the WEN signal via pin 7 of the 9-pin DSUB connector. The factory setting is "OFF". In the "OFF" position the camera outputs the composite sync. signal via pin 7 of the 9-pin DSUB connector.

8.2.3 SW303 switch

S303

output ↔ input

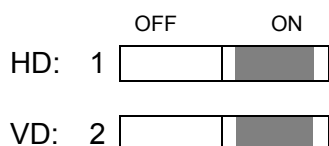

The SW303 switch switches between output of internal HD/VD signals and input of external HD/VD signals. The factory setting is input of external HD/VD signals (SW303-1 and SW303-2 in "ON" position). The "ON" position is towards switch SW301.

9 Jumper settings

Before changing any switch settings or jumper settings turn off the power.

9.1 Jumper locations

The jumpers are located on two boards, the PK8309A board and the PK8308A board:

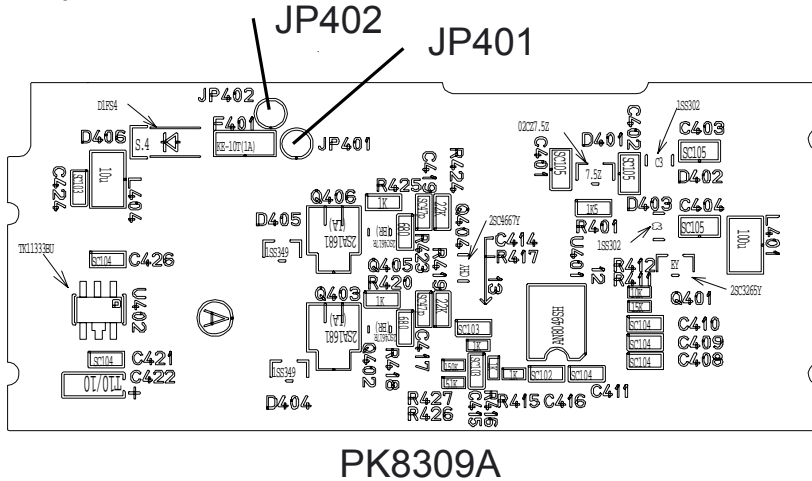

The PK8309A board have two jumpers of interest: JP401 and JP402. Factory setting:

- JP401 and JP402 are “open”.

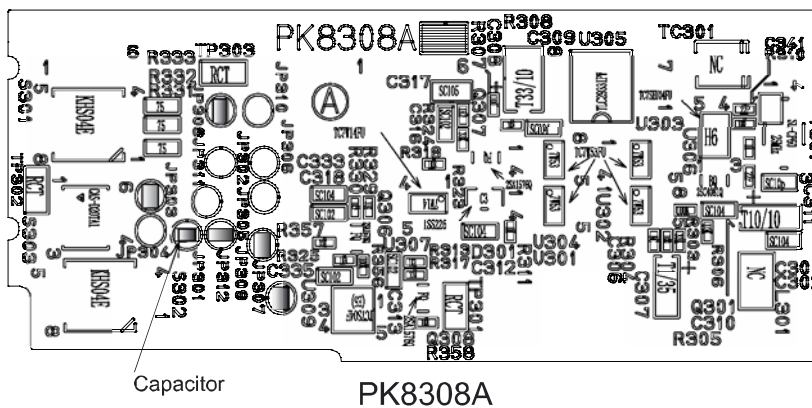

The PK8308A board has 12 jumpers of interest: JP301-JP312. Factory setting:

- At JP301 is mounted a capacitor to protect the trigger circuit against +12V DC.
- JP303, JP307, JP308, JP309 and JP312 are “short”.
- JP302, JP304, JP305, JP306, JP310 and JP311 are “open”.

9.2 Jumper table

Jumper settings versus connector pin configuration.

Pin#	Function	JP301	JP302	JP303	JP304	JP305	JP306	JP307	JP308	JP309	JP310	JP311	JP312	JP401	JP402
12-pin Hirose connector															
6	Ext. HD input							Short							
6	Int. HD output							Short							
7	Ext. VD input		Open	Short	Open										
7	Ext. VD output		Open	Short											
9	NC					Open									
9	PCLK output					Short	Open								
10	WEN		Open						Short	Short	Open				
10	NC									Open	Open				
10	GND								Open	Short	Short				
11	Trigger														
11	NC		Capacitor											Open	
11 *)	+12V DC		Open											Short	
6-pin Hirose connector															
4	NC														Open
4	GND														Short
6	WEN		Open									Short	Open		
6	EEN											Open	Short		
9-pin DSUB connector															
1	NC														
1	VD input		Open	Open		Open									
6	HD input							Open							
6	HD output							Open							
9	NC													Open	
9	PCLK output													Short	

NOTE: When using the HD/VD, PCLK and WEN signals (input or output) from the 12 pin connector do not use the same signals (input or output) from the 9 pin D-SUB connector and vice versa.

*) The external trigger pulse or DC +12V can be input at pin No.11 of the 12 pin Hirose connector by changing the jumper setting on PK8308 and PK8309. A capacitor is mounted at jumper JP301 to avoid feeding the trigger circuit with +12V DC. If this capacitor is removed from JP301 for some reason make sure JP301 is open before feeding the camera with +12V DC at pin No.11 of the 12 pin Hirose connector.

*) Greyed out jumper settings are factory settings.

10 CV-M77 Camera Control Tool

The Camera Control Tool software for the CV-M77 camera is available from the JAI homepage (www.jai.com). The software runs under Windows 98, NT and Windows 2000.

The software interface has incorporated all the commands described in the ASCII protocol in an easy to use fashion – more user-friendly for some than the HyperTerminal or similar programs.

From www.jai.com Camera Control Tool software for windows 98/NT/2000 can be downloaded. Below the different windows are shown.

Control Bar



Windows for all functions

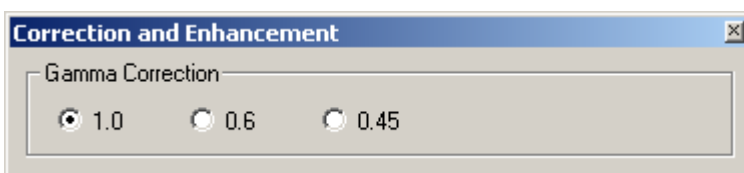
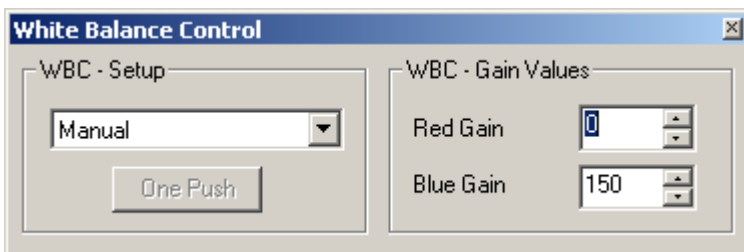
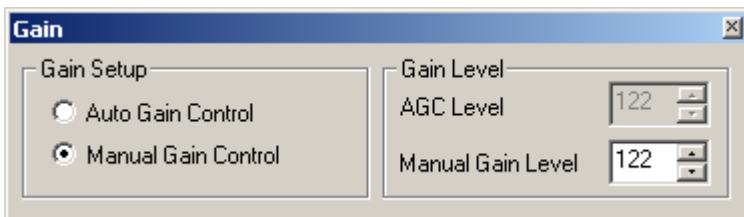
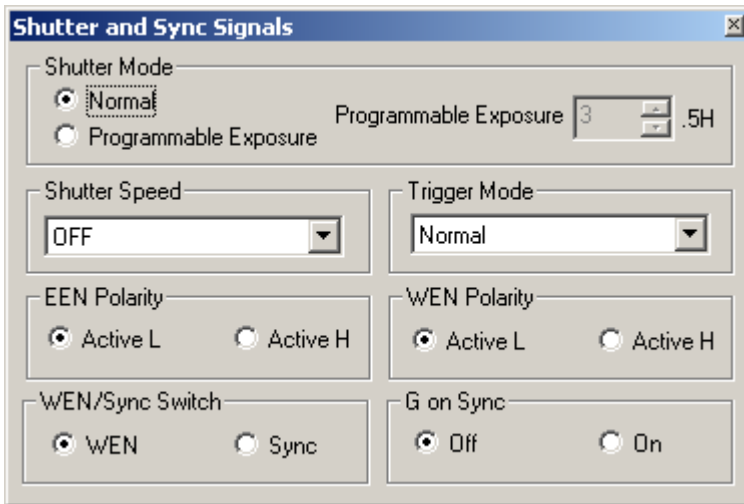

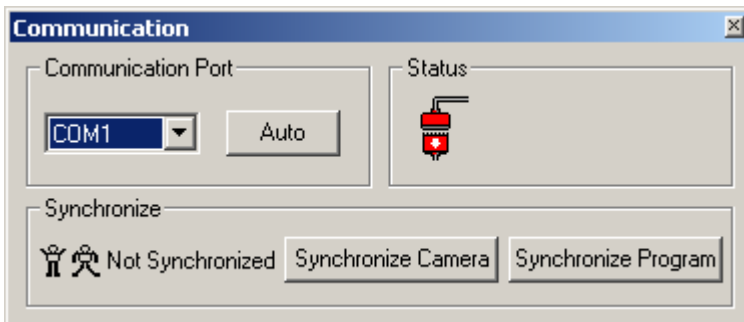
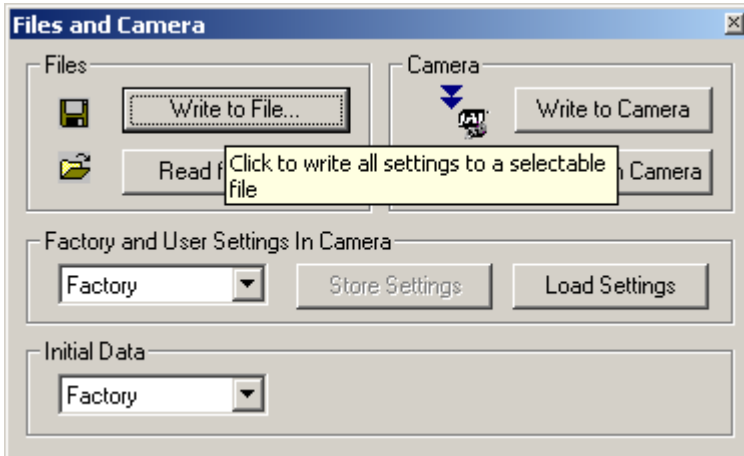
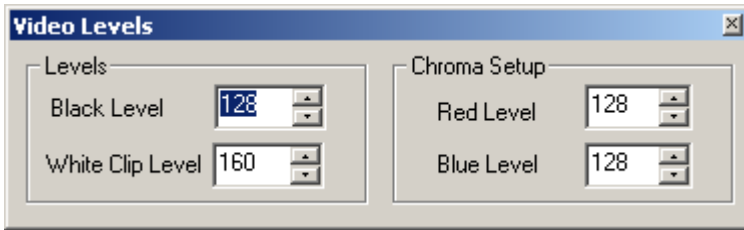

Fig. Windows from the Camera Control Tools software.

11 Specifications

Scanning system	Progressive 792 lines 24.8 frames/sec.
Pixel clock	25.000 MHz
Line frequency	19.685 kHz (1270 pixel clock/line)
Frame rate	24.8 frames/sec. (792 lines/frame)
CCD sensor	1/3" RGB primary color IT CCD
Sensing area	4.8 (h) x 3.6 (v) mm
Effective pixels	1034 (h) x 779 (v)
Pixels in video output	1028 (h) x 770 (v)
Cell size	4.65 (h) x 4.65 (v) μ m
Sensitivity on sensor	1.5 Lux (Max. gain, 50% video)
S/N ratio	>50 dB
Video output	RGB video signal, 0.7 Vpp, 75 Ω Composite sync. on G, 0.3 Vpp (selectable)
Gamma	1.0 – 0.6 – 0.45
Gain	Manual – Automatic
Gain range	-3 to +15 dB
Synchronization	Int. X-tal. Ext. HD/VD or random trigger
HD sync. input/output	4 V \pm 2 V, 75 Ω
Trigger input	4 V \pm 2 V, 75 Ω
WEN output (write enable)	4 V \pm 2 V, 75 Ω
EEN output (exposure enable)	4 V \pm 2 V, 75 Ω
Pixel clock output	4 V \pm 2 V, 75 Ω
Composite sync. output	4 V \pm 2 V, 75 Ω
Trigger modes	Continuous, Edge pre-select, Pulse width control (HD non-reset)
Trigger input. (Edge pre-select)	>1 H
Shutter	1/25, 1/50, 1/125, 1/250, 1/500, 1/750, 1/1000, 1/1500, 1/2000, 1/3000, 1/4000, 1/10,000 second
Programmable exposure	1.5 H to 791 H
Pulse width control	1.5 H to 2000 H
Long time exposure	2 frames to ∞
Frame-delay readout	1 H to 2000 H Time from trigger input to ext. VD input. For Edge pre-select and Pulse width control
Functions controlled by DIP switch on rear	Shutter speed, Trigger mode, Readout mode, Gamma, Gain, Control
Functions controlled by internal DIP switches	VD input/output, HD input/output HD, VD and Trigger 75 Ω termination on/off WEN polarity, Sync. on G, White balance
Functions controlled by RS 232C	Shutter speed, Trigger mode, Readout mode, WEN polarity, Sync on G, Programmable exposure, Gain levels, White clip, Setup, Gamma, White balance
Communication Baud rate	9600 bps
Operating temperature	-5°C to +45°C
Humidity	20 - 80% non-condensing
Storage temp./humidity	-25°C to +60°C / 20% - 80 %
Power	12V DC \pm 10%, 5.5 W
Lens mount	C-mount
Dimensions	40 x 50 x 90 mm (H x W x D)
Weight	270 g

Note: Above specifications are subject to change without notice.

11.1 Spectral sensitivity

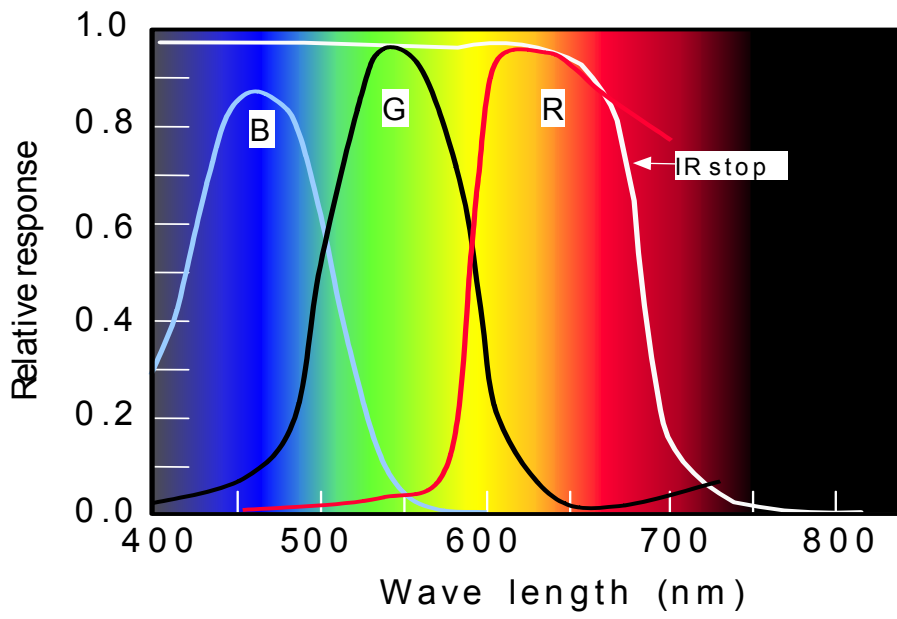

12 Appendix

12.1 Precautions

Personnel not trained in dealing with similar electronic devices should not service this camera.

The camera contains components sensitive to electrostatic discharge. The handling of these devices should follow the requirements of electrostatic sensitive components.

Do not attempt to disassemble this camera.

Do not expose this camera to rain or moisture.

Do not face this camera towards the sun, extreme bright light or light reflecting objects. When this camera is not in use, put the supplied lens cap on the lens mount.

Handle this camera with the maximum care.

Operate this camera only from the type of power source indicated on the camera.

Power off the camera before any modification such as changes of jumper and switch settings are performed.

12.2 Typical CCD Characteristics

The following effects may be observed on images acquired by CCD cameras. They do not indicate any fault of the CCD camera function, but associate with typical CCD sensor characteristics.

12.2.1 Smear

Due to an excessive bright object such as car lights, the sun or strong reflection, vertical smear may be visible. This phenomenon is related to the characteristics of the Interline Transfer System employed in the CCD.

12.2.2 Aliasing

When the CCD camera captures stripes, straight lines or similar sharp patterns, jagged images may appear.

12.2.3 Blemishes

12.2.3.1.1.1.1 Some pixel defects can occur. This does in general not have an effect on the practical operation.

12.2.4 Patterned Noise

When the CCD camera captures a dark object at high temperature or is used for long time integration, fixed pattern noise (shown as bright dots) may appear on the image.

12.3 References

1. This manual and the datasheet for the CV-M77 camera can be downloaded from www.jai.com
2. Camera control software is available from www.jai.com
3. Specifications for the ICX204AK CCD sensor can be found via www.jai.com

13 Users Record

Camera type: CV-M77
Revision: (Revision A)
Serial No.

Users Mode Settings

Users Modifications

14 Index

No index.

Free Manuals Download Website

<http://myh66.com>

<http://usermanuals.us>

<http://www.somanuals.com>

<http://www.4manuals.cc>

<http://www.manual-lib.com>

<http://www.404manual.com>

<http://www.luxmanual.com>

<http://aubethermostatmanual.com>

Golf course search by state

<http://golfingnear.com>

Email search by domain

<http://emailbydomain.com>

Auto manuals search

<http://auto.somanuals.com>

TV manuals search

<http://tv.somanuals.com>