

Distributed by:

**JAMECO**<sup>®</sup>  
ELECTRONICS

**www.Jameco.com ♦ 1-800-831-4242**

The content and copyrights of the attached  
material are the property of its owner.

Jameco Part Number 2075815

Download from [www.Somanuals.com](http://www.Somanuals.com). All Manuals Search And Download.

USB 2.0 to SATA/IDE Combo Adapter

# **User's Manual**

## **Safety Instructions**

Always read the safety instructions carefully

- Keep this User's Manual for future reference
- Keep this equipment away from humidity
- If any of the following situation arises, get the equipment checked by a service technician:
  - The equipment has been exposed to moisture.
  - The equipment has been dropped and damaged.
  - The equipment has obvious sign of breakage.
  - The equipment has not been working well or you cannot get it to work according to the User's Manual.

## **Copyright Statement**

No part of this publication may be reproduced in any form by any means without the prior written permission. Other trademarks or brand names mentioned herein are trademarks or registered trademarks of their respective companies.

## **Disclaimer**

Information in this document is subject to change without notice. The manufacturer does not make any representations or warranties (implied or otherwise) regarding the accuracy and completeness of this document and shall in no event be liable for any loss of profit or any commercial damage, including but not limited to special, incidental, consequential, or other damage.

September 2005, Rev1.0

---

# Table of Contents

<b>1. Introduction .....</b>	<b>1</b>
Features .....	1
Package Contents .....	1
System Requirements.....	2
Exterior Overview.....	2
<b>2. Installation and Usage .....</b>	<b>3</b>
Connecting SATA Hard Drive.....	3
Connecting IDE Drive .....	3
Connecting to Computer .....	4
Driver Installation (For Windows 98SE Only) .....	4
Using the Hard drive .....	4
<b>3. Specifications .....</b>	<b>6</b>
<b>4. Regulatory Compliance .....</b>	<b>7</b>
FCC Conditions .....	7
CE .....	7
WEEE Information .....	7

# 1. Introduction

This USB 2.0 to SATA/IDE Combo Adapter allows users to use IDE or SATA (serial ATA) hard drives or both over USB 2.0 connection. Its advantage is that you can keep the existing IDE drive while at the same time move ahead to the new SATA technology, which provides a faster transfer speed of up to 150 Mbps. Both 3.5" IDE (using a converter) and 2.5" IDE are supported. Another great feature is that you can exchange data between SATA and IDE drives by attaching both drives at the same time. Any SATA or IDE drive can be conveniently turned into an external USB 2.0 storage device.

## Features

- Compliant with SATA 1.0a specification
- Compliant with USB 2.0 specification
- Compliant with USB Mass Storage Class Bulk-Only Transport specification
- Dual-Head IDE connector (40Pin and 44Pin) plus one SATA connector; supports 2.5"/3.5"/5.25" IDE and SATA devices (a 2.5" to 3.5" IDE converter is required for 3.5" IDE drive)
- Operates with one IDE and one SATA HDD simultaneously
- External power supply provided
- Supports Plug-and-Play

## Package Contents

Before installation, please check the items of the package.

- |                                     |    |
|-------------------------------------|----|
| ■ USB 2.0 to SATA/IDE Combo Adapter | x1 |
| ■ AC/DC Power Adapter               | x1 |
| ■ AC Power Cord                     | x1 |
| ■ Serial ATA Cable                  | x1 |
| ■ 2.5" to 3.5" IDE Converter        | x1 |
| ■ HDD Power Cable                   | x1 |

## System Requirements

- IBM compatible Pentium-233 MHz or faster PC & MAC with USB support
- Windows® 98SE/ME/2000/XP; Mac OS 8.6 and later

## Exterior Overview

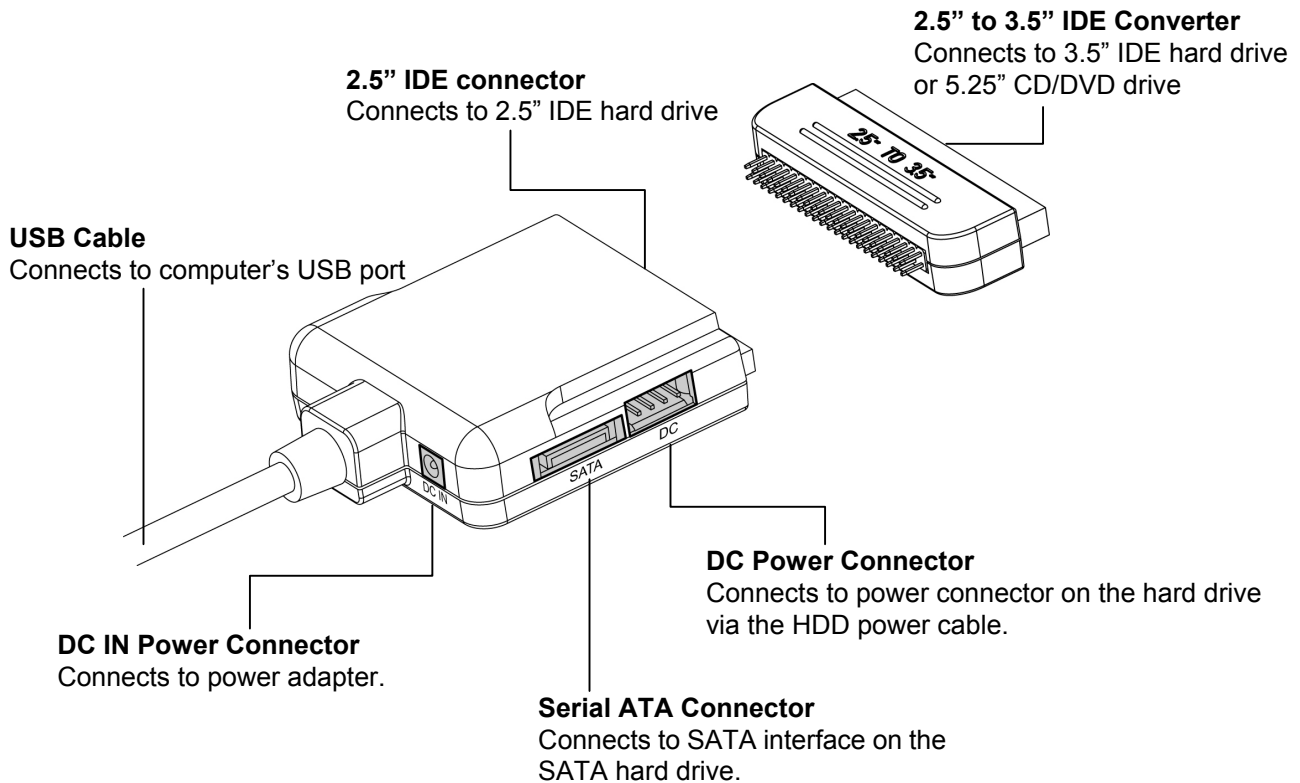

## 2. Installation and Usage

Follow the steps as follows to make the installation. You may connect single IDE and/or SATA (serial ATA) hard drive to the adapter.

### Connecting SATA Hard Drive

1. Connect the provided SATA cable to the SATA receptacle on your SATA hard drive and the adapter.
2. Using the provided HDD power cable, connect the mini 4-pin end to the adapter's **DC** connector and the 15-pin SATA female power connector end to the 15-pin power connector on the hard drive.

---

**Note:** If your SATA hard drive comes with a legacy 4-pin power connector, use the 4-pin power connector instead. To connect to both IDE hard drive and SATA hard drive with legacy 4-pin power connector, you need a 4-pin Y type power cable to convert a single 4-pin power connector into a double 4-pin power connector.

---

3. Connect the single DC output connector of the power adapter to the **DC IN** jack on the adapter. Then connect the supplied power cord to the power adapter and the other end to an AC outlet.

### Connecting IDE Drive

1. Connect your 2.5" IDE device to the IDE connector of the adapter. To connect to a 3.5" IDE hard drive or 5.25" CD/DVD drive, connect the 2.5" to 3.5" IDE converter first.
2. If a 3.5" or 5.25" IDE device is connected, using the provided power cable, connect the mini 4-pin end to the adapter's **DC** connector and the big 4-pin female end to the power connector on the IDE drive.
3. Connect the single DC output connector of the power adapter to the **DC IN** jack on the adapter. Then connect the supplied power cord to the power adapter and the other end to an AC outlet.

---

**Caution:** The adapter supports bus-power if only a 2.5" hard drive is connected. However, USB port power output varies between computers. If your system cannot detect the 2.5" hard drive, it could be that the USB port cannot supply sufficient power, and thus additional power connection is required.

---

## Connecting to Computer

Connect one end of the USB cable to the adapter and the other to a free USB port on the computer.

## Driver Installation (For Windows 98SE Only)

The adapter is Plug-and-Play under Windows XP, 2000, ME and MAC OS. No need to install a third party driver.

Windows 98SE users need to download the driver from the website. After the download, double-click the setup file and the following message will appear. Click **OK** and then connect the adapter to the USB port of the computer. If the hard drive is not detected upon USB connection, reboot your computer.

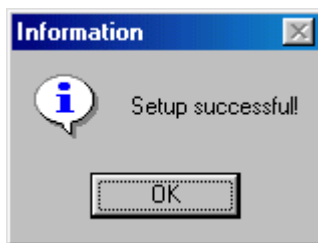

## Using the Hard drive

Now you are ready to use the attached hard drives as external USB 2.0 storage device. (A brand new hard drive must be partitioned and formatted first. You can use Windows Disk Management utility in Windows XP/2000 or other disk management software to perform disk-related tasks. Please refer to your software documentation for instructions.

Under Windows, the external hard drive(s) should be displayed in **My Computer**. An USB device monitor icon will appear on the notification area of the taskbar.

Hard Disk Drives			
Local Disk (C:)	Local Disk	2.43 GB	599 MB
DATA (D:)	Local Disk	7.99 GB	7.30 GB
DATA2 (E:)	Local Disk	14.60 GB	11.10 GB

\* Drive name and letter vary accoring to your configuration.

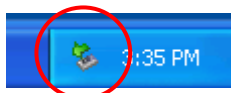



Under Mac, the attached hard drive will be mounted to the desktop and appears as a removable media device.

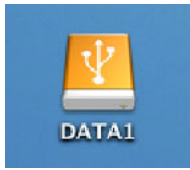

You can read and write files from and to the device as you would with an ordinary hard drive.

## 3. Specifications

Item	Description
<b>Serial ATA Interface</b>	Compliant with Serial ATA 1.0a
<b>Parallel ATA Interface</b>	Ultra ATA/133 Parallel Interface
<b>USB Interface</b>	USB 2.0 specification and backward compatible with USB 1.1 Transfer speed: 1.5/12/480 Mbps
<b>Connectors</b>	<b>SATA:</b> 7-Pin Signal male Type Connector <b>IDE:</b> IDE 44 pin female connector (2.5" to 3.5 converter: IDE 44 male to 40 female) <b>USB:</b> USB 2.0 Type A male connector <b>DC:</b> Mini 4-pin power connector <b>DC IN:</b> 2.1mm power plug jack
<b>Power Source</b>	<b>Input:</b> AC 100-240V <b>Output:</b> 12V DC/2A
<b>System Support</b>	<b>Windows:</b> Windows 98SE/ME/2000/XP <b>Macintosh:</b> Mac 8.6 or higher
<b>Certificated</b>	FCC, CE.

\* Specification is subject to change without further notice.

## 4. Regulatory Compliance

### FCC Conditions

This equipment has been tested and found to comply with Part 15 of the FCC Rules. Operation is subject to the following two conditions:

- (1) This device may not cause harmful interference
- (2) This device must accept any interference received. Including interference that may cause undesired operation.

### CE

This equipment is in compliance with the requirements of the following regulations:  
EN 55 022: CLASS B

### WEEE Information

For EU (European Union) member users:

According to the WEEE (Waste electrical and electronic equipment) Directive, do not dispose of this product as household waste or commercial waste. Waste electrical and electronic equipment should be appropriately collected and recycled as required by practices established for your country. For information on recycling of this product, please contact your local authorities, your household waste disposal service or the shop where you purchased the product.



## Free Manuals Download Website

<http://myh66.com>

<http://usermanuals.us>

<http://www.somanuals.com>

<http://www.4manuals.cc>

<http://www.manual-lib.com>

<http://www.404manual.com>

<http://www.luxmanual.com>

<http://aubethermostatmanual.com>

Golf course search by state

<http://golfingnear.com>

Email search by domain

<http://emailbydomain.com>

Auto manuals search

<http://auto.somanuals.com>

TV manuals search

<http://tv.somanuals.com>