



SmartStar[®] iEQ75-GT[™]

Instruction Manual

Table of Content

| | |
|--|----|
| Table of Content | 2 |
| 1. iEQ75-GT™ Overview | 4 |
| 2. iEQ75-GT™ Assembly | 5 |
| 2.1. Parts List | 5 |
| 2.2. Assembly terms | 7 |
| 2.3. iEQ75-GT™ Ports | 8 |
| 2.4. Introduction | 8 |
| 2.5. iEQ75-GT Assembly | 9 |
| 3. GoToNova® 8406 Hand Controller | 16 |
| 3.1. Key Description | 16 |
| 3.2. The LCD Screen | 17 |
| 4. Getting Started | 18 |
| 4.1. Setup the Mount and Polar Alignment | 18 |
| 4.2. Manual Operation of the Mount | 18 |
| 4.3. Setting Up the Hand Controller | 18 |
| 4.3.1. Set Up Local Time | 18 |
| 4.3.2. Set Up Observation Site | 19 |
| 4.3.3. Set N/S Hemisphere | 20 |
| 4.3.4. Initial Star Alignment | 20 |
| 4.3.5. Go to the Moon | 20 |
| 4.4. Turn Off the Mount | 21 |
| 5. Complete Functions of GoToNova® Hand Controller | 22 |
| 5.1. Slew to an Object | 22 |
| 5.1.1. Planets, Sun, Moon | 22 |
| 5.1.2. Deep sky objects | 22 |
| 5.1.3. Comets | 22 |
| 5.1.4. Asteroids | 22 |
| 5.1.5. Stars: | 22 |
| 5.1.6. Constellations | 23 |
| 5.1.7. Enter R.A. DEC | 23 |
| 5.2. Sync to Target | 23 |
| 5.3. Electric Focuser | 23 |
| 5.4. Set Up Controller | 23 |
| 5.4.1. Set Up Local Time | 23 |
| 5.4.2. Set Up Observation Site | 23 |
| 5.4.3. Set N/S Hemisphere | 23 |
| 5.4.4. Set Display Contrast | 23 |
| 5.4.5. Set Eyepiece Light | 23 |
| 5.4.6. Set Backlight | 23 |
| 5.4.7. Set Backlash Value | 24 |
| 5.4.8. Set Key Beep | 24 |
| 5.4.9. Reset All | 24 |
| 5.4.10. Meridian Protection | 24 |
| 5.4.11. Set Language | 25 |
| 5.4.12. Heating Controller | 25 |
| 5.4.13. Upgrade Firmware | 25 |
| 5.4.14. Firmware Version | 25 |
| 5.4.15. Set Speed Limit | 25 |

| | |
|---|----|
| 5.5. Align..... | 25 |
| 5.5.1. One-Star Align..... | 25 |
| 5.5.2. Two-Star Align..... | 25 |
| 5.5.3. Dis R.A axis error..... | 26 |
| 5.5.4. Polaris Position..... | 26 |
| 5.6. PEC Option..... | 26 |
| 5.7. Set Up Tracking..... | 26 |
| 5.8. Auto Guide | 26 |
| 5.8.1. Set Guider Rate..... | 26 |
| 5.8.2. Set Guider Direction..... | 26 |
| 5.9. Park Scope..... | 27 |
| 5.9.1. Park Scope | 27 |
| 5.9.2. Set Park Position..... | 27 |
| 5.10. To Zero Position..... | 27 |
| 6. Maintenance and Servicing | 28 |
| 6.1. Maintenance | 28 |
| 6.2. iOptron Customer Service | 28 |
| 6.3. Product End of Life Disposal Instructions | 28 |
| 6.4. Battery Replacement and Disposal Instructions..... | 28 |
| Appendix A. Technical Specifications..... | 29 |
| Appendix B. GoToNova [®] 8406 HC MENU STRUCTURE..... | 30 |
| Appendix C. Firmware Upgrade | 32 |
| Appendix D. Use a PC to Control an iEQ75-GT Mount..... | 33 |
| Appendix E. GoToNova [®] Star List | 34 |
| IOPTRON TWO YEAR TELESCOPE, MOUNT, AND CONTROLLER WARRANTY..... | 41 |



WARNING!

***NEVER USE A TELESCOPE TO LOOK AT THE SUN WITHOUT A PROPER FILTER!
Looking at or near the Sun will cause instant and irreversible damage to your eye. Children
should always have adult supervision while observing.***

1. iEQ75-GT™ Overview

The iEQ75-GT™ is a one-of-a-kind premium CNC-machined astro-imaging mount from iOptron. The iEQ75-GT™ offers the next generation GoTo technology from iOptron. With a Renishaw high resolution encoder-enabled double closed-loop tracking, the system is able to tracking the target with a tracking error less than ± 1 arcsec. The iEQ75-GT™ has a payload of 75 lb (34 kg) and includes a calibrated dark field illumination polar scope. Its unique base design makes it easy for just one person to carry to location.

Features:

- Premium CNC-machined astrophotography mount suited for advanced imaging
- Heavy duty German equatorial mount
- Maximum payload: 75 lb (34 kg) (excluding counterweight)
- Mount weight: 52 lb (23.6 kg)
- Angular contact ball bearings for R.A and DEC axles, as well as worm gear shafts
- Precision DC servo motor-driven and double closed-loop tracking with Renishaw high resolution encoder feedback
- 32-bit ARM system for ultra-accurate tracking with temperature-compensated crystal oscillator (TCXO)
- Maximum tracking error: ± 1 arc second
- Advanced GOTO™ technology for accurate GOTO and tracking
- Built-in 32-channel Global Positioning System (GPS)
- Integrated ST-4 autoguiding port capable of reverse guiding with auto-protection
- Hand Box (HBX) port for hand controller connection
- iOptron port for electronic focuser, laser pointer, planetary dome control
- RS232 port for firmware upgrading and computer control via ASCOM platform
- Calibrated polar scope with dark-field illumination and easy polar alignment procedure, allowing for fast and accurate polar alignment
- Heated hand controller for low temperature operation as low as -20°C
- Comes standard with:
 - a mounting plate for Vixen or Losmandy-D saddles
 - a Vixen dovetail saddle
 - stainless steel counterweight shaft with safety lock
 - 2 x 16.5 lb (7.5 kg) stainless steel counterweights
 - 12V DC car plug adaptor
 - USB cable
 - RS232 Cable
- Optional tripod or pier

2. iEQ75-GT™ Assembly

2.1. Parts List¹

The parts comes with the iEQ75-GT™ order include an EQ mount (Figure 1), one mounting plate (Figure 2), 2 counterweights and an CW shaft (Figure 1). Other parts are, as shown in Figure 4, an 8406 hand controller, coiled hand controller cable, a Vixen dovetail saddle, R.A. and DEC cables, a dark field illuminating LED with cable, a 12V DC adapter cable with car lighter plug, a USB Cable, a RS232 cable, GPS antenna, a hex key set, 4 base mounting screws, and 8 M6X20 hex head screws



Figure 1. iEQ75-GT mount

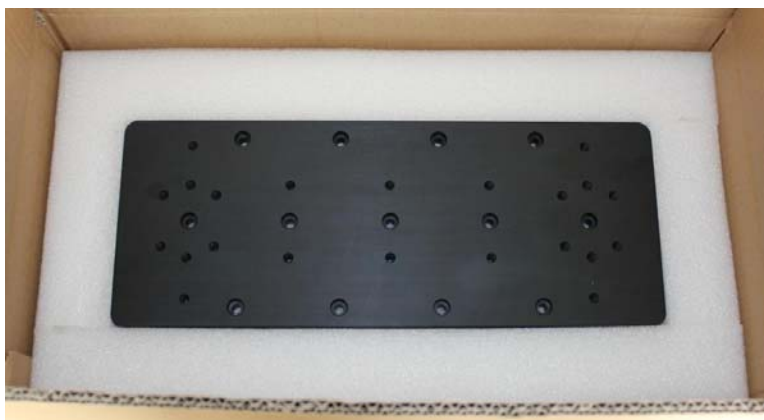

Figure 2. Mounting plate

¹ Actual contents may vary from time to time.



Figure 3. Counterweights and CW shaft



Figure 4. Included accessories

2.2. Assembly terms

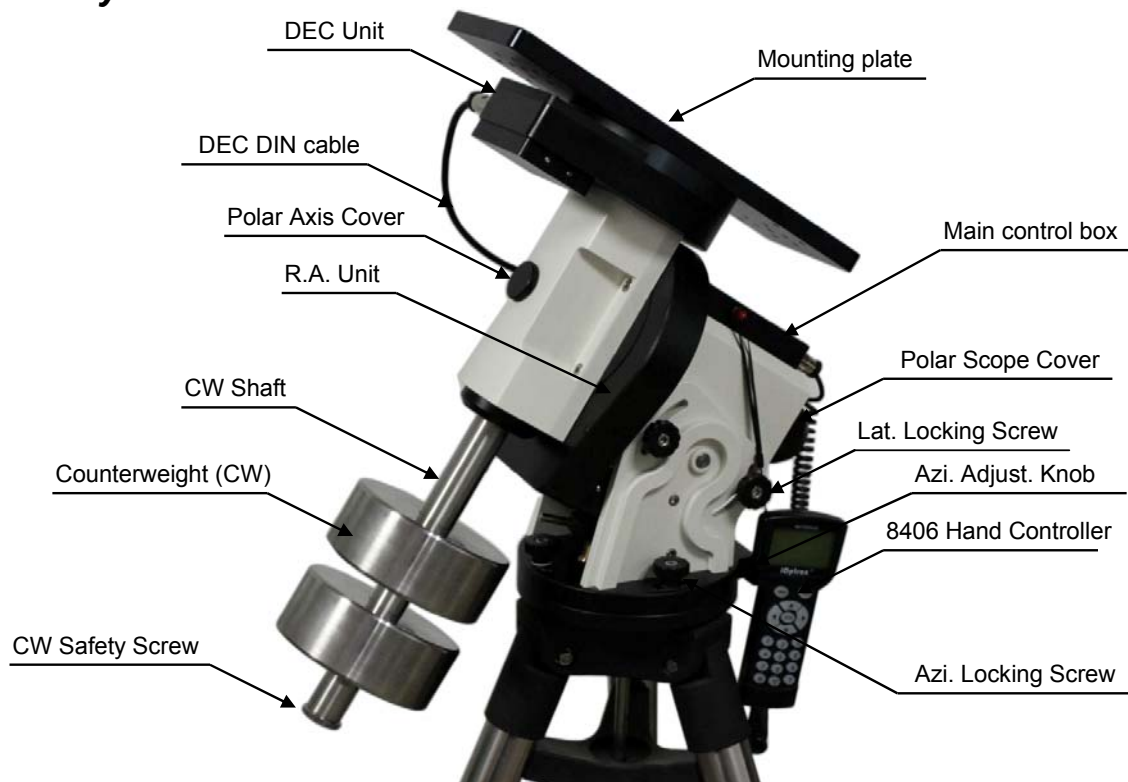

Figure 5. iEQ75-GT assembly terms (mount and optional tripod)

2.3. iEQ75-GT™ Ports



Figure 6. Ports on iEQ75-GT™ control box

- R.A. and DEC motor: For connecting to R.A. and DEC driver unit
- Power: Power switch
- DC 12V: 12 volts DC power plug (center positive)
- HBX (Hand Box): For connecting to the 8406 Hand Controller
- iOptron port: For connecting to other iOptron accessories, such as an electronic focuser, a laser pointer, or a planetary dome control
- RS232: Series port for ASCOM control and main board firmware upgrade
- Autoguide: Autoguiding port for ST-4 compatible guiding cameras
- GPS: GPS antenna connection
- Reticle: Power supply for the Polar Scope dark field illumination LED

2.4. Introduction

You have just purchased a telescope mount that is capable of taking you to a new level of astronomy. No matter which telescope or optical tube assembly (OTA) you select to install on the mount, the overall performance will be greatly enhanced. In order for you to get the optimum performance from the mount and OTA combination, you must assemble and adjust the mount correctly. The following fundamentals of telescope mounts are included to help you understand the big picture before you get into the specific details of the iEQ75-GT mount.

Telescope mounts are either equatorial mounts or altitude-azimuth (Alt-Az) mounts. Both types of mounts rotate the OTA around two perpendicular axes to point to a desired object in the night sky. An equatorial mount has the right ascension (R.A.) axis aligned with the celestial North Pole (CNP), or celestial South Pole (CSP), to provide rotation matching the celestial sphere rotation around the Earth and the declination axis (DEC) to provide elevation relative to the celestial equator. Since all celestial objects appear to rotate around the CNP, the R.A. axis allows the OTA to rotate with the celestial sphere and provide accurate tracking for visual observations and astrophotography. R.A. is the celestial equivalent of longitude. Like longitude, R.A. measures an angle that increases toward the East as measured from a zero reference point on the celestial equator. An Alt-Az mount has a horizontal axis to provide vertical (altitude) OTA movement from the local horizon and a vertical axis to provide horizontal (azimuth) OTA movement, similar to compass headings. An Alt-Az mount can provide tracking that is good enough for visual observing

and short exposure photos, but not good enough for serious astrophotography. Alt-Az mounts require star alignments for the OTA to track stars and they do not have adjustment components on the mount. Equatorial mounts require alignment of the mount components as well as star alignments for accurate OTA tracking.

In order to provide the required Polar Axis alignment, equatorial mounts use a combination of both mount types described above. The adjustable part of the mount moves in the Alt-Az mode in order to align the R.A. axis, also known as the mount's Polar Axis, with the CNP. These Polar Axis adjustments do not involve any rotations of the OTA about the R.A. or DEC axes and can be performed without the OTA installed. The first step is to make an approximate azimuth alignment of the Polar Axis by aligning the specified tripod leg or reference point toward True North using a compass for reference (you must allow for the variation between True and Magnetic North at your location). Precise horizontal alignment of the Polar Axis is accomplished with azimuth adjustments on the mount. The second step is to adjust the Polar Axis vertically (altitude) above the North horizon by setting the observer's latitude on the provided latitude scale. This procedure is based on the fundamental geometry of the Earth's coordinate system in conjunction with the concept of the celestial sphere. You can verify this by visualizing yourself at the North Pole (latitude $N90^\circ$) and Polaris will be 90° from the horizon, or directly overhead. These steps will place the Polar Axis very close to the CNP. Both of the above adjustments can be enhanced by the use of an opening along the R.A. axis that allows direct viewing of the North Star and the use of a polar scope to view through this opening. If you are going to get the most out of your equatorial mount it is essential to understand the concept of the Polar Axis and how the equatorial mount helps you establish and maintain a true Polar Axis alignment. Now, you are ready to perform star alignments using the equatorial mount's electronic controller and enjoy the night sky.

The iEQ75-GT is a next-generation equatorial mount that provides the precision alignment capabilities required for today's complete astronomy solution. The following sections of this manual provide the detailed steps required to successfully set up and operate the iEQ75-GT.

2.5. iEQ75-GT Assembly

NOTE: The iEQ75-GT is a precision astronomical instrument. It is highly recommended that you read the entire manual and become familiar with the nomenclature and function of all components before starting the assembly.

STEP 1. Setup Tripod

Expand the tripod legs and install the Tripod Support using the Tripod Lock as shown in Figure 7. Tightening the Tripod Lock will expand the tripod legs fully and provide maximum support for the mount and the Optical Tube Assembly (OTA). Adjust the tripod height by unlocking the tripod Leg Lock Screws, sliding the lower tripod leg to the desired length, and relocking the tripod Leg Lock Screws. It is recommended that you extend the legs fully during the first assembly and modify the length as required in subsequent adjustments. After the legs are adjusted and locked, stand the tripod with the Alignment Peg facing True South. If you are located in the southern hemisphere, face the Alignment Peg True North.

STEP 2. Attach the iEQ75-GT Mount

Locate the Azimuth Adjustment Knobs and retract them to allow enough clearance for the mount to fit on the tripod head. Unscrew the four (4) Azimuth Locking Screws shown in Figure 8. Place the mount onto the Tripod Head with the alignment notch on top of the Alignment Peg. Place the four (4) Azimuth Locking Screws back and tighten the screws. Level the tripod base by adjusting the individual legs. You need a level to check leveling.



Figure 7. Tripod



Figure 8. Attaching the mount

STEP 3. Connect Cables



Figure 9. Cable connections

There are two DIN 6 cables that have C091 connectors on both ends of the cable. Insert one end of the DIN 6 cable into the R.A. socket on the control box, and the other end into the socket located on R.A. driver unit, as shown in Figure 9. Secure both ends of the DIN 6 cable. Connect another DIN 6 cable between the DEC socket on the control box and the DEC socket on DEC driver unit. Attach the DIN 6 end of a DIN-RJ-11 cable into the HBX socket on the control box and the RJ-11 end into the hand controller. Connect the GPS antenna into the GPS socket on the control box. Plug the 12V DC power supply (center positive) into the Power socket on the control box. The back light of the hand controller will illuminate when the power switch is turned on.

STEP 4. Set the Location Latitude

This step requires you to know the latitude of your current location. This can be found from your 8406 hand controller after the embedded GPS receives the signal from the satellites. It also can be easily found on the Internet, with your GPS navigator or a GPS capable cell phone. You will have to change this latitude setting every time you significantly change your night sky viewing location.



Figure 10. Adjust latitude

Unscrew the Latitude Adjustment Lever from the Latitude Adjustment Knob as shown in Figure 10. Turn the Latitude Adjustment Knob to set your current latitude, using the Latitude Adjustment Lever for a fine adjustment, if needed. At this point, with the mount level and pointed North, and the latitude set, the Polar Axis (R.A. axis) should be pointing very close to the NCP and Polaris.

CAUTION: For safety reasons, always adjust the latitude without an OTA and/or counterweights installed. Also, it is much easier to make this precise adjustment without a load on the axis being adjusted.

STEP 5. Polar Alignment

As explained in the introduction, an equatorial mount must have an accurate polar axis alignment in order to track properly. With the iOptron innovative Polar Scope and Quick Polar Alignment procedure, you can do a fast and accurate polar axis alignment.

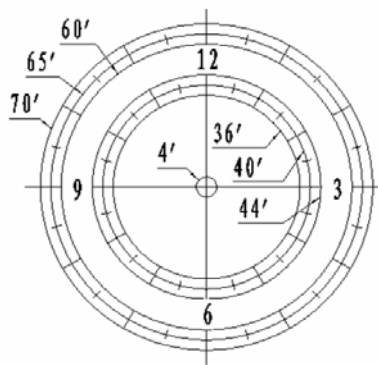

Figure 11. Polar Scope Dial

As indicated in Figure 11, the Polar Scope Dial has been divided into 12 hours along the angular direction with half-hour tics. There are 2 groups, 6 concentric circles marked from 36' to 44' and 60' to 70', respectively. The 36' to 44' concentric circles are used for polar alignment in northern hemisphere using Polaris. While the 60' to 70' circles are used for polar alignment in southern hemisphere using Sigma Octantis.

Polar axis adjustments

Whenever polar axis adjustments are required, loosen the four Azimuth Locking Screws and adjust the Azimuth Adjustment Knobs to do a fine adjustment of the mount in the azimuth direction. Tighten

the locking screws to secure the mount. Loosen four Latitude Locking Screws on the side of the mount, turning the Latitude Adjustment Knob to adjust the latitude (altitude). Use the Lever for a fine latitude adjustment. Re-tighten the lock screws.

Initializing the polar scope

During initial setup of the iEQ mount, it is likely that the viewing hole on the DEC axis of the polar scope may be blocked by the DEC axle. The Polar Scope Dial in the polar scope should be set at the normal clock position with 12 o'clock located at the top, as shown in Figure 11. Before doing the Quick Polar Axis Alignment, complete the following steps:

- (1) Take off both the Polar Axis Cover and the Polar Scope Cover from the mount.
- (2) Thread the dark field illuminating LED end into the threaded hole and plug the other end into the Reticule socket located on the control box (Figure 12). The illumination intensity can be adjusted using the hand controller (HC) via the **"Set Eyepiece Light"** function under the **"Set Up Controller"** menu.
- (3) Use the **UP** or **DOWN** button to turn the DEC axle if it blocks the Polar Scope view, press number buttons to change the slew speed.
- (4) If the 12 o'clock of the Polar Scope dial is not at the top, as shown in Figure 11, rotate it using HC's **LEFT** or **RIGHT** button.



Figure 12. Connect the illumination LED to Polar Scope

NOTE: Do not disassemble the Polar Scope to rotate it. It is adjusted at the factory and can be misaligned if you disassemble it. A good Polar alignment is the basis for good GOTO and tracking performance.

Quick polar axis alignment

- (1) Turn on the mount power by pressing the **On/Off** switch on the R.A. unit. After **"GPS OK"** is shown in the upper right corner of the HC, the LCD will display the Polaris Position as shown in Figure 13 (a). If you are practicing inside or when there is no GPS signal, you can view this chart by pressing the **MENU** button, then select **"Align"** and **"Polaris Position"**. For example, on May 30, 2010, 20:00:00 in Boston, US (Lat N42°30'32" and Long W71°08'50"), 300 min behind UT, the Polaris Position is 1hr 26.8m and $r = 41.5m$, as shown in Figure 13 (a).
- (2) Look through the polar scope; make sure the polar scope is not blocked by the DEC axle. The 12 o'clock indicator of the Polar Scope Dial must be positioned on top.
- (3) Follow the ***Polar axis adjustment*** procedure (**not the hand controller**) to adjust the mount in altitude (latitude) and azimuth (heading) direction and place Polaris in the same position on the

Polar Scope Dial as indicated on the HC LCD. In this case, the Polaris will be located at a radius of 41.5' and an angle of 1 hour 26.8 minute, as shown in Figure 13 (b).

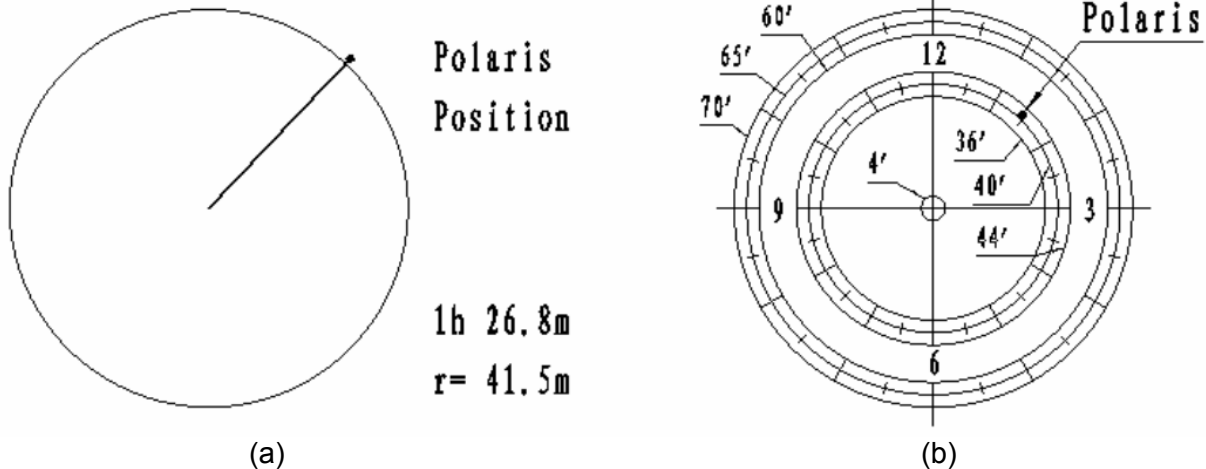

Figure 13. Polaris displayed on 8406 hand controller (a) and Polaris located on Polar scope dial

STEP 4. Attach Dovetail Adapter

Install the Mounting Plate onto the iEQ75-GT mount. Both Vixen (included) and Losmandy-D dovetail saddles can be used. The mounting-hole distribution on the Mount Plate is shown in Figure 14.

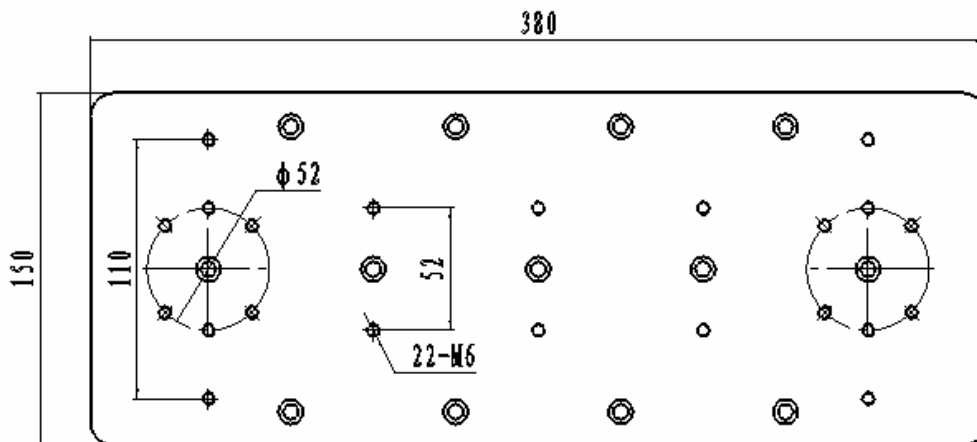

Figure 14. The mounting-hole distribution on the Mount Plate

STEP 7. Install Counterweight(s)

iEQ75-GT comes with two 16.5 lb (7.5 kg) stainless steel counterweights (CWs). Use one or both CWs as required for your particular OTA. Additional CW(s) may be needed to balance a heavier OTA (Optional CWs are available from iOptron).

CSUTION: The mount must be at the zero position when the counterweights are being installed. The Zero Position is the position with the CW shaft pointing toward the ground, as shown in Figure 15. Use your hand controller to move the mount.



Figure 15. Zero position

Remove the CW Safety Screw on the end of the CW shaft. Loosen the CW Locking Screw on the side of the CW (there is a CW pin inside) and slide the CW into the shaft. Tighten the CW Locking Screw to hold the CW in place. Tighten the CW Safety Screw.

CAUTION: For safety reasons, the CW Safety Screw must be installed and tightened to prevent the CW from dropping off the end of the CW shaft. This can cause serious personal injury.

STEP 8. Attach and Balance an OTA on the Mount

After attaching an OTA and accessories to the mount, the mount must be balanced to ensure minimum stress on the mount's gears and motors. There are no clutch screws on either R.A. or DEC axes. The balancing is performed using iOptron Electronic Balance technology.

Set the mount at Zero Position first. If it is not, turn the mount on, press the arrow key on the hand controller to adjust the mount position. Press number key on the hand controller to select appropriate speed. After the Zero Position is adjusted, turn the power off.

Balance the mount in R.A. and DEC axes

When the mount is rest at Zero Position, turn the mount power on. Press the **MENU** button, scroll down to "**Balance Test**", and press **ENTER**. The mount will start to slew and stop at the balance test position, as shown in Figure 16.



Figure 16. Balance test position

A "Testing R.A. Balance" screen will be displayed. Press the **ENTER** key to start the test. After few swings, a test results will be displayed on the hand controller LCD screen:

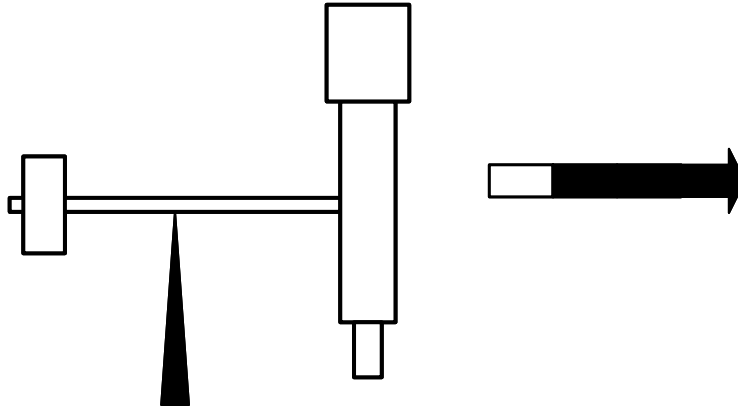

Figure 17. R.A. Balance Test

Follow the arrow indicator to move the CW left or right. The more the arrow is shaded, the more the CW needs to be moved. Press the **ENTER** key to test it again, until the **OK** sign is displayed or $\frac{1}{4}$ or less of the arrow key is shaded.

Press **◀ ▶ ▲ ▼** button on the hand controller to toggle between R.A. and DEC testing. Press **ENTER** to start the DEC balance test. Move the telescope back and forth to balance the OTA around the DEC axis.

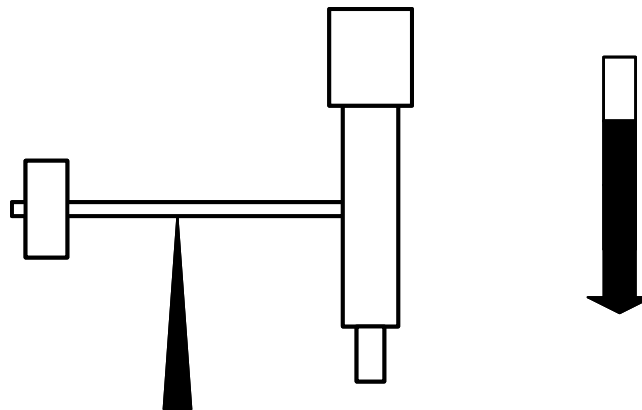

Figure 18. DEC Balance Test

NOTE: If you are located in southern hemisphere, Sigma Octantis will be chosen for Polar Alignment. For example, on May 20, 2010, 20:00:00 in Sydney, Australia (Lat S33°51'36" and Long E151°12'40"), 600 min ahead of UT, the Sigma Octantis Position is 1hr21.8m and 64.4m.

3. GoToNova[®] 8406 Hand Controller



Figure 19. GoToNova 8406 hand controller

The GoToNova[®] 8406 hand controller (HC) shown in Figure 19 is the standard controller for the iEQ75-GT mount. It has an integrated temperature controller that ensures it can be operated below 20°C (-4°F).

3.1. Key Description

- MENU Key: Press “MENU” to enter the Main Menu.
- BACK Key: Move back to the previous screen, or end/cancel current operation, such as slewing.
- ENTER Key: Confirm an input, go to the next menu, select a choice, or slew the telescope to a selected object.
- Arrow (▲▼◀▶) Keys: The arrow keys are used to control the movement of DEC and R.A. axes. Press and hold ▲(DEC+),▼(DEC-) buttons to move a telescope along the DEC direction, ◀(R.A.+), ▶(R.A.-) to move a telescope along the RA direction. They are also used to browse the menu or move the cursor while in the menu.
- Number Keys: Input numerical values. Also used to adjust speeds (1: 1X; 2: 2X; 3: 8X; 4: 16X; 5: 64X; 6: 128X; 7: 256X; 8: 512X; 9: MAX)
- Light Key(☀): Turns on/off the red LED reading light on the back of the controller.
- ? Key: For help or extra information.
- STOP/0 Key: Stop/Start tracking.
- HBX (Handbox) port: connect the HC to the iEQ75-GT mount using a 6-wire RJ11 cable.
- USB port: connect the HC to a Computer via a USB cable.

3.2. The LCD Screen

The 8406 HC has a large 8-line, 21 character LCD screen, which displays all the information as shown in Figure 20. The user interface is simple and easy to learn.

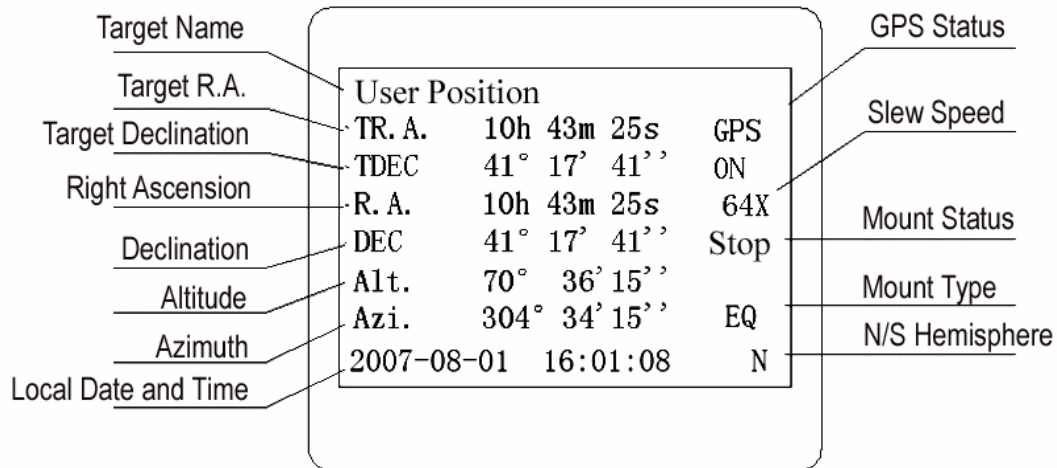

Figure 20. 8406 HC LCD Information Screen

- Target Name/Mount Position: displays the name of the target that telescope is currently pointed to or the current mount position.
 - User Position: When the mount is turned on.
 - An object name, such as "Mercury" or "Andromeda Galaxy": Name of the Star or celestial object that the mount is currently slewing to, GOTO or tracking;
 - User R.A. DEC. Now: The mount is slewed to a target with manually entered R.A. and DEC numbers;
 - Zero Position: The mount is moved to Zero Position using "**To Zero Position**" command;
 - Park Position: Display one of six scope parking position, such as "Up North" after using "**Park Scope**" command.
- Target R.A.: Right Ascension of the target object.
- Target Declination: Declination of the target object.
- Right Ascension: Right Ascension of the telescope, or R.A.
- Declination: Declination of the telescope, or DEC.
- Altitude: Altitude of the telescope (degrees vertical from the local horizon - zenith is 90°).
- Azimuth: Azimuth of the telescope (north is 0°, east 90°, south 180°, and west 270°).
- Local Date and Time: display local time in a format of YYYY-MM-DD.
- Mount Status: Display the current operation or tracking status of the mount.
 - Stop: mount is stop moving;
 - Slew: mount is slewing to a target;
 - Cel: mount is tracking at a celestial speed;
 - Sol: mount is tracking at a solar speed;
 - Lun: mount is tracking at a lunar speed;
 - King: mount is tracking at a user defined tracking speed.
- Slew speed: It has 9 speeds: 1X, 2X, 8X, 16X, 64X, 128X, 256X(1°/sec), 512X(2°/sec), MAX(~ 4°/sec).
- GPS status: When the power is turned on, it shows "GPS ON", which means a GPS receiver is properly connected. When the GPS receiver finds the satellites and receives the GPS signal, it shows "GPS OK". The "GPS OK" may turn off after few minutes to save power.

4. Getting Started

In order to experience the full GOTO capability of GoToNova technology it is very important to set up the mount correctly before observation.

4.1. Setup the Mount and Polar Alignment

Setup and polar alignment your iEQ75-GT mount according to Section 2.5. The default position for the mount is the Zero Position, as shown in Figure 15, when the mount is powered on: the counterweight shaft is pointing to ground, telescope is at the highest position with its axis parallel to the polar axis and the telescope is pointing to the North Celestial Pole.

4.2. Manual Operation of the Mount

You may observe astronomical objects using the arrow keys of a GoToNova hand controller.

Flip the I/O switch on the telescope mount to turn on the mount. Use **▶**, **◀**, **▼** or **▲** buttons to point the telescope to the desired object. Use the number keys to change the slewing speed. Then press **STOP/0** button to start tracking.

4.3. Setting Up the Hand Controller

The iEQ75-GT is equipped with a GPS receiver, which will receive the local time, longitude and latitude information from satellites after the link is established. A clear sky outside is needed for the GPS to establish its link with the satellites.

4.3.1. Set Up Local Time

Press MENU button, from the main menu, scroll down and select “Set up controller”

```
Select and slew
Sync. to target
Electronic focuser
Set up controller
Align
PEC option
Set up Tracking
User objects
```

Press ENTER and select “Set up local Time”

```
Set up Local Time
Set up Observ. site
Set N/S hemisphere
Set display contrast
Set Eyepiece light
Set Backlight
Set Backlash Value
Set Key Beep
```

Press ENTER.

```
Set local time:

2008-06-01 11:55:09
Daylight Saving Time Y
```

The time will be updated automatically when the GPS has picked up a signal. You also can manually input the time information in case GPS does not function. Use the **◀** or **▶** key to move the cursor and use

number keys to change the numbers. Use the ▲ or ▼ button to toggle between “Y” and “N” for Daylight Saving Time. Press ENTER to go back the previous screen.

4.3.2. Set Up Observation Site

Scroll down and select “Set up Observ. site”

```

Set up Local Time
Set up Observ. site
Set N/S hemisphere
Set display contrast
Set Eyepiece light
Set Backlight
Set anti-backlash
Set Key Beep
    
```

Press ENTER. The longitude and latitude coordinates will be updated when the GPS picks up satellite signals. “W/E” means west/east hemisphere; “N/S” means north/south hemisphere; “d” means degree; “m” means minute; and “s” means second.

```

Set up site info:
Longitude:
    W071d27m47s
Latitude:
    N42d15m40s
300 Min. behind UT
    
```

If for any reason your GPS can't pick up a signal you can manually enter the GPS coordinates. Press ◀ or ▶ key to move the cursor and using ▲ or ▼ key to toggle between “W” and “E”, “N” and “S”, using number key to change the numbers. It is always a good idea to do your home work to get the GPS coordinates before traveling to a new observation site.

The site coordinates information can be found from *Support* section in iOptron website, under *Controller Set-up* (<http://www.ioptron.com/support.cfm?module=faq#>).By entering the city name or address, you can find its latitude and longitude. In case you only find the site information in decimal format you can convert them into d:m:s format by multiplying the decimal numbers by 60. For example, N47.53 can be changed to N47°31'48": $47.53^\circ = 47^\circ + 0.53^\circ$, $0.53^\circ = 0.53 \times 60' = 31.8'$, $0.8' = 0.8 \times 60'' = 48''$. Therefore, $47.53^\circ = 47^\circ 31' 48''$ or 47d31m48s.

Press ◀ or ▶ key, move the cursor to the bottom of the screen to set the time zone information (add or subtract 60 minutes per time zone). Enter minutes “ahead of” or “behind” UT (universal time).

- Boston is 300 minutes “behind” UT
- Los Angeles is 480 minutes “behind” UT
- Rome is 60 minutes “ahead of” UT
- Beijing is 480 minutes “ahead of” UT
- Sydney is 600 minutes “ahead of” UT

All the time zones in North America are *behind* UT, as shown in the following table. So make sure it shows “behind” instead of “ahead of” UT.

| Time Zone | Hawaii | Alaska | Pacific | Mountain | Central | Eastern |
|----------------|--------|--------|---------|----------|---------|---------|
| Hour behind UT | -10 | -9 | -8 | -7 | -6 | -5 |
| Enter Minutes | 600 | 540 | 480 | 420 | 360 | 300 |

To adjust minutes, move the cursor to each digit and use the number keys to input number directly. To change the “behind” or “ahead of” UT, move the cursor to “ahead” and using ▲ or ▼ key to toggle

between “behind” and “ahead”. When the number is correct, press ENTER and go back to the previous screen.

For other parts of the world you can find your “time zone” information from iOptron website (<http://www.ioptron.com/support.cfm?module=faq#>). **DO NOT COUNT DAYLIGHT SAVING TIME.**

The time and site information will be stored inside the HC memory chip. If you are not traveling to another observation site, they do not need to be changed.

4.3.3. Set N/S Hemisphere

If the polar axis is aligned to North Celestial Pole, then set the mount to Northern Hemisphere. If the polar axis is pointing to South Celestial pole, set the mount to Southern Hemisphere.

```
Set up Local Time
Set up Observ. site
Set N/S hemisphere
Set display contrast
Set Eyepiece light
Set Backlight
Set anti-backlash
Set Key Beep
```

Press Enter.

```
North hemisphere
South hemisphere
```

Select North Hemisphere if you are located in US and press ENTER to go back to the previous screen.

4.3.4. Initial Star Alignment

A simple star alignment/synchronization can be performed to improve the GOTO accuracy.

To perform “**One Star Align**,” press MENU button, scroll down to “**Align**”, select “**One Star Align**” and press ENTER. The screen will display a list of bright objects for you to select from. Select an object using ▲ or ▼ key. Then press ENTER. After the mount slews to the target, use the arrow keys to center it in your eyepiece. Then press ENTER. (More align details in 5.6)

An alternate way is to perform “**Sync to Target**.” Press the MENU button, select “**Select and Slew**” and press ENTER. Browse over the catalogs and select an object, such as “**Stars**” → “**Named stars**” → **140 (Polaris)**, and press ENTER. After the mount slews to Polaris, press the MENU button, scroll down to “**Sync. To Target**”, follow the on-screen instruction to center Polaris and press ENTER. You may need to use the number keys to change the slewing speed to make the centering procedure easier.

4.3.5. Go to the Moon

After performing these set-ups the mount is ready to GOTO and track objects. One of the most common objects is the Moon.

To slew to the Moon press the MENU button. Select “**Select and Slew**” by pressing the ENTER button. Select “**Planets, Sun, Moon**”, and use the ▲ or ▼ buttons to select Moon. Press ENTER. The telescope will automatically slew to the Moon and lock on it. It will automatically begin to track once it locks on. If the Moon is not centered in your eyepiece, use the arrow keys to center the Moon. Or for better performance use “**Sync to Target**.”

4.4. Turn Off the Mount

When you have finished your observation, it is recommended that you return the mount to Zero Position before powering down. This will ensure that there is no need for you to perform the initial setup again when you power up the mount subsequently, if the mount is not moved. To return the mount to its Zero Position, press the MENU button, scroll down to "To Zero Position" and press ENTER. Once the telescope returns to Zero Position turn the power off.

5. Complete Functions of GoToNova[®] Hand Controller

5.1. Slew to an Object

Press the MENU button. From the main menu select “**Select and Slew.**” Select an object that you would like to observe and press the ENTER key.

The GoToNova 8406 hand controller has a database of about 580,000 objects. Use the ► or ◀ buttons to move the cursor. Use the number buttons to enter the number, or the ▼ or ▲ buttons to change the individual number. The “☉” indicates the object is above the horizon, and a cross mark “☼” means it is below the horizon. In some catalogs those stars below the horizon will not display on the hand controller.

5.1.1. Planets, Sun, Moon

There are 10 objects in the Solar system catalog.

5.1.2. Deep sky objects

This menu includes objects outside our Solar system such as galaxies, star clusters, quasars, and nebulae.

- Named deepsky objects: consists of 60 deep sky objects with their common names. A list of named deep sky objects is included in Appendix E.
- Messier Catalog: consists of all 110 Messier objects.
- NGC IC Catalog: consists of 7,840 objects in NGC catalog and 5,386 objects in IC catalog. To select an object from NGC or IC catalog, move the cursor to NGC, using ▲ or ▼ button to toggle between NGC and IC. Then move the cursor to a numerical position and use the number button to select the object.
- UGC Catalog: consists of 12,939 objects.
- MCG Catalog: consists of 29,004 objects.
- Caldwell Catalog: consists of 109 objects.
- Abell Catalog: consists of 2,712 objects.
- Herschel Catalog: consists of 400 objects.

5.1.3. Comets

This catalog contains 233 comets.

5.1.4. Asteroids

This catalog contains 231,665 asteroids.

5.1.5. Stars:

- Named Stars: consists of 191 stars with their common names. They are listed alphabetically. A list is included in Appendix E.
- Double Stars: consists of 211 double stars. A list is attached in Appendix E.
- GCVS Variable Stars: consists of 38,624 GCVS variable stars. They are listed numerically.
- SAO Catalog: consists of 258,997 SAO catalog objects. They are listed numerically.

5.1.6. Constellations

This catalog consists of 88 modern constellations with their names. They are listed alphabetically. A list is attached in Appendix E.

5.1.7. Enter R.A. DEC

Here you can go to a target by entering its R.A. and DEC numbers.

5.2. Sync to Target

This operation will match the telescope's current coordinates to Target Right Ascension and Declination. After slewing to an object, press MENU—then scroll to “**Sync to Target**” and press ENTER. Follow the screen to do the sync. Using this function will re-calibrate the computer to the selected object. Multiple syncs can be performed if needed. This operation is most useful to find a faint star or nebula near a bright star.

“**Sync to Target**” will only work after “**Select and Slew**” is performed. Otherwise, the system may perform incorrectly. You can change the slewing speed to make the centering procedure easier. Simply press a number (1 through 9) to change the speed. The default slew speed is 64X.

“**Sync to Target**” does the same thing as one star alignment except that you choose the object to “sync” to. “**One star align**” chooses the star/object for you. “**Sync to Target**” operation will override any previously performed “**Two Star Align**” operation.

5.3. Electric Focuser

For future iOptron electric focuser use.

5.4. Set Up Controller

5.4.1. Set Up Local Time

Refer to 4.3.1.

5.4.2. Set Up Observation Site

Refer to 4.3.2.

5.4.3. Set N/S Hemisphere

Refer to 4.3.3.

5.4.4. Set Display Contrast

Use arrow keys to adjust LCD display contrast.

5.4.5. Set Eyepiece Light

If you have an illuminated-reticule eyepiece or illuminated polar scope, and it is supported by GoToNova hand controller, use this option to adjust the light intensity.

5.4.6. Set Backlight

Adjust LCD and keypad backlight.

5.4.7. Set Backlash Value

Set the backlash of R.A axis and DEC axis. Although both R.A. and DEC worms have gap-free structure, there still might be backlash or play between the reducing gears of a R.A. or DEC motor.

To set the backlash value, scroll down and select "Set Backlash Value"

```
Set up Local Time
Set up Observ. site
Set N/S hemisphere
Set display contrast
Set Eyepiece light
Set Backlight
Set Backlash Value
Set Key Beep
```

Press ENTER. A R.A. anti-backlash screen will display:

```
R.A. anti-backlash:
      0000 steps
```

To adjust steps move the cursor to each digit and use the number keys to input number directly. It is about 0.10 arc seconds per step for R.A. backlash. Press ENTER – "DEC anti-backlash" will display:

```
DEC anti-backlash:
      0000 steps
```

Move the cursor to each digit and use the number keys to set the anti-backlash. It is about 0.12 arc seconds per step for DEC backlash. Press ENTER to go back the previous screen. Press BACK button to go back to main menu.

While viewing an object in the eyepiece, observe the responsiveness of each of the four arrow buttons. Note which directions you see a pause in the star movement after the button has been pressed. Working one axis at a time, adjust the backlash settings high enough to cause immediate movement without resulting in a pronounced jump when pressing or releasing the button. The hand controller will remember these values and use them each time it is turned on until they are changed.

5.4.8. Set Key Beep

Turn the key beep on/off.

5.4.9. Reset All

Reset all settings to factory default data.

5.4.10. Meridian Protection

The Meridian Flip can be turn on or off. If the Meridian Flip is turned off, there are two more options: Meridian Protection ON or OFF.

If the Meridian Protection is turned on, the mount will stop tracking when it passes the meridian. If it is turned off, the mount will keep tracking and the OTA could hit the tripod leg if the mount is not monitored.

5.4.11. Set Language

Select hand controller language from English or French.

5.4.12. Heating Controller

Turn on/off the controller internal heater.

5.4.13. Upgrade Firmware

Use this operation to upgrade 8406 hand controller firmware and iEQ75-GT main control board firmware. Please refer to Appendix C. Firmware Upgrade for details.

5.4.14. Firmware Version

Will display hand controller firmware version.

5.4.15. Set Speed Limit

You can select the GOTO speed to be 128X, 256X, 512X, or MAX. The slower the speed, the quieter the motors run.

5.5. Align

This function is used for aligning the telescope. The system provides two alignment methods: "One Star Align" and "Two Star Align" The mount has to be at Zero Position before any star alignment.

5.5.1. One-Star Align

Press MENU button and select "**Align**". Select "**One Star Align**" and press ENTER. A list of alignment stars that are above the horizon is computed based on your local time and location. With the mount at the "Zero Position," use ▲ and ▼ buttons to select a star and press ENTER. Center the target in your eyepiece using arrow key. Press ENTER when finished. If your mount is well set up and polar aligned, one star alignment should be sufficient for good GOTO accuracy. To increase the accuracy you may choose to do two star alignment.

5.5.2. Two-Star Align

Two star alignment will increase the GOTO accuracy of the mount. Two star alignment requires a wider view of the sky, since the two align stars need to be far apart. Press MENU button and select "**Align**". Select "**Two Star Align**" in the align menu. A list of alignment stars that are above the horizon is computed based on your local time and location. With the mount is at the "Zero Position," use ▲ and ▼ buttons to select first alignment star and press ENTER. Center the target in your eyepiece using arrow key. Press ENTER when finished. The hand controller will prompt you to choose the second star. If the star you choose is too close to the first one, the system will let you choose another one. When you are aligned with the second star, the two star alignment is finished. You can reject the suggested star if it is blocked by a tree or other obstruction.

After the two-star alignment, a pointing error between the R.A. axis and the polar axis will be recorded. This number can be used to fine tune the R.A. axis.

"**Two Star Align**" results will be overridden if "**One Star Align**" or "**Sync. to Target**" is performed after "**Two Star Align**."

5.5.3. Dis R.A axis error

This displays the celestial pole pointing error after two star or three star alignment. When the HC shows for example:

7.5" lower

4.3" east,

it means the polar axis of the mount is pointing lower and to the east. Pointing error is zero when the mount is powered on (unless you "Park Telescope" before powering off).

5.5.4. Polaris Position

This shows Polaris position in the polar scope and is used for Quick Polar Alignment.

5.6. PEC Option

iEQ75-GT uses automatic real time periodic error correction technique with a Renishaw high resolution optical encoder.

5.7. Set Up Tracking

You can set up tracking in the main menu by selecting "**Set up tracking**". Then the user can select "**Solar speed**", "**Lunar speed**", "**Sidereal speed**" and "**User defined speed**". For "User defined speed," it can be adjusted from 0.9900X to 1.0100X of sidereal speed by pressing the ▲ or ▼ button or number buttons.

5.8. Auto Guide

5.8.1. Set Guider Rate

This is an advanced function for autoguiding when a guiding camera is equipped either via an ST-4 guiding port or an ASCOM protocol. Before autoguiding, align the polar axis carefully. Press **MENU** and select Auto Guide and press **ENTER**. Select a proper guiding speed. The suppositional guiding speed can be selected from 0.10X to 1.00X. Follow the autoguiding software for detailed operation.

5.8.2. Set Guider Direction

The Guide Port iEQ75-GT equipped is capable to handle an ST-4 autoguiding camera with both straight and a reverse wired RJ-11 guiding cable. Select "**Reverse**" option in the "**Auto Guide**" function for an ST-4 camera with a reversed RJ-11 guiding cable, as shown in Figure 21.

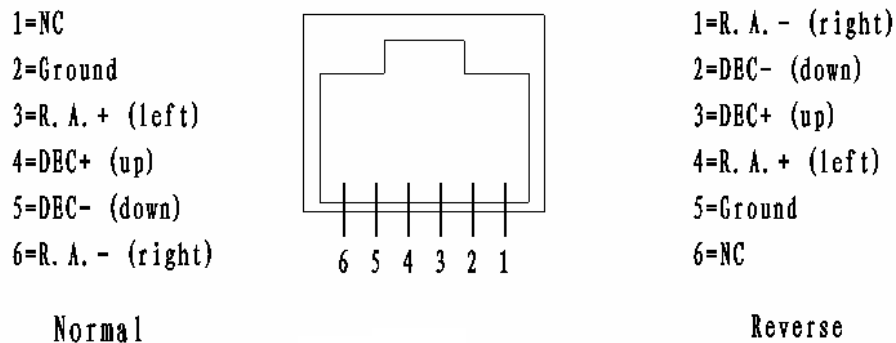

Figure 21

5.9. Park Scope

5.9.1. Park Scope

Park the mount to a preset parking position.

5.9.2. Set Park Position

There are 6 park positions to be chosen from, namely “Up north,” “Left zenith,” “Left horizontal,” “Right zenith,” “Right horizontal,” and “Position now.” Different OTA may have different requirement for parking. When the mount is powered off, the park position will be remembered. *If you selected the park position other than “Up north,” make sure you do a “**One Star Align**” before using GOTO for any object.*

This procedure only needs to be done if you do not move your telescope mount after you power off the mount. R.A. axis pointing error will be stored in flash memory and recalled when you power on again. If the power is turned off before performing “**Park Scope**” operation, all the reference information will be lost.

5.10. To Zero Position

This moves your telescope to its Zero Position. When the power is turned on, the mount assumes the Zero Position. This is its reference point for all other objects being tracked.

6. Maintenance and Servicing

6.1. Maintenance

The iEQ75-GT is designed to be maintenance free. Do not overload the mount. Do not drop the mount, this will damage the mount or degrade the GOTO tracking accuracy permanently. Use a wet cloth to clean the mount and hand controller. Do not use solvent.

If your mount is not to be used for an extended period, dismount the OTAs and counterweight(s).

6.2. iOptron Customer Service

If you have any question concerning your iEQ75-GT contact iOptron Customer Service Department. Customer Service hours are 9:00 AM to 5:00 PM, Eastern Time, Monday through Friday. In the unlikely event that the iEQ75-GT requires factory servicing or repairing, write or call iOptron Customer Service Department first to receive an RMA# before returning the mount to the factory. Please provide details as to the nature of the problem as well as your name, address, e-mail address, purchase info and daytime telephone number. We have found that most problems can be resolved by e-mails or telephone calls. So please contact us first to avoid returning the mount for repair. It is strongly suggested that to send technical questions to support@ioptron.com. Call in the U.S. 1.781.569.0200.

6.3. Product End of Life Disposal Instructions



This electronic product is subject to disposal and recycling regulations that vary by country and region. It is your responsibility to recycle your electronic equipment per your local environmental laws and regulations to ensure that it will be recycled in a manner that protects human health and the environment. To find out where you can drop off your waste equipment for recycling, please contact your local waste recycle/disposal service or the product representative.

6.4. Battery Replacement and Disposal Instructions



Battery Disposal- Batteries contain chemicals that, if released, may affect the environment and human health. Batteries should be collected separately for recycling, and recycled at a local hazardous material disposal location adhering to your country and local government regulations. To find out where you can drop off your waste battery for recycling, please contact your local waste disposal service or the product representative.

Appendix A. Technical Specifications

| | |
|----------------------------|--|
| Mount | German Equatorial Mount |
| Payload | 75 lb (34kg) |
| Mount weight | 52 lb (23.6kg) |
| Right Ascension worm wheel | Φ182mm, 228 teeth bronze |
| Declination worm wheel | Φ154mm, 192 teeth bronze |
| Right Ascension axis shaft | Φ60mm steel |
| Declination axis shaft | Φ45mm steel |
| Right Ascension bearing | Φ90mm angular contact ball bearing |
| Declination bearing | Φ68mm angular contact ball bearing |
| Worm gears | Φ15.6mm steel |
| Motor drive | Planetary Gear Reducer DC servo with encoder |
| Resolution | 0.1 arc seconds |
| Latitude adjustment range | 15° ~ 70° |
| Azimuth adjustment range | ± 7.5° |
| GPS | Internal 32-channel GPS |
| Polar Scope | Yes. (with dark field illumination) |
| Accuracy | 2 arc minutes |
| Hand Controller | GoToNova [®] 8406 with 580,000 objects database |
| Tracking controller | Double closed-loop tracking with Renishaw high resolution encoder feedback |
| Tracking error | ± 1 arc second max |
| PEC | Real-time automatic |
| Speed | 1×,2×,8×,16×,64×,128×,256×,512×,MAX(~4°/sec) |
| Counterweight shaft | Φ31.8 mm (included) |
| Counterweight | 16.5 lb (7.5kg) X 2 stainless steel (Φ150X52 mm, included) |
| Base diameter | Φ200 mm |
| Mounting plate | Black anodized aluminum (150X380mm, included) |
| Dovetail | 3.5"VIXEN Saddles included |
| Power consumption | 0.4A(Tracking), 1.2A(Slew) |
| Power requirement | 12V DC(11 ~ 15V), 3Amp, center positive |
| USB port | Yes (on hand controller) |
| RS232 port | Yes (on control box) |
| Autoguide port | Yes (ST-4 compatible) |
| Firmware upgrade | Yes (main board and hand controller) |
| PC computer control | Yes (ASCOT) |
| Operation temperature | -20°C ~ 40°C |

Appendix B. GoToNova[®] 8406 HC MENU STRUCTURE

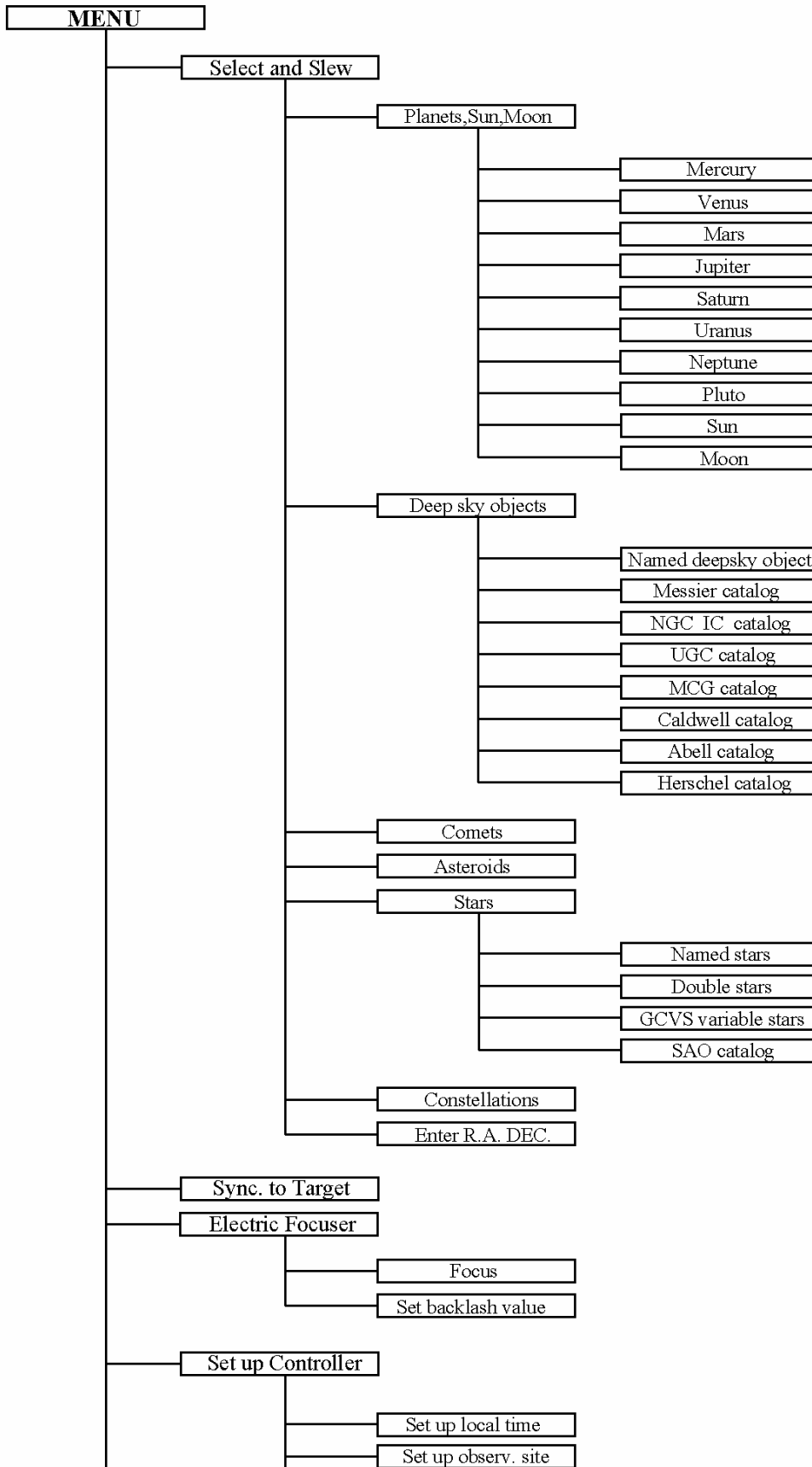

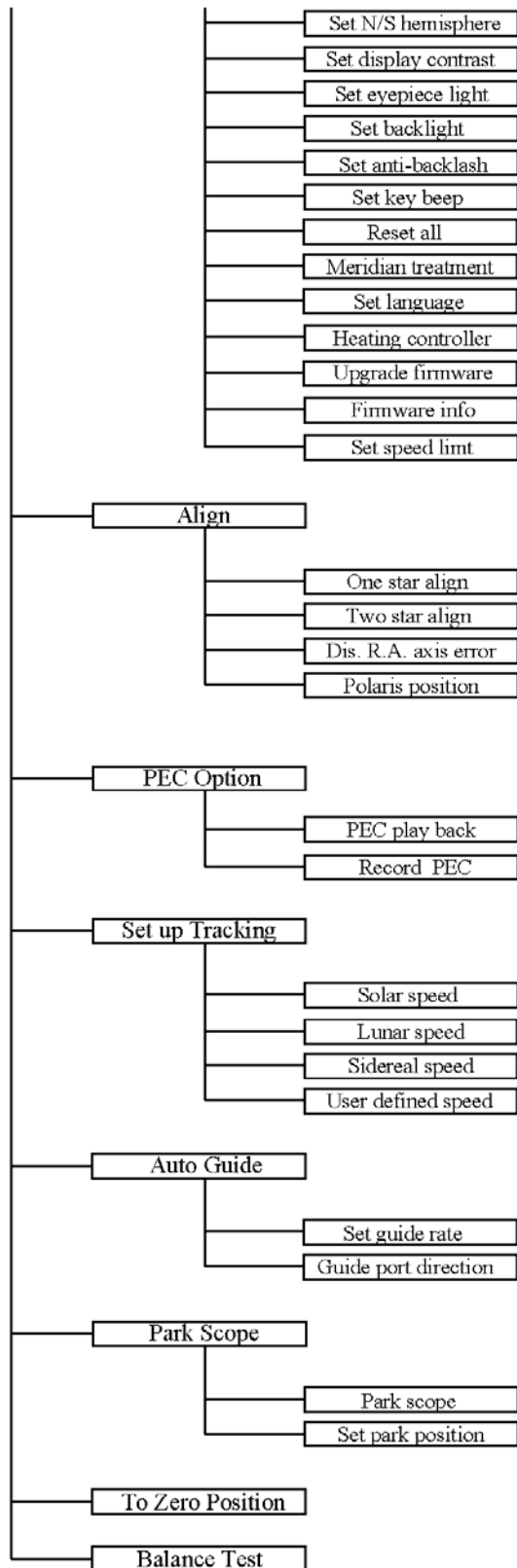

Appendix C. Firmware Upgrade

The firmware in the 8406 hand controller and/or main control board can be upgraded by the customer. Please check iOptron's website, www.iOptron.com, under Support Directory, for the most up to date firmware.

To upgrade i8406 hand controller firmware:

- (1) Download the newest version of the 8406 hand controller firmware (i8406.iop) from iOptron's website, save it on your desktop;
- (2) Connect 8406 hand controller to your computer's USB port using included USB cable;
- (3) Turn on the mount;
- (4) Press MENU and select "**Set Up Controller**," scroll down to "**Upgrade Firmware**." A new storage drive with a drive number, e.g. "IOPTRON(E:)", will be shown under "My Computer." If it is the first time you have connected the hand controller to the computer, it may take few minutes to install the driver.
- (5) Copy the downloaded firmware, i8406.iop, into "sys" folder under IOPTRON(E:) drive to replace the original one;
- (6) Restart iEQ75-GT mount to finish the hand controller firmware upgrade.

To upgrade iEQ75-GT main control board firmware:

- (1) Download iOptron Downloader Setup from iOptron's website and save it on your desktop;
- (2) Double click on iOptron Downloader Setup to install it;
- (3) Download the newest version of iEQ75-GT main control board firmware (iEQ75-GT_main_VX.XX.bin) from iOptron website, save it on your desktop;
- (4) Connect iEQ75-GT RS232 port to your computer's serial port using supplied RS-232 cable. A USB to COM adapter is needed if your computer does not have a serial port, like most of the laptops today;
- (5) Turn on the mount;
- (6) Find your COM port number by click on windows **start**, select **Properties** on **My Computer**, click on **Hardware** and select **Device Manager**, double click on "**Ports (COM & LPT)**." In most cases, it will be COM1. (If you are using a USB to RS-232 converting cable, the COM port number will be different.)
- (7) Double click on "iOptron Download" icon to start the program;
- (8) Select the Serial Port, here is COM1. Open the data file, here is iEQ75-GT_main_VX.XX.bin. Click on Start Download. After the program prompts that "Download successfully finished," restart the mount to finish main control board firmware upgrade.

Note: Only use the iEQ75-GT bin file. Sending a wrong file into the main control board will cause the mount stop working.

Appendix D. Use a PC to Control an iEQ75-GT Mount

The iEQ75-GT mount can be connected to a computer using supplied RS232 cable, if your PC is equipped with a serial port. A RS232 to USB adapter is needed if your computer does not have a serial port, like most of the laptops on the market today. Follow the adapter instructions to install the adapter driver.

When the communication between the mount and computer has been established, the mount can be controlled via either ASCOM or RS485 protocol.

To control the mount via ASCOM protocol, you need:

1. Download and install ASCOM Platform from <http://www.ascom-standards.org/>. Make sure your PC meet the software requirement, such as Microsoft .NET Framework 3.5 Service Pack 1 is installed. Refer to the ascom-standards website for details.
2. Download and install latest iOptron Telescope ASCOM drive from iOptron website, click on **Support**, select **ASCOM Driver**.
3. Planetarium software support ASCOM protocol. Follow software instructions to select the iOptron Telescope.

Some companies have integrated iOptron's products into their planetarium software, such as Voyage and The Sky X Pro. Therefore, an ASCOM plug-in will not be needed. Most planetarium software can be used to control iOptron's product via ASCOM.

Appendix E. GoToNova[®] Star List

Messier Catalog

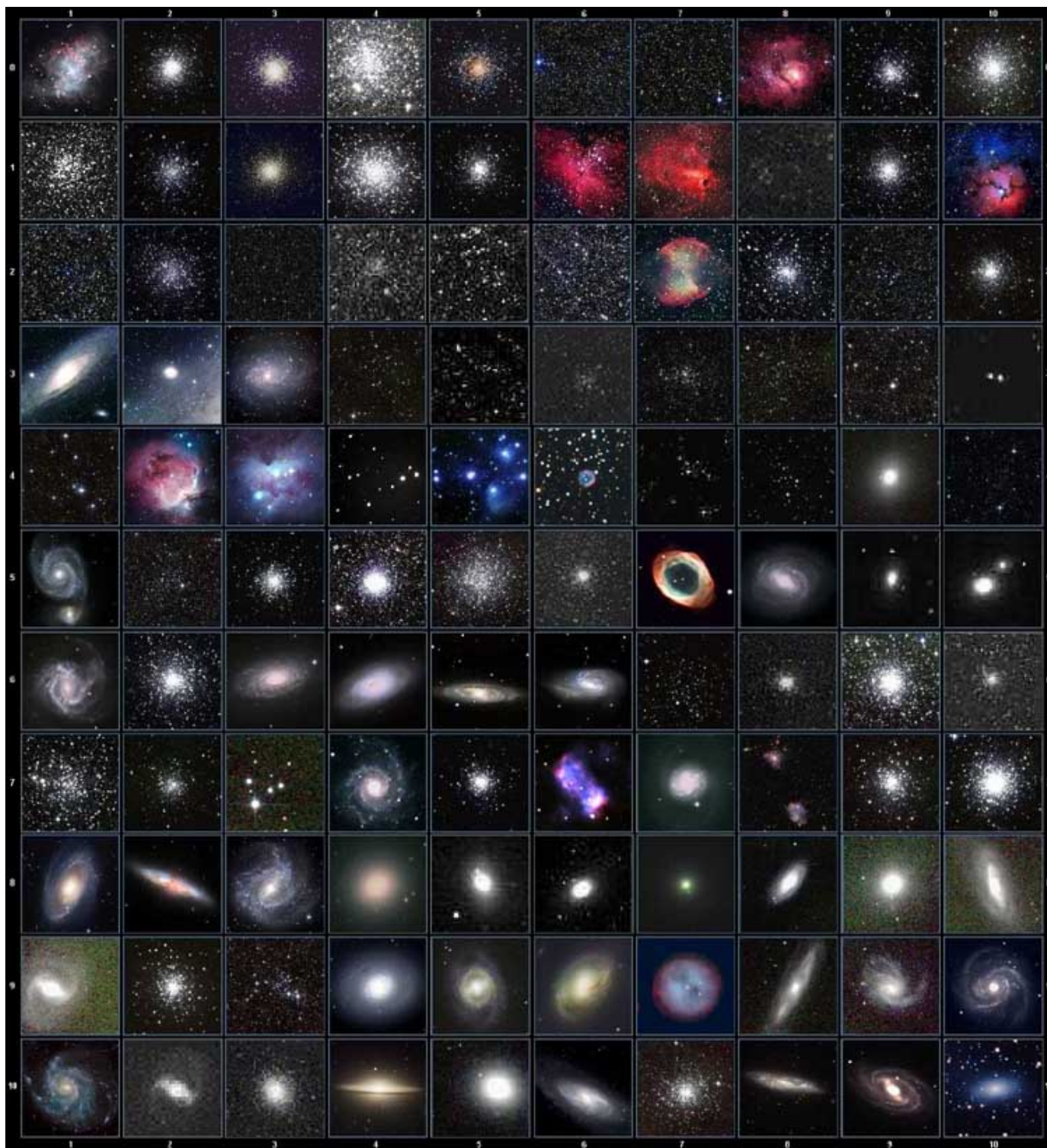

This table is licensed under the [GNU Free Documentation License](#). It uses material from the [Wikipedia article List of Messier objects](#)

GoToNova Named Star List

for 8406

| | | | |
|---------------------|-----------------------|--------------------|---------------------|
| 001 Acamar | 049 Ascella | 097 Kaus Australis | 145 Rassalas |
| 002 Achernar | 050 Asellus Australis | 098 Kaus Borealis | 146 Rasagethi |
| 003 Acrux | 051 Asellus Borealis | 099 Kaus Media | 147 Rasalhague |
| 004 Acubens | 052 Aspidiske | 100 Keid | 148 Rastaba |
| 005 Adhafera | 053 Atik | 101 Kitalpha | 149 Regulus |
| 006 Adhara | 054 Atlas | 102 Kochab | 150 Rigel |
| 007 Al Na'ir | 055 Atria | 103 Kornephoros | 151 Rigel Kentaurus |
| 008 Albali | 056 Avoir | 104 Kurhah | 152 Ruchbah |
| 009 Alberio | 057 Azha | 105 Lesath | 153 Rukbat |
| 010 Alchibar | 058 Baten Kaitos | 106 Maia | 154 Sabik |
| 011 Alcor | 059 Beid | 107 Marfik | 155 Sadachbia |
| 012 Alcyone | 060 Bellatrix | 108 Markab | 156 Sadalbari |
| 013 Aldebaran | 061 Betelgeuse | 109 Matar | 157 Sadalmelik |
| 014 Alderamin | 062 Biham | 110 Mebsuta | 158 Sadalsuud |
| 015 Alfirk | 063 Canopus | 111 Megrez | 159 Sadr |
| 016 Algedi | 064 Capella | 112 Meissa | 160 Saiph |
| 017 Algenib | 065 Caph | 113 Mekbuda | 161 Scheat |
| 018 Algiebra | 066 Castor | 114 Menkalinan | 162 Schedar |
| 019 Algol | 067 Celabrai | 115 Menkar | 163 Seginus |
| 020 Algorab | 068 Celaeno | 116 Menkent | 164 Shaula |
| 021 Alhena | 069 Chara | 117 Menkib | 165 Sheiak |
| 022 Alioth | 070 Chertan | 118 Merak | 166 Sheratan |
| 023 Alkaid | 071 Cor Caroli | 119 Merope | 167 Sirius |
| 024 Alkaluops | 072 Cursa | 120 Mesartim | 168 Skat |
| 025 Alkes | 073 Dabih | 121 Miaplacidus | 169 Spica |
| 026 Almach | 074 Deneb | 122 Mintaka | 170 Sterope |
| 027 Alnasl | 075 Deneb Algedi | 123 Mira | 171 Sulafat |
| 028 Alnilam | 076 Deneb Kaitos | 124 Mirach | 172 Syrma |
| 029 Alnitak | 077 Denebola | 125 Mirfak | 173 Talitha |
| 030 Alphard | 078 Dubhe | 126 Mirzam | 174 Tania Australis |
| 031 Alphecca | 079 Edasich | 127 Mizar | 175 Tania Borealis |
| 032 Alpheratz | 080 Electra | 128 Muphrid | 176 Tarazed |
| 033 Alrakis | 081 Elnath | 129 Muscida | 177 Taygeta |
| 034 Alrescha | 082 Eltanin | 130 Nashira | 178 Thuban |
| 035 Alshain | 083 Enif | 131 Nekkar | 179 Unukalhai |
| 036 Altair | 084 Errai | 132 Nihal | 180 Vega |
| 037 Altais | 085 Fomalhaut | 133 Nunki | 181 Vindemiatrix |
| 038 Alterf | 086 Furud | 134 Nusakan | 182 Wasat |
| 039 Aludra | 087 Gacrux | 135 Peacock | 183 Wazn |
| 040 Alula Australis | 088 Giasar | 136 Phact | 184 Yed Posterior |
| 041 Alula Borealis | 089 Gienah | 137 Phecda | 185 Yed Prior |
| 042 Alya | 090 Gomeisa | 138 Pherkad | 186 Zaniah |
| 043 Ancha | 091 Graffias | 139 Pleione | 187 Zaurak |
| 044 Ankaa | 092 Groombridge 1830 | 140 Polaris | 188 Zavijava |
| 045 Antares | 093 Grumium | 141 Pollux | 189 Zosma |
| 046 Arcturus | 094 Hamal | 142 Porrima | 190 Zubenelgenubi |
| 047 Arkab | 095 Homan | 143 Procyon | 191 Zubeneshamali |
| 048 Arneb | 096 Izar | 144 Propus | |

Modern Constellations

for 8406

| No. | Constellation | Abbreviation |
|-----|------------------|--------------|
| 1 | Andromeda | And |
| 2 | Antlia | Ant |
| 3 | Apus | Aps |
| 4 | Aquarius | Aqr |
| 5 | Aquila | Aql |
| 6 | Ara | Ara |
| 7 | Aries | Ari |
| 8 | Auriga | Aur |
| 9 | Boötes | Boo |
| 10 | Caelum | Cae |
| 11 | Camelopardalis | Cam |
| 12 | Cancer | Cnc |
| 13 | Canes Venatici | CVn |
| 14 | Canis Major | CMa |
| 15 | Canis Minor | CMi |
| 16 | Capricornus | Cap |
| 17 | Carina | Car |
| 18 | Cassiopeia | Cas |
| 19 | Centaurus | Cen |
| 20 | Cepheus | Cep |
| 21 | Cetus | Cet |
| 22 | Chamaeleon | Cha |
| 23 | Circinus | Cir |
| 24 | Columba | Col |
| 25 | Coma Berenices | Com |
| 26 | Corona Australis | CrA |
| 27 | Corona Borealis | CrB |
| 28 | Corvus | Crv |
| 29 | Crater | Crt |
| 30 | Crux | Cru |
| 31 | Cygnus | Cyg |
| 32 | Delphinus | Del |
| 33 | Dorado | Dor |
| 34 | Draco | Dra |
| 35 | Equuleus | Equ |
| 36 | Eridanus | Eri |
| 37 | Fornax | For |
| 38 | Gemini | Gem |
| 39 | Grus | Gru |
| 40 | Hercules | Her |
| 41 | Horologium | Hor |
| 42 | Hydra | Hya |
| 43 | Hydrus | Hyi |
| 44 | Indus | Ind |

| No. | Constellation | Abbreviation |
|-----|---------------------|--------------|
| 45 | Lacerta | Lac |
| 46 | Leo | Leo |
| 47 | Leo Minor | LMi |
| 48 | Lepus | Lep |
| 49 | Libra | Lib |
| 50 | Lupus | Lup |
| 51 | Lynx | Lyn |
| 52 | Lyra | Lyr |
| 53 | Mensa | Men |
| 54 | Microscopium | Mic |
| 55 | Monoceros | Mon |
| 56 | Musca | Mus |
| 57 | Norma | Nor |
| 58 | Octans | Oct |
| 59 | Ophiuchus | Oph |
| 60 | Orion | Ori |
| 61 | Pavo | Pav |
| 62 | Pegasus | Peg |
| 63 | Perseus | Per |
| 64 | Phoenix | Phe |
| 65 | Pictor | Pic |
| 66 | Pisces | Psc |
| 67 | Piscis Austrinus | PsA |
| 68 | Puppis | Pup |
| 69 | Pyxis | Pyx |
| 70 | Reticulum | Ret |
| 71 | Sagitta | Sge |
| 72 | Sagittarius | Sgr |
| 73 | Scorpius | Sco |
| 74 | Sculptor | Scl |
| 75 | Scutum | Sct |
| 76 | Serpens | Ser |
| 77 | Sextans | Sex |
| 78 | Taurus | Tau |
| 79 | Telescopium | Tel |
| 80 | Triangulum | Tri |
| 81 | Triangulum Australe | TrA |
| 82 | Tucana | Tuc |
| 83 | Ursa Major | UMa |
| 84 | Ursa Minor | UMi |
| 85 | Vela | Vel |
| 86 | Virgo | Vir |
| 87 | Volans | Vol |
| 88 | Vulpecula | Vul |

GoToNova Deep Sky Object List for 8406

| ID No. | OBJECT | NGC # | Messier# | IC# | A(Abell) | U(UGC) | ID No. | OBJECT | NGC # | Messier# | IC# | A(Abell) | U(UGC) |
|--------|---------------------------|--------|----------|------|----------|--------|--------|--------------------------|-------|----------|------|----------|--------|
| 1 | Andromeda Galaxy | 224 | 31 | | | | 31 | Hind's Variable Nebula | 1555 | | | | |
| 2 | Barnards Galaxy | 6822 | | | | | 32 | Hubble's Variable Nebula | 2261 | | | | |
| 3 | Beehive Cluster | 2632 | 44 | | | | 33 | Integral Sign Galaxy | | | | | 3697 |
| 4 | Blackeye Galaxy | 4926 | 64 | | | | 34 | Jewel Box Cluster | 4755 | | | | |
| 5 | Blinking Planetary Nebula | 6826 | | | | | 35 | Keyhole Nebula | 3372 | | | | |
| 6 | Blue Flash Nebula | 6905 | | | | | 36 | Lagoon Nebula | 6523 | 8 | | | |
| 7 | Blue Planetary | 3918 | | | | | 37 | Little Gem | 6445 | | | | |
| 8 | Blue Snowball Nebula | 7662 | | | | | 38 | Little Gem Nebula | 6818 | | | | |
| 9 | Box Nebula | 6309 | | | | | 39 | Little Ghost Nebula | 6369 | | | | |
| 10 | Bubble Nebula | 7635 | | | | | 40 | North American Nebula | 7000 | | | | |
| 11 | Bipolar Nebula | 6302 | | | | | 41 | Omega Nebula | 6618 | 17 | | | |
| 12 | Butterfly Cluster | 6405 | 6 | | | | 42 | Orion Nebula | 1976 | 42 | | | |
| 13 | California Nebula | 1499 | | | | | 43 | Owl Nebula | 3587 | 97 | | | |
| 14 | Cat's Eye Nebula | 6543 | | | | | 44 | Pelican Nebula | | | 5070 | | |
| 15 | Cocoon Nebula | | | 5146 | | | 45 | Phantom Streak Nebula | 6741 | | | | |
| 16 | Cone Nebula | 2264 | | | | | 46 | Pinwheel Galaxy | 598 | 33 | | | |
| 17 | Cork Nebula | 650-51 | 76 | | | | 47 | Pleiades | | 45 | | | |
| 18 | Crab Nebula | 1952 | 1 | | | | 48 | Ring Nebula | 6720 | 57 | | | |
| 19 | Crescent Nebula | 6888 | | | | | 49 | Ring Tail Galaxy | 4038 | | | | |
| 20 | Draco Dwarf | | | | | 10822 | 50 | Rosette Nebula | 2237 | | | | |
| 21 | Duck Nebula | 2359 | | | | | 51 | Saturn Nebula | 7009 | | | | |
| 22 | Dumbbell Nebula | 6853 | 27 | | | | 52 | Sextans B Dwarf | | | | | 5373 |
| 23 | Eagle Nebula | | 16 | | | | 53 | Small Magellanic Cloud | 292 | | | | |
| 24 | Eight-Burst Nebula | 3132 | | | | | 54 | Sombrero Galaxy | 4594 | 104 | | | |
| 25 | Eskimo Nebula | 2392 | | | | | 55 | Spindle Galaxy | 3115 | | | | |
| 26 | Flaming Star Nebula | | | 405 | | | 56 | Tank Track Nebula | 2024 | | | | |
| 27 | Ghost of Jupiter | 3242 | | | | | 57 | Trifid Nebula | 6514 | 20 | | | |
| 28 | Great Cluster | 6205 | 13 | | | | 58 | Ursa Minor Dwarf | | | | | 9749 |
| 29 | Helix Nebula | 7293 | | | | | 59 | Whirlpool Galaxy | 5194 | 51 | | | |
| 30 | Hercules Galaxy Cluster | | | | 2151 | | 60 | Wild Duck Cluster | 6705 | 11 | | | |

GoToNova Double Star List

For 8406

| No. | Object | Const | Sep. | Magitude | SAO | Comm. Name |
|-----|--------|-------|------|------------|--------|---------------|
| 1 | Gam | And | 9.8 | 2.3 / 5.1 | 37734 | Almaak |
| 2 | Pi | And | 35.9 | 4.4 / 8.6 | 54033 | |
| 3 | Bet | Aql | 12.8 | 3.7 / 11 | 125235 | Alshain |
| 4 | 11 | Aql | 17.5 | 5.2 / 8.7 | 104308 | |
| 5 | 15 | Aql | 34 | 5.5 / 7.2 | 142996 | |
| 6 | E2489 | Aql | 8.2 | 5.6 / 8.6 | 104668 | |
| 7 | 57 | Aql | 36 | 5.8 / 6.5 | 143898 | |
| 8 | Zet | Aqr | 2.1 | 4.3 / 4.5 | 146108 | |
| 9 | 94 | Aqr | 12.7 | 5.3 / 7.3 | 165625 | |
| 10 | 41 | Aqr | 5.1 | 5.6 / 7.1 | 190986 | |
| 11 | 107 | Aqr | 6.6 | 5.7 / 6.7 | 165867 | |
| 12 | 12 | Aqr | 2.5 | 5.8 / 7.3 | 145065 | |
| 13 | Tau | Aqr | 23.7 | 5.8 / 9.0 | 165321 | |
| 14 | Gam | Ari | 7.8 | 4.8 / 4.8 | 92681 | Mesartim |
| 15 | Lam | Ari | 37.8 | 4.8 / 6.7 | 75051 | |
| 16 | The | Aur | 3.6 | 2.6 / 7.1 | 58636 | |
| 17 | Nu | Aur | 55 | 4.0 / 9.5 | 58502 | |
| 18 | Ome | Aur | 5.4 | 5.0 / 8.0 | 57548 | |
| 19 | Eps | Boo | 2.8 | 2.5 / 4.9 | 83500 | Izar |
| 20 | Del | Boo | 105 | 3.5 / 7.5 | 64589 | |
| 21 | Mu 1 | Boo | 108 | 4.3 / 6.5 | 64686 | Alkalurops |
| 22 | Tau | Boo | 4.8 | 4.5 / 11 | 100706 | |
| 23 | Kap | Boo | 13.4 | 4.6 / 6.6 | 29046 | |
| 24 | Xi | Boo | 6.6 | 4.7 / 6.9 | 101250 | |
| 25 | Pi | Boo | 5.6 | 4.9 / 5.8 | 101139 | |
| 26 | Iot | Boo | 38 | 4.9/7.5/13 | 29071 | |
| 27 | E1835 | Boo | 6.2 | 5.1 / 6.9 | 120426 | |
| 28 | 44 | Boo | 2.2 | 5.3 / 6.2 | 45357 | |
| 29 | | Cam | 2.4 | 4.2 / 8.5 | 24054 | |
| 30 | 32 | Cam | 21.6 | 5.3 / 5.8 | 2102 | |
| 31 | Alp 2 | Cap | 6.6 | 3.6 / 10 | 163427 | Secunda giedi |
| 32 | Alp 1 | Cap | 45 | 4.2 / 9.2 | 163422 | Prima giedi |
| 33 | Pi | Cap | 3.4 | 5.2 / 8.8 | 163592 | |
| 34 | Omi | Cap | 21 | 5.9 / 6.7 | 163625 | |
| 35 | Alp | Cas | 64.4 | 2.2 / 8.9 | 21609 | Shedir |
| 36 | Eta | Cas | 12.9 | 3.5 / 7.5 | 21732 | Achird |

| No. | Object | Const | Sep. | Magitude | SAO | Comm. Name |
|-----|--------|-------|------|-------------|--------|--------------|
| 37 | Iot | Cas | 2.3 | 4.7/7.0/8.2 | 12298 | |
| 38 | Psi | Cas | 25 | 4.7 / 8.9 | 11751 | |
| 39 | Sig | Cas | 3.1 | 5.0 / 7.1 | 35947 | |
| 40 | E3053 | Cas | 15.2 | 5.9 / 7.3 | 10937 | |
| 41 | 3 | Cen | 7.9 | 4.5 / 6.0 | 204916 | |
| 42 | Bet | Cep | 13.6 | 3.2 / 7.9 | 10057 | Alfirk |
| 43 | Del | Cep | 41 | 3.5 / 7.5 | 34508 | |
| 44 | Xi | Cep | 7.6 | 4.3 / 6.2 | 19827 | Al kurhah |
| 45 | Kap | Cep | 7.4 | 4.4 / 8.4 | 9665 | |
| 46 | Omi | Cep | 2.8 | 4.9 / 7.1 | 20554 | |
| 47 | E2840 | Cep | 18.3 | 5.5 / 7.3 | 33819 | |
| 48 | E2883 | Cep | 14.6 | 5.6 / 7.6 | 19922 | |
| 49 | Gam | Cet | 2.8 | 5.0 / 7.7 | 110707 | Kaffaljidhma |
| 50 | 37 | Cet | 50 | 5.2 / 8.7 | 129193 | |
| 51 | 66 | Cet | 16.5 | 5.7 / 7.5 | 129752 | |
| 52 | Eps | CMa | 7.5 | 1.5 / 7.4 | 172676 | Adhara |
| 53 | Tau | CMa | 8.2 | 4.4/10/11 | 173446 | |
| 54 | 145 | CMa | 25.8 | 4.8 / 6.8 | 173349 | |
| 55 | Mu | CMa | 2.8 | 5.0 / 7.0 | 152123 | |
| 56 | Nu 1 | CMa | 17.5 | 5.8 / 8.5 | 151694 | |
| 57 | Iot | Cnc | 30.5 | 4.2 / 6.6 | 80416 | |
| 58 | Alp | Cnc | 11 | 4.3 / 12 | 98267 | Acubens |
| 59 | Zet | Cnc | 6 | 5.1 / 6.2 | 97646 | |
| 60 | 24 | Com | 20.6 | 5.0 / 6.6 | 100160 | |
| 61 | 35 | Com | 1.2 | 5.1/7.2/9.1 | 82550 | |
| 62 | 2 | Com | 3.7 | 5.9 / 7.4 | 82123 | |
| 63 | Zet | CrB | 6.1 | 5.0 / 6.0 | 64833 | |
| 64 | Gam | Crt | 5.2 | 4.1 / 9.6 | 156661 | |
| 65 | Del | Crv | 24.2 | 3.0 / 9.2 | 157323 | Algorab |
| 66 | Alp | CVn | 19.4 | 2.9 / 5.5 | 63257 | Cor caroli |
| 67 | 25 | CVn | 1.8 | 5.0 / 6.9 | 63648 | |
| 68 | 2 | CVn | 11.4 | 5.8 / 8.1 | 44097 | |
| 69 | Gam | Cyg | 41 | 2.2 / 9.5 | 49528 | Sadr |
| 70 | Del | Cyg | 2.5 | 2.9 / 6.3 | 48796 | |
| 71 | Bet | Cyg | 34.4 | 3.1 / 5.1 | 87301 | Albireo |
| 72 | Omi 1 | Cyg | 107 | 3.8 / 6.7 | 49337 | |

| No. | Object | Const | Sep. | Magitude | SAO | Comm. Name |
|-----|--------|-------|------|-------------|--------|------------|
| 73 | 52 | Cyg | 6.1 | 4.2 / 9.4 | 70467 | |
| 74 | Ups | Cyg | 15.1 | 4.4 / 10 | 71173 | |
| 75 | Mu | Cyg | 1.9 | 4.7 / 6.1 | 89940 | |
| 76 | Psi | Cyg | 3.2 | 4.9 / 7.4 | 32114 | |
| 77 | 17 | Cyg | 26 | 5.0 / 9.2 | 68827 | |
| 78 | 61 | Cyg | 30.3 | 5.2 / 6.0 | 70919 | |
| 79 | 49 | Cyg | 2.7 | 5.7 / 7.8 | 70362 | |
| 80 | E2762 | Cyg | 3.4 | 5.8 / 7.8 | 70968 | |
| 81 | E2741 | Cyg | 1.9 | 5.9 / 7.2 | 33034 | |
| 82 | Gam | Del | 9.6 | 4.5 / 5.5 | 106476 | |
| 83 | Eta | Dra | 5.3 | 2.7 / 8.7 | 17074 | |
| 84 | Eps | Dra | 3.1 | 3.8 / 7.4 | 9540 | Tyl |
| 85 | 47 | Dra | 34 | 4.8 / 7.8 | 31219 | |
| 86 | Nu | Dra | 61.9 | 4.9 / 4.9 | 30450 | |
| 87 | Psi | Dra | 30.3 | 4.9 / 6.1 | 8890 | |
| 88 | 26 | Dra | 1.7 | 5.3 / 8.0 | 17546 | |
| 89 | 16&17 | Dra | 90 | 5.4/5.5/6.4 | 30012 | |
| 90 | Mu | Dra | 1.9 | 5.7 / 5.7 | 30239 | |
| 91 | 40/41 | Dra | 19.3 | 5.7 / 6.1 | 8994 | |
| 92 | 1 | Equ | 10.7 | 5.2 / 7.3 | 126428 | |
| 93 | The | Eri | 4.5 | 3.4 / 4.5 | 216114 | Acamar |
| 94 | Tau 4 | Eri | 5.7 | 3.7 / 10 | 168460 | |
| 95 | Omi 2 | Eri | 8.3 | 4.4/9.5/11 | 131063 | Keid |
| 96 | 32 | Eri | 6.8 | 4.8 / 6.1 | 130806 | |
| 97 | 39 | Eri | 6.4 | 5.0 / 8.0 | 149478 | |
| 98 | Alp | For | 5.1 | 4.0 / 6.6 | 168373 | Fornacis |
| 99 | Ome | For | 10.8 | 5.0 / 7.7 | 167882 | |
| 100 | Alp | Gem | 3.9 | 1.9 / 2.9 | 60198 | Castor |
| 101 | Del | Gem | 5.8 | 3.5 / 8.2 | 79294 | Wasat |
| 102 | Lam | Gem | 9.6 | 3.6 / 11 | 96746 | |
| 103 | Kap | Gem | 7.1 | 3.6 / 8.1 | 79653 | |
| 104 | Zet | Gem | 87 | 3.8/10/8.0 | 79031 | Mekbuda |
| 105 | 38 | Gem | 7.1 | 4.7 / 7.7 | 96265 | |
| 106 | Del | Her | 8.9 | 3.1 / 8.2 | 84951 | Sarin |
| 107 | Mu | Her | 34 | 3.4 / 9.8 | 85397 | |
| 108 | Alp | Her | 4.6 | 3.5 / 5.4 | 102680 | Rasalgethi |
| 109 | Gam | Her | 42 | 3.8 / 9.8 | 102107 | |
| 110 | Rho | Her | 4.1 | 4.6 / 5.6 | 66001 | |

| No. | Object | Const | Sep. | Magitude | SAO | Comm. Name |
|-----|--------|-------|------|-------------|--------|-------------|
| 111 | 95 | Her | 6.3 | 5.0 / 5.2 | 85647 | |
| 112 | Kap | Her | 27 | 5.0 / 6.2 | 101951 | |
| 113 | E2063 | Her | 16.4 | 5.7 / 8.2 | 46147 | |
| 114 | 100 | Her | 14.3 | 5.9 / 5.9 | 85753 | |
| 115 | 54 | Hya | 8.6 | 5.1 / 7.1 | 182855 | |
| 116 | HN69 | Hya | 10.1 | 5.9 / 6.8 | 181790 | |
| 117 | Eps | Hyd | 2.7 | 3.4 / 6.8 | 117112 | |
| 118 | The | Hyd | 29.4 | 3.9 / 10 | 117527 | |
| 119 | N | Hyd | 9.4 | 5.6 / 5.8 | 179968 | |
| 120 | | Lac | 28.4 | 4.5 / 10 | 72155 | |
| 121 | 8 | Lac | 22 | 5.7/6.5/10 | 72509 | |
| 122 | Gam 1 | Leo | 4.4 | 2.2 / 3.5 | 81298 | Algieba |
| 123 | lot | Leo | 1.7 | 4.0 / 6.7 | 99587 | |
| 124 | 54 | Leo | 6.6 | 4.3 / 6.3 | 81583 | |
| 125 | Gam | Lep | 96 | 3.7 / 6.3 | 170757 | |
| 126 | lot | Lep | 12.8 | 4.4 / 10 | 150223 | |
| 127 | Kap | Lep | 2.6 | 4.5 / 7.4 | 150239 | |
| 128 | h3752 | Lep | 3.2 | 5.4 / 6.6 | 170352 | |
| 129 | lot | Lib | 57.8 | 4.5 / 9.4 | 159090 | |
| 130 | | Lib | 23 | 5.7 / 8.0 | 183040 | |
| 131 | Mu | Lib | 1.8 | 5.8 / 6.7 | 158821 | |
| 132 | Eta | Lup | 15 | 3.6 / 7.8 | 207208 | |
| 133 | Xi | Lup | 10.4 | 5.3 / 5.8 | 207144 | |
| 134 | 38 | Lyn | 2.7 | 3.9 / 6.6 | 61391 | |
| 135 | 12 | Lyn | 1.7 | 5.4/6.0/7.3 | 25939 | |
| 136 | 19 | Lyn | 14.8 | 5.8 / 6.9 | 26312 | |
| 137 | Bet | Lyr | 46 | 3.4 / 8.6 | 67451 | Sheliak |
| 138 | Zet | Lyr | 44 | 4.3 / 5.9 | 67321 | |
| 139 | Eta | Lyr | 28.1 | 4.4 / 9.1 | 68010 | Aldafar |
| 140 | Eps | Lyr | 208 | 5.0 / 5.2 | 67310 | Double dbl |
| 141 | Eps 1 | Lyr | 2.6 | 5.0 / 6.1 | 67309 | Double dbl1 |
| 142 | Eps 2 | Lyr | 2.3 | 5.2 / 5.5 | 67315 | Double dbl2 |
| 143 | Alp | Mic | 20.5 | 5.0 / 10 | 212472 | |
| 144 | Zet | Mon | 32 | 4.3 / 10 | 135551 | |
| 145 | Eps | Mon | 13.4 | 4.5 / 6.5 | 113810 | |
| 146 | Bet | Mon | 7.3 | 4.7/4.8/6.1 | 133316 | |
| 147 | 15 | Mon | 2.8 | 4.7 / 7.5 | 114258 | |
| 148 | 70 | Oph | 4.5 | 4.0 / 5.9 | 123107 | |

| No. | Object | Const | Sep. | Magitude | SAO | Comm. Name |
|-----|--------|-------|------|-------------|--------|-----------------|
| 149 | 67 | Oph | 55 | 4.0 / 8.6 | 123013 | |
| 150 | Lam | Oph | 1.5 | 4.2 / 5.2 | 121658 | Marfic |
| 151 | Xi | Oph | 3.7 | 4.4 / 9.0 | 185296 | |
| 152 | 36 | Oph | 4.9 | 5.1 / 5.1 | 185198 | |
| 153 | Tau | Oph | 1.7 | 5.2 / 5.9 | 142050 | |
| 154 | Rho | Oph | 3.1 | 5.3 / 6.0 | 184382 | |
| 155 | 39 | Oph | 10.3 | 5.4 / 6.9 | 185238 | |
| 156 | Bet | Ori | 9.5 | 0.1 / 6.8 | 131907 | Rigel |
| 157 | Del | Ori | 53 | 2.2 / 6.3 | 132220 | Mintaka |
| 158 | lot | Ori | 11.3 | 2.8 / 6.9 | 132323 | Nair al saif |
| 159 | Lam | Ori | 4.4 | 3.6 / 5.5 | 112921 | Meissa |
| 160 | Sig | Ori | 13 | 3.8/7.2/6.5 | 132406 | |
| 161 | Rho | Ori | 7.1 | 4.5 / 8.3 | 112528 | |
| 162 | E747 | Ori | 36 | 4.8 / 5.7 | 132298 | |
| 163 | 1 | Peg | 36.3 | 4.1 / 8.2 | 107073 | |
| 164 | Eps | Per | 8.8 | 2.9 / 8.1 | 56840 | |
| 165 | Zet | Per | 12.9 | 2.9 / 9.5 | 56799 | Atik |
| 166 | Eta | Per | 28.3 | 3.3 / 8.5 | 23655 | Miram in becvar |
| 167 | The | Per | 18.3 | 4.1 / 10 | 38288 | |
| 168 | E331 | Per | 12.1 | 5.3 / 6.7 | 23765 | |
| 169 | Del | PsA | 5.1 | 4.2 / 9.2 | 214189 | |
| 170 | lot | PsA | 20 | 4.3 / 11 | 213258 | |
| 171 | Bet | PsA | 30.3 | 4.4 / 7.9 | 213883 | |
| 172 | Gam | PsA | 4.2 | 4.5 / 8.0 | 214153 | |
| 173 | Eta | PsA | 1.7 | 5.8 / 6.8 | 190822 | |
| 174 | Alp | Psc | 1.8 | 4.2 / 5.2 | 110291 | Alrishah |
| 175 | 55 | Psc | 6.5 | 5.4 / 8.7 | 74182 | |
| 176 | Psi | Psc | 30 | 5.6 / 5.8 | 74483 | |
| 177 | Zet | Psc | 23 | 5.6 / 6.5 | 109739 | |
| 178 | Kap | Pup | 9.9 | 4.5 / 4.7 | 174199 | |
| 179 | Eta | Pup | 9.6 | 5.8 / 5.9 | 174019 | |
| 180 | Eps | Scl | 4.7 | 5.4 / 8.6 | 167275 | |

| No. | Object | Const | Sep. | Magitude | SAO | Comm. Name |
|-----|--------|-------|------|-----------|--------|-----------------|
| 181 | Bet | Sco | 13.6 | 2.6 / 4.9 | 159682 | Graffias |
| 182 | Sig | Sco | 20 | 2.9 / 8.5 | 184336 | Alniyat |
| 183 | Nu | Sco | 41 | 4.2 / 6.1 | 159764 | Jabbah |
| 184 | 2 | Sco | 2.5 | 4.7 / 7.4 | 183896 | |
| 185 | | Sco | 23 | 5.4 / 6.9 | 207558 | |
| 186 | Hn39 | Sco | 5.4 | 5.9 / 6.9 | 184369 | |
| 187 | 12 | Sco | 3.9 | 5.9 / 7.9 | 184217 | |
| 188 | Bet | Ser | 31 | 3.7 / 9.0 | 101725 | |
| 189 | Del | Ser | 4.4 | 4.2 / 5.2 | 101624 | |
| 190 | Nu | Ser | 46 | 4.3 / 8.5 | 160479 | |
| 191 | The | Ser | 22.3 | 4.5 / 5.4 | 124070 | Alya |
| 192 | 59 | Ser | 3.8 | 5.3 / 7.6 | 123497 | |
| 193 | Zet | Sge | 8.5 | 5.0 / 8.8 | 105298 | |
| 194 | Eta | Sgr | 3.6 | 3.2 / 7.8 | 209957 | |
| 195 | | Sgr | 5.5 | 5.2 / 6.9 | 209553 | |
| 196 | Phi | Tau | 52 | 5.0 / 8.4 | 76558 | |
| 197 | Chi | Tau | 19.4 | 5.7 / 7.6 | 76573 | |
| 198 | 118 | Tau | 4.8 | 5.8 / 6.6 | 77201 | |
| 199 | 6 | Tri | 3.9 | 5.3 / 6.9 | 55347 | |
| 200 | Zet | UMa | 14 | 2.4 / 4.0 | 28737 | Mizar |
| 201 | Nu | UMa | 7.2 | 3.5 / 9.9 | 62486 | Alula borealis |
| 202 | 23 | UMa | 23 | 3.6 / 8.9 | 14908 | |
| 203 | Ups | UMa | 11.6 | 3.8 / 11 | 27401 | |
| 204 | Xi | UMa | 1.8 | 4.3 / 4.8 | 62484 | Alula australia |
| 205 | Sig 2 | UMa | 3.9 | 4.8 / 8.2 | 14788 | |
| 206 | 57 | UMa | 5.4 | 5.4 / 5.4 | 62572 | |
| 207 | Alp | UMi | 18.4 | 2.0 / 9.0 | 308 | Polaris |
| 208 | Gam | Vir | 1.4 | 3.5 / 3.5 | 138917 | Porrina |
| 209 | The | Vir | 7.1 | 4.4 / 9.4 | 139189 | |
| 210 | Phi | Vir | 4.8 | 4.8 / 9.3 | 139951 | |
| 211 | 84 | Vir | 2.9 | 5.7 / 7.9 | 120082 | |
| | | | | | | |

IOPTRON TWO YEAR TELESCOPE, MOUNT, AND CONTROLLER WARRANTY

A. iOptron warrants your telescope, mount, or controller to be free from defects in materials and workmanship for two years. iOptron will repair or replace such product or part which, upon inspection by iOptron, is found to be defective in materials or workmanship. As a condition to the obligation of iOptron to repair or replace such product, the product must be returned to iOptron together with proof-of-purchase satisfactory to iOptron.

B. The Proper Return Merchant Authorization Number must be obtained from iOptron in advance of return. Call iOptron at 1.781.569.0200 to receive the RMA number to be displayed on the outside of your shipping container. All returns must be accompanied by a written statement stating the name, address, and daytime telephone number of the owner, together with a brief description of any claimed defects. Parts or product for which replacement is made shall become the property of iOptron.

The customer shall be responsible for all costs of transportation and insurance, both to and from the factory of iOptron, and shall be required to prepay such costs.

iOptron shall use reasonable efforts to repair or replace any telescope, mount, or controller covered by this warranty within thirty days of receipt. In the event repair or replacement shall require more than thirty days, iOptron shall notify the customer accordingly. iOptron reserves the right to replace any product which has been discontinued from its product line with a new product of comparable value and function.

This warranty shall be void and of no force of effect in the event a covered product has been modified in design or function, or subjected to abuse, misuse, mishandling or unauthorized repair. Further, product malfunction or deterioration due to normal wear is not covered by this warranty.

IOPTRON DISCLAIMS ANY WARRANTIES, EXPRESS OR IMPLIED, WHETHER OF MERCHANTABILITY OF FITNESS FOR A PARTICULAR USE, EXCEPT AS EXPRESSLY SET FORTH HERE. THE SOLE OBLIGATION OF IOPTRON UNDER THIS LIMITED WARRANTY SHALL BE TO REPAIR OR REPLACE THE COVERED PRODUCT, IN ACCORDANCE WITH THE TERMS SET FORTH HERE. IOPTRON EXPRESSLY DISCLAIMS ANY LOST PROFITS, GENERAL, SPECIAL, INDIRECT OR CONSEQUENTIAL DAMAGES WHICH MAY RESULT FROM BREACH OF ANY WARRANTY, OR ARISING OUT OF THE USE OR INABILITY TO USE ANY IOPTRON PRODUCT. ANY WARRANTIES WHICH ARE IMPLIED AND WHICH CANNOT BE DISCLAIMED SHALL BE LIMITED IN DURATION TO A TERM OF TWO YEARS FROM THE DATE OF ORIGINAL RETAIL PURCHASE.

Some states do not allow the exclusion or limitation of incidental or consequential damages or limitation on how long an implied warranty lasts, so the above limitations and exclusions may not apply to you.

This warranty gives you specific legal rights, and you may also have other rights which vary from state to state.

iOptron reserves the right to modify or discontinue, without prior notice to you, any model or style telescope.

If warranty problems arise, or if you need assistance in using your telescope, mount, or controller contact:

iOptron Corporation
Customer Service Department
6E Gill Street
Woburn, MA 01801
www.ioptron.com
support@ioptron.com
Tel. (781)569-0200
Fax. (781)935-2860
Monday-Friday 9AM-5PM EST

NOTE: This warranty is valid to U.S.A. and Canadian customers who have purchased this product from an authorized iOptron dealer in the U.S.A. or Canada or directly from iOptron. Warranty outside the U.S.A. and Canada is valid only to customers who purchased from an iOptron Distributor or Authorized iOptron Dealer in the specific country. Please contact them for any warranty

Free Manuals Download Website

<http://myh66.com>

<http://usermanuals.us>

<http://www.somanuals.com>

<http://www.4manuals.cc>

<http://www.manual-lib.com>

<http://www.404manual.com>

<http://www.luxmanual.com>

<http://aubethermostatmanual.com>

Golf course search by state

<http://golfingnear.com>

Email search by domain

<http://emailbydomain.com>

Auto manuals search

<http://auto.somanuals.com>

TV manuals search

<http://tv.somanuals.com>