



**JL AUDIO 500/5**  
five-channel system amplifier  

---

owner's manual

*Thank you for purchasing a JL Audio amplifier for  
your automotive sound system.*

*Your amplifier has been designed and manufactured to exacting standards in order to ensure years of musical enjoyment in your vehicle. For maximum performance and extended warranty coverage, we highly recommend that you have your new amplifier installed by an authorized JL Audio dealer. Your authorized dealer has the training, expertise and installation equipment to ensure optimum performance from this product. Should you decide to install the amplifier yourself, please take the time to read this manual thoroughly so as to familiarize yourself with its installation requirements and setup procedures.*

*If you have any questions regarding the instructions in this manual or any aspect of your amplifier's operation, please contact your authorized JL Audio dealer for assistance. If you need further assistance, please call the JL Audio Technical Support Department at (954) 443-1100 during business hours (Eastern Time Zone).*



## PROTECT YOUR HEARING!

We value you as a long-term customer. For that reason, we urge you to practice restraint in the operation of this product so as not to damage your hearing and that of others in your vehicle. Studies have shown that continuous exposure to high sound pressure levels can lead to permanent (irreparable) hearing loss. This and all other high-power amplifiers are capable of producing such high sound pressure levels when connected to a speaker system. Please limit your continuous exposure to high volume levels.

While driving, operate your audio system in a manner that still allows you to hear necessary noises to operate your vehicle safely (horns, sirens, etc.).

## SERIAL NUMBER

In the event that your amplifier requires service or is ever stolen, you will need to have a record of the product's serial number. Please take the time to enter that number in the space provided below. The serial number can be found on the bottom panel of the amplifier and on the amplifier packaging.

Serial Number:

---

## INSTALLATION APPLICATIONS

This amplifier is designed for operation in vehicles with 12V, negative-ground electrical systems. Use of this product in vehicles with positive ground and/or voltages other than 12V may result in damage to the product and will void the warranty.

This product is **not** certified or approved for use in aircraft.

Do not attempt to "bridge" the outputs of this amplifier with the outputs of a second amplifier; including an identical one.

## PLANNING YOUR INSTALLATION

It is important that you take the time to read this manual and that you plan out your installation carefully. The following are some considerations that you must take into account when planning your installation.

### Cooling Efficiency Considerations:

Your JL Audio amplifier employs an advanced type of heat management, called RealSink™. This feature takes advantage of convection and radiation effects to remove heat from the amplifier circuitry. For optimum cooling performance, the vertical heat sinks located at the back of the amplifier should be exposed to as large a volume of air as possible. Enclosing the amplifier in a small, poorly ventilated chamber can lead to excessive heat build-up and degraded performance. If an installation calls for an enclosure around the amplifier, we recommend that this enclosure be ventilated with the aid of a fan. In normal applications, fan-cooling is not necessary, but you still need to follow some basic guidelines:

- Amplifier mounted vertically with heat sink fins pointing up: Optimum
- Amplifier mounted horizontally, right side up: Good
- Amplifier mounted horizontally, but upside down: Fair (not recommended if there is less than 1 inch (2.5 cm) clearance above the amplifier heat sinks)
- Amplifier mounted vertically with heat sink fins pointing laterally: Fair
- Amplifier mounted vertically with heat sink fins pointing down: Poor (not recommended)

If mounting the amplifier under a seat, make sure there is at least 1 inch (2.5 cm) of space above the amplifier heat sink fins to permit proper cooling.

### Safety Considerations:

Your amplifier needs to be installed in a dry, well-ventilated environment and in a manner which does not interfere with your vehicle's safety equipment (air bags, seat belt systems, ABS brake systems, etc.). You should also take the time to securely mount the amplifier using the supplied screws so that it does not come loose in the event of a collision or a sudden jolt to the vehicle (20 lbs. of aluminum traveling at 60 MPH will hurt you).

### Stupid Mistakes to Avoid:

- Check before drilling any holes in your vehicle to make sure that you will not be drilling through a gas tank, brake line, wiring harness or other vital vehicle system.
- Do not run system wiring outside or underneath the vehicle. This is an extremely dangerous practice which can result in severe damage to your vehicle and person.
- Protect all system wires from sharp metal edges and wear by carefully routing them, tying them down and using grommets and loom where appropriate.
- Do not mount the amplifier in the engine compartment, under the vehicle, on the roof or in any other area that will expose the amplifier circuitry to the elements.

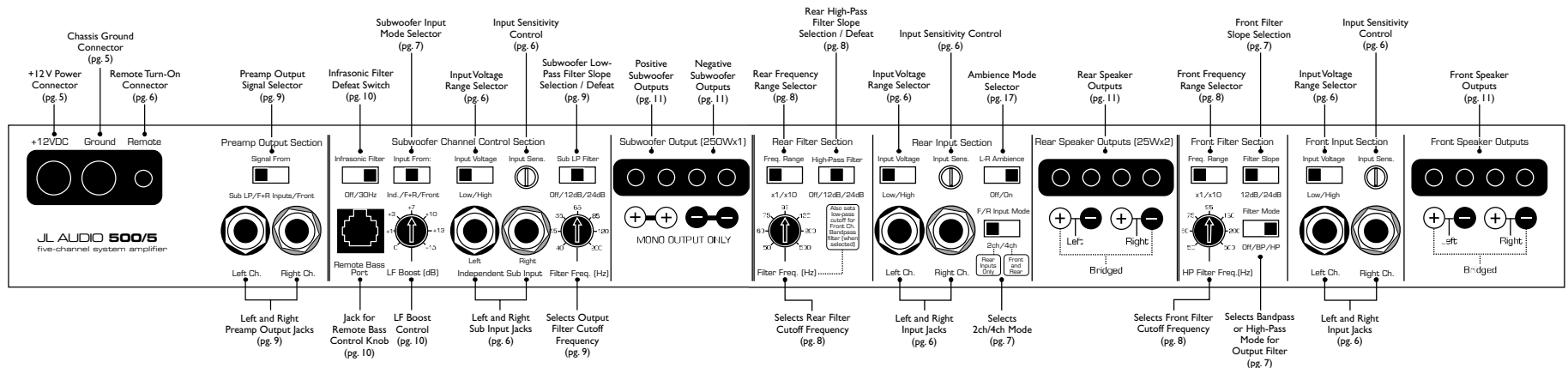

## PRODUCT DESCRIPTION

The JL Audio 500/5 is a five-channel system amplifier utilizing patented Absolute Symmetry™ Class AB technology for its front and rear channels and patented Class D technology for its subwoofer channel. Front and subwoofer channels benefit from JL Audio's exclusive R.I.P.S. power supply design which optimizes the output of each section for any impedance between 1.5 and 4 ohms per channel.

The staggered power distribution of the front and rear channel pairs (100W × 2 for front and 25 × 2 for rear) allows for a wide variety of application options. The 500/5 can be operated in the following modes:

1) As a full-system amplifier in bi-amp mode with its subwoofer channel driving subwoofers in low-pass mode (250W × 1), front channels driving front component speakers (100W × 2) in high-pass mode and rear channels driving rear component speakers in high-pass mode (25W × 2).

2) As a full-system amplifier in a tri-amplified system, delivering band-passed signals through its front channels to mid-bass/mid-range speakers and high-passed signals through its front channels to tweeters.

The 500/5's flexible input and crossover sections permit operation with a wide variety of source units and system configurations. The 500/5 can operate with a single pair of stereo inputs or with separate inputs for front and rear channel pairs, if the source unit is equipped with front and rear outputs. The subwoofer channel can be driven with a discrete signal from a source unit's subwoofer output or can receive its signal from the front and/or rear channel inputs.

The 500/5's preamp output can send pass-through signals from the front inputs only, the subwoofer inputs only **OR** a sum of the front and rear input signals. This allows the connection of additional subwoofer amplifier(s) or full-range amplifiers.

## TYPICAL INSTALLATION SEQUENCE

The following represents the sequence for a typical amplifier installation, using an aftermarket source unit. Additional steps and different procedures may be required in some applications. If you have any questions, please contact your authorized JL Audio dealer for assistance.

1) Disconnect the negative battery post connection and secure the disconnected cable to prevent accidental re-connection during installation.

**This step is not optional!**

2) Run power wire (minimum 4 AWG) from the battery location to the amplifier mounting location, taking care to route it in such a way that it will not be damaged and will not interfere with vehicle operation. Use 2 AWG or 1/0 AWG power wire if additional amplifiers are being installed with the 500/5.

3) Connect power wire to the positive battery post. Fuse the wire with an appropriate fuse block (and connectors) within 18 inches (45 cm) wire length of the positive battery post. **This fuse is essential to protect the vehicle. Do not install the fuse until the power wire has been connected to the amplifier.**

4) Run signal cables (RCA cables) and remote turn-on wire from the source unit to the amplifier mounting location. There are several ways to provide input to the 500/5. Please read the rest of this manual carefully to choose the best one for your system.

5) Run speaker wire from the speaker systems to the amplifier mounting location.

6) Find a good, solid metal grounding point close to the amplifier and connect the negative power wire to it using appropriate hardware. Use 4 AWG power wire, no longer than 36 inches (90 cm) from the amplifier to the ground connection point. In some vehicles, it may be necessary to upgrade the battery ground wire. (See page 5 for important notice).

7) Securely mount the amplifier using the supplied screws.

8) Connect the positive and negative power wires to the amplifier. A fuse near the amplifier is not necessary.

9) Connect the remote turn-on wire to the amplifier.

10) Connect the RCA input cables to the amplifier.

11) Connect the speaker wires to the amplifier.

12) Carefully review the amplifier's control settings to make sure that they are set according to the needs of the system.

13) Install power wire fuse (50A for a single 500/5) and reconnect the negative battery post terminal.

14) Turn on the source unit at a low level to double-check that the amplifier is configured correctly. Resist the temptation to crank it up until you have verified the control settings.

15) Make necessary adjustments to the input sensitivity controls of the subwoofer channel and front and rear channel pairs to obtain the right overall output and the desired balance between their outputs. See Appendix B (page 22) for the recommended input sensitivity setting method.

16) Enjoy the fruits of your labor with your favorite music.

## POWER CONNECTIONS

Before installing the amplifier, disconnect the negative (ground) wire from the vehicle's battery. This will prevent accidental damage to the system, the vehicle and your body during installation.

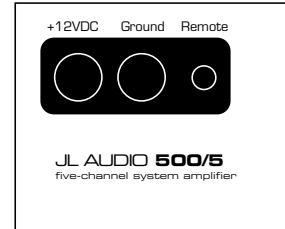

The 500/5's "+12VDC" and "Ground" connections are designed to accept 4 AWG power wire. **4 AWG is the only recommended power wire size for this amplifier.**

If you are installing the 500/5 with other amplifiers and wish to use a single main power wire, use 2 AWG or 1/0 AWG main power wire (depending on the overall current demands of all the amplifiers in the system). This 2 AWG or 1/0 AWG power wire should terminate into a distribution block mounted as close to the amplifiers as possible and should connect to the 500/5 with 4 AWG power wire.

Please note that smaller AWG numbers mean bigger wire and vice-versa (1/0 AWG is biggest, 2 AWG is smaller; then 4 AWG, then 8 AWG, etc.).

To connect the power wires to the amplifier, first back out the set screw on the top of the amplifier, using the supplied 2.5 mm hex wrench. Strip 1/2 inch (12 mm) of insulation from the end of each wire and insert the bare wire into the receptacle on the front panel of the amplifier; seating it firmly so that no bare wire is exposed. While holding the wire in place, tighten the set screw firmly, taking care not to strip the head of the screw.

The ground connection should be made using the same gauge wire as the power connection (4 AWG) and should be kept as short as possible, while accessing a solid piece of sheet metal in the vehicle. The surface of the sheet metal should be sanded at the contact point to create a clean, metal-to-metal connection between the chassis and the termination of the ground wire. The use of a star washer to lock down the connection is advisable.

Any wires run through metal barriers (such as firewalls), must be protected with a high quality rubber grommet to prevent damage to the insulation of the wire. Failure to do so may result in a dangerous short circuit.

## ! IMPORTANT

Many vehicles employ small (10 AWG - 6 AWG) wire to ground the battery to the vehicle chassis and to connect the alternator's positive connection to the battery. To prevent voltage drops, these wires should be upgraded to 4 AWG when installing amplifier systems with main fuse ratings above 60A.

## FUSE REQUIREMENTS

It is absolutely vital that the main power wire(s) to the amplifier(s) in the system be fused within 18 inches (45 cm) of the positive battery post connection. The fuse value at each power wire should be high enough for all of the equipment being run from that power wire. If only the 500/5 is being run from that power wire, we recommend a 50A fuse be used. AGU (big glass fuse) or MaxiFuse™ (big plastic-body fuse) types are recommended.

No fuse is required or recommended directly before the amplifier power connection. If one is desired, we recommend the use of a 50A AGU fuse or MaxiFuse™ type.

## TURN-ON LEAD

The 500/5 uses a conventional +12V remote turn-on lead, typically controlled by the source unit's remote turn-on output. The amplifier will turn on when +12V is present at its "Remote" input and turn off when +12V is switched off. If a source unit does not have a dedicated remote turn-on output, the amplifier's turn-on lead can be connected to +12V via a switch that derives power from an ignition-switched circuit.

The 500/5's "Remote" turn-on connector is designed to accept 18 AWG – 8 AWG wire. 12 AWG is more than adequate for this purpose. To connect the remote turn-on wire to the amplifier, first back out the set screw on the top of the amplifier, using the supplied hex wrench. Strip 1/2 inch (12mm) of wire and insert the bare wire into the receptacle on the front panel of the amplifier, seating it firmly so that no bare wire is exposed. When using smaller wire, it may be necessary to strip 1 inch of insulation from the wire and fold the bare wire in half prior to insertion. While holding the wire in the terminal, tighten the set screw firmly, taking care not to strip the head of the screw and making sure that the wire is firmly gripped by the set screw.

## INPUT SECTIONS

Three left/right pairs of RCA type jacks are provided for input (one pair for the subwoofer channel, one pair for the rear channels and one pair for the front channels). There are several ways that the 500/5's inputs can be configured. Please read the "System Configurations" section of this manual (page 14) carefully to determine the proper configuration for your application.

### Input Voltage Range:

A wide range of signal input voltages can be accommodated by each of the 500/5's input stages (200mV – 8V). This wide range is split up into two sub-ranges, accessible via switches located in each input section of the amplifier. **Be aware that each input section's "Input Voltage" switch will have to be configured, regardless of how many inputs are actually feeding the amplifier.**

The "Low" position on each "Input Voltage" switch selects an input sensitivity range between 200mV and 2V. This means that the Input Sensitivity

rotary control will operate within that window. If you are using an aftermarket source unit, with conventional preamp-level outputs, this is most likely the position that you will use.

The "High" position on each "Input Voltage" switch selects an input sensitivity range between 800mV and 8V. This is useful for certain high-output preamp level signals as well as speaker-level output from source units and small amplifiers. To use speaker-level sources, splice the speaker output wires of the source unit or small amplifier onto a pair of RCA plugs.

### ! IMPORTANT

The output of the amplifier will **decrease** for a given input voltage when the "Input Range" switch is placed in the "High" position. Conversely, the output will be higher with the switch in the "Low" position. While this may sound counter-intuitive, it is consistent with the descriptions above.

### Input Sensitivity Adjustment:

Located next to the "Input Voltage" switch in each input section is a rotary control labeled "Input Sens." Once the appropriate "Input Voltage" range has been selected, this control can be used to match up the signal level of the system to produce the desired level from the amplifier. Rotating the control clockwise will result in higher sensitivity (louder for a given input voltage). Rotating the control counter-clockwise will result in lower sensitivity (quieter for a given input voltage.) Be aware that each of the three "Input Sens." adjustments will have to be made, regardless of how many inputs are feeding the amplifier. These controls will allow you to set the appropriate relative levels for the subwoofer channels and the front and rear channels.

### ! IMPORTANT

To properly set each set of amplifier channels for maximum clean output, please refer to Appendix B (page 22) in this manual. After using this procedure, you can then adjust the relative level of each channel pair by adjusting the input sensitivity **downward** on either or both channel pairs, if they require attenuation to achieve the desired system balance.

**Do not increase the "Input Sens." setting for**

**any amplifier in the system beyond the maximum level established during the procedure outlined in Appendix B (page 22). Doing so will result in audible distortion and possible speaker damage.**

Be aware that all three "Input Sens." adjustments will have to be made, regardless of how many input cables are feeding the amplifier. These controls will allow you to set the appropriate relative levels for the Front, Rear and Subwoofer Channels.

### Subwoofer "Input From" Selection:

Located to the left of the "Input Voltage" switch in the "Subwoofer Channel Control Section" is a switch labeled "Input From". This switch determines whether the subwoofer channel will receive its input from the "Independent Sub Input" jacks (select "Ind.") or from a sum of the Front and Rear Channel Input signals (select "F+R") or from the Front Channel Inputs only (select "Front").

### Front and Rear Channel "Input Mode" Selection:

Located to the right of the rear channel input jacks in the "Rear Input Section" is a switch labeled "F/R Input Mode". This switch determines whether the front and rear channels will receive their input independently (select "4ch") or from the "Rear Input Section" jacks only (select "2ch").

## CROSSOVER CONTROLS

Crossovers are groups of individual electronic filters which allow only certain frequency ranges to pass through them by attenuating frequencies outside the selected range. These filters allow the user to specify what frequency range will be sent out of each channel section of the amplifier. This, in turn, allows each speaker system to only reproduce a range of frequencies it is well-suited for, resulting in reduced distortion and improved fidelity.

### Front Filter Section:

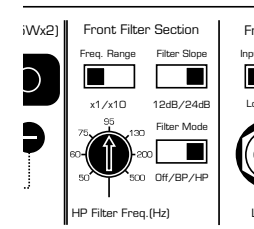

1) "Filter Mode" Control: Located in the "Front Filter Section", this switch allows you to configure the Front Channel filter into one of three modes:

"Off" (Defeated): Defeats the filter for the Front Channels completely, allowing the full range of frequencies present at the inputs to feed that pair of channels. This is useful for systems utilizing outboard crossovers or requiring full-range reproduction from these channels.

"BP" (Bandpass): Configures the Front Channel Filter to attenuate frequencies above the selected filter frequency **and** below the frequency selected in the Rear Channel High-Pass Filter. This creates a true bandpass filter well-suited for driving mid-bass or mid-range speakers in a tri-amplified system (see page 18 for details).

"HP" (High-Pass): Configures the Front Channel Filter to attenuate frequencies below the selected filter frequency. Useful for connection of component speakers to the front channels in a bi-amplified system.

2) "Filter Slope" Control: This switch allows you to select from two filter slopes.

"12dB": Configures the Front Channel Filter to attenuate frequencies below the selected filter frequency at a rate of 12 dB per octave (Butterworth alignment).

"24dB": Configures the Front Channel Filter to attenuate frequencies below the selected filter frequency at a rate of 24 dB per octave (Linkwitz-Riley alignment).

Depending on the speaker system and the vehicle, different filter slopes may be required to produce a smooth transition between the sound of different speakers in the system. Experiment to find the slope which best matches the acoustic requirements of the system. The sharper “24dB” setting will do a better job of protecting small speakers with limited power handling. The shallower “12dB” octave setting allows the front speakers to reproduce more content below the cutoff frequency.

**3) “Freq. Range” Control:** When thrown to the right, this switch multiplies the cutoff frequency selected by the rotary “Filter Freq. (Hz)” control by a factor of 10. In the “x1” position, the range of the rotary control is 50 - 500 Hz (as marked). In the “x10” position, the range of the rotary control is 500 Hz - 5 kHz (5000 Hz).

**4) “Filter Freq. (Hz)”** The filter frequency markings surrounding this rotary control are for reference purposes and are generally accurate to within 1/3 octave or better. If you would like to select the filter cutoff frequency with a higher level of precision, consult the charts in Appendix A (page 20) of this manual.

#### Rear Filter Section:

The rear channels of the 500/5 can be operated through the amplifier’s built-in rear high-pass filter. This attenuates frequencies below the one selected by the “Filter Freq.” control in the Rear Filter Section.

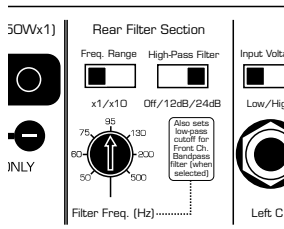

**1) “High-Pass Filter” Control:** This switch allows you to defeat the Rear Channel Filter or select from two different filter slopes.

“Off”: Defeats the filter completely, allowing the full range of frequencies present at the inputs to feed that pair of channels. This is useful for systems utilizing outboard crossovers or requiring full-range reproduction from these channels.

“12dB”: Configures the filter for that pair of channels to attenuate frequencies below the selected filter frequency at a rate of 12dB per octave (Butterworth alignment).

“24dB”: Configures the filter for that pair of channels to attenuate frequencies below the selected filter frequency at a rate of 24dB per octave (Linkwitz-Riley alignment).

Depending on the speaker system and the vehicle, different filter slopes may be required to produce a smooth transition between the speakers in the system. Experiment to find the slope which best matches the acoustic requirements of your system. The sharper “24dB” setting will do a better job of protecting small speakers with limited power handling. The shallower “12dB” octave setting allows the rear speakers to reproduce more low-frequency content.

If you are using the 500/5 in tri-amp mode, these rear filter controls will determine the tweeter crossover frequency and slope. We recommend that you use the sharper “24dB” position for most tweeters.

**2) “Freq. Range” Control:** When thrown to the right, this switch multiplies the cutoff frequency selected by the rotary “Filter Freq. (Hz)” control by a factor of 10. In the “x1” position, the range of the rotary control is 50 - 500 Hz (as marked). In the “x10” position, the range of the rotary control is 500 Hz - 5 kHz (5000 Hz).

**3) “Filter Freq. (Hz)”** The filter frequency markings surrounding this rotary control are for reference purposes and are generally accurate to within 1/3 octave or better. If you would like to select the filter cutoff frequency with a higher level of precision, consult “Chart A1” in Appendix A (page 20) of this manual.

#### Subwoofer Channel Filter:

The 500/5’s subwoofer channel filter (located in the “Subwoofer Channel Control Section” employs an advanced state-variable, low-pass active filter. This feature is designed to attenuate frequencies above its filter frequency, so that the system’s subwoofers do not reproduce any audible midrange content. The low-pass filter in the 500/5 is fully variable between 40 Hz and 200 Hz via the “Filter Freq.” control knob and features the ability to select between a moderate “12dB” per octave or a steep “24dB” per octave slope.

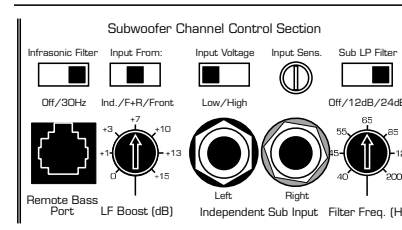

**1) “Sub LP Filter”:** This switch, located in the Subwoofer Channel Control Section, configures the low-pass filter for the subwoofer channel into one of three modes.

“Off”: Defeats the filter for the subwoofer channels completely, allowing the full range of frequencies present at the input to feed the sub channel. This is useful for systems utilizing outboard crossovers. Keep in mind that defeating the “Sub LP Filter” also defeats the “LF Boost” and “Infrasonic Filter”. With the “Sub LP Filter” defeated (“Off”), the subwoofer channel’s upper frequency response limit is 500 Hz, due to its bass-specific Class D design.

“12dB”: Configures the filter for the subwoofer channel to attenuate frequencies above the selected filter frequency at a rate of 12 dB per octave (Butterworth alignment).

“24dB”: Configures the filter for the subwoofer channel to attenuate frequencies above the selected filter frequency at a rate of 24 dB per octave (Linkwitz-Riley alignment).

Depending on the subwoofer system and the vehicle, different slopes may be required to produce a smooth transition to the midbass speakers in the system. Experiment to find the slope which best matches the acoustic requirements of your system.

**Hint:** A trunk mounted sub whose output has to “fight” through a rear deck or a back seat often

benefits from the 12 dB per octave slope which lets more upper bass content pass through. A sub that fires directly into the listening environment is more likely to benefit from a 24 dB per octave slope.

The above hint is not a “set-in-stone” rule... You should always listen to the system carefully to determine the best choice as vehicle acoustics and other factors play a big role in choosing the most appropriate filter slope.

**2) “Filter Freq. (Hz)”** The filter frequency markings surrounding this rotary control are for reference purposes and are generally accurate to within 1/3 octave or better. If you would like to select the filter cutoff frequency with a higher level of precision, consult “Chart A2” in Appendix A of this manual (page 20).

#### PREAMP OUTPUT SECTION

The 500/5 incorporates a flexible preamp output section, permitting additional amplifiers to be added to the system. This pre-amp output can be configured three different ways using the switch labeled “Signal From” in the “Preamp Output Section”.

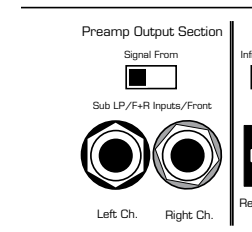

**1) “Sub LP”:** The preamp output delivers the same mono-summed signal that is feeding the 500/5’s subwoofer channel when the “Sub LP” mode is engaged, including all the low-pass filtering, “LF Boost” and “Infrasonic Filter” processing that is selected. This mode is useful for feeding an additional (slave) subwoofer amplifier (the JL Audio 250/1 matches the 500/5’s subwoofer channel perfectly). For more information on adding additional subwoofer amplifiers in master / slave mode, please refer to Appendix C on page 24.

**2) “F+R Inputs” (Front + Rear):** This is a pass-through mode for the preamp output, delivering a sum of the signals being fed to the “Front Input Section” and “Rear Input Section” of the amplifier (If the input signal is full-range, the preamp output

will be full-range.) This signal is not affected by the “LF Boost” or “Infrasonic Filter” processing selected for the amplifier. When the 500/5 is being used to drive front, rear and subwoofer speaker systems, this preamp output mode will deliver a summed front/rear signal to an additional subwoofer amplifier, while permitting fading of the front and rear speaker systems from the source unit.

3) “Front”: This is a pass-through mode for the preamp output, delivering the same signal that is being fed to the “Front Input Section” of the amplifier (If the input signal is full-range, the preamp output will be full-range.) This signal is not affected by the “LF Boost” or “Infrasonic Filter” processing selected for the amplifier.

### !! CAUTION

If the “Output Mode” switch is in the “Sub LP” position and the “Sub LP Filter” switch is in the “Off” position, the preamp output will be a 12dB/octave low-pass with the “Bass Control” processing added to it. **THIS IS NOT A PREFERRED OPERATING MODE. DO NOT USE THIS MODE FOR MASTER / SLAVE CONFIGURATIONS.**

Note: The signal level of the “Preamp Output” is affected by the setting of the “Input Voltage” switches (of the input section(s) chosen by the “Signal From” switch). See the “Input Voltage Range” section (page 6) for details on input voltage settings. The preamp output level is not affected by the “Input Sens.” rotary controls.

## BASS PROCESSING

The 500/5’s subwoofer channel control section also includes some basic bass processing tools. These consist of two primary components: a fixed-frequency, 24 dB / octave infrasonic filter and a fixed-frequency / “Q”, single-band equalizer centered at 48 Hz.

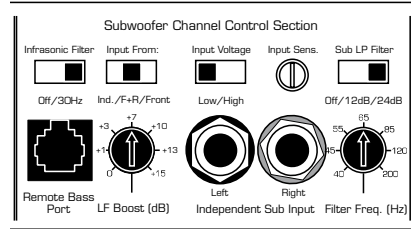

1) “Infrasonic Filter”: The infrasonic filter is a 24 dB / octave high-pass filter, with a fixed cutoff frequency of 30 Hz. This filter is designed to conserve amplifier power and protect subwoofer systems without audibly degrading the sub-bass output. With ported enclosures, the use of the infrasonic filter is highly recommended to protect the speaker(s) from excessive excursion below box tuning. With sealed enclosures, the use of the filter is less necessary, but can still help protect the speaker system. The infrasonic filter can be completely defeated by selecting the “Off” position on the “Infrasonic Filter” switch. This bypasses all signal from flowing through the circuit.

2) LF (Low-frequency) Boost: This feature allows the user to control the boost of a fixed “Q”, fixed-frequency equalization band centered at 48 Hz. The “LF Boost” rotary control determines how much boost (in dB) you are adding to the bass signal. A range of 0-15 dB of boost is available. If no boost is desired, rotate the “LF Boost” control fully counterclockwise.

The “Remote Bass Port” allows the connection of an optional remote boost knob (the RBC-1) that can be mounted in the front of the vehicle. This optional control takes the place of the “LF Boost” knob on the amplifier when connected and bypasses the “LF Boost” rotary control on the amplifier.

### !! IMPORTANT

The “LF Boost” and “Infrasonic Filter” features will only operate when the subwoofer channel’s filter is activated with the “Sub LP Filter” switch in

the “12dB” or “24dB” position. These features will not work with the “Sub LP Filter” switch in the “Off” position. This is to prevent cascading the processing of multiple amplifiers when configured in a master / slave arrangement. If you are using an external active crossover and would like to use the “LF Boost” and “Infrasonic Filter” features, set the “Amp LP Filter” switch on “12dB” and rotate the frequency selection knob fully clockwise to the “200 Hz” position. This will activate the bass processing features without significantly affecting the crossover point selected by the external active crossover.

## SPEAKER OUTPUTS

The 500/5 employs JL Audio’s exclusive Regulated, Intelligent Power Supply (R.I.P.S.) design on its front and subwoofer channels. The operation of the R.I.P.S. system is independent for each pair of channels. This sophisticated power supply allows the amplifier to produce its optimum power (100 watts x 2 for the front channels and 250 W x 1 for the subwoofer channel over a wide range of speaker impedances. Unlike conventional amplifiers that require a specific impedance to produce optimum power, the R.I.P.S.-equipped 500/5 gives you the freedom to use a variety of speaker configurations that achieve final nominal impedances between 1.5 – 4Ω per channel (without sacrificing power output or sound quality). When bridged, the front channel pair will optimize output between 3 – 8Ω. The rear channel pair will optimize output between 6 - 8Ω.

The operation of the R.I.P.S. circuitry is entirely automatic and adjusts itself every time the amplifier is turned on according to the lowest impedance present at the speaker load. There are no user controls to configure. The system operates through multiple stages of impedance optimization, choosing the stage most appropriate to the actual impedance of the speakers you connect to it.

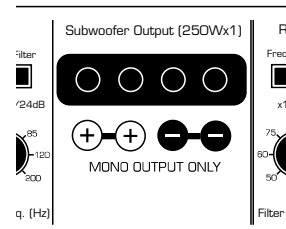

### !! IMPORTANT

If you connect a load higher than 4Ω nominal per channel (or 8Ω in bridged mode for the front and rear channels), power will drop by half with every doubling of impedance above 4Ω stereo / 8Ω mono. If you connect a load lower than 1.5Ω nominal per channel, the amplifier protection circuitry activates a “safe” mode which reduces amplifier power to protect the circuitry from failure (the yellow “Low Ω” LED lights to indicate that this has happened). See page 12 for details.

Speaker loads below 1.5Ω nominal per channel are not recommended and may cause the amplifier output to distort excessively.

### !! IMPORTANT

The rear channels of the 500/5 do not employ R.I.P.S. optimization and are designed to deliver rated power into loads between 3 and 4Ω per channel. Operating the rear channels below 3Ω may result in excessive distortion and/or shutting down of these channels and is not recommended.

## BRIDGING CONSIDERATIONS

Bridging is the practice of combining the output of two amplifier channels to drive a single load. When bridged, each channel produces signals of equal magnitude, but opposite polarity. The combined output of the two channels provides twice the output voltage available from a single channel. The 500/5 has been designed for bridging of its front and rear channel pairs without the need for input inversion adaptors.

### !! IMPORTANT

Operating bridged channel pairs into a load lower than 3Ω is not recommended.

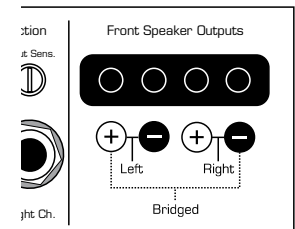

To bridge a pair of channels, use the “Left +” and “Right -” speaker connectors only (the “Left -” and “Right +” remain unused). Then connect a mono signal to both left and right RCA inputs for

that channel pair. This requires an RCA “Y-adaptor” (not included.) Connection of only one RCA input will result in reduced power output, increased distortion and can cause the amplifier to overheat.

**Do not do this!** Instead, use a “Y-adaptor” to split the mono signal into both left and right RCA inputs.

**Why a mono signal?** If you are bridging a pair of channels and use a stereo input, the only information that will reach the amplifier stage is the common-phase portion of the signal. This may be useful for passively deriving a center-channel signal, but is not going to give you a defined left or right channel. If you are looking to reproduce a single channel's signal, you must split the mono signal with a “Y-adaptor” and connect it to both left and right RCA inputs for the bridged channel pair.

## **STATUS INDICATOR LIGHTS / PROTECTION CIRCUITRY**

There are three status indicator lights on the top of the amplifier. These are as follows:

1) **“Power” (Green):** lights to indicate that the amplifier is turned on and operating normally.

2) **“Thermal” (Red):** lights to indicate that the amplifier has exceeded its safe operating temperature, putting the amplifier into a self-protection mode, which reduces the power output of the amplifier. The red light will shut off and the amplifier will return to normal, full-power operating mode if the heat sink temperature drops back to a safe level.

3) **“Low  $\Omega$ ” (Amber):** lights to indicate that the impedance of the speaker load connected to the amplifier is lower than the optimum load impedance range for the amplifier. When this light is on, a protection circuit engages and reduces the power output of the front or subwoofer channel, depending on which channel is experiencing the problem. The amber indicator will also light when a short-circuit is detected in the speaker wiring (this can be a short between the positive and negative speaker wires or between either speaker wire and the vehicle chassis). This can be used to diagnose a short-circuit by only connecting one of the amplifier sections at a time (front, rear and subwoofer). The amber LED will light when you connect the section that is experiencing the problem and turn the volume up.

### **There is only one condition that will shut down an undamaged 500/5 completely...**

If battery voltage drops below 10 volts, the entire amplifier will shut itself off. The green “Power” indicator on the top of the amplifier will turn off when this occurs. The amplifier will turn back on when voltage climbs back above 10 volts. This may happen in a rapid cycle when bass-heavy program material causes a weak charging system to dip below 10 volts momentarily. If this is happening in your system, have your charging system inspected to make sure it is working properly. A 0.5 or 1.0 Farad rapid-discharge capacitor connected in parallel to the amplifier power connections will minimize these short duration voltage dips in most systems that are having this problem.

**For information on troubleshooting this amplifier, refer to Appendix D (page 26).**

## **SERVICING YOUR JL AUDIO AMPLIFIER**

If your amplifier fails or malfunctions, please return it to your authorized JL Audio dealer so that it may be sent in to JL Audio for service. There are no user serviceable parts or fuses inside the amplifier. The unique nature of the circuitry in the JL Audio amplifiers requires specifically trained service personnel. Do not attempt to service the amplifier yourself or through unauthorized repair facilities. This will not only void the warranty, but may result in the creation of more problems within the amplifier.

If you have any questions about the installation or setup of the amplifier not covered in this manual, please contact your dealer or the **JL AUDIO Technical Department** for assistance:

**(954) 443-1100**  
**9:00 AM – 5:30 PM Eastern Time,**  
**Monday – Friday**

## SYSTEM CONFIGURATIONS

### STEREO BI-AMP MODE:

This is the most common application for a 5-channel amplifier: In this mode, the front satellite speakers, rear satellite speakers and subwoofer(s) are independently powered and filtered. Front and rear channels each have independent high-pass filters and the subwoofer channel has an independent low-pass filter. Left and right front satellite channels deliver 100W x 2 @ 1.5 - 4Ω per channel. Left and right rear satellite channels deliver 25W x 2 @ 3 - 4Ω per channel. One mono subwoofer channel delivers 250W x 1 @ 1.5 - 4Ω.

**Input Connection Options for the Stereo Bi-Amp mode are as follows:**

**A)** Single pair of inputs connected to the rear inputs of the 500/5. In this mode, the user has no fading capability between the front and rear channels and no separate adjustability of subwoofer level from the front of the vehicle. See diagram A below.

**B)** Two pairs of inputs connected to the front and rear inputs of the 500/5 (a source unit or processor with front and rear pairs of outputs is required). In this mode, the user has front-to-rear fading capability with non-fading sub-bass level. This means that the relative level of the front and rear satellites

can be controlled with the source unit fader, without affecting the level of the subwoofer channel. See diagram B below.

**Note:** This configuration can also be set up so that the subwoofer level tracks with the front channel level. To configure the system in this manner, go to the **"Subwoofer Channel Control Section"** / **"Input From"** selector switch and select **"Front"** instead of **"F+R"**.

**C)** Two pairs of inputs connected to the rear and subwoofer inputs of the 500/5 (a source unit or processor with front and rear outputs is required). In this mode, the source unit or

processor fader adjusts the relative level of the subwoofer channel vs. all four satellite channels as a whole. The relative level of the front and rear channels is pre-set with the amplifier input sensitivity controls and cannot be adjusted from the source unit. See diagram C on page 16.

**D)** Three pairs of inputs connected to the rear, front and subwoofer inputs of the 500/5. This mode is applicable for use in systems with a source unit or processor that provides discrete front, rear and subwoofer outputs. In this mode, the subwoofer level and front to rear fading can be controlled from the front of the vehicle. See diagram D on page 16.

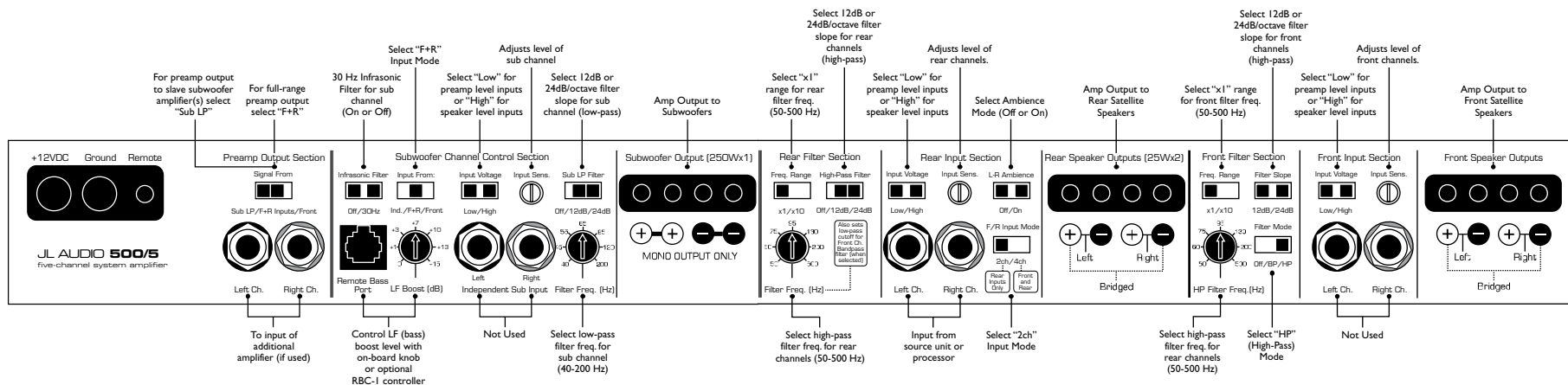

**A) Single pair of inputs connected to the rear inputs of the 500/5. In this mode, the user has no fading capability between the front and rear channels and no adjustability of subwoofer level from the front of the vehicle.**

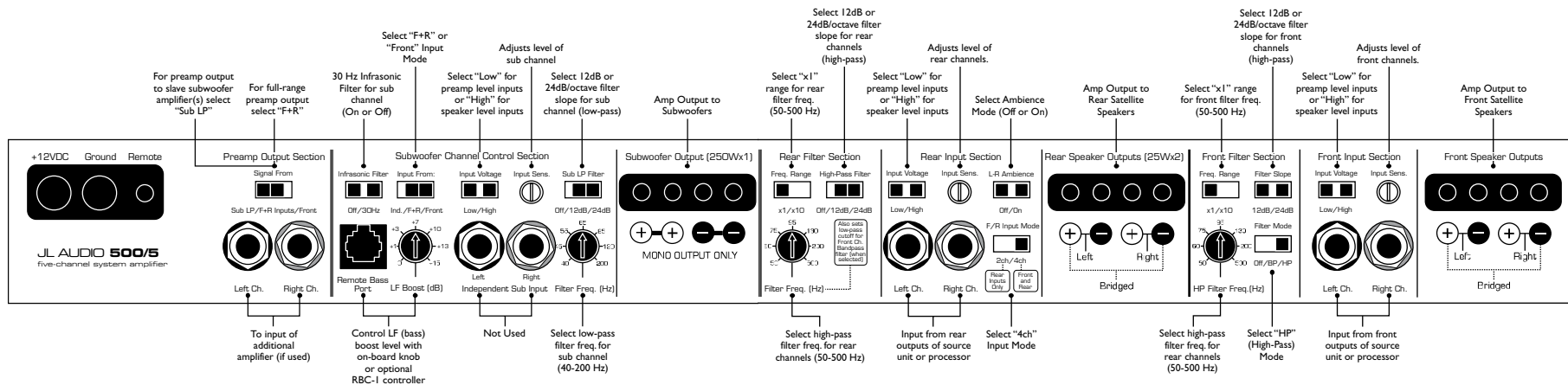

**B) Two pairs of inputs connected to the front and rear inputs of the 500/5 (a source unit or processor with front and rear pairs of outputs is required). In this mode, the user has front-to-rear fading capability with non-fading sub-bass level. This means that the relative level of the front and rear satellites can be controlled with the source unit fader, without affecting the level of the subwoofer channel.**

Note: This configuration can also be set up so that the subwoofer level tracks with the front channel level and only the rear channels are faded. To configure the system in this manner, go to the Subwoofer Channel Control Section "Input From" selector switch and select "Front" instead of "F+R".



**! IMPORTANT**

Some source units and processors with subwoofer preamp outputs provide low-pass filtering on these outputs, while others have a full-range output. Consult your source unit or processor owner's manual to determine the properties of the subwoofer preamp output.

- If your sub preamp output is full-range, engage the 500/5's sub low-pass filter by selecting the "12dB" or "24dB" position on the "Sub LP Filter" switch. This configuration is illustrated in the setup diagram.

- If your sub preamp output has a choice between full-range and low-pass modes, select the full-range mode and use the 500/5's (likely more sophisticated) sub low-pass filter by selecting the "12dB" or "24dB" position on the "Sub LP Filter" switch. This configuration is illustrated in the setup diagram.
- If the source unit/processor sub preamp output has a low-pass filter which is not defeatable, you can turn the 500/5's low-pass filter off by going to the "Subwoofer Channel Control Section" / "Sub LP Filter" switch and selecting the "Off"

position. Depending on the crossover point and slope of the source unit/processor's filter, you may wish to engage the 500/5's sub low-pass filter to fine-tune the sub-bass response.

- If you are using a high-quality outboard active crossover, you can defeat all of the 500/5's filters by selecting the "Off" position on the "Sub LP Filter" switch in the "Subwoofer Channel Control Section", the "High-Pass Filter" switch in the Rear Filter Section and the "Filter Mode" switch in the Front Filter Section.

**L-R Ambience Control:**

This switch, located in the "Rear Filter Section", performs a very useful function when operating the amplifier in bi-amp mode. By switching this circuit to the "On" position, all signal common to both left and right channels is removed from the signal feeding the rear channels of the 500/5. When the circuit is "On", the rear channels will only reproduce the extreme left and right information in the recording, creating a realistic ambient effect from the rear channels without detracting from the imaging of the front speaker system. Experiment with this switch to determine if this feature enhances the sound of your system.

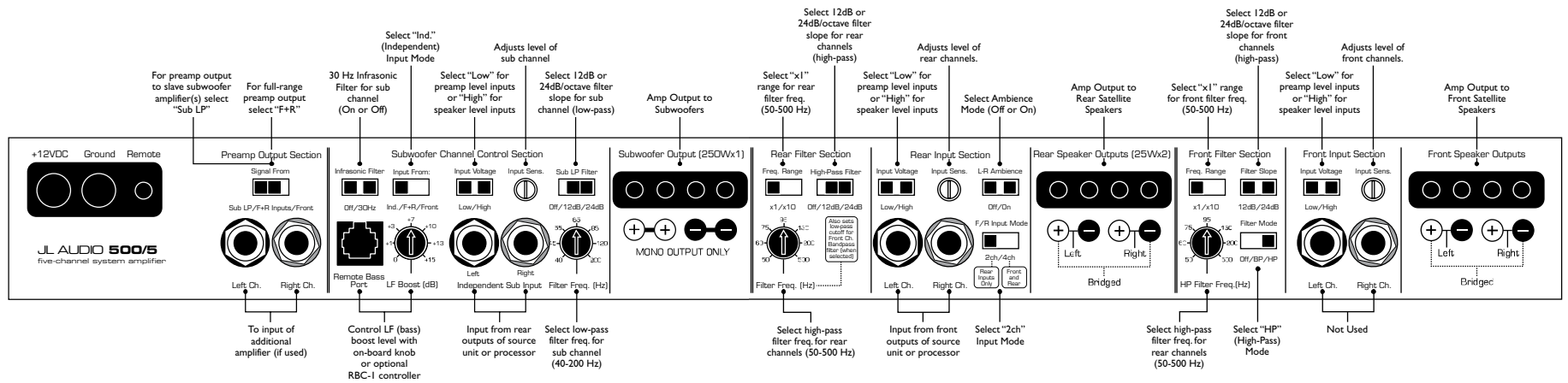

**C) Two pairs of inputs connected to the rear and subwoofer inputs of the 500/5 (a source unit or processor with front and rear outputs is required). In this mode, the source unit or processor fader adjusts the relative level of the subwoofer channel vs. all four satellite channels as a whole. The relative level of the front and rear channels is pre-set with the amplifier input sensitivity controls and cannot be adjusted from the source unit.**

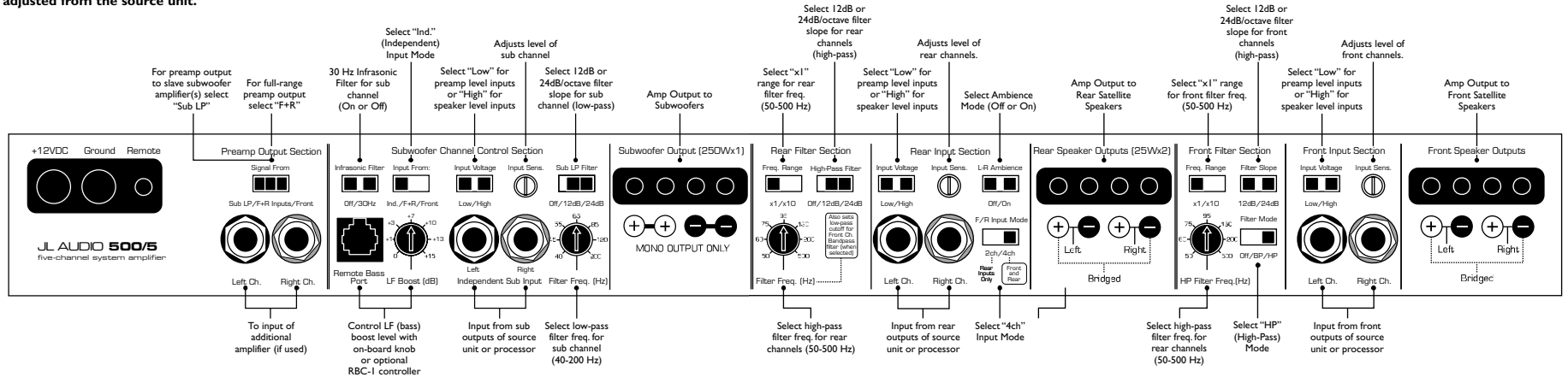

**D) Three pairs of inputs connected to the rear, front and subwoofer inputs of the 500/5. This mode is applicable for use in systems with a source unit or processor that provides discrete front, rear and subwoofer outputs. In this mode, the subwoofer level and front to rear fading can be controlled from the front of the vehicle.**

## STEREO TRI-AMP MODE:

In this mode, the bandpass feature on the front channels is activated, configuring the 500/5's crossover sections to true three-way operation. This allows the independent powering of tweeters, midwoofers and subwoofer(s) in the system and gives extensive control over level matching and crossover parameters. Left and right tweeter channels (25W x 2 @ 3 - 4Ω per channel), high-pass filtered. Left and right midwoofer channels (100W x 2 @ 1.5 - 4Ω per channel), bandpass filtered. One mono subwoofer channel (250W x 1 @ 1.5 - 4Ω), low-pass filtered.

Input connection options for the Tri-amp Stereo mode are as follows:

- A) Single pair of inputs connected to the rear inputs of the 500/5. In this mode, the user has no adjustability of subwoofer level from the front of the vehicle. See diagram A below.
- B) Two pairs of inputs connected to the rear and subwoofer inputs of the 500/5 (a source unit or processor with front and rear pairs of outputs is required). In this mode, the user has the ability to fade or control the level of the subwoofer channel relative to the mid and high-frequency channels. See diagram B below.

## L-R Ambience Control:

This switch, located in the "Rear Filter Section", should be set to the "Off" position when operating the amplifier in Tri-Amp Mode.

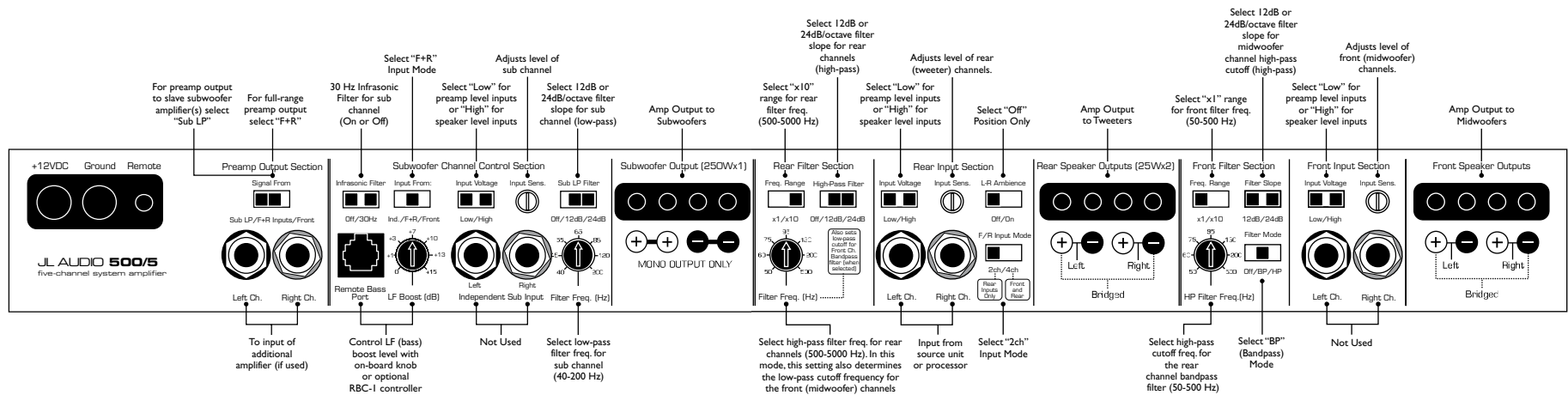

A) Single pair of inputs connected to the rear inputs of the 500/5. In this mode, the user has no adjustability of subwoofer level from the front of the vehicle.

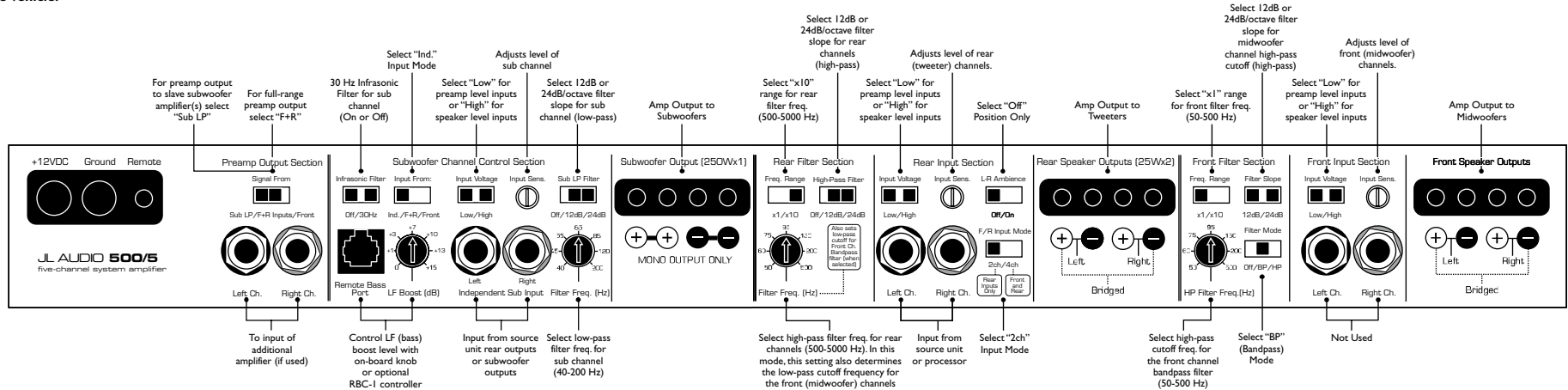

B) Two pairs of inputs connected to the rear and subwoofer inputs of the 500/5 (a source unit or processor with front and rear pairs of outputs is required). In this mode, the user has the ability to fade or control the level of the subwoofer channel relative to the mid and high-frequency channels.

**APPENDIX A:**

Precise Frequency Selection Chart

**CHART A-1**

**“FILTER FREQ” FRONT & REAR CH. FILTERS**

Detent Number	Panel Marking	Actual Freq.
<b>Full counter-clockwise: 58</b>		
01		.58
02	“50”	.58
03		.58
04		.58
05		.59
06		.60
07		.61
08	“60”	.63
09		.65
10		.67
11		.69
12		.71
13		.74
14	“75”	.77
15		.80
16		.82
17		.85
18		.90
19		.93
20	“95”	.97
21		.102
22		.107
23		.113
24		.120
25		.127
26	“130”	.135
27		.143
28		.153
29		.171
30		.182
31		.201
32	“200”	.223
33		.253
34		.289
35		.337
36		.404
37		.474
38	“500”	.514
39		.525
<b>Full-clockwise: 542</b>		

**CHART A-2**

**“FILTER FREQ” SUBWOOFER CH. FILTER**

Detent Number	Panel Marking	Actual Freq.
<b>Full counter-clockwise: 42</b>		
01		.42
02		.42
03		.42
04	“40”	.42
05		.43
06		.44
07		.46
08	“45”	.47
09		.49
10		.50
11		.52
12		.53
13		.55
14	“55”	.57
15		.58
16		.60
17		.63
18		.65
19	“65”	.67
20		.70
21		.73
22		.76
23		.79
24	“80”	.83
25		.87
26		.92
27		.96
28		.102
29	“100”	.108
30		.114
31		.122
32		.131
33		.143
34		.157
35		.184
36	“200”	.193
37		.198
38		.198
39		.198
<b>Full-clockwise : 198</b>		

## APPENDIX B:

### Input Sensitivity Level Setting

JL Audio amplifiers utilizing the Regulated Intelligent Power Supply (R.I.P.S.) allow delivery of their rated power when connected to any load impedance from 1.5 - 4Ω per channel (3 - 8Ω bridged) and when connected to a charging system with any voltage from 11 - 14.5V. This design is beneficial for many reasons. One of these reasons is ease of setup. Because each JL Audio amplifier will always deliver the same amount of power within its operational range of impedances and supply voltages, the maximum, unclipped output is very predictable. This makes setting the gain structure via the input sensitivity controls very simple. Following the directions below will allow the user to adjust the input sensitivity of the amplifier(s) simply and easily in just a few minutes using equipment which is commonly available in installation bays.

#### Necessary Equipment

- Digital AC Voltmeter
- CD with a sine-wave test tone recorded at 0 dB reference level in the frequency range to be amplified for that set of channels (50 Hz for subwoofer channels, 1 kHz for a midrange application). Do not use attenuated test tones (-10 dB, -20 dB, etc.).

#### The Nine-Step Procedure

(follow this procedure for each set of channels)

- 1) Disconnect the speaker(s) from the amplifier's "Front", "Rear" and "Subwoofer Output" connectors.
- 2) Turn "Off" all processing on the source unit and amplifier (bass/treble, loudness, EQ, etc.).
- 3) In all three input sections, switch the "Input Voltage" to "Low" and turn the "Input Sens." control all the way down (counterclockwise).
- 4) Set the source unit volume to 3/4 of full volume. If either set of channels is being driven by a source unit's dedicated subwoofer output, also adjust the source unit's subwoofer level control to 3/4 of maximum output. This will allow for reasonable gain overlap with moderate clipping at full volume.
- 5) Using the chart below, determine the target voltage for input sensitivity adjustment according to the nominal impedance of the speaker system connected to each set of outputs.
- 6) Verify that you have disconnected the speakers before proceeding. Play a track with an appropriate sine wave (within the frequency range to be amplified by the set of channels being adjusted) at 3/4 source unit volume.

7) Connect the AC voltmeter to the "Speaker Outputs" or "Subwoofer Output" connectors of the channel set that you are adjusting. For the stereo channels, it is only necessary to measure one channel. If bridged, make sure you test the voltage at the correct connectors (L+ and R-).

8) Increase the "Input Sens." control until the target voltage is delivered for that set of channels. If excessive voltage is read on either set of channels with the control at minimum (full counterclockwise), switch the appropriate "Input Voltage" switch to "High" and re-adjust.

9) Once you have adjusted each set of channels to its maximum unclipped output level, reconnect the speaker(s). The "Input Sens." controls can now be adjusted **downward** if any channels require attenuation to achieve the desired system balance.

#### ! IMPORTANT

Do not increase any "Input Sens." setting in the system beyond the maximum level established during this procedure. Doing so will result in audible distortion and possible speaker damage.

It will be necessary to re-adjust the "Input Sens." for the affected channels if any equalizer boost is activated after setting the "Input Sens." with this procedure. This applies to any EQ boost circuit, including the amplifier's "Bass EQ" and source unit tone controls or EQ circuits. EQ cuts will not require re-adjustment.

Nom. Imp.	FRONT CH.		REAR CH.		SUB CH.
	Stereo	Bridged	Stereo	Bridged	Mono
8Ω	20.0 V	40.0 V	10.0 V	20.0 V	31.6 V
6Ω	20.0 V	34.6 V	10.0 V	17.4 V	31.6 V
4Ω	20.0 V	28.4 V	10.0 V	not recommended	31.6 V
3Ω	17.3 V	24.6 V	8.7 V	not recommended	27.4 V
2Ω	14.2 V	not recommended	not recommended	not recommended	22.4 V
1.5Ω	12.3 V	not recommended	not recommended	not recommended	19.4 V

## APPENDIX C:

### Master/Slave Configurations

With the flexible on-board crossovers and processing incorporated into the 500/5, it is possible to connect additional JL Audio 250/1 amplifiers in a "Master/Slave" configuration, with each amplifier driving its own speaker system but controlled by the processing and filtering of the 500/5's subwoofer section. This is very useful if additional subwoofer power is desired in a system.

To create a Master/Slave configuration, configure the 500/5's subwoofer section as you would normally do to drive one subwoofer system, then do the following to connect additional slave amplifiers:

1) In the Preamp Output Section of the 500/5 select the "Sub LP" position on the "Signal From" switch. This will send a parallel, mono-summed signal from the 500/5's "Sub LP Filter" section to its preamp outputs.

2) Connect an RCA cable from the 500/5's preamp outputs to the main input of the first "Slave" 250/1 amplifier. Set the "Slave" amplifier's "Amp LP Filter" to the "Off" position. This will defeat the LP filter and the bass processing of this "Slave Amplifier".

3) The input sensitivity of the two amplifiers needs to be adjusted independently. Set the subwoofer channel of the 500/5 and the slave 250/1 amplifier to the same target voltage using the procedure outlined in Appendix B (page 22).

**Do not increase the "Input Sens." setting for any amplifier channel in the system beyond the maximum level established during the procedure outlined in Appendix B (page 22). Doing so will result in audible distortion and possible speaker damage.**

4) If you would like to run a third amplifier in "Slave" configuration, select the "Full-Range" position on the "Output Mode" switch of the first "Slave" amp. Then, connect an RCA cable from the first "Slave" amplifier's preamp outputs to the second "Slave" amplifier. As you did with the first "Slave" amp, set the second "Slave" amplifier's "Amp LP Filter" to the "Off" position. Then, calibrate the third amplifier's "Input Range" and "Input Sens." controls in the same manner as you did for the second amplifier.

Additional amplifiers may be added to this "Master/Slave" configuration following the same procedure as in step 4.

Once you match the input sensitivities of all the amplifiers, you can use the "Master" amplifier's "Sub LP Filter", "Infrasonic Filter" and "LF Boost"

features to control the "Slave" amplifier(s).

The diagram below shows a Master/Slave configuration with one "Master" 500/5 (top amplifier) and two "Slave" 250/1 amplifiers. Switches and controls that are defeated in the "Slave" amplifiers are printed in gray.

**NOTE:** These settings are intended as a "baseline" for tuning this system. Depending on the vehicle, personal taste and the audio components specific to your system, some variation in the Subwoofer Channel Control Section, Filter Sections and Input Sections may be necessary for optimum performance.

**MASTER:** The Master amplifier's bass processing features are active and affect all three amplifiers equally.

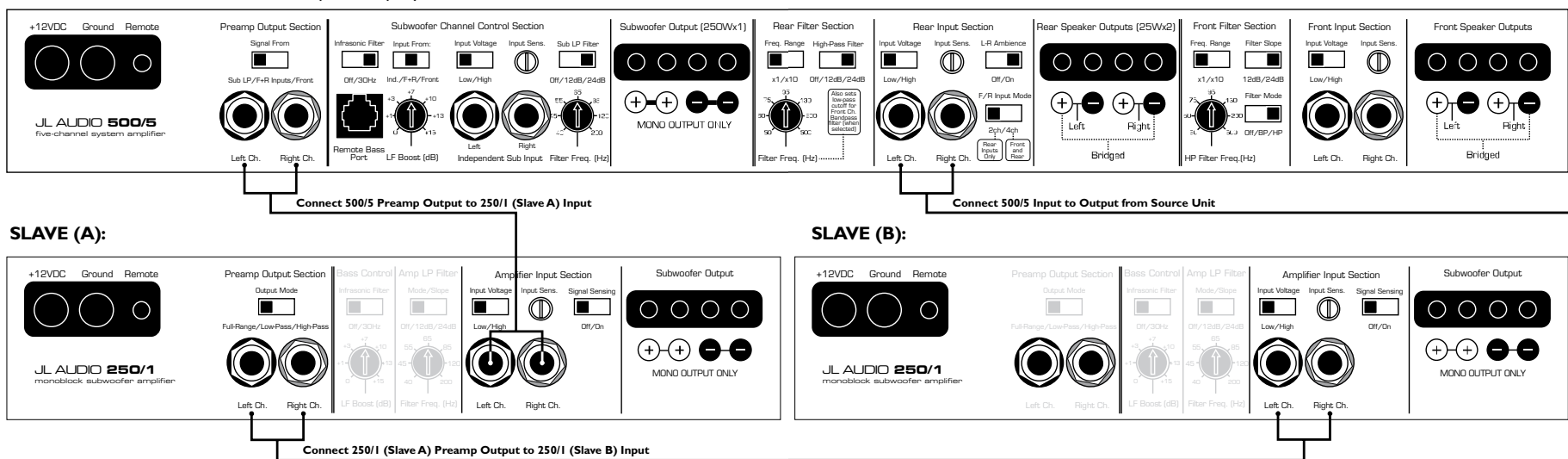

This Slave amplifier's bass processing features are inactive, but the Full-Range (pass-through) feature of its "Preamp Output" feeds the input of the next Slave amplifier.

The last Slave amplifier's bass processing features are inactive. The "Amp LP Filter" and "Preamp Output" are also inactive.

### **“MY AMPLIFIER DOESN'T TURN ON”**

---

**Check** to make sure there is +12V at the “Remote” connection of the amplifier. In some cases, the turn-on lead from the source unit is insufficient to turn on multiple devices and the use of a relay is required. To test for this problem, jump the “+12V” wire to the “Remote” terminal to see if the amplifier turns on. If this does not work, proceed to the next step.

**Check** the fuse, not just visually, but with a continuity meter. It is possible for a fuse to have poor internal connections that cannot be found by visual inspection. It is best to take the fuse out of the holder for testing. If no problem is found with the fuse, inspect the fuse-holder.

### **“I GET A DISTORTED / ATTENUATED SOUND COMING OUT OF THE SPEAKER(S)”**

---

**Check** the speaker wires for a possible short, either between the positive and negative or between a speaker lead and the vehicle's chassis ground. If a short is present you will experience distorted and/or attenuated output. The “Low  $\Omega$ ” light may also illuminate in this situation. It may be helpful to disconnect the speaker wires from the amplifier and use a different set of wires connected to a test speaker.

**Check** the nominal load impedance to verify that the front and subwoofer channels of the amplifier are driving loads between 1.5 - 4 $\Omega$  per channel and that the rear channels are driving loads between 3 - 4 $\Omega$  per channel.

**Check** the input signal and input signal cables to make sure signal is present at all active inputs and the cables are not pinched or loose. It may be helpful to try a different set of cables and/or a different signal source to be sure.

### **“MY AMPLIFIER SHUTS OFF ONCE IN A WHILE, USUALLY AT HIGHER VOLUMES”**

---

**Check** your voltage source and grounding point. The R.I.P.S. power supply is rated to operate with source voltages between 11 - 14.5V. Shutdown problems at higher levels can occur when the charging system voltage drops below 10 volts. These dips can be of very short duration making them extremely difficult to detect with a common DC voltmeter. To ensure proper voltage, inspect all wiring and termination points. It is also a good idea to improve the vehicle's factory ground wire and termination point. Grounding problems are the leading cause of mis-diagnosed amplifier failures.

### **“MY AMPLIFIER TURNS ON, BUT THERE IS NO OUTPUT”**

---

**Check** the input signal using an AC voltmeter to measure the voltage from the source unit while an appropriate test tone is played through the source unit (disconnect the RCA cables from the amplifier prior to this test). The frequency used should be in the range that is to be amplified by the channels being tested (example: 50 Hz for a sub bass amplifier channel and 1 kHz for a full range amplifier channel). A steady voltage should be present at the output of the RCA cables. If you are receiving a sufficient voltage (between 0.2 and 8.0-volts), check to ensure that the speaker wires are making a good connection with the metal inside the amplifier. The connectors are designed to accept up to an 8 AWG wire. If you are using significantly smaller wire (14 AWG or smaller), you may have difficulty making an adequate connection. In this case, you may find it necessary to “fold” the wire over once (or twice!) so as to make a solid connection. Make sure to strip the wire to allow for a sufficient connection with the input or output of the amplifier.

**Check** the output of the amplifier. Using the procedure explained in the previous check item (after plugging the RCA cables back into the amplifier) test for output at the speaker outputs of the amplifier. Unless you enjoy test tones at high levels, it is a good idea to remove the speaker wires from the amplifier while doing this. Turn the volume up approximately half way. 5 volts or more should be measured at the speaker outputs. This output level can vary greatly between amplifiers but it should not be in the millivolt range with the source unit at half volume. If you are reading sufficient voltage, check your speaker connections as explained above.

### **“MY AMPLIFIER'S OUTPUT FLUCTUATES WHEN I TAP ON IT OR HIT A BUMP”**

---

**Check** the connections to the amplifier. Make sure that the insulation for all wires has been stripped back far enough to allow a good contact area inside the amplifier terminal.

**Check** the RCA connectors to ensure that both the center pin and the outer shield are making good contact with the input jacks on the amplifier.

### **“HOW DO I PROPERLY SET THE INPUT SENSITIVITY ON MY AMPLIFIER”**

---

**Please** refer to Appendix B (page 22) to set the input sensitivity for maximum, low-distortion output.

## APPENDIX E: 500/5 Specifications

### GENERAL SPECIFICATIONS:

**Recommended Fuse Value:** 50A

**Recommended Fuse Type:** AGU or MaxiFuse™

### INPUT SECTIONS:

**No. of Inputs:** Three Stereo Pairs (Front, Rear, Subwoofer)

**Input Type:** Differential-balanced with RCA jack inputs

**Input Range:** Switchable from 200mV - 2V RMS to 800mV - 8V RMS

### FRONT CHANNELS:

**Amplifier Topology:** Class AB with patented Absolute Symmetry™ dual N-Channel MOSFET output design

**Power Supply:** Independent, pulse width modulation-regulated switching power supply with multistage impedance optimizing circuitry.

**Rated Power (Stereo):**

100W RMS x 2 @ 1.5 - 4Ω (11V - 14.5V)

**Rated Power (Bridged):**

200W RMS x 1 @ 3 - 8Ω (11V - 14.5V)

**THD at Rated Power:** <0.03% @ 4Ω per channel (20 Hz-20 kHz)

**Signal to Noise Ratio:** >108.5 dB referred to rated power (A-weighted, 20 Hz-20 kHz noise bandwidth)

**Frequency Response:** 5 Hz - 30 kHz (+0, -1 dB)

**Damping Factor:** >200 @ 4Ω per ch. / 50 Hz, >100 @ 2Ω per ch. / 50 Hz

**Slew Rate:** ± 25V/μs

**Front Filter:** State-variable, 12 dB/octave Butterworth or 24 dB/octave Linkwitz-Riley High-Pass with continuously variable cutoff frequency from 50 - 500 Hz, switchable to a range of 500 - 5000 Hz, via x10 switch.

Can also be cascaded from rear filter's cutoff frequency to operate as a bandpass filter for tri-amp configurations. Defeatable.

### REAR CHANNELS:

**Amplifier Topology:** Class AB with patented Absolute Symmetry™ dual N-Channel MOSFET output design

**Power Supply:** Independent, pulse width modulation-regulated switching power supply.

**Rated Power (Stereo):**

25W RMS x 2 @ 3 - 4Ω (11V - 14.5V)

**Rated Power (Bridged):**

50W RMS x 1 @ 6 - 8Ω (11V - 14.5V)

**THD at Rated Power:** <0.03% @ 4Ω per channel (20 Hz - 20 kHz)

**Signal to Noise Ratio:** >108.5 dB referred to rated power (A-weighted, 20 Hz - 20 kHz noise bandwidth)

**Frequency Response:** 5 Hz - 30 kHz (+0, -1 dB)

**Damping Factor:** >200 @ 4Ω per ch. / 50 Hz, >100 @ 2Ω per ch. / 50 Hz

**Slew Rate:** ± 25V/μs

**Rear Filter:** State-variable, 12 dB/octave Butterworth or 24 dB / octave Linkwitz-Riley high-pass with continuously variable cutoff frequency from 50 - 500 Hz, switchable to a range of 500 - 5000 Hz, via x10 switch. Also provides low-pass cutoff for front filter when bandpass mode is used.

### SUBWOOFER CHANNEL:

**Amplifier Topology:** H-Bridge, Class D Mono with impedance optimization and patented discrete drive circuitry

**Power Supply:** Independent, pulse width modulation-regulated switching power supply

**Rated Power:** 250W RMS x 1 @ 1.5 - 4Ω (11V - 14.5V)

**THD at Rated Power:** <0.05% @ 4Ω (50 Hz)

**Signal to Noise Ratio:** >95 dB referred to rated power (A-weighted, 20 Hz - 20 kHz noise bandwidth)

**Frequency Response:** 5 Hz - 300 Hz (+0, -1 dB), 5 Hz - 500 Hz (+0, -3 dB)

**Damping Factor:** >500 @ 4Ω / 50 Hz, >250 @ 2Ω / 50 Hz

**Subwoofer Channel Filter:** State-variable, 12 dB/octave Butterworth or 24 dB / octave Linkwitz-Riley low-pass with continuously variable cutoff frequency from 40 - 200 Hz. Defeatable.

**LF Boost:** Single-band, fixed-frequency (48 Hz), fixed "Q" boost, variable from 0 to +15 dB. Defeatable. Port for optional remote bass control to control variable boost from front of vehicle.

**Infrasonic Filter:** 24 dB/octave @ 30 Hz. Defeatable.

### PREAMP OUTPUT:

Tracking type low-pass linked to subwoofer channel filter.

Filtering is defeatable to pass a full-range signal from the front channel inputs or a summed signal from the front and rear channel inputs.

### DIMENSIONS (LxWxH):

19.7" x 9.25" x 2.36" (500mm x 235mm x 60mm)

Due to ongoing product development, all specifications are subject to change without notice.

**INSTALLATION NOTES:**

Use this diagram to document your amplifier's switch and control positions.

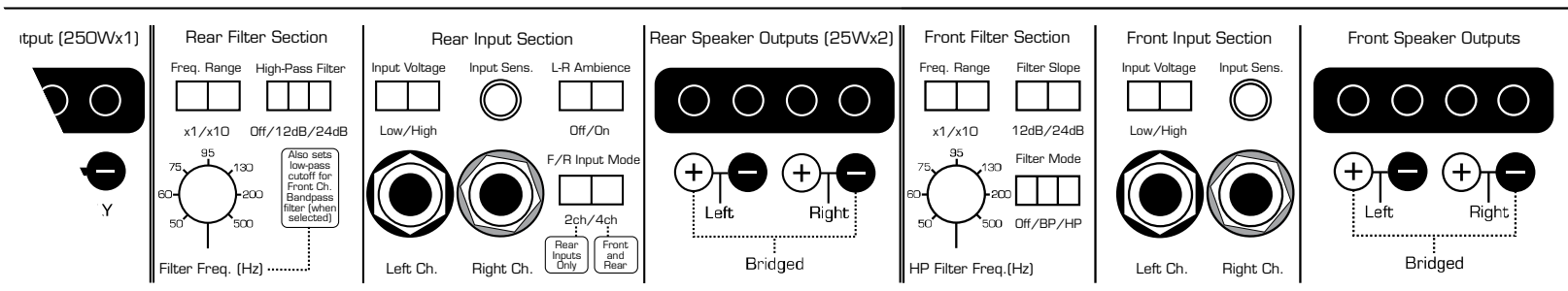
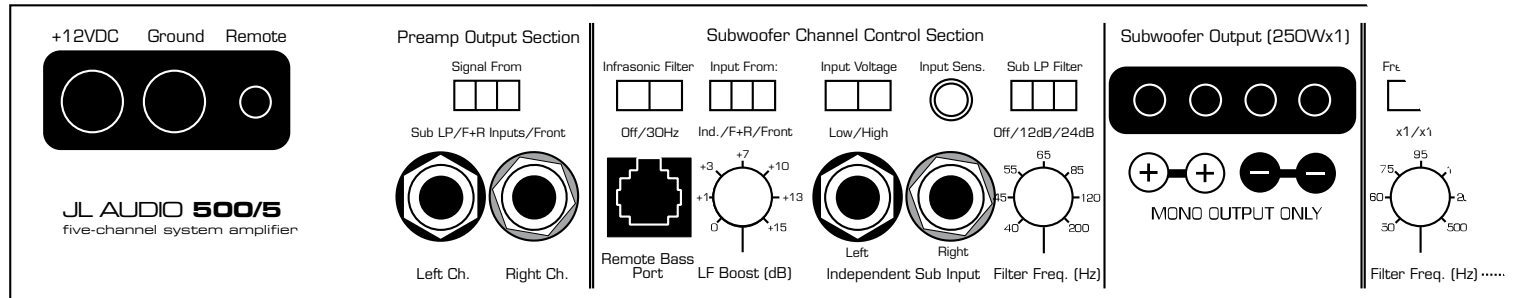



## LIMITED WARRANTY - AMPLIFIERS (USA)

JL AUDIO warrants this product to be free of defects in materials and workmanship for a period of ninety (90) days from the original date of purchase. The warranty term is extended to two (2) years if installation is performed or approved by an authorized JL AUDIO dealer (proof of installation or approval required on purchase receipt).

This warranty is not transferrable and applies only to the original purchaser from an authorized JL AUDIO dealer. Should service be necessary under this warranty for any reason due to manufacturing defect or malfunction, JL AUDIO will (at its discretion), repair or replace the defective product with new or remanufactured product at no charge. Damage caused by the following is not covered under warranty: accident, misuse, abuse, product modification or neglect, failure to follow installation instructions, unauthorized repair attempts, misrepresentations by the seller. This warranty does not cover incidental or consequential damages and does not cover the cost of removing or reinstalling the unit(s). Cosmetic damage due to accident or normal wear and tear is not covered under warranty.

### Warranty is void if the product's serial number has been removed or defaced.

Any applicable implied warranties are limited in duration to the period of the express warranty as provided herein beginning with the date of the original purchase at retail, and no warranties, whether express or implied, shall apply to this product thereafter. Some states do not allow limitations on implied warranties, therefore these exclusions may not apply to you. This warranty gives you specific legal rights, and you may also have other rights which vary from state to state.

### If you need service on your JL AUDIO product:

All warranty returns should be sent to JL AUDIO 's Amplifier Service Facility freight-prepaid through an authorized JL AUDIO dealer and must be accompanied by proof of purchase (a copy of the original sales receipt). Direct returns from consumers or non-authorized dealers will be refused unless specifically authorized by JL AUDIO with a valid return authorization number.

Warranty expiration on products returned without proof of purchase will be determined from the manufacturing date code. Coverage may be invalidated as this date is previous to purchase date. Non-defective items received will be returned freight-collect. Customer is responsible for shipping charges and insurance in sending the product to JL AUDIO. Freight damage on returns is not covered under warranty.

### For Service Information in the U.S.A. please call:

JL Audio customer service: (954) 443-1100  
during normal business hours (9:00 AM – 5:30 PM Eastern Time)

#### JL Audio, Inc

10369 North Commerce Pkwy,  
Miramar, FL 33025

(do not send product for repair to this address)

### International Warranties:

Products purchased outside the United States of America are covered only  
by that country's distributor and not by JL Audio, Inc.

**Absolute Symmetry™ Class AB Amplifier Circuit is covered by U.S. Patent #6,294,959 and is pending in the countries listed below.** Austria, Belgium, Brazil, Canada, China, France, Germany, Indonesia, Italy, Japan, Republic of Korea, Mexico, Netherlands, Norway, Russian Federation, Singapore, Sweden, Switzerland, United Kingdom, and all other PCT countries.

## Free Manuals Download Website

<http://myh66.com>

<http://usermanuals.us>

<http://www.somanuals.com>

<http://www.4manuals.cc>

<http://www.manual-lib.com>

<http://www.404manual.com>

<http://www.luxmanual.com>

<http://aubethermostatmanual.com>

Golf course search by state

<http://golfingnear.com>

Email search by domain

<http://emailbydomain.com>

Auto manuals search

<http://auto.somanuals.com>

TV manuals search

<http://tv.somanuals.com>