

# **JET**

**EQUIPMENT & TOOLS**

## **OPERATOR'S MANUAL** **HBS-916W & 1018W Bandsaws**

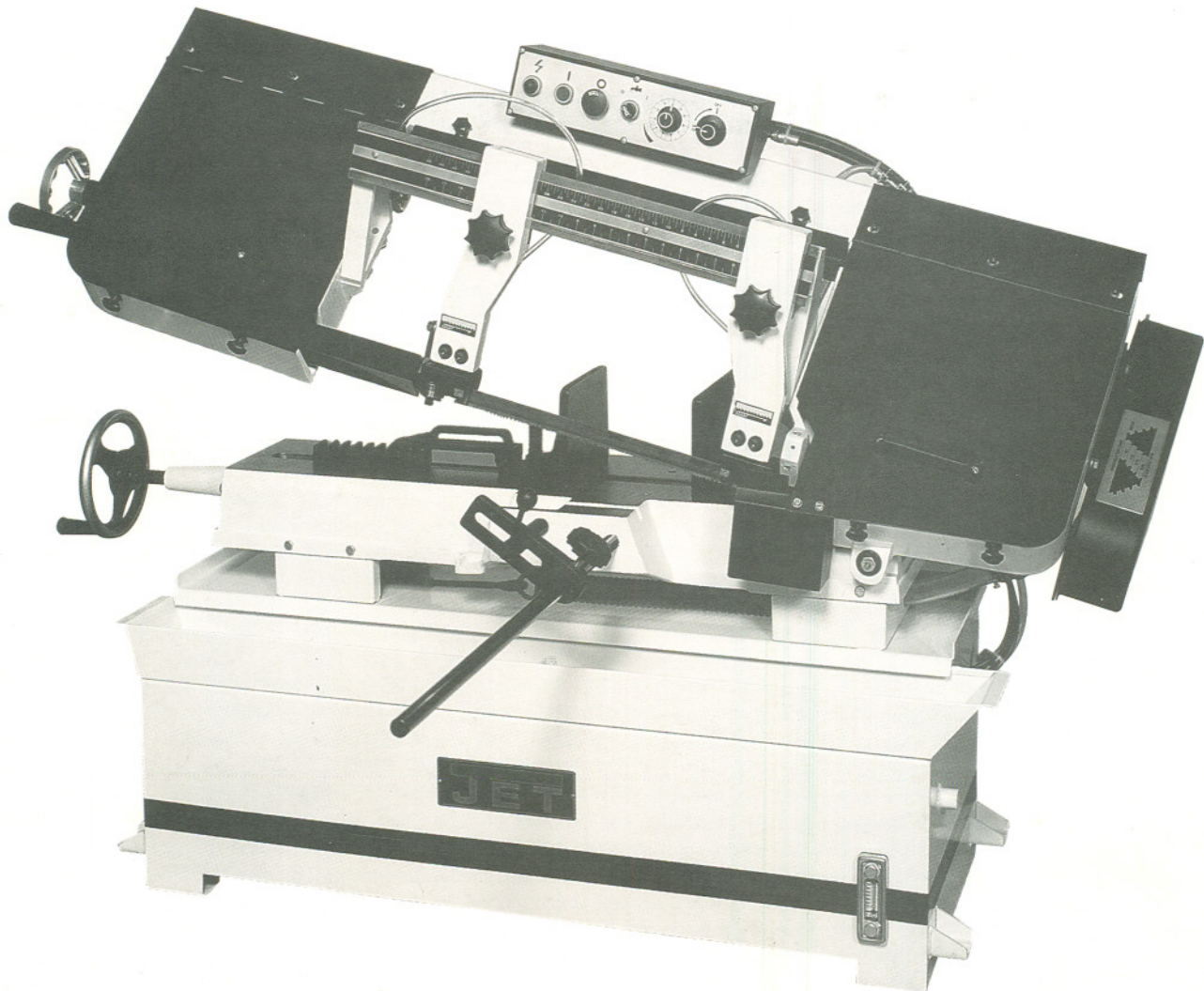

**JET EQUIPMENT & TOOLS, INC.**  
A WMH Company  
[www.jettools.com](http://www.jettools.com)

P.O. BOX 1349  
Auburn, WA 98071-1349  
e-mail [jet@jettools.com](mailto:jet@jettools.com)

253-351-6000  
Fax 253-939-8001  
**M-414468 2/99**

# Important Information

**1-YEAR  
LIMITED WARRANTY**

**JET offers a one-year limited  
warranty on this product**

## REPLACEMENT PARTS

Replacement parts for this tool are available directly from JET Equipment & Tools.

To place an order, call 1-800-274-6848. Please have the following information ready:

1. Visa, MasterCard, or Discover Card number
2. Expiration date
3. Part number listed within this manual
4. Shipping address other than a Post Office box.

## REPLACEMENT PART WARRANTY

JET Equipment & Tools makes every effort to assure that parts meet high quality and durability standards and warrants to the original retail consumer/purchaser of our parts that each such part(s) to be free from defects in materials and workmanship for a period of thirty (30) days from the date of purchase.

## PROOF OF PURCHASE

Please retain your dated sales receipt as proof of purchase to validate the warranty period.

## LIMITED TOOL AND EQUIPMENT WARRANTY

JET makes every effort to assure that its products meet high quality and durability standards and warrants to the original retail consumer/purchaser of our products that each product be free from defects in materials and workmanship as follows: 1 YEAR LIMITED WARRANTY ON THIS JET PRODUCT. Warranty does not apply to defects due directly or indirectly to misuse, abuse, negligence or accidents, repairs or alterations outside our facilities or to a lack of maintenance. JET LIMITS ALL IMPLIED WARRANTIES TO THE PERIOD SPECIFIED ABOVE FROM THE DATE THE PRODUCT WAS PURCHASED AT RETAIL. EXCEPT AS STATED HEREIN, ANY IMPLIED WARRANTIES OR MERCHANTABILITY AND FITNESS ARE EXCLUDED. SOME STATES DO NOT ALLOW LIMITATIONS ON HOW LONG THE IMPLIED WARRANTY LASTS, SO THE ABOVE LIMITATION MAY NOT APPLY TO YOU. JET SHALL IN NO EVENT BE LIABLE FOR DEATH, INJURIES TO PERSONS OR PROPERTY OR FOR INCIDENTAL, CONTINGENT, SPECIAL OR CONSEQUENTIAL DAMAGES ARISING FROM THE USE OF OUR PRODUCTS. SOME STATES DO NOT ALLOW THE EXCLUSION OR LIMITATION OF INCIDENTAL OR CONSEQUENTIAL DAMAGES, SO THE ABOVE LIMITATION OR EXCLUSION MAY NOT APPLY TO YOU. To take advantage of this warranty, the product or part must be returned for examination, postage prepaid, to an authorized service station designated by our Auburn office. Proof of purchase date and an explanation of the complaint must accompany the merchandise. If our inspection discloses a defect, JET will either repair or replace the product or refund the purchase price, if we cannot readily and quickly provide a repair or replacement, if you are willing to accept such refund. JET will return repaired product or replacement at JET's expense, but if it is determined there is no defect, or that the defect resulted from causes not within the scope of JET's warranty, then the user must bear the cost of storing and returning the product. This warranty gives you specific legal rights, and you have other rights, which vary, from state to state.

**JET Equipment & Tools • P.O. Box 1349, Auburn, WA 98071-1349 • (253) 351-6000**

 **WARNING**

- **Read and understand the entire instruction manual before attempting assembly or operation.**
- **All JET bandsaws are designed and intended for use by properly trained and experienced personnel only. If you are not familiar with the proper and safe operation of a bandsaw, do not use until proper training and knowledge have been obtained.**
- Always wear approved safety glasses/face shields while using this machine.
- Make certain the machine is properly grounded.
- Before operating the machine, remove tie, rings, watches, other jewelry, and roll up sleeves above the elbows. Remove all loose clothing and confine long hair. Do NOT wear gloves.
- Keep the floor around the machine clean and free of scrap material, oil and grease.
- Keep machine guards in place at all times when the machine is in use. If removed for maintenance purposes, use extreme caution and replace the guards immediately.
- Do NOT over reach. Maintain a balanced stance at all times so that you do not fall or lean against blades or other moving parts.
- Make all machine adjustments or maintenance with the machine unplugged from the power source.
- Use the right tool. Don't force a tool or attachment to do a job which it was not designed for.
- Replace warning labels if they become obscured or removed.
- Make certain the motor switch is in the OFF position before connecting the machine to the power supply.
- Give your work undivided attention. Looking around, carrying on a conversation, and "horse-play" are careless acts that can result in serious injury.
- Keep visitors a safe distance from the work area.
- Use recommended accessories; improper accessories may be hazardous.
- Make a habit of checking to see that keys and adjusting wrenches are removed before turning on the machine.
- Always keep hands and fingers away from the blade when the machine is running.
- Never hand hold the material. Always use the vise and clamp it securely.
- Keep belt guard, blade guards, and wheel covers in place and in working order.
- Always provide adequate support for long and heavy material.
- Use a sharp blade and keep machine clean for best and safest performance.
- Failure to comply with all of these warnings may cause serious injury.

**Specifications:****HBS-916W****HBS-1018W**

Stock Number .....	414468 .....	414473
Capacity:		
Round at 90° .....	9" .....	10"
Round at 45° .....	7-3/4" .....	8-1/2"
Rectangle at 90° .....	2"x16" - 9"x14" .....	2" x 18" - 10" x 15"
Rectangle at 45° .....	9"x7-3/4" .....	10" x 8-1/2"
Blade Size .....	1"x0.032"x119-1/2" .....	1.0" x 0.032" x 130"
Blade Wheel Diameter .....	13" .....	13"
Blade Wheel Speed .....	82, 132, 170, 235 SFPM .....	82, 132, 210, 330 SFPM
Motor(TEFC) .....	1-1/2 HP, 1 Ph 115/230V .....	2HP, 1Ph, 230V
.....	Prewired 115V .....	230V only
Lowered Height .....	41" .....	43"
Raised Height .....	65" .....	69"
Bed Height .....	25" .....	25"
Overall Dimensions (approx.) .....	65"L x 28"W .....	70"L x 31"W
Net Weight (approx.) .....	625 lbs. ....	776 lbs.
Shipping Weight (approx.) .....	704 lbs. ....	864 lbs.

**Table of Contents**

Uncrating and Cleanup .....	1
Installation .....	1
Assembly .....	1-2
Electrical Connections .....	3
Controls .....	3
Prior To Operation .....	4
Adjusting Vise Square to Blade .....	5
Changing Blade Speeds .....	5
Adjusting Feed Rate .....	6
Changing Blades .....	6
Blade Tracking Adjustment .....	7
Automatic Shut-Off Adjustment .....	8
Thrust Roller Adjustment .....	8
Guide Roller Adjustment .....	9
Bow Weight Adjustment .....	9
Vise Adjustment .....	10
Maintenance .....	10
Lubrication .....	10-11
Parts Breakdown .....	12-14
Parts List .....	15-23
Electrical Schematic .....	24-25

The specifications in this manual are given as general information and are not binding. JET Equipment and Tools reserves the right to effect, at any time and without prior notice, changes or alterations to parts, fittings, and accessory equipment deemed necessary for any reason whatsoever.

## Uncrating and Cleanup

**Note:** Read and understand the entire manual before attempting setup or operation.

1. Finish uncrating the saw and inspect for damage. Should any have occurred, contact your local distributor.
2. Remove all bolts attaching machine to shipping base.
3. Leave packing material between vice clamps and saw head intact until bandsaw has been lifted to its final position.
4. Clean all rust protected surfaces with kerosene or diesel oil to remove protective coating. Do not use gasoline, paint thinner, mineral spirits, etc. These may damage painted surfaces.
5. Lubricate all slideways with SAE 10W oil.

## Installation

For best performance, the bandsaw should be located on a solid and level foundation. Allow room for servicing and for moving large stock around the bandsaw when deciding a location for the machine.

1. Using lifting straps that are isolated from the bandsaw's finished surfaces, lift machine place in desired location. See figure 1 for strap placement.
2. Install four leveling bolts with lock nuts on both sides of the base as shown in the parts breakdown on page 12 - items #2 and #3.
3. Place a level on the table surface and check side to side and front to back.
4. Adjust leveling screws until machine is level in both directions and tighten locking nuts.

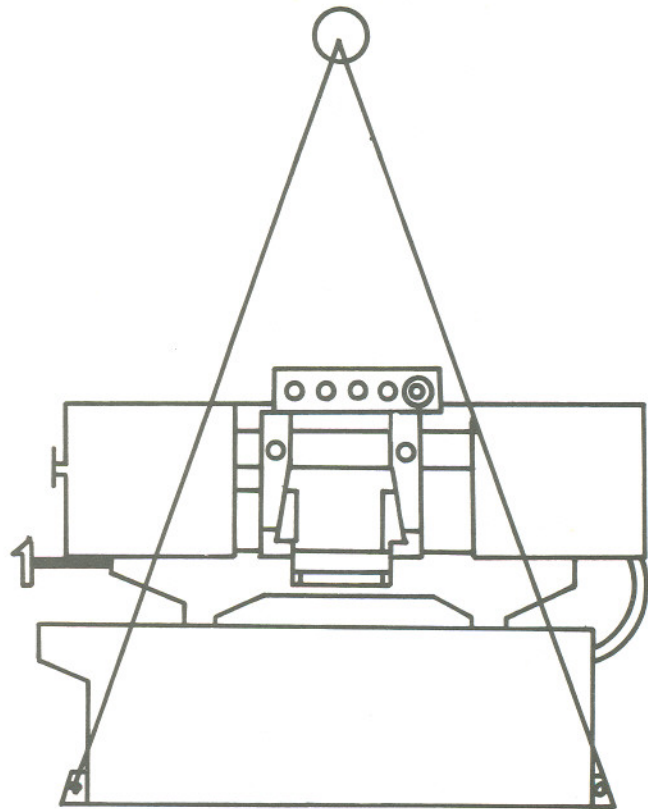

Fig. 1

## Assembly

1. Unbolt the motor assembly from the shipping crate bottom.
2. Remove nut and washer from the motor support shaft.

3. Remove shaft (A- Fig. 2) from the motor mount bracket.
4. Carefully lift motor and line up holes in the motor mounting plate and the motor bracket.
5. Slide motor support shaft into motor mount bracket to hold the motor in place.
6. Fasten shaft with nut and washer.
7. Loosen strain relief nut on the motor junction box. Remove the junction box cover. Insert wire through strain relief and wire to the terminal strip using the diagram on the junction box cover. Tighten the strain relief nut and replace the junction box cover.

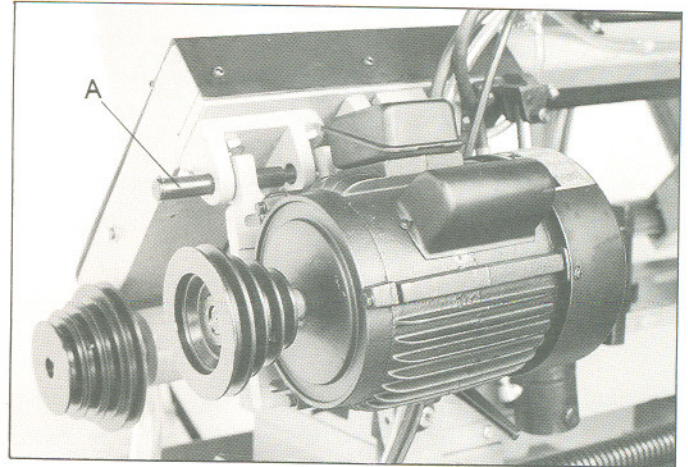

Fig. 2

Remove two hex cap bolts and washers

8. (A, Fig. 3) from the right side of the saw arm.
9. Slide belt cover (B, Fig. 3) around pulley shafts and attach to saw with two hex cap bolts and two washers.
10. Lift motor and place v-belt around both pulleys. Lower motor.
11. Tension the v-belt by pushing down on the motor and tightening the lock handle on the motor tilt plate. Correct tension is achieved when finger pressure between the two pulleys causes approximately a 1/2" deflection. See Figure 4.
12. Close pulley cover door and fasten with lock knob.
13. Fasten work stop rod (#17 - page 12) to saw bed (#11) by inserting into bed and turning clockwise until tight. Place work stop bracket (#16) onto stop rod (#17) and tighten lock handle (#20). Attach stop screw (#19) to stop bracket (#16) with lock handle (#18) and tighten.

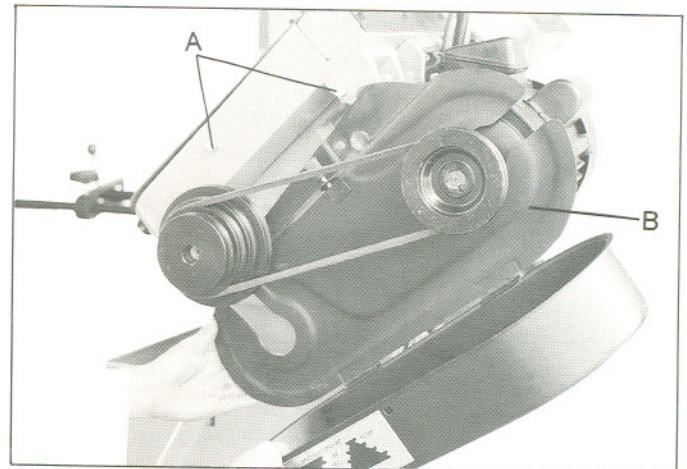

Fig. 3

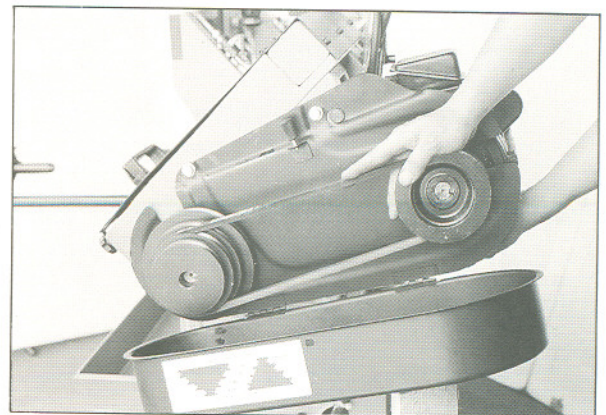

Fig. 4

## Electrical Connections

 **WARNING**

All electrical connections must be done by a qualified electrician! Failure to comply may result in serious injury!

 **WARNING**

Disconnect machine from the power source before changing any voltage components! Failure to comply may cause serious injury!

The HBS-916W bandsaw is rated at 115/230V, 1Ph. and is prewired 115 volt from the factory. The HBS1018W is rated at 230V, 1Ph. only. Confirm power available at the saw's location is the same as the saw is wired. To switch the HBS-916W from 115V to 230V, the following items will have to be changed:

- **Main Motor** - follow diagram inside junction box cover.
- **Coolant Pump** - Remove chip pan on front of saw, remove junction box cover on pump, and follow diagram inside junction box cover.
- **Control Transformer** - Open electrical panel on rear of base and switch primary wire on transformer from 115V to 230V.

Machine must always be correctly grounded.

**Note:** The power cord end will have to be changed to one that is rated 230V when changing to the higher voltage.

### Controls - Figure 5

- Power Indicator Light (A)** - lit whenever machine is running.
- Start Button (B)** - depress to start bandsaw.
- Emergency Stop Button (C)** - depress to immediately stop all machine functions.
- Coolant Switch (D)** - Turn arrow to "I" to turn on flow of coolant. Turn arrow to "O" to stop flow of coolant.

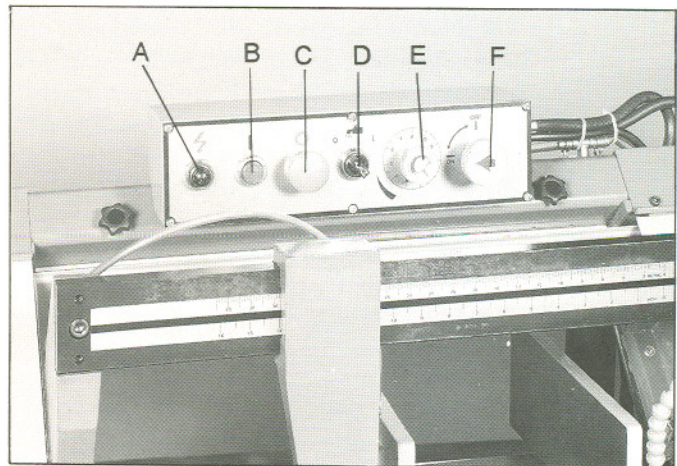

Fig. 5

- E. **Cutting Pressure Control (E)** - turn clockwise to decrease cutting pressure. Turn counter-clockwise to increase cutting pressure.
- F. **Hydraulic On-Off Valve (F)** - turns hydraulic cylinder on and off.

### **Prior to Operation**

1. Check blade tooth direction matches diagram on blade guides.
2. Check to see that blade is properly seated on wheels after applying correct tension (approximately 25,000 lbs.).
3. Set blade holder guides for approximately .003" to .005" clearance between the guides and blade.
4. Check for slight clearance between back up rollers and back of blade.
5. Position blade guides as close to work piece as possible.
6. Select proper speed and feed rate for material being cut. See speed selection chart found in the enclosed "Guide to Bandsawing" booklet supplied with this saw.
7. Material to be cut must be securely held in vise.
8. Check to see that coolant level is adequate and turn on coolant pump if material to be cut requires it. Machine should be filled with four gallons of the proper coolant mixture. Follow the directions on the product makers label and fill the coolant tank through the chip tray area.
9. Do not start cut on a sharp edge.
10. **Keep machine lubricated.** See "Lubrication" section.



## Adjusting Vise Square to the Blade

1. **Disconnect the machine from the power source.**
2. Place a machinist's square on the table against the blade and the vise. The square should lie along the entire length of the vise and blade without a gap.
3. If adjustment is necessary, loosen bolts holding the vise and adjust vise so square lines up properly. Tighten bolts.
4. Connect machine to the power source.

## Changing Blade Speeds

 **WARNING**

**Disconnect the machine from the power source before making any repair or adjustment! Failure to comply may cause serious injury!**

1. **Disconnect machine from the power source.**
2. Open pulley cover by supporting the belt cover with one hand while removing the belt cover lock knob with the other. Lower guard gently to its full open position.
3. Support motor with one hand while loosening lock handle (A - Fig. 6). Lower motor gently.
4. Position belt in grooves according to the speed selection chart.
5. Tension the v-belt by pushing down on the motor and tightening the lock handle on the motor tilt plate. Correct tension is achieved when finger pressure on the belt between the two pulleys causes approximately a 1/2" deflection.
6. Close pulley cover and fasten.
7. Connect machine to the power source.

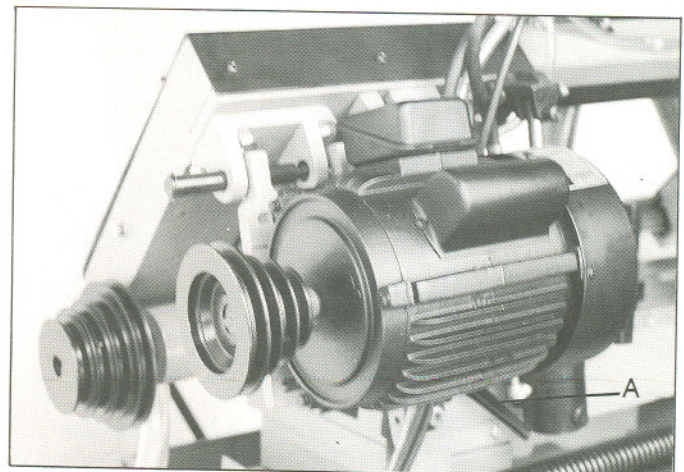

Fig. 6

## Adjusting Feed Rate

Rate of feed is adjusted by turning the cutting pressure control knob on the control panel. Rate of feed is important to bandsaw performance; excessive pressure may break the blade or stall the saw. Insufficient pressure rapidly dulls the blade.

Material chips or shavings are the best indicator of proper speed and pressure. The ideal chip is thin, tightly curled, and warm to the touch. Chips that range from golden brown to black indicate excessive force. Blue chips indicate extreme heat from too high a band speed which will shorten blade life. Thin or powdered chips indicate insufficient feed pressure.

A detailed explanation on feed rate can be found in the enclosed "Guide to Band Sawing" published by American Saw and Manufacturing Company. Reprinted by permission.

## Changing Blades

### WARNING

**Disconnect machine from the power source before making any adjustments or repairs! Failure to comply may result in serious injury!**

1. **Disconnect machine from power source.**
2. Raise saw arm approximately 6". Hold saw arm in place by closing cutting pressure control valve. Remove screw (#145), washer (#146), and brush (#147) from the wire brush post (#148) as shown on page 13.
3. Open both wheel covers and clean chips out of both wheel housings. Loosen two lock knobs and remove upper blade guard.
4. Release blade tension by turning blade tensioning handwheel (A - Fig. 7) counter-clockwise until blade is free.
5. Loosen lock knob and slide left blade guide arm (B) to the right as far as possible.
6. Remove old blade from both wheels and out of each blade guide.  **Caution:** Even dull

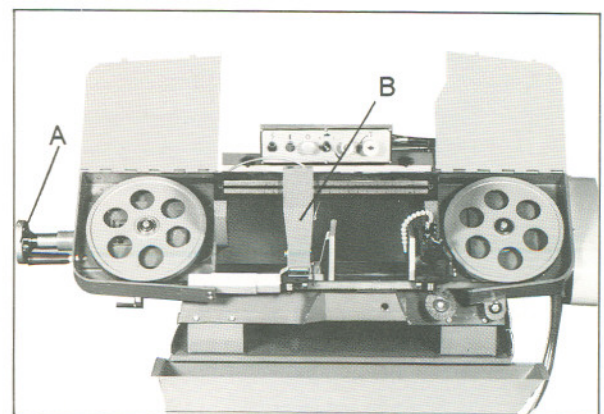

Fig. 7

blades are sharp to the skin! Use extra caution handling bandsaw blades!

7. Install new blade making sure teeth are pointed downward in the proper cutting direction. If necessary, turn blade inside out.
8. Position blade on band wheels and tighten just enough to hold blade on wheels. Make sure back of blade rests lightly against the wheel flange of both wheels. Twist blade slightly to allow it to slip into guides.
9. Tension blade to approximately 25,000 lbs. of blade tension, as indicated on the blade tension indicator found on the tension wheel shaft housing.
10. Attach wire brush to the wire brush post with screw and washer. Adjust wire brush post so that brush just comes into contact with blade teeth.
11. Close all covers and guards and fasten securely. Connect machine to power and run freely for approximately two minutes.
12. Turn power off and re-check blade tension and wire brush adjustment. If further adjustment is necessary, disconnect saw from power source, make adjustments, and re-connect to power.

## Blade Tracking Adjustment

Blade tracking has been set at the factory and should require no adjustment. If a tracking problem occurs, adjust the machine as follows:



### WARNING

**Tracking adjustment is done with the wheel covers open to observe the blade. Use extreme caution so as not to come into contact with the blade!**

Since tracking can only be adjusted while machine is running, it is suggested that this adjustment be accomplished by qualified personnel that are familiar with this type of adjustment and the dangers associated with it.

1. **Disconnect machine from the power source.**
2. Raise saw arm to its highest position and close cutting pressure control valve to hold saw arm in place.
3. Locate tracking adjustment plate on the back side of the driven blade wheel.
4. Loosen the three bolts (A - Fig. 8) located on the top of the tracking nuts.
5. Tracking adjustment is accomplished by either loosening or tightening three adjusting nuts (B - Fig. 8).
6. Tracking is set properly when the back of the blade lightly touches the wheel flange. **Note:** over-tracking (allowing blade back to rub hard against wheel flange) will damage the blade wheels and blade.
7. Tighten locking bolts (A) once properly tracking is completed.
8. Connect machine to the power source.

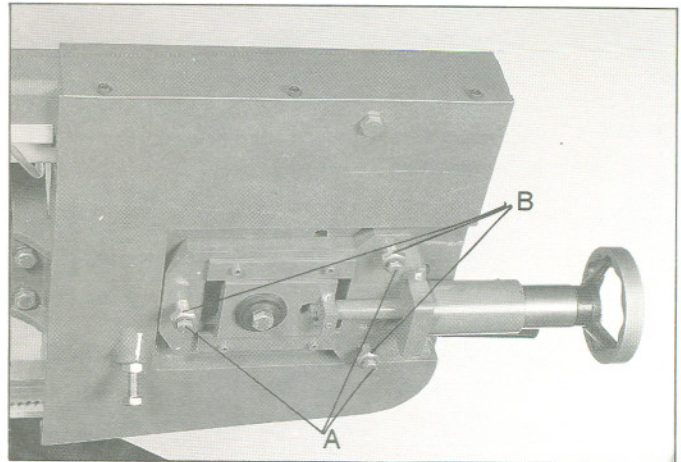

Fig. 8

### Automatic Shut-Off Adjustment

The motor should shut off immediately after the blade has cut through the material and just before the head comes to rest on the horizontal stop bolt. If the machine continues to run after the work piece has been fully cut, locate and adjust the micro switch mounting plate down. If the machine shuts off before the work piece has been completely cut, move the micro switch mounting plate up.

### Thrust Roller Adjustment

1. **Disconnect machine from the power source.**
2. Loosen two hex socket cap screws (A - Fig. 9). **Note:** Left guide roller has two hex socket cap screw; right guide roller has one (HBS-916W only) The HBS-1018W has two screws on each guide..
3. Move guide seat (B) up or down until a clearance of .003" to .005" between back of blade and thrust roller is obtained.

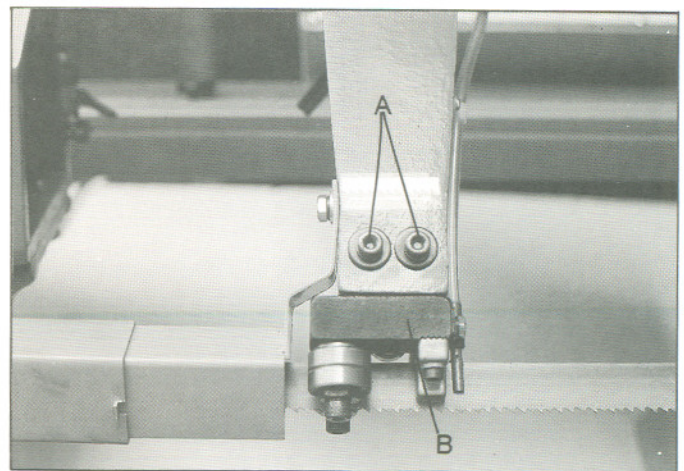

Fig. 9

4. Tighten two hex socket cap screws (A).
5. Repeat for other blade guide assembly.
6. Connect machine to power source.

## Guide Roller Adjustment

1. **Disconnect machine from the power source.**
2. Loosen blade guides (A - Fig. 10) by loosening screws (B). Slide blade guides away from blade.
3. Loosen locking screws (C) by using a hex wrench.
4. Adjust the eccentric bushings with a combination wrench until the ball bearings are snug to the blade. Note: blade should travel freely up and down between the ball bearings. Do not pinch the blade.
5. Tighten locking screws (C).
6. Slide blade guides back into contact with blade and tighten screws (B).
7. Connect machine to the power source.

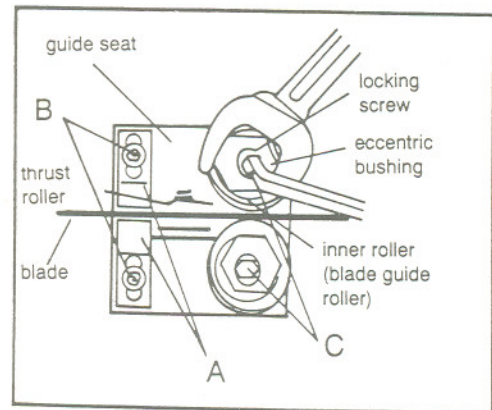

Fig. 10

## Bow Weight Adjustment

Bow weight is one of the most important adjustments of the saw. If the bow weight is not set properly, one can expect poor performance, crooked cuts, tooth stripping, stalling, and the blade popping off the blade wheels. The hydraulic feed rate unit will not compensate for improper bow weight. Bow weight has been set at the factory and should not need any adjustment. If adjustment is necessary:

1. **Disconnect the machine from the power source.**
2. Turn hydraulic valve to on (F - Fig. 5)
3. Turn cutting pressure control valve (E - Fig. 5) counter-clockwise until it stops.

1. Place one end of a fish-type scale under the blade tension handle and lift the saw with the other end. The scale should indicate approximately 18-20 lbs. for the HBS-916W. For the HBS-1018W, it should indicate 22-24 lbs.
2. Adjust tension to approximately 18-20 lbs. (or 22-24 lbs.) by turning the adjustable C-bolt found at the end of the coil spring on the rear of the bandsaw.
3. Connect the machine to the power source.

### Vise Adjustment

To position the moveable vise jaw:

1. Turn vise handwheel (A - Fig. 11) 1/2 turn counter-clockwise.
2. Move rack block (B - Fig. 11) to desired location by sliding along the bed. Place the rack block onto the rack.
3. Turn the handwheel to tighten the vise.

To adjust the vise for angle cutting:

1. Loosen bolts and move vise jaw (C-Fig11) to desired location.
2. Set the vise to desired angle, reinstall nuts and Tighten the nut and bolt assemblies.
3. Adjust the movable vise parallel to the fixed vise by loosening bolt (D-Fig.11) adjusting to parallel and tightening bolt.

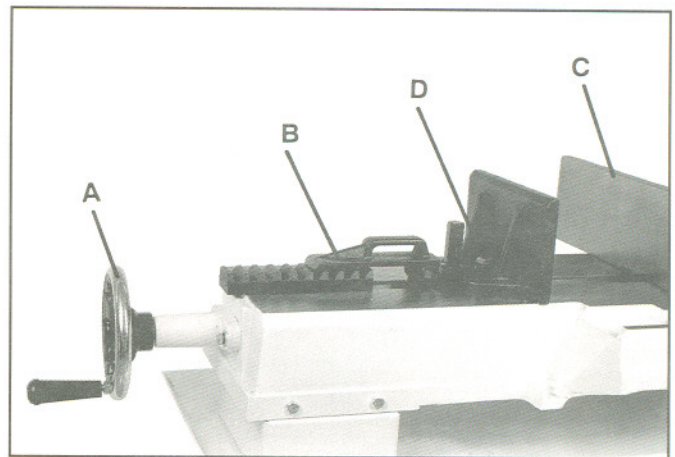

Fig. 11

### Maintenance

Keep the band saw and the motor clean.

### Lubrication

All ball bearings are permanently lubricated and sealed. They require no further lubrication.

The gear box lubricant should be changed after the first 50 hours of operation. Change lubricant from then on every 250 hours of operation.

To check level of gear box lubricant, place saw arm in down position and allow a few minutes to pass so that oil drains down. Check level in sight glass on side of gear casing. Correct level is the dot in the middle of sight glass.

To change gear box lubricant:

1. Disconnect machine from the power source.
2. Open drain plug and allow lubricant to drain completely. Drain plug may be found on lower front of gear case under right wheel cover. Remove drain plug with a hex wrench.
3. Replace drain plug.
4. Remove filler cap (A - Fig. 12) and fill gear box with Mobil DTE® Oil Heavy Medium until level reaches dot in middle of sight glass.
5. Replace filler cap.
6. Connect machine to the power source.

Use a light machine oil to lubricate all other moving parts as needed.

A detailed explanation on blade selection and blade problems and their solutions can be found in the enclosed "Guide to Band Sawing" published by American Saw and Manufacturing Company. Used by permission.

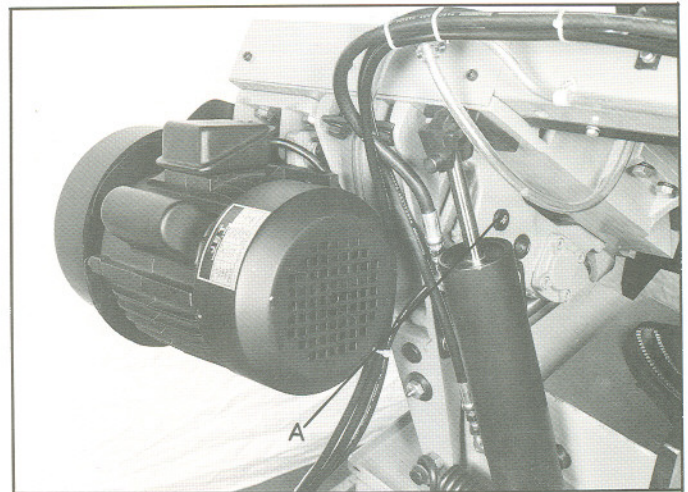
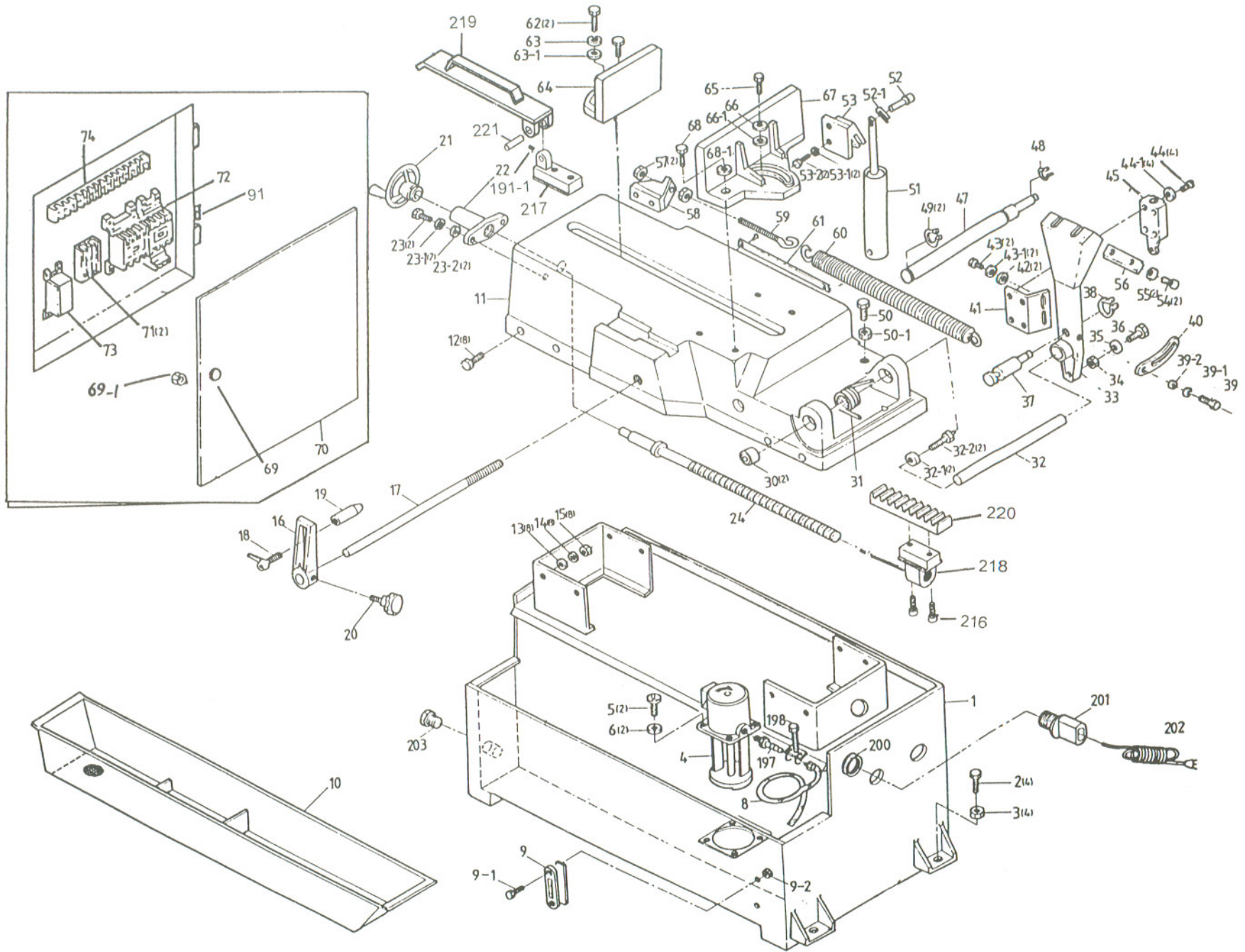
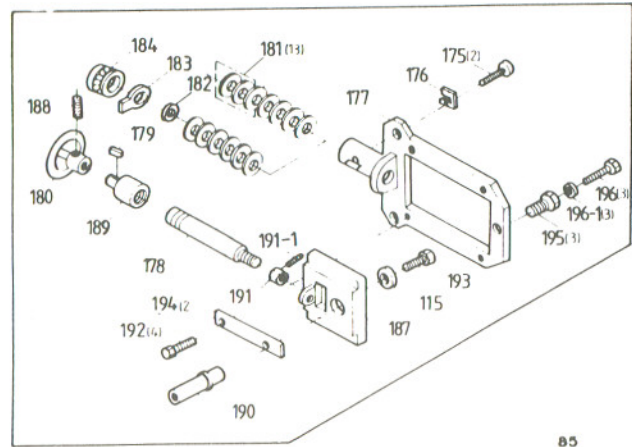

Fig. 12

Base and Bed Assembly







**Saw Arm Assembly**

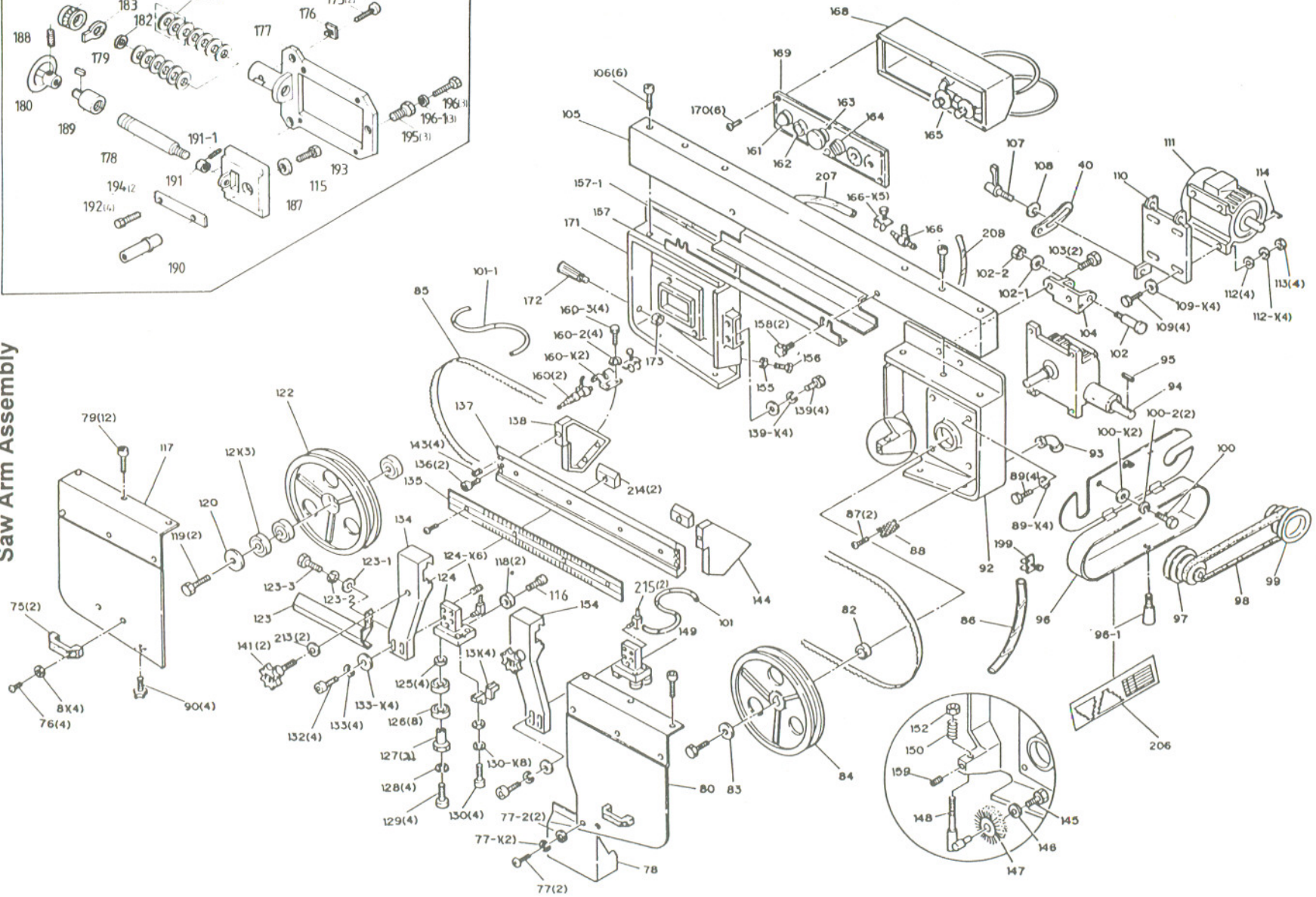

**HBS 1018W**

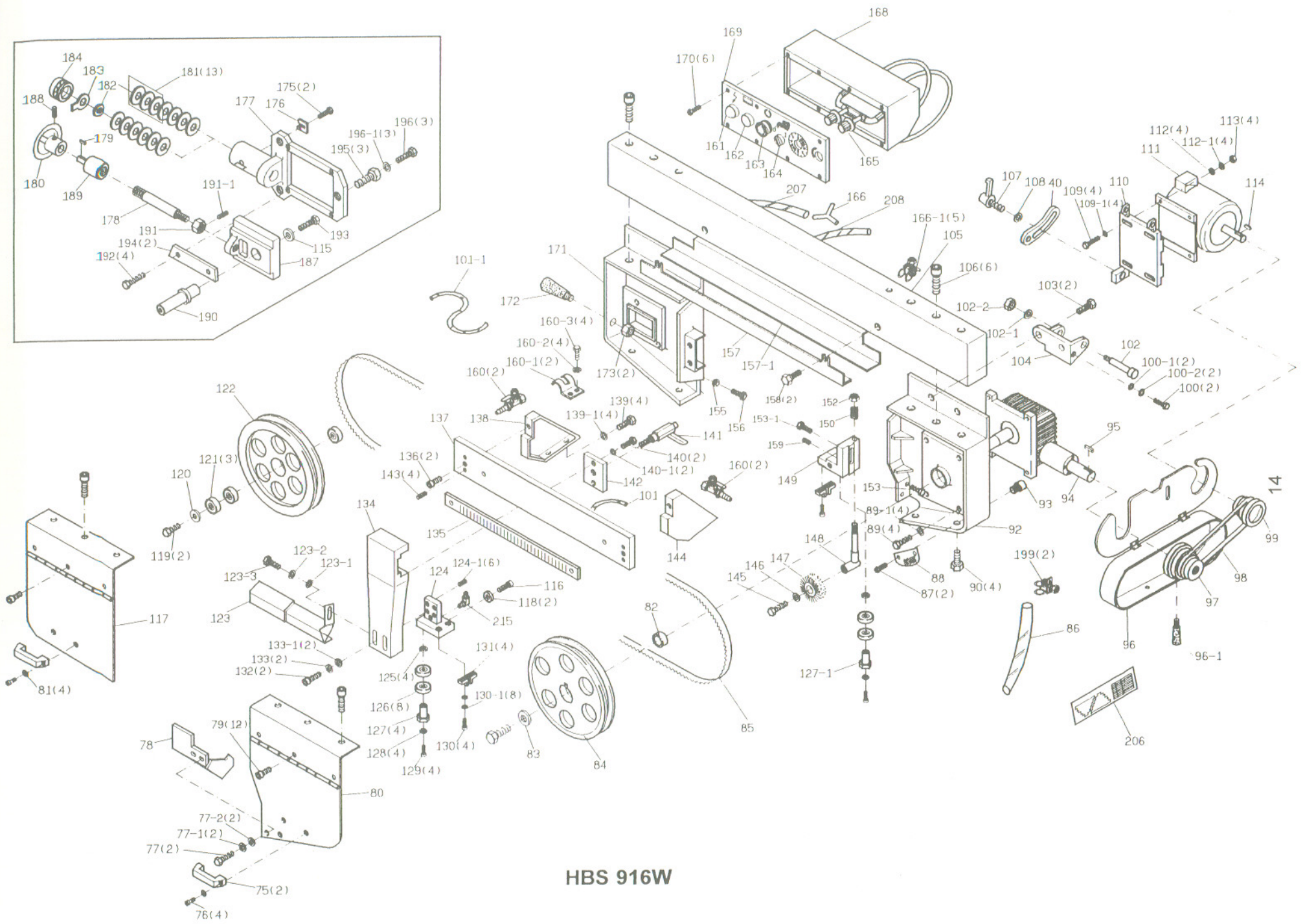

HBS 916W

## Parts List for the HBS-916W/-1018W Bandsaws

Index No.	Part No.	Description	Size	Qty.
1	HBS916W-01	Base (S/N 8081108 and lower)		1
	HBS916W-01A	Base (S/N 8081109 and higher)		1
	HBS1018W-01	Base (S/N 808718 and lower)		1
	HBS1018W-01A	Base (S/N 808719 and higher)		1
2	TS-1492071	Hex Cap Bolt	M12x70	4
3	TS-1540081	Hex Nut	M12	4
4	HBS916W-CP	Coolant Pump		1
5	TS-1531051	Pan Head Screw	M6x16	2
6	TS-1551061	Lock Washer	M6	2
8	HBS916W-08	Hose		1
9	HBS916W-09	Coolant Gauge		1
9-1	TS-1491041	Hex Cap Bolt	M10X30	2
9-2	TS-1540071	Hex Nut	M10	2
10	HBS916W-10	Chip Tray		1
	HBS1018W-10	Chip Tray		1
11	HBS916W-11	Bed (S/N 8081108 and lower)		1
	HBS916W-11A	Bed (S/N 8081109 and higher)		1
	HBS1018W-11	Bed (S/N 808718 and lower)		1
	HBS1018W-11A	Bed (S/N 808719 and higher)		1
12	TS-1490051	Hex Cap Bolt	M8x30	8
13	TS-1550061	Washer	M8	8
14	TS-1551081	Lock Washer	M8	8
15	TS-1540061	Hex Nut	M8	8
16	HBS916W-16	Stop Bracket		1
17	HBS916W-17	Stop Rod		1
18	HBS916W-18	Lock Handle		1
19	HBS916W-19	Work Stop		1
20	HBS916W-20	Lock Knob		1
21	HBS916W-21	Hand Wheel Assembly		1
	HBS1018W-21	Hand Wheel Assembly		1
22	HBS916W-22	Lead Screw Seat		1
	HBS1018W-22	Lead Screw Seat		1
23	TS-1490051	Hex Cap Bolt	M8x30	2
23-1	TS-1551061	Lock Washer	M8	2
23-2	TS-1550061	Washer	M8	2
24	HBS916W-24	Lead Screw (S/N 8081108 and lower)		1
	HBS916W-24A	Lead Screw (S/N 8081109 and higher)		1
	HBS1018W-24	Lead Screw (S/N 808718 and lower)		1
	HBS1018W-24A	Lead Screw (S/N 808719 and higher)		1
30	HK-2516-2RS	Needle Bearing		2
31	HBS916W-31	Torsion Spring		1
	HBS1018W-31	Torsion Spring		1
32	HBS916W-32	Pivot Shaft		1
32-1	TS-1550041	Washer	M12	2
32-2	HBS916W-32-2	Bolt w/ Zerk Fitting		2
33	HBS916W-33	Pivot Bracket		1
	HBS1018W-33	Pivot Bracket		1

34	TS-1540081	Nut	M12	1
35	TS-1550081	Washer	M12	1
36	TS-1492041	Hex Cap Bolt	M12x40	1
37	HBS916W-37	Torsion Spring Shaft		1
38	HBS916W-38	C-Ring	S-22	1
39	TS-1490041	Hex Cap Bolt	M8x25	1
39-1	TS-1551081	Lock Washer	M8	1
39-2	TS-1550061	Washer	M8	1
40	HBS916W-40	Motor Tilt Plate		1
	HBS1018W-40	Motor Tilt Plate		1
41	HBS916W-41	Limit Switch Plate		1
42	TS-1550061	Washer	M8	2
43	TS-1490031	Hex Cap Bolt	M8x20	2
43-1	TS-1551081	Lock Washer	M8	2
44	TS-1482021	Hex Cap Screw	M6x12	4
44-1	TS-1441041	Washer	M6	4
45	HBS916W-45	Limit Switch		1
47	HBS916W-47	Cylinder Pin		1
	HBS1018W-47A	Cylinder Pin		1
48	HBS916W-48	C-Ring	S-20	1
49	HBS916W-49	C-Ring	S-25	2
50	TS-1491041	Hex Cap Bolt	M10x30	1
50-1	TS-1540071	Hex Nut	M10	1
51	HBS916W-51	Hydraulic Cylinder Assembly		1
	HBS1018W-51	Hydraulic Cylinder Assembly		1
52	HBS916W-52	Cylinder Pin		1
52-1	HBS916W-52-1	Pin		1
53	HBS916W-53	Hydraulic Mounting Plate - Top		1
	HBS1018W-53	Hydraulic Mounting Plate - Top		1
53-1	TS-1551071	Lock Washer	M10	2
53-2	TS-1491041	Hex Cap Bolt	M10x30	2
54	TS-1492051	Hex Cap Bolt	M12x50	2
55	TS-1550081	Washer	M12	2
56	HBS916W-56	Plate		1
57	TS-0561051	Hex Nut	1/2"	2
58	HBS916W-58	Spring Bracket		1
59	HBS916W-59	Adjustable C-Bolt		1
60	HBS916W-60	Spring		1
	HBS1018W-60	Spring		1
61	HBS916W-61	Angle Scale		1
62	TS-1492041	Hex Cap Bolt	M12x40	2
63	TS-1551081	Lock Washer	M12	1
63-1	TS-1550081	Washer	M12	2
64	HBS916W-64	Vise Jaw - left		1
65	TS-1492051	Hex Cap Bolt	M12x50	1
66	TS-1551081	Lock Washer	M12	1
66-1	TS-1550081	Washer	M12	1
67	HBS916W-67	Vise Jaw - right		1
68	TS-1492041	Hex Cap Bolt	M12x40	1
68-1	TS-1551081	Lock Washer	M12	1
69	TS-1503011	Hex Socket Cap Bolt	M6x8	4
69-1	HBS916W-69-1	Nut	M6	1
70	HBS916W-70	Electrical Panel Cover (S/N 8081108 and lower HBS-916W)		1
	HBS916W-70	Electrical Panel Cover (S/N 808718 and lower HBS-1018W)		1

.....	HBS916W-70A.....	Electrical Panel Cover (S/N 8081109 and higher HBS-916W).....	1
.....	HBS916W-70A.....	Electrical Panel Cover (S/N 808719 and higher HBS-1018W).....	1
71 .....	HBS916W-71 .....	Fuse Block.....	2
.....	HBS916W-71A.....	Fuse 3A.....	1
72 .....	HBS916W-72B.....	Magnetic Switch.....	1
.....	HBS1018W-72.....	Magnetic Switch.....	1
.....	HBS916W-72-1.....	Contactora (main motor).....	1
.....	HBS916W-72A-1.....	Overload Relay.....	1
.....	HBS916W-72A-2.....	Contactora (pump).....	1
73 .....	HBS916W-73A.....	Transformer.....	1
.....	HBS1018W-73.....	Transformer.....	1
74 .....	HBS916W-74.....	Terminal Strip.....	1
75 .....	HBS916W-75.....	Handle.....	1
76 .....	TS-1534051.....	Pan Head Screw.....	M6x16.....4
77 .....	TS-1482021.....	Hex Cap Bolt.....	M6x12.....2
77-1 .....	TS-1551041.....	Lock Washer.....	M6.....2
77-2 .....	TS-1550041.....	Washer.....	M6.....2
78 .....	HBS916W-78.....	Wire Brush Guard.....	1
79 .....	TS-1503011.....	Hex Socket Cap Screw.....	M6x8.....12
.....	HBS1018W-79A.....	Adjustable Bracket Mount - rear (1018W only - not shown).....	1
80 .....	HBS916W-80.....	Blade Wheel Cover - right.....	1
.....	HBS1018W-80A.....	Blade Wheel Cover - right.....	1
81 .....	TS-1550041.....	Washer.....	M6.....4
82 .....	HBS916W-82.....	Bushing.....	1
83 .....	HBS916W-83.....	Washer.....	1
84 .....	HBS916W-84.....	Drive Wheel.....	1
.....	HBS1018W-84A.....	Drive Wheel.....	14".....1
85 .....	.....	Blade (local purchase - 916W).....	1
.....	.....	Blade (local purchase - 1016W).....	1
86 .....	HBS916W-86.....	Hose.....	1
87 .....	TS-1533031.....	Pan Head Screw.....	M5x10.....2
88 .....	HBS916W-88.....	Filter Screen.....	1
89 .....	TS-1492031.....	Hex Cap Bolt.....	M12x35.....4
89-1 .....	TS-1551081.....	Lock Washer.....	M12.....4
90 .....	HBS916W-90.....	Lock Knob.....	4
91 .....	HBS916W-91.....	Hinge Pin.....	2
92 .....	HBS916W-92.....	Blade Wheel Box - right.....	1
.....	HBS1018W-92.....	Blade Wheel Box - right.....	1
93 .....	HBS916W-93.....	Connector.....	1
.....	HBS1018W-93.....	Connector.....	1
94 .....	HBS916W-94.....	Gear Box Assembly (can only order entire assembly).....	1
.....	HBS1018W-94.....	Gear Box Assembly (can only order entire assembly).....	1
95 .....	HBS916W-95.....	Key.....	7MM.....1
96 .....	HBS916W-96.....	Pulley Cover.....	1
.....	HBS1018W-96.....	Pulley Cover.....	1
96-1 .....	HBS916W-96-1.....	Lock Knob.....	1
97 .....	HBS916W-97.....	Gear Box Pulley.....	1
.....	HBS1018W-97.....	Gear Box Pulley.....	1
98 .....	VB-A39.....	V-Belt.....	1
.....	VB-A37.....	V-Belt.....	1
99 .....	HBS916W-99.....	Motor Pulley.....	1
.....	HBS1018W-99.....	Motor Pulley.....	1
100 .....	TS-1482031.....	Hex Cap Bolt.....	M8x16.....2
100-1 .....	TS-1550061.....	Washer.....	M8.....2

100-2	TS-1551061	Lock Washer	M8	2
101	HBS916W-101	Hose		1
101-1	HBS916W-101-1	Hose		1
102	HBS916W-102	Support Shaft		1
102-1	TS-1550081	Washer	M12	1
102-2	TS-1540081	Hex Nut	M12	1
103	TS-1492021	Hex Cap Bolt	M12x30	2
104	HBS916W-104	Motor Mount Bracket		1
105	HBS916W-105	Column		1
	HBS1018W-105A	Column		1
106	TS-1506011	Hex Socket Cap Screw	M12x20	6
107	HBS916W-107	Locking Handle		1
108	TS-1550061	Washer	8MM	1
109	TS-1490081	Hex Cap Bolt	M8x45	4
109-1	TS-1550061	Washer	M8	4
110	HBS916W-110	Motor Mount Plate		1
111	HBS916W-111	Motor (1-1/2 HP, 1Ph, 115/230V)		1
	HBS1018W-111	Motor (2 HP, 1Ph, 230V only)		1
	HBS916W-600250	Capacitor (not shown)		1
	HBS916W-111-2	Capacitor Cover (not shown)		1
	HBS1018W-111-1	Capacitor (not shown)		1
	HBS1018W-111-2	Capacitor Cover (not shown)		1
112	TS-1550061	Washer	M8	4
112-1	TS-1551061	Lock Washer	M8	4
113	TS-1540061	Hex Nut	M8	4
114	HBS916W-114	Key	7MM	1
115	TS-1550081	Washer	M12	1
116	TS-1504041	Hex Socket Cap Screw	M8x20	1
117	HBS916W-117	Blade Wheel Cover - left		1
	HBS1018W-117A	Blade Wheel Cover - left		1
118	BB-608VV	Ball Bearing		2
119	TS-1492011	Hex Cap Bolt	M12x25	2
120	TS-1550081	Washer	M12	1
121	BB-6205Z	Ball Bearing		3
122	HBS916W-122	Idler Wheel		1
	HBS1018W-122A	Idler Wheel		1
123	HBS916W-123	Blade Guard		1
	HBS1018W-123A	Blade Guard		1
123-1	TS-1550061	Washer	M8	1
123-2	TS-1551061	Lock Washer	M8	1
123-3	TS-1490021	Hex Cap Bolt	M8x16	1
124	HBS916W-124	Guide Bracket - left		1
	HBS916W-124A	Guide Bracket Assembly - left		1
	HBS1018W-124A	Guide Bracket Assembly - left		1
124-1	TS-1504031	Hex Socket Cap Screw (HBS-916W)	M8x16	3
	TS-1504031	Hex Socket Cap Screw (HBS-1018W)	M8x16	6
125	TS-1540061	Washer	M8	4
126	BB-6201VV	Ball Bearing		8
127	HBS916W-127	Eccentric Sleeve (outside) (HBS916W)		2
	HBS1018W-127	Eccentric Sleeve (outside) (HBA1018W)		2
127-1	HBS916W-127-1	Sleeve (inside-not show) (HBS916W)		2
	HBS1018W-127-1	Sleeve (inside-not show) (HBS1018W)		2

128	TS-1551061	Lock Washer	M8	4
129	TS-1504091	Hex Socket Cap Screw	M8x45	4
130	TS-1503071	Hex Socket Cap Screw	M6x30	4
130-1	TS-1550041	Washer	M6	8
131	HBS916W-131	Blade Guide		4
132	TS-1504081	Hex Socket Cap Screw (HBS-916W)	M8x40	2
	TS-1504081	Hex Socket Cap Screw (HBS-1018W)	M8x40	4
133	TS-1551081	Lock Washer (HBS-916W)	M8	2
	TS-1551081	Lock Washer (HBS-1018W)	M8	4
133-1	TS-1550081	Washer (HBS-916W)	M8	2
	TS-1550081	Washer (HBS-1018W)	M8	4
134	HBS916W-134	Adjustable Bracket		1
	HBS1018W-134A	Adjustable Bracket		1
135	HBS916W-135	Scale (1018W)		1
	HBS1018W-135	Dovetail Scale		1
136	TS-1505031	Hex Socket Cap Screw	M10x25	2
137	HBS916W-137	Slide		1
	HBS1018W-137A	Slide		1
138	HBS916W-138	Blade Bracket - left		1
	HBS1018W-138	Blade Bracket - left		1
139	TS-1492021	Hex Cap Bolt	M12x30	4
139-1	TS-551081	Lock Washer	M12	4
140	TS-1490041	Hex Cap Bolt (HBS-916W)	M8x25	2
140-1	TS-1551061	Lock Washer (HBS-916W)	M8	2
141	HBS916W-141	Knob		1
	HBS1018W-141	Knob		1
142	HBS916W-142	Plate		1
143	TS-1524021	Set Screw	M8x10	4
144	HBS916W-144	Blade Bracket - right		1
	HBS1018W-144	Blade Bracket - right		1
145	TS-1482011	Hex Cap Bolt	M6x10	1
146	TS-1550041	Washer	M6	1
147	HBS916W-147	Wire Brush		1
	HBS1018W-147	Wire Brush		1
148	HBS916W-148	Wire Brush Rod		1
	HBS1018W-148	Wire Brush Rod		1
149	HBS916W-149	Guide Bracket - right		1
	HBS1018W-149	Guide Bracket - right		1
	HBS916W-149A	Guide Bracket Assembly - right		1
	HBS1018W-149A	Guide Bracket Assembly - right		1
150	HBS916W-150	Spring		1
	HBS1018W-150	Spring		1
152	TS-1540071	Hex Nut	M10	1
153	TS-1504091	Hex Socket Cap Screw (HBS-916W)	M8x45	2
153-1	HBS916W-153-1	Hex Socket Cap Screw	M8x55	1
154	HBS1018W-154A	Adjustable Bracket - right (HBS-1018W)		1
155	TS-1540081	Hex Nut	M12	1
156	TS-1492061	Hex Cap Bolt	M12x60	1
157	HBS916W-157	Blade Guard		1
	HBS1018W-157A	Blade Guard		1
157-1	HBS1018W-157-1	Blade Guard - down		1
158	HBS916W-158	Lock Knob		1
159	TS-1523021	Set Screw (HBS-1018W)	M6x8	1
160	HBS916W-160	Adjusting Valve		2

160-1	... HBS916W-160-1	Clamp		1
160-2	... TS-1551041	Lock Washer	M6	4
160-3	... TS-1482021	Hex Cap Bolt	M6x12	4
161	... HBS916W-161A	Power Indicator Light		1
162	... HBS916W-162	Start Switch		1
163	... HBS916W-163	Stop Switch		1
164	... HBS916W-164	Pump Switch		1
165	... HBS916W-165S	Feed Control - Hydraulic On/Off Valve		1
	... HBS916W-165S-1	Speed Control Valve		1
	... HBS916W-165S-1-K	Knob for Speed Control Valve		1
	... HBS916W-165S-K	Knob for On/Off Valve		1
166	... HBS916W-166	Connecting Tube		1
166-1	... HBS916W-166-1	Hose Clamp		3
168	... HBS916W-168	Control Box		1
169	... HBS916W-169	Control Panel		1
170	... TS-1533031	Pan Head Screw	M5x10	6
171	... HBS916W-171	Wheel Box - left		1
	... HBS1018W-171	Wheel Box - left		1
172	... HBS916W-172	Handle		1
173	... TS-1540081	Hex Nut	M12	2
175	... TS-1533031	Pan Head Screw	M5x10	2
176	... HBS916W-176	Indicator Scale		1
177	... HBS916W-177	Slide Bracket		1
178	... HBS916W-178	Tension Shaft		1
179	... HBS916W-179	Key	5MM	1
180	... HBS916W-180	Handwheel		1
181	... HBS916W-181	Lock Washer	M22	13
182	... HBS916W-182	Flat Steel Washer		1
183	... HBS916W-183	Tension Indicator		1
184	... BB-51104	Thrust Bearing		1
187	... HBS916W-187	Slide		1
188	... TS-1524021	Set Screw	M8x10	1
189	... HBS916W-189	Extension Bar		1
190	... HBS916W-190	Wheel Shaft		1
191	... HBS916W-191	Nut w/Hole For Set Screw	M14	1
191-1	... TS-1523021	Set Screw	M6x8	1
192	... TS-1504051	Hex Socket Cap Screw	M8x25	4
193	... TS-1492011	Hex Socket Cap Screw	M12x25	1
194	... HBS916W-194	Gib		2
195	... HBS916W-195	Hex Cap Screw (re: HBS916W-196)		3
196	... HBS916W-196	Screw Assembly		3
196-1	... HBS916W-196-1	Lock Washer (re: HBS916W-196)		3
197	... HBS916W-197	Hose Fitting		1
198	... HBS916W-198	Hose Clamp		1
199	... HBS916W-199	Hose Clamp		2
	... HBS1018W-199	Hose Clamp		1
200	... HBS916W-200	Nut		1
201	... HBS916W-201	Strain Relief Fitting		1
202	... HBS916W-202	Power Cord		1
203	... HBS916W-203	Screw		1
204	... HBS916W-204	Name Plate		1
205	... HBS916W-205	Warning Label		1
206	... HBS916W-206	Speed Chart Label		1
207	... HBS916W-207	Hose		1



208	HBS916W-208	Hose		1
213	TS-1550071	Washer	M10	2
214	HBS1018W-214	Clamp		2
215	HBS916W-215	Cu Connector		1
	HBS1018W-215	Cu Connector		2
216	TS-1504051	Hex Socket Cap Screw	M8x25	2
217	HBS916W-217	Slide Bracket		1
218	HBS916W-218	Lead Screw Bracket		1
219	HBS916W-219	Rack Block		1
	HBS1018W-219	Rack Block		1
220	HBS916W-220	Rack		1
	HBS1018W-220	Rack		1
221	HBS916W-221	Pin		1

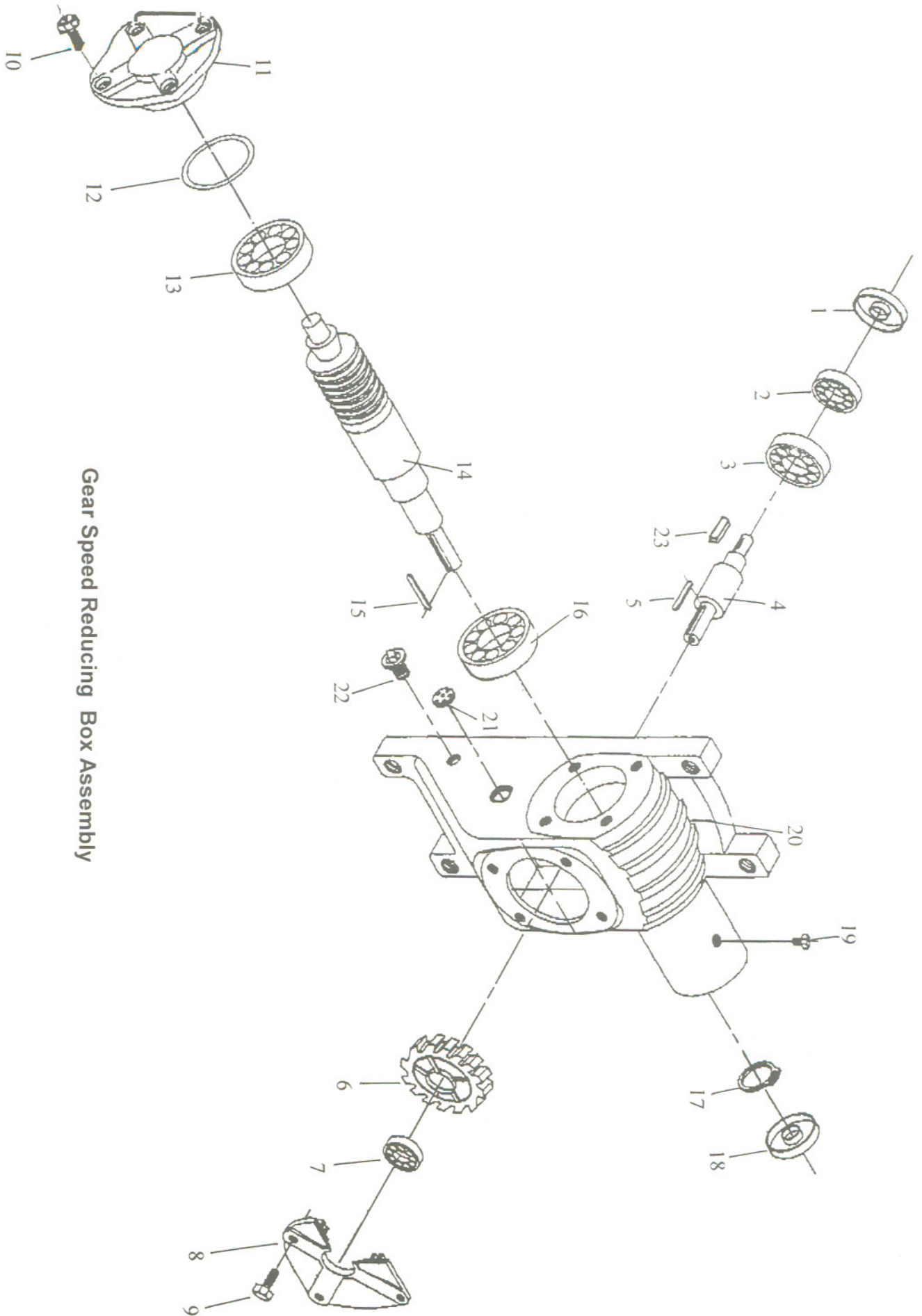

**Gear Speed Reducing Box Assembly**

## Parts List For The Gear Speed Reducing Box Assembly

Index No.	Part No.	Description	Size	Qty.
1	HBS916W-94-01	OIL SEAL	35x55X8	1
2	HBS916W-94-02	BEARING	30207	1
3	HBS916W-94-03	BEARING	6207	1
4	HBS916W-94-04	SHAFT		1
5	HBS916W-94-05	KEY	8x7x30	1
6	HBS916W-94-06	GEAR WHEEL		1
7	HBS916W-94-07	BEARING	6206	1
8	HBS916W-94-08	OUTPUT SHAFT COVER		1
9	HBS916W-94-09	OUTPUT HEX CAP SCREW	M10x20	4
10	HBS916W-94-10	INPUT HEX CAP SCREW	M8x20	4
11	HBS916W-94-11	INPUT SHAFT COVER		1
12	HBS916W-94-12	WASHER		1
13	HBS916W-94-13	BEARING	6025	1
14	HBS916W-94-14	INPUT SHAFT		1
15	HBS916W-94-15	KEY	7x7x60	1
16	HBS916W-94-16	BEARING	6205	1
17	HBS916W-94-17	C-RING	R52	1
18	HBS916W-94-18	OIL SEAL	25x52x8	1
19	HBS916W-94-19	VENT BOLT		1
20	HBS916W-94-20	GEAR BOX		1
21	HBS916W-94-21	OIL LENS		1
22	HBS916W-94-22	DRAW PLUG		1
23	HBS916W-94-23	KEY	7X7X45	4

1PH

# Electrical Schematic for the HBS-916W

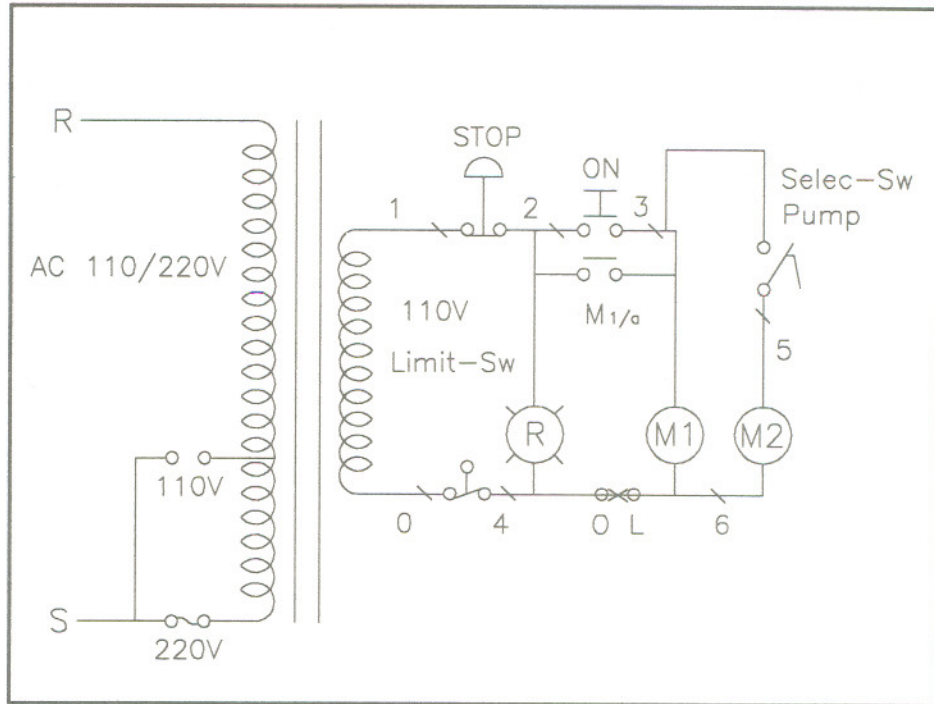

## Electrical Panel Layout

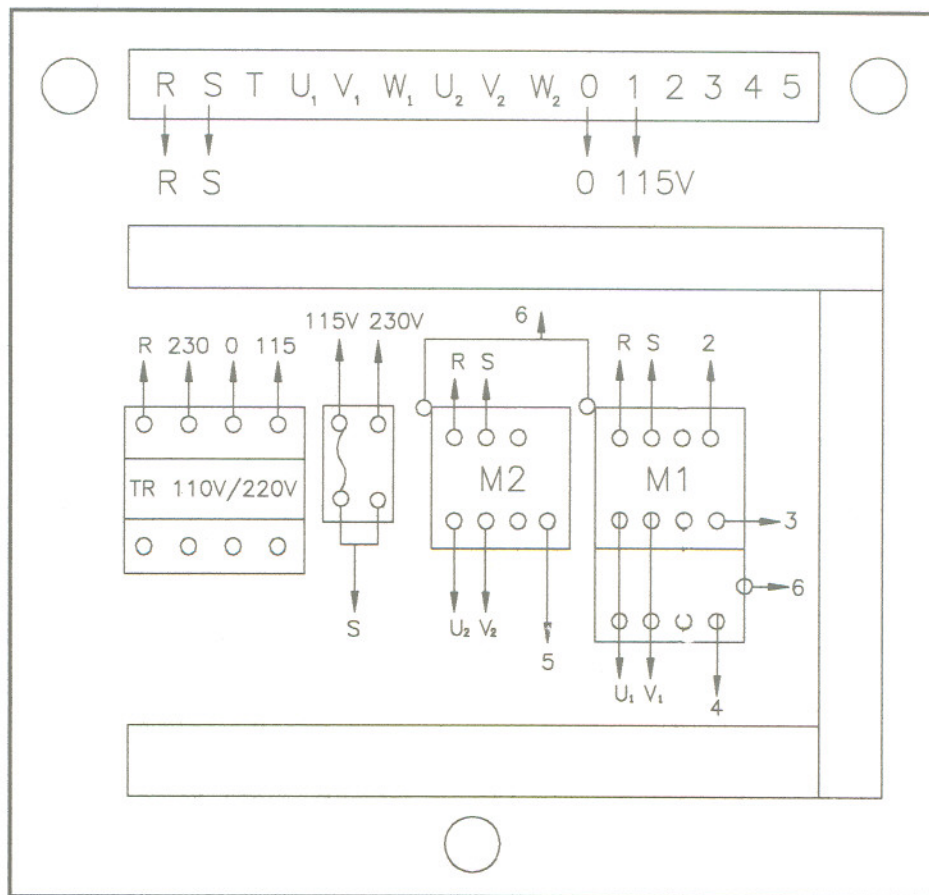

1PH

Electrical Schematic for the HBS-1018W

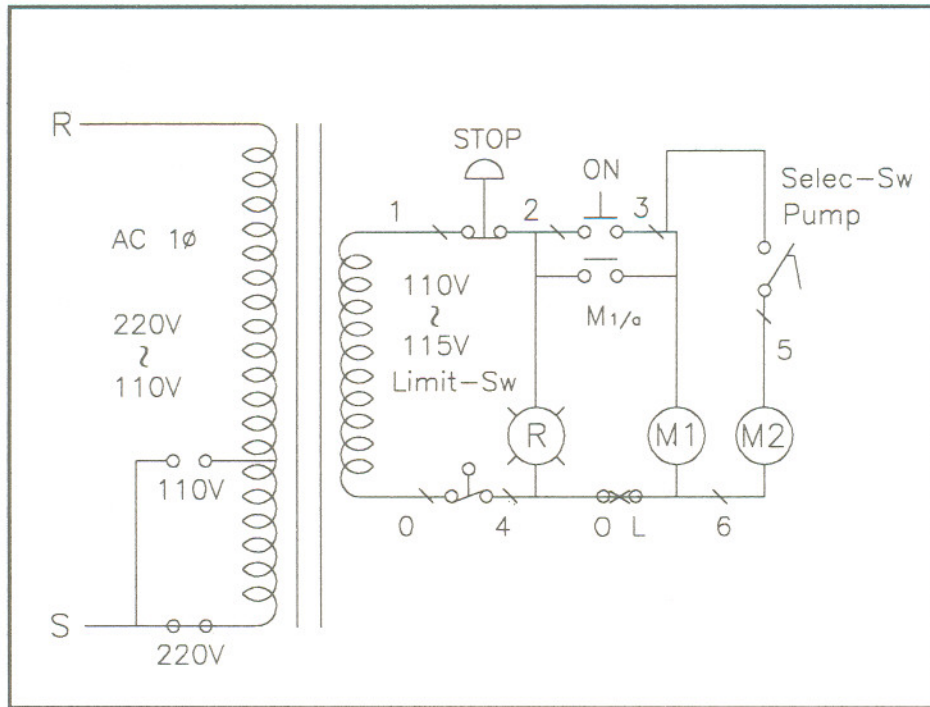

Electrical Panel Layout

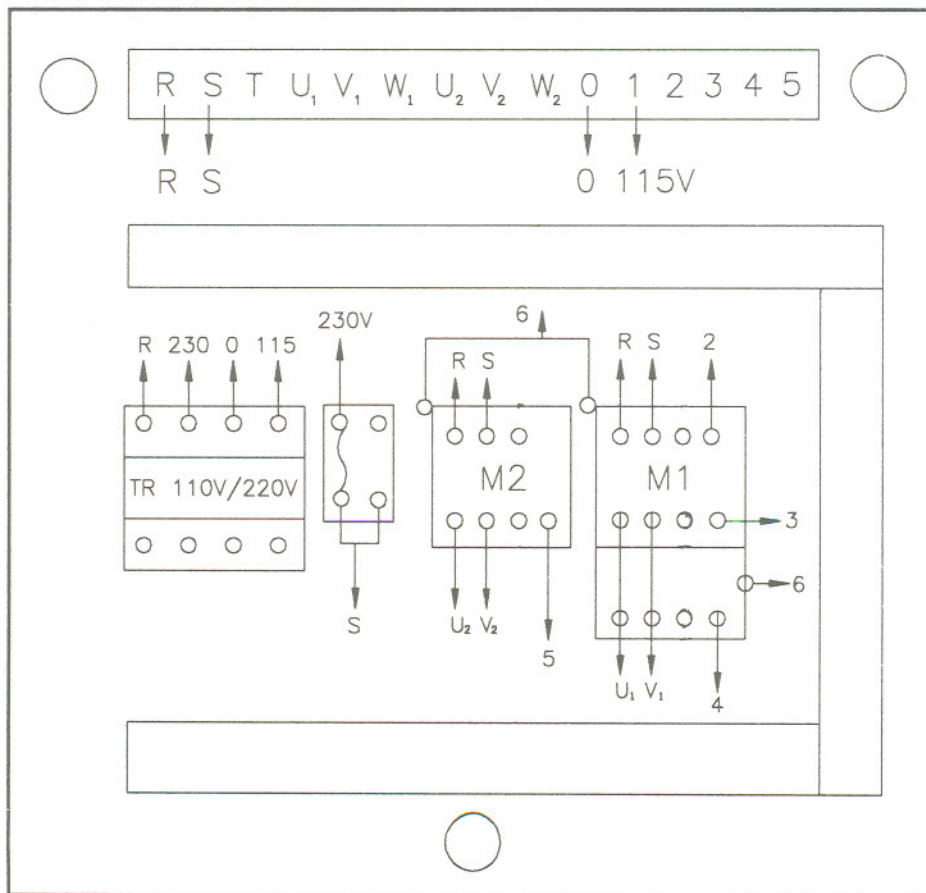









## Free Manuals Download Website

<http://myh66.com>

<http://usermanuals.us>

<http://www.somanuals.com>

<http://www.4manuals.cc>

<http://www.manual-lib.com>

<http://www.404manual.com>

<http://www.luxmanual.com>

<http://aubethermostatmanual.com>

Golf course search by state

<http://golfingnear.com>

Email search by domain

<http://emailbydomain.com>

Auto manuals search

<http://auto.somanuals.com>

TV manuals search

<http://tv.somanuals.com>