



D

EXCAVATORS

135D 225D LC





Well armed.

Whether it's urban renewal, interstate work, or underground utilities, the 135D and 225D LC will arm you for top productivity. They deliver impressive swing torque, drawbar pull, and lift capability, with low emissions and noise. Their reduced-tail-swing design allows them to rotate freely within a small radius, so they are more productive around obstacles or in confined spaces. Run long and hard, too, with rugged diesel engines certified to

EPA Tier 3 emissions, more efficient cooling systems, and beefier undercarriages delivering long-lasting durability. And with quieter, more spacious cabs offering ample legroom and noticeably more glass, comfort and visibility are unsurpassed. All the power, smoothness, ease of operation, and comfort you'd expect from John Deere excavators in a compact, easy-to-maneuver package.



Reduced tail swing allows operators to get closer to objects on congested jobsites, eliminating the need for a lot of handwork.

Extended engine and hydraulic oil-service intervals increase uptime and reduce daily operating costs.

Spacious cab combines more legroom and more glass for unsurpassed comfort and visibility.

Powerwise III™ engine/hydraulic management system maximizes power output, saves fuel, and delivers smooth multifunction hydraulic operation.

Fuel-efficient Tier-3-emission-certified diesels deliver power without compromise in all conditions.

Specifications	135D	225D LC
SAE Net Horsepower...	93 hp (69 kW)	159 hp (118 kW)
Operating Weight	32,747 lb. (14 854 kg)	53,936 lb. (24 487 kg)
Lift Capacity	5,984 lb.(2714 kg)	14,248 lb. (6469 kg)
Digging Depth	19 ft. 9 in. (6.02 m)	22 ft. (6.70 m)
Arm Breakout Force ...	12,942 lb. (57.6 kN)	22,924 lb. (102.0 kN)

Noise levels — and operator fatigue — have been significantly reduced. A noise-reducing muffler and isochronous high-idle speed help keep things quiet.

Need even more hydraulic capability? Equip your excavator with a high-pressure, high-flow auxiliary hydraulic package.

Three modes can be selected to match the engine rpm to the operating conditions and application. The new E mode for light-duty work reduces fuel consumption, without sacrificing productivity. The H/P (high-power) mode increases engine rpm to boost horsepower for working through tough spots. Engine rpm automatically returns to normal once the resistance is overcome.

With more horsepower, lift capacity, swing torque, and drawbar pull, you can expect big productivity out of the 135D and 225D LC.

On jobs where you need added finesse, best-in-class metering and superb multifunction operation give you the precise control you need.

Powerwise III perfectly balances engine performance and hydraulic flow for fast cycles and predictable operation. One work mode makes it easy to be productive in any application.



1. Reduced tail swing allows operators to worry less about what's behind them and focus on the business end of the machine. With fewer battered barricades, bent bushes, or scraped counterweights.

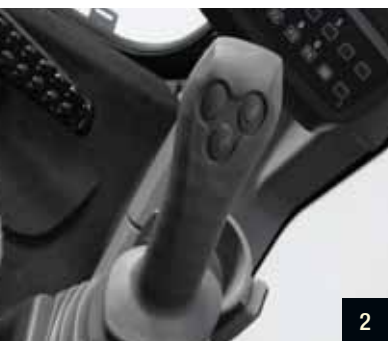

2. When extra hydraulic muscle is needed to overcome tough going, simply press the power-boost button (225D LC only) to break through.

3. When changing attachments, simply match the hydraulic flow to your attachment using the new LCD display monitor. No need to leave your seat.





Won't have trouble fitting in.

Running out of space on street jobs and other tight jobsites? Position yourself for more productivity. With reduced tail swing, you can work easily within one lane of traffic or get closer to objects — without damaging surroundings or your machine. And with faster hydraulics combined with outstanding lift capability, reach, and swing torque, you'll get more

done, faster. Control is smooth and effortless, with the Powerwise III engine/hydraulic management system delivering pinpoint metering with expected Deere finesse and precision. Numerous factory- and dealer-installed options are available, so you can equip your excavator to do just about anything. For the versatility you need to fit in even more work.



Saves your tail in more ways than one.

Reduced tail swing minimizes damage to the backside of the excavator. And its roomy, comfortable cab ensures your operators won't have to work their tails off either. There's more of everything they need to do their best, like substantially more legroom, generous storage, and virtually unrestricted visibility. Creature comforts abound, including

automatic climate control, AM/FM radio, 12-volt power port, hot/cold storage box for beverages, and available heated air-suspension seat. Your operators will also appreciate the things a John Deere excavator delivers less of — like noise, emissions, lever efforts, and productivity-robbing fatigue.



No shortage of storage here. There's a cup holder and even a hot/cold box that keeps beverages at just the right temperature.

Pushbuttons on the LCD monitor allow fingertip control of auxiliary hydraulic flow for operating attachments.

Convenient 12-volt port powers cell phones and other electronic devices.

Silicone-filled mounts effectively isolate operators from noise and vibration.

Intuitive, multi-language color LCD monitor provides: vital and general operating information including coolant temperature and fuel level; maintenance data, including preset schedules for replacing hydraulic oil and fuel filters; and onboard diagnostics of most sensors and switches for quick troubleshooting.

Deluxe-suspension multi-position seat has plenty of travel. It slides together or independent of the control console, so it won't cramp an operator's style.

1. A larger right-hand side window, narrow front cab posts, large overhead hatch, and numerous mirrors provide virtually unobstructed all-around visibility.
2. Automatic, high-velocity bi-level climate-control system with automotive-style adjustable louvers helps keep the glass clear and the cab comfortable.
3. Ergonomically correct short-throw pilot levers provide smooth, predictable fingertip control with less movement and effort.



Both the 135D and 225D feature fuel-efficient diesel engines that comply with the Tier 3 emission regulations, helping to preserve the environment.

Welded bulkheads within the boom resist torsional stress.

Oil-impregnated bushings enhance durability and extend grease intervals to 500 hours for the arm-and-boom joint and 100 hours for the bucket joint.

Thicker reinforced idler bracket ensures maximum durability, while preventing thrown tracks on rough terrain.

Reinforced resin thrust plates, grooved bushings, and thermal-coated bucket joints increase arm and boom lube intervals to 500 hours.



1

1. Box-section track frames, thick-plate single-sheet mainframe, and large swing bearing deliver rock-solid durability.



2

2. Tungsten-carbide coating on the all-important bucket-to-arm joint creates an extremely wear-resistant surface that won't compromise joint strength.

3. With large idlers, rollers, and strutted track links, the sealed and lubricated undercarriage delivers long and reliable performance.



3



4

4. Rigid, reinforced D-channel side frames resist impact, providing maximum cab and component protection.



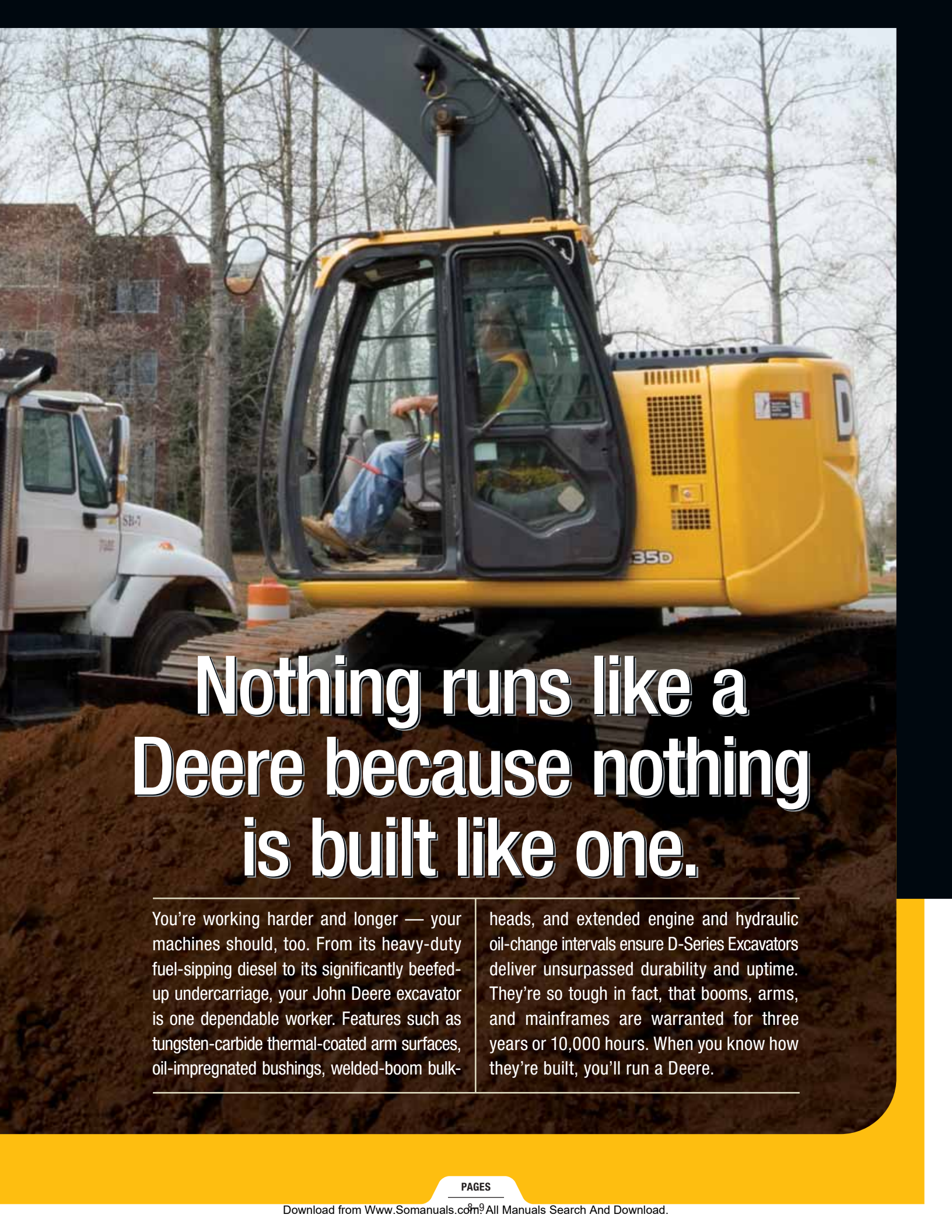

Nothing runs like a Deere because nothing is built like one.

You're working harder and longer — your machines should, too. From its heavy-duty fuel-sipping diesel to its significantly beefed-up undercarriage, your John Deere excavator is one dependable worker. Features such as tungsten-carbide thermal-coated arm surfaces, oil-impregnated bushings, welded-boom bulk-

heads, and extended engine and hydraulic oil-change intervals ensure D-Series Excavators deliver unsurpassed durability and uptime. They're so tough in fact, that booms, arms, and mainframes are warranted for three years or 10,000 hours. When you know how they're built, you'll run a Deere.

Large fuel tanks and 500- and 5,000-hour engine and hydraulic oil-service intervals help increase uptime and lower daily operating costs.

Auto-idle helps make the most of every precious drop of fuel by automatically reducing engine speed when pilot levers are momentarily released.

Large, easy-to-open doors provide quick access to service items. Lube banks, filters, and checkpoints are grouped for added convenience.

Machine Information Center (MIC) captures and stores vital machine performance and utilization data to help improve uptime, productivity, and profit.

Conveniently located sight gauges let you check coolant and hydraulic fluid levels at a glance.



Keep daily operating costs low, profits high.

The less time you spend on daily maintenance chores, the more time you have to do productive work. That's why the 135D and 225D LC are loaded with features designed to simplify service and minimize downtime and expense. Service points are grouped conveniently behind large, easy-to-open service doors, so you can quickly perform daily checks and get on with your day.

Extended service intervals and remote-mounted fuel filters speed periodic maintenance. Plus a Machine Information Center and a state-of-the-art LCD color monitor help you make informed decisions about machine upkeep. And get back to the real work of increasing your bottom line.

1. Vertical spin-on fuel/water filters are positioned in the right rear compartment, simplifying service.
2. Using the easy-to-navigate LCD color monitor, you can easily keep tabs on up to 14 maintenance intervals and 32 machine operating parameters.
3. Centralized lube banks place difficult-to-lube zerks within easy reach, for faster greasing with less mess.
4. Fresh-air cab filter is quickly serviced at ground level where it's more likely to get done.
5. Large handrail, grab bars, self-cleaning steps, and anti-skid plates provide convenient same-side access to the engine-service area.
6. Oil cooler, radiator, and intercooler are arranged in parallel, so they're much easier to clean out than conventional in-line cooler designs.



Specifications

Engine 135D

Manufacturer and Model	Isuzu 4JJ1X
Non-Road Emission Standards	EPA Tier 3/EU Stage IIIA
Net Power (ISO9249)	93 hp (69 kW) @ 2,000 rpm
Cylinders	4
Displacement	183 cu. in. (3.0 L)
Aspiration	turbocharged, air-to-air charge air cooler
Off-Level Capacity	70% (35 deg.)

Cooling

Direct-drive, suction-type fan

Powertrain

Two-speed propel with automatic shift	
Travel Speed (maximum)	
Low	2.1 mph (3.3 km/h)
High	3.4 mph (5.5 km/h)

Hydraulics

Open center, load sensing; auxiliary hydraulic flow adjustable through monitor	
Main Pumps	2 variable-displacement pumps
Maximum Rated Flow	2 x 27.7 gpm (2 x 105 L/m)
Pilot Pump	one gear
Maximum Rated Flow	8.9 gpm (34 L/m)
Pressure Setting	570 psi (3930 kPa)
System Operating Pressure	
Implement Circuits	4,980 psi (34 336 kPa)
Travel Circuits	4,980 psi (34 336 kPa)
Swing Circuits	4,690 psi (32 336 kPa)
Controls	pilot levers, short stroke, low effort; hydraulic pilot controls with shutoff lever

Cylinders

Heat-treated, chrome-plated, polished cylinder rods, hardened steel (replaceable bushings) pivot pins			
	<i>Bore</i>	<i>Rod Diameter</i>	<i>Stroke</i>
Boom (2)	4.1 in. (105 mm)	2.8 in. (70 mm)	39.2 in. (995 mm)
Arm (1)	4.5 in. (115 mm)	3.1 in. (80 mm)	44.4 in. (1127 mm)
Bucket (1)	3.9 in. (100 mm)	2.8 in. (70 mm)	34.4 in. (875 mm)

Electrical

Batteries	2 x 12 volt
Reserve Capacity	180 min.
Alternator Rating	50 amp
Work Lights	halogen (2), one mounted on boom and one on frame

Undercarriage

Carrier Rollers (per side)	1
Track Rollers (per side)	7
Shoes (per side)	44
Drawbar Pull	26,303 lb. (11 931 kg)
Track	
Adjustment	hydraulic
Guides	front
Chain	sealed and lubricated

Swing Mechanism

135D

Swing Speed	13.7 rpm
Swing Torque	25,077 lb.-ft. (34 000 Nm)

Ground Pressure

24-in. (600 mm) Triple Semi-Grouser Shoes	5.80 psi (40 kPa)
28-in. (700 mm) Triple Semi-Grouser Shoes	4.93 psi (34 kPa)
20-in. (500 mm) Rubber Crawler Pads	6.96 psi (48 kPa)

Serviceability

Refill Capacities

Fuel Tank	58 gal. (220 L)
Cooling System	4 gal. (16 L)
Engine Oil with Filter	4 gal. (17 L)
Swing Drive	3.4 qt. (3.2 L)
Propel Gearbox (each)	4.4 qt. (4.2 L)

Operating Weights

With Full Fuel Tank; 175-lb. (79 kg) Operator;
30-in. (762 mm), 0.66-cu.-yd. (0.50 m³),
1,023-lb. (464 kg) Bucket; 9-ft. 11-in.
(3.01 m) Arm; and 8,113-lb. (3680 kg)

Counterweight	<i>Without Blade</i>	<i>With Blade</i>
24-in. (600 mm) Triple Semi-Grouser Shoes	30,737 lb. (13 942 kg)	32,337 lb. (14 668 kg)
28-in. (700 mm) Triple Semi-Grouser Shoes	31,147 lb. (14 128 kg)	32,747 lb. (14 854 kg)
20-in. (500 mm) Rubber Crawler Pads	30,314 lb. (13 750 kg)	31,914 lb. (14 476 kg)

Optional Components

Undercarriage

24-in. (600 mm) Triple Semi-Grouser Shoes	3,867 lb. (1754 kg)
28-in. (700 mm) Triple Semi-Grouser Shoes	4,277 lb. (1940 kg)
20-in. (500 mm) Rubber Crawler Pads	3,444 lb. (1562 kg)

One-Piece Boom (with arm cylinder) 2,050 lb. (930 kg)

Arm with Bucket Cylinder and Linkage

8 ft. 3 in. (2.52 m)	1,318 lb. (598 kg)
9 ft. 11 in. (3.01 m)	1,473 lb. (668 kg)

Boom Lift Cylinders (2) Total Weight 511 lb. (232 kg)

30-in. (762 mm), 0.66-cu.-yd. (0.50 m ³) General-Purpose Bucket	1,023 lb. (464 kg)
Counterweight (standard)	8,113 lb. (3680 kg)

Operating Dimensions

	<i>Arm Length 8 ft. 3 in. (2.52 m)</i>	<i>Arm Length 9 ft. 11 in. (3.01 m)</i>
Arm Force	14,490 lb. (64.5 kN)	12,942 lb. (57.6 kN)
Bucket Digging Force	21,698 lb. (96.5 kN)	21,698 lb. (96.5 kN)
Lifting Capacity Over Front at Ground Level		
20-ft. (6.1 m) Reach	6,020 lb. (2731 kg)	5,984 lb. (2714 kg)
A Maximum Reach	27 ft. 6 in. (8.38 m)	29 ft. (8.85 m)
A' Maximum Reach at Ground Level	27 ft. 1 in. (8.25 m)	28 ft. 7 in. (8.72 m)
B Maximum Digging Depth	18 ft. 2 in. (5.53 m)	19 ft. 9 in. (6.02 m)
B' Maximum Digging Depth at 8-ft. (2.44 m) Flat Bottom	17 ft. 5 in. (5.32 m)	19 ft. 2 in. (5.84 m)
C Maximum Cutting Height	30 ft. 4 in. (9.24 m)	31 ft. 7 in. (9.63 m)
D Maximum Dumping Height	22 ft. 3 in. (6.78 m)	23 ft. 7 in. (7.18 m)
E Minimum Swing Radius	6 ft. 11 in. (2.10 m)	8 ft. (2.44 m)
F Maximum Vertical Wall	16 ft. 5 in. (5.01 m)	16 ft. 6 in. (5.02 m)
G Tail Swing Radius	4 ft. 10 in. (1.48 m)	4 ft. 10 in. (1.48 m)

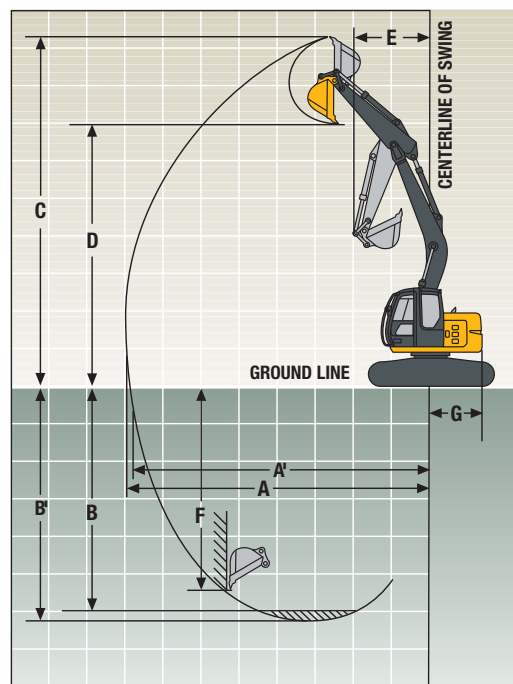

Machine Dimensions

135D

	<i>Arm Length</i>	<i>Arm Length</i>
	8 ft. 3 in. (2.52 m)	9 ft. 11 in. (3.01 m)
A Overall Length	24 ft. 2 in. (7.37 m)	24 ft. 3 in. (7.38 m)
B Overall Height	9 ft. 1 in. (2.78 m)	9 ft. 1 in. (2.78 m)
C Overall Width:		
24-in. (600 mm) Triple Semi-Grouser		
Shoes	8 ft. 6 in. (2.59 m)	
28-in. (700 mm) Triple Semi-Grouser		
Shoes	8 ft. 10 in. (2.69 m)	
20-in. (500 mm) Rubber Crawler Pads	8 ft. 2 in. (2.49 m)	
D Rear-End Length/Swing Radius	4 ft. 10 in. (1.48 m)	
E Distance Between Idler/Sprocket Centerline	9 ft. 5 in. (2.88 m)	
F Undercarriage Length	11 ft. 9 in. (3.58 m)	
G Counterweight Clearance	2 ft. 10 in. (0.87 m)	
H Cab Height	9 ft. (2.74 m)	
I Ground Clearance	17 in. (430 mm)	
J Upperstructure Width	8 ft. 2 in. (2.48 m)	
K Gauge Width	6 ft. 6 in. (1.99 m)	
L Blade Lift Height	23 in. (590 mm)	
M Blade Cut Below Grade	20 in. (520 mm)	
N Blade Lift Angle	17 deg.	
Blade Height	19 in. (480 mm)	
Blade Width:		
24 in. (600 mm) Triple Semi-Grouser		
Shoes	8 ft. 2 in. (2.49 m)	
28-in. (700 mm) Triple Semi-Grouser		
Shoes	8 ft. 10 in. (2.69 m)	
20-in. (500 mm) Rubber Crawler Pads	8 ft. 2 in. (2.49 m)	

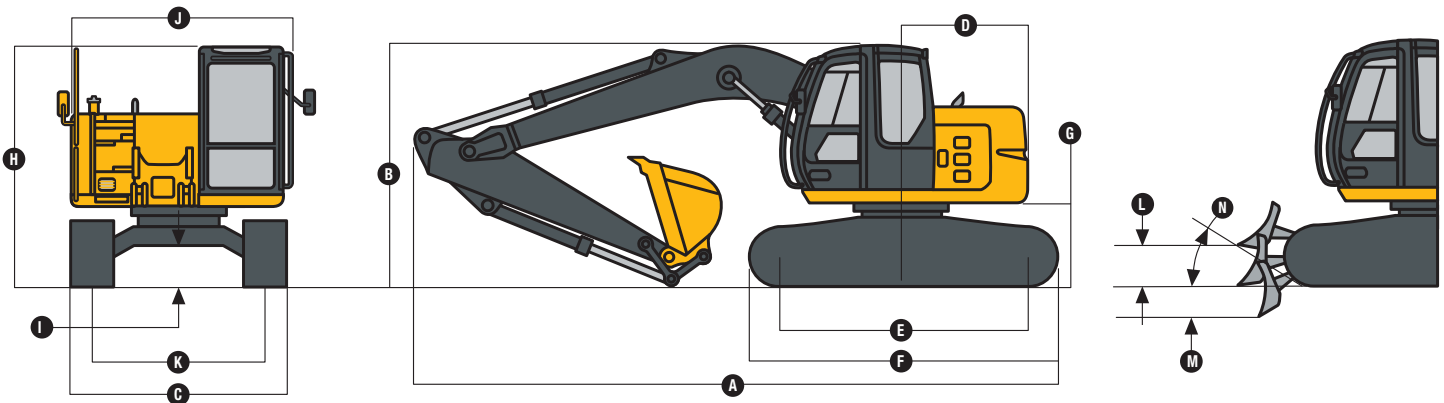

Lift Capacities

Boldface italic type indicates hydraulic-limited capacities; lightface type indicates stability-limited capacities, in lb. (kg). Ratings at bucket lift hook; machine equipped with 0.37-cu.-yd. (0.28 m³) bucket, 15-ft. 1-in. (4.6 m) boom, and standard gauge, and situated on firm, uniform surface. Total load includes weight of cables, hook, etc. Figures do not exceed 87% of hydraulic capacities or 75% of weight needed to tip machine. All capacities are based on SAE J1097.

Load Point Height	5 ft. (1.52 m)		10 ft. (3.05 m)		15 ft. (4.57 m)		20 ft. (6.10 m)		25 ft. (7.62 m)	
	Over Front	Over Side	Over Front	Over Side	Over Front	Over Side	Over Front	Over Side	Over Front	Over Side
<i>With 8-ft. 3-in. (2.52 m) arm and 24-in. (600 mm) shoes, without blade</i>										
20 ft. (6.10 m)					6,263 (2841)	6,263 (2841)				
15 ft. (4.57 m)					6,368 (2888)	6,368 (2888)	6,073 (2755)	4,749 (2154)		
10 ft. (3.05 m)			9,119 (4136)	9,119 (4136)	7,951 (3607)	7,508 (3406)	6,413 (2909)	4,612 (2092)		
5 ft. (1.52 m)					9,875 (4479)	6,924 (3141)	6,158 (2793)	4,375 (1984)		
Ground Line					9,365 (4248)	6,468 (2934)	5,925 (2688)	4,159 (1886)		
-5 ft. (-1.52 m)	6,904 (3132)	6,904 (3132)	16,795 (7618)	11,997 (5442)	9,159 (4154)	6,283 (2850)	5,805 (2633)	4,049 (1837)		
-10 ft. (-3.05 m)			14,858 (6739)	12,190 (5529)	9,204 (4175)	6,324 (2869)	5,870 (2663)	4,109 (1864)		
-15 ft. (-4.57 m)					5,738 (2603)	5,738 (2603)				

Lift Capacities (continued)

135D

Boldface italic type indicates hydraulic-limited capacities; lightface type indicates stability-limited capacities, in lb. (kg). Ratings at bucket lift hook; machine equipped with 0.37-cu.-yd. (0.28 m³) bucket, 15-ft. 1-in. (4.6 m) boom, and standard gauge, and situated on firm, uniform surface. Total load includes weight of cables, hook, etc. Figures do not exceed 87% of hydraulic capacities or 75% of weight needed to tip machine. All capacities are based on SAE J1097.

Load Point Height	5 ft. (1.52 m)		10 ft. (3.05 m)		15 ft. (4.57 m)		20 ft. (6.10 m)		25 ft. (7.62 m)	
	Over Front	Over Side	Over Front	Over Side	Over Front	Over Side	Over Front	Over Side	Over Front	Over Side
<i>With 9-ft. 11-in. (3.01 m) arm and 24-in. (600 mm) shoes, without blade</i>										
20 ft. (6.10 m)					5,129 (2326)	5,129 (2326)	3,764 (1707)	3,764 (1707)		
15 ft. (4.57 m)					5,342 (2423)	5,342 (2423)	5,603 (2541)	4,812 (2183)		
10 ft. (3.05 m)			5,477 (2484)	5,477 (2484)	6,709 (3043)	6,709 (3043)	6,215 (2819)	4,644 (2106)	4,011 (1819)	3,010 (1365)
5 ft. (1.52 m)					9,350 (4241)	7,013 (3181)	6,168 (2798)	4,376 (1985)	4,176 (1894)	2,914 (1322)
Ground Line			10,793 (4896)	10,793 (4896)	9,374 (4252)	6,463 (2932)	5,889 (2671)	4,117 (1867)	4,061 (1842)	2,805 (1272)
-5 ft. (-1.52 m)	6,419 (2912)	6,419 (2912)	15,472 (7018)	11,797 (5351)	9,067 (4113)	6,188 (2807)	5,718 (2594)	3,958 (1795)		
-10 ft. (-3.05 m)	14,078 (6386)	14,078 (6386)	16,229 (7361)	11,909 (5402)	9,036 (4099)	6,160 (2794)	5,707 (2589)	3,949 (1791)		
-15 ft. (-4.57 m)			11,461 (5199)	11,461 (5199)	7,798 (3537)	6,377 (2893)				

With 8-ft. 3-in. (2.52 m) arm and 24-in. (600 mm) shoes, with 8-ft. 2-in. (2.49 m) blade

20 ft. (6.10 m)					6,263 (2841)	6,263 (2841)				
15 ft. (4.57 m)					6,368 (2888)	6,368 (2888)	6,073 (2755)	5,183 (2351)		
10 ft. (3.05 m)			9,119 (4136)	9,119 (4136)	7,951 (3607)	7,951 (3607)	6,859 (3111)	5,047 (2289)		
5 ft. (1.52 m)					10,242 (4646)	7,548 (3424)	7,760 (3520)	4,810 (2182)		
Ground Line					11,825 (5364)	7,092 (3217)	8,477 (3845)	4,594 (2084)		
-5 ft. (-1.52 m)	6,904 (3132)	6,904 (3132)	16,795 (7618)	13,101 (5943)	11,921 (5407)	6,907 (3133)	8,471 (3842)	4,484 (2034)		
-10 ft. (-3.05 m)			14,858 (6739)	13,294 (6030)	10,399 (4717)	6,947 (3151)	6,917 (3137)	4,544 (2061)		
-15 ft. (-4.57 m)					5,738 (2603)	5,738 (2603)				

With 9-ft. 11-in. (3.01 m) arm and 24-in. (600 mm) shoes, with 8-ft. 2-in. (2.49 m) blade on ground

20 ft. (6.10 m)					5,129 (2326)	5,129 (2326)	3,764 (1707)	3,764 (1707)		
15 ft. (4.57 m)					5,342 (2423)	5,342 (2423)	5,603 (2541)	5,247 (2380)		
10 ft. (3.05 m)			5,477 (2484)	5,477 (2484)	6,709 (3043)	6,709 (3043)	6,215 (2819)	5,079 (2304)	4,011 (1819)	3,344 (1517)
5 ft. (1.52 m)					9,350 (4241)	7,636 (3464)	7,236 (3282)	4,810 (2182)	5,504 (2497)	3,247 (1473)
Ground Line			10,793 (4896)	10,793 (4896)	11,321 (5135)	7,087 (3215)	8,149 (3696)	4,552 (2065)	5,967 (2707)	3,138 (1423)
-5 ft. (-1.52 m)	6,419 (2912)	6,419 (2912)	15,472 (7018)	12,900 (5851)	11,909 (5402)	6,812 (3090)	8,453 (3834)	4,393 (1993)		
-10 ft. (-3.05 m)	14,078 (6386)	14,078 (6386)	16,229 (7361)	13,013 (5903)	10,957 (4970)	6,784 (3077)	7,628 (3460)	4,383 (1988)		
-15 ft. (-4.57 m)			11,461 (5199)	11,461 (5199)	7,798 (3537)	7,001 (3176)				

With 8-ft. 3-in. (2.52 m) arm and 28-in. (700 mm) shoes, without blade

20 ft. (6.10 m)					6,263 (2841)	6,263 (2841)				
15 ft. (4.57 m)					6,368 (2888)	6,368 (2888)	6,073 (2755)	4,827 (2189)		
10 ft. (3.05 m)			9,119 (4136)	9,119 (4136)	7,951 (3607)	7,621 (3457)	6,508 (2952)	4,691 (2128)		
5 ft. (1.52 m)					10,016 (4543)	7,037 (3192)	6,253 (2836)	4,454 (2020)		
Ground Line					9,506 (4312)	6,581 (2985)	6,020 (2731)	4,238 (1922)		
-5 ft. (-1.52 m)	6,904 (3132)	6,904 (3132)	16,795 (7618)	12,197 (5532)	9,300 (4218)	6,396 (2901)	5,900 (2676)	4,128 (1872)		
-10 ft. (-3.05 m)			14,858 (6739)	12,390 (5620)	9,345 (4239)	6,437 (2920)	5,965 (2706)	4,188 (1900)		
-15 ft. (-4.57 m)					5,738 (2603)	5,738 (2603)				

With 9-ft. 11-in. (3.01 m) arm and 28-in. (700 mm) shoes, without blade

20 ft. (6.10 m)					5,129 (2326)	5,129 (2326)	3,764 (1707)	3,764 (1707)		
15 ft. (4.57 m)					5,342 (2423)	5,342 (2423)	5,603 (2541)	4,891 (2219)		
10 ft. (3.05 m)			5,477 (2484)	5,477 (2484)	6,709 (3043)	6,709 (3043)	6,215 (2819)	4,723 (2142)	4,011 (1819)	3,071 (1393)
5 ft. (1.52 m)					9,350 (4241)	7,126 (3232)	6,263 (2841)	4,454 (2020)	4,248 (1927)	2,974 (1349)
Ground Line			10,793 (4896)	10,793 (4896)	9,515 (4316)	6,576 (2983)	5,984 (2714)	4,196 (1903)	4,132 (1874)	2,865 (1300)
-5 ft. (-1.52 m)	6,419 (2912)	6,419 (2912)	15,472 (7018)	11,997 (5442)	9,208 (4177)	6,301 (2858)	5,812 (2636)	4,037 (1831)		
-10 ft. (-3.05 m)	14,078 (6386)	14,078 (6386)	16,229 (7361)	12,109 (5493)	9,177 (4163)	6,273 (2845)	5,802 (2632)	4,027 (1827)		
-15 ft. (-4.57 m)			11,461 (5199)	11,461 (5199)	7,798 (3537)	6,490 (2944)				

With 8-ft. 3-in. (2.52 m) arm and 28-in. (700 mm) shoes, with 8-ft. 10-in. (2.69 m) blade

20 ft. (6.10 m)					6,263 (2841)	6,263 (2841)				
15 ft. (4.57 m)					6,368 (2888)	6,368 (2888)	6,073 (2755)	5,262 (2387)		
10 ft. (3.05 m)			9,119 (4136)	9,119 (4136)	7,951 (3607)	7,951 (3607)	6,859 (3111)	5,125 (2325)		
5 ft. (1.52 m)					10,242 (4646)	7,661 (3475)	7,760 (3520)	4,889 (2218)		
Ground Line					11,825 (5364)	7,205 (3268)	8,477 (3845)	4,673 (2120)		
-5 ft. (-1.52 m)	6,904 (3132)	6,904 (3132)	16,795 (7618)	13,301 (6033)	11,921 (5407)	7,020 (3184)	8,471 (3842)	4,562 (2069)		
-10 ft. (-3.05 m)			14,858 (6739)	13,494 (6121)	10,399 (4717)	7,061 (3203)	6,917 (3137)	4,623 (2097)		
-15 ft. (-4.57 m)					5,738 (2603)	5,738 (2603)				

Lift Capacities (continued)

135D

Boldface italic type indicates hydraulic-limited capacities; lightface type indicates stability-limited capacities, in lb. (kg). Ratings at bucket lift hook; machine equipped with 0.37-cu.-yd. (0.28 m³) bucket, 15-ft. 1-in. (4.6 m) boom, and standard gauge, and situated on firm, uniform surface. Total load includes weight of cables, hook, etc. Figures do not exceed 87% of hydraulic capacities or 75% of weight needed to tip machine. All capacities are based on SAE J1097.

Load Point Height	5 ft. (1.52 m)		10 ft. (3.05 m)		15 ft. (4.57 m)		20 ft. (6.10 m)		25 ft. (7.62 m)	
	Over Front	Over Side	Over Front	Over Side	Over Front	Over Side	Over Front	Over Side	Over Front	Over Side
<i>With 9-ft. 11-in. (3.01 m) arm and 28-in. (700 mm) shoes, with 8-ft. 10-in. (2.69 m) blade on ground</i>										
20 ft. (6.10 m)					5,129 (2326)	5,129 (2326)	3,764 (1707)	3,764 (1707)		
15 ft. (4.57 m)					5,342 (2423)	5,342 (2423)	5,603 (2541)	5,326 (2416)		
10 ft. (3.05 m)			5,477 (2484)	5,477 (2484)	6,709 (3043)	6,709 (3043)	6,215 (2819)	5,158 (2340)	4,011 (1819)	3,405 (1544)
5 ft. (1.52 m)					9,350 (4241)	7,750 (3515)	7,236 (3282)	4,889 (2218)	5,504 (2497)	3,308 (1500)
Ground Line			10,793 (4896)	10,793 (4896)	11,321 (5135)	7,200 (3266)	8,149 (3696)	4,631 (2101)	5,967 (2707)	3,199 (1451)
-5 ft. (-1.52 m)	6,419 (2912)	6,419 (2912)	15,472 (7018)	13,100 (5942)	11,909 (5402)	6,925 (3141)	8,453 (3834)	4,472 (2028)		
-10 ft. (-3.05 m)	14,078 (6386)	14,078 (6386)	16,229 (7361)	13,213 (5993)	10,957 (4970)	6,897 (3128)	7,628 (3460)	4,462 (2024)		
-15 ft. (-4.57 m)			11,461 (5199)	11,461 (5199)	7,798 (3537)	7,114 (3227)				

With 8-ft. 3-in. (2.52 m) arm and 20-in. (500 mm) rubber crawler pads, without blade

20 ft. (6.10 m)					6,263 (2841)	6,263 (2841)				
15 ft. (4.57 m)					6,368 (2888)	6,368 (2888)	6,073 (2755)	4,627 (2099)		
10 ft. (3.05 m)			9,119 (4136)	9,119 (4136)	7,951 (3607)	7,333 (3326)	6,254 (2837)	4,490 (2037)		
5 ft. (1.52 m)					9,637 (4371)	6,749 (3061)	5,999 (2721)	4,254 (1930)		
Ground Line					9,128 (4140)	6,293 (2854)	5,766 (2615)	4,038 (1832)		
-5 ft. (-1.52 m)	6,904 (3132)	6,904 (3132)	16,795 (7618)	11,688 (5302)	8,921 (4046)	6,109 (2771)	5,647 (2561)	3,927 (1781)		
-10 ft. (-3.05 m)			14,858 (6739)	11,881 (5389)	8,966 (4067)	6,149 (2789)	5,712 (2591)	3,987 (1808)		
-15 ft. (-4.57 m)					5,738 (2603)	5,738 (2603)				

With 9-ft. 11-in. (3.01 m) arm and 20-in. (500 mm) rubber crawler pads, without blade

20 ft. (6.10 m)					5,129 (2326)	5,129 (2326)	3,764 (1707)	3,764 (1707)		
15 ft. (4.57 m)					5,342 (2423)	5,342 (2423)	5,603 (2541)	4,691 (2128)		
10 ft. (3.05 m)			5,477 (2484)	5,477 (2484)	6,709 (3043)	6,709 (3043)	6,215 (2819)	4,522 (2051)	4,011 (1819)	2,917 (1323)
5 ft. (1.52 m)					9,350 (4241)	6,838 (3102)	6,009 (2726)	4,254 (1930)	4,058 (1841)	2,820 (1279)
Ground Line			10,793 (4896)	10,793 (4896)	9,137 (4144)	6,288 (2852)	5,731 (2600)	3,995 (1812)	3,942 (1788)	2,711 (1230)
-5 ft. (-1.52 m)	6,419 (2912)	6,419 (2912)	15,472 (7018)	11,488 (5211)	8,829 (4005)	6,013 (2727)	5,559 (2522)	3,837 (1740)		
-10 ft. (-3.05 m)	14,078 (6386)	14,078 (6386)	16,229 (7361)	11,601 (5262)	8,798 (3991)	5,985 (2715)	5,549 (2517)	3,827 (1736)		
-15 ft. (-4.57 m)			11,461 (5199)	11,461 (5199)	7,798 (3537)	6,203 (2814)				

With 8-ft. 3-in. (2.52 m) arm and 20-in. (500 mm) rubber crawler pads, with 8-ft. 2-in. (2.49 m) blade

20 ft. (6.10 m)					6,263 (2841)	6,263 (2841)				
15 ft. (4.57 m)					6,368 (2888)	6,368 (2888)	6,073 (2755)	5,061 (2296)		
10 ft. (3.05 m)			9,119 (4136)	9,119 (4136)	7,951 (3607)	7,951 (3607)	6,859 (3111)	4,925 (2234)		
5 ft. (1.52 m)					10,242 (4646)	7,372 (3344)	7,760 (3520)	4,688 (2126)		
Ground Line					11,825 (5364)	6,917 (3137)	8,477 (3845)	4,472 (2028)		
-5 ft. (-1.52 m)	6,904 (3132)	6,904 (3132)	16,795 (7618)	12,791 (5802)	11,921 (5407)	6,732 (3054)	8,471 (3842)	4,362 (1979)		
-10 ft. (-3.05 m)			14,858 (6739)	12,984 (5889)	10,399 (4717)	6,772 (3072)	6,917 (3137)	4,422 (2006)		
-15 ft. (-4.57 m)					5,738 (2603)	5,738 (2603)				

With 9-ft. 11-in. (3.01 m) arm and 20-in. (500 mm) rubber crawler pads, with 8-ft. 2-in. (2.49 m) blade on ground

20 ft. (6.10 m)					5,129 (2326)	5,129 (2326)	3,764 (1707)	3,764 (1707)		
15 ft. (4.57 m)					5,342 (2423)	5,342 (2423)	5,603 (2541)	5,125 (2325)		
10 ft. (3.05 m)			5,477 (2484)	5,477 (2484)	6,709 (3043)	6,709 (3043)	6,215 (2819)	4,957 (2248)	4,011 (1819)	3,250 (1474)
5 ft. (1.52 m)					9,350 (4241)	7,461 (3384)	7,236 (3282)	4,688 (2126)	5,504 (2497)	3,154 (1431)
Ground Line			10,793 (4896)	10,793 (4896)	11,321 (5135)	6,912 (3135)	8,149 (3696)	4,430 (2009)	5,967 (2707)	3,045 (1381)
-5 ft. (-1.52 m)	6,419 (2912)	6,419 (2912)	15,472 (7018)	12,591 (5711)	11,909 (5402)	6,636 (3010)	8,453 (3834)	4,271 (1937)		
-10 ft. (-3.05 m)	14,078 (6386)	14,078 (6386)	16,229 (7361)	12,703 (5762)	10,957 (4970)	6,609 (2998)	7,628 (3460)	4,261 (1933)		
-15 ft. (-4.57 m)			11,461 (5199)	11,461 (5199)	7,798 (3537)	6,826 (3096)				

Buckets

135D

A full line of buckets is offered to meet a wide variety of applications. The buckets have an adjustable bushing for side clearance, with the exception of the ditching bucket. Tooth selection includes either the John Deere Fanggs®, Standard, Tiger, Twin Tiger, Abrasion panel, or Flare tooth, or the ESCO (Vertalok) Standard, Tiger, Twin Tiger, or Flare tooth. Replaceable cutting edges are available through John Deere parts. Optional side cutters add 6 inches (150 mm) to bucket widths. Capacities are SAE heaped ratings.

Type Bucket	Bucket Width		Bucket Capacity*		Weight		Bucket Dig Force		Arm Dig Force 8 ft. 3 in. (2.52 m)		Arm Dig Force 9 ft. 11 in. (3.01 m)		Bucket Tip Radius		No. Teeth
	in.	mm	cu. yd.	m ³	lb.	kg	lb.	kN	lb.	kN	lb.	kN	in.	mm	
General-Purpose Plate Lip	24	610	0.50	0.38	899	408	20,751	92.3	14,310	63.7	12,823	57.0	52.27	1328	4
	30	762	0.66	0.50	1,030	468	20,751	92.3	14,310	63.7	12,823	57.0	52.27	1328	4
	36	914	0.83	0.63	1,173	533	20,751	92.3	14,310	63.7	12,823	57.0	52.27	1328	5
	42	1065	1.01	0.77	1,304	592	20,751	92.3	14,310	63.7	12,823	57.0	52.27	1328	5
Heavy-Duty Plate Lip	24	610	0.48	0.37	1,014	460	20,751	92.3	14,310	63.7	12,823	57.0	52.27	1328	4
	30	760	0.65	0.50	1,150	522	20,751	92.3	14,310	63.7	12,823	57.0	52.27	1328	4
	36	915	0.81	0.62	1,297	589	20,751	92.3	14,310	63.7	12,823	57.0	52.27	1328	5
	42	1067	0.99	0.76	1,390	631	20,751	92.3	14,310	63.7	12,823	57.0	52.27	1328	5
Ditching	60	1500	0.83	0.63	1,007	457	20,751	92.3	16,002	71.2	14,149	62.9	36.25	921	0

*All capacities are SAE heaped ratings and with side cutters.

Bucket Selection Guide*

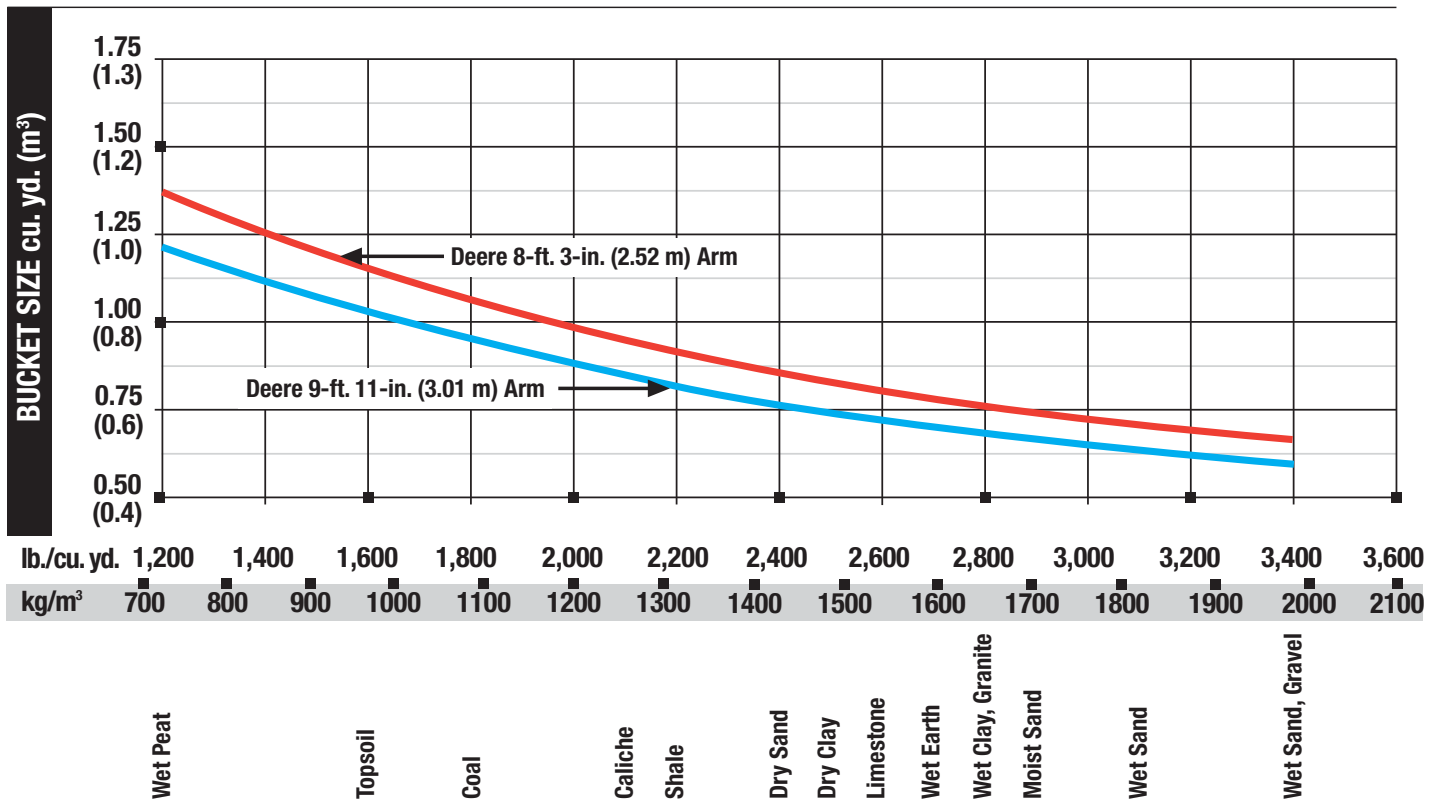

*Contact your John Deere dealer for optimum bucket and attachment selections. These recommendations are for general conditions and average use. Does not include optional equipment such as thumbs or couplers. Larger buckets may be possible when using light materials, for flat and level operations, less compacted materials, and volume loading applications such as mass excavation applications in ideal conditions. Smaller buckets are recommended for adverse conditions such as off-level applications, rocks, and uneven surfaces. Bucket capacity indicated is SAE heaped.

Specifications

225D
LC

Engine	225D LC
Manufacturer and Model	Isuzu AI-4HK1XYSA-02
Non-Road Emission Standards	EPA Tier 3/EU Stage IIIA
Net Power (ISO9249)	159 hp (118 kW) @ 2,000 rpm
Cylinders	4
Displacement	325 cu. in. (5.2 L)
Aspiration	turbocharged, intercooled
Off-Level Capacity	70% (35 deg.)

Cooling
Direct-drive, suction-type fan

Powertrain	
Two-speed propel with automatic shift	
Travel Speed (maximum)	
Low	2.2 mph (3.5 km/h)
High	3.4 mph (5.5 km/h)

Hydraulics	
Open center, load sensing; auxiliary hydraulic flow adjustable through monitor	
Main Pumps	2 variable-displacement axial-piston pumps
Maximum Rated Flow	2 x 56.0 gpm (2 x 212 L/min.)
Pilot Pump	one gear
Maximum Rated Flow	7.9 gpm (30 L/min.)
Pressure Setting	570 psi (3930 kPa)
System Operating Pressure	
Implement Circuits	4,980 psi (34 336 kPa)
Travel Circuits	4,980 psi (34 336 kPa)
Swing Circuits	4,410 psi (30 406 kPa)
Controls	pilot levers, short stroke, low effort; hydraulic pilot controls with shutoff lever

Cylinders			
Heat-treated, chrome-plated, polished cylinder rods; hardened-steel (replaceable bushings) pivot pins			
	<i>Bore</i>	<i>Rod Diameter</i>	<i>Stroke</i>
Boom (2)	4.72 in. (120 mm)	3.35 in. (85 mm)	49.61 in. (1260 mm)
Arm (1)	5.31 in. (135 mm)	3.74 in. (95 mm)	58.10 in. (1475 mm)
Bucket (1)	4.53 in. (115 mm)	3.15 in. (80 mm)	41.73 in. (1060 mm)

Electrical	
Batteries	2 x 12 volt
Reserve Capacity	180 min.
Alternator	50 amp
Lights	halogen (one mounted on boom, one mounted on frame)

Undercarriage	
Planetary final drives with axial piston motors	
Carrier Rollers (per side)	2
Track Rollers (per side)	8
Shoes (per side)	49
Drawbar Pull	45,636 lb. (20 719 kg)
Track	
Adjustment	hydraulic
Guides	front and center
Chain	sealed and lubricated

Swing Mechanism

225D LC

Swing Speed	13.3 rpm
Swing Torque	50,662 lb.-ft. (68 900 Nm)

Ground Pressure

Triple Semi-Grouser Shoes	
28 in. (700 mm)	6.24 psi (43.0 kPa)
32 in. (800 mm)	5.51 psi (38.0 kPa)

Serviceability

Refill Capacities

Fuel Tank	85 gal. (320.0 L)
Cooling System	28 qt. (26.0 L)
Engine Oil with Filter	24.3 qt. (23.0 L)
Hydraulic Tank	33 gal. (123.0 L)
Hydraulic System	60.8 gal. (230.0 L)
Gearbox	
Propel (each)	7.2 qt. (6.8 L)
Swing	7.3 qt. (6.9 L)
Pump Drive	1.1 qt. (1.0 L)

Operating Weights

With Full Fuel Tank; 175-lb. (79 kg) Operator; 42-in. (1067 mm), 1.09-cu.-yd. (0.83 m³), 1,731-lb. (721 kg) Heavy-Duty Bucket; 9-ft. 7-in. (2.91 m) Arm; 16,710-lb. (7586 kg) Counterweight; and 32-in. (800 mm) Triple Semi-Grouser Shoes

53,936 lb. (24 487 kg)

Optional Components

Undercarriage with Triple Semi-Grouser Shoes	
28 in. (700 mm)	17,155 lb. (7788 kg)
32 in. (800 mm)	17,805 lb. (8083 kg)
Upperstructure with Full Fuel Tank (less front attachments and counterweight)	
	10,845 lb. (4924 kg)
One-Piece Boom (with arm cylinder)	3,890 lb. (1766 kg)
Arm with Bucket Cylinder and Linkage	
7 ft. 11 in. (2.42 m)	2,045 lb. (928 kg)
9 ft. 7 in. (2.91 m)	2,180 lb. (990 kg)
Boom Lift Cylinders (2) Total Weight	
	749 lb. (340 kg)
42-in. (1067 mm), 1.09-cu.-yd. (0.83 m ³)	
Heavy-Duty Bucket	1,590 lb. (722 kg)
Counterweight (standard)	16,710 lb. (7586 kg)

Operating Dimensions

	Arm Length 7 ft. 11 in. (2.42 m)	Arm Length 9 ft. 7 in. (2.91 m)
Arm Force	27,877 lb. (124.0 kN)	22,924 lb. (102.0 kN)
Bucket Digging Force	29,099 lb. (129.4 kN)	29,099 lb. (129.4 kN)
Lifting Capacity Over Front at Ground Level		
20-ft. (6.1 m) Reach with Power Boost	14,533 lb. (6598 kg)	14,248 lb. (6469 kg)
A Maximum Reach	31 ft. 3 in. (9.52 m)	32 ft. 10 in. (10.01 m)
A' Maximum Reach at Ground Level	30 ft. 7 in. (9.32 m)	32 ft. 3 in. (9.83 m)
B Maximum Digging Depth	20 ft. 5 in. (6.21 m)	22 ft. 0 in. (6.70 m)
B' Maximum Digging Depth at 8-ft. (2.44 m) Flat Bottom	19 ft. 7 in. (5.96 m)	21 ft. 4 in. (6.50 m)
C Maximum Cutting Height	34 ft. 8 in. (10.56 m)	36 ft. 0 in. (10.98 m)
D Maximum Dumping Height	25 ft. 1 in. (7.64 m)	26 ft. 5 in. (8.05 m)
E Minimum Swing Radius	9 ft. 0 in. (2.74 m)	7 ft. 9 in. (2.37 m)
F Maximum Vertical Wall	17 ft. 2 in. (5.23 m)	19 ft. 5 in. (5.92 m)
G Tail Swing Radius	5 ft. 6 in. (1.68 m)	5 ft. 6 in. (1.68 m)

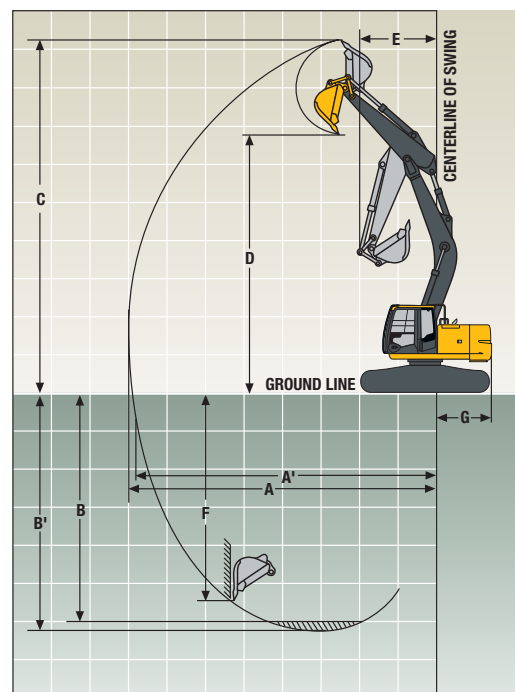

Machine Dimensions

225D LC

	<i>Arm Length</i>	<i>Arm Length</i>
	7 ft. 11 in. (2.42 m)	9 ft. 7 in. (2.91 m)
A Overall Length	32 ft. 0 in. (9.74 m)	31 ft. 7 in. (9.62 m)
B Overall Height	10 ft. 6 in. (3.20 m)	9 ft. 10 in. (2.98 m)
C Overall Width with Triple Semi-Grouser		
Shoes:		
28 in. (700 mm)	10 ft. 2 in. (3.10 m)	
32 in. (800 mm)	10 ft. 6 in. (3.20 m)	
D Rear-End Length/Swing Radius	5 ft. 6 in. (1.68 m)	
E Distance Between Idler/Sprocket Centerline ..	12 ft. 0 in. (3.66 m)	
F Undercarriage Length	14 ft. 8 in. (4.46 m)	
G Counterweight Clearance	3 ft. 2 in. (975 mm)	
H Cab Height	9 ft. 8 in. (2.95 m)	
I Ground Clearance	18 in. (450 mm)	
J Upperstructure Width	9 ft. 5 in. (2.87 m)	
K Gauge Width	7 ft. 10 in. (2.39 m)	

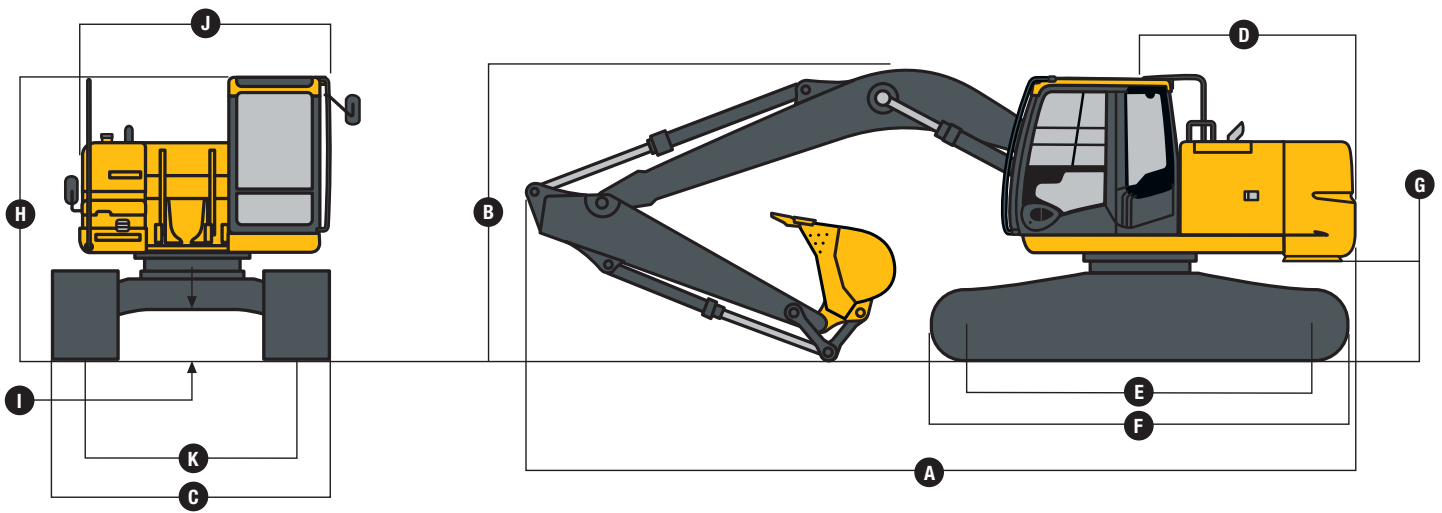

Lift Charts

225D LC

Boldface italic type indicates hydraulic-limited capacities; lightface type indicates stability-limited capacities, in lb. (kg). Ratings are at bucket lift hook, using 1.05-cu.-yd. (0.80 m³), 1,455-lb. (660 kg) bucket; standard counterweight, situated on firm, level, uniform supporting surface. Figures do not exceed 87 percent of hydraulic capacity or 75 percent of weight needed to tip machine.

Load Point Height	5 ft. (1.52 m)		10 ft. (3.05 m)		15 ft. (4.57 m)		20 ft. (6.10 m)		25 ft. (7.62 m)	
	Over Front	Over Side	Over Front	Over Side	Over Front	Over Side	Over Front	Over Side	Over Front	Over Side
<i>With 7-ft. 11-in. (2.42 m) arm and 28-in. (700 mm) triple semi-grouser shoes</i>										
25 ft. (7.62 m)					7,000 (3175)	7,000 (3175)				
20 ft. (6.10 m)					10,121 (4591)	10,121 (4591)	9,968 (4521)	9,968 (4521)		
15 ft. (4.57 m)					12,700 (5761)	12,700 (5761)	10,914 (4951)	10,476 (4752)	10,156 (4607)	7,107 (3224)
10 ft. (3.05 m)					17,268 (7833)	15,432 (7000)	12,772 (5793)	9,921 (4500)	10,816 (4906)	6,891 (3126)
5 ft. (1.52 m)							14,685 (6661)	9,356 (4244)	11,175 (5069)	6,624 (3005)
Ground Line					22,240 (10 088)	13,764 (6243)	15,465 (7015)	8,984 (4075)	10,952 (4968)	6,420 (2912)
-5 ft. (-1.52 m)					21,260 (9643)	13,739 (6232)	15,316 (6947)	8,851 (4015)	10,879 (4935)	6,353 (2882)
-10 ft. (-3.05 m)			19,713 (8942)	19,713 (8942)	18,806 (8530)	13,935 (6231)	14,164 (6425)	8,945 (4057)		
-15 ft. (-4.57 m)			17,364 (7876)	17,364 (7876)	13,923 (6315)	13,923 (6315)				

<i>With 9-ft. 7-in. (2.91 m) arm and 28-in. (700 mm) triple semi-grouser shoes</i>										
25 ft. (7.62 m)							6,348 (2879)	6,348 (2879)		
20 ft. (6.10 m)							8,868 (4022)	8,868 (4022)	6,672 (3026)	6,672 (3026)
15 ft. (4.57 m)					11,093 (5032)	11,093 (5032)	9,940 (4509)	9,940 (4509)	9,351 (4242)	7,198 (3265)
10 ft. (3.05 m)					15,571 (7063)	15,571 (7063)	11,900 (5298)	10,065 (4565)	10,194 (4624)	6,947 (3151)
5 ft. (1.52 m)					20,080 (9108)	14,511 (6582)	14,025 (6362)	9,458 (4290)	11,209 (5084)	6,648 (3015)
Ground Line					22,077 (10 014)	13,831 (6274)	15,484 (7023)	9,014 (4089)	10,940 (4962)	6,402 (2904)
-5 ft. (-1.52 m)			14,178 (6431)	14,178 (6431)	21,813 (9894)	13,668 (6200)	15,276 (6929)	8,807 (3995)	10,804 (4901)	6,278 (2848)
-10 ft. (-3.05 m)	18,661 (8464)	18,661 (8464)	23,452 (10 638)	23,452 (10 638)	19,922 (9036)	13,782 (6251)	14,804 (6715)	8,824 (4003)	10,860 (4926)	6,339 (2875)
-15 ft. (-4.57 m)			20,995 (9523)	20,995 (9523)	15,959 (7239)	14,152 (6419)	11,521 (5226)	9,112 (4133)		

<i>With 7-ft. 11-in. (2.42 m) arm and 32-in. (800 mm) triple semi-grouser shoes</i>										
25 ft. (7.62 m)					7,000 (3175)	7,000 (3175)				
20 ft. (6.10 m)					10,121 (4591)	10,121 (4591)	9,968 (4521)	9,968 (4521)		
15 ft. (4.57 m)					12,700 (5761)	12,700 (5761)	10,914 (4951)	10,604 (4810)	10,156 (4607)	7,204 (3268)
10 ft. (3.05 m)					17,268 (7833)	15,619 (7085)	12,772 (5793)	10,049 (4558)	10,816 (4906)	6,988 (3170)
5 ft. (1.52 m)							14,685 (6661)	9,484 (4302)	11,332 (5140)	6,721 (3049)
Ground Line					22,240 (10 088)	13,951 (6328)	15,678 (7111)	9,112 (4133)	11,109 (5039)	6,517 (2956)
-5 ft. (-1.52 m)					21,260 (9643)	13,926 (6317)	15,529 (7044)	8,979 (4073)	11,036 (5006)	6,450 (2926)
-10 ft. (-3.05 m)			19,713 (8942)	19,713 (8942)	18,806 (8530)	14,122 (6406)	14,164 (6425)	9,073 (4115)		
-15 ft. (-4.57 m)			17,364 (7876)	17,364 (7876)	13,923 (6315)	13,923 (6315)				

<i>With 9-ft. 7-in. (2.91 m) arm and 32-in. (800 mm) triple semi-grouser shoes</i>										
25 ft. (7.62 m)							6,348 (2879)	6,348 (2879)		
20 ft. (6.10 m)							8,868 (4022)	8,868 (4022)	6,672 (3026)	6,672 (3026)
15 ft. (4.57 m)					11,093 (5032)	11,093 (5032)	9,940 (4509)	9,940 (4509)	9,351 (4242)	7,296 (3309)
10 ft. (3.05 m)					15,571 (7063)	15,571 (7063)	11,900 (5298)	10,193 (4623)	10,194 (4624)	7,044 (3195)
5 ft. (1.52 m)					20,080 (9108)	14,698 (6667)	14,025 (6362)	9,586 (4348)	11,224 (5091)	6,745 (3059)
Ground Line					22,077 (10 014)	14,018 (6358)	15,484 (7023)	9,142 (4147)	11,097 (5034)	6,500 (2948)
-5 ft. (-1.52 m)			14,178 (6431)	14,178 (6431)	21,813 (9894)	13,855 (6285)	15,489 (7026)	8,935 (4053)	10,961 (4972)	6,376 (2892)
-10 ft. (-3.05 m)	18,661 (8464)	18,661 (8464)	23,452 (10 638)	23,452 (10 638)	19,922 (9036)	13,696 (6336)	14,804 (6715)	8,952 (4061)	10,860 (4926)	6,436 (2919)
-15 ft. (-4.57 m)			20,995 (9523)	20,995 (9523)	15,959 (7239)	14,339 (6504)	11,521 (5226)	9,240 (4191)		

Buckets

225D LC

A full line of buckets is offered to meet a wide variety of applications. Digging forces are with power boost. Replaceable cutting edges are available through John Deere parts. Optional side cutters add 6 inches (150 mm) to bucket widths. Capacities are SAE heaped ratings.

Type Bucket	Bucket Width		Bucket Capacity		Weight		Bucket Dig Force		Arm Dig Force 7 ft. 11 in. (2.42 m)		Arm Dig Force 9 ft. 7 in. (2.91 m)		Bucket Tip Radius		No. Teeth
	in.	mm	cu. yd.	m ³	lb.	kg	lb.	kN	lb.	kN	lb.	kN	in.	mm	
General-Purpose High Capacity	30	760	0.79	0.60	1,432	650	28,904	128.6	27,806	123.7	22,873	101.7	58.00	1473	4
	36	915	1.00	0.76	1,621	736	28,904	128.6	27,806	123.7	22,873	101.7	58.00	1473	5
	42	1065	1.22	0.93	1,790	813	28,904	128.6	27,806	123.7	22,873	101.7	58.00	1473	5
	48	1220	1.43	1.09	1,976	897	28,904	128.6	27,806	123.7	22,873	101.7	58.00	1473	6
Heavy Duty	24	610	0.52	0.40	1,197	543	29,099	129.4	27,877	124.0	22,924	102.0	57.61	1463	4
	30	760	0.71	0.54	1,369	622	29,099	129.4	27,877	124.0	22,924	102.0	57.61	1463	4
	36	915	0.90	0.69	1,559	708	29,099	129.4	27,877	124.0	22,924	102.0	57.61	1463	5
	42	1065	1.09	0.83	1,731	786	29,099	129.4	27,877	124.0	22,924	102.0	57.61	1463	5
	48	1220	1.29	0.99	1,921	872	29,099	129.4	27,877	124.0	22,924	102.0	57.61	1463	6
Heavy-Duty High Capacity	24	610	0.56	0.43	1,424	646	28,904	128.6	27,806	123.7	22,873	101.7	58.00	1473	4
	30	760	0.76	0.58	1,593	723	28,904	128.6	27,806	123.7	22,873	101.7	58.00	1473	4
	36	915	0.97	0.74	1,782	809	28,904	128.6	27,806	123.7	22,873	101.7	58.00	1473	5
	42	1065	1.19	0.91	1,951	886	28,904	128.6	27,806	123.7	22,873	101.7	58.00	1473	5
Ditching	60	1500	1.14	0.87	1,271	577	40,279	179.2	31,133	138.5	25,271	112.4	41.62	1057	0

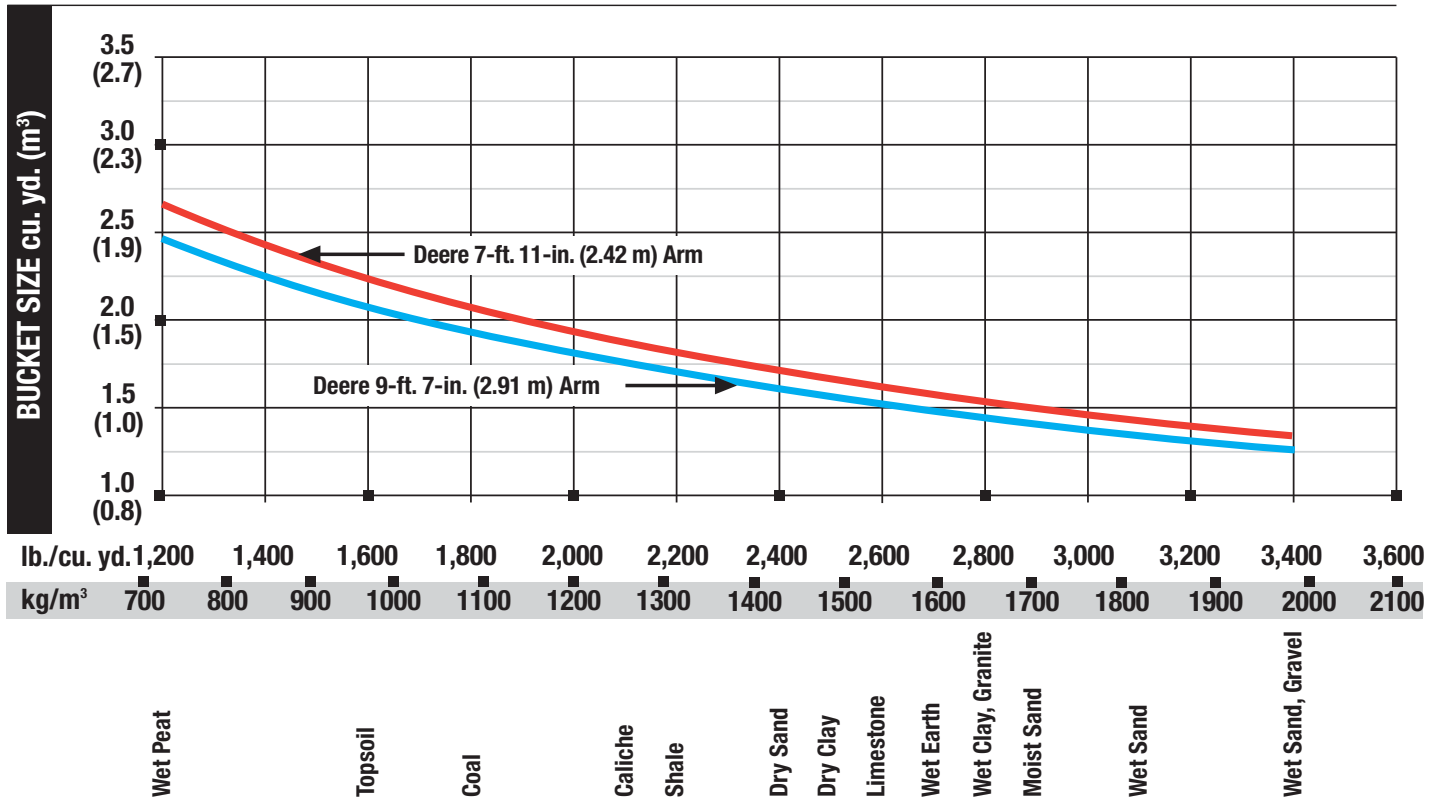

*Contact your John Deere dealer for optimum bucket and attachment selections. These recommendations are for general conditions and average use. Does not include optional equipment such as thumbs or couplers. Larger buckets may be possible when using light materials, for flat and level operations, less compacted materials, and volume loading applications such as mass excavation applications in ideal conditions. Smaller buckets are recommended for adverse conditions such as off-level applications, rocks, and uneven surfaces. Bucket capacity indicated is SAE heaped.

135D / 225D LC EXCAVATORS

Key: ● Standard equipment ▲ Optional equipment

See your John Deere dealer for further information.

135D	225D	Engine	135D	225D	Undercarriage (continued)	135D	225D	Operator's Station (continued)		
●	●	Meets EPA Tier 3/EU Stage IIIA emissions	▲		Rubber crawler pad, 20 in. (500 mm)	●	●	Hydraulic warm-up control		
●	●	Auto-idle system	▲		Triple semi-grouser shoes, 24 in. (600 mm)	●	●	Interior light		
●	●	Batteries (two 12 volt), 180-min. reserve capacity	▲	▲	Triple semi-grouser shoes, 28 in. (700 mm)	●	●	Large cup holder		
●	●	Coolant recovery tank	▲	▲	Triple semi-grouser shoes, 32 in. (800 mm)	●	●	Machine Information Center (MIC)		
●	●	Dual-element dry-type air filter	▲		Undercarriage with blade	●	●	Mode selectors (illuminated): Power modes – three / Travel modes – two with automatic shift / Work mode – one		
●	●	Electronic engine control			Upperstructure	●	●	Multifunction, color LCD monitor with: Diagnostic capability / Multiple-language capabilities / Maintenance tracking / Clock / System monitoring with alarm features: Auto-idle indicator, engine air cleaner restriction indicator light, engine check, engine coolant temperature indicator light with audible alarm, engine oil pressure indicator light with audible alarm, low-alternator-charge indicator light, low-fuel indicator light, fault-code alert indicator, fuel-rate display, wiper-mode indicator, work-lights-on indicator, and work-mode indicator		
●	●	Enclosed fan guard (conforms to SAE J1308)			●	●	Right- and left-hand mirrors	●	●	Motion alarm with cancel switch (conforms to SAE J994)
●	●	Engine coolant to -34 deg. F (-37 deg. C)			●	●	Vandal locks with ignition key: Cab door / Fuel cap / Service doors / Toolbox	●	●	Power-boost switch on right console lever
●	●	Fuel filter with water separator			●	●	Remote-mounted engine oil and fuel filters	●	●	Auxiliary hydraulic control switches in right console lever
●	●	Full-flow oil filter					Front Attachments	●	●	SAE two-lever control pattern
●	●	Turbocharger with charge air cooler			●	●	Centralized lubrication system	●	●	Seat belt, 2 in. (51 mm), retractable
●	●	Muffler, under hood, with vertical curved end exhaust stack			●	●	Dirt seals on all bucket pins	●	●	Tinted glass
●	●	Radiator, oil cooler, and intercooler with dust-protective net			●	●	Less boom and arm	●	●	Transparent tinted overhead hatch
●	●	Glow-plug start aid			●	●	Oil-impregnated bushings	●	●	Hot/cold beverage compartment
●	●	500-hour engine oil-change interval			●	●	Reinforced resin thrust plates	▲	▲	Seat belt, 3 in. (76 mm), non-retractable
●	●	70% (35 deg.) off-level capability			●	●	Tungsten carbide thermal coating on arm-to-bucket joint	▲	▲	Monitor system with alarm features: Hydraulic oil filter restriction indicator light
●	●	Isolation mounted			▲	▲	Arm, 7 ft. 11 in. (2.42 m)	▲	▲	Air-suspension heated seat
●	●	Engine oil-drain coupler			▲	▲	Arm, 8 ft. 3 in. (2.52 m)	▲	▲	24- to 12-volt D.C. radio converters, 10 amp
		Hydraulic System			▲	▲	Arm, 9 ft. 7 in. (2.91 m)	▲	▲	Circulation fan
●	●	Reduced-drift valve for boom down, arm in			▲	▲	Attachment quick-couplers	▲	▲	Protection screens for cab front, rear, and side
●	●	Auxiliary hydraulic valve section			▲	▲	Boom cylinder with plumbing to mainframe for less boom and arm	▲	▲	Window vandal protection covers
●	●	Spring-applied, hydraulically released automatic swing brake			▲	▲	Buckets: Ditching / Heavy duty / Heavy-duty high capacity / Side cutters and teeth			Electrical
●	●	Auxiliary hydraulic-flow adjustments through monitor			▲	▲	Material clamps	●	●	50-amp alternator
●	●	Auto power lift					Operator's Station	●	●	Blade-type multi-fused circuits
●	●	5,000-hour hydraulic oil-change interval			●	●	Adjustable independent control positions (levers-to-seat, seat-to-pedals)	●	●	Positive terminal battery covers
▲	▲	Auxiliary hydraulic lines			●	●	AM/FM radio	●	●	JDLINK™ Ultimate wireless communication system with 3 years of service
▲	▲	Auxiliary pilot and electric controls			●	●	Auto climate control/air conditioner, 20,000 Btu/hr. (5.9 kW), with heater and pressurizer	▲	▲	JDLINK wireless communication system
▲	▲	Hydraulic filter restriction indicator kit			●	●	Built-in operator's manual storage compartment and manual			Lights
▲	▲	Load-lowering control device			●	●	Cell-phone power outlet, 12 volt, 60 watt, 5 amp	●	●	Work lights: Halogen / One mounted on boom / One mounted on frame
▲	▲	Single-pedal propel control			●	●	Coat hook			
▲	▲	Control pattern-change valve			●	●	Deluxe suspension cloth seat with 4-in. (100 mm) adjustable armrests			
		Undercarriage			●	●	Floor mat			
●	●	Planetary drive with axial piston motors			●	●	Front windshield wiper with intermittent speeds			
●	●	Propel motor shields			●	●	Gauges (illuminated): Engine coolant / Fuel			
●	●	Spring-applied, hydraulically released automatic propel brake			●	●	Horn, electric			
●	●	Track guides, front idler			●	●	Hour meter, electric			
●	●	Track guides, front idler and center			●	●	Hydraulic shutoff lever, all controls			
●	●	Two-speed propel with automatic shift								
●	●	Upper carrier roller (1)								
●	●	Upper carrier rollers (2)								
●	●	Sealed and lubricated track chain								

CONTROL OWNING AND OPERATING COSTS

Customer Personal Service (CPS) is part of John Deere's proactive, fix-before-fail strategy on machine maintenance that will help control costs, increase profits, and reduce stress. Included in this comprehensive lineup of ongoing programs and services are:

Fluid analysis program – tells you what's going on inside *all* of your machine's major components so you'll know if there's a problem *before* you see a decline in performance. Fluid analysis is included in most extended coverage and preventive-maintenance agreements.

Component life-cycle data – gives you vital information on the projected life span of components and lets you make informed decisions on machine maintenance by telling you approximately how many hours of use you can expect from an engine, transmission, or hydraulic pump. This information can be used to preempt catastrophic downtime by servicing major components at about 80 percent of their life cycle.

Preventive Maintenance (PM) agreements – give you a fixed cost for maintaining a machine for a given period of time. They also help you avoid downtime by ensuring that critical maintenance

work gets done right and on schedule. On-site preventive maintenance service performed where and when you need it helps protect you from the expense of catastrophic failures and lets you avoid waste-disposal hassles.

Extended coverage – gives you a fixed cost for machine repairs for a given period of time so you can effectively manage costs. Whether you work in a severe-service setting or just want to spread the risk of doing business, this is a great way to custom-fit coverage for your operation. And an extended coverage contract also travels well because it's backed by John Deere and is honored by *all* Deere construction dealers.

Customer Support Advisors (CSAs) – Deere believes the CSA program lends a *personal* quality to Customer Personal Service (CPS). Certified CSAs have the knowledge and skills for helping make important decisions on machine maintenance and repair. Their mission is to help you implement a plan that's right for *your* business and take the burden of machine maintenance off your shoulders.



JOHN DEERE

02-04-10

Net engine power is with standard equipment including air cleaner, exhaust system, alternator, and cooling fan at test conditions per ISO9249. No derating is required up to 10,000-ft. (3050 m) altitude.

Specifications and design subject to change without notice. Wherever applicable, specifications are in accordance with SAE standards. Except where otherwise noted, these specifications are based on units with full fuel tanks and 175-lb. (79 kg) operators; a 135D unit with 30-in. (762 mm), 0.66-cu.-yd. (0.50 m³), 1,023-lb. (464 kg) bucket, 9-ft. 11-in. (3.01 m) arm, 28-in. (700 mm) triple semi-grouser shoes, and 8,113-lb. (3680 kg) counterweight; and a 225D LC unit with 42-in. (1067 mm), 1.09-cu.-yd. (0.83 m³), 1,731-lb. (721 kg) heavy-duty bucket, 9-ft. 7-in. (2.91 m) arm, 32-in. (800 mm) triple semi-grouser shoes, and 16,710-lb. (7586 kg) counterweight.



Free Manuals Download Website

<http://myh66.com>

<http://usermanuals.us>

<http://www.somanuals.com>

<http://www.4manuals.cc>

<http://www.manual-lib.com>

<http://www.404manual.com>

<http://www.luxmanual.com>

<http://aubethermostatmanual.com>

Golf course search by state

<http://golfingnear.com>

Email search by domain

<http://emailbydomain.com>

Auto manuals search

<http://auto.somanuals.com>

TV manuals search

<http://tv.somanuals.com>