

JLDW 1225 Dishwasher

Instruction manual

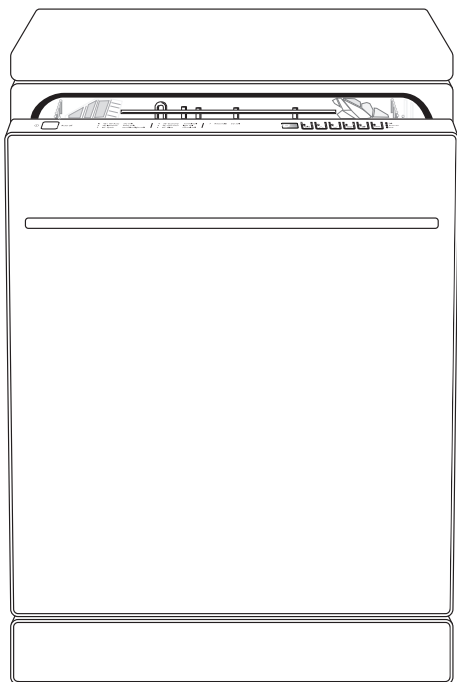

John Lewis



Important safety information

It is most important that this instruction book should be retained with the appliance for future reference. Should the appliance be sold or transferred to another owner, or should you move house and leave the appliance, always ensure that the book is supplied with the appliance in order that the new owner can get to know the functioning of the appliance and the relevant warnings.

These warnings have been provided in the interest of safety. You **MUST** read them carefully before installing or using the appliance. If you are unsure of the meanings of these warnings contact the John Lewis branch from which you purchased the appliance.



In the interest of your safety and to ensure the correct use, before installing and first using the appliance, read this user manual carefully, including its hints and warnings. To avoid unnecessary mistakes and accidents, it is important to ensure that all people using the appliance are thoroughly familiar with its operation and safety features. Save these instructions and make sure that they remain with the appliance if it is moved or sold, so that everyone using it through its life will be properly informed on appliance use and safety.

If you are unsure of the meanings of these warnings contact the John Lewis branch from which you purchased the appliance.

- Check the appliance for any transport damage. Never connect a damaged machine. If the appliance is damaged contact your supplier.
- All packaging must be removed before use.
- Any electrical work required to install this appliance must be carried out by a qualified electrician.
- Any plumbing work required to install this appliance must be carried out by a qualified plumber.
- For safety reasons it is dangerous to alter the specifications or attempt to modify this product in any way.
- Never use the appliance if the electrical supply cable and water hoses are damaged; or if the control panel, work top or plinth area are damaged such that the inside of the appliance is freely accessible. Contact your local repair agent, in order to avoid hazard.
- All sides of the appliance must never be drilled to prevent damage to hydraulic and electric components.

Installation

- This appliance is heavy. Care should be taken when moving it.



For electrical and water connection carefully follow the instructions given in the specific paragraphs.

- Under no circumstances should you attempt to repair the appliance yourself. Repairs carried out by inexperienced persons could cause injury or serious malfunctioning. Contact your local repair agent. Always insist on genuine spare parts.

Child safety

- This appliance is designed to be operated by adults. Children should not be allowed to tamper with the controls or play with the appliance.
- Keep all packaging well away from children. There is a risk of suffocation.
- Keep all detergents in a safe place out of children's reach.
- Keep children well away from the appliance when the door is open.

Correct use

- This appliance is only intended for washing household utensils suitable for machine washing.
- Do not put any solvents in the appliance. This could cause an explosion.
- Knives and other items with sharp points must be loaded in the cutlery basket with their points down or placed in a horizontal position in the upper basket.
- Only use products (detergent, salt and rinse aid) suitable for dishwashers.
- Avoid opening the door whilst the appliance is in operation, hot steam may escape.
- Do not take any dishes out of the appliance before the end of the washing programme.
- After use, isolate the appliance from the power supply and turn off the water supply.
- This product should be serviced only by an authorised service engineer, and only genuine spare parts should be used.

General safety

- Persons (including children) with reduced physical sensory, mental capabilities or lack of experience and knowledge must not use the appliance. They must have supervision or instruction for the operation of the appliance by a person responsible for their safety.
- Dishwasher detergents can cause chemical burns to eyes, mouth and throat. Could endanger life! Comply with the safety instructions of the dishwasher detergent manufacturer.
- The water in your appliance is not for drinking. Detergent residue may still be present in the appliance.
- Ensure that the appliance door is always closed when it is not being loaded or unloaded. In this way you will avoid anybody tripping over the open door and hurting themselves.
- Do not sit or stand on the open door.

Maintenance and cleaning

- For information on maintenance and cleaning your appliance see the specific chapter in this instruction manual.

Service

- This product should be serviced by an authorised service engineer and only genuine spare parts should be used.



Ecological hints

To save water and energy and help protect the environment, we recommend that you follow these hints:

- Ensure that the water softener is correctly adjusted.
- Do not prewash under running water.
- Select the washing programme to suit the nature and degree of the soil on the dishes.
- Do not use more detergent, dishwasher salt and rinse aid than is recommended in these operating instructions and by the manufacturer of the respective product.
- **Delay start:** When possible set your appliance to run over night, to enable, for example, the use of economical overnight electricity tariffs.
- **45° - 70° Auto Programme:** This appliance is fitted with a turbidity sensor which intelligently adjusts the temperature and rinsing phases during the washing programme, depending on the degree of soil on the dishes. This helps to reduce energy and water consumption on lightly soiled loads.

- **Energy save:** This function decreases the temperature in the drying phase. The power consumption is reduced by 25%

Environmental information

The packaging materials are environmentally friendly and can be recycled. The plastic components are identified by markings (e.g. >PE<, >PS<) . Please dispose of the packaging materials in the appropriate container at the community waste disposal facilities.



When a unit is no longer being used:

- Pull the mains plug out of the mains socket.
 - Cut off the mains cable and the mains plug and dispose of them.
 - Dispose of the door catch. This prevents children from trapping themselves inside and endangering their lives.
-

Contents

For the user

Important safety information 2

Description of the appliance 6

Visual signal 6

Control panel 7

Washing programmes 9

When the appliance is first installed 11

The water softener 11

Filling with salt 13

Filling with rinse aid 13

Daily use 14

Loading cutlery and dishes 14

Use of detergent 18

Multi tab function 19

Select and start a washing programme 20

Unloading the appliance 21

Maintenance and cleaning 22

Cleaning the filters 22

Cleaning the appliance 23

Prolonged periods of non-operation 23

Frost precautions 23

Moving the appliance 23

Something not working 24

For the installer

Technical data 27

Installation 27

Water connection 29

Electrical connection 31

Repairs - after sales service 32

Guide to use the instruction manual

The following symbols will be found in the text to guide you throughout the instructions:



Safety instructions



Hints and tips



Environmental information

Description of the appliance

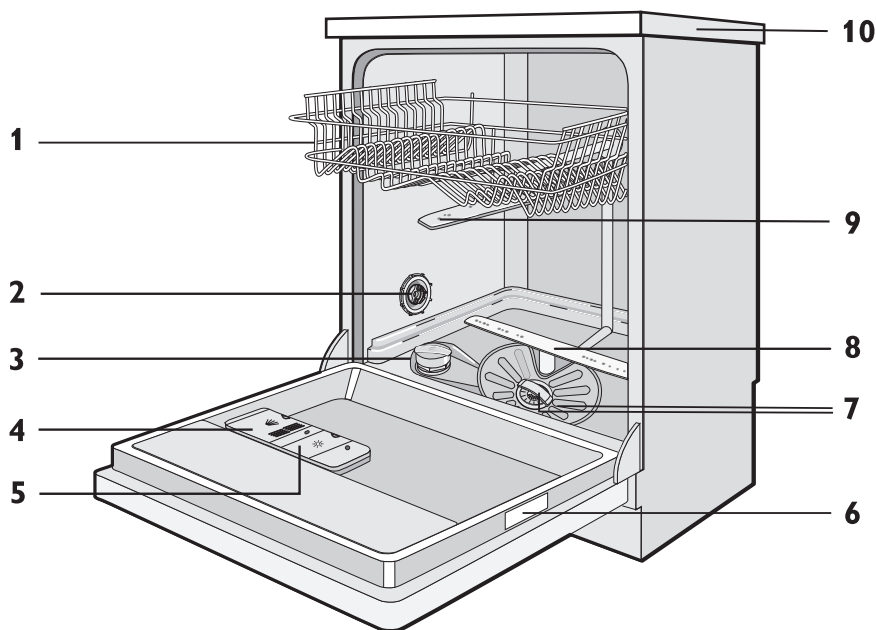

1. Upper basket
2. Water hardness dial
3. Salt container
4. Detergent dispenser
5. Rinse aid dispenser
6. Rating plate
7. Filters
8. Lower spray arm
9. Upper spray arm
10. Worktop

signal remains visible until the washing programme is completed.

- When the washing programme has ended, a green visual signal shows on the floor beneath the appliance door.
- When a malfunction of the appliance occurs, a red visual signal flashes on the floor beneath the appliance door.

Visual signal

- When the washing programme starts, a red visual signal shows on the floor beneath the appliance door. This red

Control panel

i The controls are on the top on the control panel. To operate with the controls, keep the appliance door ajar.

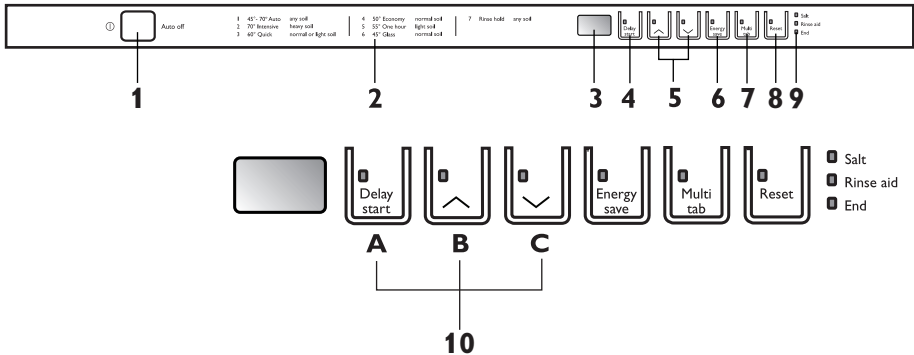

1. On/off button
2. Programme guide
3. Display
4. Delay start button
5. Programme buttons
6. Energy save button
7. Multi tab button
8. Reset button
9. Indicators
10. Function buttons

On/off button

Press this button to switch on or off the appliance.

After ten minutes from the end of the washing programme, the Auto off function automatically switches off the appliance. This helps to reduce energy consumption.

The display

The display shows:

- The water hardness adjustment of the water softener.
- The washing programme number.
- The remaining time of the programme in progress.
- The activation or deactivation of the rinse aid dispenser (only with the Multi tab function activated).
- The end of a washing programme (the display shows a zero).
- The countdown of the delay start.
- The alarm codes related to a malfunction of the appliance.
- The activation or deactivation of the acoustic signals.

Delay start button

Press this button to delay the start of the washing programme from 1 to 24 hours. Refer to 'Select and start a washing programme'.

Programme buttons

To select a washing programme, press one of these buttons until the display shows the programme number.

Energy save button

This function decreases the temperature in the drying phase. The power consumption is reduced by 25%.

Dishes can still be wet at the end of the programme when you open the appliance door. We recommend that you keep the door ajar and let the dishes dry.

Indicators

Salt ¹⁾	The indicator comes on when the salt has run out. The salt indicator can remain on for a few hours after that salt has been replenished (assuming the appliance remains switched on). The operation of the appliance is not affected.
Rinse aid ¹⁾	The indicator comes on when the rinse aid has run out.
End	The indicator comes on when the washing programme ends.

¹⁾ The salt and rinse aid indicators are never on while a washing programme is running even if filling with salt and/or rinse aid is necessary.

Function buttons

The following operations can be done with these buttons:

Press this button to switch on the option. The related indicator comes on. This function is available with all the washing programmes but has no impact on some programmes. Refer to "Washing programmes".

Multi tab button

Allows the use of combi detergent tablets (e.g. 3 in 1, 4 in 1, 5 in 1). Refer to "Multi tab function".

Reset button

Press this button to cancel a washing programme in progress.

- The electronic setting of the water softener.
- The cancellation of a washing programme in progress.
- The activation or deactivation of the rinse aid dispenser (only with the Multi tab function activated).
- Activation or deactivation of the acoustic signals.

Setting mode

The appliance must be in setting mode for these operations:

- To start a washing programme.
- To start a delay start.
- To adjust electronically the level of the water softener.

- To activate or deactivate the rinse aid dispenser (only with the Multi tab function activated).
- To activate or deactivate the acoustic signals.

Switch on the appliance. The appliance is in setting mode when:

- The display shows two horizontal status bars.

Switch on the appliance. The appliance is not in setting mode when:

- The display shows the time of the washing programme or of the delay start.
 - Cancel the programme or the delay start to go back to the setting mode. Refer to 'Select and start a washing programme'.

Acoustic signals

The acoustic signals indicate:

- The electronic setting of the water softener.
- The end of the washing programme.
- The intervention of an alarm code related to a malfunction.

Factory setting: acoustic signals activated.

It is possible to deactivate the audible signals, using the function buttons on the control panel.

Deactivating the acoustic signals

1. Switch on the appliance. Make sure that the appliance is in setting mode.
2. Press and hold function button **(B)** and function button **(C)** simultaneously until the indicators of function buttons **(A)**, **(B)** and **(C)** start to flash.
3. Release function button **(B)** and function button **(C)**.
4. Press function button **(C)**, the indicators of function buttons **(A)** and **(B)** go off while the indicator of function button **(C)** continues to flash. The display shows the current setting of the acoustic signals.

<i>0b</i> Acoustic signals deactivated
--

<i>1b</i> Acoustic signals activated

5. Press function button **(C)** again to change the setting. The display shows the new setting.
6. Switch off the appliance to confirm the operation.

To activate the acoustic signals again, do steps **(1)** through **(6)**.

Washing programmes

Programme	Degree of soil and type of load	Programme description	Energy save function
1 45°-70° Auto ¹⁾	Any soil. Crockery, cutlery, pots and pans.	Prewash Wash 45 °C or 70 °C Rinses Dry	YES (impact on washing programme)

Programme	Degree of soil and type of load	Programme description	Energy save function
2 70° Intensive	Heavy soil. Crockery, cutlery, pots and pans.	Prewash Wash 70 °C Rinses Dry	YES (impact on washing programme)
3 60° Quick ²⁾	Normal or light soil. Crockery and cutlery.	Wash 60 °C Rinse	YES (no impact on washing programme)
4 50° Economy ³⁾	Normal soil. Crockery and cutlery.	Prewash Wash 50 °C Rinses Dry	YES (impact on washing programme)
5 55° One hour	Light soil. Crockery and cutlery.	Wash 55 °C Rinses	YES (no impact on washing programme)
6 45° Glass	Normal soil. Delicate crockery and glassware.	Wash 45 °C Rinses Dry	YES (impact on washing programme)
7 Rinse hold	Any soil. Partial load (to be completed later in the day). This programme does not require the use of detergent.	Rinse	YES (no impact on washing programme)

- 1) The appliance senses the type of soil and the quantity of items in the baskets. It automatically adjusts the temperature and quantity of the water, the energy consumption and the programme time.
- 2) Ideal for washing a partially loaded dishwasher. This is the perfect daily programme, made to meet the needs of a family of **4 persons** who only wish to load breakfast and dinner crockery and cutlery.
- 3) This is the standard programme for test institutes. With this programme you have the most efficient use of water and energy consumption for crockery and cutlery with normal soil.

Consumption values

Programme	Programme time (minute)	Energy (kWh)	Water (litre)
1 45°-70° Auto	90 - 160	0.9 - 1.7	8 - 15
2 70° Intensive	130 - 150	1.4 - 1.5	13 - 14
3 60° Quick	30	0.9	9
4 50° economy	160 - 170	0.9 - 1.0	9 - 11

Programme	Programme time (minute)	Energy (kWh)	Water (litre)
5 55° One hour	50 - 60	1.0 - 1.2	10 - 11
6 45° Glass	65 - 75	0.8 - 0.9	11 - 12
7 Rinse hold	14	0.1	4



The consumption values are intended as a guide. They depend on the pressure and the temperature of the water, on the variations of the power supply and on the quantity of dishes.

When the appliance is first installed

Before using the appliance for the first time:

- Ensure that the electrical and water connections comply with the installation instructions
- Remove all packaging from inside the appliance.
- Check if the factory set of the water softener complies with the water hardness in your area. If not, adjust the level of the water softener.
- Pour 1 litre of water into the salt container and then fill with dishwasher salt.
- Fill the rinse aid dispenser.



If you want to use combi detergent tablets (e.g. 3 in 1, 4 in 1, 5 in 1) set the Multi tab function. Refer to 'Multi tab function'.

The water softener

The appliance is equipped with a water softener designed to remove minerals and salts from the water supply, which would have a detrimental or adverse effect on the operation of the appliance.

The higher the content of these minerals and salts, the harder your water is. Water hardness is measured in equivalent scales, Clarke degrees, French degrees (°TH) and mmol/l (millimol per litre - international unit for the hardness of water).

The softener should be adjusted according to the hardness of the water in your area. Your local Water Authority can advise you on the hardness of the water in your area.

Water hardness			Adjustment of the water softener		Use of salt
Clarke	°TH	mmol/l	manually	electronically	
64 - 88	91 - 125	9.1 - 12.5	2	level 10	yes
53 - 63	76 - 90	7.6 - 8.9	2	level 9	yes
46 - 52	65 - 75	6.5 - 7.5	2	level 8	yes
36 - 45	51 - 64	5.1 - 6.4	2	level 7	yes
28 - 35	40 - 50	4.0 - 5.0	2	level 6	yes
23 - 27	33 - 39	3.3 - 3.9	2	level 5	yes
18 - 22	26 - 32	2.6 - 3.2	1	level 4	yes
13 - 17	19 - 25	1.9 - 2.5	1	level 3	yes
5 - 12	7 - 18	0.7 - 1.8	1	level 2	yes
< 5	< 7	< 0.7	1	level 1	no

i The water softener must be set in two ways, manually and electronically.

Setting manually

The appliance is factory set at position 2.

1. Open the appliance door.
2. Remove the lower basket from the appliance.
3. Turn the water hardness dial to position 1 or 2. Refer to the water hardness table.
4. Replace the lower basket.

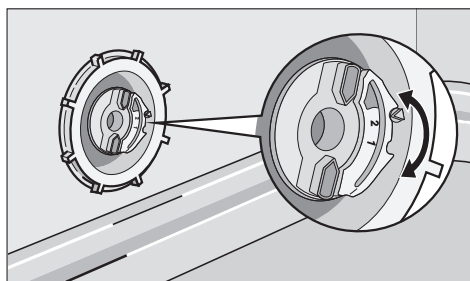

Setting electronically

The appliance is factory set at level 5.

1. Switch on the appliance. Make sure that the appliance is in setting mode.
2. Press and hold function button **(B)** and function button **(C)** simultaneously until the indicators of function buttons **(A)**, **(B)** and **(C)** start to flash.
3. Release function button **(B)** and function button **(C)**.
4. Press function button **(A)**, the indicators of function buttons **(B)** and **(C)** go off while the indicator of function button **(A)** continues to flash.
 - The acoustic signals sound.
 - The display shows the current level (e.g. **5 L** displayed and you hear 5 acoustic signals = level 5).
5. To change the level, go on pressing function button **(A)** until the display shows the required level. Refer to the water hardness table.
6. Switch off the appliance to confirm the operation.

Filling with salt



Caution! Only use salt specifically designed for dishwasher use. All other types of salt, especially table salt, will damage the water softener. Only fill with salt just before starting one of the complete washing programmes. This will prevent any grains of salt or salty water, which may have been spilt, to remain on the bottom of the appliance for any period of time and cause corrosion.

1. Open the appliance door and remove the lower basket.
2. Unscrew the cap of the salt container by turning it anticlockwise.
3. Pour 1 litre of water into the container (this is necessary only before filling with salt for the first time).
4. Using the funnel provided, pour in the salt until the container is full.



5. Screw on the cap of the salt container by turning it clockwise until it stops with a click. Make sure that there is no trace of salt on the screw thread or on the gasket.



Do not worry if water overflows from the unit when filling with salt, this is quite normal.

Filling with rinse aid

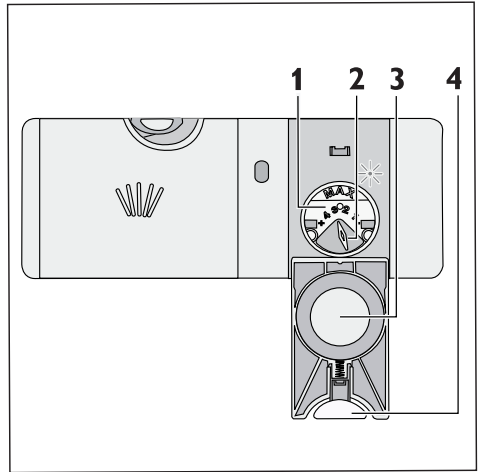

Caution! Only use branded rinse aid for dishwashers. Never fill the rinse aid dispenser with any other substances (e.g. dishwasher cleaning agent, liquid detergent). This would damage the appliance.



Rinse aid ensures thorough rinsing, and spot and streak free drying. Rinse aid is automatically added during the last rinse.

1. Press the release button (4) to open the lid (3) of the rinse aid dispenser.
2. Fill the rinse aid dispenser (1) with rinse aid. The maximum level for filling is indicated by 'max'.
3. Clean up any rinse aid spilt during filling with an absorbent cloth to avoid excess foaming during the next washing programme.

4. Close the rinse aid dispenser. Press the lid until it locks into position.

Adjusting the rinse aid dosage

The factory set in position 3.

You can set the rinse aid dosage between position 1 (lowest dosage) and position 4 (highest dosage).
Turn the rinse aid selector (**2**) to increase or reduce the dosage.

Daily use

- Check if it's necessary to refill with dishwasher salt or rinse aid.
- Open the door, slide out the baskets and load cutlery and dishes.
- Fill the detergent dispenser with detergent.
- Select a washing programme suitable for the degree of soil and the type of load.
- Start the washing programme.
- Dishes and cutlery must not impede the rotation of the spray arms.
- Load hollow items with the opening downwards so that water cannot collect in the container or a deep base.
- Dishes and items of cutlery must not lie inside one another or cover each other.
- To avoid damage to glasses, they must not touch.
- Lay small objects in the cutlery basket.
- Plastic items and pans with non stick coatings have a tendency to retain water drops. These items will not dry as well as porcelain and steel items.
- Light items (e.g. plastic bowls) must be loaded in the upper basket and arranged so they do not move.

Loading cutlery and dishes

Sponges, household cloths and any object that can absorb water must not be washed in the appliance.

- Remove all left over food and debris from dishes.
- Soften remnants of burnt food in pans.

For washing in the dishwasher the following cutlery and dishes

are not suitable:

- Cutlery with wooden, horn, china or mother-of-pearls handles.
- Plastic items that are not heat resistant.
- Older cutlery with glued parts that are not temperature resistant.
- Bonded cutlery items or dishes.
- Pewter or copper items.
- Lead crystal glass.
- Steel items prone to rusting.
- Wooden platters.
- Items made from synthetic fibres.

are of limited suitability:

- Only wash stoneware if it is specially marked as being dishwasher-safe by the manufacturer.
- Glazed patterns may fade if machine washed frequently.
- Silver and aluminium parts have a tendency to discolour during washing: Residue, e.g. egg white, egg yolk and mustard often cause discolouring and staining on silver. Therefore always clean left-overs from silver immediately, if it is not to be washed straight after use.

The lower basket

The lower basket is designed to take pots, pans, lids, dishes, salad bowls and cutlery. The rows of prongs in the lower basket can lie flat to allow you to load pots, pans and bowls.

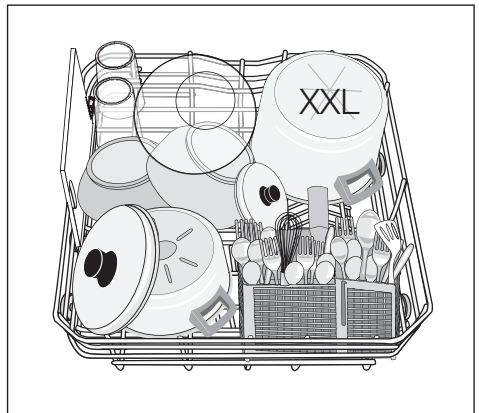
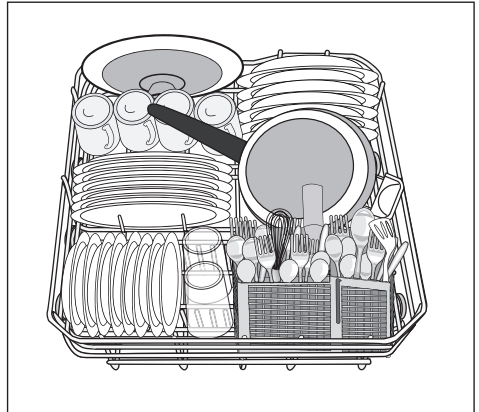
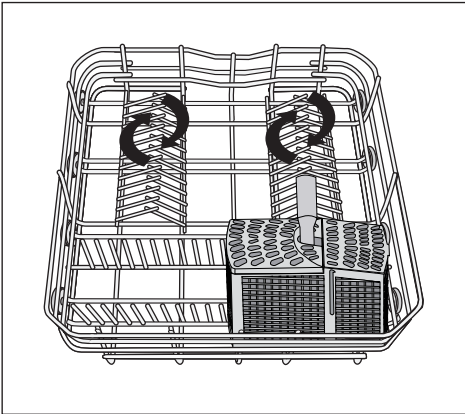

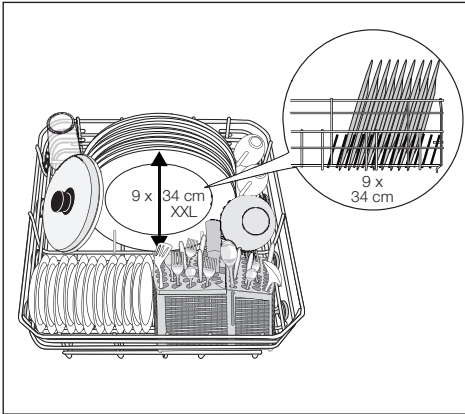

The cutlery basket



Warning! Knives with long blades, stored in an upright position, are a potential hazard. Long and/or sharp items of cutlery such as carving knives must be positioned horizontally in the upper basket. Take care when loading or unloading sharp items such as knives. Forks and spoons should be placed in the removable cutlery basket with the handles facing downwards and the knives with their handles facing upwards

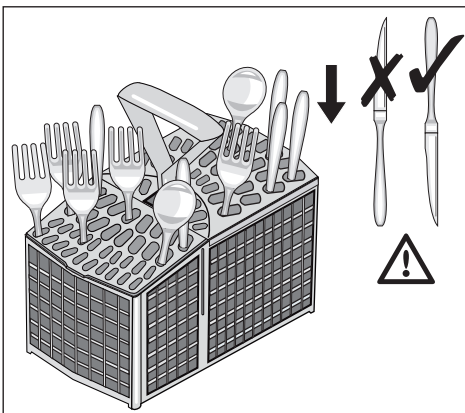
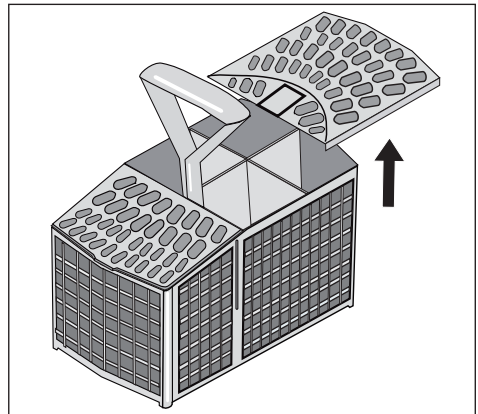
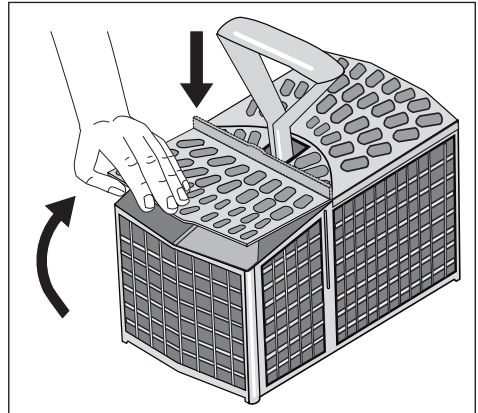

The upper basket

Arrange items on and underneath the cup racks so that water can reach all surfaces.

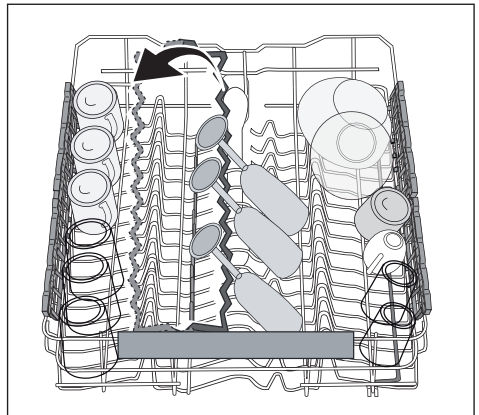
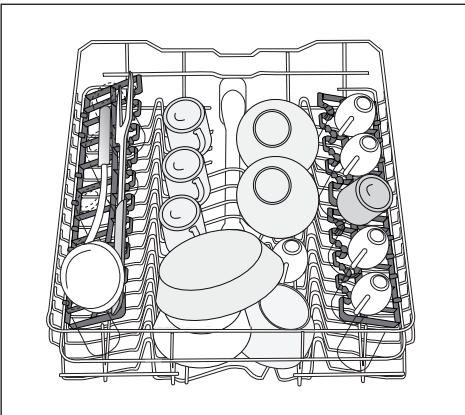
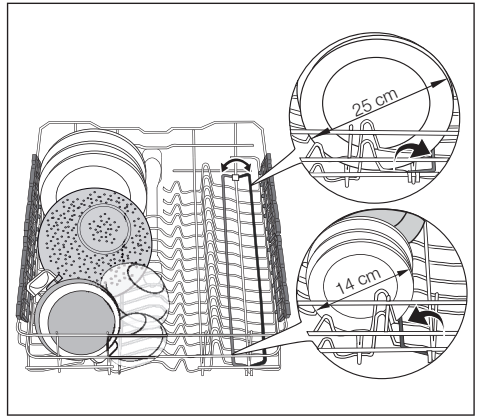
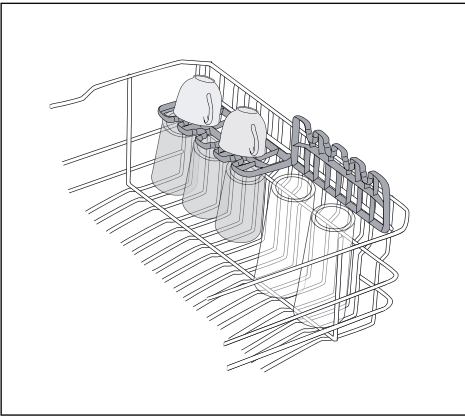
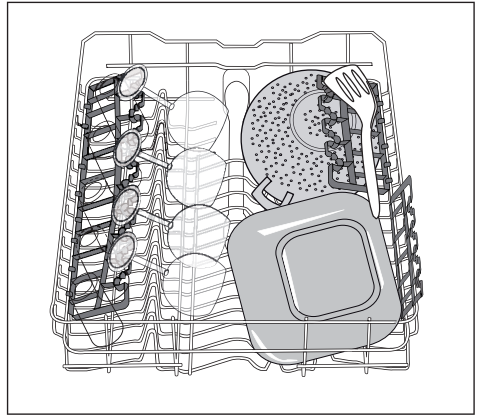
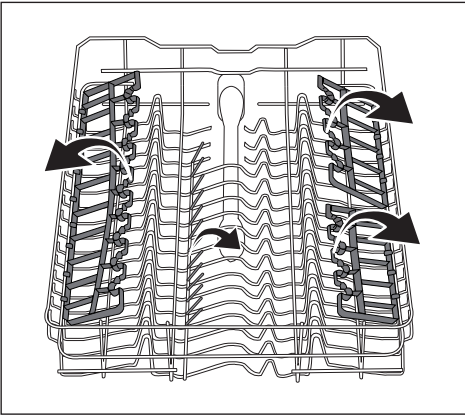



Caution! Ensure that the spray arms can rotate freely before you close the appliance door.

Adjusting the height of the upper basket

To load very large plates move the upper basket to the higher position.

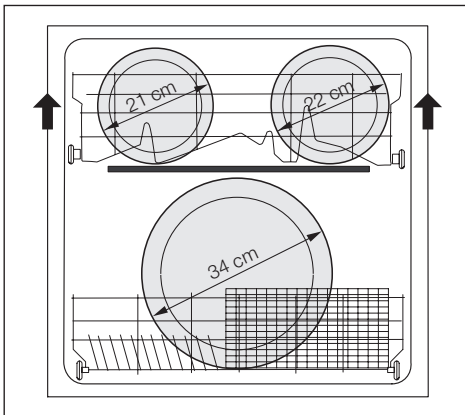
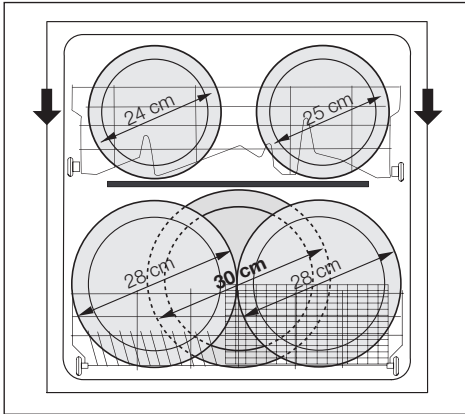

Moving the upper basket to the higher position

1. Pull out the basket until it stops.
2. Carefully lift both sides upwards until the mechanism is engaged and the basket is stable.

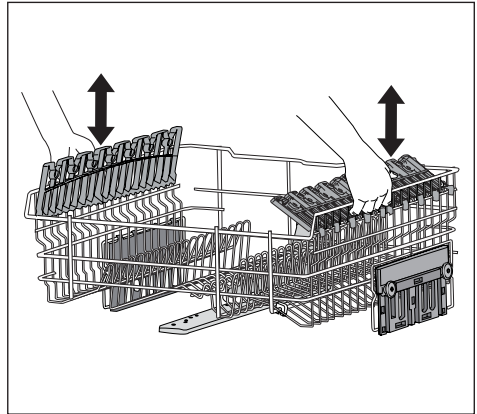

Moving back the upper basket to the lower position

1. Pull out the basket until it stops.
2. Carefully lift both sides upwards and then allow the mechanism to drop back down slowly, keeping hold of it.



Caution! Never lift or lower the basket on one side only.



Warning! Always close the appliance door after loading the baskets. An open door can be a hazard.

Use of detergent



Caution! Only use detergents specifically designed for use in dishwashers. Please observe the dosing and storage recommendations as stated on the detergent packaging.



Using no more than the correct amount of detergent contributes to reducing pollution.

Fill with detergent

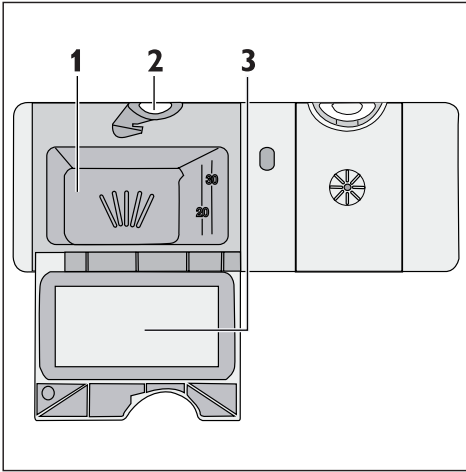

1. Press the release button (2) to open the lid (3) of the detergent dispenser.

2. Put the detergent in compartment (1).
3. If the washing programme has a prewash phase, put a small quantity of detergent on the inner side of the appliance door.
4. If you use detergent tablets, put the tablet in compartment (1).
5. Close the lid. Make sure that it locks into position.



Detergent tablets from different manufacturers dissolve at different rates. For this reason, some detergent tablets do not attain their full cleaning power during short washing programmes. Therefore, please use long washing programmes when using detergent tablets, to ensure the complete removal of detergent residual.

Multi tab function

This appliance is equipped with the Multi tab function, that allows the use of combi detergent tablets.

These products are detergents with a combined cleaning, rinsing and salt functions. They can also contain other different agents depending on which kind of tablets you choose (e.g. 3 in 1, 4 in 1, 5 in 1).

Check whether these detergents are suitable for your water hardness. Refer to the manufacturer's instructions.

The Multi tab function deactivates the inflow of rinse aid and salt from each respective supply container. Also the indicators for salt and rinse aid are deactivated.

The Multi tab function can increase the programme time that will automatically be updated on the display.

Activate the Multi tab function before the start of a washing programme.



Activate or deactivate the Multi tab function before the start of a washing programme. You cannot activate or deactivate the function when a washing programme is in progress.

To activate the Multi tab function

- Press the Multi tab button, the Multi tab indicator comes on. The function has been activated.
 - When the Multi tab function is activated, it remains on until you deactivate it.

To deactivate the Multi tab function and use separately detergent, salt and rinse aid

1. Press the Multi tab button, the Multi tab indicator goes off. The function has been deactivated.
2. Fill the salt container and the rinse aid dispenser.

3. Adjust the water hardness to the highest level.
4. Perform a washing programme without loading any dishes.
5. When the washing programme is completed, adjust the water softener to the water hardness in your area.
6. Adjust the rinse aid dosage.

Select and start a washing programme

Starting the washing programme without delay start

1. Switch on the appliance. Make sure that the appliance is in setting mode.
2. Select a washing programme. Refer to 'Washing programmes'.
 - The related programme number flashes in the display.
3. Close the appliance door. The washing programme starts automatically.

Starting the washing programme with delay start

1. Switch on the appliance. Make sure that the appliance is in setting mode.
2. Select a washing programme.
3. Press the delay start button until the display shows the hours for the delay start.
 - The hours flash in the display.
 - The delay start indicator comes on.

4. Close the appliance door. The countdown starts automatically.
 - When the countdown is completed, the washing programme starts automatically.



The opening of the appliance door interrupts the countdown. When you close the door, the countdown continues from the point of interruption.

Cancelling the delay start

The appliance door is still open and the countdown has not yet started

1. Press the delay start button until the display shows the number of the selected washing programme.
 - The programme number flashes.
2. Close the appliance door. The washing programme starts automatically.

The appliance door is closed and the countdown is in progress

1. Open the appliance door.

2. Press the delay start button until the display shows the number of the selected washing programme.
 - The programme number flashes for a few seconds and then the time of the washing programme comes on.
3. Close the appliance door. The washing programme starts automatically.



Warning! Interrupt or cancel a washing programme in progress only if it's absolutely necessary. Hot steam may escape when the appliance door is opened. Open the door carefully.

- Press and hold the Reset button until the display shows two horizontal status bars. The washing programme has been cancelled.



Make sure that there is detergent in the detergent dispenser before you start a new washing programme.

End of the washing programme

When the washing programme is completed, an intermittent acoustic signal sounds.

1. Open the appliance door.
 - The display shows a zero.
 - The End indicator is on.
2. Switch off the appliance.



Leave the door ajar and wait a few minutes before removing the dishes. In this way they will be cooler and the drying will be improved.



It is recommended that the appliance is unplugged and the water tap turned off when the washing programme is completed.

Interrupting a washing programme in progress

1. Open the appliance door. The washing programme stops.
2. Close the appliance door. The programme continues from the point at which it was interrupted.

Cancelling the washing programme

If the washing programme has not yet started, you can change the selection. When a washing programme is in progress, you cannot change the selection. You have to cancel the programme to make a new selection.

Unloading the appliance

- Hot dishes are sensitive to knocks. The dishes should therefore be allowed to cool down before removing from the appliance.
- Empty the lower basket first and then the upper one; this will avoid water dripping from the upper basket onto the dishes in the lower one.

- Water may appear on the sides and the door of the appliance as the stainless steel will eventually become cooler than the dishes.

Maintenance and cleaning

Cleaning the filters

The filters must be checked and cleaned from time to time. Dirty filters will degrade the washing result.

Warning! Before cleaning the filters ensure that the appliance is switched off.

1. Open the appliance door and remove the lower basket.
2. Turn the filter **(A)** anticlockwise and remove it out from filter **(B)**.

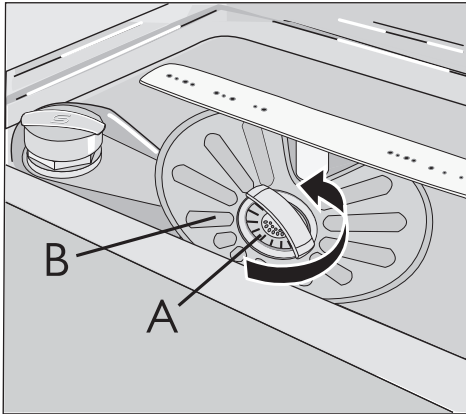

3. Filter **(A)** has two parts. To disassemble the filter, pull them apart.

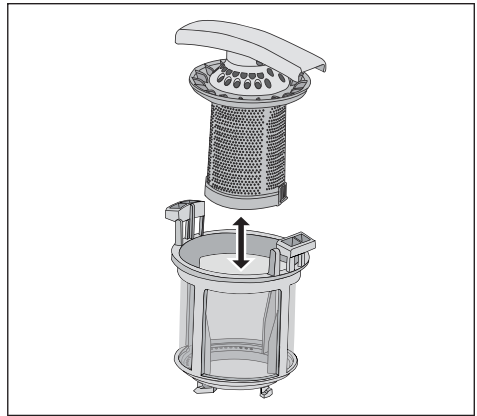

4. Thoroughly clean all parts under running water.
5. Put the two parts of the filter **(A)** together and push. Make sure that they engage correctly in each other.
6. Remove the filter **(B)**.
7. Thoroughly clean filter **(B)** under running water.
8. Put back filter **(B)** in the original position. Make sure that it engages correctly under the two guides **(C)**.

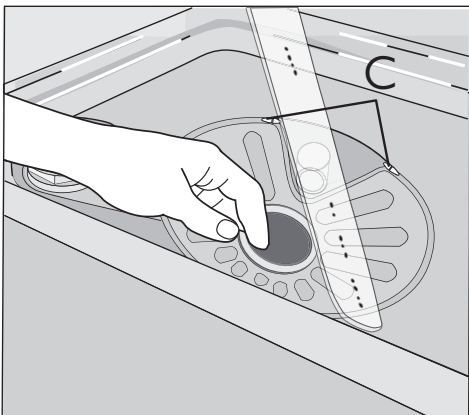

9. Put the filter (A) into position in filter (B). Turn the filter (A) clockwise until it locks.



Caution! Never use the appliance without filters. Incorrect repositioning and fitting of the filters will produce poor washing results and will result in damage to the appliance.

Spray arms



Caution! Never try to remove the upper spray arm.

If residue of soil has clogged the holes in the spray arms, remove the debris with a sharp pointed item (e.g. toothpick, cocktail stick).

Cleaning the appliance

External cleaning

Clean the external surfaces of the appliance and control panel with a damp soft cloth. If necessary use only neutral detergents. Never use abrasive products, scouring pads or solvents, since these can damage the surfaces and plastic parts of the appliance.

Internal cleaning

Ensure that the seals around the door, the detergent and rinse aid dispensers are cleaned regularly with a damp cloth. We recommend every 3 months you run the washing programme for heavy soiled dishes using detergent but without dishes.

Prolonged periods of non-operation

If you are not using the appliance for a prolonged period of time you are advised to:

- Unplug the appliance and then turn off the water.
- Leave the door ajar to prevent the formation of any unpleasant smells.
- Leave the inside of the appliance clean.

Frost precautions

Avoid placing the appliance in a location where the temperature is below 0 °C. If this is unavoidable, empty the appliance, close the door, disconnect the water inlet pipe and empty it.

Moving the appliance

If you have to move the appliance (e.g. moving house):

1. Unplug the appliance.
2. Turn the water tap off.
3. Remove the water inlet and discharge hoses.
4. Pull the appliance out together with the hoses.

Avoid over tilting the appliance during transportation.

Something not working

The appliance does not start or it stops during operation.

Certain problems are due to the lack of simple maintenance or oversights, which can be solved with the help of the indications described in the table, without calling out an engineer.

With some malfunctions, the display shows an alarm code:

- **,10** - The appliance does not fill with water

- **,20** - The appliance does not drain the water
- **,30** - The anti-flood device is on.



Warning! Switch off the appliance before you carry out the following suggested corrective actions.

Malfunction	Possible cause	Possible solution
The appliance does not fill with water.	The water tap is blocked or there is limescale on it.	Clean the water tap.
	The water pressure is too low.	Contact your local Water Authority.
	The water tap is closed.	Open the water tap.
	The filter in the water inlet hose is blocked.	Clean the filter.
	The connection of the water inlet hose is not correct.	Make sure that the connection is correct.
	The water inlet hose is damaged.	Make sure that the water inlet hose has no damages.
The appliance does not drain the water.	There is a blockage in the sink spigot.	Clean the sink spigot.
	The connection of the water drain hose is not correct.	Make sure that the connection is correct.
	The water drain hose is damaged.	Make sure that the water drain hose has no damages.
The anti-flood device is on.		Close the water tap and contact our extended warranty administrators. Refer to 'Repairs - after sales service'.
The start of the washing programme does not occur.	The appliance door is open.	Close the appliance door.

Malfunction	Possible cause	Possible solution
	The mains plug is not connected in the mains socket.	Connect the mains plug.
	The fuse in the fuse box is damaged.	Replace the fuse.
	The delay start is set.	<ul style="list-style-type: none"> • Cancel the delay start. • When the countdown is completed, the washing programme starts automatically.

Once the checks have been carried out, switch on the appliance. The programme continues from the point at which it was interrupted.

If the malfunction occurs again or the display shows an alarm code that is not listed in the table, please contact our extended warranty administrators. Refer to 'Repairs - after sales service'.

The washing and drying results are not satisfactory		
The dishes are not clean.	The washing programme was not applicable for the type of load and soil.	Make sure that the washing programme is applicable for the type of load and soil.
	You did not put the items correctly in the baskets, water did not touch all surfaces.	Put the items correctly in the baskets.
	The spray arms could not turn freely. Incorrect position of the items in the baskets.	Make sure that an incorrect position of the items do not cause the blockage of the spray arms.
	The filters are dirty or not assembled and installed correctly.	Make sure that the filters are clean and correctly assembled and installed.
	The quantity of detergent was not sufficient or missing.	Make sure that the quantity of detergent is sufficient.
Limescale particles on the dishes.	The salt container is empty.	Fill the salt container with dishwasher salt.
	Incorrect level of the water softener adjustment.	Adjust the water softener with the correct level.
	The salt container cap is not closed correctly.	Make sure that the salt container cap is closed correctly.

The washing and drying results are not satisfactory		
There are streaks, whitish stains, or a bluish layer on glasses and dishes.	The rinse aid quantity is too high.	Decrease the rinse aid quantity.
Dry water drop stains on glasses and dishes.	The rinse aid quantity is too low.	Increase the rinse aid quantity.
	The detergent can be the cause.	Use a different brand of detergent.
The dishes are wet.	The washing programme was without a drying phase or with a decreased drying phase.	For better drying results, keep the door ajar for some minutes.
The dishes are wet and matt.	The rinse aid dispenser is empty.	Fill the rinse aid dispenser with rinse aid.
	The Multi tab function is on (this function automatically deactivates the rinse aid dispenser).	Activate the rinse aid dispenser.

Activating the rinse aid dispenser

- Switch off the appliance to confirm the operation.

- Switch on the appliance. The appliance must be in setting mode.
- Press and hold function button **(B)** and function button **(C)** simultaneously until the indicators of function buttons **(A)**, **(B)** and **(C)** start to flash.
- Release function button **(B)** and function button **(C)**.
- Press function button **(B)**, the indicators of function buttons **(A)** and **(C)** go off while the indicator of function button **(B)** continues to flash. The display shows the current setting.

<i>0d</i>	Rinse aid dispenser deactivated
<i>1d</i>	Rinse aid dispenser activated

- Press function button **(B)** again. The display shows the new setting.

Technical data

Dimensions	Width	596 mm
	Height	850 mm
	Depth	597 mm
Water supply pressure	Minimum	0.5 bar (0.05 MPa)
	Maximum	8 bar (0.8 MPa)
Electrical connection	Information on the electrical connection (voltage, overall power and fuse) is given on the rating plate on the inner edge of the appliance door.	
Capacity	Place settings	12



Installation



Warning! It is dangerous to alter the specifications or attempt to modify the appliance in any way.



Warning! This appliance is heavy. Care should be taken when moving it.



Warning! Care must be taken to ensure that the appliance does not stand on the electrical supply cable.



Warning! Any electrical or plumbing work required to install this appliance must be carried out by a qualified electrician or plumber.

- Position the appliance next to a water tap and a drain.

Fitting under the kitchen worktop

By removing the worktop of the appliance, you can install it under the kitchen worktop or a close fitting sink. The dimensions of the recess must correspond to those shown in the picture.

Unpacking

- Remove all packaging before positioning the appliance.

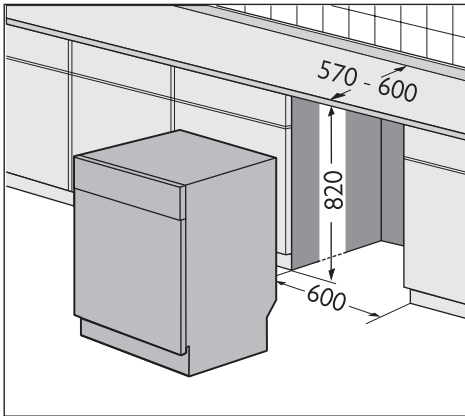

Removing the appliance worktop

1. Remove the appliance worktop by unscrewing the two rear retaining screws (1)

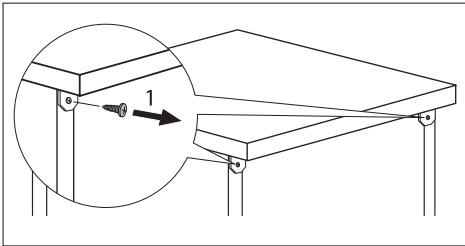

2. Pull the worktop from the back of the appliance (2).

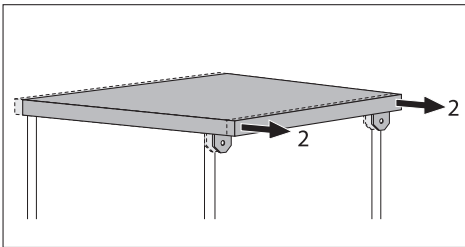

3. Lift the worktop (3) and slide it out of the front slots.

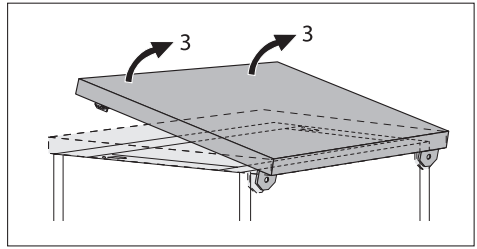

Insert the appliance once the levelling has been done.

When inserting the appliance, ensure that the water inlet and drain hoses are not kinked or squashed.

During all operations that involve accessibility to internal components the appliance must be unplugged. Be sure that once the appliance has been installed, it is easily accessible for the service engineer in the event that a repair is required.

If the appliance is later used as a freestanding appliance, the original worktop must be reassembled.

The plinth on freestanding appliances is not adjustable.



Caution! It is necessary to protect the underside of the kitchen worktop from condensation. A plastic top cover can be purchased, contact your local John Lewis branch.

Levelling of the appliance

Good levelling is essential for correct closure and sealing of the appliance door.

When the appliance is correctly levelled, the door will not catch on either side of the cabinet.

If the appliance door does not close correctly, loosen or tighten the adjustable feet until the level of the appliance is perfect.

Water connection

Water inlet connection

This appliance may be fed with either hot (maximum 60 °C) or cold water.

Nevertheless we advise you use a cold water supply. A hot water supply is not always efficient with heavily soiled crockery as it shortens the washing programmes a lot. For making the connection itself, the coupling nut fitted to the appliance inlet hose is designed to screw onto a 3/4" gas thread spout or to a purpose made quick-coupling tap such as the Press-block.

The water pressure must be within the limits given in the 'Technical data'. Your local Water Authority will advise you on the average mains pressure in your area.

The water inlet hose must not be kinked, crushed, or entangled when it is being connected.

The appliance features inlet and drain hoses which can be turned either to the left or the right to suit the installation by means of the locknut. The locknut must be correctly fitted to avoid water leaks.

If the appliance is connected to new pipes or pipes which have not been used for a long time, you should run the water for a few minutes before connecting the inlet hose.

This appliance has been fitted with safety features which will prevent the water used in the appliance from returning back into the drinking water system. This appliance complies with the applicable plumbing regulations.



Caution! Do not use inlet and drain hoses which have previously been used on another appliance.

Water drain connection

The end of the drain hose can be connected in the following ways:

- To the sink outlet spigot, securing it to the underside of the work surface. This will prevent waste water from the sink running into the appliance.
- To a stand pipe provided with venthole, minimum internal diameter 4 cm.

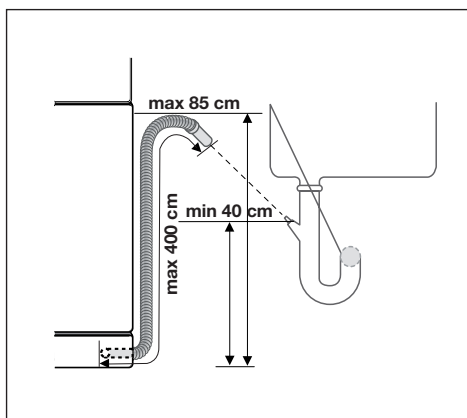

The drain hose can face either to the right or left of the appliance.

Ensure the drain hose is not bent or squashed as this could prevent or slow down the discharge of water.

The sink plug must not be in place when the appliance is draining as this could cause the water to syphon back into the appliance.

If you use a drain hose extension, the internal diameter must be no smaller than the diameter of the hose provided.

Likewise the internal diameter of the couplings used for connections to the waste outlet must be no smaller than the diameter of the hose provided.

Our appliances are supplied with a security device to protect against the return of dirty water back into the appliance. If the spigot of your sink has a "no return valve" incorporated this can prevent the correct draining of your appliance. We therefore advise you to remove it.

When connecting the drain hose to an under sink trap spigot, the entire plastic membrane (A) must be removed. Failure to remove all the membrane will result in food particles building up over time eventually blocking the appliance drain hose spigot.

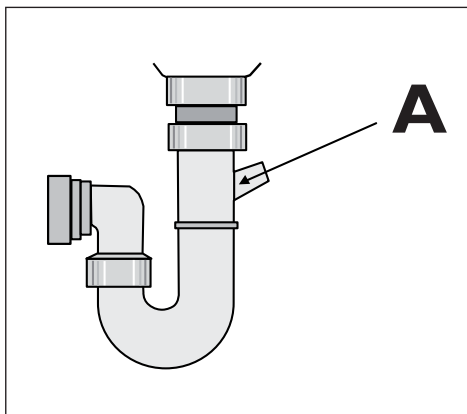

Electrical connection

The manufacturer accepts no liability for failure to observe the following safety precautions.



Warning! Safety standards require the appliance to be earthed. Prior to using the appliance for the first time, ensure that the rated voltage and type of supply on the rating plate match that of the supply where the appliance is to be installed. The fuse rating is also to be found on the rating plate.

Always plug the mains plug into a correctly installed shockproof socket. Multi-way plugs, connectors and extension cables must not be used. This could constitute a fire hazard through overheating.

If necessary, have the domestic wiring system socket replaced. In case that the electrical cable has to be replaced, contact your local repair agent.

The plug must be accessible after the appliance has been installed. Never unplug the appliance by pulling on the cable. Always pull the plug. The appliance is supplied with a 13 amp plug attached. Use a 13 amp ASTA approved (BS 1362) fuse if it is necessary to change the fuse in the plug supplied.

Repairs - after sales service

Your appliance comes with a three year warranty. If it is not working correctly refer to "Something not working". If a fault occurs which you can not resolve through following the advice and information contained within this instruction manual, the next step is to contact our extended warranty administrators on:

0844 871 7771

They will give you details for your local service engineer. Before calling out an engineer, please ensure you have read the details under the heading "Something not working".

When you contact your local service engineer you will need to give the following details:

1. Your name, address and post code
2. Your telephone number
3. Clear and concise details of fault
4. The purchase date as found on your receipt
5. The model and serial number of the appliance. So that you always have these numbers at hand, we recommend you to make a note of them here:

- Mod.....
- P.N.C.....
- S.N.....

IMPORTANT : If you call out an engineer to a fault listed under the heading "Something not working", or to repair a fault caused by incorrect use or installation, a charge will be

made even if the appliance is under guarantee.

Spare parts

Always insist on genuine spare parts.

An authorised service engineer should service this product, and only genuine spare parts should be used. Under no circumstances should you attempt to repair the appliance yourself. Repairs carried out by inexperienced persons may cause injury or serious malfunctioning. Contact your local John Lewis branch.

John Lewis Partnership

171 Victoria Street
London SW1E 5NN
www.johnlewis.com

Free Manuals Download Website

<http://myh66.com>

<http://usermanuals.us>

<http://www.somanuals.com>

<http://www.4manuals.cc>

<http://www.manual-lib.com>

<http://www.404manual.com>

<http://www.luxmanual.com>

<http://aubethermostatmanual.com>

Golf course search by state

<http://golfingnear.com>

Email search by domain

<http://emailbydomain.com>

Auto manuals search

<http://auto.somanuals.com>

TV manuals search

<http://tv.somanuals.com>