

JLBIOS610

Built-in oven

Instruction manual

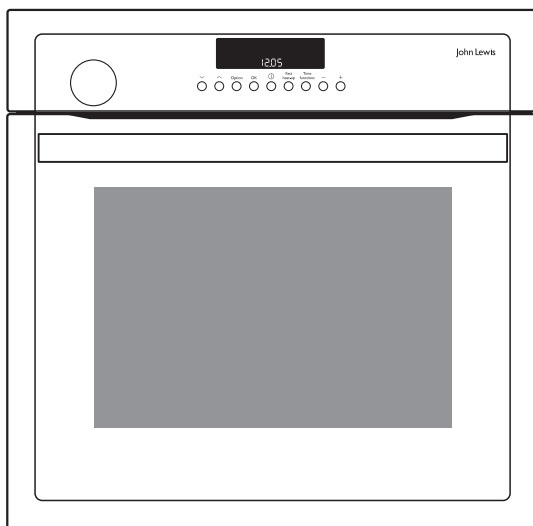

John Lewis

Safety instructions

It is most important that this instruction book should be retained with the appliance for future reference. Should the appliance be sold or transferred to another owner, or should you move house and leave the appliance, always ensure that the book is supplied with the appliance in order that the new owner can get to know the functioning of the appliance and the relevant warnings.

These warnings have been provided in the interest of safety. You **MUST** read them carefully before installing or using the appliance. If you are unsure of the meanings of these warnings contact the John Lewis branch from which you purchased the appliance.

Electrical safety

- This appliance must be only connected by a **registered electrician**.
 - In the event of a fault or damage to the appliance: Take the fuses out or switch off.
 - **Repairs** to the appliance must only be carried out by **qualified service engineers**. Considerable danger may result from improper repairs. If repairs become necessary, please contact our Customer Services or your dealer.
- supervision or instruction by a responsible person.
 - This appliance is intended to be used for cooking, roasting and baking food in the home.
 - Be careful if connecting electrical appliances to sockets near this appliance. Electrical leads should **not** be allowed to come near the hotplates or to become caught under the hot oven door.

Child safety

- This appliance is designed to be operated by adults. Do not allow children to play with or near the oven.
- The appliance is fitted with a child safety device.

During use

- People (including children) who, because of their physical, sensory or mental capabilities or their inexperience or ignorance are not able to use the device safely, should not use this device without
-
- If you use alcohol in your cooking, a slightly flammable alcohol/air mixture may ensue. In this case, be careful when opening the door. Do not handle any



Warning! Danger of burns!

When in use, the oven interior surfaces become very hot.



Warning! When cooking with the Vigorous Steam function, do not under any circumstances open the oven door.

The escaping steam can cause moisture damage to furniture and cabinets. Avoid any direct contact with escaping steam.

sources of heat, sparks or naked flames when doing so.

Information on acrylamides



According to the latest scientific knowledge, intensive browning of food, especially in products containing starch, can constitute a health risk due to acrylamides. Therefore we recommend cooking at the lowest possible temperatures and not browning foods too much.

How to avoid damage to the appliance

- Do not line the oven with aluminium foil and do not place baking trays, pots, etc. on the oven floor, as the heat that builds up will damage the oven enamel.
- Fruit juices dripping from the baking tray will leave permanent stains. For very moist cakes, use a deep tray.

- Do not put any strain on the oven door when open.
- Never pour water directly into the oven when it is hot. This could cause damage to or discolouration of the enamel.
- Rough handling, especially around the edges of the front panel, can cause the glass to break.
- Do not store flammable materials inside the oven. These could ignite when the oven is switched on.
- Do not store moist foods inside the oven. This could damage the oven enamel.

Note on enamel coating



Changes in the colour of the oven's enamel coating as a result of use do not affect the appliance's suitability for normal and correct use. They therefore do not constitute a defect in the sense of the warranty law.

Contents

For the user

Safety instructions 2

Description of the appliance 5

General overview 5

The electronic oven controls 6

Oven features 7

Oven accessories 7

Before using for the first time 8

Setting the clock 8

Using the oven 9

Using your appliance 9

Heat indicator 9

Inserting the oven shelf, baking tray and roasting pan 10

Steam cooking functions 11

Meat probe 12

Automatic programmes 14

Options 17

Clock functions 21

Cleaning and care 23

Something not working 29

Disposal 30

Packaging material 30

Old appliance 30

For the installer

Electrical connections 31

Installation instructions 32

Technical data 38

Guide to use the instruction manual

The following symbols will be found in the text to guide you throughout the instructions:



Safety instructions



Hints and tips



Environmental information

Description of the appliance

General overview

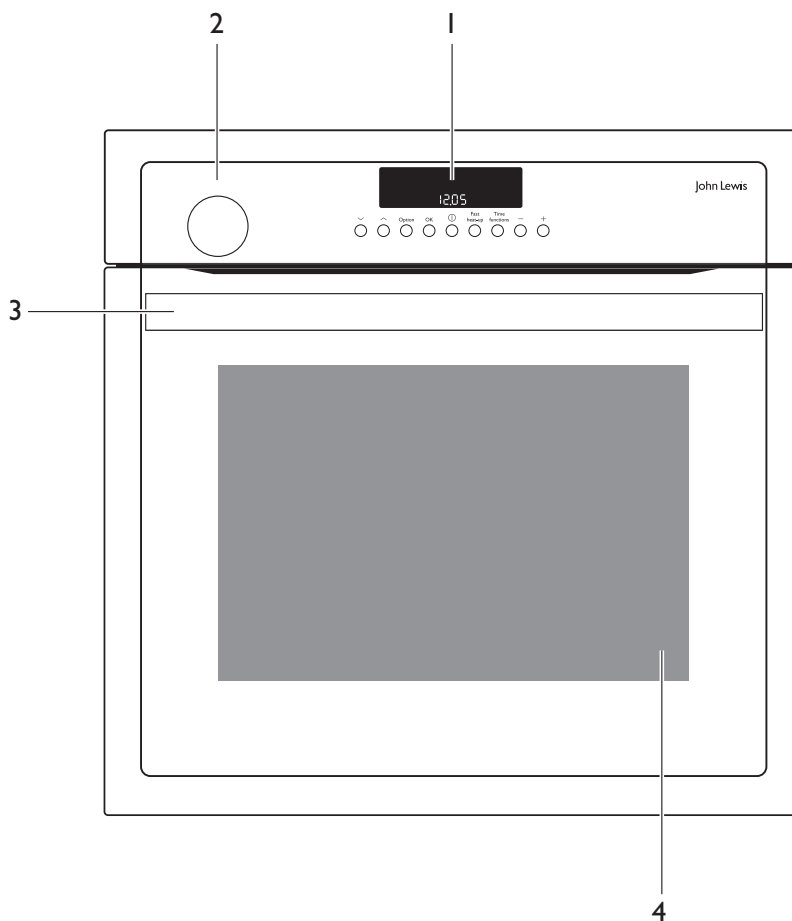

1. Oven displays and buttons

2. Water drawer

3. Door handle

4. Full glass door

The electronic oven controls

Indicators

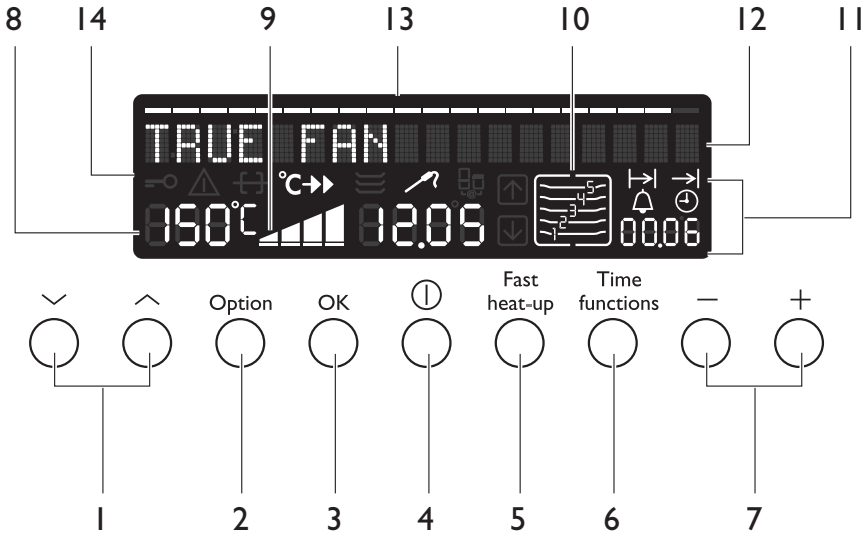

1. Up and Down arrows, to select oven functions and to navigate in the menus
2. Options menu
3. Ok-button, to confirm or change to the submenu
4. On/Off button, to switch the appliance on or off
5. Fast Heat Up
6. Time or Meatprobe functions
7. Increase/decrease settings button
8. Temperature Indicator
9. Heat indicator
10. Shelf position
11. Period of operation
12. Text line
13. Menu status bar

14. Symbol status bar

Symbol status bar

Symbol	Function
	RAPID HEAT UP is in operation.
	MEATPROBE is plugged in.

Menu status bar

In the menu status bar the current position within a menu is shown by a flashing bar. When the menu status bar can no longer be seen in the display, the oven begins to heat or the time set begins to count down.

Oven features

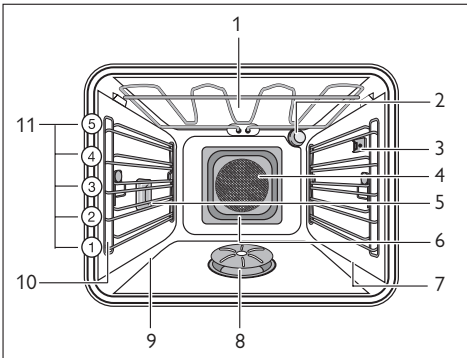

1. Top heat and heating elements
2. Oven lighting
3. Meat probe socket
4. Fan
5. Oven lighting
6. Rear wall heating element
7. Oven shelf runners, removable
8. Steam generator/ Steam rosette
9. Bottom Heat
10. Oven shelf runners, removable
11. Shelf positions

Oven accessories

Oven shelf

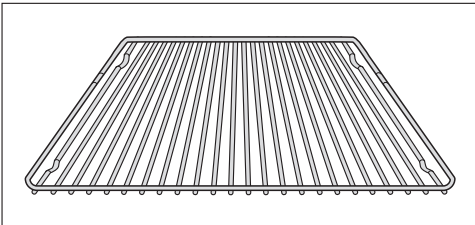

For dishes, cake tins and items for roasting and grilling.

Baking tray

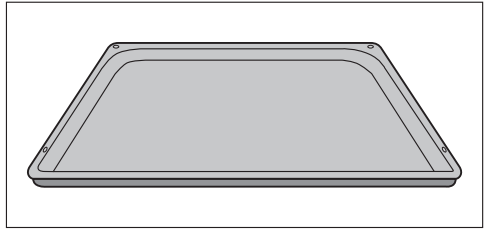

For cakes and biscuits (not suitable for VIGOROUS STEAM cooking).

Roasting pan

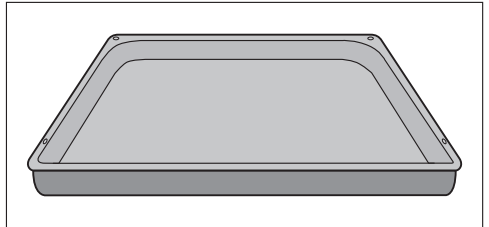

For baking and roasting or for collecting fat (not suitable for VIGOROUS STEAM cooking).

Meat probe

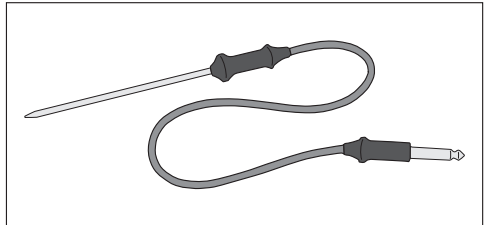

Used on joints of meat to determine exactly how well done they are during cooking (not suitable for Vigorous Steam cooking)
Unperforated and perforated food container.

Filter insert

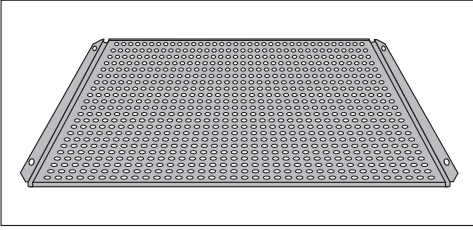

For insertion in the roasting pan. So that the roast does not lie in its own juice and as a splash guard.

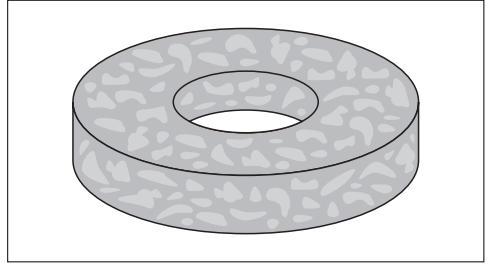

QuickSponge 180



Extremely absorbent sponge for absorbing any residual water from the steam generator.



Before using for the first time

Setting the language

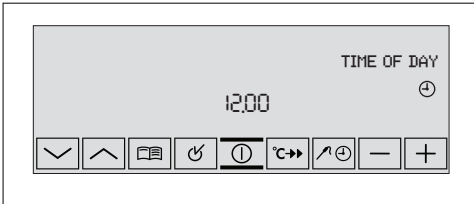
1. When the appliance has been connected to the electrical supply, SPRACHE EINSTELLEN - LANGUAGE MENU is shown in the display.
2. Using the arrow buttons  or  select the desired language.
3. Confirm selected language with the OK  button. From now on the texts in the display appear in the language set.



Setting the clock

1. TIME OF DAY lights up. In the clock display you see 12.00.
2. Using the  or  button, set the current time.

3. Confirm using the SELECTION  button. The appliance switches itself off and is now ready for use.

 If you would like to change one of these base settings at a later date, please refer to the chapter SETTINGS MENU.

Initial cleaning

Clean the oven before using it for the first time.

Important! Do not use caustic or abrasive cleaning agents! These can damage the oven surfaces.

 For the metal surfaces, use commercially available cleaning agents.

1. Open the oven door. The oven light is lit.
2. Remove all oven accessories, and clean them with warm water and a scouring agent.

3. Wash the oven in the same way, and wipe dry.

4. Wipe the front of the appliance with a damp cloth.

Using the oven

Using your appliance

Examples of use

Here are three examples of use to explain the various functions of the unit:

Toast using the grill oven function

You want to make a quick toast

1. Switch the appliance on with.
The menu OVEN FUNCTIONS appears.
2. Select the oven function using GRILL.
3. Set temperature to 280 °C using - .
4. Reduce the heating time by selecting fast heat.

The oven starts to heat up and the heating indicator is active. As soon as 280 °C has been reached, an audible signal can be heard and the heating indicator shows full heat.

5. Place the toast on the highest slide-in level.

Chicken (meat programme with automatic weighing device)

You want to roast a 1.5 kg chicken for guests.

1. Select OVEN FUNCTION POULTRY from the menu.
The weight setting flashes.
2. Set weight to 1.5 kg.

 The weight can only be adjusted in 0.2 kg stages.

The oven starts to heat up. Temperature and duration are indicated and the heating indicator flashes.

The chicken is almost ready when your guests call to say that they have been delayed.

With HEAT & HOLD, the chicken can be kept warm for 30 minutes after it is cooked.

3. Press the button repeatedly until HEAT & HOLD flashes.
4. Set to + 30 minutes and confirm with OK button.

Lemon cake (automatic recipes)

You want to bake a lemon cake from the recipe booklet.

- Select the options RECIPES MENU, RECIPES BAKING, LEMON SPONGE CAKE from the menu.

The oven starts to heat up. Temperature and duration are indicated and the heating indicator flashes.

All settings are fixed and cannot be changed.

Cooling fan

The fan switches on automatically in order to keep the appliance's surfaces cool. When the oven is switched off, the fan continues to run to cool the appliance down, then switches itself off automatically.

Heat indicator

Heating Up indicator

When the oven function has been **switched on**, the bars that slowly light up one after the other indicate how far the oven has heated up.

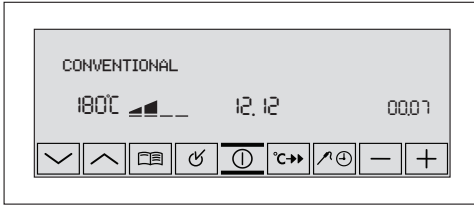

Rapid Heat Up indicator

When the RAPID HEAT UP function has been switched on, the bars that flash one after the other indicate that RAPID HEAT UP is operating.

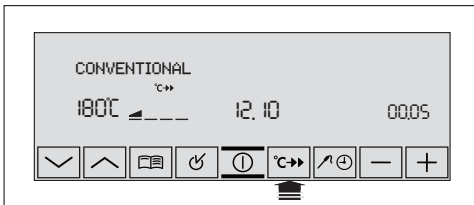

Residual heat indicator

After **switching off** the oven, the residual heat in the oven is displayed.

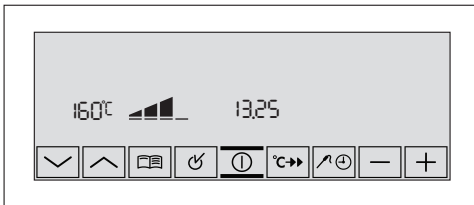

Checking the temperature to the degree

Press the \oplus and \ominus buttons at the same time. The current oven temperature is displayed.



Inserting the oven shelf, baking tray and roasting pan

Shelf runner safety and anti-tip device



As a shelf runner safety device, all insertable components have a small curved indentation at the bottom on the right and left-hand edge. Always insert insertable components so that this indentation is at the back of the oven interior. This indentation is also important for preventing the insertable components from tipping.

Inserting the baking tray or roasting pan

Push the baking tray or roasting pan between the guide bars of the selected oven level.

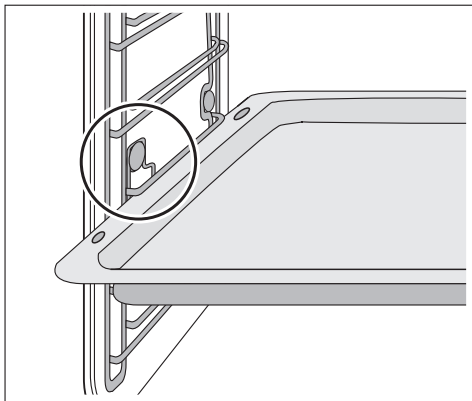

Inserting the oven shelf:

Insert the oven shelf so that the feet point downwards.



Push the oven shelf between the guide bars of the desired oven level.

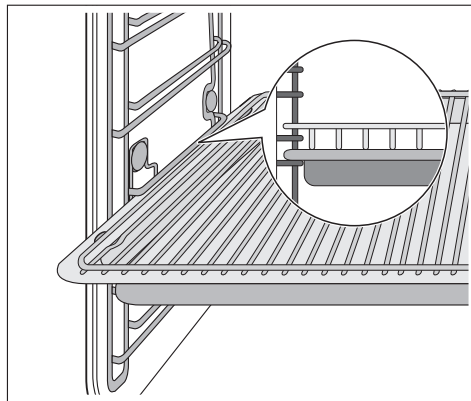

The high rim around the oven shelf is an additional device to prevent cookware from slipping.



Steam cooking functions

Important! The Steam Cooking functions must always be set in conjunction with the clock functions DURATION  or END .

Important! Always use water only. A buzzing sound is heard when the water has been used up. When more water is added, the buzzing sound is switched off.



Because of the automatic steam dispersal period of approx. 5 minutes at the end of the cooking time and the heating up time of approx. 2 minutes, settings of less than 10 minutes have little effect. Steam will also escape when the door is opened.

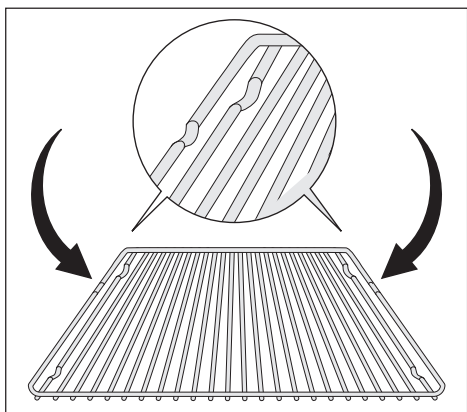

Inserting the oven shelf and roasting pan together

Lay the oven shelf on the roasting pan. Push the roasting pan **between** the guide bars of the selected oven level.

VIGOROUS STEAM

1. The water (650 ml) is not poured directly into the steam generator, but **into the water drawer** in the control panel. The water supply lasts for approx. 30 minutes.

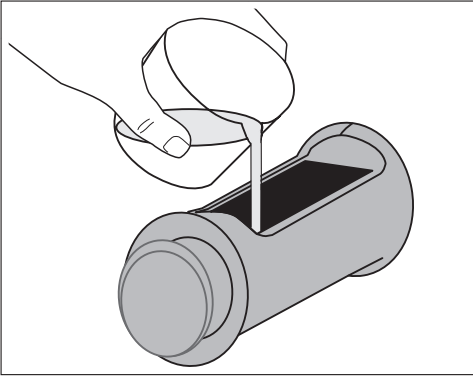

2. Select the oven function VIGOROUS STEAM and select the desired temperature.
3. Select the function DURATION [H] or END [H] and set the desired cooking time or switch-off time. After about 2 minutes, the first steam appears. An audible signal indicates when the cooking temperature of around 96°C is reached. Another signal indicates the end of cooking time.
4. After the oven has cooled down, soak up any remaining water from the steam generator using a sponge and, if necessary, wipe out with a little vinegar. Leave the door open to let the oven dry completely.

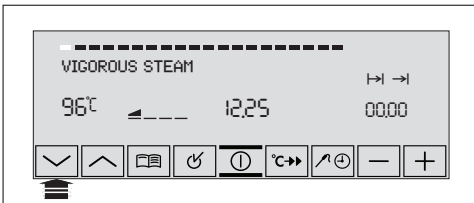

INTERVAL PLUS and INTERVAL STEAM

The continual change from fan to steam takes place automatically, with INTERVAL PLUS however with a greater percentage of steam.

1. Do not pour water directly into the steam generator, but **into the drawer** in the control panel.
2. Select the oven function INTERVAL PLUS or INTERVAL STEAM and select the desired temperature.
3. Select the function DURATION or END set the desired cooking time or switch-off time. Then proceed as for VIGOROUS STEAM.

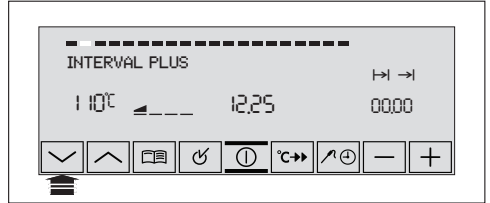

Meat probe



When the meat probe is plugged in, the OVEN FUNCTIONS menu offers a choice of suitable oven functions and additional programmes for the meat probe.

Important! Only the meat probe supplied may be used. If replacing, please use only original replacement parts.

Inserting the meat probe

1. Switch on the appliance.
2. Push the tip of the meat probe into the meat as fully as possible, so that the tip is in the centre of the meat.
3. Insert the meat probe plug into the socket on the side wall of the oven as far as it will go.

Now there are two options to cook the meat with the meat probe:

1. Setting meat probe core temperature

For switching off the oven when the temperature at the centre of a roast reaches the exact temperature set by you.

There are two temperatures to consider:

- The oven temperature: see Roasting Table
- The core temperature: see Meat Probe Table

1. Insert meat probe as described before. MEATPROBE is displayed in the text line and the symbol lights up.

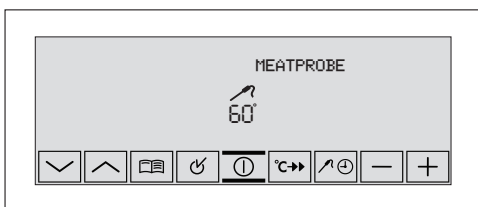

2. Within 5 seconds use \uparrow or \downarrow to set the desired core temperature. The display changes to the current core temperature.

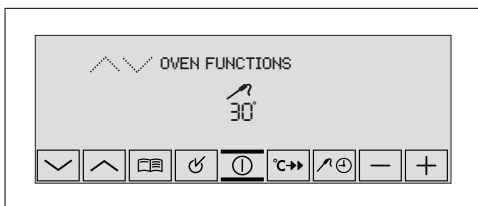

- i** If OVEN FUNCTIONS is already displayed in the text line, before the desired core temperature has been set, then press the SELECTION button, until the symbol flashes and then perform the setting.

- i** The core temperature is displayed from 30°C.

3. Set the oven function and, if necessary, the oven temperature.



A provisional end time will be calculated depending on the quantity of food and the selected oven temperature (at least 120°C) and operating mode. This procedure can amount to approx. 30 minutes and is updated in the display during the cooking process. For the system to work, it is essential that the meat probe is in the meat and in the socket at the start of the cooking process and that it is not removed during the cooking process.

During the calculation phase, the display for the time of day and meat's core temperature shows a "flashing square". As soon as the pre-set core temperature is reached, a signal sounds and the appliance switches itself off automatically.

4. Press any button to switch off the signal.

Changing the core temperature at a later time:

Press the SELECTION button repeatedly until the MEATPROBE function flashes and the core temperature set appears in the temperature display. Then change the temperature using the \uparrow or \downarrow button.

2. Use the Automatic programmes with the meat probe

1. Switch on the appliance.
2. Insert meat probe. In the text line MEATPROBE is displayed and the symbol flashes.

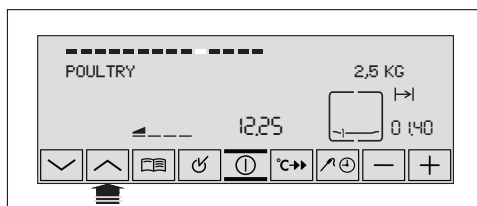

- Using the arrow buttons to select the desired MEATPROBE programme.
As soon as the pre-set core temperature is reached, a signal sounds and the temperature reached flashes.

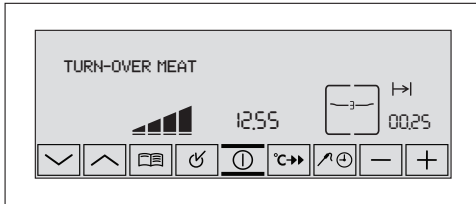

- To switch off the signal, press any Button.

Removing the meat probe



Warning! The meat probe is very hot. There is a risk of being burned when removing

- Switch off the appliance.
- Remove the meat probe's plug from the socket and take the meat out of the oven.

Automatic programmes

Automatic programmes

In addition to the oven functions for individually setting baking and roasting, you have the option of working with various automatic programmes:

- Meat programmes with weight input (OVEN FUNCTIONS menu)
- Meat programmes with meat probe (OVEN FUNCTIONS menu)
- Automatic recipes (Options menu)

1. Meat programmes with weight input

The meat programmes offer optimum settings for each type of meat. The roasting time is automatically determined by inputting the weight of the meat.

To change the weight use the arrow buttons.

You can also set the starting or the ending time.

If the POULTRY meat programme is chosen, please turn the food if an acoustic signal sounds and the instruction TURN-OVER MEAT is in the text line.

When all meat programmes are completed, an audible signal sounds.

2. Meat programmes with meat probe (see chapter "Meat probe")

3. Automatic recipes

Recipe MENU in overview

The menu "Automatic Recipes" is divided into 4 categories.

- Steam recipes (recipes like reheating, fresh vegetables...)
- Baking recipes (recipes like lemon sponge cake, Swedish cake.....)
- Roasting recipes (recipes like pizza, onion tare.....)
- Other recipes (recipes like powder cake, frozen pizza...)

To switch between these 4 use the arrow buttons and confirm with the  BUTTON
To choose one recipe in one of those 4 use the arrow buttons.









For the categories STEAM RECIPES, BAKING RECIPES and ROASTING RECIPES use the recipe suggestions in the booklet "Tables, Tips and Recipes" This function offers optimum settings for each recipe.

STEAM RECIPES, BAKING RECIPES and ROASTING RECIPES



For STEAM RECIPES: Pour the amount of water given in the recipe **into the water drawer.**

Selecting a recipe

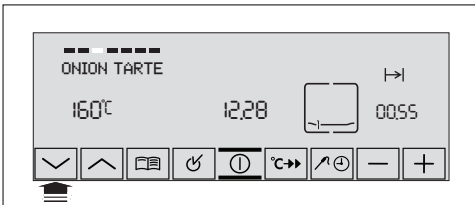

1. Using the OPTION  button, change to the Options menu.
2. Use the OK  button to change to the RECIPE MENU menu.
3. Use the arrow buttons  or  to select the desired recipe category.
4. Use the OK  button to change to e.g. the ROASTING RECIPES menu.
5. Use the arrow buttons  or  to select the desired recipe. If the selection is not altered for a few seconds, the oven takes this setting and begins to heat up.





6. An audible signal will sound when the cooking time has finished.
 - “00:00:” flashes in the clock display and the symbol  flashes.
 - The oven heating switches itself off.
7. The audible signal can be stopped by pressing any button.

Delaying the start time





Running the programme can also be automatically started at a later time (see Clock Functions END ).

-  The clock function END  can be set, if the programme has been running for less than two minutes.



Ending the cooking time early

Press and hold the OPTION  button or using the arrow buttons  or  select the menu option BACK.

OTHER RECIPES

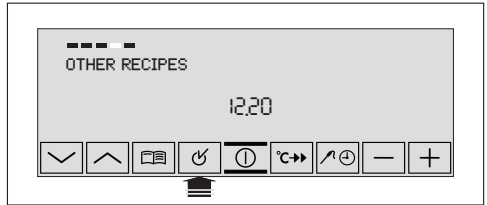
1. Using the OPTION  button, change to the Options menu
2. Use the OK  button to change to the RECIPE MENU menu.
3. Using the arrow buttons  or  select the recipe category OTHER RECIPES.
4. Use the OK  button to change to the OTHER RECIPES menu.





5. Using the arrow buttons  or  select the desired menu option.

A suggested temperature appears in the display.

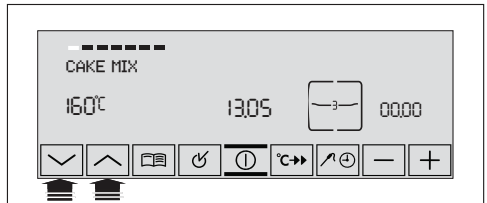
If the selection is not altered for a few seconds, the oven takes this setting and begins to heat up.



-  With the recipes CAKE MIX and FROZEN PIZZA using the  or  buttons, the suggested temperature can be increased or decreased by 10°C.

In the category OTHER RECIPES you will find the following menu options:

CAKE MIX	For baking ready-made cakes and cake mixes.
FROZEN PIZZA	For baking ready-made meals such as pizza, lasagne, gratins and chips from the deep freeze.
DRYING HERBS	For drying fruit, herbs and mushrooms.





You will find further instructions on these functions in the booklet “Tables, Tips and Recipes”.

MEMORY MENU

With this function you can save the optimum settings for your own recipes. The first three “Personal Recipes” can be called up again directly in the Oven Functions menu. There are 10 memory positions available for recipes and 10 for recipes with preset meat probe core temperatures.

Saving settings for “Personal Recipes”

To save settings for a known recipe

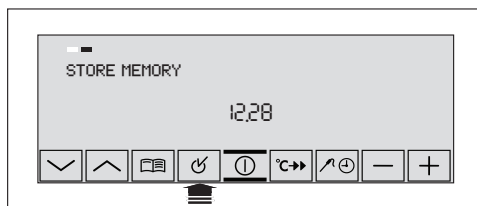

1. Select oven function and temperature.
2. If necessary, use the SELECTION  button to change to the clock function DURATION  and input the desired cooking time (see “Clock Functions” section)
or
 use the SELECTION  button to change to the MEATPROBE function and input the desired core temperature (see “MEATPROBE” section).
3. Using the OPTION  button, change to the Options menu.

4. Using the OK  button, select the suggested menu option STORE MEMORY.
 The next free memory position is displayed.





5. Use the OK  button, to select e. g. MEMORY 1.
 The first letter in the text line will flash.

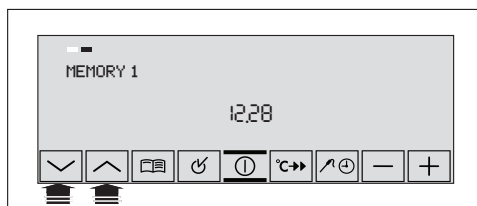

6. Using the arrow buttons  or , select the desired letter from the alphabet.



7. Use the  or  button to move the dash to the right or left.
 The next letter will flash and can be changed, and so on.
 In this way you can write the name of your “Personal Recipe”.

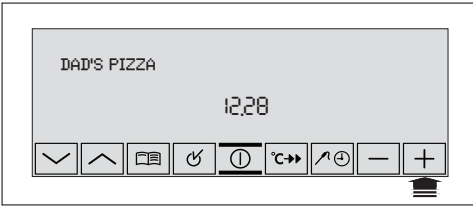

i You can call up the first three saved “Personal Recipes” directly in the Oven Functions menu. Further “Personal Recipes” can be called up in the MEMORY MENU under the menu option START MEMORY.

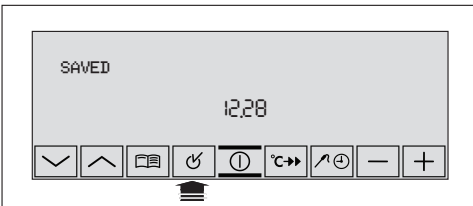

i There are 18 input fields available.

When you have finished writing the name, press and hold the OK  button. **SAVED** is shown.



i The settings can also be shown during or at the end of a baking/roasting process.

Calling up settings for your own “Personal Recipes”

1. Switch on the appliance using the ON/OFF  button.
2. Using the arrow button , select the saved recipe.

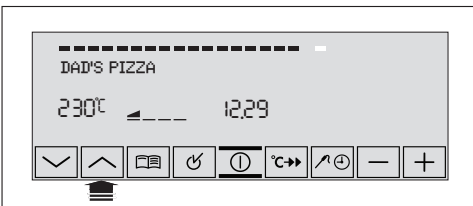

Overwriting a memory position

Memory positions that are already filled can be overwritten at any time. To do this, proceed as explained in the “Saving settings for your own recipes”. However at point 5, instead of the suggested free memory position, use the  button to select the recipe that you want to overwrite.

Options

SETTINGS MENU

i Independent of the current use of the oven, you can change various base settings. These remain permanently set, until they are changed again.

HEAT+HOLD MENU











– HEAT+HOLD ON	The HEAT+HOLD function is offered in the menu list after a DURATION or END is completed and can be activated.
– HEAT+HOLD OFF	The HEAT+HOLD function is not offered in the menu list.

EXTRA TIME MENU

– EXTRA TIME ON	The TIME EXTENSION function is offered when a DURATION was set and has elapsed.
-----------------	---

– EXTRA TIME OFF	The TIME EXTENSION function is not offered.
RAPID HEAT UP MENU	
– RAPID HEAT UP ON	The RAPID HEAT UP MENU function is automatically switched on with suitable oven functions.
– RAPID HEAT UP OFF	The RAPID HEAT UP MENU function is not automatically switched on with suitable oven functions.
RESIDUAL HEAT MENU	
– INDICATOR ON	After the appliance is switched off, the residual heat is automatically indicated.
– INDICATOR OFF	After the appliance is switched off, the residual heat is not indicated.
SOUND MENU	
– BUTTON TONE MENU – TONE ON – TONE OFF	For setting if each press of a button is to be confirmed with a tone.
– ERROR TONE MENU – TONE ON – TONE OFF	For setting if audible signals for operational steps that cannot be carried out are to be acknowledged with a tone.
LANGUAGE MENU	
– ENGLISH – ...	For setting the language in the display.
FACTORY SETTINGS	
– RESTORE SETTINGS	For restoring all settings to the status as at the time of delivery.

Adjusting SETTINGS MENU

- Using the OPTION  button, open the Options menu.
- Using the arrow buttons  or  select the menu option SETTINGS MENU.
- Using the OK  button, change to the SETTINGS MENU menu.
- Using the arrow buttons  or  go to the setting that you want to adjust.
- Press the OK  button.
The value currently set appears in the display.
- Using the arrow buttons  or  select the desired value.
- Press the OK  button.
In the display SAVED appears for a few seconds.
Afterwards, you will find yourself back in the Oven Functions menu.

Everyday use of the SETTINGS MENU



Heat+Hold

The Heat+Hold function keeps your prepared dish warm for 30 minutes, after the baking or roasting process is completed. This is helpful, for example, if your guests are late.

Pre-condition for Heat+Hold:

- Set temperature is above 80°C
- Fixed duration

Switching on Heat+Hold

- Select oven function, meat programme or automatic programme.
- If necessary, set duration or core temperature.
- Press the SELECTION  button repeatedly until HEAT+HOLD flashes.
- Confirm with .
The Heat+Hold function is now switched on.

5. As soon as the function is completed, a signal sounds and Heat+Hold starts. The function set runs at 80°C for 30 minutes. After 30 minutes with Heat+Hold are over, the oven switches itself off.

i Irrespective of the function set, Heat+Hold remains active. You can change between the oven functions.

i Heat+Hold can be activated or deactivated in the SETTINGS MENU menu.

EXTRA TIME MENU

Allows the last oven function to continue to run after the time has elapsed. Pre-condition:





- All oven functions with DURATION or Auto Weight.
- No oven functions with MEATPROBE.

The EXTRA TIME MENU can be switched on and off in the SETTINGS MENU menu.

Switching on EXTRA TIME MENU

Oven function is completed.

Signal sounds and message appears.

1. Press any button (except ON/OFF .
2. Message for EXTRA TIME MENU appears for approx. 3 minutes.
3. Activate with  EXTRA TIME MENU.
4. Set duration of the EXTRA TIME MENU using  or .
5. Start EXTRA TIME MENU using or  let it start automatically after 5 seconds.



The settings of the oven function are displayed with the new duration.

i The rest of the procedure is the same as for a normal oven function. The EXTRA TIME MENU can be set repeatedly.

Pre-heating with the RAPID HEAT UP function

After an oven function has been selected, with the additional function RAPID HEAT UP the pre-heating time can be shortened. Pre-heating the empty oven is unnecessary for most baking and roasting sessions, because the temperature set is generally reached in a short time (see Tables and Tips). We recommend pre-heating the empty oven using the RAPID HEAT UP function for biscuits that quickly spread into one another, bread rolls and Swiss rolls.

Important! Important: Do not put the food to be cooked into the oven, **until** RAPID HEAT UP **is completed** and the oven is operating using the desired function.

1. Set the oven function (e.g. CONVENTIONAL). Change the suggested temperature, if necessary.
2. Press the RAPID HEAT UP  button. The symbol  lights up: When the bars flash one after another it shows that RAPID HEAT UP is operating. When the temperature set is reached, the bars of the heat indicator are lit. An audible signal sounds. The symbol  goes out. The oven now continues heating according to the pre-set oven function and temperature. You can now place the food in the oven.

i If you generally prefer to put food into a pre-heated oven, you can switch on the RAPID HEAT UP function permanently (see SETTINGS MENU). The RAPID HEAT UP function is then switched off with the RAPID HEAT UP  button.



The RAPID HEAT UP function can be switched on with the oven functions TRUE FAN, FAN BAKING, CONVENTIONAL and ROTITHERM.

Clock functions

Information about the clock functions

After a clock function has been selected, the corresponding symbol flashes for about 5 seconds. During this time, the desired times can be set or modified using the or button. When the desired time has been set, the corresponding symbol continues to flash for approx. 5 seconds. After this the symbol illuminates. The set time begins to run.



Using residual heat with the DURATION and END clock functions

When the DURATION and END clock functions are used, the oven switches the heating elements off, when 90% of the time set or calculated has elapsed. The residual heat present is used to continue the cooking process until the time set has elapsed (3 to 20 mins.).



The clock functions display shows the **period of operation for the selected oven function**, if none of the clock functions MINUTE MINDER, DURATION or END is set.



To turn off the audible signal: Press any button.

MINUTE MINDER

To set a countdown. A signal sounds after the time has elapsed. This function does not affect the functioning of the oven.

1. Press the SELECTION button repeatedly, until MINUTE MINDER and the symbol is displayed.

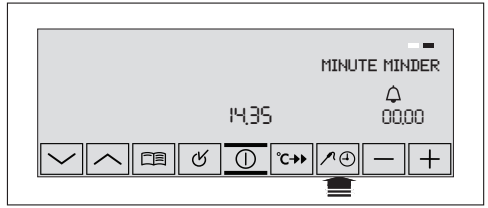

2. Using the or button, set the desired Countdown time (max. 99 minutes). After about 5 seconds the display shows the time remaining. OVEN FUNCTIONS and the symbol are shown in the display.

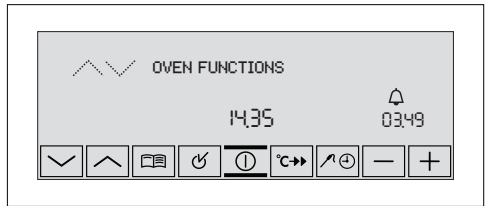

When the time has elapsed, an audible signal sounds for 2 minutes. "00.00" and the symbol flash.



DURATION

To set how long the oven is to be in use.

1. Select oven function and temperature.

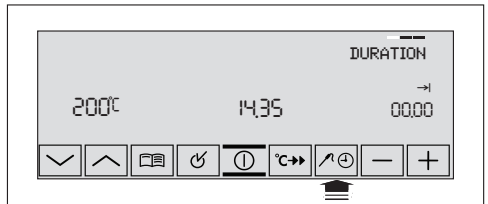

2. Press the SELECTION button repeatedly until DURATION and the symbol is displayed.

- Using the or button, set the desired cooking time.

After about 5 seconds the remaining cooking time is displayed. The symbol lights up. When the time has elapsed, an audible signal sounds for 2 minutes. The oven switches itself off.

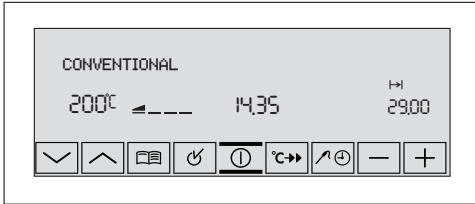

“00.00” and the symbol flash.

END

To set when the oven is to switch off again.

- Select the oven function and temperature.
- Press the SELECTION button repeatedly until END and the symbol are displayed.



- Using the or button, set the desired switch-off time.

After about 5 seconds the switchoff time is displayed. The symbol illuminates. When the time has elapsed, an audible signal sounds for 2 minutes. The oven switches itself off. “00.00” and the symbol flashes.

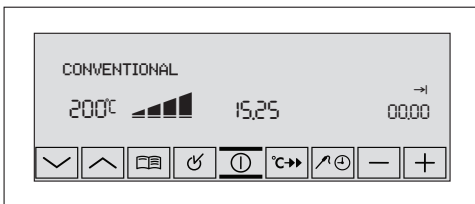

DURATION and END combined

i DURATION and END can be used simultaneously, if the oven is to be switched on and off automatically **at a later time**.

- Select the oven function and temperature.
- Using the DURATION function, set the time that the dish needs to cook.
- Using the END function, set the time at which the dish should be ready. In the text line is shown PROGRAMMED.

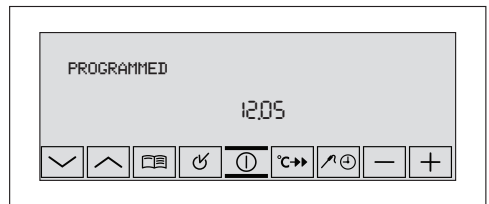

The oven switches itself on automatically at the time calculated,

When the set cooking time has elapsed, an audible signal sounds for 2 minutes and the oven switches itself off.



To change TIME OF DAY

To set, change or check the time (See also section “Before Using for the First Time”).

i The time can only be modified, if the child lock device is deactivated, neither of the clock functions DURATION or END and no oven function is set.

- Switch on the appliance.

2. Press the SELECTION button repeatedly until TIME OF DAY and the symbol are displayed.

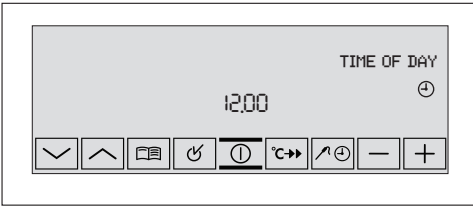

3. Using the or button, set the current time.

4. Confirm using the SELECTION button. The appliance is now ready to use.

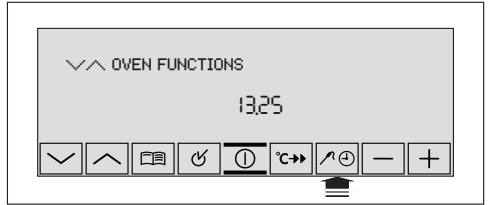

Cleaning and care



Warning! First switch off the appliance and let it cool down before carrying out any cleaning.



Warning! For safety reasons, do **not** clean the appliance with steam blasters or high-pressure cleaners.

Attention: Do not use any corrosive cleaning fluids, sharp objects or stain removers.

Do not clean the glass oven door with abrasive fluids or metal scrapers, which could scratch the surface. The glass could crack and shatter.

Outside of the appliance

- Wipe the front of the appliance with a soft cloth and a solution of hot water and washing up liquid.
- For metal fronts, use normal commercially available cleaning agents.
- Please do not use scouring agents and abrasive sponges.

Oven interior

Clean the appliance after each use. In this way, dirt is easier to clean off and is not allowed to burn on.

1. When the oven door is opened, the oven light switches itself on automatically.
2. After every use, wipe the oven with a solution of washing-up liquid and allow to dry.







Remove stubborn dirt with special oven cleaners.

Important! If using an oven cleaner spray, please follow the manufacturer's instructions exactly.

Accessories

Wash all slide-in units (shelf unit, baking tray, shelf support rails etc.) after each use and dry well. Soak briefly to make them easier to clean.

STEAM CLEANING

1. Place water (approx. 150ml) and 1 tablespoon of vinegar directly into the steam generator.
2. Using the OPTION  button
3. Using the arrow buttons  or , select the menu option CLEANING MENU.
4. Confirm using the OK  button. The oven now heats up to the required temperature. The duration of the process (15 mins.) is shown in the display.
5. When the STEAM CLEANING programme is completed, an audible signal sounds.

 The audible signal can be stopped by pressing any button.

6. Wipe out the oven with a soft cloth. Remove any residual water from the steam generator.

To completely dry the oven, leave the oven door open for around 1 hour

Side rails

For cleaning the side walls the oven's side rails can be removed.

Taking out the side rails

1. Carefully pull the rail up and out of the front catch.

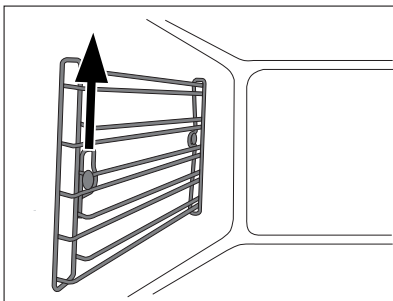

2. Gently swing the rail on the front catch inwards.

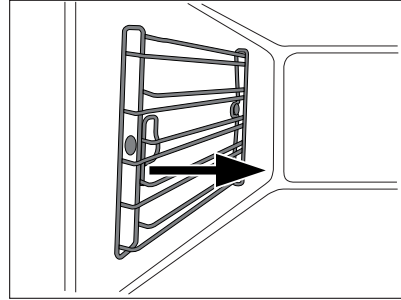

3. Pull the rail out of the rear catch.

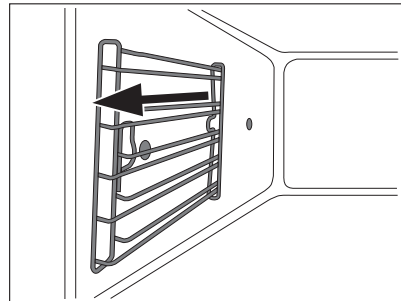

 To remove/replace the side rails, open the cover on the MEAT PROBE socket.

Replacing the side rails

1. Insert the rail at an angle from above and along the side wall into the rear catch.

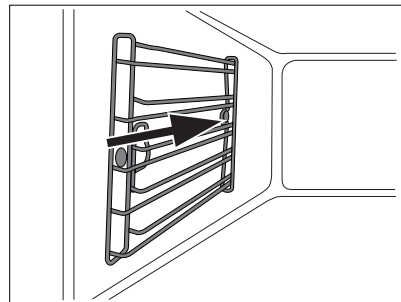

2. Swing the rail on the front catch above the bolts towards the wall.

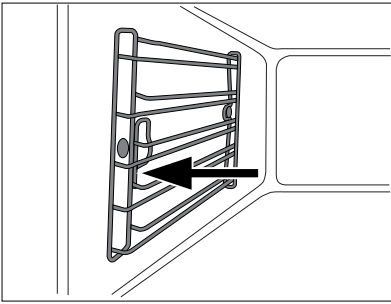

3. Insert the rail into the front catch.

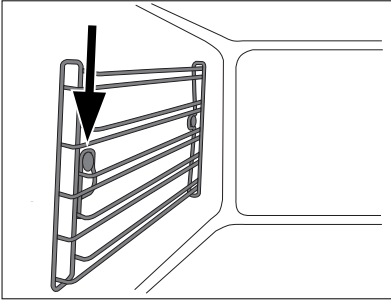

Oven light



Warning! Danger of electrocution! Before replacing the oven light bulb:

- Switch off the oven.
- Take the fuses out of the fuse box, or switch off.



To protect the oven light bulb and the glass cap, lay a cloth on the bottom of the oven.

Replacing the rear oven light bulb/ cleaning the glass cap

1. Take off the cap by turning to the left.
2. Remove seals and metal ring, and clean the glass cap.
3. If necessary: **replace bulb with a 25 Watt, 230V, 300°C heat-resistant oven light bulb.**

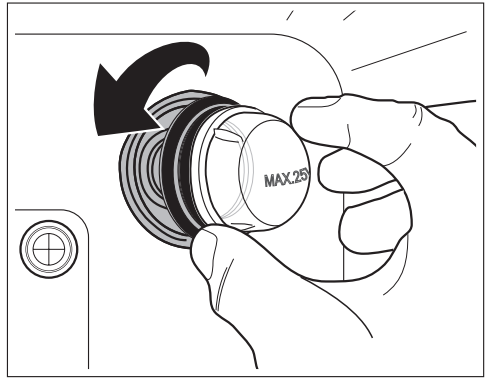

4. Fit seals and metal ring to the glass cap.
5. Re-fit the glass cap.

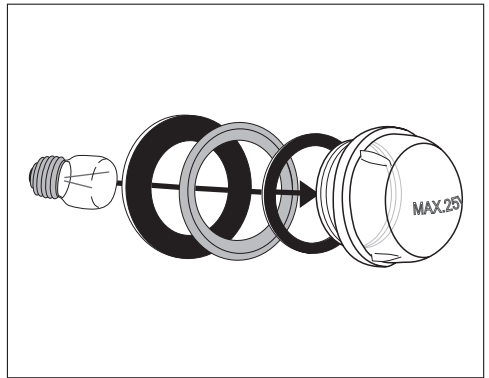

Replacing the oven side light bulb/ cleaning the glass cap

1. Take out the side rails.
2. Unscrew the metal frame using a cross-tip screwdriver.
3. Take off the metal frame and seal, and clean.
4. If necessary: **replace bulb with a 25 Watt, 230V, 300°C heat-resistant oven light bulb.**

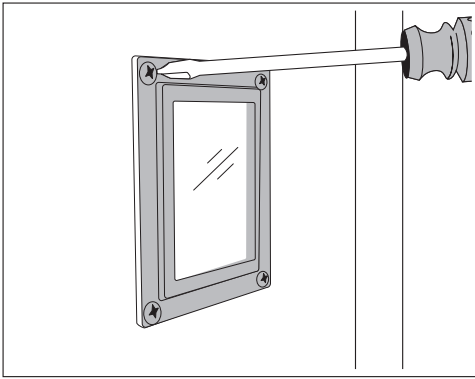

5. Put the metal frame and seal back in place, insert screws, and tighten.
6. Replace the side rails.

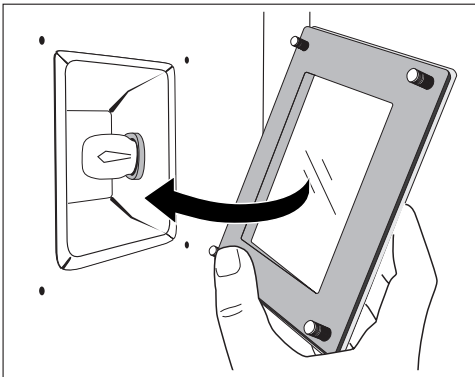

Oven door glass and water collecting channel

The oven door is fitted with three panels of glass mounted one behind the other and a water collecting channel. The inner panels and the water collecting channel can be removed for cleaning.

Important! Rough handling, especially around the edges of the front panel, can cause the glass to break.

Removing the door glass and water collecting channel

1. Open the oven door as far as it will go.

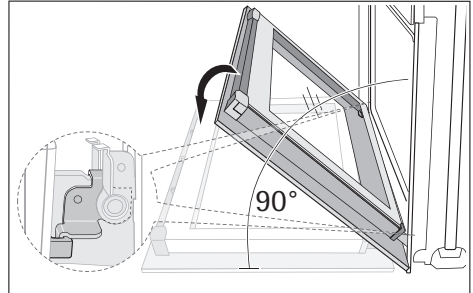

2. Undo the **clamping levers (A)** on both door hinges **fully**.

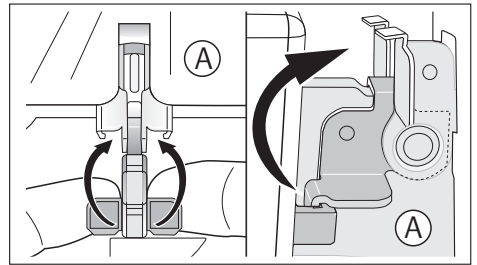

3. Close the oven door as far as the first position (approx. 45°).

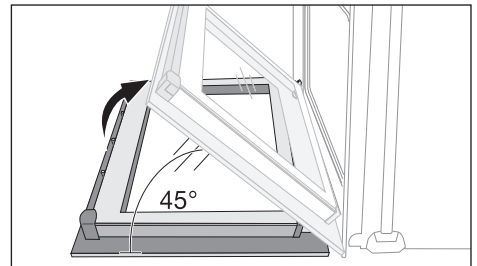

4. Take hold of the door trim (B) on the upper edge of the door at both sides and press inwards to release the clip seal. Then remove the door trim by pulling upwards.

Cleaning the door glass and the water collecting channel

Clean the door glass panels and the water collecting channel thoroughly with a solution of water and washing-up liquid. Then dry them carefully.

Inserting door glass panels and the water collecting channel

1. Insert the snap-in hook of the water collecting channel sideways into the guide. Apply some pressure from above to snap in hook on the other side.

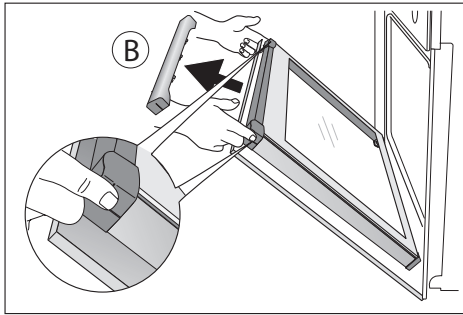

5. Hold the upper edge of the door glass and take it out of the guide by pulling it upwards.

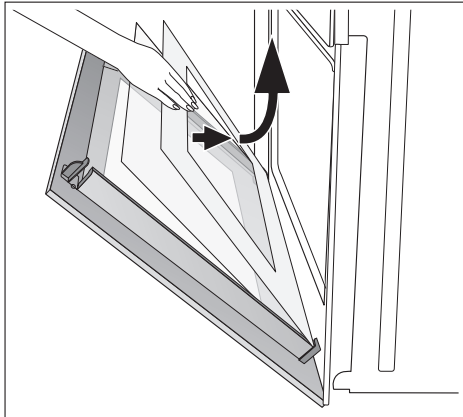

6. Tip the water collecting channel towards the door glass and lift upwards to remove from the guide.

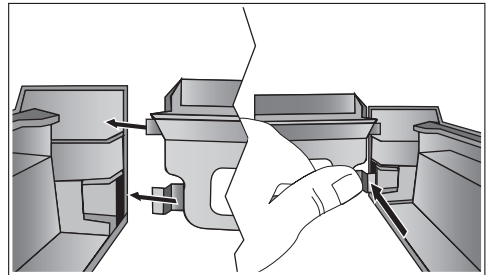
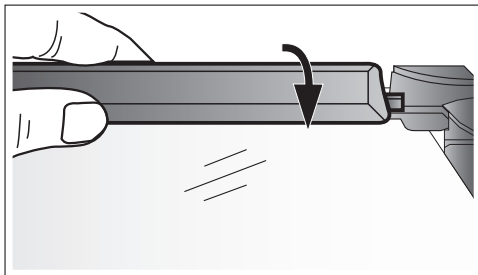

2. From above, insert the door glass at an angle into the door profile at the bottom edge of the door and lower it.

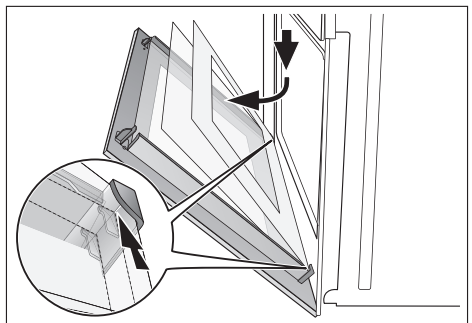

3. Take hold of the door trim (B) at each side, position it on the inside edge of the door and push the door trim (B) onto the upper edge of the door.

- i** On the open side of the door trim (B) there is a guide bar (C). This must be pushed **between** the outer door panel and the guide rail (D). The clip seal (E) must be snapped in.

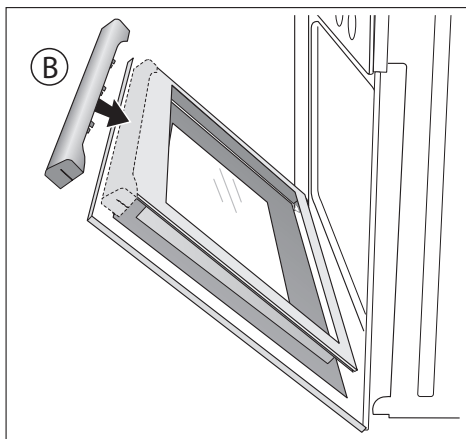

4. Open the oven door as far as it will go.

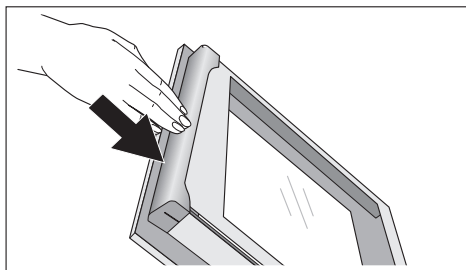
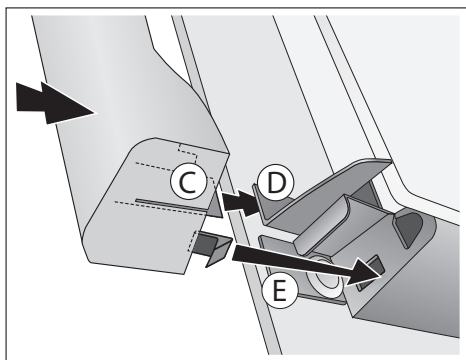

5. Fold up the clamping levers (A) on both door hinges back into their original positions.

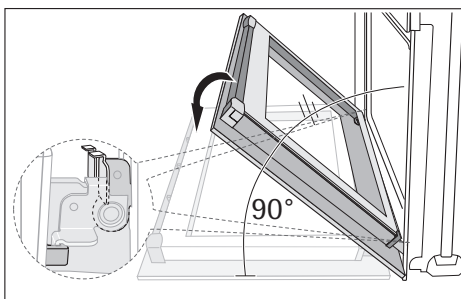

6. Close the oven door.

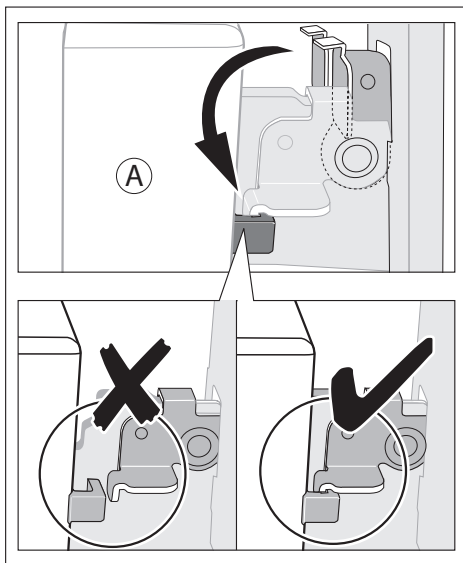

Something not working

If the oven is not working correctly, please carry out the following checks, before contacting your local Service Force Centre.

Important! If you call out an engineer to a fault listed below, or to repair a fault caused by incorrect use or installation, a charge will be made even if the appliance is under guarantee.

Problem	Possible cause	Possible solutions
The oven is not heating up	The oven has not been switched on	Switch oven on
	The clock has not been set	Set the current time on the clock
	The required settings have not been set	Check the settings
	The oven's automatic cut-out has been triggered.	See Automatic cut-out
	The house wiring fuse (in the fuse box) has tripped	Check fuse. If the fuses trip several times, please call a qualified electrician
The oven lighting is not operating	The oven light bulb is faulty	Replace oven light bulb
F11 appears in the clock display	The meat probe has short circuited or the plug of the meat probe is not firmly in position in the socket	Insert the meat probe plug into the socket on the oven side wall as far as it will go.
A fault code that is not listed above appears in the clock display	Electronic fault	Switch the appliance off and on again via the house fuse or the safety switch in the fuse box. If it is displayed again, please contact the Customer Care Department

If you are unable to remedy the problem by following the above suggestions, please contact your dealer or our extended warranty administrators on 0870 010 7887 who will give you the details of your local repair agent.



Warning! Repairs to the appliance are only to be carried out by qualified service engineers. Considerable danger to the user may result from improper repairs.



If you call an engineer to a fault listed in the table, or to repair a fault caused by incorrect use or installation, a charge will be made even if the appliance is under guarantee.

Advice on cookers with metal fronts:



Because of the cold surface at the front of the cooker, opening the oven door during (or just after) baking or roasting may cause the glass to steam up.

Disposal

The symbol  on the product or on its packaging indicates that this product may not be treated as household waste. Instead it should be taken to the appropriate collection point for the recycling of electrical and electronic equipment. By ensuring this product is disposed of correctly, you will help prevent potential negative consequences for the environment and human health, which could otherwise be caused by inappropriate waste handling of this product. For more detailed information about recycling of this product, please contact your local council, your household waste disposal service or the shop where you purchased the product.

Old appliance



Warning! So that the old appliance can no longer cause any danger, make it unusable before disposing of it.

To do this, disconnect the appliance from the mains supply and remove the mains cable from the appliance.

Packaging material



The packaging materials are environmentally friendly and can be recycled. The plastic components are identified by markings, e.g. >PE<, >PS<, etc. Please dispose of the packaging materials in the appropriate container at the community waste disposal facilities.

Electrical connections

The oven is designed to be connected to 230-240V~(50Hz) electricity supply.

The oven has an easily accessible terminal block which is marked as follows:

Letter L - Live terminal

Letter N - Neutral terminal

⊕ - Earth terminal



Caution! This oven must be earthed!

The cable used to connect the oven to the electrical supply must comply to the specifications given below.

For UK use only

Connection via	Min. size Cable/flex	Cable/flex type	Fuse
Cooker Control Circuit	2,5 mm ²	PVC/PVC twin and earth	min: 15 A max: 20 A

It is necessary that you install a double pole switch between the oven and the electricity supply (mains), with a minimum gap of 3 mm between the switch contacts and of a type suitable for the required load in compliance with the current regulations.

The switch must not break the yellow and green earth cable at any point.

Important! After installation and connecting, the cable must be placed so that it cannot at any point reach a temperature of more than 50°C above the ambient temperature.

Before the oven is connected, check that the main fuse and the domestic installation can support the load; and that the power supply is properly earthed.

The manufacturer declines any responsibility should these safety measures not be carried out.

Installation instructions

Important! IMPORTANT

The new appliance may only be installed and connected by a qualified installation engineer. Please comply with this instruction. If you do not, any damage resulting is not covered by the warranty.

Safety information for the installer

- The set-up of the electrical installation is arranged so that the appliance can be isolated from the mains with a minimum 3 mm all-pole contact separation. Suitable isolation devices include, for example, circuit breakers, fuses (screw type fuses are to be removed from the holder), RCDs and contactors.
- Anti-shock protection must be provided by the installation.

- The built-in unit must meet the stability requirements of DIN 68930.
- Built-in cookers and cooking surfaces are equipped with special attachment systems. For safety reasons, they must only be combined with appliances from the same manufacturer.

The use of heat protection strips is prohibited for cookers and ovens with Pyrolytic, if the recess has a rear wall and closed ground-level compartment. However installation is possible with a ground-level compartment that has been shortened by at least 20 mm and which has base ventilation of the same cross-section.

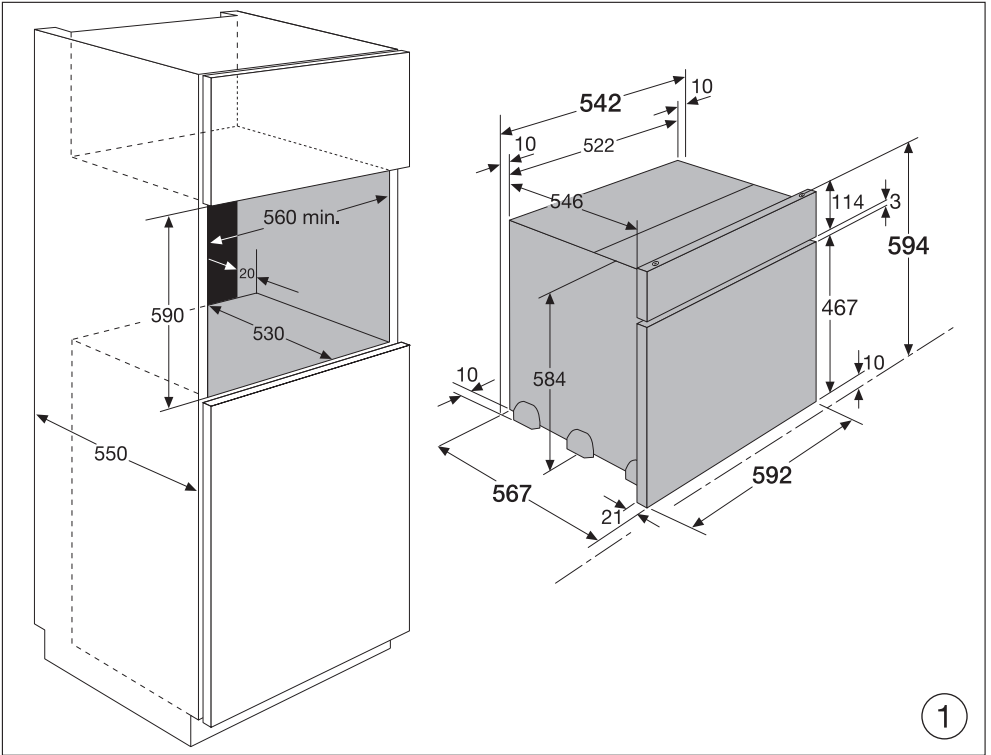

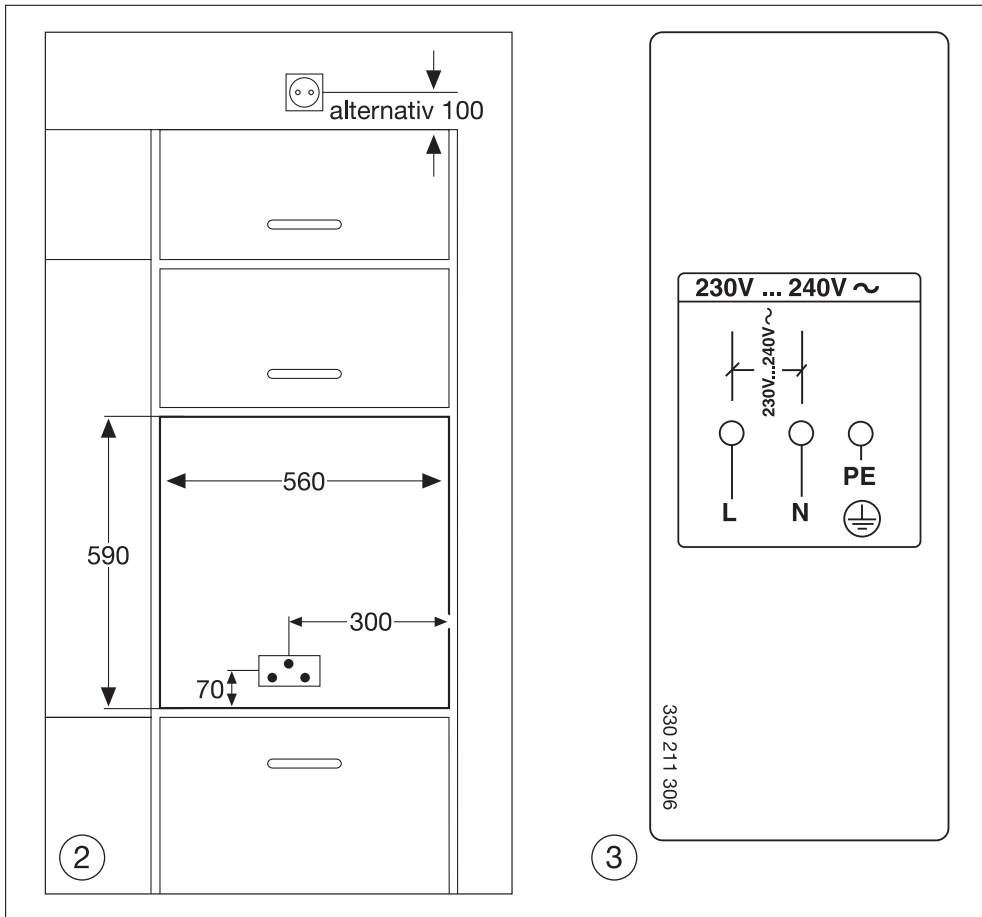

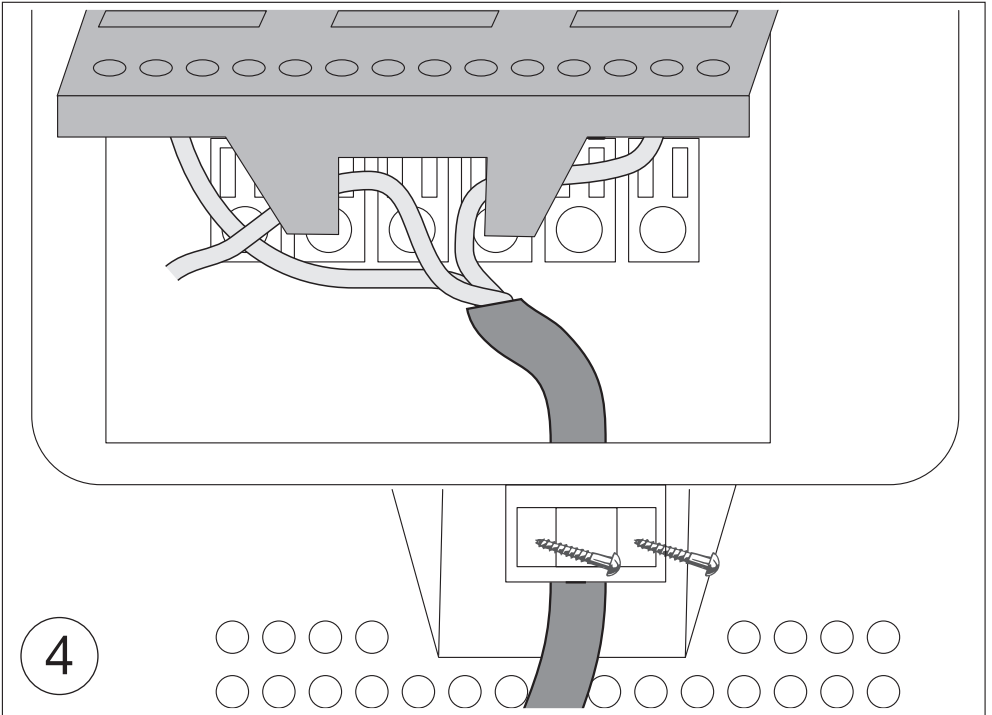

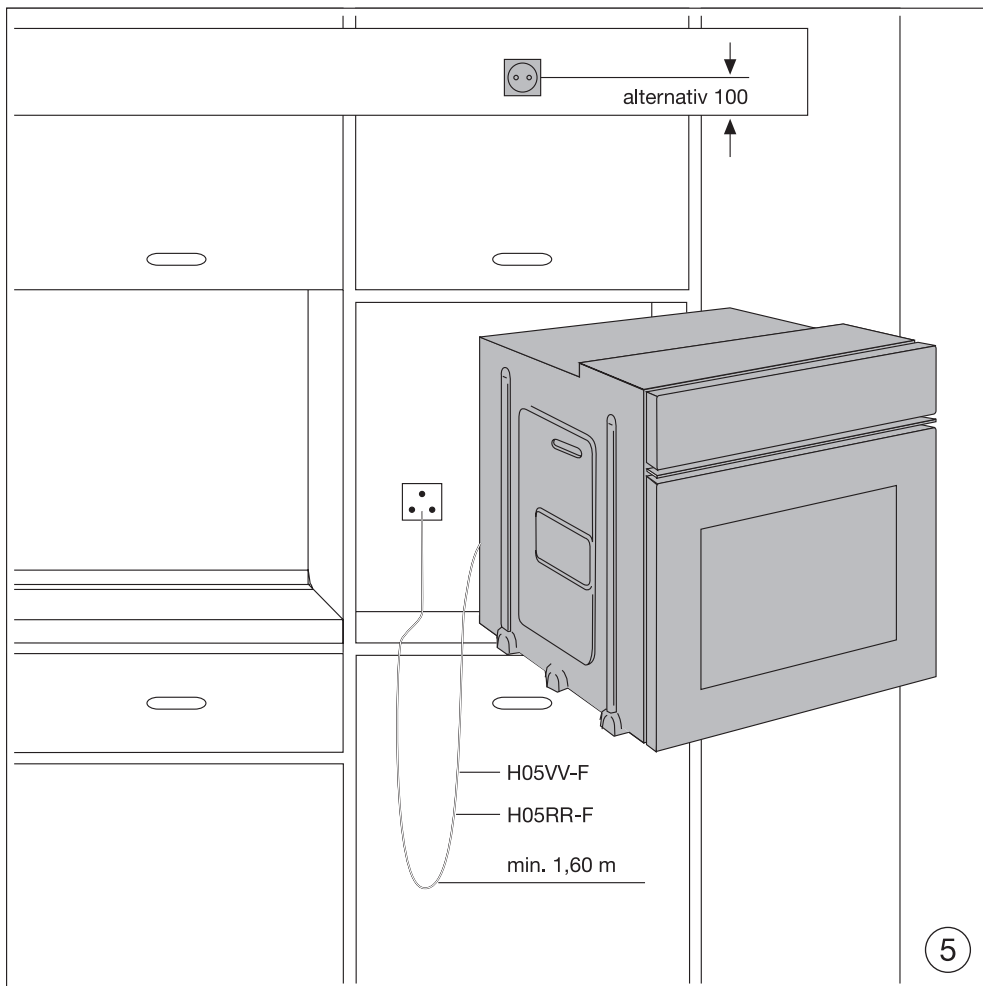

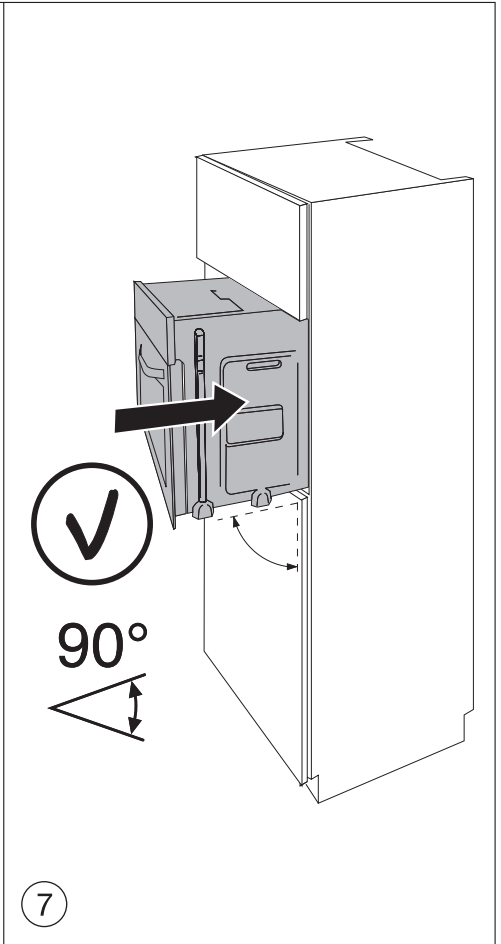
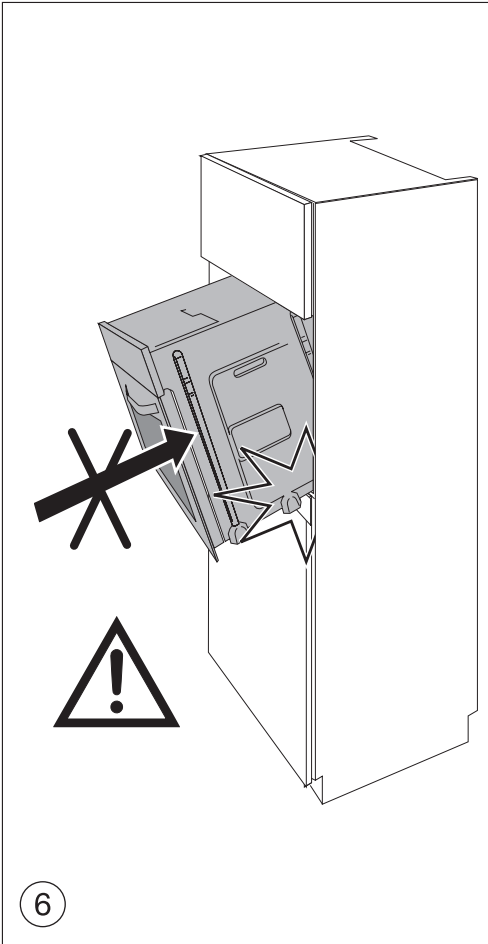

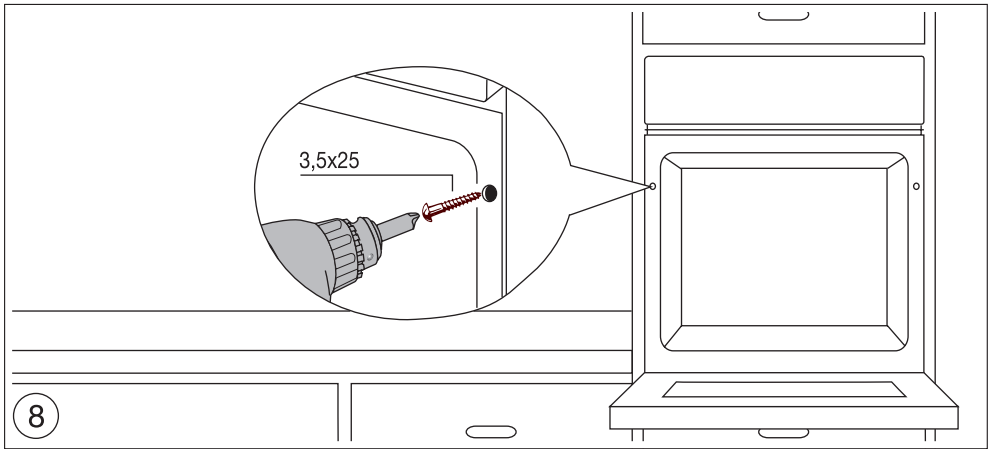

Technical data

Voltage:	230/240 Volts 50 Hz
Wattage:	3.5 kW
Height:	594 mm
Width:	592 mm
Depth: (excluding handles and knobs)	567 mm
Weight:	49 kg



This appliance complies with:
 European Council Directive 73/23/
 EEC
 EMC Directive 89/336/EEC CE
 Marking Directive 93/68/EEC
 Energy Label Directive 2002/40/EC

Repairs - after sales service

Your appliance comes with a three year warranty. If it is not working correctly; consult the fault finding guides within this instruction book (Something not working). If a fault occurs which you can not resolve through following the advice and information contained within this instruction manual, the next step is to contact our extended warranty administrators on:

0844 871 7771

They will give you details for your local Service engineer. Before calling out an engineer, please ensure you have read the details under the heading "Something not working".

When you contact your local service engineer you will need to give the following details:

1. Your name, address and post code
2. Your telephone number
3. Clear and concise details of fault
4. The purchase date as found on your receipt
5. The model and serial number of the appliance. So that you always have these numbers at hand, we recommend you to make a note of them here:

- Mod.....
- P.N.C.....
- S.N.....

IMPORTANT : If you call out an engineer to a fault listed below, or to repair a fault caused by incorrect use or installation, a charge will be made

even if the appliance is under guarantee.

Spare parts

This oven should be serviced by any authorised service engineer; and only genuine spare parts should be used. Under no circumstances should you attempt to repair the oven yourself.

Repairs carried out by inexperienced persons may cause injury or serious malfunctioning.

Contact our extended warranty administrators on

0870 010 7887

who will give you details for your Service Force repair agent.

Always insist on genuine spare parts.

John Lewis Partnership

171 Victoria Street
London SW1E 5NN
www.johnlewis.com

Free Manuals Download Website

<http://myh66.com>

<http://usermanuals.us>

<http://www.somanuals.com>

<http://www.4manuals.cc>

<http://www.manual-lib.com>

<http://www.404manual.com>

<http://www.luxmanual.com>

<http://aubethermostatmanual.com>

Golf course search by state

<http://golfingnear.com>

Email search by domain

<http://emailbydomain.com>

Auto manuals search

<http://auto.somanuals.com>

TV manuals search

<http://tv.somanuals.com>