

JLFFW2004

frost free fridge freezer

Instruction manual



John Lewis

Important safety information

It is most important that this instruction book should be retained with the appliance for future reference. Should the appliance be sold or transferred to another owner, or should you move house and leave the appliance, always ensure that the book is supplied with the appliance in order that the new owner can get to know the functioning of the appliance and the relevant warnings.

These warnings have been provided in the interest of safety. You **MUST** read them carefully before installing or using the appliance.

If you are unsure of the meanings of these warnings contact the John Lewis branch from which you purchased the appliance.

Installation

- This appliance is heavy. Care should be taken when moving it.
- Check your Fridge Freezer for any transport damage. Do not connect the appliance if there is damage. If the Fridge Freezer is damaged, you should contact the John Lewis branch from which you purchased it.
- Any electrical work required to install this appliance should be carried out by a qualified electrician or competent person.
- Care must be taken to ensure that the appliance does not stand on the electrical supply cable. If the supply cable is damaged it must be replaced; contact our extended warranty administrators on 08700 107 887 who will give you details for your local Service Force centre.
- Parts, which heat up, should not be exposed. Whenever possible, the back of the appliance should be close to a wall, but leaving the required distance for ventilation, as stated in the installation instructions.
- This appliance should be left for 2 hours after installation before it is turned on, in order to allow the refrigerant to settle. Before switching on the Fridge Freezer ensure that the interior light bulb and cover are in position. Do not connect the appliance if they are not.

Child safety

- This appliance is designed to be operated by adults. Children should not be allowed to tamper with the controls or play with the product.
- Keep all packaging well away from children.
- When the appliance is to be scrapped, cut off the electrical supply cable and destroy the plug with the remaining cable. Disable the door catch in order to prevent children from becoming trapped inside while playing.

Use

- This appliance is designed for domestic use only, specifically for the storage of edible foodstuffs only.
- It is not intended for commercial or industrial use.
- Containers with flammable gases or liquids can leak at low temperatures. Do not store any containers with flammable materials, such as spray cans, fire extinguisher refill cartridges etc. in the refrigerator or the vicinity of the refrigerator or any other appliance.
- Frozen food should not be refrozen once it has thawed out.
- Do not place carbonated or fizzy drinks in the freezer compartment.
- Ice lollies can cause frost/freezer burns if consumed straight from the freezer compartment.
- Do not remove items from the freezer compartment if your hands are damp/wet, as this could cause skin abrasions or frost/freezer burns.
- Bottles and cans must not be placed in the freezer compartment as they can burst as the contents freeze.
- Manufacturers recommended food storage times should be adhered to.
- Refer to the relevant instructions.
- Do not use electrical appliances inside the Refrigerator.
- Store pre-packed frozen foods in accordance with the frozen foods instructions and use by date.
- When cleaning or taking out frozen foods or the ice tray do not use sharp, pointed or hard devices, as they can cause damage to the appliance.
- Do not damage the refrigerant circuit.

Safety precautions for isobutane

Warning

- The refrigerant of the appliance is isobutane (R600a) that is inflammable and explosive to a greater extent.
- Keep ventilation openings, in the appliance enclosure or in the built-in structure, clear of obstruction.
- Do not use mechanical devices or other means to accelerate the defrosting process, other than those recommended by the manufacturer.
- Do not damage the refrigerant circuit.
- Do not use electrical appliances inside the food storage compartments of the appliance, unless they are of the type recommended by the manufacturer.

For the safety of life and property keep the precautions of these user's instructions as the manufacturer is not responsible for damages caused by omission.

Maintenance and Cleaning

- Before cleaning, always switch off the appliance and disconnect from the electrical supply.
- Check and clean the drain in the refrigerator compartment for defrosted water regularly; if the drain is blocked, water will gather in the bottom of the refrigerator.
- When unplugging always pull the plug from the mains socket, do not pull on the cable.
- Further information on cleaning is on page 18 of this manual.

Service

- This product should only be serviced by an authorised engineer and only genuine spare parts should be used.
- Under no circumstances should you attempt to repair the appliance yourself. Repairs carried out by inexperienced persons may cause injury or serious malfunction.

Service Force are the authorised repair agents for John Lewis branded domestic appliances.

Ecological hints

To save energy and help protect the environment, we recommend that you follow these hints.

Do not install the appliance close to sources of heat such as a boiler or radiator.

Locate the appliance in a well-ventilated room and make sure that any air openings of the appliance are not obstructed.

Pack all foods into airtight packages before placing them into the freezer compartment.

Food, which is to be frozen (when cool), should be placed in the fridge compartment before being transferred to the freezer.

try to avoid keeping the door open for long periods or opening the door too frequently as warm air will enter the cabinet and cause the compressor to switch on unnecessarily often.

Ensure there are no obstructions preventing the door from closing properly.

Environmental information

After unpacking please dispose of the packaging with due regard to safety and the environment.

Materials marked with the symbol  are recyclable.

Avoid damaging the cooling unit, especially at the rear near the heat exchanger. Check with your local Council or Environmental Health Office to see if there are facilities in your area for recycling this appliance.

When the appliance is to be scrapped, cut off the power supply cable and remove the door, to prevent young children from being trapped inside.

This appliance does not contain gases, which could damage the ozone layer; in either, its refrigerant circuit or insulation materials.

WARNING

A cut off plug inserted into a 13-amp socket is a serious safety (shock) hazard. Please ensure the cut off plug is disposed of safely.

The symbol  on the product or on its packaging indicates that this product may not be treated as household waste.

Instead it shall be handed over to the applicable collection point for the recycling of electrical and electronic equipment. By ensuring this product is disposed of correctly, you will help prevent potential negative consequences for the environment and human health, which could otherwise be caused by inappropriate waste handling of this product. For more detailed information about recycling of this product, please contact your local city office, your household waste disposal service or the shop where you purchased the product.

Contents

For the User

Important safety information	2
Installation	2
Description of the appliance	5
The Control Panel	10
Putting it into use	10
Display background colour	11
Controlling the temperature, setting	11
Using the refrigerator	12
Drawer	12
Shopping mode	12
Storing in foods the refrigerator	12
Storage time and temperature of foods	12
Using the freezer	13
Freezing	13
Storing in the freezer	13
How to make ice cubes	13
Storage time chart (refrigerator)	14
Storage time chart (freezer)	15
Maintenance and Cleaning	16
Defrosting	16
Regular cleaning	16
Internal cleaning	16
External cleaning	16
Something Not Working	17
Repairs - After Sales Service	18

For the Installer

Installation	6
Technical Specifications	6
Unpacking	7
Cleaning	7
Positioning	7
Climate Classification	7
Change of door opening direction	8
Electrical connection	9

Guide to the Instruction Manual

The following symbols will be found in the text to guide you throughout the instructions:



Safety precautions

Warnings and information at this symbol serve safety for you and your appliance.



Hints and tips



Environmental information



This appliance complies with the following E.E.C. Directives:

- 73/23 EEC of 19.02.73 (Low Voltage Directive) and subsequent modifications,
- 89/336 EEC of 03.05.89 (Electromagnetic Compatibility Directive) and subsequent modifications.

Description of the appliance

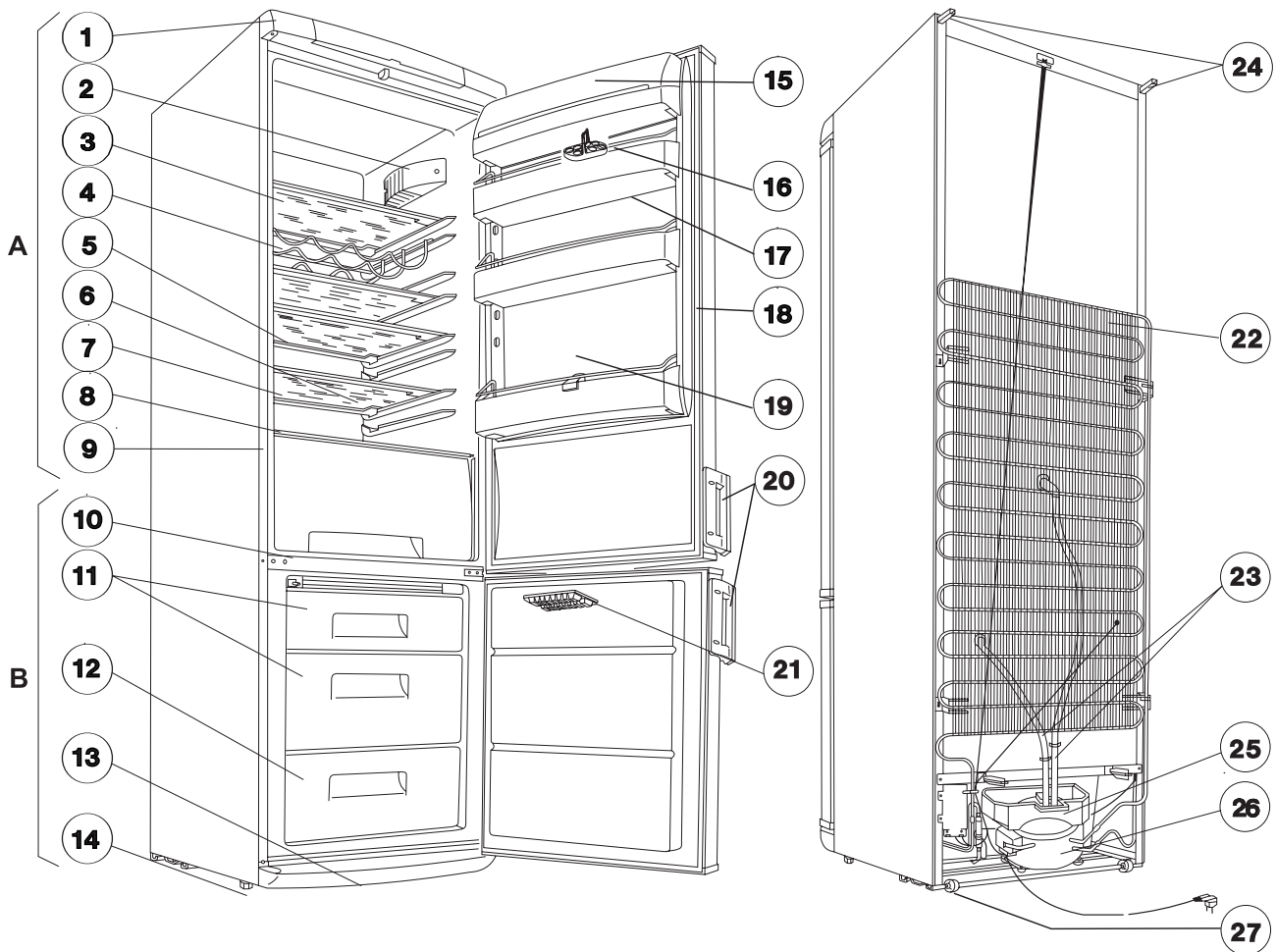



A- Refrigerator

B - Freezer

- | | |
|--------------------------------------|-------------------------------|
| 1. Top with switch and indicator set | 14. Adjustable feet |
| 2. Lighting box | 15. Butter compartment lid |
| 3. Glass shelves | 16. Egg tray |
| 4. Bottle rack | 17. Door shelf |
| 5. Cooling surface | 18. Door gasket |
| 6. Defrost water drain | 19. Bottle shelf |
| 7. Glass shelf | 20. Handles |
| 8. Drawer | 21. Ice tray |
| 9. Rating plate | 22. Condenser |
| 10. Air grid | 23. Defrost water outlet tube |
| 11. Storing compartment(s) | 24. Spacer |
| 12. Freezing compartment | 25. Evaporator tray |
| 13. Bottom plinth | 26. Compressor |
| | 27. Rollers |

Installation

-  It is dangerous to alter the specifications or attempt to modify this product in any way.
-  Care must be taken to ensure that the appliance does not stand on the electrical supply cable.
-  Any electrical work required to install this appliance should be carried out by a qualified electrician or competent person.

Technical Specifications

Dimensions	Width	595 mm
	Height	2010 mm
	Depth	632 mm
Power supply voltage		230V/50Hz
Rated current		0,8 A
Gross capacity	Refrigerator	291 l
	Freezer	91 l
Net capacity	Refrigerator	285 l
	Freezer	78 l
Freezing capacity		6 kg/24 h
Energy consumption		1,025 kWh/24h
		374 kWh/year
Energy class, according to EU standards		A
Rising time		18 h
Noise Lc		42 dB
Weight		72 kg
Number of compressors		1

Unpacking

i The appliance must always be transported in the vertical position as indicated on the outside of the packaging.

After each transportation the appliance must not be switched on for approx. 2 hours.

To ensure the coolant gases settle.

Unpack the Fridge Freezer and check for any possible damage. If the appliance is damaged please report this to the John Lewis branch from which you purchased; in this case please retain the packaging. Report possible damages immediately to the place you bought it. In that case retain packaging.

Cleaning

Remove all adhesive tape and ties, which ensure the internal fittings do not move during transportation.

Wash the inside of the appliance using lukewarm water and mild detergent; using a soft cloth.

Further cleaning advice is given on page 18. wipe out the inside of the appliance.

Positioning

The appliance should be located in a well ventilated, dry room. To ensure correct operation the appliance should:

- Not be exposed to direct sunlight.
- Not be installed next to radiators, cookers or other sources of heat.
- Only be installed in a location where the ambient temperature corresponds to the climate classification for which the appliance is designed.

Climate Classification

The climate classification can be found on the rating plate; which is located on the bottom left hand side of the fridge compartment, see page 5' .

The table shows the correct operating ambient temperature for each climate class.

Class of climate	Ambient temperature
SN	+10...+32°C
N	+16...+32°C
ST	+18...+38°C

If the temperature rises above or falls below the stated ambient temperature for the climate class, the operation of the appliance may be affected.

Ventilation

You should ensure that air could circulate freely around the back and top of the cabinet. In the Instruction manual bag there are two spacers which must be fitted to the top rear corners. This will ensure a gap is maintained between the Fridge Freezer and the wall.

Loosen the screws and insert the spacer under the screw head, then re-tighten the screws.

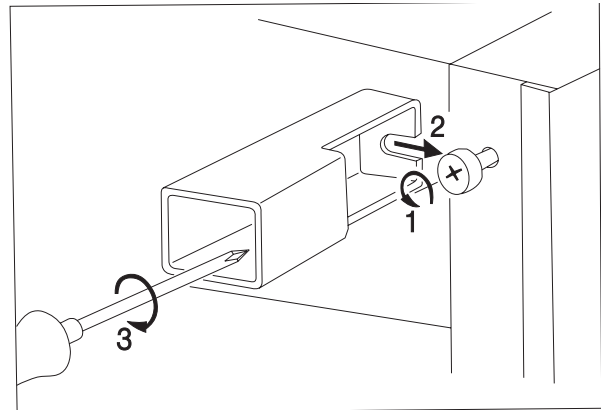

Levelling

When placing the appliance ensure that it stands level, to prevent vibration, excessive noise and to ensure the doors shut correctly.

Level the appliance by turning the 2 adjustable feet at the front of the Fridge Freezer.

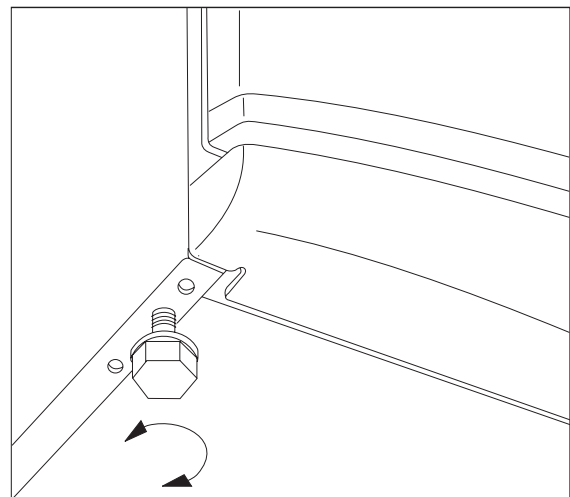

! When placing the refrigerator keep minimal distances recommended in figure.

A: placing it under a wall-cupboard

B: placing it freely

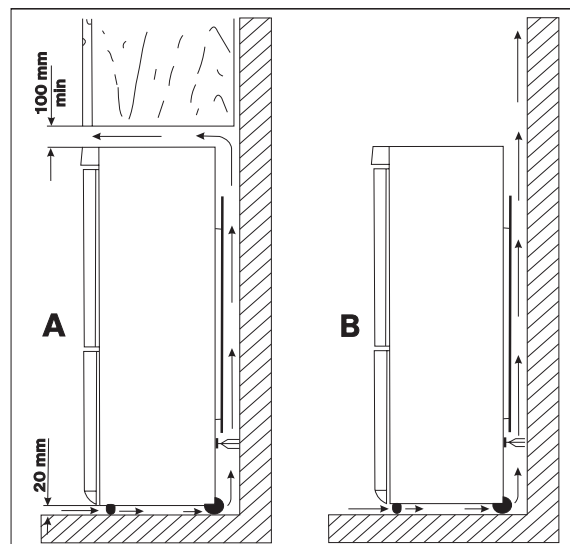

Change of door opening direction

Should the location or handling demand it, door-opening direction can be refitted from right-handed to left-handed.

Appliances on the market are right-handed.

Following operations are to be done on the basis of figures and explanations:

1. To perform the operations listed below it is recommended to ask another person for help while performing the operations.
2. Disconnect the appliance from the electricity supply.
3. Open the doors and dismantle the double door hinge (a,b) by removing the screws (2 pieces) (c). (fig. 2)
4. Take off the double door hinge (a,b,c) by gradually removing it from the cabinet, slightly tilting both doors. Do not forget to remove the plastic spacer (b) under the hinge. (fig. 2)
5. Take off the refrigerator door by pulling it slightly downwards.
6. Take off the freezer door by pulling it slightly upwards.
7. Unscrew the top door hinge pin (d) of the refrigerator then screw it back on the other side. (fig. 1)
8. Remove the insert of the plinth (e) by a screwdriver. (fig. 3)
9. Unmount the lower hinge pin (f) and its washer (h) and mount them on the other side. (fig. 3)
10. Replace the insert of the plinth (e) on the other side.
11. Remove the blanking pins (3 pieces) (n,k) of the double door holder on the left side and put them to the other side. (fig. 2)
12. Fit the pin of the double door hinge (m) into the left drill of the freezer door. (fig. 2)
13. Fit the freezer door to the lower door hinge pin (f). (fig. 3)
14. Fit the refrigerator door to the upper door hinge pin (d) then slightly tilting both doors fit the pin of the double door hinge (m) into the left drill of the refrigerator door.
15. Opening both doors fix the double door hinge onto the left side using the screws (2 pieces) (c). Do not forget to replace the plastic spacer (b) under the hinge. Be careful that the door edges are parallel with the edge of the top panel.
16. Put over the handles (r) on the other side and put the plastic blanking pins (p) supplied in the plastic bag of this instruction book into the holes set free. (fig. 4)
17. Put the appliance to its place, set it level, and apply to voltage it.

In case you do not want to perform the procedures above, call your local Service Force. Technicians will accomplish the refitting expertly for charge.

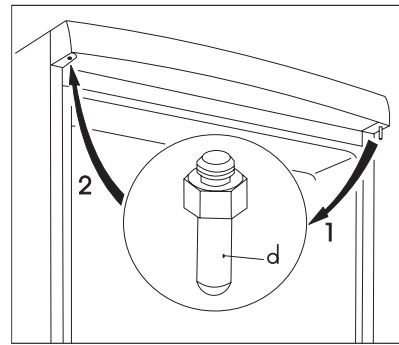

fig. 1.

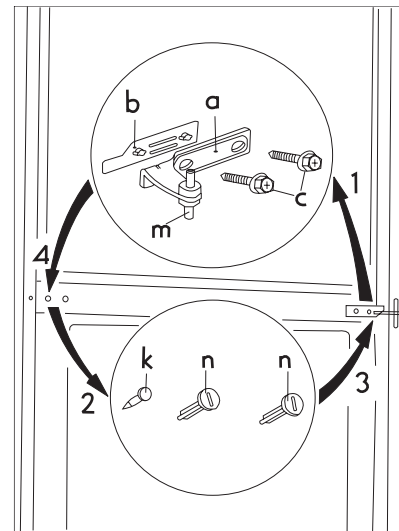

fig. 2.

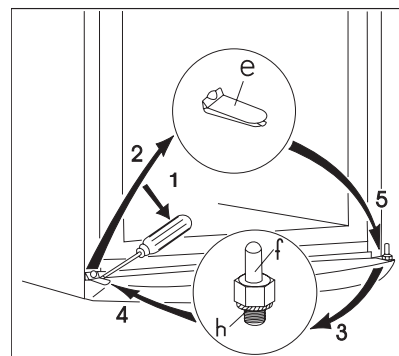

fig. 3.

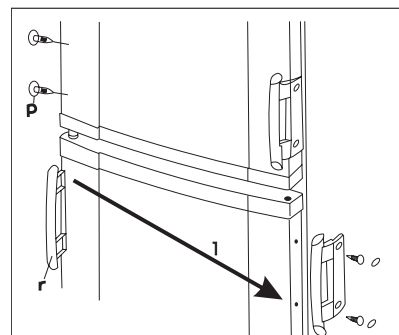

fig. 4.

Electrical connection

Any electrical work required to install this appliance should be carried out by a qualified electrician or competent person.

WARNING: THIS APPLIANCE MUST BE EARTHED.

Should the appliance power supply cable need to be replaced, this must be carried out by a Service Force agent (see page 18)

The manufacturer declines any liability should this safety measure not be observed.

Before switching on, make sure the electricity supply voltage is the same as that indicated on the appliance's rating plate. (See picture on page 5).

The appliance is supplied with a 13amp plug supplied. In the event of having to change the fuse in the plug supplied, a 13amp ASTA approved BS 1363/A fuse must be used.

Should the plug need to be replaced for any reason, proceed as described below. The wires in the mains lead are coloured in accordance with the following code:

Green and Yellow	- Earth
Blue	- Neutral
Brown	- Live

If you fit your own plug, the colours of the wires in the mains lead of your appliance may not correspond with the markings identifying the terminals in your plug.

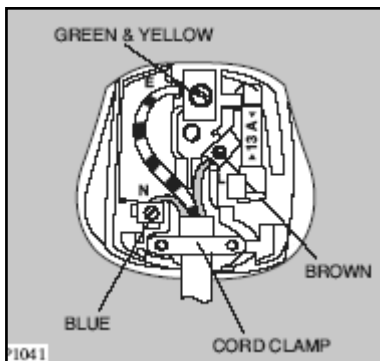

Proceed as follows:

1. Connect the Green and Yellow (earth) wire to the terminal in the plug which is marked with the letter "E" or the earth symbol \oplus or coloured green and yellow.
2. Connect the Blue (neutral) wire to the terminal in the plug which is marked with the letter "N" or coloured black.
3. Connect the Brown (live) wire to the terminal in the plug which is marked with the letter "L" or coloured red.
4. Upon completion there must be no cut, or stray strands of wire present and the cord clamp must be secure over the outer sheath.

WARNING: A cut off plug inserted into a 13 amp socket is a serious safety (shock) hazard.

Ensure that the cut off plug is disposed of safely.

The plug must still be accessible after the appliance has been installed.

The appliance should not be connected to the electrical supply by means of an extension cable

Permanent connection

In the case of permanent connection it is necessary that you install a double pole switch between the appliance and the electricity supply (mains), with a minimum gap of 3mm between the switch contacts and of a type suitable for the required load in compliance with the current electrical regulations.

The switch must not break the yellow and green earth cable at any point.

The Control Panel

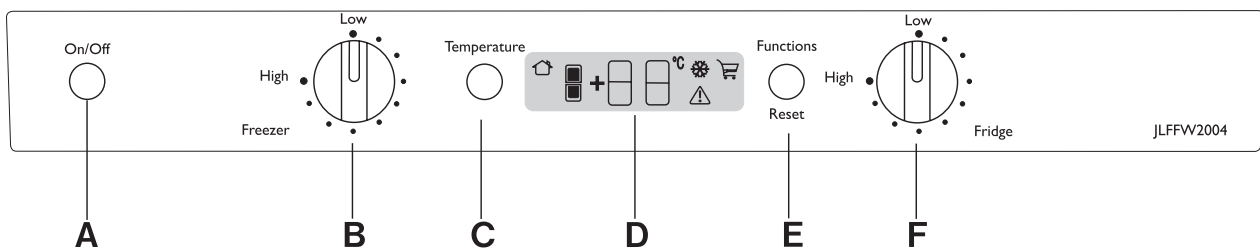

The following controls can be found under a cover in the top frame:

A. On/Off button

Switches the appliance on and off.

B. Freezer thermostat knob

Used to set the temperature inside the freezer.

C. Temperature selection push button

Depress to see the temperatures shown on the LCD display.

To display the refrigerator or freezer temperature, press it once or twice, respectively.

See also the description of the temperature display.

D. Temperature display

See the description in the separate chapter.

E. Function selection/Alarm reset button

Used to select the super cooling and shopping modes. The Modes are available as follows, pressing the button once or more times:

- Normal mode (default)
- Super cooling mode
- Shopping mode
- Normal mode

The same button is used to reset acoustic alarm signal, see the description on the display background colour.

F. Refrigerator thermostat knob

It is used to set the temperature inside the refrigerator.

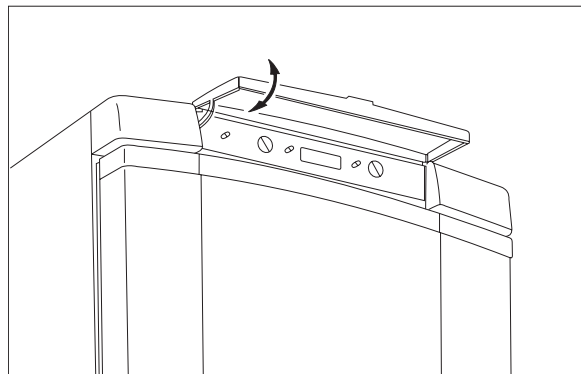

Putting it into use

After connecting to the Electricity supply:

Press the "A" button. The backlight of the display turns on.

The appliance is ready to use.

Pressing the "A" button again the appliance is off, but still connected to the mains voltage.

The elements of the temperature display are as follows:

1. Ambient symbol

Seen when the digits show the ambient temperature.

2. Refrigerator symbol

Dark, when the digits show the refrigerator temperature.

3. Freezer symbol

Dark, when the digits show the freezer temperature.

4. Digits

By default the digits show the ambient temperature and the ambient symbol is seen.

The digits can show also:

- The medium temperature inside the refrigerator after pressing the "C" button (refrigerator symbol is dark), for a while.
- The highest temperature inside the freezer after pressing the "C" button twice (freezer symbol is dark), for a while.
- Refrigerator temperature set (value is blinking) when the "F" knob is rotated and for a while afterwards.
- Freezer temperature set (value is blinking) when the "B" knob is rotated and for a while afterwards.

5. Super cooling symbol

Visible, when the appliance runs in super cooling mode. See also the chapter on freezing.

6. High temperature symbol

Visible, when the temperature in the refrigerator is too high. See also the description on the display background colour.

7. Shopping symbol

Visible, when the appliance runs in shopping cooling mode. See also the chapter on using the refrigerator.

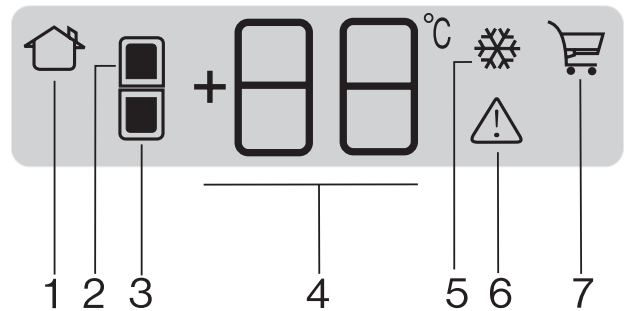

Display background colour

By default the display background is blue.

When ever a control button or knob is used the background turns bright blue and remains so for a while.

The display background turns red, if the temperature inside the freezer is too warm (alarm). If this is the case, the digits blink the warmest temperature inside the freezer, the high temperature symbol flashes and an acoustic alarm signal is shown.

The temperature might be too warm in the following cases:

- Immediately after switching on
- The freezer door was left open for a longer time
- There is an operating trouble in the freezer

To switch the alarm sound off press the "E" button. The display returns to showing the ambient temperature, however the background remains red until the freezer cools down properly.

Should you press no button during alarm, press the "E" button when the sound finishes to see the warmest temperature reached during the alarm.

Controlling the temperature, setting

The Thermostat will stop and start the cooling system as frequently as is required to maintain the temperatures set within the two compartments.

Temperature of the refrigerator and freezer can be set by knobs "F" and "B", respectively. The set temperature is seen blinking on the display.

For everyday use the setting in the refrigerator should be +5°C; in the freezer the setting would be -18°C recommended, or slightly colder.

Allow the appliance to run for a period of 24 hours whenever the temperature setting is changed. This will allow the temperature to stabilise inside the appliance.

The temperature within the refrigerator is influenced by varying factors, the thermostat setting, the ambient room temperature, the frequency that the door is opened and closed and the quantity of food stored within.

i When the coldest temperature possible is set - when there are eases of increased demand e.g. during heatwaves - the compressor may operate continually. This does not cause damages to the appliance.

Using the refrigerator

i For adequate cooling developing interior air circulation is necessary. For this reason you are asked not to cover the air circulation gaps behind the shelves (e.g. with tray etc.).

i Do not put hot food into the refrigerator. Allow it to reach room temperature naturally. In this way unnecessary frost building up can be avoided.

i Foods can take over odours from each other. So it is essential to put foods in closed dishes or wrap them in cellophane, aluminium foil, grease-proof paper or cling film before placing them into the refrigerator. This way foods will keep their moisture e.g. vegetables will not dry out after some days.

Drawer

The drawer is suitable for storing fruit and vegetables.

There is a separator inside the drawer that can be placed in different position to allow for the subdivision best suited to personal needs.

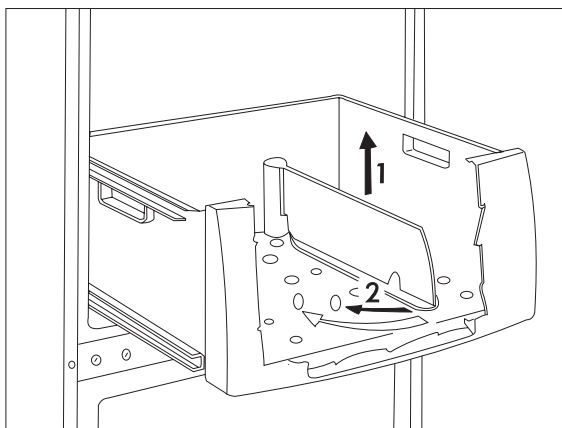

Shopping mode

Before putting a bigger amount of food into the refrigerator (e.g. when returning from shopping) press the function selection button once or twice as occasion requires to obtain shopping mode (the shopping mode symbol shown on the display). In this manner the refrigerator reaches its lowest possible temperature to cool down the bigger amount of food.

To exit from shopping mode press the function selection button again. Should you not do so, after a while the refrigerator returns to automatic mode.

Storing in the refrigerator

When placing the different kinds of food take into consideration the sketch below in figure:

1. Confectionery, ready-cooked foods, foods in dishes, fresh meat, cold cuts, drinks
2. Milk, dairy products, foods in dishes
3. Fruits, vegetables, salads
4. Cheese, butter
5. Eggs
6. Yoghurt, sour cream
7. Small bottles, soft drinks
8. Big bottles, drinks

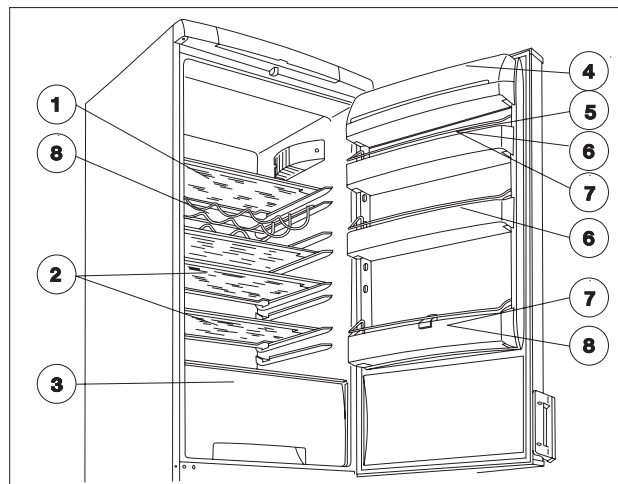

Storage time and temperature of foods

The storage time chart at the end of the instruction book gives information about storage time.

The storage time can not be determined exactly in advance, as it depends on the freshness and handling of the cooled food. That is why the storage time made known is only informative.

If you do not want to use up deep-frozen foods bought immediately they can be stored for about 1 day (until defrosting) in the refrigerator.

Using the freezer

Freezing

The appliance can be used to freeze fresh food of quantity specified on the data label. Freezing different products should always be done after proper preparation as follows.

Press the function selection button once or twice as occasion requires to obtain super freezing mode (the super freezing mode symbol shown on the display).

Put the previously frozen food to another basket or baskets. Put the fresh food into the lower basket, leaving enough space for airflow.

Run the appliance this way for 24 hours.

To exit from super freezing mode press the function selection button again. Should you not do so, after a while the freezer returns to automatic mode.

i **Never freeze food in bigger quantity than given in the 'Technical data' at the same time, otherwise freezing will not be thorough and after dissolving various deterioration may take place (losing taste and aroma, lysing, etc.).**

i Do not make ice during freezing preferably, because making ice reduces freezing capacity.

Storing in the freezer

It is practical to replace frozen products into the basket(s) after freezing has finished. Doing this you could make room in the freezing compartment for another freezing. Intermediate freezing does not deteriorate foods already stored.

In large quantities of food are to be stored, remove the baskets except the lowermost one from appliance and place food on the shelves.

i Do not forget to keep to the storage time given on the packaging of frozen products if you buy them frozen.

i It is safe to store quick-frozen, frozen foods only if they have not dissolved even for a short time until placing them into the freezer. If the deep-frozen food has already dissolved, refreezing is not recommended, it has to be used up as soon as possible.

How to make ice cubes

To make ice cubes fill the enclosed ice cube tray with water and put it to the frozen food compartment. Setting thermostatic control knob to maximum position can shorten preparing time. After finishing do not forget to reset the thermostatic control to the suitable position.

Ready ice cubes can be taken out of the tray under running water then twist or hit it.

Storage time chart (refrigerator)

Time and method of storage of fresh foods in the refrigerator

Foods	Storage time in days							Method of packaging
	1	2	3	4	5	6	7	
Raw meat	X	X	x	x	x			cling film, airtight
Cooked meat	X	X	X	x	x	x		dish covered
Roasted meat	X	X	X	x	x			dish covered
Raw minced meat	X							dish covered
Roasted minced meat	X	X	x	x				dish covered
Cold cuts, Vienna sausage	X	X	x	x				cling film, cellophane, grease-proof paper
Fresh fish	X	x	x					cling film, airtight
Cooked fish	X	X	x	x				dish covered
Fried fish	X	X	x	x	x			dish covered
Tinned fish, open	X	x	x					dish covered
Fresh chicken	X	X	X	x	x	x		cling film, airtight
Fried chicken	X	X	X	x	x	x		dish covered
Fresh hen	X	X	x	x	x			cling film, airtight
Boiled hen	X	X	x	x	x			dish covered
Fresh duck, goose	X	X	X	x	x	x		cling film, airtight
Roasted duck, goose	X	X	X	X	x	x	x	dish covered
Butter unopened	X	X	X	X	X	X	X	original packaging
Butter opened	X	X	x	x	x	x	x	original packaging
Milk in a plastic bag	X	X	X	x	x			original packaging
Cream	X	X	x	x				plastic box
Sour cream	X	X	X	X	x	x	x	plastic box
Cheese (hard)	X	X	X	X	X	X	X	aluminium foil
Cheese (soft)	X	X	X	X	x	x	x	cling film
Curds	X	X	X	X	x	x	x	cling film
Egg	X	X	X	X	X	X	X	
Spinach, sorrel	X	X	x	x				cling film
Green peas, green beans	X	X	X	X	x	x	x	cling film
Mushroom	X	X	x	x	x			cling film
Carrot, roots	X	X	X	X	X	X	X	cling film
Bell-pepper	X	X	x	x	x			cling film
Tomato	X	X	X	X	X	X	X	cling film
Cabbage	X	X	X	X	X	x	x	cling film
Quickly rotting fruits (strawberry, raspberry, etc.)	X	X	X	x	x			cling film
Other fruits	X	X	X	X	x	x	x	cling film
Tinned fruits opened	X	X	X	x	x			dish covered
Cakes filled with cream	X	X	x	x				dish covered

Notation:

X usual storage time

x possible storage time (concerns to really fresh product only)

Storage time chart (freezer)

Storage time of deep-frozen and frozen products

Foods	In the fresh food compartment +2 - +7°C	In the **** frozen food compartment -18°C
Vegetables: green beans, green peas, mixed vegetables, marrow, corn, etc.	1 day	12 months
Ready-cooked foods: vegetable dish, trimmings, with meat, etc.	1 day	12 months
Ready-cooked foods: sirloin steaks,	1 day	6 months
Foods from potatoes, pasta: filled pasta	1 day	12 months
Soups: veg soup	1 day	6 months
Fruits: cherrys	1 day	12 months
Meat: chicken, duck, goose	1 day	5 months
fillets, tuna fish	1 day	6 months
Ice-cream	1 day	3 weeks

Maintenance and Cleaning

 You must disconnect the appliance from the electricity supply, before you can carry out any cleaning or maintenance work.

Defrosting

Freezer

The freezer is Frost Free, defrosting is completely automatic. The defrosted water will flow down a tube located at the back of the appliance to a reservoir located over the compressor (Motor). The heat from the compressor will cause the water in the reservoir to evaporate.

Refrigerator

The defrosting system in the refrigerator is "automatic defrost" The refrigerator will defrost without any intervention from the user.

The thermostat will interrupt the cooling cycle at regular intervals and the temperature of the cooling surfaces will increase to above 0°C and any ice crystals will defrost. Once the temperature of the cooling surfaces reach +3°C to +4°C the thermostat control restarts the cooling cycle. The length of the defrosting cycle will depend on the temperature inside the refrigerator, the quantity of food stored and the room's ambient temperature.

The defrosted water will flow down to a channel located at the bottom of the inside back wall and flow through an outlet to a reservoir located over the compressor (Motor). The heat from the compressor will cause the water in the reservoir to evaporate.

 **Check the outlet on a regular basis to ensure it is clean and no foods or objects are obstructing the flow of water. If the outlet is blocked, water will gather at the bottom of the refrigerator. If the defrosted water seeps into the insulation of the refrigerator this could cause failure of the insulation.**

Clean the water outlet with the pipe cleaner supplied and stored in the outlet.

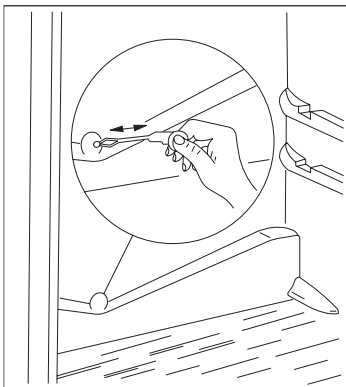

Clean the melting water outlet with the supplied pipe scraper that can be seen in the figure. The pipe scraper has to be stored in the outlet.

The most typical case of clogging up in the melting water outlet when you put food wrapped in some paper into the appliance and this paper contacts back plate of the refrigerator and freezes to it. If you remove the food right at this moment the paper will tear and it can cause clogging up in the outlet by getting into it.

So you are asked to be careful - because of the above - when placing foods wrapped in paper into the appliance.

 It is possible during a heatwave that compressor will operate continuously; during this time the defrosting cycle will not work.

Ice will be seen to a greater degree on the back wall. Once the heatwave has passed the refrigerator will return to normal operations.

Regular cleaning

Disconnect the appliance from the electricity supply, before you carry out any cleaning or maintenance work. Clean the equipment regularly.

 **Don't use detergents, abrasive or strongly odorous cleaners, waxy polishing agents, disinfectants or alcoholic products for cleaning the equipment.**

Pull out the wall plug of the equipment from the outlet.

Internal cleaning

Clean the internal parts of the equipment and the accessories with warm water and Bicarbonate of Soda (5 ml to 0.5 litre of water).

Rinse and dry everything thoroughly.

Clean the door seal profile with clean water.

External cleaning

Clean the external parts of the equipment with warm water and Bicarbonate of Soda (5 ml to 0.5 litre of water).

Dust will build up on the condenser (the black grill at the back of the appliance) and the reservoir; this can inhibit the efficiency of the fridge freezer. It is recommended to clean both on a six monthly basis.

After cleaning, reconnect the equipment to the mains supply.

When the refrigerator is not in use

If the refrigerator is to be turned off for some time, follow these steps.

Unplug the appliance.

Remove foods from the refrigerator.

Defrost and clean it as written before.

Defrost and clean as detailed above.

Trouble shooting

Changing the Light Bulb

Should the light fail to work you can change it as below:

Disconnect the appliance from the electricity supply.

Press the rear hook (1) and at the same time slide the cover in the direction indicated by the arrow (2). So the bulb can be replaced. (Bulb type: T 25 230-240 V, 25 W, E 14 thread)

After changing the bulb replace the cover, snap it in place and plug the appliance back into the mains supply.

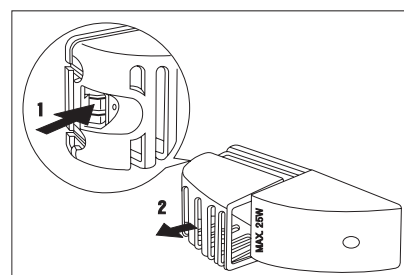

Something Not Working

Certain problems are due to a lack of simple maintenance or oversights, which can be solved easily without calling out an engineer. Please carry out the following checks before contacting the extended warranty administrators see Repairs - After Sales Service.

IMPORTANT: If you call out an engineer to a fault listed below, or to repair a fault caused by incorrect use or installation, a charge will be made even if the appliance is under guarantee.

Symptom	Cause	Solution
<ul style="list-style-type: none"> It is too warm in the refrigerator. 	<ul style="list-style-type: none"> Thermostatic control can be set incorrectly. If products are not cold enough or placed incorrectly. The door does not close tightly or it is not shut properly. 	<ul style="list-style-type: none"> Set the thermostat knob to higher position. Place the products to the appropriate place. Check if the door closes well and the gasket is undamaged and clean.
<ul style="list-style-type: none"> It is too warm in the freezer. 	<ul style="list-style-type: none"> Thermostatic control can be set incorrectly. The door does not close tightly or it is not shut properly. Products in big quantity to be frozen were put in. Products to be frozen are placed too closely to each other. 	<ul style="list-style-type: none"> Set the thermostat knob to higher position. Check if the door closes well and the gasket is undamaged and clean. Wait some hours and then check the temperature again. Place the products in a way so that cold air could circulate among them.
<ul style="list-style-type: none"> Water flows at the back plate of the refrigerator. Water flows into the chamber. Water flows onto the floor. 	<ul style="list-style-type: none"> It is normal. During automatic defrosting frost melts on the back plate. The outlet of the chamber can be clogged up. Products placed in can prevent water from flowing into the collector. The melting water outlet flows not into the evaporative tray above the compressor. 	<ul style="list-style-type: none"> Clean the outlet. Replace the products so that they can not touch the back plate directly. Put the melting water outlet to the evaporative tray.
<ul style="list-style-type: none"> There are too much frost and ice. 	<ul style="list-style-type: none"> Products are not wrapped properly. Doors are not shut properly or do not close tightly. The thermostatic control can be set incorrectly. 	<ul style="list-style-type: none"> Wrap the products better. Check if the doors close well and the gaskets are undamaged and clean. Set the thermostat knob to a position that gives higher temperature.
<ul style="list-style-type: none"> The compressor operates continually. 	<ul style="list-style-type: none"> The thermostatic control is set incorrectly. Doors are not shut properly or do not close tightly. Products in big quantity to be frozen were put in. Too warm food was put in. The appliance is in too warm place. 	<ul style="list-style-type: none"> Set the thermostat knob to a position that gives higher temperature. Check if the doors close well and the gaskets are undamaged and clean. Wait some hours and then check the temperature again. Put food at max. room temperature. Try to reduce the temperature in the room where the appliance stands.
<ul style="list-style-type: none"> The appliance does not work at all. Neither cooling, nor lighting works. 	<ul style="list-style-type: none"> Plug is not connected to the mains socket properly. The fuse burnt out. The thermostatic control is not on. There is no voltage in the mains socket. (Try to connect another appliance into it.) 	<ul style="list-style-type: none"> Connect the mains plug properly. Change the fuse. Start the appliance according to instructions in chapter 'Putting it into use'. Call an electrician.
<ul style="list-style-type: none"> The appliance is noisy. 	<ul style="list-style-type: none"> The appliance is not supported properly. 	<ul style="list-style-type: none"> Check if the appliance stands stable (all the four feet should be on the floor).

In as much as the advice does not lead to result, call the nearest brand-mark service.

Repairs - After Sales Service

In the unlikely event of your appliance requiring service, or if you wish to purchase spare parts, please contact our extended warranty administrators by telephoning:

0870 010 7887

They will give you details for your local Service Force Centre.

Before calling out an engineer, please ensure you have read the details under the heading "Something Not Working".

When you contact your local Service Force Centre you will need to give the following details:

1. Your name, address and post code
2. Your telephone number
3. Clear and concise details of fault
4. The purchase date found on your receipt.
5. The model and serial number of the appliance (found on the rating plate - see picture on page 5)

So that you always have these numbers at hand, we recommend you to make a note of them here:

Mod. :

PNC :

S.N. :

Your Fridge - Freezer is covered by a 3 year parts and labour guarantee (see separate details given at point of sale). Please retain your purchase receipt safely for the service engineer to verify the purchase details.

Spare parts

Always insist on genuine spare parts.

An authorised service engineer should service this product, and only genuine spare parts should be used.

Under no circumstances should you attempt to repair the machine yourself. Repairs carried out by inexperienced persons may cause injury or serious malfunctioning. Contact your local Service Force Centre.

An authorised service engineer always insist on genuine spare parts.

John Lewis Partnership
171 Victoria Street
London SW1E 5NN

www.johnlewis.com

Free Manuals Download Website

<http://myh66.com>

<http://usermanuals.us>

<http://www.somanuals.com>

<http://www.4manuals.cc>

<http://www.manual-lib.com>

<http://www.404manual.com>

<http://www.luxmanual.com>

<http://aubethermostatmanual.com>

Golf course search by state

<http://golfingnear.com>

Email search by domain

<http://emailbydomain.com>

Auto manuals search

<http://auto.somanuals.com>

TV manuals search

<http://tv.somanuals.com>