

JVC



ENGLISH

CD/CASSETTE RECEIVER

KW-XC406/KW-XC405

เครื่องเล่นซีดี/เทปคาสเซต

KW-XC406/KW-XC405

ไทย

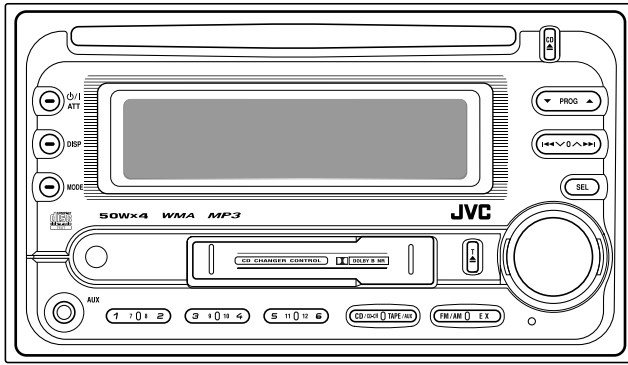
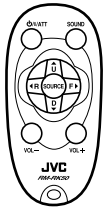

For canceling the display demonstration, see page 8.

ดูที่หน้า 8 เพื่อยกเลิกการสาธิตภาพประกอบ

For installation and connections, refer to the separate manual.

กรุณาดูคู่มือที่แยกต่างหาก ในการติดตั้งและการเชื่อมต่อ

INSTRUCTIONS

คำแนะนำ

GET0327-001A
[U]

Thank you for purchasing a JVC product.

Please read all instructions carefully before operation, to ensure your complete understanding and to obtain the best possible performance from the unit.

IMPORTANT FOR LASER PRODUCTS

1. CLASS 1 LASER PRODUCT
2. **CAUTION:** Do not open the top cover. There are no user serviceable parts inside the unit; leave all servicing to qualified service personnel.
3. **CAUTION:** Visible and invisible laser radiation when open and interlock failed or defeated. Avoid direct exposure to beam.
4. REPRODUCTION OF LABEL: CAUTION LABEL, PLACED OUTSIDE THE UNIT.

CAUTION: Visible and invisible laser radiation when open and interlock failed or defeated. AVOID DIRECT EXPOSURE TO BEAM.	ADVARSEL: Synlig og usynlig laserstråling når maskinen er åben eller interlocken fejler. Undgå direkte eksponering til strålingen.	WARNING: Synlig och osynlig laserstråling när den öppnas och spärren är lurkopplad. Beträkta ej strålen.	VARO: Arvattassa ja suojalukitus ohitettuna tai viallisena olet alittina näkyvälle ja näkymättömälle lasersträlylle. Vältä säteen koholustumista suoraan itseesi. (f)
(e)	(e)	(f)	(s)

Warning:

If you need to operate the unit while driving, be sure to look ahead carefully or you may be involved in a traffic accident.

Caution on volume setting:

Discs produce very little noise compared with other sources. Lower the volume before playing a disc to avoid damaging the speakers by the sudden increase of the output level.

How to reset your unit

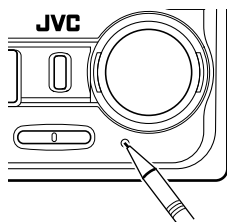

This will reset the microcomputer. Your preset adjustments will also be erased.

How to forcibly eject a disc

If a disc cannot be recognized or cannot be ejected, eject the disc as follows.

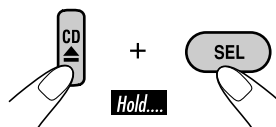

- If this does not work, reset your unit.
- Be careful not to drop the disc when it ejects.

Contents

How to reset your unit	2	Tape operations	17
How to forcibly eject a disc	2	Playing a tape.....	17
How to read this manual	4	Finding the beginning of a tune.....	17
How to use the MODE button	4	Other convenient tape functions	17
Control panel —		Sound adjustments	18
KW-XC406/KW-XC405	5	Selecting preset sound modes	
Parts identification.....	5	(EQ: equalizer).....	18
Remote controller — RM-RK50 ...	6	Adjusting the sound	18
Main elements and features	6	Storing your own sound adjustments.....	19
Getting started.....	7	General settings — PSM	20
Basic operations.....	7	Basic procedure	20
Canceling the display demonstrations ...	8	External component operations... 22	
Setting the clock	8	Playing an external component	22
Radio operations	9	Maintenance	23
Listening to the radio.....	9	Handling discs	23
Storing stations in memory.....	9	Handling cassettes	23
Listening to a preset station	10	More about this unit.....	24
Scanning broadcast stations.....	10	Troubleshooting	27
Assigning titles to the stations	11	Specifications	29
Disc operations	12		
Playing a disc in the unit	12		
Playing discs in the CD changer	13		
Other main functions	15		
Changing the display information	15		
Selecting the playback modes.....	16		

For safety....

- Do not raise the volume level too much, as this will block outside sounds, making driving dangerous.
- Stop the car before performing any complicated operations.





Temperature inside the car....

If you have parked the car for a long time in hot or cold weather, wait until the temperature in the car becomes normal before operating the unit.

How to read this manual

The following methods are used to make the explanations simple and easy-to-understand:

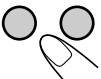
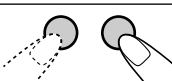
- Some related tips and notes are explained in “More about this unit” (see pages 24 – 26).
- Button operations are mainly explained with the illustrations as follows:

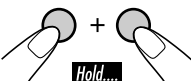
	Press briefly.
	Press repeatedly.
	Press either one.
	
	Press and hold until your desired response begins.
	Press and hold both buttons at the same time.

The following marks are used to indicate...

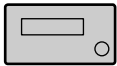

: Built-in CD player operations.



: External CD changer operations.

How to use the MODE button

Press MODE repeatedly to select the different functions available during play.

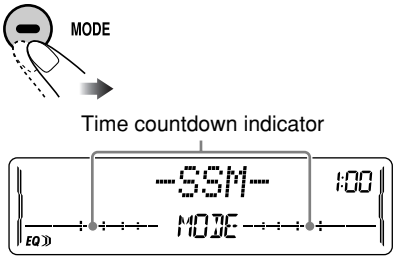

Ex.: When “SSM” is selected

While listening to the radio:

- You cannot select “SSM” or “SCAN” if you are listening to the station stored in the EX (extra) button, see page 10 for details.

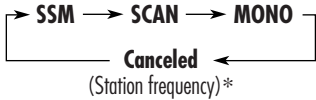

While listening to a disc:

- You cannot select “REPEAT” or “RANDOM” if you are listening to the station stored in the EX (extra) button, see page 10 for details.

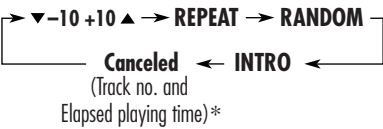

While listening to a tape:

- You cannot select “DOLBY B” or “B.SKIP” if you are listening to the station stored in the EX (extra) button, see page 10 for details.

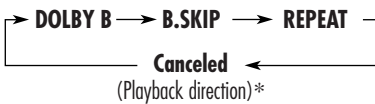

While adjusting the sound mode:

- Pressing MODE allows you to store the adjusted sound mode into memory. (See page 19 for details.)

* Depending on the level meter setting. (See page 20 for details.)

Parts identification

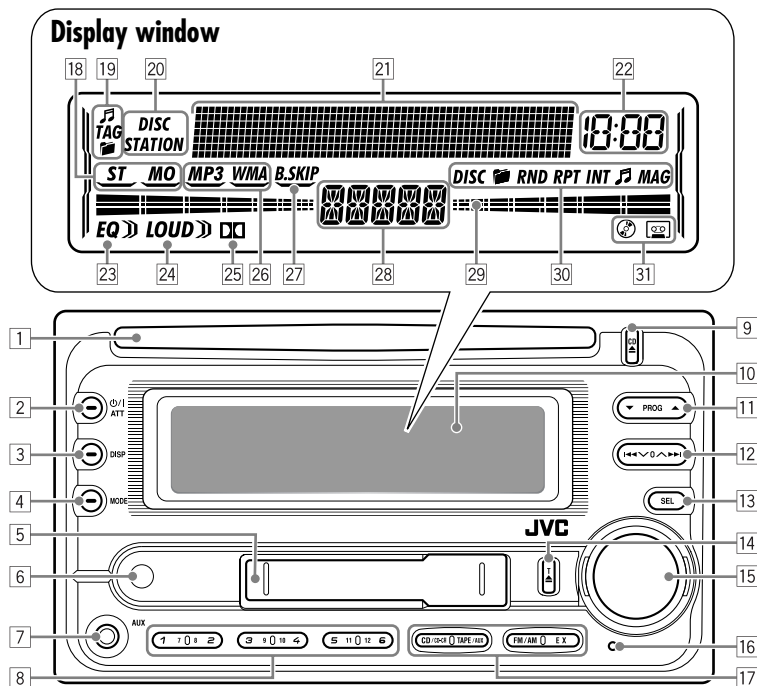

- 1 Loading slot
- 2 ATT (standby/on attenuator) button
- 3 DISP (display) button
- 4 MODE button
- 5 Cassette compartment
- 6 Remote sensor
 - *DO NOT expose the remote sensor to strong light (direct sunlight or artificial lighting).*
- 7 AUX (auxiliary) input jack
- 8 Number buttons
- 9 CD (CD eject) button
- 10 Display window
- 11 (up) / (down) buttons
PROG (program) / buttons
- 12 / buttons
- 13 SEL (select) button
- 14 T (tape eject) button
- 15 Control dial
- 16 Reset button
- 17 Source buttons—CD/CD-CH, TAPE/AUX, FM/AM, EX (extra)

Display window

- 18 Tuner reception indicators—ST (stereo), MO (monaural)
- 19 Disc information indicators— (track/file), TAG (ID3 Tag), (folder)
- 20 Text name indicators—DISC, STATION
- 21 Main display, level meter
- 22 Clock indicator
- 23 EQ (equalizer) indicator
- 24 LOUD (loudness) indicator
- 25 (Dolby B NR) indicator
- 26 Playback disc indicators—MP3, WMA
- 27 B.SKIP (blank skip) indicator
- 28 Source display
- 29 Level meter, volume meter, time countdown indicator
- 30 Playback mode indicators—DISC, (folder), RND (random), RPT (repeat), INT (intro), (track/file), MAG (magazine)
- 31 Loaded source indicators— (disc), (tape)

Installing the lithium coin battery (CR2025)

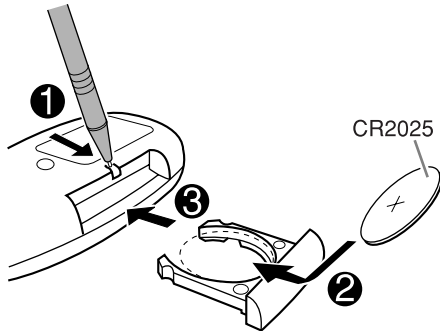

- When operating, aim the remote controller directly at the remote sensor on the unit. Make sure there is no obstacle in between.

Warning:

- Do not install any battery other than CR2025 or its equivalent; otherwise, it may explode.
- Store the battery in a place where children cannot reach to avoid risk of accident.
- To prevent the battery from over-heating, cracking, or starting a fire:
 - Do not recharge, short, disassemble, heat the battery, or dispose of it in a fire.
 - Do not leave the battery with other metallic materials.
 - Do not poke the battery with tweezers or similar tools.
 - Wrap the battery with tape and insulate when throwing away or saving it.

Caution:

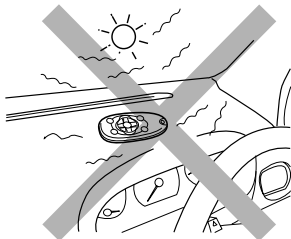

Main elements and features

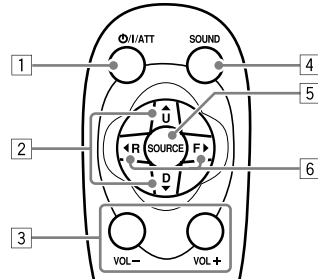

- 1** **⏻/I/ATT** (standby/on/attenuator) button
 - Turns the power on if pressed briefly and attenuates the sound when the power is on.
 - Turns the power off if pressed and held.
- 2** **▲ U** (up) / **D** (down) **▼** buttons
 - Changes the FM/AM bands with **▲ U** only.
 - Changes the preset stations with **D ▼** only.
 - Changes the folder of the MP3/WMA discs.
 - Changes the tape directions with **▲ U** only.
 - While playing an MP3 disc on an MP3-compatible CD changer:
 - Changes the disc if pressed briefly.
 - Changes the folder if pressed and held.
- 3** **VOL - / VOL +** buttons
 - Adjusts the volume level.
- 4** **SOUND** button
 - Selects the sound mode (EQ: equalizer).
- 5** **SOURCE** button
 - Selects the source.
- 6** **◀ R** (reverse) / **F** (forward) **▶** buttons
 - Searches for stations if pressed briefly.
 - Fast-forwards or reverses the track if pressed and held.
 - Changes the tracks of the disc if pressed briefly.
 - Fast-forwards or reverses the tape if pressed and held.*
 - Finds the beginning of a tune (MMS) while listening to a tape if pressed briefly.*

* To release these operations, press **▲ U**. Playback resumes.

Getting started

Basic operations

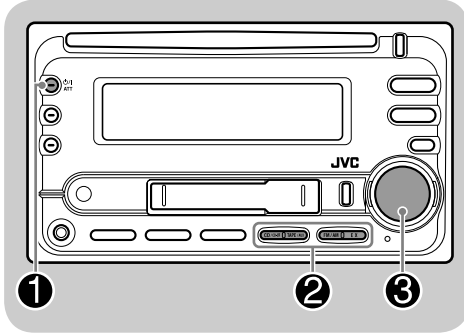

1 Turn on the power.



2 For FM/AM tuner

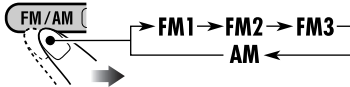

For your favorite station



- Stored your favorite station, see page 10 for details.

For CD/CD-CH



Select "CD-CH" when using an Apple iPod® or a JVC D. player (see page 22).

iPod is a trademark of Apple Computer, Inc., registered in the U.S. and other countries.

For TAPE/AUX



* You cannot select these sources if they are not ready.

3 Adjust the volume.

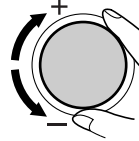

Volume level appears.



Volume level indicator

4 Adjust the sound as you want. (See pages 18 and 19.)

To drop the volume in a moment (ATT)



To restore the sound, press it again.

To turn off the power



Canceling the display demonstrations

If no operations are done for about 20 seconds, display demonstration starts.

[Initial: DEMO ON]—see page 20.

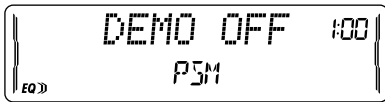
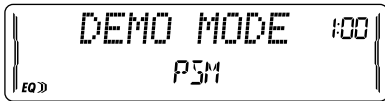
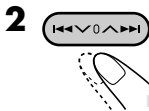

4 Finish the procedure.



To activate the display demonstration

In step 3 above...



Setting the clock



2 Set the hour and minute.

- 1 Select "CLOCK HOUR," then adjust the hour.
- 2 Select "CLOCK MIN," (minute) then adjust the minute.

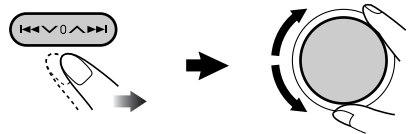

3 Finish the procedure.



Radio operations

Listening to the radio

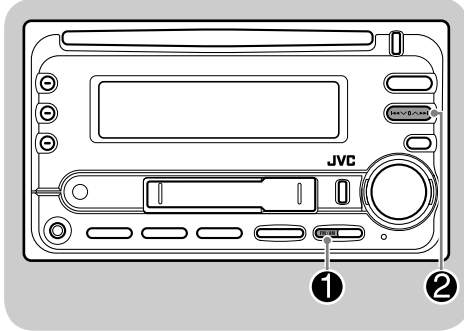

1

FM/AM → FM1 → FM2 → FM3
AM ←

Lights up when receiving an FM stereo broadcast with sufficient signal strength.

Selected band appears.

2 Start searching for a station.

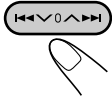

When a station is received, searching stops.

To stop searching, press the same button again.

To tune in to a station manually

In step 2 above...

1

100

Hold...

2 Select the desired station frequencies.

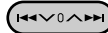

When an FM stereo broadcast is hard to receive

1

MODE → MONO

2

SEL → MONO OFF → MONO ON

Lights up when monaural mode is activated.

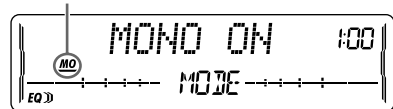

Reception improves, but stereo effect will be lost.

To restore the stereo effect, repeat the same procedure. Then, in step 2, select “MONO OFF.”

Storing stations in memory

You can preset six stations for each band.

FM station automatic presetting—SSM (Strong-station Sequential Memory)

1 Select the FM band (FM1 – FM3) you want to store into.

FM/AM → FM1 → FM2 → FM3
AM ←

To be continued....

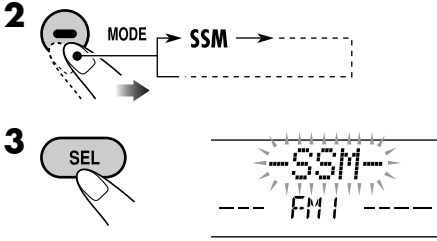

“SSM” flashes, then disappears when automatic presetting is over.

Local FM stations with the strongest signals are searched and stored automatically in the FM band.

Manual presetting

Ex.: Storing FM station of 92.5 MHz into the preset number 4 of the FM1 band.

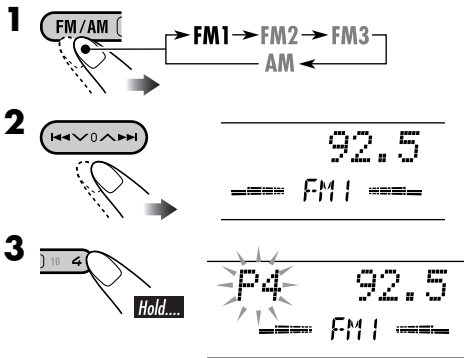

Preset number flashes for a while.

Storing your favorite station into the EX (extra) button

Ex.: Storing your favorite FM station of 92.5 MHz into the EX button

While listening to an FM station, tune in to your favorite station, then....



Listening to a preset station

- 1 Press the MODE button. The display shows 'FM1', 'FM2', 'FM3', and 'AM'.
- 2 Select the preset station (1 – 6) you want.

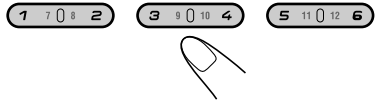

or

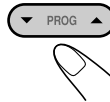

To tune in to your favorite station (EX)



If you press the button again, the previous source will be played back again.

Scanning broadcast stations

- 1 Press the MODE button. The display shows 'SCAN'.
- 2 Start scanning. Press the SEL button. The display shows 'SCAN 92.55' and 'FM1'.

Each time a broadcast is tuned in, scanning stops for about 5 seconds (tuned frequency appears on the display), and you can check what program is now being broadcast.

- 3 Start listening to the program. Press the MODE button.

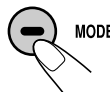

Assigning titles to the stations

You can assign titles to 30 station frequencies (including both FM and AM). Each station name can be assigned up to 10 characters. However, you cannot assign title to the station frequency stored in the EX button.

4 Finish the procedure.



To erase the entire title

In step 3 on the left...



To change the information shown on the display

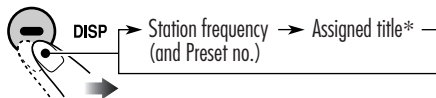

* If no title is assigned, "NO NAME" appears for a while.

1 Tune in to the station you would like to assign a title to.

2 Enter the assigning mode.

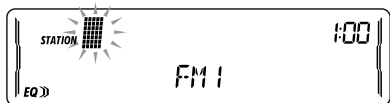

3 Assign a title.

1 Select a character set.

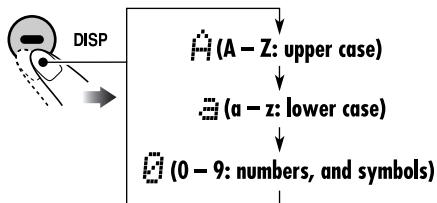

2 Select a character.

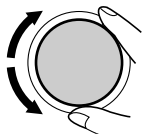

3 Move to the next (or previous) character position.

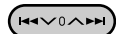

4 Repeat steps 1 to 3 until you finish entering the title.

Available characters

Upper case

A	B	C	D	E	F	G	H	I	J	K	L	M	N
O	P	Q	R	S	T	U	V	W	X	Y	Z	space	

Lower case

a	b	c	d	e	f	g	h	i	j	k	l	m	n
o	p	q	r	s	t	u	v	w	x	y	z	space	

Numbers and symbols

0	1	2	3	4	5	6	7	8	9	!	"	#	\$
%	&	'	()	*	+	,	-	.	/	:	;	<
=	>	?	@	_	`	space							

Disc operations

Playing a disc in the unit

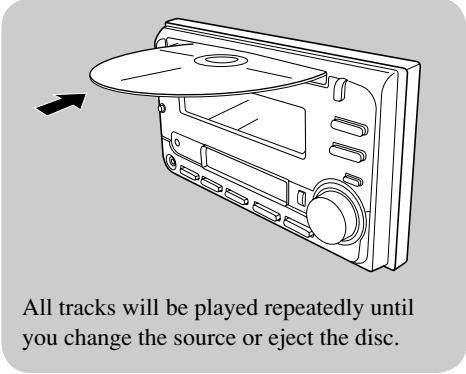

- When inserting an audio CD or a CD Text disc:

Total track number of the inserted disc Total playing time of the inserted disc



**CD Text: Disc title/performer →
Track title appears automatically (see page 15).**

Current track number*2 Elapsed playing time*2

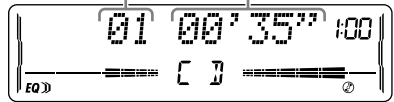

- When inserting an MP3 or a WMA disc:

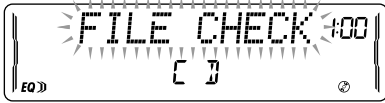

Total folder number Total file number

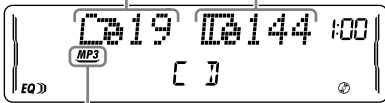

Disc information appears automatically (see page 15).

Current track number*2 Elapsed playing time*2

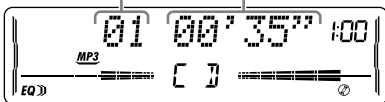

To stop play and eject the disc



The source changes to the last selected source.

*1 Either the MP3 or WMA indicator lights up depending on the detected file.

*2 Depending on the level meter setting. (See page 20 for details.)

Playing discs in the CD changer

1

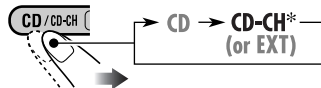

* If you have changed "EXT INPUT" setting to "EXT INPUT" (see page 21), you cannot select the CD changer.
See also page 22 for using iPod or JVC D. player.

2

Select a disc.

For disc number from 01 – 06:



For disc number from 07 – 12:

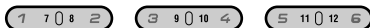

Selected disc number

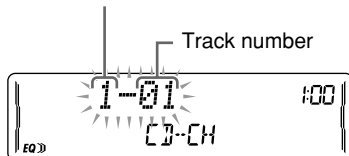

About the CD changer

It is recommended to use a JVC MP3-compatible CD changer with your unit.

- You can also connect other CH-X series CD changers (except CH-X99 and CH-X100). However, they are not compatible with MP3 discs, so you cannot play back MP3 discs.
- You cannot play any WMA disc in the CD changer.
- You cannot use the KD-MK series CD changers with this unit.
- Disc text information recorded in the CD Text can be displayed when a JVC CD Text compatible CD changer is connected.

All tracks of the inserted discs in the magazine will be played repeatedly until you change the source or eject the magazine from the CD changer.

- When the current disc is an MP3 disc:

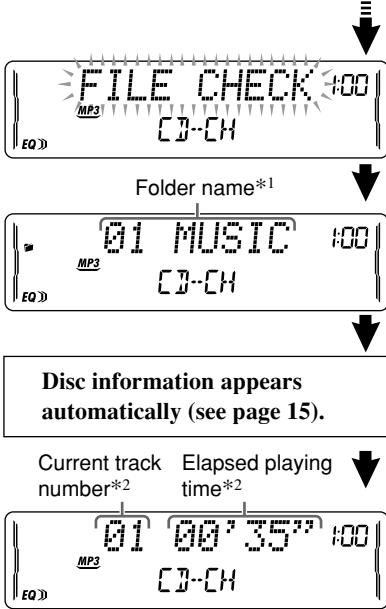

- When the current disc is an audio CD or a CD Text disc:

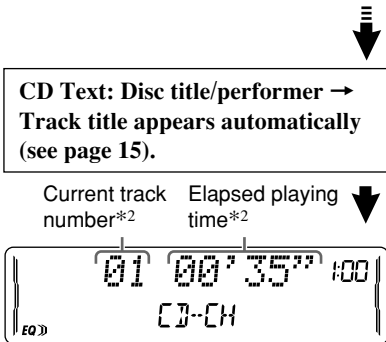

*¹ "ROOT" appears if no folder is included in the disc.

*² Depending on the level meter setting. (See page 20 for details.)

To fast-forward or reverse the track

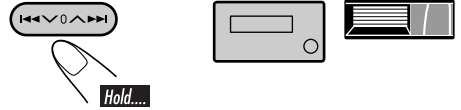

To go to the next or previous tracks

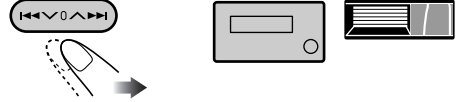

To go to the next or previous folders (for MP3 and WMA discs)

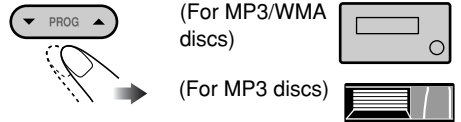

To locate a particular track (for CD) or folder (for MP3 or WMA) discs directly



To select a number from 01 – 06:



To select a number from 07 – 12:



- To use folder search on MP3/WMA discs, it is required that folders are assigned with 2-digit numbers at the beginning of their folder names—01, 02, 03, and so on.

To select a particular track in a folder (for MP3 or WMA disc):

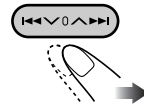

Other main functions

■ Skipping a track quickly during play

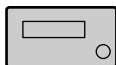

Only possible on JVC
MP3-compatible CD changer

- For MP3 or WMA disc, you can skip a track within the same folder.

Ex.: To select track 32 while playing track 6

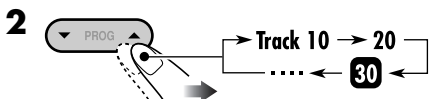
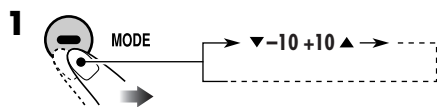

First time you press ▲ / ▼ button, the track skips to the nearest higher or lower track with a track number of multiple ten (ex. 10th, 20th, 30th).

Then each time you press the button, you can skip 10 tracks.

- After the last track, the first track will be selected and vice versa.

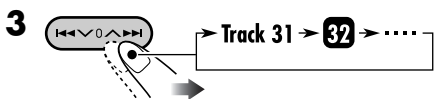

■ Prohibiting disc ejection

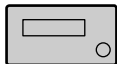

You can lock a disc in the loading slot.



To cancel the prohibition, repeat the same procedure.

Changing the display information

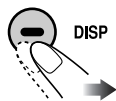

■ While playing an audio CD or a CD Text



■ While playing an MP3 or WMA disc

- When “TAG DISP” is set to “TAG ON” (see page 21)

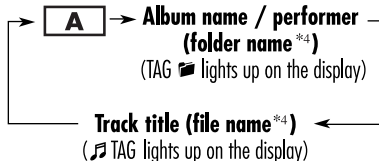

- When “TAG DISP” is set to “TAG OFF”

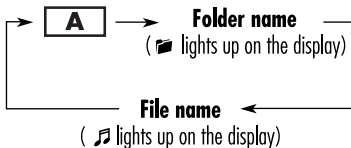

A : Current track/file number and Elapsed playing time

*3 If the current disc is an audio CD, “NO NAME” appears.

*4 If an MP3/WMA file does not have ID3 tags, folder name and file name appear. In this case, the TAG indicator will not light up.

Selecting the playback modes

You can use only one of the following playback modes at a time.

Select your desired playback mode.

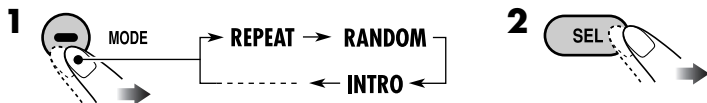

Repeat play

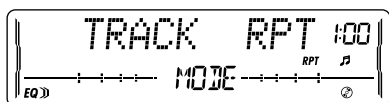

Ex.: When "TRACK RPT" is selected

Mode

Plays repeatedly

- TRACK RPT** : The current track.
 - RPT and light up.
- FOLDER RPT***1: All tracks of the current folder.
 - and RPT light up.
- DISC RPT***2 : All tracks of the current disc.
 - DISC and RPT light up.
- REPEAT OFF** : Cancels.

Random play

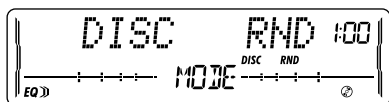

Ex.: When "DISC RND" is selected

Mode

Plays at random

- FOLDER RND***1: All tracks of the current folder, then tracks of the next folder and so on.
 - and RND light up.
- DISC RND** : All tracks of the current disc.
 - DISC and RND light up.
- MAG RND***2 : All tracks of the inserted discs.
 - RND and MAG light up.
- RANDOM OFF** : Cancels.

Intro scan

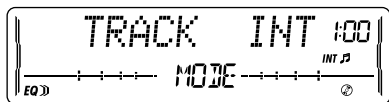

Ex.: When "TRACK INT" is selected

Mode

Plays the beginning 15 seconds of...

- TRACK INT** : All tracks of the current disc.
 - INT and light up.
- FOLDER INT***1 : The first track of every folder of the current disc.
 - and INT light up.
- DISC INT***2 : The first tracks of the inserted discs.
 - DISC and INT light up.
- INTRO OFF** : Cancels.

*1 Only while playing an MP3 disc or WMA disc.

*2 Only while playing discs in the CD changer.

Tape operations

Playing a tape

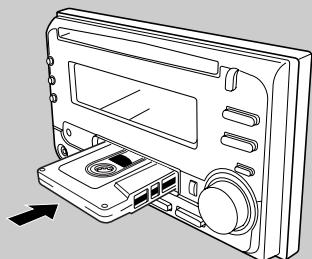

Playback starts automatically. When one side of the tape reaches its end during play, the other side of the tape automatically starts playing. (Auto Reverse)

To change the playback direction



To stop play and eject the cassette



The source changes to the last selected source.

To fast-forward or rewind a tape

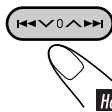

When the tape reaches its end while fast-forwarding, the tape direction will change automatically.

To stop fast-forwarding or rewinding, press the PROG button.

■ Prohibiting tape ejection

You can lock a tape in the loading slot.



To cancel the prohibition, repeat the same procedure.

Finding the beginning of a tune

Multi Music Scan (MMS) allows you to automatically start playback from the beginning of a specified tune.

Specify the tune you want to locate (how many tunes ahead of or before the current tune)

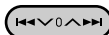

When the beginning of the specified tune is located, playback starts automatically.

MMS -9 <-> MMS -1*3, MMS +1 <-> MMS +9

*3 Goes back to the beginning of the current tune.

Other convenient tape functions

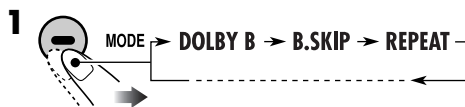

- To turn on or off Dolby B NR*4

DOLBY ON <-> DOLBY OFF
(lights up on the display)

- To skip blank portions on the tape

B.SKIP ON <-> B.SKIP OFF
(B.SKIP lights up on the display)

- To play the current tune repeatedly

REPEAT ON <-> REPEAT OFF
(RPT lights up on the display)

*4 Manufactured under license from Dolby Laboratories. "Dolby" and the double-D symbol are trademarks of Dolby Laboratories.

Sound adjustments

Selecting preset sound modes (EQ: equalizer)

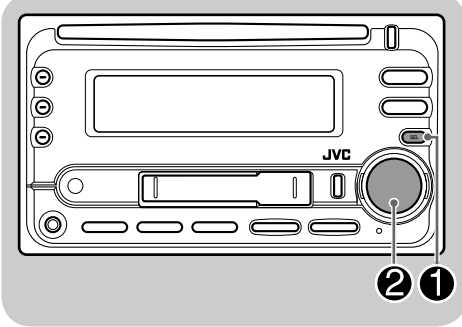

You can select a preset sound mode suitable to the music genre.

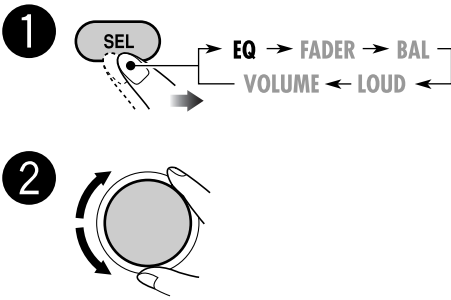

FLAT ⇄ **Hard Rock** ⇄ **R & B** ⇄
POP ⇄ **JAZZ** ⇄ **DanceMusic** ⇄
Country ⇄ **Reggae** ⇄ **Classic** ⇄
USER 1 ⇄ **USER 2** ⇄ **USER 3** ⇄
 (back to the beginning)

To select the sound mode directly

You can select the sound mode directly using the remote controller.

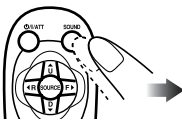

Adjusting the sound

You can adjust the sound characteristics to your preference.

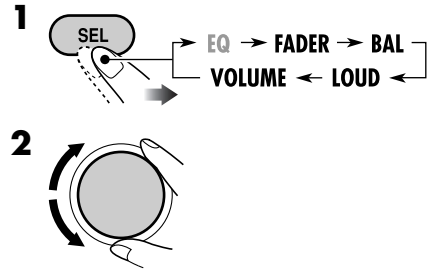

Indication	Range
FADER *1 Adjust the front and rear speaker balance.	R06 (Rear only) to F06 (Front only)
BAL (balance) Adjust the left and right speaker balance.	L06 (Left only) to R06 (Right only)
LOUD (loudness) Boost low and high frequencies to produce a well-balanced sound at low volume level.	LOUD ON ↓ LOUD OFF
VOLUME *2 Adjust the volume.	00 (min.) to 30 or 50 (max.)*3

*1 If you are using a two-speaker system, set the fader level to "00."

*2 Normally the control dial works as the volume control. So you do not have to select "VOLUME" to adjust the volume level.

*3 Depending on the amplifier gain control setting. (See page 21 for details.)

Storing your own sound adjustments

You can adjust the sound modes and store your own adjustments in memory.

4 Adjust the selected sound elements while the indication on step 3 is shown.

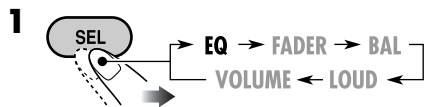
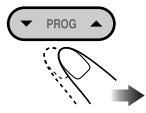

2 Select one of the sound mode to adjust.

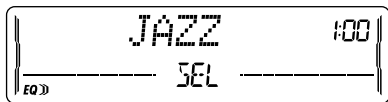
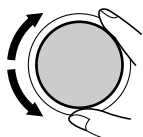

Ex.: When "JAZZ" is selected

3 Select the sound elements to adjust while the selected sound mode is shown.

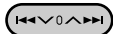

- LOW LEVEL ⇄ LOW FREQ. ⇄
- LOW WIDTH ⇄ MID LEVEL ⇄
- MID WIDTH ⇄ HIGH LEVEL ⇄
- HIGH FREQ. ⇄ (back to the beginning)

- **(LOW, MID, HIGH) LEVEL:**
Adjust the enhancement level.
- **(LOW, HIGH) FREQ:**
Select the center frequency to adjust.
- **(LOW, MID) WIDTH :**
Select the band width level.

Indication	Preset values		
	LOW	MID	HIGH
LEVEL	-06 (min.) to +06 (max.)	-06 (min.) to +06 (max.)	-06 (min.) to +06 (max.)
FREQ	60Hz 80Hz 100Hz 120Hz	—	8kHz 10kHz 12kHz 15kHz
WIDTH	1 (min.) to 4 (max.)	1 (min.) to 2 (max.)	—

5 Repeat steps 3 and 4 to set (or adjust) the other sound elements.

6 Select one of the user sound modes (USER 1, USER 2, USER 3).

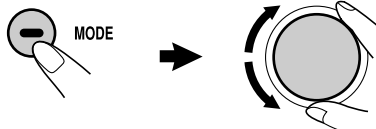

7 Store the adjustments.

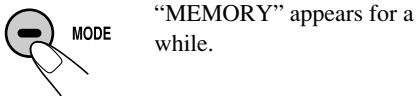

General settings — PSM

Basic procedure

You can change PSM (Preferred Setting Mode) items listed in the table that follows.



2 Select a PSM item.

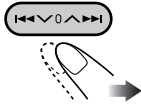

3 Adjust the PSM item selected.

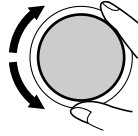

4 Repeat steps 2 and 3 to adjust the other PSM items if necessary.

5 Finish the procedure.



Indications	Selectable settings, [reference page]
DEMO MODE Display demonstration	DEMO ON : [Initial]; Display demonstration will be activated automatically if no operation is done for about 20 seconds, [8]. DEMO OFF : Cancels.
CLOCK HOUR Hour adjustment	1 – 12, [8] [Initial: 1 (1:00)]
CLOCK MIN Minute adjustment	00 – 59, [8] [Initial: 00 (1:00)]
CLOCK DISP Clock display	CLOCK ON : Clock time is shown on the display at all times even when the unit is turned off. CLOCK OFF : [Initial]; Clock time is shown when the unit is turned on. If the unit is turned off, pressing DISP will show the clock time for about 5 seconds.

LEVELMETER
Audio level meter

You can select one of the four different level meter patterns or a demonstration of all the patterns.

LEVEL ALL [Initial] ⇄ **LEVEL 1** ⇄ **LEVEL 2** ⇄ **LEVEL 3** ⇄ **LEVEL 4** ⇄ **LEVEL OFF** (canceled) ⇄ (back to the beginning)

LEVEL ALL : Demonstrates all the level meter patterns, each for about 20 seconds.

LEVEL 1

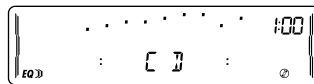

LEVEL 2

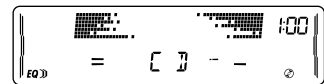

LEVEL 3

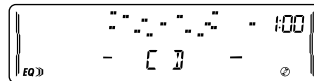

LEVEL 4

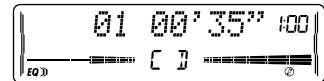

Indications	Selectable settings, [reference page]
DIMMER Dimmer	AUTO : [Initial]; Dims the display when you turn on the headlights.
	ON : Activates dimmer.
	OFF : Cancels.
CONTRAST Display contrast	1 – 10 : Adjust the display contrast to make the display indications clear and legible. [Initial: 5]
SCROLL *1 Scroll	ONCE : [Initial]; Scrolls the disc information once.
	AUTO : Repeats scrolling (5-second intervals in between).
	OFF : Cancels. • Pressing DISP for more than one second can scroll the display regardless of the setting.
EXT INPUT *2 External input	CHANGER : [Initial]; To use a JVC CD changer, an Apple iPod, or a JVC D. player, [13, 22].
	EXT INPUT : To use another external component, [22].
AUX ADJUST Auxiliary input level adjustment	AUX ADJ 00 – AUX ADJ 05: Adjust the auxiliary input level accordingly, to avoid the sudden increase of the output level when changing the source from external component connected to the AUX input jack on the control panel. [Initial: AUX ADJ 00]
TAG DISP Tag display	TAG ON : [Initial]; Shows the ID3 tag while playing MP3/WMA tracks, [15].
	TAG OFF : Cancels.
AMP GAIN Amplifier gain control	You can change the maximum volume level of this unit.
	LOW PWR : VOLUME 00 – VOLUME 30 (Select this if the maximum power of the speaker is less than 50 W to avoid damaging the speaker.)
	HIGH PWR : [Initial]; VOLUME 00 – VOLUME 50
IF FILTER IF filter	AUTO : [Initial]; Increases the tuner selectivity to reduce noise interference between the stations. (Stereo effect will also be lost.)
	WIDE : Subject to noise interference from adjacent stations, but sound quality will not be degraded and will retain the stereo effect.

*1 Some characters or symbols will not be shown (and will be blanked) or substituted on the display.

*2 Cannot be selected if the source is "CD-CH" or "EXT."

External component operations

This unit is ready for any Apple iPod® or JVC D. player control interface.

- For details, refer also to the manual supplied with the interface adapter for iPod®—KS-PD100 or D. player—KS-PD500.

Playing an external component

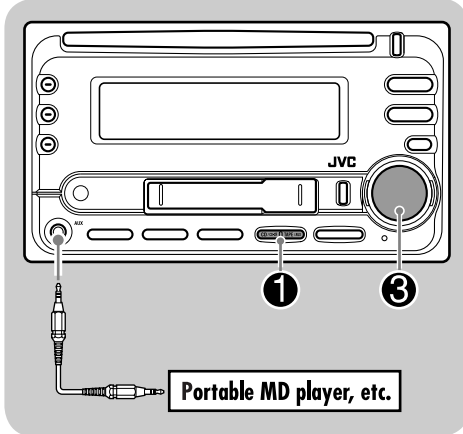

You can connect an external component to....

- CD changer jack on the rear using:
 - Line Input Adapter—KS-U57 or KS-U58 (not supplied) for any other components (except iPod or D. player).
 - Interface adapter for iPod®—KS-PD100 (not supplied) for controlling iPod.
 - D. player interface adapter—KS-PD500 (not supplied) for controlling D. player.
- AUX (auxiliary) input jack on the control panel.

For connection, see Installation/Connection Manual (separate volume).

- 1 For selecting the external component connected to....
 - AUX input jack

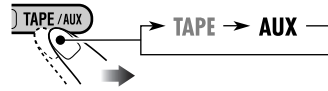

- CD changer jack on the rear using KS-U57 or KS-U58
If “EXT” does not appear, see page 21 and select the external input (EXT INPUT).

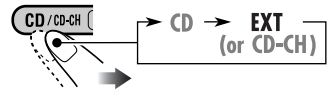

- CD changer jack on the rear using interface adapter for iPod—KS-PD100 or for D. player—KS-PD500

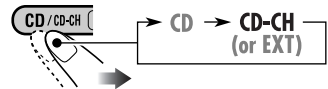

- 2 Turn on the connected component and start playing the source.

- 3 Adjust the volume.



- 4 Adjust the sound as you want. (See pages 18 and 19.)

Handling discs

Moisture condensation

Moisture may condense on the lens inside the CD player in the following cases:

- After starting the heater in the car.
- If it becomes very humid inside the car.

Should this occur, the CD player may malfunction. In this case, eject the disc and leave the unit turned on for a few hours until the moisture evaporates.

How to handle discs

When removing a disc from its case, press down the center holder of the case and lift the disc out, holding it by the edges.

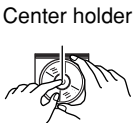

- Always hold the disc by the edges. Do not touch its recording surface.

When storing a disc into its case, gently insert the disc around the center holder (with the printed surface facing up).

- Make sure to store discs into the cases after use.

To keep discs clean

A dirty disc may not play correctly. If a disc does become dirty, wipe it with a soft cloth in a straight line from center to edge.



- Do not use any solvent (for example, conventional record cleaner, spray, thinner, benzene, etc.) to clean discs.

To play new discs

New discs may have some rough spots around the inner and outer edges. If such a disc is used, this unit may reject the disc.



To remove these rough spots, rub the edges with a pencil or ball-point pen, etc.

Do not use the following discs:

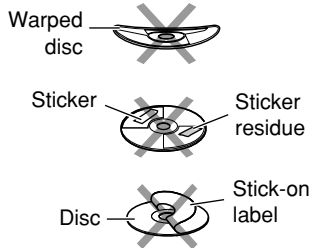

Handling cassettes

To clean the head

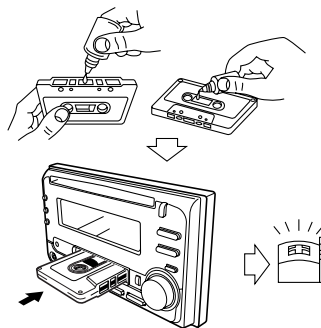

- Clean the heads after every 10 hours of use using a wet-type head cleaning tape (available at an audio store).
When the head becomes dirty, you may realize the following symptoms:
 - Sound quality is reduced.
 - Sound level decreases.
 - Sound drops out.
- Do not touch the highly-polished head with any metallic or magnetic tools.

To keep the tape clean

- Always store the cassettes in their storage cases after use.
- Do not store cassettes in the following places:
 - Subject to direct sunlight
 - With high humidity
 - At extremely hot temperatures

More about this unit

Basic operations

Turning on the power

- By pressing the source buttons on the unit, you can also turn on the power. If the source is ready, playback also starts.

Turning off the power

- If you turn off the ignition key without turning off this unit, the unit will automatically turn on when you turn on the ignition key next time. If the last selected source is ready for playback (ex. a disc or a tape is in the unit), playback starts automatically.
- If you turn off the power while listening to a disc, disc play will start from where playback has been stopped previously, next time you turn on the power.

Selecting the sources

- When no disc or cassette is loaded in the unit, “CD” or “TAPE” cannot be selected.
- Without connecting to the CD changer, “CD-CH” cannot be selected.

Tuner operations

Storing stations in memory

- During SSM search...
 - All previously stored stations are erased and stations are stored newly.
 - Received stations are preset in No. 1 (lowest frequency) to No. 6 (highest frequency).
 - When SSM is over, the station stored in No. 1 will be automatically tuned in.
- When storing a station manually, a previously preset station is erased when a new station is stored in the same preset number.

Disc operations

Caution for DualDisc playback

- The Non-DVD side of a “DualDisc” does not comply with the “Compact Disc Digital Audio” standard. Therefore, the use of Non-DVD side of a DualDisc on this product may not be recommended.

General

- MP3 and WMA (Windows Media® Audio) “tracks” (words “file” and “track” are used interchangeably) are recorded in “folders.”
- This unit has been designed to reproduce CDs/CD Texts, and CD-Rs (Recordable)/CD-RWs (Rewritable) in audio CD (CD-DA), MP3 and WMA format.
- When a disc has been loaded, selecting “CD” for the playback source starts disc play.

Inserting a disc

- When a disc is inserted upside down, the disc automatically ejects and the unit starts playing the last selected source.
- Do not insert 8 cm discs (single CD) and unusual shape discs (heart, flower, etc.) into the loading slot.

Playing a disc

- While fast-forwarding or reversing on an MP3 or WMA disc, you can only hear intermittent sounds.

Playing a CD-R or CD-RW

- Use only “finalized” CD-Rs or CD-RWs.
- This unit can play back only the files of the same type which is first detected if a disc includes both audio CD (CD-DA) files and MP3/WMA files.
- This unit can play back multi-session discs; however, unclosed sessions will be skipped while playing.

- Some CD-Rs or CD-RWs may not play back on this unit because of their disc characteristics, and for the following causes:
 - Discs are dirty or scratched.
 - Moisture condensation occurs on the lens inside the unit.
 - The pickup lens inside the unit is dirty.
 - CD-R/CD-RW on which the files are written with “Packet Write” method.
 - There are improper recording conditions (missing data, etc.) or media conditions (stain, scratch, warp, etc.).
- CD-RWs may require a longer readout time since the reflectance of CD-RWs is lower than that of regular CDs.
- Do not use the following CD-Rs or CD-RWs:
 - Discs with stickers, labels, or protective seal stuck to the surface.
 - Discs on which labels can be directly printed by an ink jet printer.
 Using these discs under high temperatures or high humidity may cause malfunctions or damages to the unit.
- The maximum number of characters for file/folder names vary among the disc format used (includes 4 extension characters—<.mp3> or <.wma>).
 - ISO 9660 Level 1: up to 12 characters
 - ISO 9660 Level 2: up to 31 characters
 - Romeo*: up to 128 (72) characters
 - Joliet*: up to 64 (36) characters
 - Windows long file name*: up to 128 (72) characters
 * *The parenthetic figure is the maximum number of characters for file/folder names in case the total number of files and folders is 313 or more.*
- This unit can recognize the total of 512 files, of 200 folders, and of 8 hierarchies.
- This unit can play back the files recorded in VBR (variable bit rate).
The files recorded in VBR have a discrepancy in elapsed time display, and do not show the actual elapsed time. This difference becomes noticeable especially after performing the search function.

Playing an MP3/WMA disc

- This unit can play back MP3/WMA files with the extension code <.mp3> or <.wma> (regardless of the letter case—upper/lower).
- This unit can show the names of albums, artists (performer), and ID3 Tag (Version 1.0, 1.1, 2.2, 2.3, or 2.4) for MP3 files and for WMA files.
- This unit can display only one-byte characters. No other characters can be correctly displayed (see page 11).
- This unit can play back MP3/WMA files meeting the conditions below:
 - Bit rate: 8 kbps — 320 kbps
 - Sampling frequency:
 - 48 kHz, 44.1 kHz, 32 kHz (for MPEG-1)
 - 24 kHz, 22.05 kHz, 16 kHz (for MPEG-2)
 - 48 kHz, 44.1 kHz, 32 kHz (for WMA)
 - Disc format: ISO 9660 Level 1/ Level 2, Romeo, Joliet, Windows long file name
- This unit cannot play back the following files:
 - MP3 files encoded with MP3i and MP3 PRO format.
 - MP3 files encoded in an unappropriated format.
 - MP3 files encoded with Layer 1/2.
 - WMA files encoded with lossless, professional, and voice format.
 - WMA files which are not based upon Windows Media® Audio.
 - WMA files copy-protected with DRM.
 - Files which have the data such as WAVE, ATRAC3, etc.
- The search function works but search speed is not constant.

To be continued....

Changing the source

- If you change the source, playback also stops (without ejecting the disc). Next time you select “CD” or “CD-CH” for the playback source, disc play starts from where it has been stopped previously.

Ejecting a disc

- If the ejected disc is not removed within 15 seconds, the disc is automatically inserted again into the loading slot to protect it from dust. (Disc will not play this time.)

Tape operations

Playing a tape

- While locating a specified tune:
 - If the tape is rewound to its beginning, playback starts from the beginning of that side.
 - If the tape is fast-forwarded to the end, it is reversed and played from the beginning of the other side.
- In the following cases, Multi Music Scan (MMS), Blank Skip, and Repeat Play may not operate correctly:
 - Tapes with tunes having long pianissimo passages (very quiet parts) or non-recorded portions.
 - Tapes with short non-recorded sections.
 - Tapes with high level noise or humming between tunes.
 - The Dolby NR setting does not match. For example, if the tape is recorded with the Dolby C NR.
- Do not use the following tape:
 - Dirty or dusty tapes.
 - Cassette with peeling labels.
 - Loose tape which may become entangled with the mechanism.

Changing the source

- If you change the source, playback also stops (without ejecting the cassette).

Ignition key-off release

- When you turn off the ignition key with a cassette in the compartment, the unit automatically releases the tape from its head.

General settings—PSM

- If you change the “TAG DISP” setting from “TAG OFF” to “TAG ON” while playing MP3/WMA file, the tag display will be activated when the next file starts playing.
- If you change the “AMP GAIN” setting from “HIGH PWR” to “LOW PWR” while the volume level is set higher than “VOLUME 30,” the unit automatically changes the volume level to “VOLUME 30.”

Other main functions

- If you try to assign a title to the 31st station frequency, “NAME FULL” flashes. Delete unwanted titles before assignment.

Troubleshooting

What appears to be trouble is not always serious. Check the following points before calling a service center.

	Symptoms	Remedies/Causes
General	<ul style="list-style-type: none"> • Sound cannot be heard from the speakers. 	<ul style="list-style-type: none"> • Adjust the volume to the optimum level. • Check the cords and connections.
	<ul style="list-style-type: none"> • The unit does not work at all. 	Reset the unit (see page 2).
FM/AM	<ul style="list-style-type: none"> • SSM automatic presetting does not work. 	Store stations manually.
	<ul style="list-style-type: none"> • Static noise while listening to the radio. 	Connect the antenna firmly.
Disc playback	<ul style="list-style-type: none"> • Disc cannot be played back. 	Insert the disc correctly.
	<ul style="list-style-type: none"> • CD-R/CD-RW cannot be played back. • Tracks on the CD-R/CD-RW cannot be skipped. 	<ul style="list-style-type: none"> • Insert a finalized CD-R/CD-RW. • Finalize the CD-R/CD-RW with the component which you used for recording.
	<ul style="list-style-type: none"> • Disc can be neither played back nor ejected. 	<ul style="list-style-type: none"> • Unlock the disc (see page 15). • Eject the disc forcibly (see page 2).
	<ul style="list-style-type: none"> • Disc sound is sometimes interrupted. 	<ul style="list-style-type: none"> • Stop playback while driving on rough roads. • Use an unscratched disc. • Check the cords and connections.
	<ul style="list-style-type: none"> • “NO DISC” appears on the display. 	Insert a correct disc into the loading slot.
MP3/WMA playback	<ul style="list-style-type: none"> • Disc cannot be played back. 	<ul style="list-style-type: none"> • Use a disc with MP3/WMA tracks recorded in the format compliant with ISO 9660 Level 1, Level 2, Romeo, or Joliet. • Add the extension code <.mp3> or <.wma> to the file names.
	<ul style="list-style-type: none"> • Noise is generated. 	Skip to another track or change the disc. (Do not add the extension code <.mp3> or <.wma> to non-MP3 or WMA tracks.)
	<ul style="list-style-type: none"> • A longer readout time is required (“CHECK” keeps flashing on the display). 	Do not use too many hierarchies and folders.

To be continued....

	Symptoms	Remedies/Causes
MP3/WMA playback	• Tracks do not play back in the order you have intended them to play.	Playback order is determined when the files are recorded.
	• Elapsed playing time is not correct.	This sometimes occurs during play. This is caused by how the tracks are recorded on the disc.
	• “NO FILES” appears on the display.	Insert a disc that contains MP3/WMA tracks.
	• Correct characters are not displayed (e.g. album name).	This unit can only display alphabets (upper/lower case), numbers, and a limited number of symbols.
Tape playback	• A cassette cannot be inserted.	Insert the cassette with the exposed tape facing right.
	• Cassette can be neither played back nor ejected.	Unlock the cassette (see page 17).
	• “NO TAPE” appears on the display.	Insert a cassette correctly.
	• Cassette tapes become hot.	This is not a malfunction.
	• Tape sound is at very low level and sound quality is degraded.	Clean the tape head using a head cleaning tape.
CD changer	• “NO DISC” appears on the display.	Insert a disc into the magazine.
	• “NO MAG” appears on the display.	Insert the magazine.
	• “RESET 8” appears on the display.	Connect this unit and the CD changer correctly and press the reset button of the CD changer.
	• “RESET 1” – “RESET 7” appears on the display.	Press the reset button of the CD changer.
	• The CD changer does not work at all.	Reset the unit (see page 2).

- Microsoft and Windows Media are either registered trademarks or trademarks of Microsoft Corporation in the United States and/or other countries.

Specifications

AUDIO AMPLIFIER SECTION

Maximum Power Output:

Front: 50 W per channel

Rear: 50 W per channel

Continuous Power Output (RMS):

Front: 19 W per channel into 4 Ω , 40 Hz to 20 000 Hz at no more than 0.8% total harmonic distortion.

Rear: 19 W per channel into 4 Ω , 40 Hz to 20 000 Hz at no more than 0.8% total harmonic distortion.

Load Impedance: 4 Ω (4 Ω to 8 Ω allowance)

Equalizer Control Range:

Low: ± 12 dB (60 Hz, 80 Hz, 100 Hz, 120 Hz)

Mid: ± 12 dB

High: ± 12 dB (8 kHz, 10 kHz, 12 kHz, 15 kHz)

Frequency Response: 40 Hz to 20 000 Hz

Signal-to-Noise Ratio: 70 dB

Line-Out Level/Impedance:

2.0 V/20 k Ω load (full scale)

Output Impedance: 1 k Ω

Other terminals: CD changer, AUX (auxiliary) input jack

TUNER SECTION

Frequency Range:

FM: 87.5 MHz to 108.0 MHz

AM: 531 kHz to 1 602 kHz

[FM Tuner]

Usable Sensitivity: 11.3 dBf (1.0 μ V/75 Ω)

50 dB Quieting Sensitivity:

16.3 dBf (1.8 μ V/75 Ω)

Alternate Channel Selectivity (400 kHz): 65 dB

Frequency Response: 40 Hz to 15 000 Hz

Stereo Separation: 30 dB

Capture Ratio: 1.5 dB

[AM Tuner]

Sensitivity: 20 μ V

Selectivity: 35 dB

CD PLAYER SECTION

Type: Compact disc player

Signal Detection System: Non-contact optical pickup (semiconductor laser)

Number of Channels: 2 channels (stereo)

Frequency Response: 5 Hz to 20 000 Hz

Dynamic Range: 96 dB

Signal-to-Noise Ratio: 98 dB

Wow and Flutter: Less than measurable limit

MP3 Decoding Format:

MPEG1/2 Audio Layer 3

Max. Bit Rate: 320 kbps

WMA (Windows Media[®] Audio) Decoding Format:

Max. Bit Rate: 192 kbps

CASSETTE DECK SECTION

Wow and Flutter: 0.1 % (WRMS)

Fast-Wind Time: 100 sec. (C-60)

Frequency Response: 30 Hz to 16 000 Hz (Normal tape)

Signal-to-Noise Ratio: (Normal tape)

Dolby B NR ON: 65 dB

Dolby B NR OFF: 56 dB

Stereo Separation: 40 dB

GENERAL

Power Requirement:

Operating Voltage:

DC 14.4 V (11 V to 16 V allowance)

Grounding System: Negative ground

Allowable Operating Temperature:

0°C to +40°C

Dimensions (W \times H \times D):

Installation Size (approx.):

178 mm \times 100 mm \times 158 mm

Set Size (approx.):

178 mm \times 100 mm \times 175 mm

Mass (approx.):

2.3 kg (excluding accessories)

Design and specifications are subject to change without notice.

Having TROUBLE with operation?

Please reset your unit

Refer to page of How to reset your unit

หากมีปัญหในการใช้งาน
กรุณาดูปุ่มตั้งค่าเริ่มต้นใหม่
กรุณาดูหน้าวิธีตั้งค่าเครื่องใหม่

JVC



EN, TH

© 2005 Victor Company of Japan, Limited

0805DTSMDTJEIN

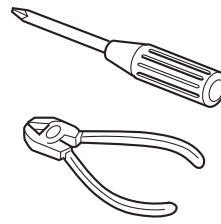

ENGLISH

- This unit is designed to operate on **12 V DC, NEGATIVE ground electrical systems**. If your vehicle does not have this system, a voltage inverter is required, which can be purchased at JVC car audio dealers.

ไทย

- ชุดอุปกรณ์นี้ได้รับการออกแบบมาเพื่อใช้งานกับระบบ กระแสไฟฟ้าชนิดขั้วลบกระแตรง 12 โวลต์ หากรถยนต์ของคุณไม่ได้ใช้ระบบนี้ ต้องใช้เครื่องแปลงกระแสไฟด้วย ซึ่งสามารถหาซื้อได้จากร้านขายเครื่องเสียงรถยนต์ JVC

Parts list for installation and connection

The following parts are provided for this unit.
After checking them, please set them correctly.

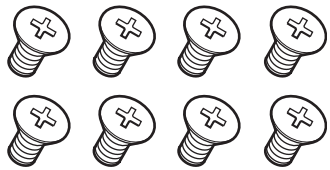

Flat countersunk screws (M5 x 8 mm)
สกรูหัวเรียบ (M5 x 8 มม.)

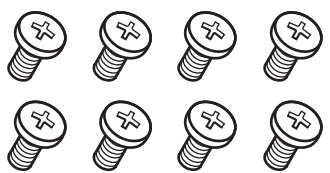

Binding screws (M5 x 8 mm)
สกรูยึด (M5 x 8 มม.)

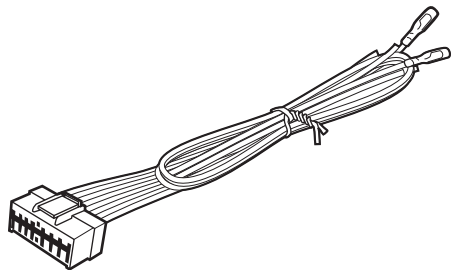

Power cord
สายเคเบิลกำลัง



Battery
แบตเตอรี่



Remote controller
รีโมทคอนโทรล

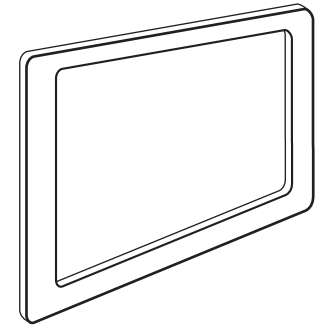

Plate for use with a Nissan car
แผ่นสำหรับใช้กับรถนิสสัน

รายการส่วนประกอบสำหรับติดตั้งและเชื่อมต่อกัน

ส่วนประกอบต่อไปนี้ให้มาพร้อมกับชุดอุปกรณ์นี้ หลังจากตรวจสอบแล้ว โปรดตั้งเครื่องให้ถูกต้อง

When installing the unit in a Nissan car

เมื่อทำการติดตั้งในรถนิสสัน

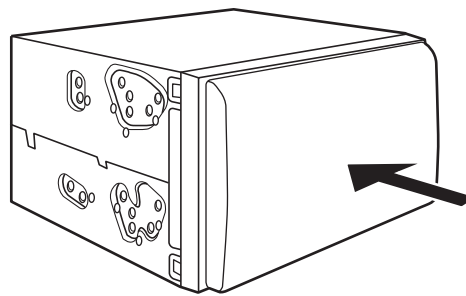

Fix the supplied plate as illustrated
ยึดแผ่นที่มีมาให้ ดังที่แสดงในภาพ

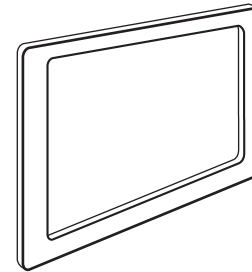
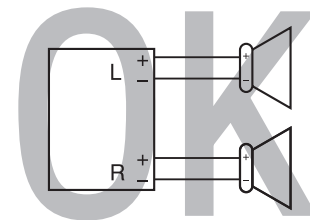
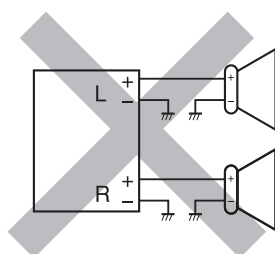
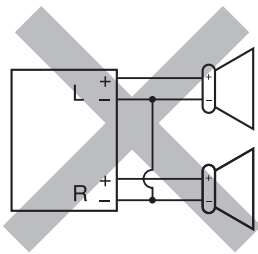

Plate for use with a Nissan car
แผ่นสำหรับใช้กับรถนิสสัน

PRECAUTIONS on power supply and speaker connections:

- DO NOT** connect the speaker leads of the power cord to the car battery; otherwise, the receiver will be seriously damaged.
- BEFORE** connecting the speaker leads of the power cord to the speakers, check the speaker wiring in your car.



ข้อควรระวังสำหรับการต่อแหล่งจ่ายกำลังและลำโพง:

- อย่าต่อสายตะกั่วเคเบิลกำลังของลำโพงเข้ากับแบตเตอรี่รถยนต์ มิฉะนั้น ชุดประกอบจะได้รับความเสียหายมาก
- ก่อนที่จะต่อสายตะกั่วเคเบิลกำลังของลำโพงเข้ากับลำโพง ให้ตรวจสอบการเดินสายไฟลำโพงในรถของคุณให้เรียบร้อยเสียก่อน

TROUBLESHOOTING

- The fuse blows.**
 - Are the red and black leads connected correctly?
- Power cannot be turned on.**
 - Is the yellow lead connected?
- No sound from the speakers.**
 - Is the speaker output lead short-circuited?
- Sound is distorted.**
 - Is the speaker output lead grounded?
 - Are the “-” terminals of L and R speakers grounded in common?
- Noise interfere with sounds.**
 - Is the rear ground terminal connected to the car’s chassis using shorter and thicker cords?
- Unit becomes hot.**
 - Is the speaker output lead grounded?
 - Are the “-” terminals of L and R speakers grounded in common?
- This unit does not work at all.**
 - Have you reset your unit?

การตรวจสอบปัญหาขัดข้อง

- ฟิวส์ขาด**
 - มีการเชื่อมต่อสายตะกั่วสีแดงและสีดำอย่างถูกต้องหรือไม่
- ไม่สามารถเปิดเครื่องได้**
 - มีการเชื่อมต่อสายตะกั่วสีเหลืองหรือไม่
- ไม่มีเสียงออกจากลำโพง**
 - สายตะกั่วส่วนที่ออกจากลำโพงเกิดไฟฟ้าลัดวงจรหรือไม่
- เสียงเพี้ยน**
 - สายตะกั่วส่วนที่ออกจากลำโพงต่อลงดินหรือไม่
 - สายขั้วลบของลำโพงด้านซ้าย (L) และขวา (R) ต่อลงดินตามปกติหรือไม่
- เสียงรบกวน**
 - มีการใช้สายสั้นๆ หรือหนาๆ ต่อจากเครื่องส่วนที่ติดตั้ง ไว้บนพื้นด้านหลังกับตัวถังรถยนต์หรือไม่
- ชุดประกอบร้อนขึ้น**
 - สายตะกั่วส่วนที่ออกจากลำโพงต่อลงดินหรือไม่
 - สายขั้วลบของลำโพงด้านซ้าย (L) และขวา (R) ต่อลงดินตามปกติหรือไม่
- เครื่องรับนี้ทำงานไม่**
 - ท่านได้ตั้งเครื่องใหม่หรือยัง

INSTALLATION (IN-DASH MOUNTING)

The following illustration shows a typical installation. However, you should make adjustments corresponding to your specific car. In this case consult the manual included with the installation kit (option).

In some case, depending of the type and the model of your car, it is not possible to install the unit into the center console.

If you have any questions or require information regarding installation kits, consult your JVC car audio dealer or a company supplying kits.

• If you are not sure how to install this unit correctly, have it installed by a qualified technician.

Before installing the unit

- When mounting the unit, be sure to use the screws provided, as instructed. If other screws are used, there is a possibility that parts could become loose or damaged.
- When tightening screws or bolts be careful not to pinch any connection cord.

การติดตั้ง (การประกอบแผงหน้าปัทม์เข้า)

ภาพตัวอย่างต่อไปนี้แสดงการติดตั้งแบบทั่วไป อย่างไรก็ตามคุณควรทำตามคำแนะนำของรถคุณ ในกรณีดังกล่าวโปรดติดต่อขอคำแนะนำจากตัวแทนจำหน่ายเครื่องเสียง JVC หรือบริษัทที่จัดจำหน่ายชุดประกอบ (อุปกรณ์เสริม)

ในบางกรณี ขึ้นอยู่กับชนิดและรุ่นของรถยนต์ เพราะอาจติดตั้งเครื่องไว้ที่ตำแหน่งคอนโซลกลางไม่ได้

หากคุณมีข้อสงสัยหรือต้องการข้อมูลเพิ่มเติมเกี่ยวกับชุดประกอบ โปรดติดต่อตัวแทนจำหน่ายเครื่องเสียงรถยนต์ JVC หรือบริษัทที่จัดจำหน่ายชุดประกอบ

• หากคุณไม่มั่นใจในวิธีการติดตั้งเครื่องเสียงอย่างถูกวิธี โปรดให้ช่างผู้ชำนาญทำการติดตั้งเท่านั้น

ก่อนการติดตั้งตัวเครื่อง

- เมื่อจะทำการติดตั้งตัวเครื่อง โปรดใช้สกรูที่แนบมาตามที่แนะนำ หากคุณยึดเครื่องด้วยสกรูแบบอื่น อาจทำให้ชิ้นส่วนหลวมหรือเกิดความเสียหายได้
- เมื่อจะขันแน่นสกรูหรือสลักเกลียว ต้องระวังไม่ให้หนีบสายเชื่อมต่อ

1 Remove the audio system originally installed together with the mounting brackets.
Note: Be sure to keep all the screws and parts removed from your car for future use.

2 Attach the mounting brackets (removed from the car), to this unit (see below).

3 Connect the wires (see diagram A).

4 Fix this unit to the car using the screws removed in step 1.
• See "Caution" below.

The following example shown is for installation in a Toyota. For more details, consult your JVC car audio dealer.

1 ถอดลำโพงที่ประกอบเข้าไปกับแท่นรองรับ

หมายเหตุ: โปรดเก็บสกรูและชิ้นส่วนทั้งหมดที่ถอดออกไว้ใช้งานในคราวต่อไป

2 ประกอบแท่นรองรับ (ที่ถอดออกจากรถ) เข้ากับตัวเครื่อง (โปรดดูด้านล่าง)

3 ต่อสายไฟ (โปรดดูแผนผัง A)

4 ยึดตัวเครื่องเข้ากับรถด้วยสกรูที่ถอดออกในขั้นตอนที่ 1

• โปรดอ่าน "ข้อควรระวัง" ด้านล่าง

ตัวอย่างต่อไปนี้เป็นการติดตั้งเครื่องรับสัญญาณในรถยนต์โตโยต้า สำหรับรายละเอียดเพิ่มเติม โปรดติดต่อขอคำแนะนำได้จากตัวแทนจำหน่ายเครื่องเสียงรถยนต์ JVC

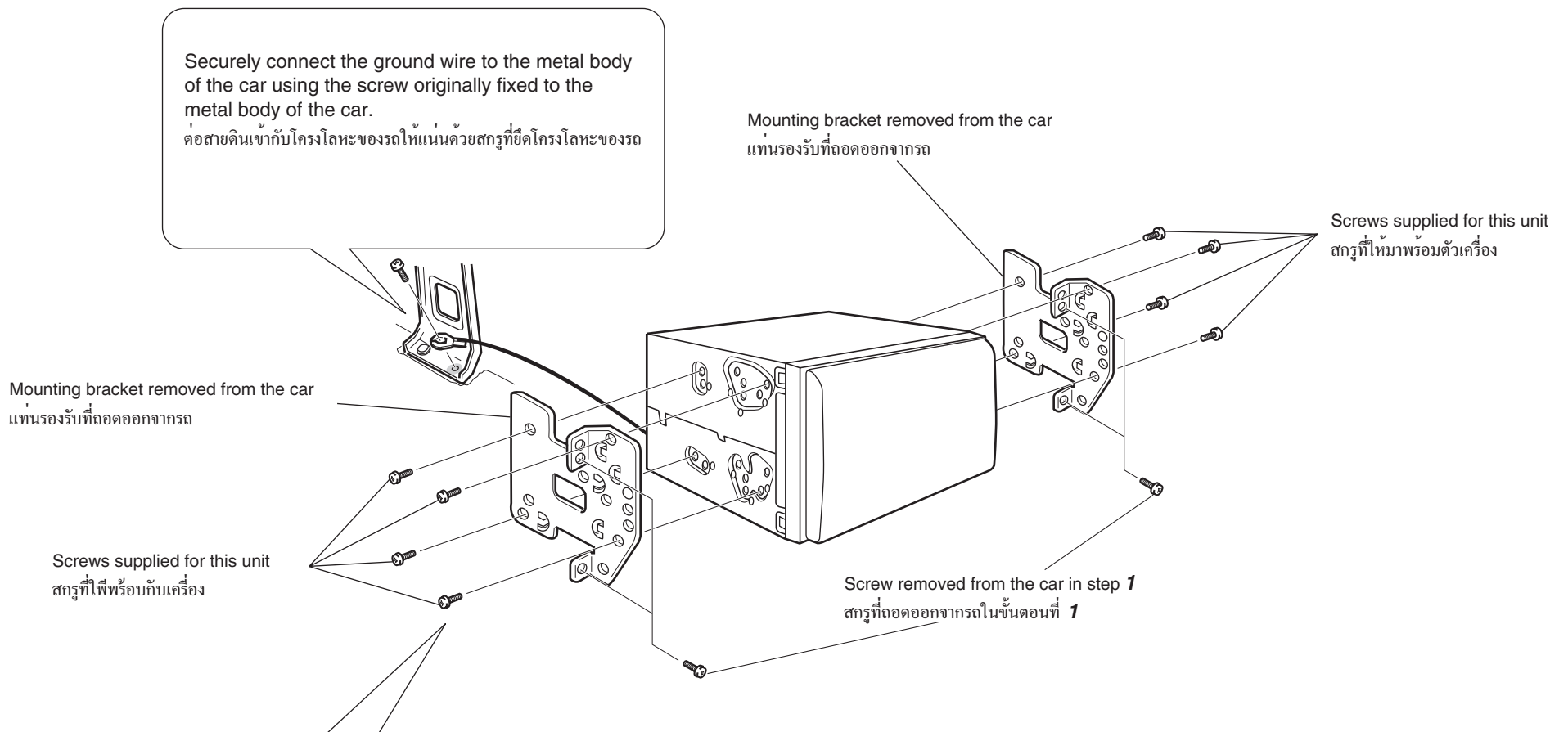

Screws supplied for this unit:

สกรูที่ไฟพร้อมทั้งเครื่อง:

Select the proper screw type, fitting to your car.
เลือกใช้ชนิดสกรูให้เหมาะสมกับรถของคุณ

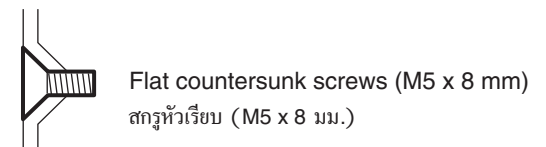
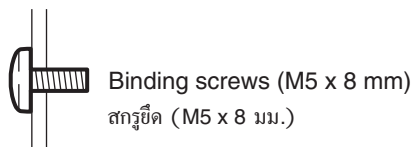

Caution:

To install the mounting brackets to the unit, use only the supplied screws (M5 x 8 mm). If you use any screw longer than 8 mm, the unit can be damaged.

ข้อควรระวัง:

ในการประกอบแท่นรองรับกับตัวเครื่อง โปรดใช้สกรู (M5 x 8 มม.) ที่ให้มาเท่านั้น หากคุณใช้สกรูที่ยาวกว่า 8 มม. อาจทำให้ตัวเครื่องได้รับความเสียหาย

If there is an interfering tab on the mounting bracket, bent it flat.
หากมีส่วนที่ยื่นออกมาจากแท่นรองรับ ให้ดัดส่วนดังกล่าวให้ราบลง

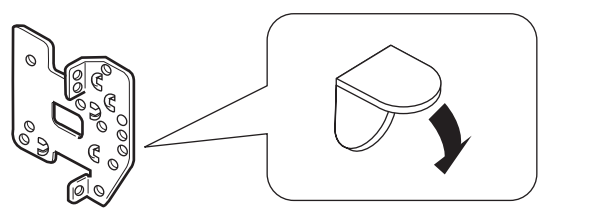

Install the unit at an angle of less than 30°.
ติดตั้งชุดประกอบที่มุมต่ำกว่า 30 องศา

Less than 30°
ต่ำกว่า 30 องศา

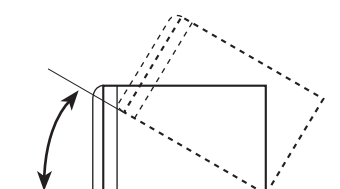

ELECTRICAL CONNECTIONS

To prevent short circuits, we recommend that you disconnect the battery's negative terminal and make all electrical connections before installing the unit.

- Be sure to ground this unit to the car's chassis again after installation.

Notes:

- Replace the fuse with one of the specified rating. If the fuse blows frequently, consult your JVC car audio dealer.
- If noise is a problem...
This unit incorporates a noise filter in the power circuit. However, with some vehicles, clicking or other unwanted noise may occur. If this happens, connect the unit's **rear ground terminal** to the car's chassis using shorter and thicker cords, such as copper braiding or gauge wire. If noise still persists, consult your JVC car audio dealer.
- It is recommended to connect to the speakers with maximum power of more than 50 W (both at the rear and at the front, with an impedance of **4 Ω to 8 Ω**). If the maximum power is less than 50 W, change "AMP GAIN" setting to prevent the speakers from being damaged (see page 21 of the INSTRUCTIONS).
- The heat sink becomes very hot after use. Be careful not to touch it when removing this unit.

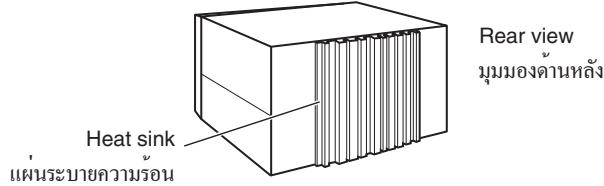

การเชื่อมต่อใช้ไฟฟ้า

เพื่อป้องกันการเกิดไฟฟ้าลัดวงจร ขอแนะนำให้ปลดขั้วแบตเตอรี่ลบออก แล้วจึงต่อสายไฟก่อนติดตั้งเครื่อง

- ตรวจสอบให้แน่ใจว่าได้เดินสายดินต่อระหว่างเครื่องกับตัวถัง รถยนต์ใหม่แล้วหลังจากติดตั้ง

หมายเหตุ:

- ใช้ฟิวส์เฉพาะแทนฟิว หากฟิวส์ขาดบ่อย ให้ปรึกษาช่างขายเครื่องเสียงรถยนต์ JVC
- หากมีเสียงรบกวน...
เครื่องรับสัญญาณรุ่นนี้ได้ประกอบอุปกรณ์กำจัดเสียงรบกวนไว้ที่แผงวงจร อย่างไรก็ตาม ในรถยนต์บางรุ่นอาจมีเสียงรบกวนเกิดขึ้น หากเกิดเสียงดังกล่าวนั้น ให้ต่อขั้วต่อสายดินด้านหลังของตัวเครื่อง ไปที่แชสซีของรถโดยใช้สายไฟที่หนามากขึ้นและสั้นลงเช่น สายเกจหรือลวดถักชุบทองแดง หากยังมีเสียงรบกวนดังกล่าวก่อเกิดขึ้น โปรดติดต่อตัวแทนจำหน่ายเครื่องเสียงรถยนต์ JVC
- ขอแนะนำให้ต่อลำโพง ที่มีกำลังขั้วสูงสุดเกินกว่า 50 W (ทั้งด้านหน้าและด้านหลัง มีค่าความต้านทาน **4 Ω ถึง 8 Ω**) ถ้ากำลังขั้วต่ำกว่า 50 W ให้เปลี่ยนค่า "AMP GAIN" เพื่อป้องกันไม่ให้ลำโพงชำรุด (ดูหน้า 21 คำแนะนำ)
- แผนระบายนความร้อนจะร้อนมากหลังจากใช้ ระดับระงับอย่าไป สัมผัสเมื่อถอดชุดประกอบนี้

A Typical Connections / การเชื่อมต่อแบบปกติ

Before connecting: Check the wiring in the vehicle carefully. Incorrect connection may cause serious damage to this unit.

- 1 Connect the colored leads of the power cord in the order specified in the illustration below.
- 2 Connect the antenna cord.
- 3 Finally connect the wiring harness to the unit.

ก่อนทำการเชื่อมต่อ: ตรวจสอบการเดินสายไฟในรถอย่างละเอียดอย่างระมัดระวังอย่าให้ผิดพลาดใด ๆ การเชื่อมต่อที่ผิดพลาดอาจทำให้เกิดความเสียหายร้ายแรงต่อชุดประกอบ

- 1 ต่อสายไฟตามลำดับที่ระบุในรูปด้านล่าง
- 2 เชื่อมต่อกับสายอากาศ
- 3 สุดท้าย ต่อส่วนควบคุมการเดินสายไฟเข้ากับชุดประกอบชุดนี้

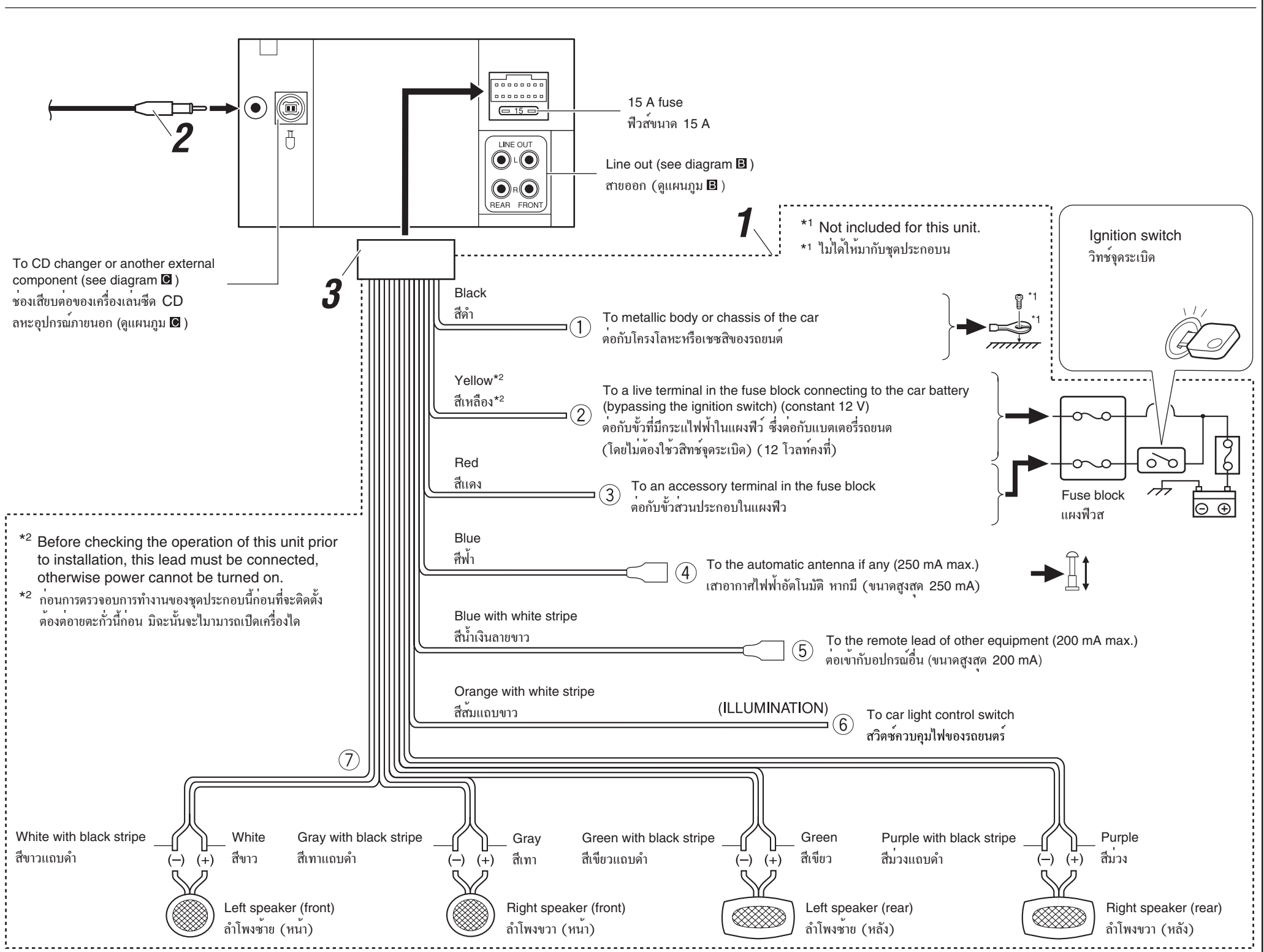

B Connecting the external amplifiers / การต่อเพิ่มเติมเข้ากับอุปกรณ์อื่น

You can connect an amplifier to upgrade your car stereo system.

- Connect the remote lead (blue with white stripe) to the remote lead of the other equipment so that it can be controlled through this unit.
- **Disconnect the speakers from this unit, connect them to the amplifier. Leave the speaker leads of this unit unused.**

คุณสามารถต่อกับแอมพลิฟายเออร์ และอุปกรณ์อื่น ๆ ได้ เพื่อเพิ่มคุณภาพเสียงให้กับระบบสเตอริโอของรถยนต์

- ต่อสายตะกั่วระยะไกล (สีน้ำเงินลายขาว) เข้ากับสายตะกั่วระยะไกลของอุปกรณ์อื่น ๆ เพื่อจะสามารถควบคุมโดยชุดประกอบนี้ได้
- **ถอดลำโพงออกจากชุดประกอบนี้ แล้วต่อเข้ากับเครื่องขยาย ที่ยังตะกั่วลำโพงของชุดประกอบนี้ไว้**

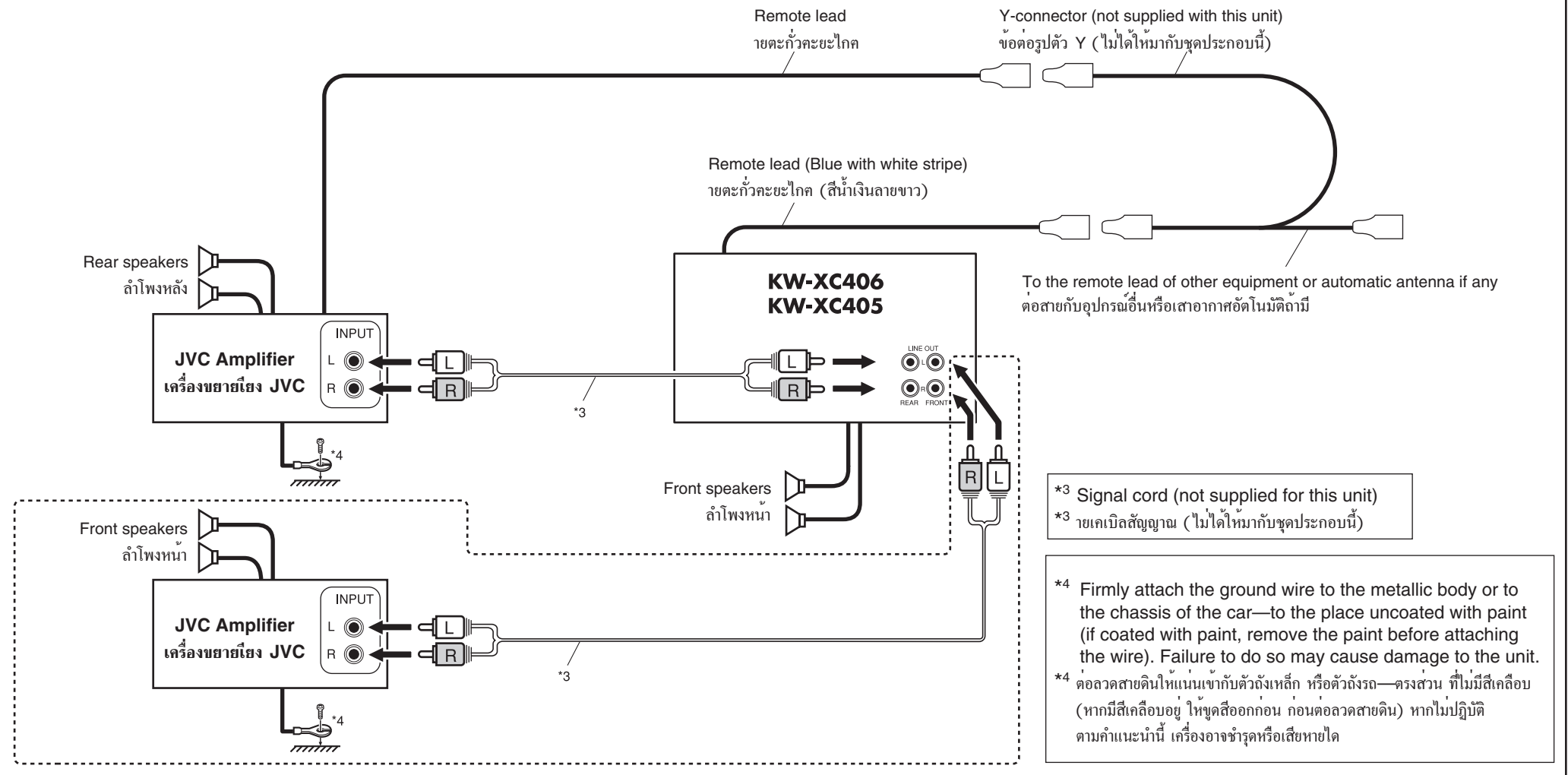

C Connecting the external components / การต่อเพิ่มเติมเข้ากับอุปกรณ์อื่นๆ

- Set "EXT INPUT" to "CHANGER" (see page 21 of the INSTRUCTIONS) / ตั้งค่า "EXT INPUT" เป็น "CHANGER" (ดูหน้า 21 คำแนะนำ)

CD Changer / เซนเจอร์ CD

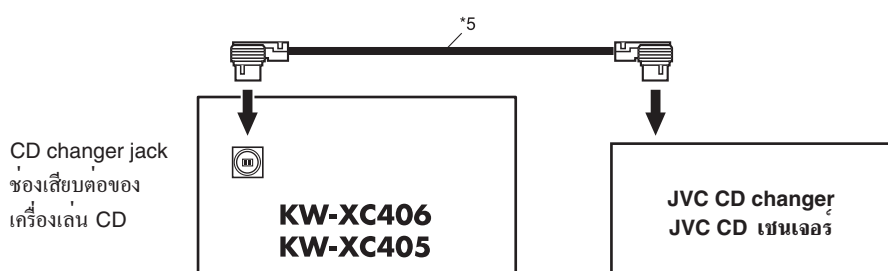

CAUTION / ข้อควรระวัง:

- Before connecting the CD changer, make sure the unit is turned off.
- ก่อนจะเชื่อมต่อ CD เซนเจอร์ กรุณาตรวจสอบให้แน่ใจว่าปิดเครื่องอยู่

*5 Connecting cord supplied for your CD changer

*5 ต่อสายที่ให้มาสำหรับ CD เซนเจอร์

Apple iPod® or JVC D. player / Apple iPod® หรือเครื่องเล่น JVC D

You can connect an iPod or a D. player using an interface adapter (not supplied)—KS-PD100 (for iPod) or KS-PD500 (for D. player).

คุณสามารถเชื่อมต่อกับ iPod หรือเครื่องเล่น D. ด้วยอินเทอร์เฟซอะแดปเตอร์ (ไม่มีมาให้)—KS-PD100 (สำหรับ iPod) หรือ KS-PD500 (สำหรับเครื่องเล่น D.)

iPod is a trademark of Apple Computer, Inc., registered in the U.S. and other countries.

iPod เป็นเครื่องหมายการค้าของ Apple Computer, Inc. ซึ่งจดทะเบียนการค้าในประเทศสหรัฐอเมริกาและประเทศอื่นๆ

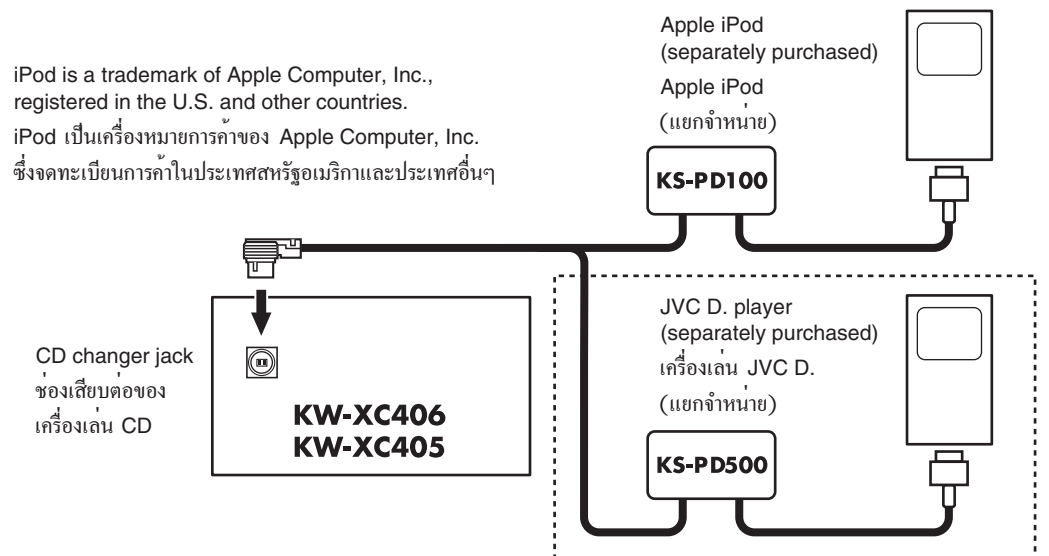

- Set "EXT INPUT" to "EXT INPUT" (see page 21 of the INSTRUCTIONS) / ตั้งค่า "EXT INPUT" เป็น "EXT INPUT" (ดูหน้า 21 คำแนะนำ)

External Component / อุปกรณ์ภายนอก

You can connect an external component using a line input adapter, KS-U57 or KS-U58 (not supplied).

คุณสามารถต่ออุปกรณ์เสริมเพิ่มเติมโดยใช้อะแดปเตอร์รับสัญญาณเข้า (Line input adapter) KS-U57 หรือ KS-U58 (ไม่มีมาให้)

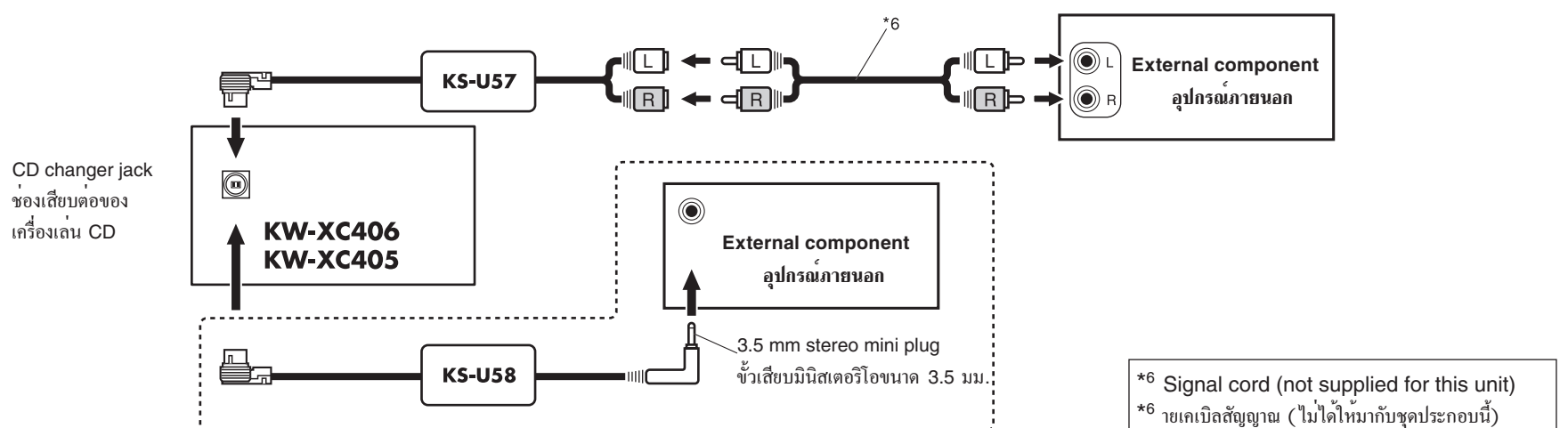

JVC



CD/CASSETTE RECEIVER

KW-XC404

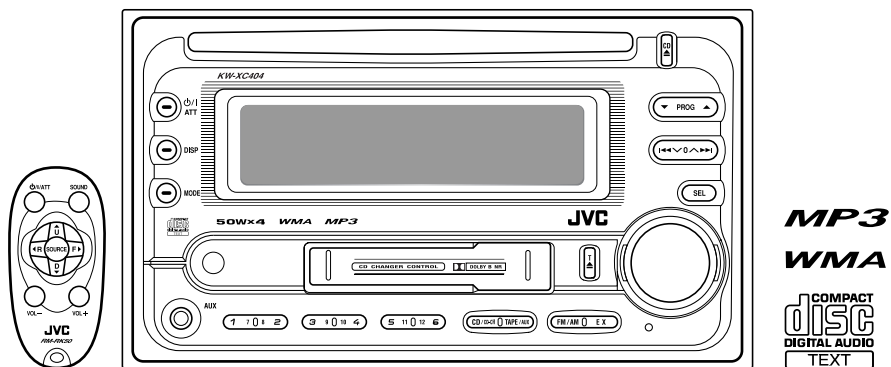

For canceling the display demonstration, see page 8.

For installation and connections, refer to the separate manual.

INSTRUCTIONS

GET0328-001A
[U]

Thank you for purchasing a JVC product.

Please read all instructions carefully before operation, to ensure your complete understanding and to obtain the best possible performance from the unit.

IMPORTANT FOR LASER PRODUCTS

1. CLASS 1 LASER PRODUCT
2. **CAUTION:** Do not open the top cover. There are no user serviceable parts inside the unit; leave all servicing to qualified service personnel.
3. **CAUTION:** Visible and invisible laser radiation when open and interlock failed or defeated. Avoid direct exposure to beam.
4. REPRODUCTION OF LABEL: CAUTION LABEL, PLACED OUTSIDE THE UNIT.

CAUTION: Visible and invisible laser radiation when open and interlock failed or defeated. AVOID DIRECT EXPOSURE TO BEAM.	ADVARSEL: Synlig og usynlig laserstråling når maskinen er åben eller interlocken fejler. Undgå direkte eksponering til strålingen.	VARNING: Synlig og usynlig laserstråling når den åbnes og spærren er lurkopplad. Betrækt ej strålen.	VARO: Arvattassa ja suojalukitus ohitettuna tai viallisena olet alttiina näkyvälle ja näkymättömälle lasersträlylle. Vältä säteen kohollistamista suoraan itseesi. (†)
--	---	---	---

Warning:

If you need to operate the unit while driving, be sure to look ahead carefully or you may be involved in a traffic accident.

Caution on volume setting:

Discs produce very little noise compared with other sources. Lower the volume before playing a disc to avoid damaging the speakers by the sudden increase of the output level.

How to reset your unit

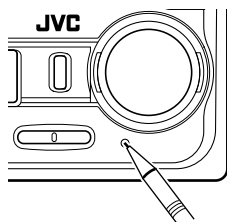

This will reset the microcomputer. Your preset adjustments will also be erased.

How to forcibly eject a disc

If a disc cannot be recognized or cannot be ejected, eject the disc as follows.

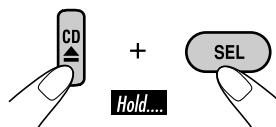

- If this does not work, reset your unit.
- Be careful not to drop the disc when it ejects.

Contents

How to reset your unit	2	Tape operations	17
How to forcibly eject a disc	2	Playing a tape.....	17
How to read this manual	4	Finding the beginning of a tune.....	17
How to use the MODE button	4	Other convenient tape functions	17
Control panel — KW-XC404.....	5	Sound adjustments	18
Parts identification.....	5	Selecting preset sound modes	
Remote controller — RM-RK50 ...	6	(EQ: equalizer).....	18
Main elements and features	6	Adjusting the sound	18
Getting started.....	7	Storing your own sound adjustments.....	19
Basic operations.....	7	General settings — PSM	20
Canceling the display demonstrations ...	8	Basic procedure	20
Setting the clock	8	External component operations... 22	
Radio operations	9	Playing an external component	22
Listening to the radio.....	9	Maintenance	23
Storing stations in memory.....	9	Handling discs	23
Listening to a preset station	10	Handling cassettes	23
Scanning broadcast stations.....	10	More about this unit.....	24
Assigning titles to the stations	11	Troubleshooting	27
Disc operations	12	Specifications	29
Playing a disc in the unit	12		
Playing discs in the CD changer	13		
Other main functions	15		
Changing the display information	15		
Selecting the playback modes.....	16		

For safety....

- Do not raise the volume level too much, as this will block outside sounds, making driving dangerous.
- Stop the car before performing any complicated operations.



Temperature inside the car....

If you have parked the car for a long time in hot or cold weather, wait until the temperature in the car becomes normal before operating the unit.

How to read this manual

The following methods are used to make the explanations simple and easy-to-understand:

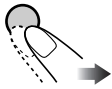
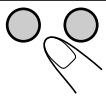
- Some related tips and notes are explained in “More about this unit” (see pages 24 – 26).
- Button operations are mainly explained with the illustrations as follows:

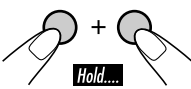
	Press briefly.
	Press repeatedly.
	Press either one.
	
	Press and hold until your desired response begins.
	Press and hold both buttons at the same time.

The following marks are used to indicate...

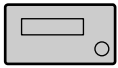

: Built-in CD player operations.



: External CD changer operations.

How to use the MODE button

Press MODE repeatedly to select the different functions available during play.

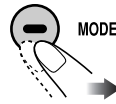

Time countdown indicator



Ex.: When “SSM” is selected

While listening to the radio:

- You cannot select “SSM” or “SCAN” if you are listening to the station stored in the EX (extra) button, see page 10 for details.

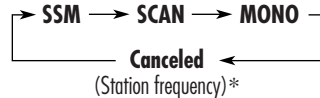

While listening to a disc:



While listening to a tape:



While adjusting the sound mode:

- Pressing MODE allows you to store the adjusted sound mode into memory. (See page 19 for details.)

* Depending on the level meter setting. (See page 20 for details.)

Parts identification

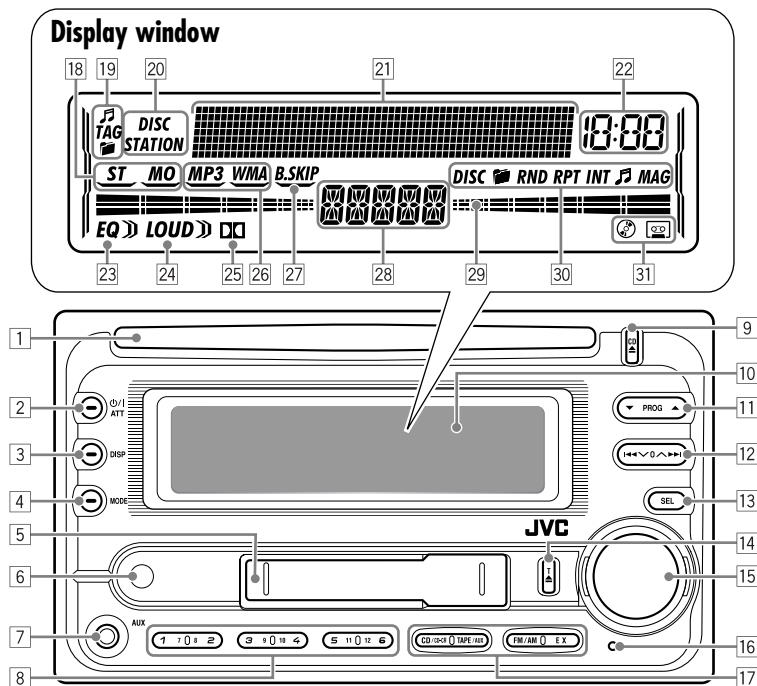

- 1 Loading slot
- 2 ATT (standby/on attenuator) button
- 3 DISP (display) button
- 4 MODE button
- 5 Cassette compartment
- 6 Remote sensor
 - *DO NOT expose the remote sensor to strong light (direct sunlight or artificial lighting).*
- 7 AUX (auxiliary) input jack
- 8 Number buttons
- 9 CD (CD eject) button
- 10 Display window
- 11 (up) / (down) buttons
PROG (program) / buttons
- 12 / buttons
- 13 SEL (select) button
- 14 T (tape eject) button
- 15 Control dial
- 16 Reset button
- 17 Source buttons—CD/CD-CH, TAPE/AUX, FM/AM, EX (extra)

Display window

- 18 Tuner reception indicators—ST (stereo), MO (monaural)
- 19 Disc information indicators— (track/file), TAG (ID3 Tag), (folder)
- 20 Text name indicators—DISC, STATION
- 21 Main display, level meter
- 22 Clock indicator
- 23 EQ (equalizer) indicator
- 24 LOUD (loudness) indicator
- 25 (Dolby B NR) indicator
- 26 Playback disc indicators—MP3, WMA
- 27 B.SKIP (blank skip) indicator
- 28 Source display
- 29 Level meter, volume meter, time countdown indicator
- 30 Playback mode indicators—DISC, (folder), RND (random), RPT (repeat), INT (intro), (track/file), MAG (magazine)
- 31 Loaded source indicators— (disc), (tape)

Remote controller — RM-RK50

Installing the lithium coin battery (CR2025)

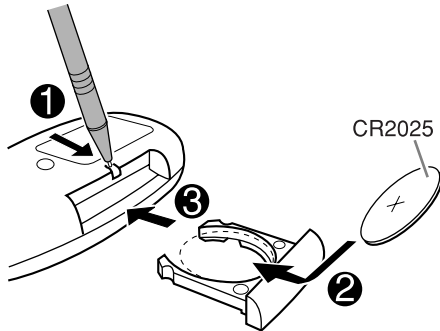

- When operating, aim the remote controller directly at the remote sensor on the unit. Make sure there is no obstacle in between.

Warning:

- Do not install any battery other than CR2025 or its equivalent; otherwise, it may explode.
- Store the battery in a place where children cannot reach to avoid risk of accident.
- To prevent the battery from over-heating, cracking, or starting a fire:
 - Do not recharge, short, disassemble, heat the battery, or dispose of it in a fire.
 - Do not leave the battery with other metallic materials.
 - Do not poke the battery with tweezers or similar tools.
 - Wrap the battery with tape and insulate when throwing away or saving it.

Caution:

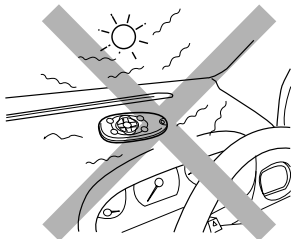

Main elements and features

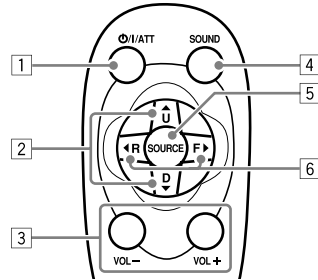

- 1 **⏻/ATT** (standby/on/attenuator) button
 - Turns the power on if pressed briefly and attenuates the sound when the power is on.
 - Turns the power off if pressed and held.
- 2 **▲ U** (up) / **▼ D** (down) buttons
 - Changes the FM/AM bands with **▲ U** only.
 - Changes the preset stations with **▼ D** only.
 - Changes the folder of the MP3/WMA discs.
 - Changes the tape directions with **▲ U** only.
 - While playing an MP3 disc on an MP3-compatible CD changer:
 - Changes the disc if pressed briefly.
 - Changes the folder if pressed and held.
- 3 **VOL -** / **VOL +** buttons
 - Adjusts the volume level.
- 4 **SOUND** button
 - Selects the sound mode (EQ: equalizer).
- 5 **SOURCE** button
 - Selects the source.
- 6 **◀ R** (reverse) / **F** (forward) **▶** buttons
 - Searches for stations if pressed briefly.
 - Fast-forwards or reverses the track if pressed and held.
 - Changes the tracks of the disc if pressed briefly.
 - Fast-forwards or reverses the tape if pressed and held.*
 - Finds the beginning of a tune (MMS) while listening to a tape if pressed briefly.*

* To release these operations, press **▲ U**. Playback resumes.

Getting started

Basic operations

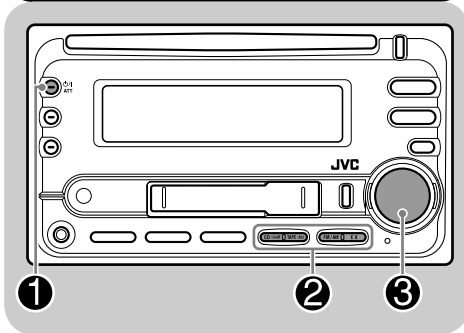

- 1** Turn on the power.



- 2** For FM/AM tuner

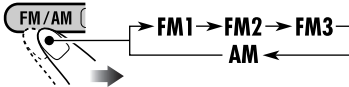

For your favorite station



- Stored your favorite station, see page 10 for details.

For CD/CD-CH



Select "CD-CH" when using an Apple iPod® or a JVC D. player (see page 22).

iPod is a trademark of Apple Computer, Inc., registered in the U.S. and other countries.

For TAPE/AUX



* You cannot select these sources if they are not ready.

- 3** Adjust the volume.

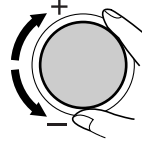

Volume level appears.

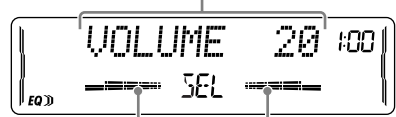

Volume level indicator

- 4** Adjust the sound as you want.
(See pages 18 and 19.)

To drop the volume in a moment (ATT)



To restore the sound, press it again.

To turn off the power



Canceling the display demonstrations

If no operations are done for about 20 seconds, display demonstration starts.

[Initial: DEMO ON]—see page 20.

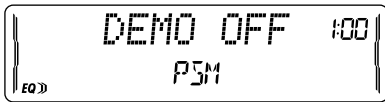
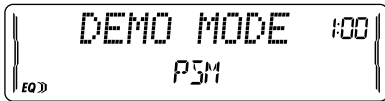
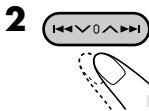

4 Finish the procedure.



To activate the display demonstration

In step 3 above...



Setting the clock



2 Set the hour and minute.

- 1 Select "CLOCK HOUR," then adjust the hour.
- 2 Select "CLOCK MIN," (minute) then adjust the minute.

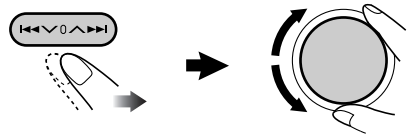

3 Finish the procedure.



Radio operations

Listening to the radio

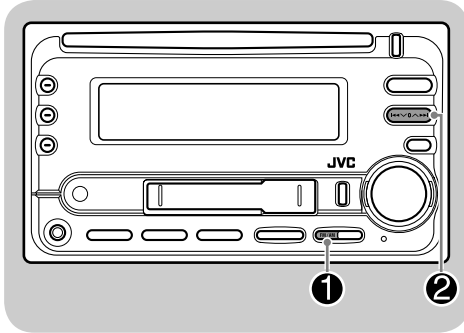

1

FM/AM → FM1 → FM2 → FM3
AM ←

Lights up when receiving an FM stereo broadcast with sufficient signal strength.

Selected band appears.

2 Start searching for a station.

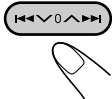

When a station is received, searching stops.
To stop searching, press the same button again.

To tune in to a station manually

In step 2 above...

1

2 Select the desired station frequencies.

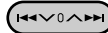

When an FM stereo broadcast is hard to receive

1

2

Lights up when monaural mode is activated.

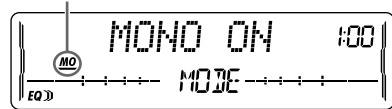

Reception improves, but stereo effect will be lost.

To restore the stereo effect, repeat the same procedure. Then, in step 2, select "MONO OFF."

Storing stations in memory

You can preset six stations for each band.

FM station automatic presetting—SSM (Strong-station Sequential Memory)

1 Select the FM band (FM1 – FM3) you want to store into.

To be continued....

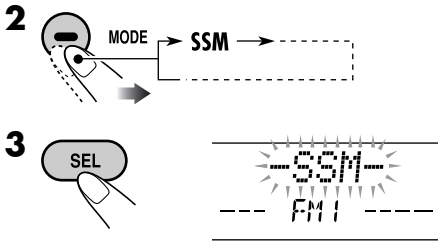

“SSM” flashes, then disappears when automatic presetting is over.

Local FM stations with the strongest signals are searched and stored automatically in the FM band.

Manual presetting

Ex.: Storing FM station of 92.5 MHz into the preset number 4 of the FM1 band.

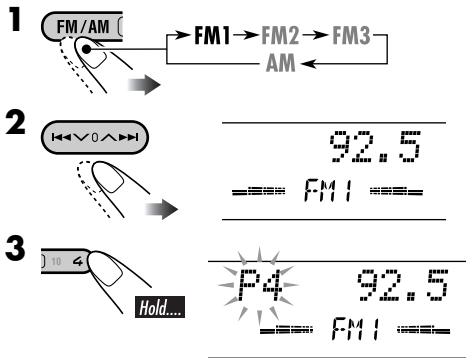

Preset number flashes for a while.

Storing your favorite station into the EX (extra) button

Ex.: Storing your favorite FM station of 92.5 MHz into the EX button

While listening to an FM station, tune in to your favorite station, then....



Listening to a preset station

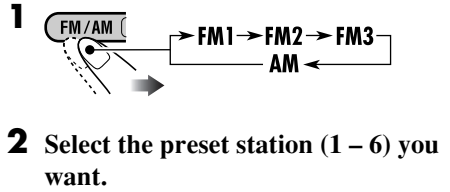

or



To tune in to your favorite station (EX)



If you press the button again, the previous source will be played back again.

Scanning broadcast stations



2 Start scanning.

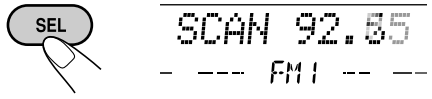

Each time a broadcast is tuned in, scanning stops for about 5 seconds (tuned frequency appears on the display), and you can check what program is now being broadcast.

3 Start listening to the program.

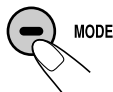

Assigning titles to the stations

You can assign titles to 30 station frequencies (including both FM and AM). Each station name can be assigned up to 10 characters. However, you cannot assign title to the station frequency stored in the EX button.

1 Tune in to the station you would like to assign a title to.

2 Enter the assigning mode.



3 Assign a title.

1 Select a character set.

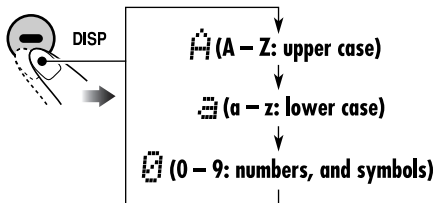

2 Select a character.

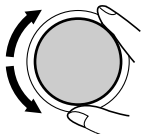

3 Move to the next (or previous) character position.

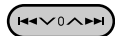

4 Repeat steps **1** to **3** until you finish entering the title.

4 Finish the procedure.



To erase the entire title

In step **3** on the left...

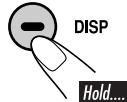

To change the information shown on the display

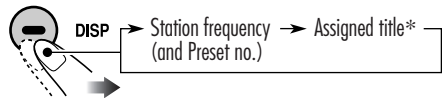

* If no title is assigned, "NO NAME" appears for a while.

Available characters

Upper case

A	B	C	D	E	F	G	H	I	J	K	L	M	N
O	P	Q	R	S	T	U	V	W	X	Y	Z	space	

Lower case

a	b	c	d	e	f	g	h	i	j	k	l	m	n
o	p	q	r	s	t	u	v	w	x	y	z	space	

Numbers and symbols

0	1	2	3	4	5	6	7	8	9	!	"	#	\$
%	&	'	()	*	+	,	-	.	/	:	;	<
=	>	?	@	_	`	space							

Disc operations

Playing a disc in the unit

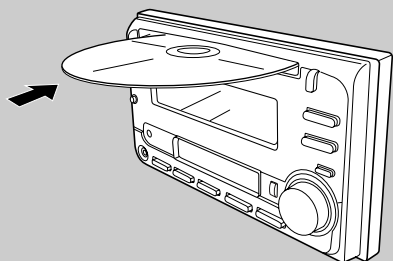

All tracks will be played repeatedly until you change the source or eject the disc.

- When inserting an MP3 or a WMA disc:

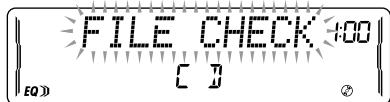

Total folder number Total file number

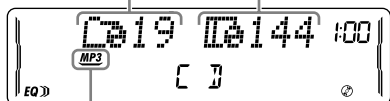

*1

Disc information appears automatically (see page 15).

Current track number*2 Elapsed playing time*2

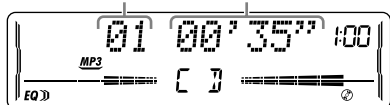

- When inserting an audio CD or a CD Text disc:

Total track number of the inserted disc Total playing time of the inserted disc

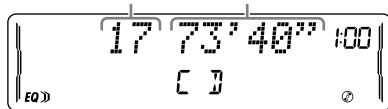

CD Text: Disc title/performer →
Track title appears automatically (see page 15).

Current track number*2 Elapsed playing time*2

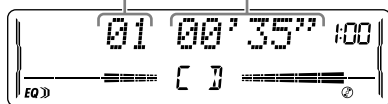

To stop play and eject the disc



The source changes to the last selected source.

*1 Either the MP3 or WMA indicator lights up depending on the detected file.

*2 Depending on the level meter setting. (See page 20 for details.)

Playing discs in the CD changer

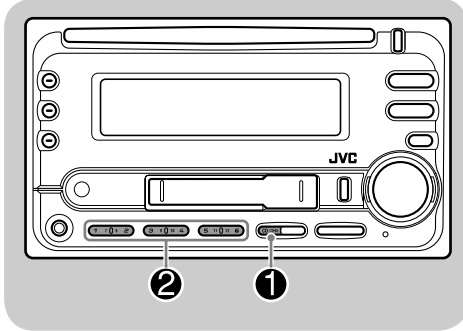

About the CD changer

It is recommended to use a JVC MP3-compatible CD changer with your unit.

- You can also connect other CH-X series CD changers (except CH-X99 and CH-X100). However, they are not compatible with MP3 discs, so you cannot play back MP3 discs.
- You cannot play any WMA disc in the CD changer.
- You cannot use the KD-MK series CD changers with this unit.
- Disc text information recorded in the CD Text can be displayed when a JVC CD Text compatible CD changer is connected.

All tracks of the inserted discs in the magazine will be played repeatedly until you change the source or eject the magazine from the CD changer.

1

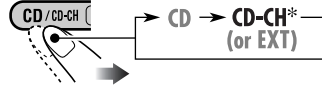

* If you have changed "EXT INPUT" setting to "EXT INPUT" (see page 21), you cannot select the CD changer.

See also page 22 for using iPod or JVC D. player.

2

Select a disc.

For disc number from 01 – 06:



For disc number from 07 – 12:

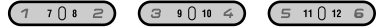

Selected disc number

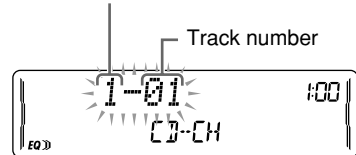

Track number



- When the current disc is an MP3 disc:

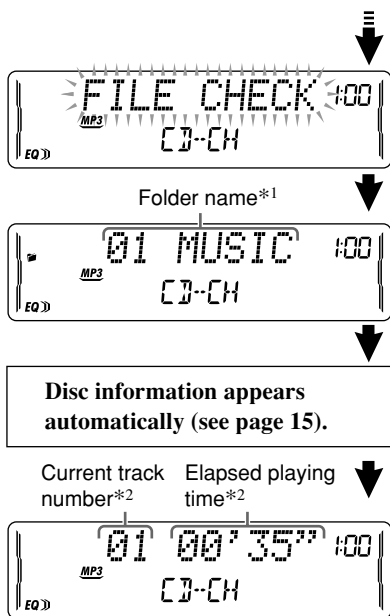

- When the current disc is an audio CD or a CD Text disc:

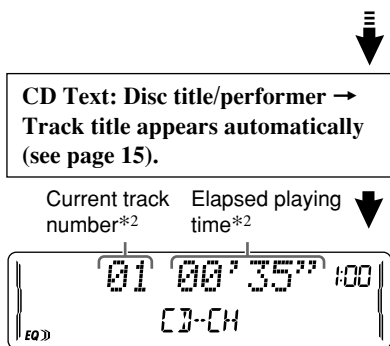

*¹ "ROOT" appears if no folder is included in the disc.

*² Depending on the level meter setting. (See page 20 for details.)

To fast-forward or reverse the track

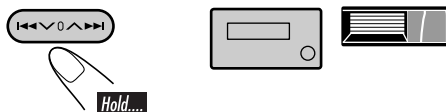

To go to the next or previous tracks

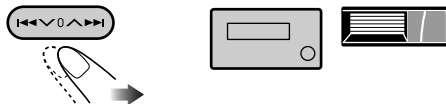

To go to the next or previous folders (for MP3 and WMA discs)

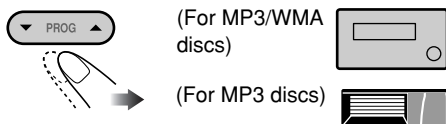

To locate a particular track (for CD) or folder (for MP3 or WMA) discs directly

To select a number from 01 – 06:

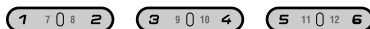

To select a number from 07 – 12:

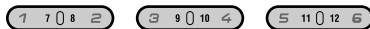

- To use folder search on MP3/WMA discs, it is required that folders are assigned with 2-digit numbers at the beginning of their folder names—01, 02, 03, and so on.

To select a particular track in a folder (for MP3 or WMA disc):

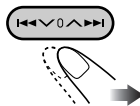

Other main functions

■ Skipping a track quickly during play



Only possible on JVC
MP3-compatible CD changer

- For MP3 or WMA disc, you can skip a track within the same folder.

Ex.: To select track 32 while playing track 6

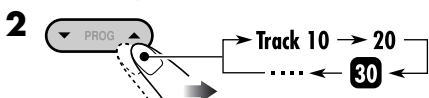
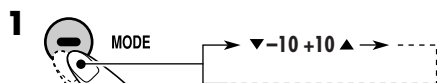

First time you press ▲ / ▼ button, the track skips to the nearest higher or lower track with a track number of multiple ten (ex. 10th, 20th, 30th).

Then each time you press the button, you can skip 10 tracks.

- After the last track, the first track will be selected and vice versa.

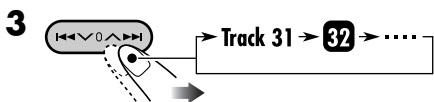

■ Prohibiting disc ejection



You can lock a disc in the loading slot.

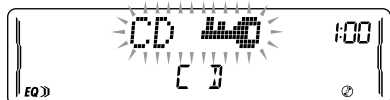

To cancel the prohibition, repeat the same procedure.

Changing the display information

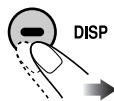

■ While playing an audio CD or a CD Text



■ While playing an MP3 or WMA disc

- When “TAG DISP” is set to “TAG ON” (see page 21)

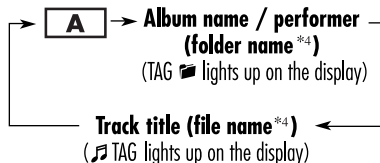

- When “TAG DISP” is set to “TAG OFF”

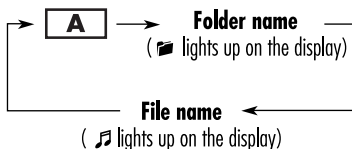

A : Current track/file number and Elapsed playing time

*3 If the current disc is an audio CD, “NO NAME” appears.

*4 If an MP3/WMA file does not have ID3 tags, folder name and file name appear. In this case, the TAG indicator will not light up.

Selecting the playback modes

You can use only one of the following playback modes at a time.

Select your desired playback mode.

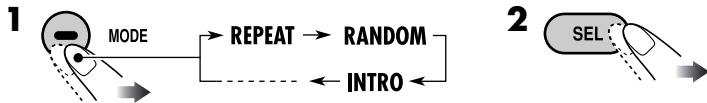

Repeat play

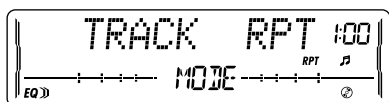

Ex.: When "TRACK RPT" is selected

Mode

Plays repeatedly

- TRACK RPT** : The current track.
 • RPT and 🎵 light up.
- FOLDER RPT*1** : All tracks of the current folder.
 • 📁 and RPT light up.
- DISC RPT*2** : All tracks of the current disc.
 • DISC and RPT light up.
- REPEAT OFF** : Cancels.

Random play

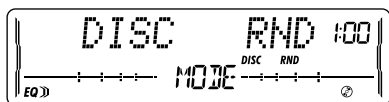

Ex.: When "DISC RND" is selected

Mode

Plays at random

- FOLDER RND*1** : All tracks of the current folder, then tracks of the next folder and so on.
 • 📁 and RND light up.
- DISC RND** : All tracks of the current disc.
 • DISC and RND light up.
- MAG RND*2** : All tracks of the inserted discs.
 • RND and MAG light up.
- RANDOM OFF** : Cancels.

Intro scan

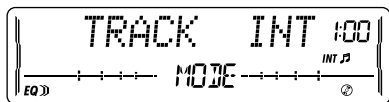

Ex.: When "TRACK INT" is selected

Mode

Plays the beginning 15 seconds of...

- TRACK INT** : All tracks of the current disc.
 • INT and 🎵 light up.
- FOLDER INT*1** : The first track of every folder of the current disc.
 • 📁 and INT light up.
- DISC INT*2** : The first tracks of the inserted discs.
 • DISC and INT light up.
- INTRO OFF** : Cancels.

*1 Only while playing an MP3 disc or WMA disc.

*2 Only while playing discs in the CD changer.

Tape operations

Playing a tape

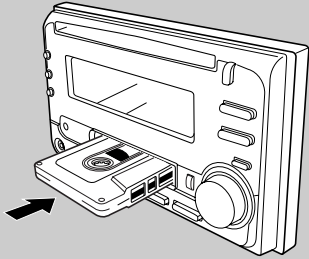

Playback starts automatically. When one side of the tape reaches its end during play, the other side of the tape automatically starts playing. (Auto Reverse)

Finding the beginning of a tune

Multi Music Scan (MMS) allows you to automatically start playback from the beginning of a specified tune.

Specify the tune you want to locate (how many tunes ahead of or before the current tune)

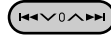

When the beginning of the specified tune is located, playback starts automatically.

MMS -9 \leftrightarrow **MMS -1***3, **MMS +1** \leftrightarrow **MMS +9**

*3 Goes back to the beginning of the current tune.

To change the playback direction



To stop play and eject the cassette



The source changes to the last selected source.

To fast-forward or rewind a tape

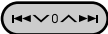

When the tape reaches its end while fast-forwarding, the tape direction will change automatically.

To stop fast-forwarding or rewinding, press the PROG button.

Prohibiting tape ejection

You can lock a tape in the loading slot.



To cancel the prohibition, repeat the same procedure.

Other convenient tape functions

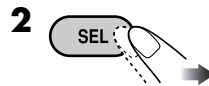
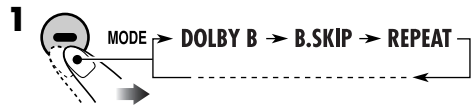

- To turn on or off Dolby B NR*4

DOLBY ON \leftrightarrow **DOLBY OFF**
(lights up on the display)

- To skip blank portions on the tape

B.SKIP ON \leftrightarrow **B.SKIP OFF**
(**B.SKIP** lights up on the display)

- To play the current tune repeatedly

REPEAT ON \leftrightarrow **REPEAT OFF**
(**RPT** lights up on the display)

*4 Manufactured under license from Dolby Laboratories. "Dolby" and the double-D symbol are trademarks of Dolby Laboratories.

Sound adjustments

Selecting preset sound modes (EQ: equalizer)

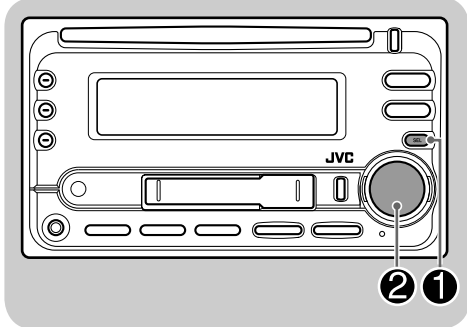

You can select a preset sound mode suitable to the music genre.

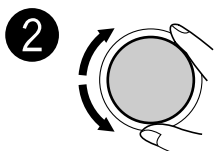
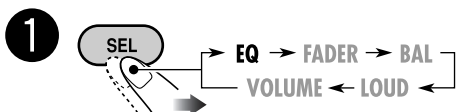

FLAT ⇄ Hard Rock ⇄ R & B ⇄
 POP ⇄ JAZZ ⇄ DanceMusic ⇄
 Country ⇄ Reggae ⇄ Classic ⇄
 USER 1 ⇄ USER 2 ⇄ USER 3 ⇄
 (back to the beginning)

To select the sound mode directly

You can select the sound mode directly using the remote controller.

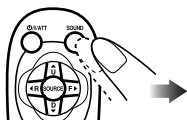

Adjusting the sound

You can adjust the sound characteristics to your preference.

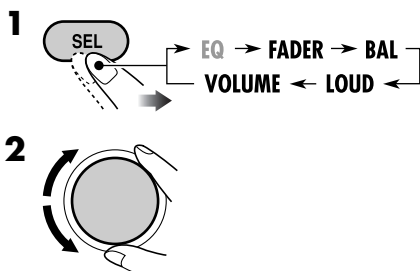

Indication	Range
FADER *1 Adjust the front and rear speaker balance.	R06 (Rear only) to F06 (Front only)
BAL (balance) Adjust the left and right speaker balance.	L06 (Left only) to R06 (Right only)
LOUD (loudness) Boost low and high frequencies to produce a well-balanced sound at low volume level.	LOUD ON ↓ LOUD OFF
VOLUME *2 Adjust the volume.	00 (min.) to 30 or 50 (max.)*3

*1 If you are using a two-speaker system, set the fader level to "00."

*2 Normally the control dial works as the volume control. So you do not have to select "VOLUME" to adjust the volume level.

*3 Depending on the amplifier gain control setting. (See page 21 for details.)

Storing your own sound adjustments

You can adjust the sound modes and store your own adjustments in memory.

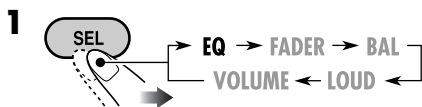

2 Select one of the sound mode to adjust.

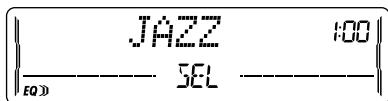
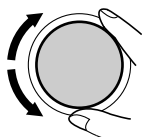

Ex.: When "JAZZ" is selected

3 Select the sound elements to adjust while the selected sound mode is shown.



LOW LEVEL ⇄ LOW FREQ. ⇄
 LOW WIDTH ⇄ MID LEVEL ⇄
 MID WIDTH ⇄ HIGH LEVEL ⇄
 HIGH FREQ. ⇄ (back to the beginning)

- **(LOW, MID, HIGH) LEVEL:**
Adjust the enhancement level.
- **(LOW, HIGH) FREQ:**
Select the center frequency to adjust.
- **(LOW, MID) WIDTH :**
Select the band width level.

4 Adjust the selected sound elements while the indication on step 3 is shown.



Indication	Preset values		
	LOW	MID	HIGH
LEVEL	-06 (min.) to +06 (max.)	-06 (min.) to +06 (max.)	-06 (min.) to +06 (max.)
FREQ	60Hz 80Hz 100Hz 120Hz	—	8kHz 10kHz 12kHz 15kHz
WIDTH	1 (min.) to 4 (max.)	1 (min.) to 2 (max.)	—

5 Repeat steps 3 and 4 to set (or adjust) the other sound elements.

6 Select one of the user sound modes (USER 1, USER 2, USER 3).

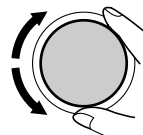
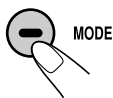

7 Store the adjustments.

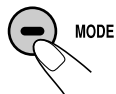

"MEMORY" appears for a while.

General settings — PSM

Basic procedure

You can change PSM (Preferred Setting Mode) items listed in the table that follows.



2 Select a PSM item.

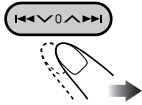

3 Adjust the PSM item selected.

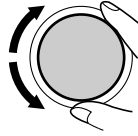

4 Repeat steps 2 and 3 to adjust the other PSM items if necessary.

5 Finish the procedure.



Indications	Selectable settings, [reference page]
DEMO MODE Display demonstration	DEMO ON : [Initial]; Display demonstration will be activated automatically if no operation is done for about 20 seconds, [8]. DEMO OFF : Cancels.
CLOCK HOUR Hour adjustment	1 – 12, [8] [Initial: 1 (1:00)]
CLOCK MIN Minute adjustment	00 – 59, [8] [Initial: 00 (1:00)]
CLOCK DISP Clock display	CLOCK ON : Clock time is shown on the display at all times even when the unit is turned off. CLOCK OFF : [Initial]; Clock time is shown when the unit is turned on. If the unit is turned off, pressing DISP will show the clock time for about 5 seconds.

LEVELMETER
Audio level meter

You can select one of the four different level meter patterns or a demonstration of all the patterns.

LEVEL ALL [Initial] ⇄ **LEVEL 1** ⇄ **LEVEL 2** ⇄ **LEVEL 3** ⇄ **LEVEL 4** ⇄ **LEVEL OFF** (canceled) ⇄ (back to the beginning)

LEVEL ALL : Demonstrates all the level meter patterns, each for about 20 seconds.

LEVEL 1

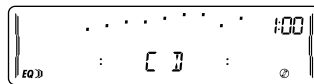

LEVEL 2

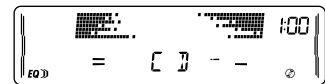

LEVEL 3

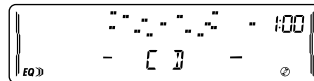

LEVEL 4

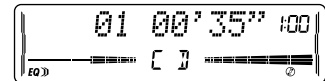

Indications	Selectable settings, [reference page]
DIMMER Dimmer	AUTO : [Initial]; Dims the display when you turn on the headlights. ON : Activates dimmer. OFF : Cancels.
CONTRAST Display contrast	1 – 10 : Adjust the display contrast to make the display indications clear and legible. [Initial: 5]
SCROLL*1 Scroll	ONCE : [Initial]; Scrolls the disc information once. AUTO : Repeats scrolling (5-second intervals in between). OFF : Cancels. • Pressing DISP for more than one second can scroll the display regardless of the setting.
EXT INPUT*2 External input	CHANGER : [Initial]; To use a JVC CD changer, an Apple iPod, or a JVC D. player, [13, 22]. EXT INPUT : To use another external component, [22].
AUX ADJUST Auxiliary input level adjustment	AUX ADJ 00 – AUX ADJ 05: Adjust the auxiliary input level accordingly, to avoid the sudden increase of the output level when changing the source from external component connected to the AUX input jack on the control panel. [Initial: AUX ADJ 00]
TAG DISP Tag display	TAG ON : [Initial]; Shows the ID3 tag while playing MP3/WMA tracks, [15]. TAG OFF : Cancels.
AMP GAIN Amplifier gain control	You can change the maximum volume level of this unit. LOW PWR : VOLUME 00 – VOLUME 30 (Select this if the maximum power of the speaker is less than 50 W to avoid damaging the speaker.) HIGH PWR : [Initial]; VOLUME 00 – VOLUME 50
IF FILTER IF filter	AUTO : [Initial]; Increases the tuner selectivity to reduce noise interference between the stations. (Stereo effect will also be lost.) WIDE : Subject to noise interference from adjacent stations, but sound quality will not be degraded and will retain the stereo effect.

*1 Some characters or symbols will not be shown (and will be blanked) or substituted on the display.

*2 Cannot be selected if the source is "CD-CH" or "EXT."

External component operations

This unit is ready for any Apple iPod® or JVC D. player control interface.

- For details, refer also to the manual supplied with the interface adapter for iPod®—KS-PD100 or D. player—KS-PD500.

Playing an external component

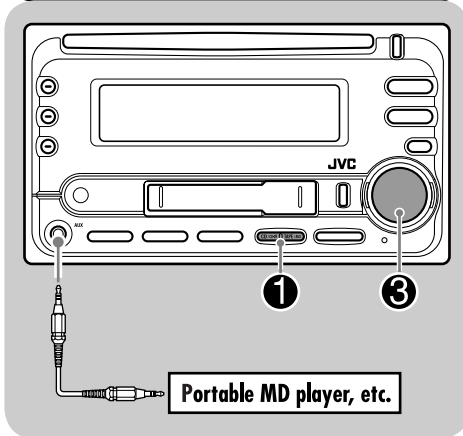

You can connect an external component to....

- CD changer jack on the rear using:
 - Line Input Adapter—KS-U57 or KS-U58 (not supplied) for any other components (except iPod or D. player).
 - Interface adapter for iPod®—KS-PD100 (not supplied) for controlling iPod.
 - D. player interface adapter—KS-PD500 (not supplied) for controlling D. player.
- AUX (auxiliary) input jack on the control panel.

For connection, see Installation/Connection Manual (separate volume).

- 1 For selecting the external component connected to....
 - AUX input jack

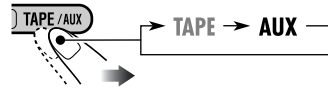

- CD changer jack on the rear using KS-U57 or KS-U58
If "EXT" does not appear, see page 21 and select the external input (EXT INPUT).

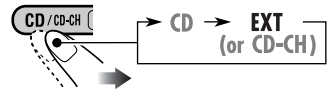

- CD changer jack on the rear using interface adapter for iPod —KS-PD100 or for D. player—KS-PD500

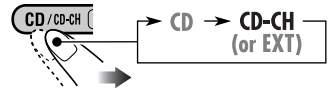

- 2 Turn on the connected component and start playing the source.

- 3 Adjust the volume.

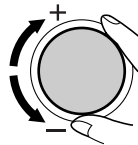

- 4 Adjust the sound as you want. (See pages 18 and 19.)

Maintenance

Handling discs

Moisture condensation

Moisture may condense on the lens inside the CD player in the following cases:

- After starting the heater in the car.
- If it becomes very humid inside the car.

Should this occur, the CD player may malfunction. In this case, eject the disc and leave the unit turned on for a few hours until the moisture evaporates.

How to handle discs

When removing a disc from its case, press down the center holder of the case and lift the disc out, holding it by the edges.

Center holder



- Always hold the disc by the edges. Do not touch its recording surface.

When storing a disc into its case, gently insert the disc around the center holder (with the printed surface facing up).

- Make sure to store discs into the cases after use.

To keep discs clean

A dirty disc may not play correctly. If a disc does become dirty, wipe it with a soft cloth in a straight line from center to edge.



- Do not use any solvent (for example, conventional record cleaner, spray, thinner, benzene, etc.) to clean discs.

To play new discs

New discs may have some rough spots around the inner and outer edges. If such a disc is used, this unit may reject the disc.



To remove these rough spots, rub the edges with a pencil or ball-point pen, etc.

Do not use the following discs:

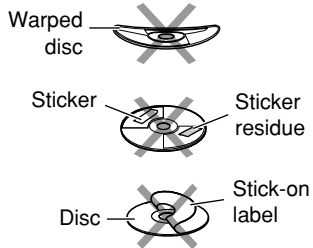

Handling cassettes

To clean the head

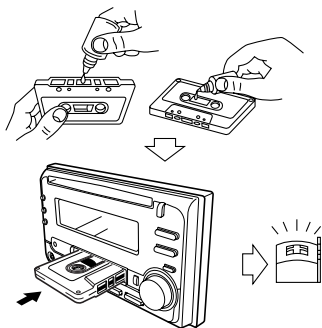

- Clean the heads after every 10 hours of use using a wet-type head cleaning tape (available at an audio store).
When the head becomes dirty, you may realize the following symptoms:
 - Sound quality is reduced.
 - Sound level decreases.
 - Sound drops out.
- Do not touch the highly-polished head with any metallic or magnetic tools.

To keep the tape clean

- Always store the cassettes in their storage cases after use.
- Do not store cassettes in the following places:
 - Subject to direct sunlight
 - With high humidity
 - At extremely hot temperatures

More about this unit

Basic operations

Turning on the power

- By pressing the source buttons on the unit, you can also turn on the power. If the source is ready, playback also starts.

Turning off the power

- If you turn off the ignition key without turning off this unit, the unit will automatically turn on when you turn on the ignition key next time. If the last selected source is ready for playback (ex. a disc or a tape is in the unit), playback starts automatically.
- If you turn off the power while listening to a disc, disc play will start from where playback has been stopped previously, next time you turn on the power.

Selecting the sources

- When no disc or cassette is loaded in the unit, “CD” or “TAPE” cannot be selected.
- Without connecting to the CD changer, “CD-CH” cannot be selected.

Tuner operations

Storing stations in memory

- During SSM search...
 - All previously stored stations are erased and stations are stored newly.
 - Received stations are preset in No. 1 (lowest frequency) to No. 6 (highest frequency).
 - When SSM is over, the station stored in No. 1 will be automatically tuned in.
- When storing a station manually, a previously preset station is erased when a new station is stored in the same preset number.

Disc operations

Caution for DualDisc playback

- The Non-DVD side of a “DualDisc” does not comply with the “Compact Disc Digital Audio” standard. Therefore, the use of Non-DVD side of a DualDisc on this product may not be recommended.

General

- MP3 and WMA (Windows Media® Audio) “tracks” (words “file” and “track” are used interchangeably) are recorded in “folders.”
- This unit has been designed to reproduce CDs/CD Texts, and CD-Rs (Recordable)/CD-RWs (Rewritable) in audio CD (CD-DA), MP3 and WMA format.
- When a disc has been loaded, selecting “CD” for the playback source starts disc play.

Inserting a disc

- When a disc is inserted upside down, the disc automatically ejects and the unit starts playing the last selected source.
- Do not insert 8 cm discs (single CD) and unusual shape discs (heart, flower, etc.) into the loading slot.

Playing a disc

- While fast-forwarding or reversing on an MP3 or WMA disc, you can only hear intermittent sounds.

Playing a CD-R or CD-RW

- Use only “finalized” CD-Rs or CD-RWs.
- This unit can play back only the files of the same type which is first detected if a disc includes both audio CD (CD-DA) files and MP3/WMA files.
- This unit can play back multi-session discs; however, unclosed sessions will be skipped while playing.

- Some CD-Rs or CD-RWs may not play back on this unit because of their disc characteristics, and for the following causes:
 - Discs are dirty or scratched.
 - Moisture condensation occurs on the lens inside the unit.
 - The pickup lens inside the unit is dirty.
 - CD-R/CD-RW on which the files are written with “Packet Write” method.
 - There are improper recording conditions (missing data, etc.) or media conditions (stain, scratch, warp, etc.).
- CD-RWs may require a longer readout time since the reflectance of CD-RWs is lower than that of regular CDs.
- Do not use the following CD-Rs or CD-RWs:
 - Discs with stickers, labels, or protective seal stuck to the surface.
 - Discs on which labels can be directly printed by an ink jet printer.
 Using these discs under high temperatures or high humidity may cause malfunctions or damages to the unit.
- The maximum number of characters for file/folder names vary among the disc format used (includes 4 extension characters—<.mp3> or <.wma>).
 - ISO 9660 Level 1: up to 12 characters
 - ISO 9660 Level 2: up to 31 characters
 - Romeo*: up to 128 (72) characters
 - Joliet*: up to 64 (36) characters
 - Windows long file name*: up to 128 (72) characters
 * *The parenthetic figure is the maximum number of characters for file/folder names in case the total number of files and folders is 313 or more.*
- This unit can recognize the total of 512 files, of 200 folders, and of 8 hierarchies.
- This unit can play back the files recorded in VBR (variable bit rate).
The files recorded in VBR have a discrepancy in elapsed time display, and do not show the actual elapsed time. This difference becomes noticeable especially after performing the search function.

Playing an MP3/WMA disc

- This unit can play back MP3/WMA files with the extension code <.mp3> or <.wma> (regardless of the letter case—upper/lower).
- This unit can show the names of albums, artists (performer), and ID3 Tag (Version 1.0, 1.1, 2.2, 2.3, or 2.4) for MP3 files and for WMA files.
- This unit can display only one-byte characters. No other characters can be correctly displayed (see page 11).
- This unit can play back MP3/WMA files meeting the conditions below:
 - Bit rate: 8 kbps — 320 kbps
 - Sampling frequency:
 - 48 kHz, 44.1 kHz, 32 kHz (for MPEG-1)
 - 24 kHz, 22.05 kHz, 16 kHz (for MPEG-2)
 - 48 kHz, 44.1 kHz, 32 kHz (for WMA)
 - Disc format: ISO 9660 Level 1/ Level 2, Romeo, Joliet, Windows long file name
- This unit cannot play back the following files:
 - MP3 files encoded with MP3i and MP3 PRO format.
 - MP3 files encoded in an unappropriated format.
 - MP3 files encoded with Layer 1/2.
 - WMA files encoded with lossless, professional, and voice format.
 - WMA files which are not based upon Windows Media® Audio.
 - WMA files copy-protected with DRM.
 - Files which have the data such as WAVE, ATRAC3, etc.
- The search function works but search speed is not constant.

To be continued....

Changing the source

- If you change the source, playback also stops (without ejecting the disc). Next time you select “CD” or “CD-CH” for the playback source, disc play starts from where it has been stopped previously.

Ejecting a disc

- If the ejected disc is not removed within 15 seconds, the disc is automatically inserted again into the loading slot to protect it from dust. (Disc will not play this time.)

Tape operations

Playing a tape

- While locating a specified tune:
 - If the tape is rewound to its beginning, playback starts from the beginning of that side.
 - If the tape is fast-forwarded to the end, it is reversed and played from the beginning of the other side.
- In the following cases, Multi Music Scan (MMS), Blank Skip, and Repeat Play may not operate correctly:
 - Tapes with tunes having long pianissimo passages (very quiet parts) or non-recorded portions.
 - Tapes with short non-recorded sections.
 - Tapes with high level noise or humming between tunes.
 - The Dolby NR setting does not match. For example, if the tape is recorded with the Dolby C NR.
- Do not use the following tape:
 - Dirty or dusty tapes.
 - Cassette with peeling labels.
 - Loose tape which may become entangled with the mechanism.

Changing the source

- If you change the source, playback also stops (without ejecting the cassette).

Ignition key-off release

- When you turn off the ignition key with a cassette in the compartment, the unit automatically releases the tape from its head.

General settings—PSM

- If you change the “TAG DISP” setting from “TAG OFF” to “TAG ON” while playing MP3/WMA file, the tag display will be activated when the next file starts playing.
- If you change the “AMP GAIN” setting from “HIGH PWR” to “LOW PWR” while the volume level is set higher than “VOLUME 30,” the unit automatically changes the volume level to “VOLUME 30.”

Other main functions

- If you try to assign a title to the 31st station frequency, “NAME FULL” flashes. Delete unwanted titles before assignment.

Troubleshooting

What appears to be trouble is not always serious. Check the following points before calling a service center.

	Symptoms	Remedies/Causes
General	<ul style="list-style-type: none"> • Sound cannot be heard from the speakers. 	<ul style="list-style-type: none"> • Adjust the volume to the optimum level. • Check the cords and connections.
	<ul style="list-style-type: none"> • The unit does not work at all. 	Reset the unit (see page 2).
FM/AM	<ul style="list-style-type: none"> • SSM automatic presetting does not work. 	Store stations manually.
	<ul style="list-style-type: none"> • Static noise while listening to the radio. 	Connect the antenna firmly.
Disc playback	<ul style="list-style-type: none"> • Disc cannot be played back. 	Insert the disc correctly.
	<ul style="list-style-type: none"> • CD-R/CD-RW cannot be played back. • Tracks on the CD-R/CD-RW cannot be skipped. 	<ul style="list-style-type: none"> • Insert a finalized CD-R/CD-RW. • Finalize the CD-R/CD-RW with the component which you used for recording.
	<ul style="list-style-type: none"> • Disc can be neither played back nor ejected. 	<ul style="list-style-type: none"> • Unlock the disc (see page 15). • Eject the disc forcibly (see page 2).
	<ul style="list-style-type: none"> • Disc sound is sometimes interrupted. 	<ul style="list-style-type: none"> • Stop playback while driving on rough roads. • Use an unscratched disc. • Check the cords and connections.
	<ul style="list-style-type: none"> • “NO DISC” appears on the display. 	Insert a correct disc into the loading slot.
MP3/WMA playback	<ul style="list-style-type: none"> • Disc cannot be played back. 	<ul style="list-style-type: none"> • Use a disc with MP3/WMA tracks recorded in the format compliant with ISO 9660 Level 1, Level 2, Romeo, or Joliet. • Add the extension code <.mp3> or <.wma> to the file names.
	<ul style="list-style-type: none"> • Noise is generated. 	Skip to another track or change the disc. (Do not add the extension code <.mp3> or <.wma> to non-MP3 or WMA tracks.)
	<ul style="list-style-type: none"> • A longer readout time is required (“CHECK” keeps flashing on the display). 	Do not use too many hierarchies and folders.

To be continued....

	Symptoms	Remedies/Causes
MP3/WMA playback	• Tracks do not play back in the order you have intended them to play.	Playback order is determined when the files are recorded.
	• Elapsed playing time is not correct.	This sometimes occurs during play. This is caused by how the tracks are recorded on the disc.
	• “NO FILES” appears on the display.	Insert a disc that contains MP3/WMA tracks.
	• Correct characters are not displayed (e.g. album name).	This unit can only display alphabets (upper/lower case), numbers, and a limited number of symbols.
Tape playback	• A cassette cannot be inserted.	Insert the cassette with the exposed tape facing right.
	• Cassette can be neither played back nor ejected.	Unlock the cassette (see page 17).
	• “NO TAPE” appears on the display.	Insert a cassette correctly.
	• Cassette tapes become hot.	This is not a malfunction.
	• Tape sound is at very low level and sound quality is degraded.	Clean the tape head using a head cleaning tape.
CD changer	• “NO DISC” appears on the display.	Insert a disc into the magazine.
	• “NO MAG” appears on the display.	Insert the magazine.
	• “RESET 8” appears on the display.	Connect this unit and the CD changer correctly and press the reset button of the CD changer.
	• “RESET 1” – “RESET 7” appears on the display.	Press the reset button of the CD changer.
	• The CD changer does not work at all.	Reset the unit (see page 2).

- Microsoft and Windows Media are either registered trademarks or trademarks of Microsoft Corporation in the United States and/or other countries.

Specifications

AUDIO AMPLIFIER SECTION

Maximum Power Output:

Front: 50 W per channel

Rear: 50 W per channel

Continuous Power Output (RMS):

Front: 19 W per channel into 4 Ω , 40 Hz to 20 000 Hz at no more than 0.8% total harmonic distortion.

Rear: 19 W per channel into 4 Ω , 40 Hz to 20 000 Hz at no more than 0.8% total harmonic distortion.

Load Impedance: 4 Ω (4 Ω to 8 Ω allowance)

Equalizer Control Range:

Low: ± 12 dB (60 Hz, 80 Hz, 100 Hz, 120 Hz)

Mid: ± 12 dB

High: ± 12 dB (8 kHz, 10 kHz, 12 kHz, 15 kHz)

Frequency Response: 40 Hz to 20 000 Hz

Signal-to-Noise Ratio: 70 dB

Line-Out Level/Impedance:

2.0 V/20 k Ω load (full scale)

Output Impedance: 1 k Ω

Other terminals: CD changer, AUX (auxiliary) input jack

TUNER SECTION

Frequency Range:

FM: 87.5 MHz to 108.0 MHz

AM: 531 kHz to 1 602 kHz

[FM Tuner]

Usable Sensitivity: 11.3 dBf (1.0 μ V/75 Ω)

50 dB Quieting Sensitivity:

16.3 dBf (1.8 μ V/75 Ω)

Alternate Channel Selectivity (400 kHz): 65 dB

Frequency Response: 40 Hz to 15 000 Hz

Stereo Separation: 30 dB

Capture Ratio: 1.5 dB

[AM Tuner]

Sensitivity: 20 μ V

Selectivity: 35 dB

CD PLAYER SECTION

Type: Compact disc player

Signal Detection System: Non-contact optical pickup (semiconductor laser)

Number of Channels: 2 channels (stereo)

Frequency Response: 5 Hz to 20 000 Hz

Dynamic Range: 96 dB

Signal-to-Noise Ratio: 98 dB

Wow and Flutter: Less than measurable limit

MP3 Decoding Format:

MPEG1/2 Audio Layer 3

Max. Bit Rate: 320 kbps

WMA (Windows Media[®] Audio) Decoding Format:

Max. Bit Rate: 192 kbps

CASSETTE DECK SECTION

Wow and Flutter: 0.1 % (WRMS)

Fast-Wind Time: 100 sec. (C-60)

Frequency Response: 30 Hz to 16 000 Hz (Normal tape)

Signal-to-Noise Ratio: (Normal tape)

Dolby B NR ON: 65 dB

Dolby B NR OFF: 56 dB

Stereo Separation: 40 dB

GENERAL

Power Requirement:

Operating Voltage:

DC 14.4 V (11 V to 16 V allowance)

Grounding System: Negative ground

Allowable Operating Temperature:

0°C to +40°C

Dimensions (W \times H \times D):

Installation Size (approx.):

178 mm \times 100 mm \times 158 mm

Set Size (approx.):

178 mm \times 100 mm \times 175 mm

Mass (approx.):

2.3 kg (excluding accessories)

Design and specifications are subject to change without notice.



Having TROUBLE with operation?

Please reset your unit

Refer to page of How to reset your unit

JVC



JVC KW-XC404

Installation/Connection Manual

GET0328-002A
[UI]

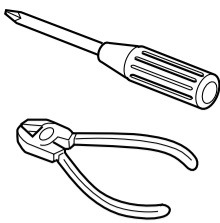

0805DTSMDTJEIN
EN

© 2005 Victor Company of Japan, Limited

- This unit is designed to operate on 12 V DC, **NEGATIVE ground electrical systems**. If your vehicle does not have this system, a voltage inverter is required, which can be purchased at JVC car audio dealers.

Parts list for installation and connection

The following parts are provided for this unit.
After checking them, please set them correctly.



Flat countersunk screws
(M5 x 8 mm)



Binding screws
(M5 x 8 mm)



CR2025
Battery



RM-RK50
Remote controller

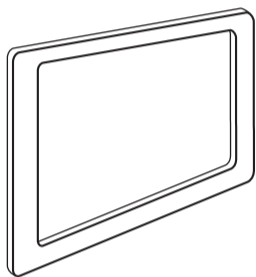
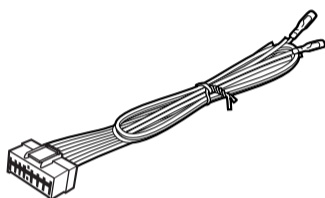
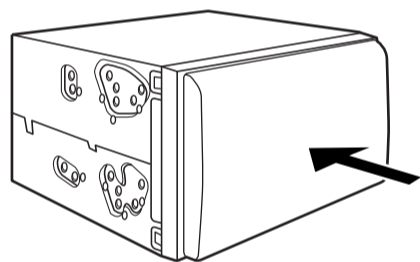

Plate for use with a Nissan car



Power cord

When installing the unit in a Nissan car



Fix the supplied plate as illustrated.

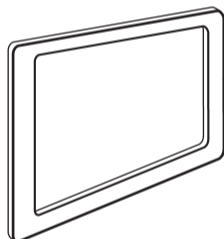
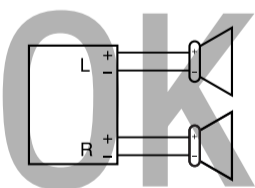
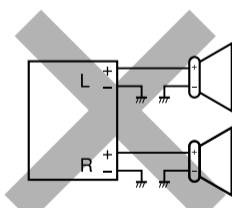
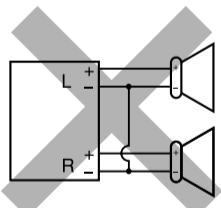

Plate for use with a
Nissan car

PRECAUTIONS on power supply and speaker connections:

- DO NOT** connect the speaker leads of the power cord to the car battery; otherwise, the receiver will be seriously damaged.
- BEFORE connecting the speaker leads of the power cord to the speakers, check the speaker wiring in your car.



TROUBLESHOOTING

- The fuse blows.**
 - Are the red and black leads connected correctly?
- Power cannot be turned on.**
 - Is the yellow lead connected?
- No sound from the speakers.**
 - Is the speaker output lead short-circuited?
- Sound is distorted.**
 - Is the speaker output lead grounded?
 - Are the "-" terminals of L and R speakers grounded in common?
- Noise interfere with sounds.**
 - Is the rear ground terminal connected to the car's chassis using shorter and thicker cords?
- Unit becomes hot.**
 - Is the speaker output lead grounded?
 - Are the "-" terminals of L and R speakers grounded in common?
- This unit does not work at all.**
 - Have you reset your unit?

INSTALLATION (IN-DASH MOUNTING)

The following illustration shows a typical installation. However, you should make adjustments corresponding to your specific car. In this case consult the manual included with the installation kit (option).

In some case, depending of the type and the model of your car, it is not possible to install the unit into the center console.

If you have any questions or require information regarding installation kits, consult your JVC car audio dealer or a company supplying kits.

- If you are not sure how to install this unit correctly, have it installed by a qualified technician.

Before installing the unit

- When mounting the unit, be sure to use the screws provided, as instructed. If other screws are used, there is a possibility that parts could become loose or damaged.
- When tightening screws or bolts be careful not to pinch any connection cord.

- Remove the audio system originally installed together with the mounting brackets.
Note: Be sure to keep all the screws and parts removed from your car for future use.
- Attach the mounting brackets (removed from the car), to this unit (see below).
- Connect the wires (see diagram ).
- Fix this unit to the car using the screws removed in step 1.
 - See "Caution" below.

The following example shown is for installation in a Toyota. For more details, consult your JVC car audio dealer.

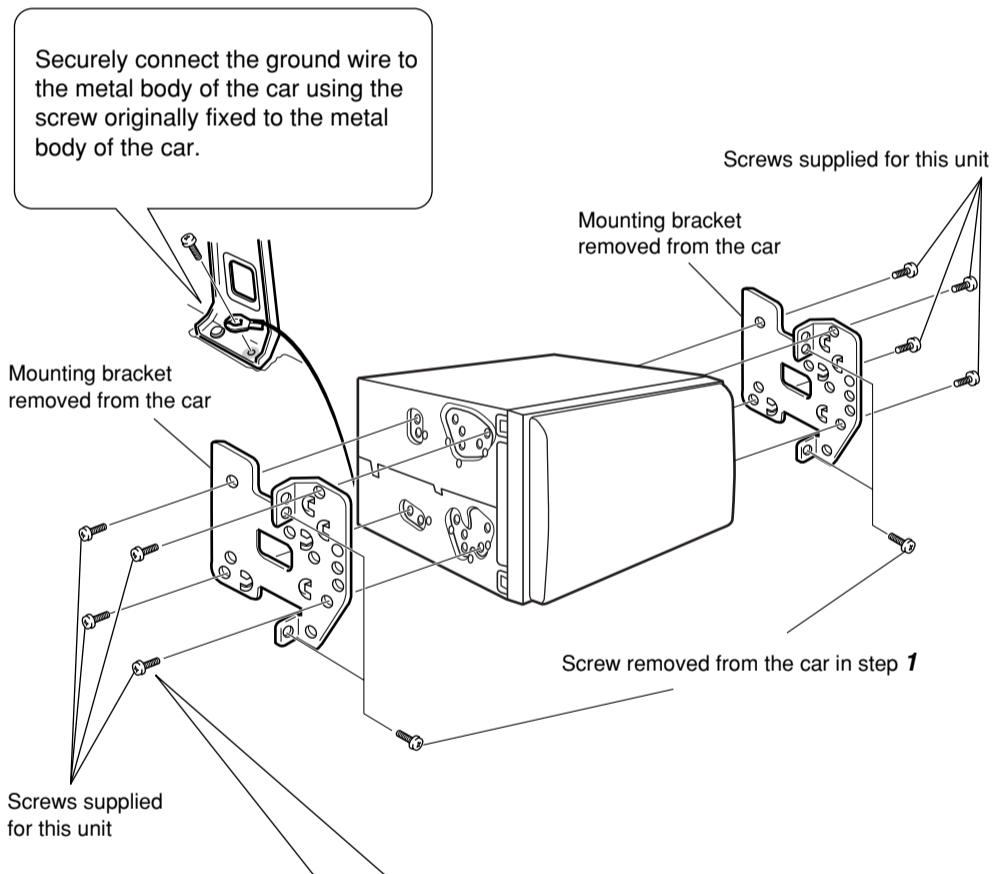

Screws supplied for this unit:

Select the proper screw type, fitting to your car.

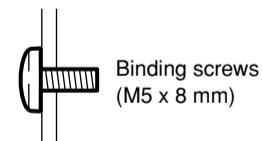

Binding screws
(M5 x 8 mm)



Flat countersunk
screws (M5 x 8 mm)

Caution:

To install the mounting brackets to the unit, use only the supplied screws (M5 x 8 mm). If you use any screw longer than 8 mm, the unit can be damaged.

If there is an interfering tab on the mounting bracket, bent it flat.

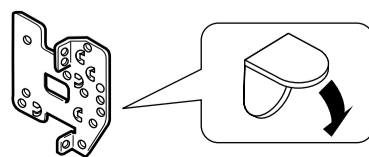

Install the unit at an angle of less than 30°.

Less than 30°

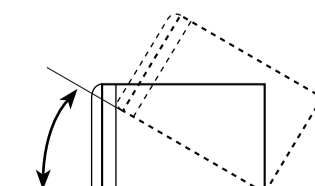

ELECTRICAL CONNECTIONS

To prevent short circuits, we recommend that you disconnect the battery's negative terminal and make all electrical connections before installing the unit.

- **Be sure to ground this unit to the car's chassis again after installation.**

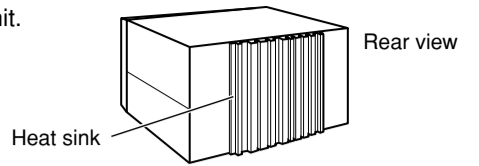

Notes:

- Replace the fuse with one of the specified rating. If the fuse blows frequently, consult your JVC car audio dealer.
- If noise is a problem...

This unit incorporates a noise filter in the power circuit. However, with some vehicles, clicking or other unwanted noise may occur. If this happens, connect the unit's **rear ground terminal** to the car's chassis using shorter and thicker cords, such as copper braiding or gauge wire. If noise still persists, consult your JVC car audio dealer.

- It is recommended to connect to the speakers with maximum power of more than 50 W (both at the rear and at the front, with an impedance of **4 Ω to 8 Ω**). If the maximum power is less than 50 W, change "AMP GAIN" setting to prevent the speakers from being damaged (see page 21 of the INSTRUCTIONS).
- The heat sink becomes very hot after use. Be careful not to touch it when removing this unit.

A Typical Connections

Before connecting: Check the wiring in the vehicle carefully. Incorrect connection may cause serious damage to this unit.

- 1 Connect the colored leads of the power cord in the order specified in the illustration below.
- 2 Connect the antenna cord.
- 3 Finally connect the wiring harness to the unit.

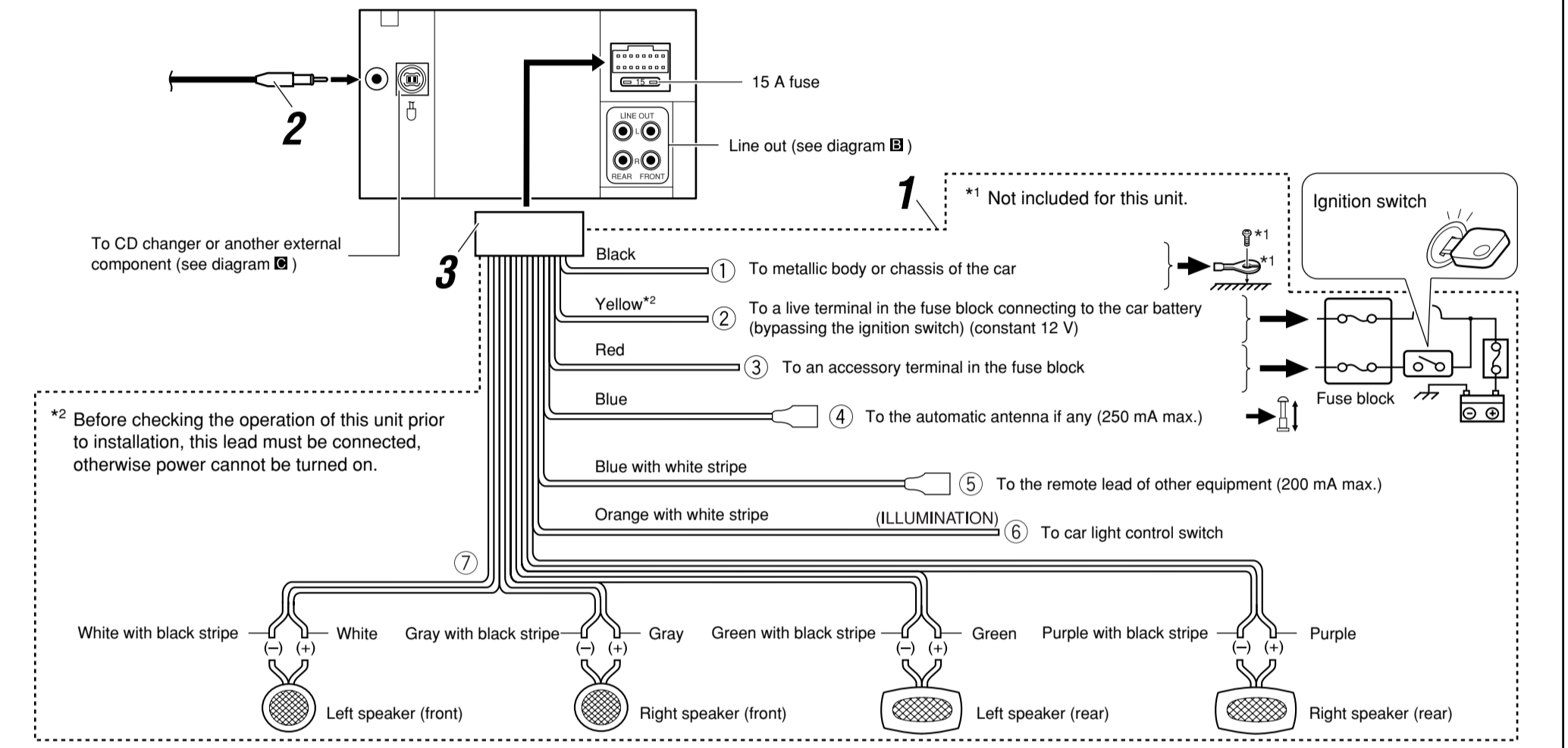

B Connecting the external amplifiers

You can connect an amplifier to upgrade your car stereo system.

- Connect the remote lead (blue with white stripe) to the remote lead of the other equipment so that it can be controlled through this unit.
- **Disconnect the speakers from this unit, connect them to the amplifier. Leave the speaker leads of this unit unused.**

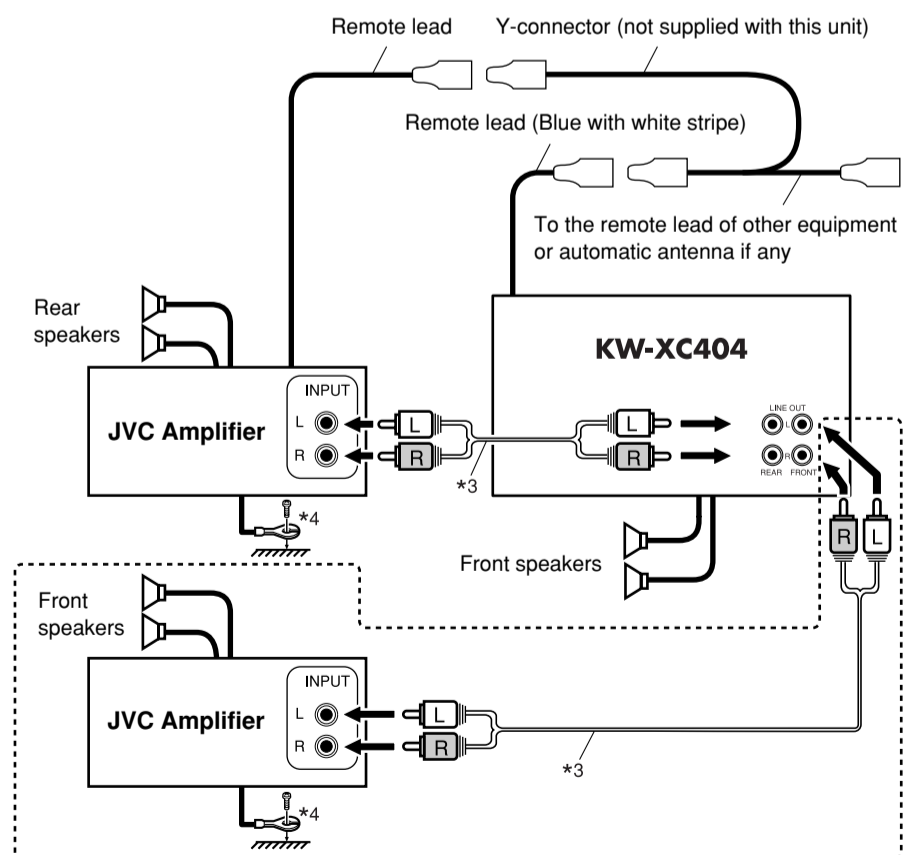

C Connecting the external components

- Set "EXT INPUT" to "CHANGER" (see page 21 of the INSTRUCTIONS).

CD Changer

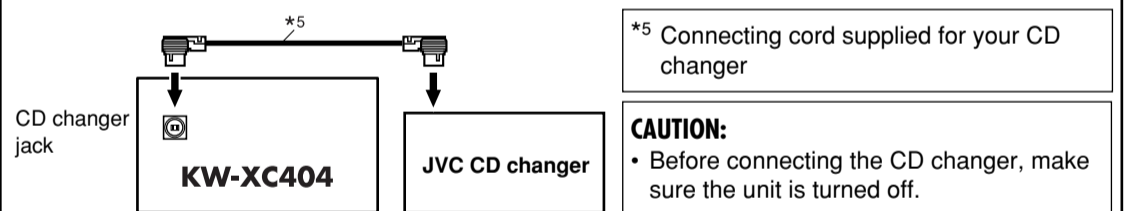

Apple iPod® or JVC D. player

You can connect an iPod or a D. player using an interface adapter (not supplied)—KS-PD100 (for iPod) or KS-PD500 (for D. player).

iPod is a trademark of Apple Computer, Inc., registered in the U.S. and other countries.

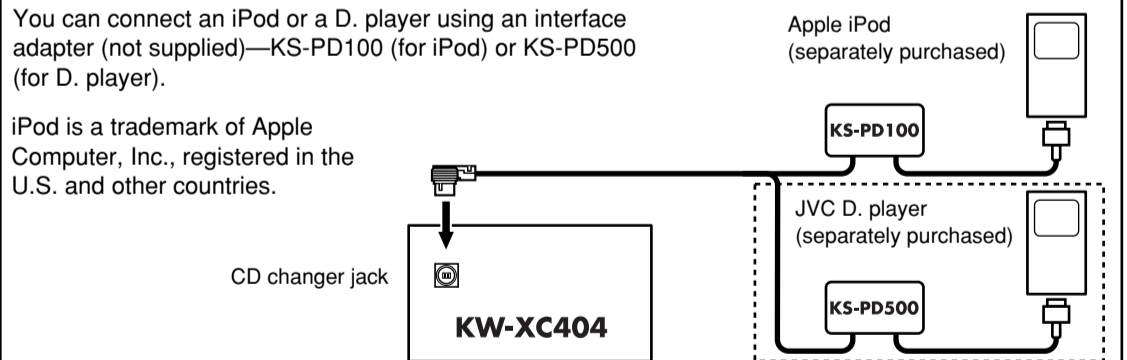

- Set "EXT INPUT" to "EXT INPUT" (see page 21 of the INSTRUCTIONS).

External Component

You can connect an external component using a line input adapter, KS-U57 or KS-U58 (not supplied).

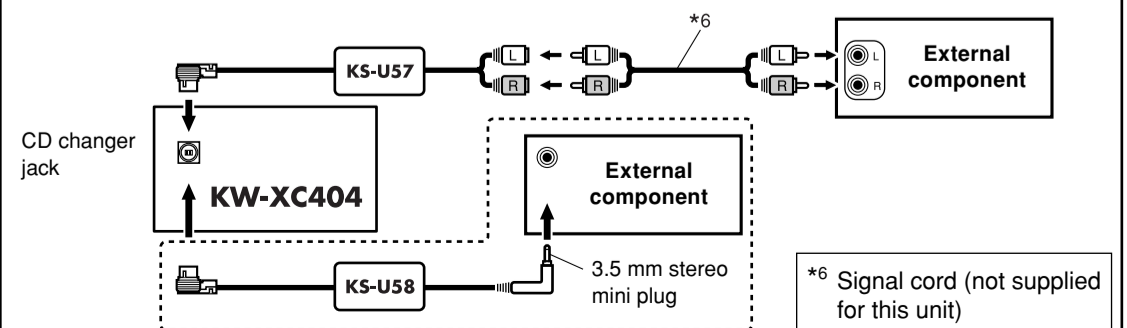

Free Manuals Download Website

<http://myh66.com>

<http://usermanuals.us>

<http://www.somanuals.com>

<http://www.4manuals.cc>

<http://www.manual-lib.com>

<http://www.404manual.com>

<http://www.luxmanual.com>

<http://aubethermostatmanual.com>

Golf course search by state

<http://golfingnear.com>

Email search by domain

<http://emailbydomain.com>

Auto manuals search

<http://auto.somanuals.com>

TV manuals search

<http://tv.somanuals.com>