

SAFETY PRECAUTIONS

Warning Notice FOR YOUR SAFETY (Australia)

1. Insert this plug only into effectively earthed three-pin power outlet.
2. If any doubt exists regarding the earthing, consult a qualified electrician.
3. Extension cord, if used, must be three-core correctly wired.

IMPORTANT (In the United Kingdom) Mains Supply (AC 230 V) WARNING – THIS APPARATUS MUST BE EARTHED

The wires in this mains lead are coloured in accordance with the following code;

GREEN-and-YELLOW : EARTH
BLUE : NEUTRAL
BROWN : LIVE

As the colours of the wires in the mains lead of this apparatus may not correspond with the coloured markings identifying the terminals in your plug, proceed as follows.

The wire which is coloured GREEN-AND-YELLOW must be connected to the terminal in the plug which is marked with the letter E or by the safety earth symbol \perp or coloured GREEN or GREEN-AND-YELLOW.

The wire which is coloured BLUE must be connected to the terminal which is marked with the letter N or which is coloured BLACK. The wire which is coloured BROWN must be connected to the terminal which is marked with the letter L or coloured RED.

POWER SYSTEM

Connection to the mains supply

This unit operates on voltage of 220 V to 240 V AC, 50 Hz/60 Hz.

WARNING:

TO REDUCE THE RISK OF FIRE OR ELECTRIC SHOCK, DO NOT EXPOSE THIS APPLIANCE TO RAIN OR MOISTURE.

CAUTION

To prevent electric shock, do not open the cabinet. No user serviceable parts inside. Refer servicing to qualified service personnel.

Note:

The rating plate and the safety caution are on the rear of the unit.

The OPERATE button does not completely shut off mains power from the unit, but switches operating current on and off.

WARNING

It should be noted that it may be unlawful to re-record pre-recorded tapes, records, or discs without the consent of the owner of copyright in the sound or video recording, broadcast, or cable programme and in any literary, dramatic, musical or artistic work embodied therein.

CAUTION

RED colour indications on the operation panel are provided but they are not safety related, RED colour indications:

- (1) For Recording Button.

Caution for AC Power Cord

FOR YOUR SAFETY PLEASE READ THE FOLLOWING TEXT CAREFULLY.

Appropriate AC Power Cord must be used in each local area.

FOR CONTINENTAL EUROPE, ETC.

Not to be used in the U.K.

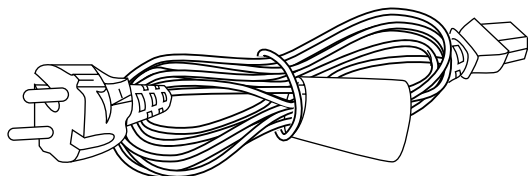

FOR U.K. ONLY

If the plug supplied is not suitable for your socket outlet, it should be cut off and appropriate one fitted.

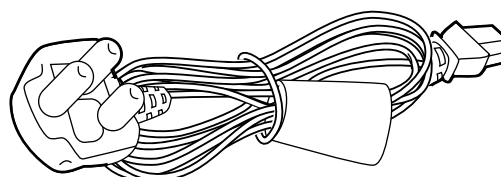

SAFETY PRECAUTIONS

WARNING

This is a Class A product. In a domestic environment this product may cause radio interference in which case the user may be required to take adequate measures.

■ Place of storage and use

Please avoid storing or using this DVR in the following places:

- Extremely hot or cold places beyond the allowable temperature for operation (5°C - 40°C).
- Humid or dry places beyond the allowable humidity range for operation (30 % - 80 % RH).
- Dusty or sandy places.
- Places exposed to oil, smoke or steam, such as the kitchen vicinity.
- Vibrating or unstable places.
- Places prone to condensation.
- Places that generates strong magnetic fields, e.g., transformer or motor.
- Places near devices that generate electric waves, e.g., transceiver or mobile phone.
- Places that generate radiation, X-rays or corrosive gases.

■ Handling the unit

- Please do not place heavy objects on the DVR, like a monitor or TV.
- Please do not block the ventilation openings.
- Avoid violent shocks to the unit. Do not drop the unit.

WARNING

For PLUGGABLE EQUIPMENT, the socket outlet shall be installed near the equipment and shall be easily accessible.

■ Maintaining the unit (Please turn off the power before performing maintenance work.)

Please wipe the unit with a soft cloth. Do not wipe it with thinner or benzene lest the surface melts or becomes dull. For stubborn stains, wipe first with a water-diluted neutral detergent and then wipe dry.

■ Please use the supplied power cord. Using a different type or damaged cord may cause fire or electric shock.

■ Hard-disk

The hard-disk is a consumable item. Replacement is recommended after 10000 hours of use (if use in a 25°C environment). For information on maintenance planning and costs, consult your nearest JVC dealer.

■ To save energy, be sure to turn off the system when not in use.

How to read the Instruction manual (pdf file)

[ENGLISH]

1. Insert the provided CD-ROM into PC, click [AdobeRdr60_enu.exe] in the "AdobeReader" folder to install AdobeReader 6.0.
2. Double-click the [VR-716E_en.pdf] in the "VR-716E_Manual" folder to read the file.

[DEUTSCH]

1. Legen Sie die beiliegende CD-ROM in das CD-ROM-Laufwerk Ihres Computers. Öffnen Sie den Ordner "AdobeReader" auf der CD-ROM und doppelklicken Sie auf das Programm [AdobeRdr60_deu.exe], um den Adobe Acrobat Reader 6.0 zu installieren.
2. Doppelklicken Sie dann auf die Datei [VR-716E_de.pdf] im Ordner "VR-716E_Manual", um die Bedienungsanleitung zu öffnen.

[FRANÇAIS]

1. Placez le CD dans le lecteur et cliquez sur [AdobeRdr60_fra.exe] dans le dossier "AdobeReader" pour installer AdobeReader 6.0.
2. Double-cliquez sur [VR-716E_fr.pdf] dans le dossier "VR-716E_Manual" pour lire le fichier.

[ESPAÑOL]

1. Introduzca el CD-ROM proveído en el PC, haga click en [AdobeRdr60_esp.exe] en la carpeta "AdobeReader" para instalar el AdobeReader 6.0.
2. Haga doble click en [VR-716E_es.pdf] en la carpeta "VR-716E_Manual" para leer el fichero.

[ITALIANO]

1. Inserire il CD-ROM allegato nel PC, fare clic su [AdobeRdr60_ita.exe] nella cartella "AdobeReader" per installare 6.0.
2. Fare doppio clic su [VR-716E_it.pdf] nella cartella "VR-716E_Manual" per leggere il file.

Table of Content

Getting Started

Table of Content	4
Main Features	5
Precautions	6
Names and Functions	7

Installation and Preparation

System Connection (When Connecting 16 Cameras)	14
Mounting to a Rack	15
Turning On/Off the Power	15
Setting the Date/Time	16
Onscreen Display	19

Menus

Menu Flow Chart	20
Changing Menu Settings	22

Routine Uses

Viewing Live Camera Images

- When connecting the monitor to the [EE OUT] terminal ... 32
- When connecting the monitor to the [VIDEO OUT] terminal 33 |
- Setting Time Interval for Switching Displays in the Single Picture Mode 34 |
- Setting Time Interval for Switching Displays in the Quad Picture Mode 35 |

Recording Camera Images

- Recording in the Normal Mode 36 |
- Repeat Recording (Repeat Record Feature) 37 |

Viewing Recorded Images

- Playing Back Recorded Images 38 |
- Viewing Recorded Images in the Split Screen Mode 39 |
- Searching Image According to Date/Time ("DATE/TIME SEARCH") 40 |
- Searching Image According to Alarm/Sensor Data ("ALARM/SENSOR SEARCH") 41 |
- Adjusting Playback Speed (Jog/Shuttle Playback) 42 |
- Viewing Recorded Images in the Skip Mode 43 |
- Enlarging the Still Image (Still Image Zoom) 44 |

Record Programming Using the Program Timer

- Weekly Timer (For starting recording on a specific day and time on a weekly basis) 46 |
- Weekly Timer (For starting recording on a specific time of the day) 48 |
- Weekly Timer (For starting recording on a specific day of the week and time) 50 |
- Date Timer 52 |
- Canceling a Record Program 54 |
- Changing a Record Program 54 |

Useful Features

- Hard Disk Maintenance 55 |
- Defrag 57 |
- Initializing the Hard Disk ("FORMAT") 58 |
- Hard Disk Mirroring 59 |
- To view the list of Power Outage Recovery Records 60 |
- Series Recording Using 2 or More VR-716 Recorders 61 |
- Activation of Recording Via External Signals 61 |
- External Hard Disk Drives 62 |
- Hard Disk Recovery Feature 63 |
- Copying to DVD-RAM 64 |
- Activation of Recording Via External Alarm/Sensor Signals 66 |
- Using the Motion Detect Feature 68 |
- Motion detect check mode and setting guidance 70 |
- Continuing with Recording Upon Recovery from Power Failure 71 |
- Setting a Title for Each Camera Channel Screen 72 |

Connecting to a PC

What is a Web Browser?

You can do the followings	73
Cautions for Proper Use of the Web Browser	74
Setup Flow	75

Connecting to a Web Browser and Setting Up

Connecting Using a LAN Cable	76
Setting Up a Network for VR-716	77
Setting Up a PC Network	
• When Using Windows XP	78
• When Using Windows 2000	79
Connecting (Login) to the Network	81

Routine Uses of the Web Browser

Setting a Title for Each Camera Channel Screen	82
Record Program Using the Program Timer	83
• Setting Screen	83
• Start recording on a specific time of the week	84
• Start recording at a specific time everyday	85
• Start recording on a specific day and time	86
• Start recording at a specific date	87
Setting VR-716 to the Program Timer Standby Mode	88
Checking Recording Operation After Release Timer is Executed	89
Changing/Deleting Record Programs in the Program Timer	90
Searching Image According to Date/Time (Event Search)	
• Searching Alarm/Sensor recording	91
• Search By Date/Time	92
• Search By Term	93

Useful Browser Features

Restricting Access to VR-716	94
Restricting Access to Recorded Image Files at VR-716	95
Changing Network Settings of VR-716 from PC	96
Mail Notification Setting During Alarm/Sensor Input	97
Viewing Images of Event Search Results (Simple Viewer)	99
Saving VR-716 Settings to a File	101
Uploading VR-716 Settings	103
Information About Open Source Software	104

Explanations

Troubleshooting

- Problems Related to Error Code and Onscreen Display 105 |
- Other Problems 106 |
- Troubleshooting on Use of Browsers 107 |

Web Browser Glossary

Recording Mechanism

- Normal Recording 111 |
- Repeat Record 112 |
- Presensor Recording 113 |

Skip Jump

Recording Duration

RS-232C Connection

Notes related to Summer Time

Others

Specifications	117
----------------------	-----

Getting Started

Thank you for
purchasing this VR-716E
Digital Video Recorder.

In the subsequent sections of this manual, this equipment shall be referred to as VR-716.

Main Features

- ✓ **Built-in hard disk drive with a high capacity of 160 GB**
- ✓ **Simultaneous recording of 400 images / sec in 16 channels**
Recording up to 400 images/second.
- ✓ **Simultaneous Playback mode**
Playback, jog/shuttle playback and skip play are possible during recording.
- ✓ **Monitor with display in quad or 16 split pictures**
16-channel video input can be displayed in quad or 16 pictures at 25 images per second on the monitor.
- ✓ **Direct search on the screen**
Searches quickly for the date/time and alarm position to invoke.
- ✓ **Recovery Recording during power outage**
Upon recovery from a power outage that occurred during recording, VR-716 will resume recording in the mode prior to the failure.
- ✓ **Timer Recording**
Daily/Weekly timer recording up to 8 programs.
- ✓ **Alarm/Sensor Recording**
Switches automatically to the Alarm Recording mode as set in the menu when alarm signals are received during recording.
- ✓ **Supports 16-channel asynchronous camera inputs**
Simultaneous recording/playback of images in 16 asynchronous cameras.
- ✓ **Network-compatible**
Recorded images can be viewed on LAN-connected computers. Titles and timer programs can also be set using computers.
- ✓ **Motion Detect**
Automatically detects image motion within the specified area and starts alarm recording.
- ✓ **Digital Water Mark**
Embeds data in images to protect data integrity against falsification and unauthorized detection during data replication.
- ✓ **Transmission of alarm e-mails**
E-mails can be sent out to any computers during alarm (sensor) input.

How to Use the Operation Lock

VR-716 employs a secret operation lock system to prevent its power from being turned off by mistake or tampering with the record functions. When the operation lock is turned ON, the lock operation can be selected as either "ALL" or "STOP REC" from the menu.

PG 25 'OPERATION LOCK'

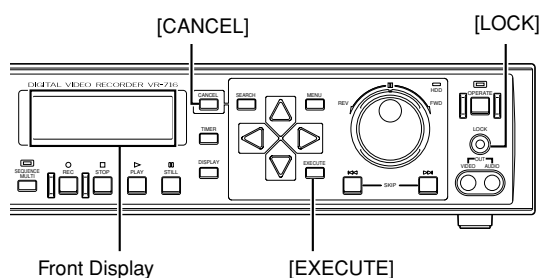

For security reasons, it is recommended that you detach this page and keep it separately.

■ Turning On the Operation Lock

Press the [LOCK] and [EXECUTE] buttons simultaneously.

- This locks the operation immediately and keys are disabled. (However, this does not apply to control via Web browsers.)
- [LOCK] is indicated on the front display.

■ Turning Off the Operation Lock

Press the [LOCK] and [CANCEL] buttons simultaneously.

- This deactivates the operation lock.

Getting Started (continued)

Precautions

- Do not stack up the equipment to prevent temperature within from rising.
- Do not stand this equipment vertically during use.
- Handle this equipment with care. Do not subject it to physical shock.
- Do not expose the equipment to physical shock during transport. In particular, do not move the equipment during recording or playback.
- This product utilizes the open source software. Refer to the instruction on page 104 to display the precise information.
- If a power failure occurs during formatting of hard disk, disconnection, or when configuring or disabling mirroring, operation of the equipment may be disabled even if it is connected to the UPS.
- Do not insert foreign object into this unit as this may cause malfunction or electric shock.
- A longer time may be required to search through data stored in this equipment if the volume is too huge. This is not a defect.
- Do not use the power cord supplied with this equipment on other devices.
- Please note that we will not provide compensation for any failure during recording or playback due to defects in this equipment or the hard disk drive.
- TV broadcast or other video (audio) recordings are for personal use only. Unauthorized use of these materials is strictly prohibited.
- Please note that recorded images will be erased when replacing hard disks or upgrading firmware.
- The width of the borders on split screens (dark portion) may vary according to the type of input signal. This is a characteristic of this equipment and is not a defect.

How to Read this Manual

■ Symbols used in this manual

Caution

States precautions to be taken during operation.

Note

States restrictions on the functions or use of this equipment. For reference purposes.



Indicates the page numbers or items to refer to.

■ The names of buttons used during operation are enclosed in [].

Example: MENU button → [MENU]

※ All product names stated in this manual are trademarks or registered trademarks of their respective companies. Marks such as TM, [®] and © are omitted in this manual.

Names and Functions (Front)

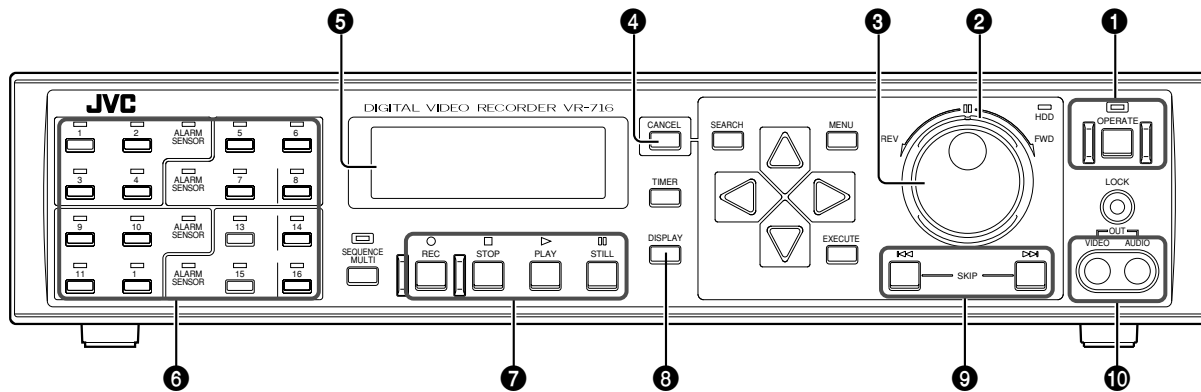

1 [OPERATE] Button and Operate LED

To turn off the power, press the button continuously for about 2 seconds.

☞ Page 15 'Turning On/Off the Power'

2 Shuttle Dial

When in the Play or Still mode, turn this to adjust the playback speed.

☞ Page 42 'Adjusting Playback Speed'

3 Jog Dial

When in the Play or Still mode, turn this to enable single frame playback. Use this to select the preset values when a menu screen is displayed.

☞ Page 42 'Adjusting Playback Speed'

4 [CANCEL] Button

- Use this to delete Program Timer settings or a record program.

☞ Page 54 'Canceling a Record Program'

- Press this to turn off the alarm/warning LED or the buzzer when an alarm/warning is activated.

5 Front Display

Displays the operational state and settings of the digital video recorder.

☞ Page 12 'Front Display'

6 Camera Selection Buttons and LEDs

For selecting the camera channel to which output from the [VIDEO OUT] on the front panel 10 or rear panel 28 (☞ Page 9) is sent. The LED of the channel selected will light up in green. The LED of the channel that received an alarm input will light up in red. It will light up in orange when the channel that received an alarm input is selected. The LED of the channel will blink in green when a camera is not connected. It will blink in orange when there is an alarm input and the camera is not connected.

It is also used to switch between display in quad picture and single picture during playback of recorded video images.

☞ Page 23 "FDP" Menu → 'INPUT SIGNAL ERROR'

☞ Page 39 'Viewing Recorded Images in the Split Screen Mode'

7 Manual Operation Buttons

• [REC] Button

Press this button when in the Stop or Play mode to start recording. Recording mode can be specified on the menu screen.

☞ Page 36 'Recording Camera Images'

• [STOP] Button

Press this button to stop playing. Press this button when in the Simultaneous Record/Play mode to stop playing and switch to the normal recording mode.

• [PLAY] Button

Press this button to start playing.

- Pressing this button when in the Stop mode:

Starts playing from the point at which the previous playback ended.

- Pressing this button when in the Recording mode:

Starts playing back while in the Recording mode. (Simultaneous Record/Play)

☞ Page 38 'Viewing Recorded Images'

Note

• Playback immediately after the [OPERATE] button is turned ON either starts from the point or pauses at the point where the last recording has ended depending on the frame rate setting.

• [STILL] Button

Press this button when in the Play mode to switch to the Still mode.

8 [DISPLAY] Button for Switching Front Panel Display

Press this button to switch between clock, date, remaining hard disk space and record setting (record quality, frame rate, audio) displays.

☞ Page 13 'Front Display'

9 [SKIP] Search Buttons

Press this button when in the Stop mode to jump to the beginning of a start or end point of a recording in the hard disk.

Press this button when in the Play mode to Skip Jump.

There are 3 Skip Jump modes:

- "TIME" Jump : Jumps in fixed time intervals when button is pressed.
- "EVENT" Jump : Jumps to the starting point of events when button is pressed.
- "ALARM" Jump : Jumps to the starting point of alarm recording when button is pressed.

☞ Page 114 'Skip Jump'

10 [VIDEO OUT] / [AUDIO OUT] Terminals (RCA)

Outputs recorded video and audio when in the Play mode. Outputs inputted video and audio when in the Recording or Stop mode.

Note

• Audio signals will not be output during playback if the frame rate of video images is set as "1/6 IPS" (1 image per 6 seconds) or "1/12 IPS" (1 image per 12 seconds) in the "FRAME RATE" item (☞ Page 24) of the "REC MODE" Menu.

Getting Started (continued)

Names and Functions (Front)

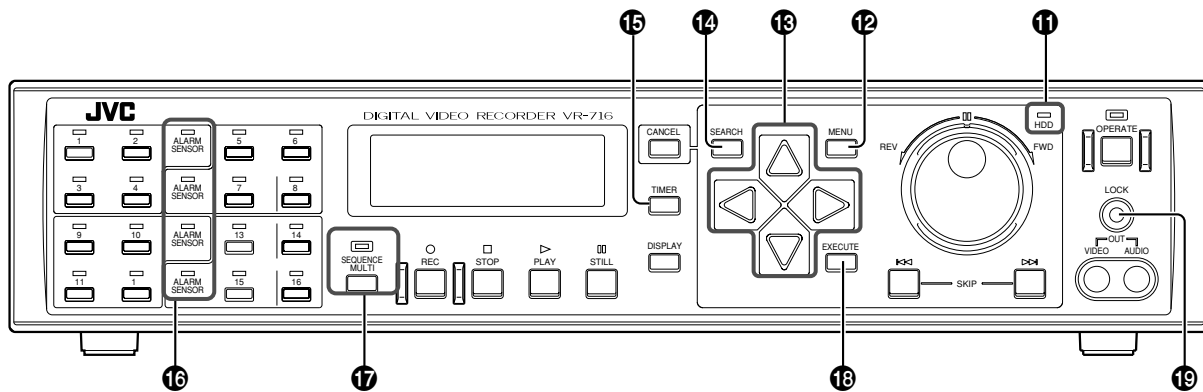

11 [HDD] LED

Lights up when the built-in hard disk drive is in operation.

12 [MENU] Button

Press this button to display the menu screen or to return from the menu to the main screen.

☞ Page 22 'Changing Menu Settings'

13 Cursor Control Buttons

When the menu or search screens are displayed, use these buttons to move the cursor. Otherwise, these are used to change the onscreen display positions of the date or title.

☞ Page 19 'Onscreen Display'

14 [SEARCH] Button

Button for displaying the "SEARCH MENU". Press this button to perform alarm search or date/time search. Press again to return to the main screen.

☞ Page 40 'Searching Image According to Date/Time'

15 [TIMER] Button

Press this button to switch to the Standby mode after setting in the "PROGRAM TIMER" is completed. Press again to disable the Standby mode.

When this button is pressed before setting the Program Timer, the buzzer will be activated and the [TIMER] indicator on the front display will start to blink.

The ON/OFF of BUZZER depends on the "WARNING" setting in the "BUZZER" Menu.

☞ Page 24 'BUZZER Menu'

☞ Page 46 'Record Programming Using the Program Timer'

16 [ALARM SENSOR] LED

Blocks (every 4 entries) that are in the Alarm Recording Standby or Sensor Recording Standby modes will light up in green.

17 [SEQUENCE MULTI] / Split Screen Display Switching Button and LED

Press this button to change the display in the following ways:
16 Split → Single Picture Automatic Switching → Quad Picture Automatic Switching

When quad picture or 16 split are displayed, the LED lights up in orange. This is indicated in green when in the single picture automatic switching or quad picture automatic switching. Does not function when in the Play mode.

☞ Page 33 'When Connecting the Monitor to the [VIDEO OUT] terminal'

18 [EXECUTE] Button

Use this button to perform alarm search or date/time search as well as to execute hard disk scanning or formatting or to perform other operations.

☞ Page 40 'Searching Image According to Date/Time'

☞ Page 58 'Initializing the Hard Disk ("FORMAT")'

19 [LOCK] Button

Press and hold this button followed by pressing the [STOP] button to adjust the seconds of the clock.

- When the value is 29 seconds or less, this will be reset to 00 seconds with the minute value unchanged.
- When the value is 30 seconds and above, this will be reset to 00 seconds with the minute rounded to the next higher value.

Names and Functions (Rear)

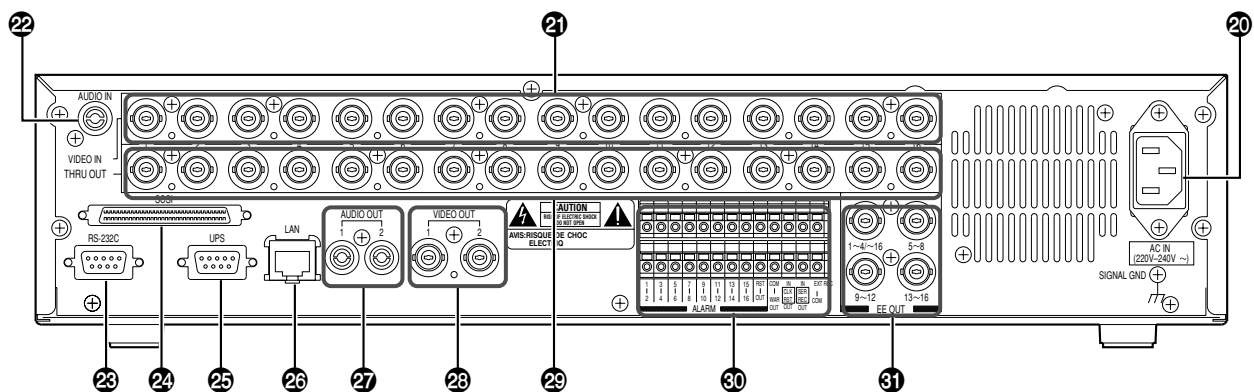

- 20 [AC IN (220 V - 240 V ~)] Power Inlet**
Connect using the power cord supplied to an AC 220 V - 240 V outlet. The main unit will turn on automatically when connected.
☞ Page 15 'Turning On/Off the Power'
- 21 [VIDEO IN] Camera Image Signal Input (BNC)**
Connect this to the video output of the video camera (sold separately).
- 22 [AUDIO IN] Terminal (RCA)**
Connect this to the audio output of the device for which audio recording is to be performed.
- 23 [RS-232C] Remote Terminal (D-sub 9 Pin)**
VR-716 can be controlled externally by connecting it to a computer.
- 24 [UPS] Terminal (68-pin Ultra Wide SCSI)**
For connection to external hard disk drive (sold separately) and DVD-RAM drive (sold separately).
- 25 [UPS] Uninterruptible Power Supply Control Terminal (D-sub 9 Pin)**
For connection to the communication control connector of the UPS unit. For more details, please consult the outlet from which this equipment is purchased.
- 26 [LAN] Connection Interface (100 Base-T)**
For connection to the Intranet and other networks using a LAN cable.
☞ Page 76 'Connecting Using a LAN Cable'
- 27 [AUDIO OUT 1, 2] Terminals 1 and 2 (RCA)**
Outputs the audio input when in the Recording or Stop mode.
Outputs recorded audio when in the Play mode. However, there will be no audio output in the following circumstances:
- When playing back recorded images for which the frame rate is set as "1/6 IPS" (1 image per 6 seconds) or "1/12 IPS" (1 image per 12 seconds) in the "FRAME RATE" menu switch.
 - When performing search other than x 1 mode or during Still or single frame playback.
 - When playing back images with the "AUDIO REC" item in the "REC MODE" menu selected as "OFF" during recording.
 - When the "MAIN MENU/OPERATION MENU" or "SEARCH MENU" is displayed in the Play mode.
- 28 [VIDEO OUT 1, 2] Terminals 1 and 2 (BNC)**
Outputs images selected using the Camera Selection Buttons **6** on the front panel.
- 29 [THRU OUT] Camera Image Output Terminal (BNC)**
Outputs camera image signals that correspond to each [VIDEO IN] terminal **21**. For connection to TV monitors. (Automatic termination)
- 30 [Signal Input/Output Terminal]**
For operating VR-716 using external alarm/sensor signals or signals received from external devices, or for operating external devices by outputting signals.
☞ Page 10 'Names and Functions (Signal In/Out Terminal)'
- 31 [EE OUT] (BNC)**
Outputs the live images on cameras connected to the [VIDEO IN] terminals **21** in quad picture.
The [1-4 / -16] connector can also be used to output images in 16 split pictures.
☞ Page 32 'When Connecting the Monitor to the [EE OUT] terminal'

Getting Started (continued)

Names and Functions (Signal In/Out Terminal)

(Rear)

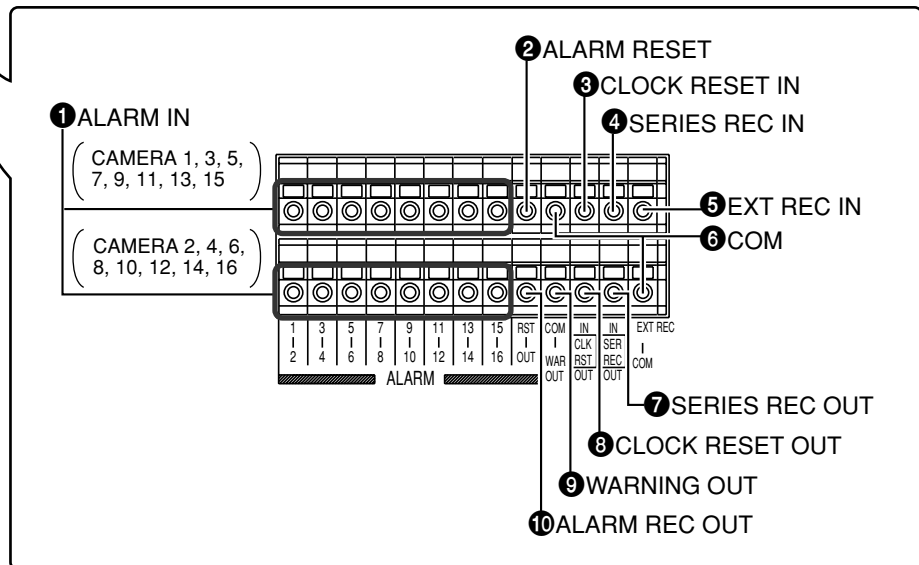
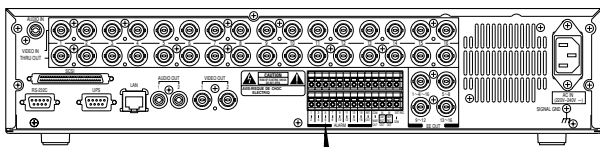

1 [ALARM IN] Terminal (Supports Channels 1 - 16)

Terminal that accepts input signals to start alarm or sensor recording.

2 [ALARM RESET] Input Terminal

Terminal that accepts signals to stop recording during alarm or sensor recording.

3 [CLOCK RESET IN] Terminal

For connection to a master clock or the [CLOCK RESET OUT] terminal of other devices. This equipment can be set to a master clock or the clock of other devices upon the input of clock reset signals.

The clock in VR-716 will be reset as follows upon the input of clock reset signals:

- When the value is 29 seconds or less, this will be reset to 00 seconds with the minute value unchanged.
- When the value is 30 seconds and above, this will be reset to 00 seconds with the minute rounded to the next higher value.

☞ Page 61 'Series Recording Using 2 or More VR-716 Recorders'

4 [SERIES REC IN] Terminal

Series recording will start upon the input of [SERIES REC OUT] signals. This is the terminal that accepts the series recording signals of other VR-716s when multiple sets of VR-716 are used.

☞ Page 61 'Series Recording Using 2 or More VR-716 Recorders'

5 [EXT REC IN] Terminal

Starts recording automatically upon receiving external signals when the "EXT REC MODE" is set as "TRIGGER" or "MANUAL".

☞ Page 25 'OPERATION/EXT REC Menu'

☞ Page 61 'Activation of Recording Via External Signals'

6 [COM] Common Ground Terminal

This is a common ground terminal. For connection to the signal ground terminal of other devices.

7 [SERIES REC OUT] Terminal

Outputs signals when the remaining hard disk space is 1 % or less.

However, there will be no signal output in the following circumstances:

- When the "SERIES REC" item is set as "OFF" in the menu.

☞ Page 25 'OPERATION/EXT REC Menu'

☞ Page 61 'Series Recording Using 2 or More VR-716 Recorders'

8 [CLOCK RESET OUT] Terminal

Terminal for output of clock reset signals. Signals are output in the following cases:

When the internal clock of VR-716 turns 00:00 or 12:00.



☞ Page 61 'Series Recording Using 2 or More VR-716 Recorders'

9 [WARNING OUT] Terminal

Outputs signals during hard disk malfunction or error occurrence. (☞ Page 105)

10 [ALARM REC OUT] Terminal

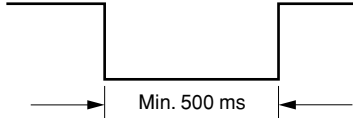
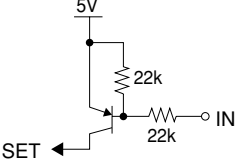
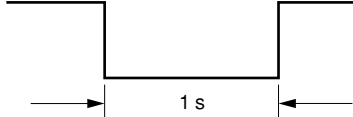
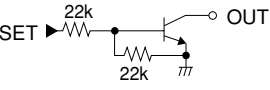
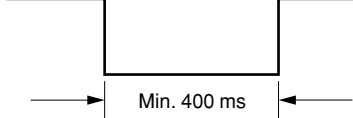
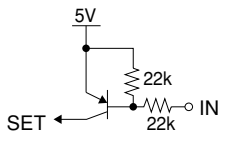
Outputs signals when VR-716 is in the Alarm Recording or Sensor Recording mode.

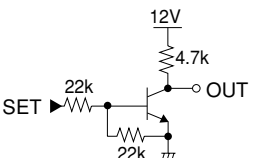
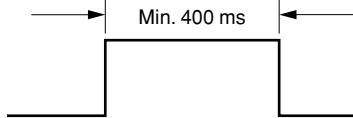
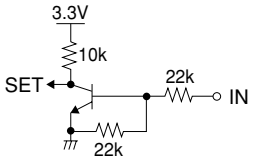
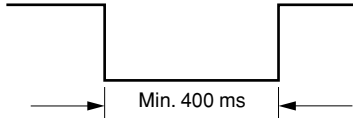
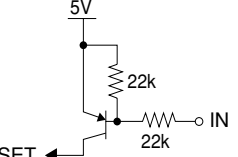
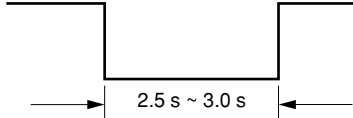
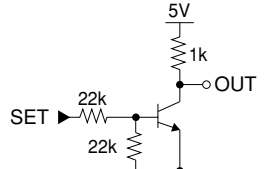
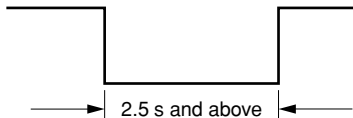
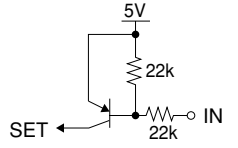
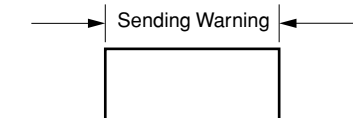
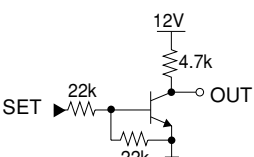
Terminal	Signal Level	Remarks
[CLOCK RESET IN]	 <p>High Voltage = 5 V Low Voltage = 0 V</p> <p>Min. 500 ms</p> <p>※ Ensure that the impedance at the output is 10 kΩ or less.</p>	<p>Grounded Input (44 kΩ)</p> 
[CLOCK RESET OUT]	 <p>High Voltage = 5 V Low Voltage = 0 V</p> <p>1 s</p>	<p>Open Collector</p> 
[ALARM IN]	 <p>High Voltage = 5 V Low Voltage = 0 V</p> <p>Min. 400 ms</p> <p>※ Ensure that the impedance at the output is 10 kΩ or less.</p>	<p>Grounded Input (44 kΩ)</p> 
[ALARM REC OUT]	 <p>High Voltage = 12 V Low Voltage = 0 V</p> <p>During Alarm Recording</p>	<p>High Output (4.7 kΩ)</p> 
[ALARM RESET]	 <p>High Voltage = 5 V ~ 12 V</p> <p>Min. 400 ms</p> <p>※ Ensure that the impedance at the output is 10 kΩ or less.</p>	<p>High Input (44 kΩ)</p> 
[EXT REC IN]	 <p>High Voltage = 5 V Low Voltage = 0 V</p> <p>Min. 400 ms</p> <p>※ Ensure that the impedance at the output is 10 kΩ or less.</p>	<p>Grounded Input (44 kΩ)</p> 
[SERIES REC OUT]	 <p>High Voltage = 5 V Low Voltage = 0 V</p> <p>2.5 s ~ 3.0 s</p>	<p>LOW Output (1 kΩ)</p> 
[SERIES REC IN]	 <p>High Voltage = 5 V Low Voltage = 0 V</p> <p>2.5 s and above</p> <p>※ Ensure that the impedance at the output is 10 kΩ or less.</p>	<p>Grounded Input (44 kΩ)</p> 
[WARNING OUT]	 <p>High Voltage = 12 V Low Voltage = 0 V</p> <p>Sending Warning</p>	<p>High Output (4.7 kΩ)</p> 

Getting Started (continued)

Names and Functions (Front Display)

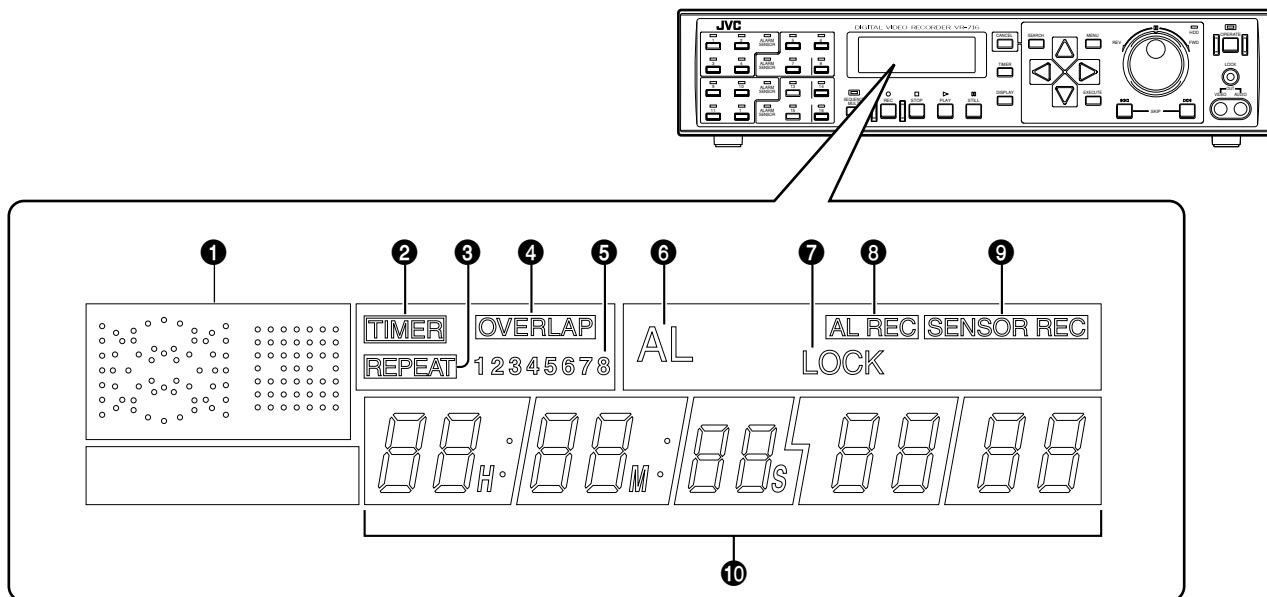

1 Operation Mode Indicator

Displays the operation mode of VR-716.

	Recording Lights up in red.
	Play
	Still
	Fast Forward / Slow Play
	Rewind / Slow Play
	Single Frame Playback ▷ blinks.
	Single Frame Reverse Playback ◁ blinks.
	Simultaneous Playback ▷ and ○ blink alternately.
	Still Mode During Simultaneous Playback ▬ and ○ blink alternately.

2 [TIMER] (Timer) Indicator

Lights up when in the Timer Recording Standby or Timer Recording mode.

☞ Page 46 'Record Programming Using the Program Timer'

3 [REPEAT] (Repeat Record) Indicator

Lights up when VR-716 is set in the Repeat Record mode.

☞ Page 37 'Repeat Recording'

4 [OVERLAP] (Overlap) Indicator

Lights up when there is overlap in the timer recording programs of the Weekly Timer.

5 Weekly Timer Program No.

When the Weekly Timer Recording is activated, the LED of the Program No. for which recording is currently executed will start blinking. When in the Timer Standby mode, the Timer Program No. which has been set will light up. The light goes off upon completion of the timer recording.

6 [AL] (Alarm) Indicator

Lights up during the Alarm/Sensor Recording mode.

Light will start to blink upon completion of alarm/sensor recording.

7 [LOCK] (Lock) Indicator

Lights up when the operation lock is enabled.

8 [AL REC] (Alarm Recording) Indicator

Lights up when in the Alarm Recording Standby mode.

☞ Page 66 'Activation of Recording Via External Alarm/Sensor Signals'

9 [SENSOR REC] (Sensor Recording) Indicator

Lights up when in the Sensor Recording Standby mode.

☞ Page 66 'Activation of Recording Via External Alarm/Sensor Signals'

Names and Functions (Front Display)

⑩ Counter/Setting Display

Press the [DISPLAY] button ⑩ on the front panel to switch between the clock display, date display, remaining space display and record setting display.

■ Clock Display: Example > 12:34:56, 1 March

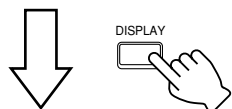

※ When in the Play mode, display of recording time on the playback screen is not possible.

■ Date Display: Example > 1 March 2003 (When "DATE DISPLAY" setting in menu screen is "D/M/Y")

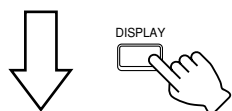

■ Remaining Hard Disk Space Display: Example > 1234 hours left

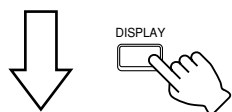
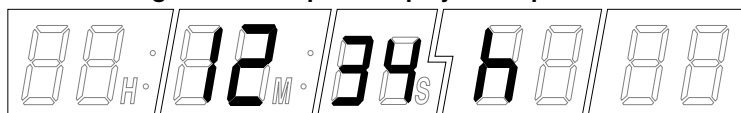

※ Displays the remaining time of continuous recording when in the normal recording mode. Display is not shown during Repeat Recording.

■ "REC MODE" Settings: Example > "BLOCK": "1", "AUDIO REC": "ON", "REC QUALITY": "H", "FRAME RATE": "25"

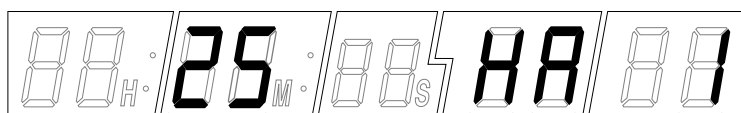

"FRAME RATE"

"REC QUALITY" "AUDIO REC" "BLOCK NO."

"FRAME RATE" is displayed as below corresponding to each setting value in the "REC MODE" Menu (☞ Page 24)

25 IPS → "25"	1.7 IPS → "25/15"
12.5 IPS → "25/2"	1 IPS → "1"
8.3 IPS → "25/3"	1/2 IPS → "1/2"
4.2 IPS → "25/6"	1/6 IPS → "1/6"
2.5 IPS → "25/10"	1/12 IPS → "1/12"

■ "REC MODE" Settings: Example > "BLOCK": "2", "AUDIO REC": "OFF", "REC QUALITY": "L", "FRAME RATE": "1/12"

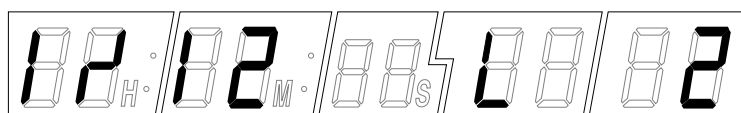

※ Displays the recording conditions of each BLOCK when in the normal recording, Timer Recording or Alarm Recording mode. When in the Stop or Timer Standby mode, however, conditions for each BLOCK during normal recording are displayed. In addition, recording conditions of the images currently being played will be shown with priority when in the Play mode.

■ Error Code Display: Example > Error01

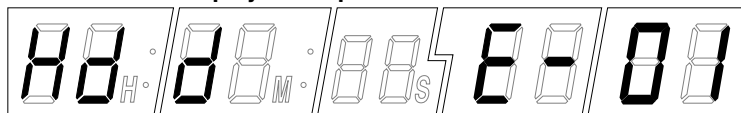

☞ Page 105 'Problems Related to Error Code and Onscreen Display'

Installation and Preparation

System Connection (When Connecting 16 Cameras)

Connection with up to 16 cameras is possible with VR-716's switcher.

<Example>

- Perform recording/playback by connecting to 16 cameras.
- Checking recorded images at Monitor 1 and live camera images on Monitors 2 ~ 5 at the same time.
- Execution of alarm recording upon receiving signals from the alarm sensor.

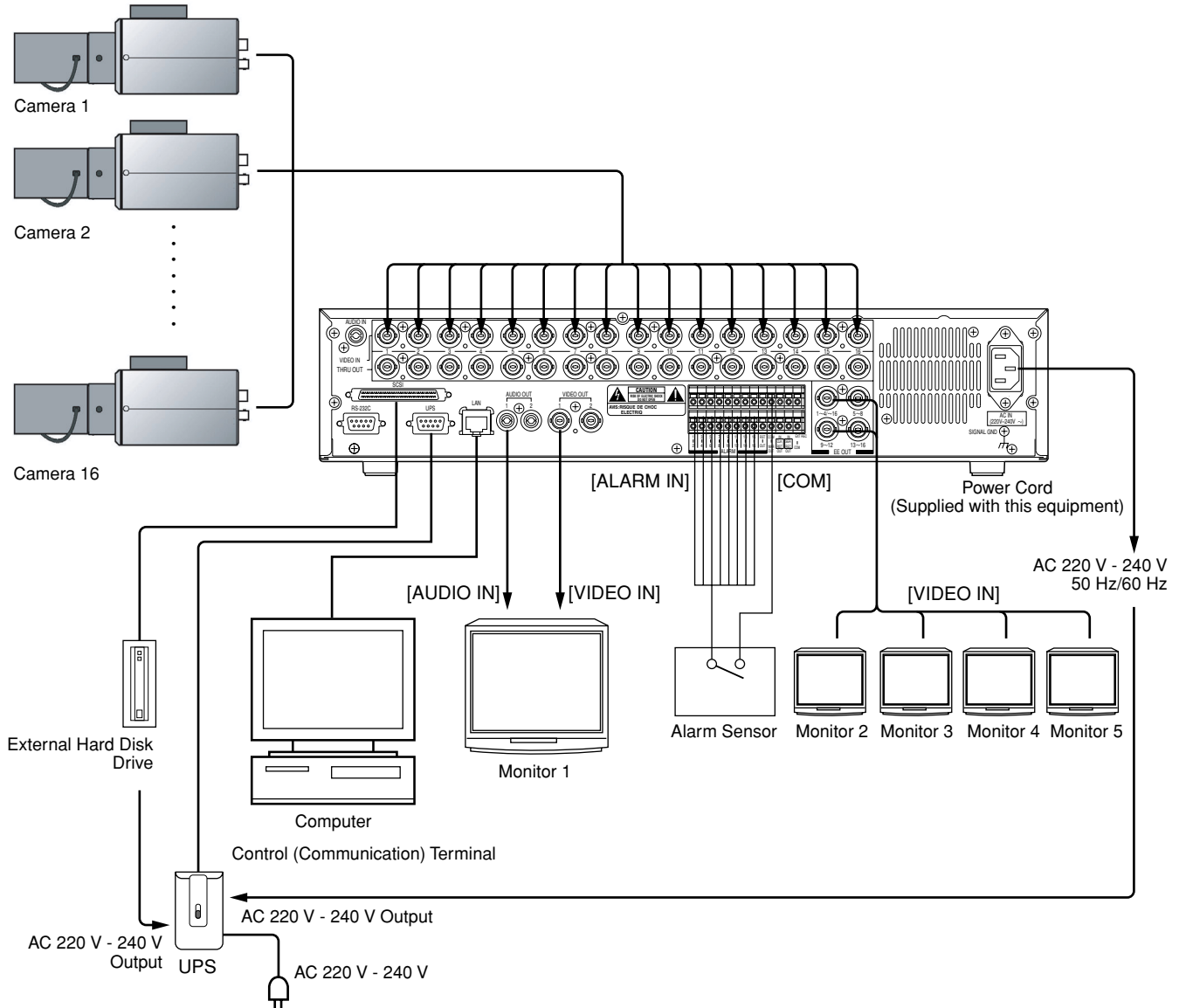

Notes

- Please consult the sales outlet from which this equipment is purchased on the type of UPS units that are compatible with this equipment.
- Consult the outlet from which this equipment is purchased on the types of usable external HDDs.

Caution

- Do not connect CCU's [CAMERA INPUT] to VR-716's [VIDEO IN]. Doing so may damage the input circuit of VR-716.
- When this equipment is connected to CCU, "NO VIDEO IN ** INPUT (E-03)" will be displayed on the screen if error occurs during signal input. (** indicates the Camera No.) Recording cannot be properly performed in such a state at both the camera for which error has occurred as well as at other properly functioning cameras. In this case, set the REC MODE of the camera channel for which error has occurred to "OFF" on the menu, and eliminate the cause of the error immediately.
☞ Page 24 'REC MODE Menu'
- Turn OFF the power of all devices before connecting or disconnecting.
- For channels that are not connected to cameras, set them to "OFF" on the "REC MODE" Menu. ☞ Page 24 'REC MODE Menu'
- When [THRU OUT] is connected with the [BNC] connector, the built-in 75 Ω terminal will be left OPEN. In this case, connect a 75 Ω terminal to the last device.
- For connection of devices other than VR-716, please refer to the respective instruction manuals for details.
- Please refer to Page 73 'Connecting to a PC' for connection with computers.

Mounting to a Rack

Make use of the rack-mounting bracket provided when mounting VR-716 to the EIA rack.

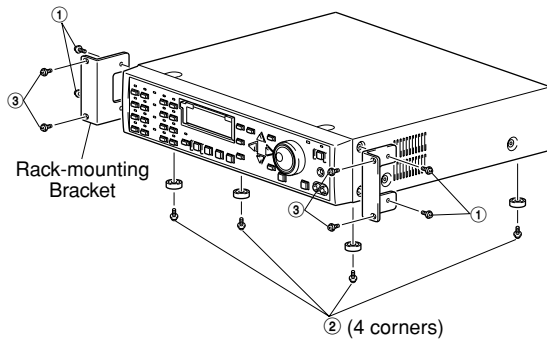

Caution

- Do not place any object on VR-716 that has been mounted onto the rack. This may cause the rack to give way and lead to injuries or equipment damages.
- When mounting 2 or more VR-716 recorders on racks, ensure that they are mounted at least 1 unit away from one another.

1. Mount the rack-mounting bracket to VR-716 using Screw ①

- Fasten the two sides of VR-716 using the 4 screws provided (M4 x 10 mm).

2. Remove Screw ② (4 corners) on the foot stand at the bottom surface of the equipment

- Remove the foot stand.

3. Mount VR-716 to the rack using Screw ③

- Fasten the equipment to the rack using the 4 screws provided (M5 x 10 mm).

Turning On/Off the Power

Notes

- Refer to page 62 'External Hard Disk Drives' when adding external HDDs.
- Operation of power is disabled during system checks. Do so after the "SYSTEM CHECKING... PLEASE WAIT..." display disappears.

Caution

- Turn ON the power of this equipment only after connections with all peripheral devices are completed.
- Do not unplug the power cord when starting up this equipment. This may cause the equipment to malfunction.

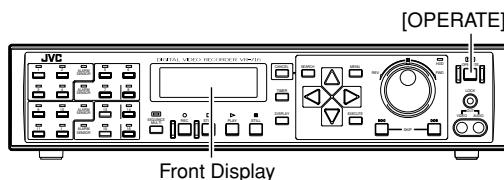

Front Display

Note

- Press the [OPERATE] button once when in the OFF state to turn ON the power.

Caution

- Unplug the power cord only when the power of the equipment is OFF. If the power cord is unplugged when the equipment is in ON state, it will take time to perform a hard disk check when it is turned on again. It may take a long time when the data is fragmented or when there is a large amount of recorded data.

Turning ON the Power

1. Connect the power cord

- Use the power cord supplied to connect to an AC 220 V - 240 V, 50 Hz/ 60 Hz outlet.
- This turns ON the power and starts the system check.

<Monitor>

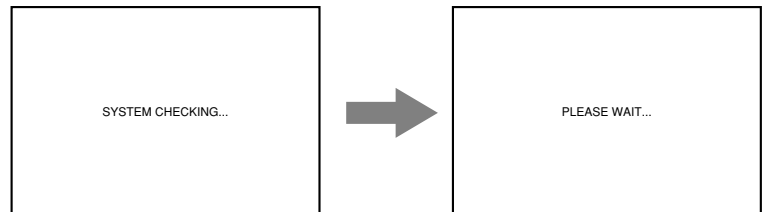

<Front Display>



Turning OFF the Power

1. Press the [OPERATE] button for about 2 seconds

- The front display shows [BUSY] and switches to a dim clock display. (OFF State)



<Front Display>

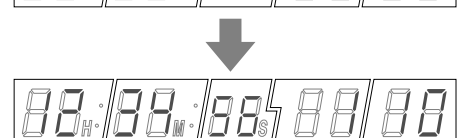

2. Unplug the power cord

Installation and Preparation (continued)

Setting the Date/Time

Onscreen Setting Using the Monitor Screen

Set the date and time on the monitor screen.

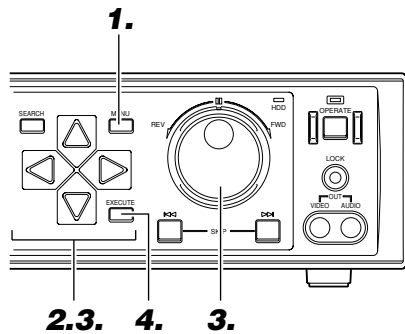

■ TIME ZONE Setting

1. Press the [MENU] button

- This displays the “MAIN MENU/OPERATION MENU” screen on the monitor.



Menu Screen

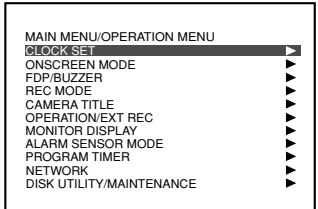

2. Select the “CLOCK SET” item using [▲/▼] and press [▶]

- Move the cursor to select.



3. Press [▼] to move the cursor to “TIME ZONE” and select using the jog dial

- Turn the jog dial to select the region that you reside in.

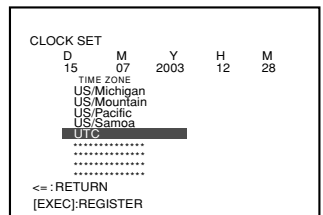
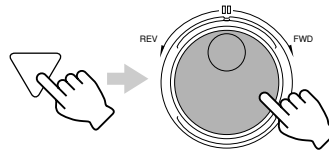

Note

- The order of D/M/Y will change in accordance with the “DATE DISPLAY” setting in the “ONSCREEN MODE” menu.

Caution

- Pay attention when changing dates if the hard disk contains recorded data. Playback, Skip Jump or Direct Jump by Date/Time may not properly function if there is overlap in the recording dates.
- Date/Time setting is disabled when in the Recording mode.
- Refer to the notes related to Summer Time. (Page 116)

4. Press [EXECUTE] to display the confirmation screen

- It will restart automatically and “TIME ZONE” will be set when pressing [EXECUTE] again.



Confirmation screen

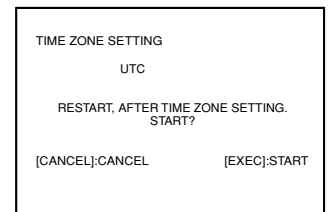

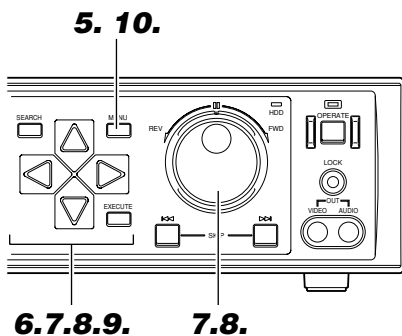

■ Clock Setting

5. Press the [MENU] button

- This displays the "MAIN MENU/OPERATION MENU" screen on the monitor.

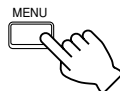

Menu Screen

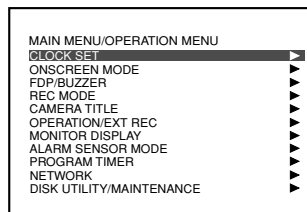

6. Select the "CLOCK SET" item using [▲ / ▼]

- Move the cursor to select.



7. Press [▶] to move the cursor to "CLOCK SET" and turn the jog dial to adjust "D" (Day)

- Turn the jog dial to increase/decrease the value.

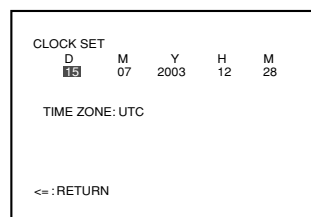
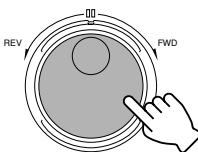

8. Press [▶] and turn the jog dial to adjust "M" (Month)

- Repeat Step 8 to adjust the "Y" (Year), "H" (Hour) and "M" (Minute) values accordingly.

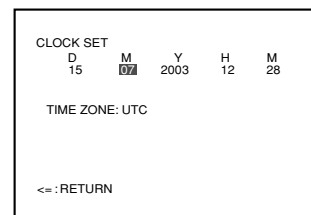
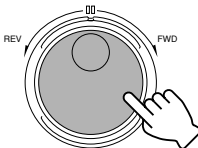

9. Press [▼] to move the cursor to "RETURN"

- Press [◀] to return to the "MAIN MENU/OPERATION MENU" screen.

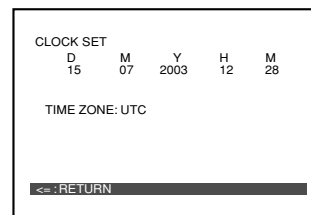

10. Press [MENU] to end setting

- The display returns to the normal screen.

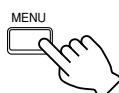

Installation and Preparation (continued)

Setting the Date/Time

Setting Using the Front Display

Set the date/time on the front display of VR-716.

Caution

- Ensure to set the TIME ZONE before setting the Date/ Time.

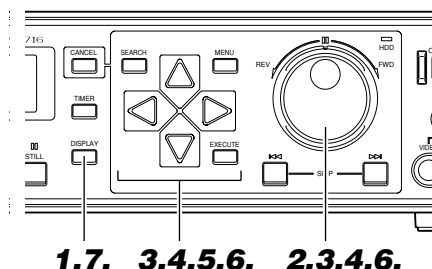

1. Press the [DISPLAY] button for 2 seconds or longer

- The “D” (Day) item on the front display will start to blink.



Note

- Date/Time setting is disabled when VR-716 is in the Recording mode.

2. Turn the jog dial to adjust “D” (Day)

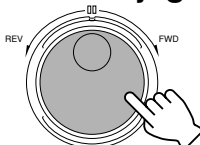

3. Press [▶] to move the blinking cursor to “M” and turn the jog dial to adjust the month

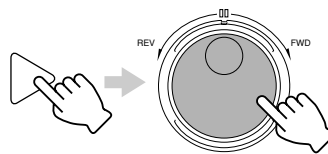

4. Press [▶] to move the blinking cursor to “Y” and turn the jog dial to adjust the year

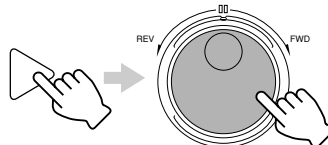

Notes

When adjusting the *seconds*:

- Press and hold the [LOCK] button followed by pressing the [STOP] button to adjust the *seconds* of the clock.
- When the value is 29 seconds or less, this will be reset to 00 seconds with the minute value unchanged.
- When the value is 30 seconds and above, this will be reset to 00 seconds with the minute rounded to the next higher value.
- The order of D/M/Y will change in accordance with the “DATE DISPLAY” setting in the “ONSCREEN MODE” menu.

Caution

- Pay attention when changing dates if the hard disk contains recorded data. Playback, Skip Jump or Direct Jump by Date/Time may not properly function if there is overlap in the recording dates.
- The “TIME ZONE” item cannot be altered on the front display.
- Refer to the notes related to Summer Time. (Page 116)

5. Press the [▶] button

- The hour and minute values will be displayed on the front display but only the hour value blinks.



6. Adjust “H” (Hour) and “M” (Minute)

- Repeat Steps 3 ~ 4 to adjust the hour and minute values.



7. Press the [DISPLAY] button

- This sets and starts the clock.

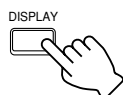

Onscreen Display

VR-716 allows the onscreen display of Date/Time, Alarm (Sensor) No. and the operational state on the monitor.

Changing Position of Onscreen Display

<Onscreen Display>

Labels in the diagram: Day-Month-Year, Day of the Week, Time (24-hour Display), Alarm (Sensor) Detection (Blinks), Playback Direction (Operational State), Alarm (Sensor) No., Camera Title, Remaining Hard Disk Space (Blinks when reached 0%), SLOW.

Example text in the diagram: 01-03-2003 SA 12:34:56 AL-3 60% AL-3

- Alarm (Sensor) No. display includes the following:
 - [AL] : The largest alarm (sensor) no. registered
 - [AL *] : Alarm (Sensor) No. of playback image
 - [AL * P] : Presensor No. of playback image
- Onscreen display settings can be specified on the "ONSCREEN MODE" Menu. (☞ Page 23)

Notes

- When in the Onscreen Display Position Adjustment mode, background of the 'Date/Time Display' and 'Title Display' will appear in blue alternately every time the [EXECUTE] button is pressed. Alteration of display position is possible when the background is shown in blue.
- Priority will be given to the 'Date Time Display' if it overlaps with the 'Title Display'.

<Adjustment of Onscreen Display Position When in Quad Picture>

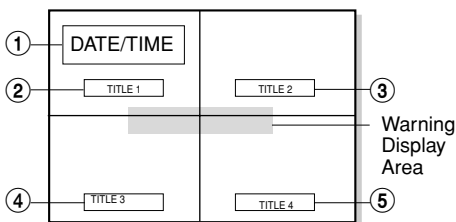

- Press and hold the [EXECUTE] button for a while when in Quad Picture to switch to the Onscreen Display Adjustment Screen as shown in the above diagram.
- Adjust display position in the same way as described in Steps 1 ~ 5.
- Background of the respective displays will turn blue in the following order every time when the [EXECUTE] button is pressed:
 - "DATE/TIME"
 - "TITLE 1"
 - "TITLE 2"
 - "TITLE 3"
 - "TITLE 4"
- The 'Date/Time Display' and 'Title Display' cannot be moved to the Warning Display Area.
- Camera titles are not shown during display in 16 split pictures.

1. Press and hold the [EXECUTE] button for a while

- The monitor screen switches to the Onscreen Display Position Adjustment mode.
- Background color of the 'Date/Time Display' turns blue.

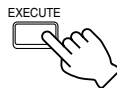

Press and hold

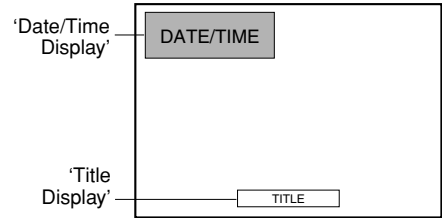

2. Move using the [△ / ▽ / ◀ / ▶] buttons

- The position can be moved diagonally by pressing buttons simultaneously.
- Move the 'Date/Time Display' to any position.
- However, it cannot be shifted to the 'Warning Display Area'.

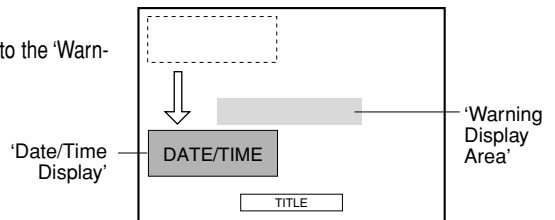
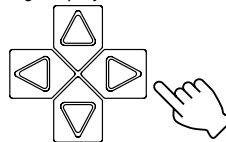

3. Press the [EXECUTE] button

- The 'Title Display' turns blue and is now in the Onscreen Display Position Adjustment mode.

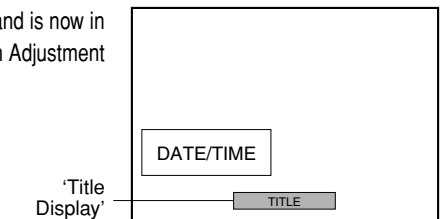

4. Move using the [△ / ▽ / ◀ / ▶] buttons

- The position can be moved diagonally by pressing buttons simultaneously.
- Move the 'Title Display' to any position.
- However, it cannot be shifted to the 'Warning Display Area'.
- The displayed characters will shift to the left, right or center automatically.

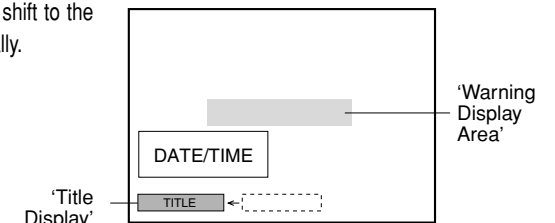
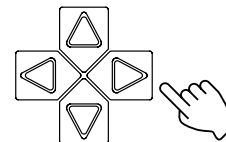

5. Press the [CANCEL] button

- This confirms the onscreen display position and returns the display to the normal screen.

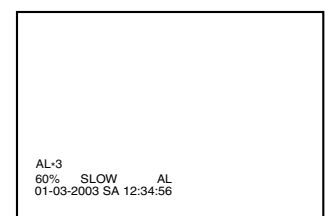
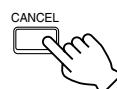

Menu Flow Chart

Menu Screen

MAIN MENU/OPERATION MENU	▶
ONSCREEN MODE	▶
FDP/BUZZER	▶
REC MODE	▶
CAMERA TITLE	▶
OPERATION/EXT REC	▶
MONITOR DISPLAY	▶
ALARM SENSOR MODE	▶
PROGRAM TIMER	▶
NETWORK	▶
DISK UTILITY/MAINTENANCE	▶

"CLOCK SET" Menu

CLOCK SET					
D	M	Y	H	M	
15	07	2003	12	28	
TIME ZONE: UTC					
<=:RETURN					

(☞ Page 16)

"CAMERA TITLE" Menu

CAMERA TITLE		
1.BLOCK	TITLE	(NONE)
2.CAMERA 1	TITLE	(NONE)
3.CAMERA 2	TITLE	(NONE)
4.CAMERA 3	TITLE	(NONE)
5.CAMERA 4	TITLE	(NONE)
<=:RETURN		

(☞ Page 25)

"ONSCREEN MODE" Menu

ONSCREEN MODE	
1.DATE/TIME	ON
2.PLAYBACK MODE	ON
3.TITLE	▶
4.ALARM/SENSOR COUNT	ON
5.DISK CAPACITY	ON
6.ALARM/SENSOR DETECT	ON
7.WARNING	ON
8.BACKGROUND COLOR	BLACK
9.DATE DISPLAY	D/M/Y

(☞ Page 23)

"OPERATION/EXT REC" Menu

OPERATION/EXT REC	
[OPERATION]	
1.RECOVERY REC	PRIOR STATE
2.REPEAT REC	OFF
3.LANGUAGE SELECTION	ENGLISH
4.WATER MARK	OFF
5.OPERATION LOCK	ALL
[EXT REC]	
1.EXT REC MODE	OFF
2.SERIES REC	OFF

(☞ Pages 25)

"FDP/BUZZER" Menu

FDP/BUZZER	
[FDP]	
1.ALARM/SENSOR MODE	ON
2.ALARM/SENSOR BLINK	ON
3.SEQUENTIAL MONITOR	ON
4.INPUT SIGNAL ERROR	ON
5.WARNING	ON
[BUZZER]	
1.HDD FULL	OFF
2.ALARM/SENSOR	OFF
3.WARNING	OFF

(☞ Pages 23, 24)

"MONITOR DISPLAY" Menu

MONITOR DISPLAY	
1.SINGLE PICTURE MODE	
2.SINGLE PICTURE MODE	
3.QUAD PICTURE MODE	
BLOCK 1	1SEC
BLOCK 2	1SEC
BLOCK 3	1SEC
BLOCK 4	1SEC
4.ALARM/SENSOR SWITCH	
5.SPLIT SCREEN BORDER COLOR BORDER 3	

(☞ Page 26)

"REC MODE" Menu

REC MODE	
1.BLOCK	
2.CAMERA 1	ON
3.CAMERA 2	OFF
4.CAMERA 3	OFF
5.CAMERA 4	OFF
6.FRAME RATE	25 IPS
7.REC QUALITY	H
8.AUDIO REC	ON
RECORDABLE HOUR	APPROX. 38H

(☞ Page 24)

"ALARM/SENSOR MODE" Menu

ALARM/SENSOR MODE	
1.BLOCK	
2.REC MODE	ALARM
3.FRAME RATE	25 IPS
4.QUALITY	H
5.DURATION	180SEC
6.AUDIO REC	ON
7.PRESENSOR REC	ON
8.PRESENSOR REC DURATION	10SEC
9.EXT INPUT OPERATING MODE	OFF
10.MOTION DETECT	OFF
11.MOTION DETECT SETTING	▶

(☞ Pages 27, 28)

“PROGRAM TIMER” Menu

```

PROGRAM TIMER
1.WEEKLY TIMER
2.DATE TIMER
3.AFTER RELEASE
CONTINUE
    
```

(☞ Pages 29, 30)

“WEEKLY TIMER” Menu

```

WEEKLY TIMER
START END CAM1-4 CAM5-8 CAM9-12 CAM13-16 EXEC
SUN *****
MON *****
TUE *****
WED *****
THU *****
FRI *****
SAT *****
DAY *****
<=:RETURN
[CANCEL]:CANCEL
    
```

(☞ Page 29)

“DATE TIMER” Menu

```

DATE TIMER
START END CAM1-4 CAM5-8 CAM9-12 CAM13-16 EXEC
1. --- -- 9. -- --
2. --- -- 10. -- --
3. --- -- 11. -- --
4. --- -- 12. -- --
5. --- -- 13. -- --
6. --- -- 14. -- --
7. --- -- 15. -- --
8. --- -- 16. -- --
<=:RETURN
[CANCEL]:CANCEL
    
```

(☞ Page 30)

“NETWORK” Menu

```

NETWORK
1.HOST NAME W716
2.METHOD STATIC
3.IP ADDRESS 192.168. 0. 10
4.NET MASK 255.255.255. 0
5.DEFAULT GATEWAY 192.168. 0.254
6.NAME SERVER 0. 0. 0. 0
MAC ADDRESS 00:80:88:40:b0:00
<=:RETURN
[CANCEL]:DELETE
    
```

(☞ Page 31)

“DEFRAG DATABASE” Menu

```

DEFRAG DATABASE
DEFRAG AUTO MODE DATE TIME SET
01 00 OFF
DEFRAG YES
SET [YES] FOR DEFRAG
<=:RETURN
[EXEC]:DEFRAG
    
```

(☞ Page 57)

“DISK UTILITY/MAINTENANCE” Menu

```

DISK UTILITY/MAINTENANCE
1.DISK UTILITY
2.MAINTENANCE
    
```

(☞ Page 31)

“DISK UTILITY” Menu

```

DISK UTILITY
1.AUTO SCAN DISK OFF
2.MANUAL SCAN DISK OFF
3.DEFRAG DATABASE
4.FORMAT
5.MIRRORING
    
```

(☞ Pages 31, 55)

“FORMAT” Menu

```

FORMAT
BUILT-IN HDD 1 : 76GB OK YES
BUILT-IN HDD 2 : 76GB OK YES
EXTERNAL HDD 1 :
EXTERNAL HDD 2 :
EXTERNAL HDD 3 :
EXTERNAL HDD 4 :
START FORMAT NO
ALL RECORDED HDD DATA IS DELETED!!
1.SET FORMATTING HDD TO [YES]
2.SET START FORMAT TO [YES]
    
```

(☞ Page 58)

“SINGLE PICTURE MODE” Menu

```

SINGLE PICTURE MODE
1.CAMERA 1 1SEC 9.CAMERA 9 1SEC
2.CAMERA 2 1SEC 10.CAMERA 10 1SEC
3.CAMERA 3 1SEC 11.CAMERA 11 1SEC
4.CAMERA 4 1SEC 12.CAMERA 12 1SEC
5.CAMERA 5 1SEC 13.CAMERA 13 1SEC
6.CAMERA 6 1SEC 14.CAMERA 14 1SEC
7.CAMERA 7 1SEC 15.CAMERA 15 1SEC
8.CAMERA 8 1SEC 16.CAMERA 16 1SEC
<=:RETURN
    
```

(☞ Page 26)

“MAINTENANCE” Menu

```

MAINTENANCE
1.TOTAL TIME 22H
2.POWER OUTAGE TIME LIST
PL-1 10/07/2003 TH 10:47
PL-***** **/**/**** ** **
PL-***** **/**/**** ** **
PL-***** **/**/**** ** **
[CANCEL]:LIST CLEAR
    
```

(☞ Pages 31, 60)

“MIRRORING” Menu

```

MIRRORING
BUILT-IN HDD 1 : 76GB OK
BUILT-IN HDD 2 : 76GB OK
MIRRORING SETTING NO
ALL HDD DATA WILL BE DELETED!!
NO MIRRORING SETTING
SET [YES] FOR MIRRORING SETTING
[EXEC]:START MIRROR
    
```

(☞ Pages 59, 60)

“DETAIL SETTING” Menu

```

DETAIL SETTING
1.DETECTING SENSITIVITY 7
2.TERMINATION SENSITIVITY +3
3.OBJECT SIZE LEVEL 2
    
```

(☞ Page 28)

“MOTION DETECT SETTING” Menu

```

MOTION DETECT SETTING
1.MOTION DETECT 1
2.CAMERA 1 SCENE MANUAL
AREA SETTING
3.CAMERA 2 SCENE MANUAL
AREA SETTING
4.CAMERA 3 SCENE MANUAL
AREA SETTING
5.CAMERA 4 SCENE MANUAL
AREA SETTING
    
```

(☞ Page 28)

“CAMERA AREA SETTING” Menu

```

CAMERA2 AREA SETTING
[CANCEL]:CANCEL AREA [EXEC]:SET AREA
[CANCEL]HOLD:DELETE ALL
[EXEC]HOLD:SET ALL
[SEARCH]HOLD:CHECK MODE
[SEARCH]:CHECK MODE CLEAR
    
```

(☞ Pages 68, 69)

Menus (continued)

Changing Menu Settings

Changing Initial Settings

Change the VR-716 preset values (Factory settings) during purchase according to its use.

Connect the monitor for which the menu screen is to be displayed to the [VIDEO OUT] terminal. (☞ Page 33)

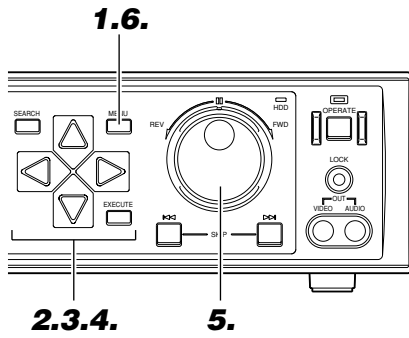

1. Press the [MENU] button

- This displays the “MAIN MENU/OPERATION MENU” screen on the monitor.

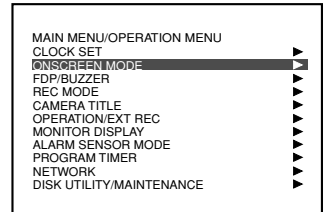
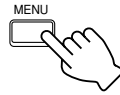

2. Select menu item using [▲ / ▼]

- Move the cursor to select.



3. Press the [▶] button

- The settings are displayed.

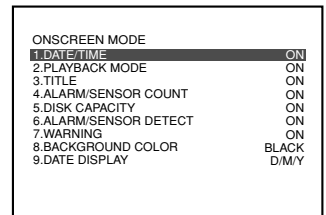
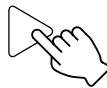

Notes

- Changes can be made to items in the following menus when in the Recording mode:
 - “ONSCREEN MODE” (excluding DATE DISPLAY) (☞ Page 23)
 - “FDP” (☞ Page 23)
 - “BUZZER” (☞ Page 24)
 - “MONITOR DISPLAY” (☞ Page 26)
 - “SEARCH MENU”
- Menu operation is disabled when in the Timer mode.
- Values that have been altered will be written into the memory when exiting the menu screen. Do not continue using with the altered menu screens left open.

4. Select menu item using [▲ / ▼]

- Move the cursor to select.

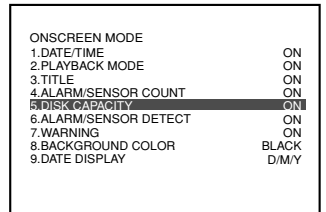

5. Turn the jog dial to select a value

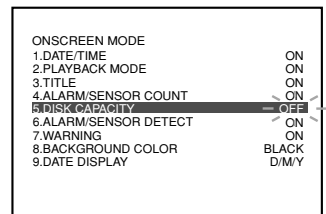
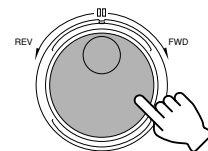

6. Press [MENU] to end setting

- The display returns to the normal screen.

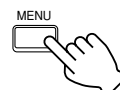

“ONSCREEN MODE” Menu

[●] are factory settings.

Item	Settings	Description
“DATE/TIME”	● “ON” “OFF”	For setting the Day/Month/Year and clock’s onscreen display. “ON” : Date/time displayed. “OFF” : Date/time not displayed.
“PLAYBACK MODE”	● “ON” “OFF”	For setting the onscreen display of the Playback mode. “ON” : Playback mode displayed. “OFF” : Playback mode not displayed.
“TITLE”	● “ON” “OFF”	For setting the onscreen display of camera channel titles. “ON” : Title displayed. “OFF” : Title not displayed.
“ALARM/SENSOR COUNT”	● “ON” “OFF”	For setting the onscreen display of Alarm/Sensor Nos. “ON” : Alarm/Sensor No. displayed. “OFF” : Alarm/Sensor No. not displayed.
“DISK CAPACITY”	● “ON” “OFF”	For setting the onscreen display of the remaining hard disk space. “ON” : Remaining disk space displayed. (Display is not shown when in the Repeat Record mode.) “OFF” : Remaining disk space not displayed.
“ALARM/SENSOR DETECT”	● “ON” “OFF”	For setting whether to display the [AL] mark onscreen during alarm/sensor recording. “ON” : [AL] mark displayed. “OFF” : [AL] mark not displayed.
“WARNING”	● “ON” “OFF”	For setting whether to display warning onscreen during error. “ON” : Warning displayed. “OFF” : Warning not displayed.
“BACKGROUND COLOR”	● “BLACK” “CLEAR”	For setting the background of the settings menu screen. “BLACK” : Displays background in black. “CLEAR” : Displays live camera images or playback images.
“DATE DISPLAY”	● “D/M/Y” “Y/M/D” “M/D/Y”	For changing the order of date display.

“FDP” Menu

[●] are factory settings.

Item	Settings	Description
“ALARM/SENSOR MODE”	● “ON” “OFF”	For setting whether to light up the [AL] (alarm) Indicator ⑥ (☞ Page 12) on the front display during alarm/sensor recording. “ON” : Indicator lights up. “OFF” : Indicator does not light up. ☞ Page 12 ‘Names and Functions (Front Display)’
“ALARM/SENSOR BLINK”	● “ON” “OFF”	For setting whether to blink the [AL] (alarm) Indicator ⑥ (☞ Page 12) on the front display upon completion of alarm/sensor recording. “ON” : Indicator blinks. “OFF” : Indicator does not blink. ☞ Page 12 ‘Names and Functions (Front Display)’
“SEQUENTIAL MONITOR”	● “ON” “OFF”	For setting whether to turn on the LED for the camera selection button ⑨ (☞ Page 7) on the front panel. “ON” : LED of the camera selection button that corresponds to the Camera No. on the monitor screen turns on. “OFF” : LED of the camera selection button that corresponds to the Camera No. on the monitor screen does not turn on. However, LED lights up when displaying in 16 split pictures.
“INPUT SIGNAL ERROR”	● “ON” “OFF”	For setting the mode of illumination of the camera selection button LED ⑨ (☞ Page 7) on the front panel when signal error occurs at the camera. “ON” : Blinks when “ON” is selected for the camera in the “REC MODE” Menu but there are no camera signals, or when SINGLE PICTURE is selected using the camera selection button and “OFF” is selected for the specified camera in the “REC MODE” Menu. “OFF” : LED does not blink. ※ The setting of “INPUT SIGNAL ERROR” on the front display is different from what is displayed onscreen.
“WARNING”	● “ON” “OFF”	For setting whether to display warning on the front display during error. “ON” : Warning displayed. “OFF” : Warning not displayed. ☞ Page 105 ‘Problems Related to Error Code and Onscreen Display’

Menus (continued)

“BUZZER” Menu

[●] are factory settings.

Item	Settings	Description
“HDD FULL”	“ON” ● “OFF”	For setting whether to sound the buzzer when the hard disk has no more space during recording. “ON” : The buzzer sounds. “OFF” : The buzzer does not sound.
“ALARM/SENSOR”	“ON” ● “OFF”	For setting whether to sound buzzer during alarm/sensor recording. “ON” : The buzzer sounds. “OFF” : The buzzer does not sound.
“WARNING”	“ON” ● “OFF”	For setting whether to sound buzzer when error occurs. “ON” : The buzzer sounds. “OFF” : The buzzer does not sound. ⓘ Page 105 ‘Problems Related to Error Code and Onscreen Display’

“REC MODE” Menu

[●] are factory settings. (Setting is disabled when in the Recording mode.)

Item	Settings	Description
“BLOCK”	● 1 2 3 4	For selecting the camera channel block for which “REC MODE” setting is to be performed. 1 : Sets to Camera Channels 1 - 4. 2 : Sets to Camera Channels 5 - 8. 3 : Sets to Camera Channels 9 - 12. 4 : Sets to Camera Channels 13 - 16.
“CAMERA 1” ~ “CAMERA 4” (When “BLOCK 1” is selected)	● “ON” “OFF”	For selecting the camera to perform recording. “ON” : Recording enabled. “OFF” : Recording disabled. <div style="border: 1px solid black; border-radius: 10px; padding: 5px; margin-top: 10px;"> Note <ul style="list-style-type: none"> Menu items vary according to the block selected. “BLOCK 2”: “CAMERA 5” ~ “CAMERA 8”, “BLOCK 3”: “CAMERA 9” ~ “CAMERA 12”, “BLOCK 4”: “CAMERA 13” ~ “CAMERA 16”. </div>
“FRAME RATE”	● “25 IPS” “12.5 IPS” “8.3 IPS” “4.2 IPS” “2.5 IPS” “1.7 IPS” “1 IPS” “1/2 IPS” “1/6 IPS” “1/12 IPS”	For setting the no. of frames to be recorded. <div style="border: 1px solid black; border-radius: 10px; padding: 5px; margin-top: 10px;"> Note <ul style="list-style-type: none"> “AUDIO REC” switches automatically to “OFF” when “1/6 IPS” (1 image per 6 seconds) or “1/12 IPS” (1 image per 12 seconds) is selected for “FRAME RATE”. </div>
“REC QUALITY”	“H” ● “N” “B” “L”	For setting the picture quality of the image to be recorded. “H” : HIGH (High picture quality) “N” : NORMAL (Normal picture quality) “B” : BASIC (Basic picture quality) “L” : LONG (Long-play quality)
“AUDIO REC”	● “ON” “OFF”	For setting whether to record audio signals. “ON” : Audio signals recorded. “OFF” : Audio signals not recorded. <div style="border: 1px solid black; border-radius: 10px; padding: 5px; margin-top: 10px;"> Note <ul style="list-style-type: none"> Switches automatically to “OFF” when “1/6 IPS” (1 image per 6 seconds) or “1/12 IPS” (1 image per 12 seconds) is selected for “FRAME RATE” in the menu. </div>
“RECORDABLE HOUR”	-----	Displays the remaining amount of time for which recording is possible at the hard disk. <div style="border: 1px solid black; border-radius: 10px; padding: 5px; margin-top: 10px;"> Note <ul style="list-style-type: none"> Length of recordable time varies with the settings of the “FRAME RATE”, “REC QUALITY” and “AUDIO REC” items. ⓘ Page 115 ‘Recording Duration’ </div>

“CAMERA TITLE” Menu

[●] are factory settings. (Setting is disabled when in the Recording mode.)

Item	Settings	Description
“CAMERA 1” ~ “CAMERA 16”	*****	Camera Channels 1 - 16 can be named separately. ☞ Page 72 ‘Setting a Title for Each Camera Channel Screen’

“OPERATION” Menu

[●] are factory settings. (Setting is disabled when in the Recording mode.)

Item	Settings	Description																																																																			
“RECOVERY REC”	● “OFF” “PRIOR STATE” “NORMAL REC”	For setting whether to perform Recovery Recording. “OFF” : Switches to the Stop mode upon restoration from power failure. (Switches to the Timer mode upon restoration if the Program Timer is set.) “PRIOR STATE” : Re-starts recording upon restoration from power failure, only when power failure occurs during recording. “NORMAL REC” : Re-starts recording upon restoration from power failure. ☞ Page 71 ‘Continuing with Recording Upon Recovery from Power Failure’																																																																			
“REPEAT REC”	● “OFF” “ALARM STOP” “ALARM LOCK” “ALL”	For setting whether to perform Repeat Recording. “OFF” : Repeat recording disabled. “ALARM STOP” : Repeat Recording mode is disabled if alarm recording has been executed. “ALARM LOCK” : Alarm recording is basically protected from overwriting during repeat recording, but images other than alarm recording may remain if the hard disk space is filled up mostly by Alarm recording. “ALL” : When there is insufficient hard disk space, previous recordings are overwritten, starting from the oldest recording. ☞ Page 112 ‘Repeat Record’																																																																			
“LANGUAGE SELECTION”	● “ENGLISH” “GERMAN” “FRENCH” “ITALIAN” “SPANISH”	For selecting a language displayed in the menu.																																																																			
“WATER MARK”	● “ON” “OFF”	For setting whether to embed water mark in the recorded images. “ON” : Records images with embedded water mark. “OFF” : Records images without embedded water mark. <div style="border: 1px solid black; padding: 5px;"> <p>Notes</p> <ul style="list-style-type: none"> When in the 1 input per block mode, water mark will not be recorded depending on the setting. Refer to the following table. (○ : recordable, × : not recordable) <table border="1" style="margin-left: auto; margin-right: auto;"> <thead> <tr> <th colspan="2" rowspan="2"></th> <th colspan="10">FRAME RATE (IPS)</th> </tr> <tr> <th>25</th> <th>12.5</th> <th>8.3</th> <th>4.2</th> <th>2.5</th> <th>1.7</th> <th>1</th> <th>1/2</th> <th>1/6</th> <th>1/12</th> </tr> </thead> <tbody> <tr> <td rowspan="4" style="writing-mode: vertical-rl; transform: rotate(180deg);">REC QUALITY</td> <td>H</td> <td>○</td> <td>○</td> <td>○</td> <td>○</td> <td>○</td> <td>○</td> <td>○</td> <td>○</td> <td>○</td> <td>○</td> </tr> <tr> <td>N</td> <td>○</td> <td>○</td> <td>○</td> <td>○</td> <td>○</td> <td>○</td> <td>×</td> <td>×</td> <td>×</td> <td>×</td> </tr> <tr> <td>B</td> <td>×</td> <td>×</td> <td>×</td> <td>×</td> <td>×</td> <td>×</td> <td>×</td> <td>×</td> <td>×</td> <td>×</td> </tr> <tr> <td>L</td> <td>×</td> <td>×</td> <td>×</td> <td>×</td> <td>×</td> <td>×</td> <td>×</td> <td>×</td> <td>×</td> <td>×</td> </tr> </tbody> </table> <ul style="list-style-type: none"> For details on water mark detection, please refer to the application software [VR-716 Player] Manual (CD-ROM) provided. </div>			FRAME RATE (IPS)										25	12.5	8.3	4.2	2.5	1.7	1	1/2	1/6	1/12	REC QUALITY	H	○	○	○	○	○	○	○	○	○	○	N	○	○	○	○	○	○	×	×	×	×	B	×	×	×	×	×	×	×	×	×	×	L	×	×	×	×	×	×	×	×	×	×
		FRAME RATE (IPS)																																																																			
		25	12.5	8.3	4.2	2.5	1.7	1	1/2	1/6	1/12																																																										
REC QUALITY	H	○	○	○	○	○	○	○	○	○	○																																																										
	N	○	○	○	○	○	○	×	×	×	×																																																										
	B	×	×	×	×	×	×	×	×	×	×																																																										
	L	×	×	×	×	×	×	×	×	×	×																																																										
“OPERATION LOCK”	● “ALL” “STOP REC”	For setting the lock operation when the operation lock is ON. “ALL” : Disables all operations. “STOP REC” : Disables operation to start or stop recording.																																																																			

“EXT REC” Menu

[●] are factory settings. (Setting is disabled when in the Recording mode.)

Item	Settings	Description
“EXT REC MODE”	● “OFF” “TRIGGER” “MANUAL”	For setting whether to start automatic recording when external signals are received at the [EXT REC IN] of the signal input/output terminal. “OFF” : Automatic recording not executed. “TRIGGER” : Starts recording upon receiving external signals. “MANUAL” : Continues recording when external signals are input. ☞ Page 61 ‘Activation of Recording Via External Signals’
“SERIES REC”	● “ON” “OFF”	For setting whether to execute SERIES recording based on signals received at the [SERIES REC IN/OUT] terminal. “ON” : Executes SERIES recording based on [SERIES REC IN/OUT] signals. “OFF” : Does not execute SERIES recording based on [SERIES REC IN/OUT] signals. ☞ Page 61 ‘Series Recording Using 2 or More VR-716 Recorders’

Menus (continued)

“MONITOR DISPLAY” Menu

[●] are factory settings.

Item	Settings	Description
“EE OUT1 - 4/ -16”	<ul style="list-style-type: none"> ● “1-4” “1-16” 	For setting the screen during output of camera images in VR-716 to the [EE OUT 1-4/-16] terminal. “1-4” : Images displayed in quad picture. “1-16” : Images displayed in 16 split pictures. ☞ Page 32 ‘When Connecting the Monitor to the [EE OUT] terminal’
“SINGLE PICTURE MODE”		
“SINGLE PICTURE MODE” “CAMERA1” ~ “CAMERA16”	<ul style="list-style-type: none"> ● “OFF” ● “1 SEC” “2 SEC” “3 SEC” “4 SEC” “5 SEC” “10 SEC” 	For setting the time interval at which display at VR-716 is switched from the live image of one camera to another. “OFF” : Automatic switching of camera channels turned off. “1 SEC” : Switches camera channel at an interval of 1 second. “2 SEC” : Switches camera channel at an interval of 2 seconds. “3 SEC” : Switches camera channel at an interval of 3 seconds. “4 SEC” : Switches camera channel at an interval of 4 seconds. “5 SEC” : Switches camera channel at an interval of 5 seconds. “10 SEC” : Switches camera channel at an interval of 10 seconds. ☞ Page 34 ‘Setting Time Interval for Switching Displays in the Single Picture Mode’
“QUAD PICTURE MODE” “BLOCK 1” ~ “BLOCK 4”	<ul style="list-style-type: none"> ● “OFF” ● “1 SEC” “2 SEC” “3 SEC” “4 SEC” “5 SEC” “10 SEC” 	For setting the time interval at which display is switched from one camera channel block to another when in quad picture. “OFF” : Automatic switching of camera channels turned off. “1 SEC” : Switches camera channel at an interval of 1 second. “2 SEC” : Switches camera channel at an interval of 2 seconds. “3 SEC” : Switches camera channel at an interval of 3 seconds. “4 SEC” : Switches camera channel at an interval of 4 seconds. “5 SEC” : Switches camera channel at an interval of 5 seconds. “10 SEC” : Switches camera channel at an interval of 10 seconds. ☞ Page 35 ‘Setting Time Interval for Switching Displays in the Quad Picture Mode’
“ALARM/SENSOR SWITCH”	<ul style="list-style-type: none"> ● “OFF” “SEQUENTIAL” “FIX” 	For setting the switching mode of the monitor screen when alarm/sensor signals are received. “OFF” : Sends output to monitor according to the Camera Selection button settings. “SEQUENTIAL” : Sends only output of cameras for which alarm has been triggered to the monitor in sequence. (Switching of display is fixed at an interval of 1 second.) “FIX” : Sends only output of the camera for which its alarm has last been triggered to the monitor. <div style="border: 1px solid black; border-radius: 10px; padding: 5px; margin-top: 10px;"> <p style="text-align: center; margin: 0;">Notes</p> <ul style="list-style-type: none"> Screen display of monitor can be switched using the Camera Selection buttons even when “SEQUENTIAL” or “FIX” are selected. When multiple alarms are simultaneously detected, image of cameras for which alarm has been triggered will be output to the monitor alternately even when “FIX” is selected. </div>
“SPLIT SCREEN BORDER COLOR”	<ul style="list-style-type: none"> ● “OFF” “BORDER 1” “BORDER 2” ● “BORDER 3” 	For setting the brightness of the border line of split screen. “BORDER 1” : Dark grey “BORDER 2” : Grey “BORDER 3” : Bright grey

“ALARM/SENSOR MODE” Menu

This menu is used for specifying settings related to alarm or sensor recording.

Alarm/sensor inputs are either received via the [ALARM IN] terminal at the rear panel of VR-716 or via Motion Detect.

[●] are factory settings. (Setting is disabled when in the Recording mode.)

Item	Settings	Description
“BLOCK”	<ul style="list-style-type: none"> ● 1 2 3 4 	For selecting the camera channel block for which alarm or sensor recording settings are to be specified. 1 : Sets to Camera Channels 1 - 4. 2 : Sets to Camera Channels 5 - 8. 3 : Sets to Camera Channels 9 - 12. 4 : Sets to Camera Channels 13 - 16.
“REC MODE”	<ul style="list-style-type: none"> ● “ALARM” “SENSOR” “ALARM/SENSOR” 	For specifying settings related to alarm and sensor recording. “ALARM” : Starts alarm recording only when VR-716 is in the normal recording mode. “SENSOR” : Starts sensor recording only when VR-716 is in the Stop mode. “ALARM/SENSOR” : Starts alarm recording when in the normal recording mode and sensor recording when in the Stop mode. ⓘ Page 66 ‘Activation of Recording Via External Alarm/Sensor Signals’
“FRAME RATE”	<ul style="list-style-type: none"> ● “25 IPS” “12.5 IPS” “8.3 IPS” “4.2 IPS” 	For setting the frame rate during alarm recording. Value is set according to the no. of images to record in 1 second.
“QUALITY”	<ul style="list-style-type: none"> ● “H” “N” “B” “L” 	For setting the picture quality during alarm recording. “H” : HIGH (High picture quality) “N” : NORMAL (Normal picture quality) “B” : BASIC (Basic picture quality) “L” : LONG (Long-play quality)
“DURATION”	<ul style="list-style-type: none"> “10 SEC” “15 SEC” “30 SEC” “60 SEC” “120 SEC” ● “180 SEC” “MANUAL” 	For setting the duration of alarm or sensor recording. “10 SEC” ~ “180 SEC” : Duration of alarm/sensor recording. “MANUAL” : Continues alarm/sensor recording when alarm signals are input. (Maximum: 20 minutes) In the case of alarm or sensor recording via Motion Detect, recording lasts for a duration of 10 seconds upon the last sensor detection.
“AUDIO REC”	<ul style="list-style-type: none"> ● “ON” “OFF” 	For setting whether to record audio signals. “ON” : Audio signals recorded. “OFF” : Audio signals not recorded.
“PRESENSOR REC”	<ul style="list-style-type: none"> “ON” ● “OFF” 	For setting whether to activate presensor recording. Select “ON” to activate presensor recording. ⓘ Page 113 ‘Presensor Recording’
“PRESENSOR REC DURATION”	<ul style="list-style-type: none"> ● “10 SEC” “20 SEC” “30 SEC” 	For setting the duration of presensor recording. “10 SEC” : Activates presensor recording over an interval of 10 ~ 20 seconds. “20 SEC” : Activates presensor recording over an interval of 20 ~ 30 seconds. “30 SEC” : Activates presensor recording over an interval of 30 ~ 60 seconds. ⓘ Page 113 ‘Presensor Recording’

Menus (continued)

“ALARM/SENSOR MODE” Menu (continued)

[●] are factory settings. (Setting is disabled when in the Recording mode.)

Item	Settings	Description
“EXT INPUT OPERATING MODE”	<ul style="list-style-type: none"> ● “OFF” “ON” “NORMAL” “TIMER” 	<p>For setting alarm or sensor recording actions for the signal input/output terminal [ALARM IN] of VR-716.</p> <p>“OFF” : Alarm/sensor recording not activated. “ON” : Alarm/sensor recording activated. “NORMAL” : Alarm/sensor recording activated except when in the Timer Recording or Timer Standby mode. “TIMER” : Alarm/sensor recording activated when in the Timer Recording or Timer Standby mode.</p> <p>☞ Page 66 ‘Activation of Recording Via External Alarm/Sensor Signals’</p>
“MOTION DETECT”	<ul style="list-style-type: none"> ● “OFF” “ON” “NORMAL” “TIMER” 	<p>For setting alarm or sensor recording using Motion Detect.</p> <p>“OFF” : Motion Detect not activated. “ON” : Motion Detect activated. “NORMAL” : Motion Detect activated except when the Program Timer is in the Standby mode. “TIMER” : Motion Detect activated when the Program Timer is in the Standby mode.</p> <p>☞ Page 68 ‘Using the Motion Detect Feature’</p>
“MOTION DETECT SETTING”		
“SCENE”	<ul style="list-style-type: none"> ● “STANDARD” “MANUAL” “DOORWAY H” “DOORWAY L” “PASSAGE H” “PASSAGE L” “REGISTER H” “REGISTER L” “ATM H” “ATM L” “LOBBY H” “LOBBY L” “GATE H” “GATE L” “PARKING LOT H” “PARKING LOT L” “LOW LUX H” “LOW LUX L” “ELEVATOR” “COUNTER” 	<p>For setting the sensitivity of the Motion Detect feature. Sensitivity is set upon selecting an item in “SCENE”.</p> <p>“DOORWAY” : To detect the opening and closing of the door of building and shop, or people going in and out. “PASSAGE” : To detect the movement of people on the passageway in the school, corporation or shop. “REGISTER” : To detect the movement of people operating the cash register in the shop/change machine in amusement center, or the change in the waiting queue. “ATM” : To detect the change in users at the entrance of ATM terminals of bank or post office. “LOBBY” : To detect the movement of people in the wide lobby. “GATE” : To detect the opening and closing of the door at a dim entrance or employee use entrance, or people going in and out. “PARKING LOT” : To detect the cars going in and out of the entrance of car parks outside a house. “LOW LUX” : To detect the movement of people outside a dark house. “ELEVATOR” : To detect the opening and closing of an elevator door, or people going in and out. “COUNTER” : To detect the visitors going in and out at the reception of hotel, corporation or shop.</p> <p>※ “SCENE” setting is a reference. Please try other settings if the sensitivity does not suit your requirement.</p> <p>The following details can be specified when “MANUAL” is selected: “DETAIL SETTING” for each camera “DETECTING SENSITIVITY” 1 ~ 15 (Factory setting: 7) “TERMINATION SENSITIVITY” +0 ~ 14 (Factory setting: +3) “OBJECT SIZE LEVEL” 1 ~ 10 (Factory setting: 2) “DETECTING SENSITIVITY” : Level for detection. The higher the value, the higher the sensitivity. “TERMINATION SENSITIVITY” : An offset level for detection sensitivity. The higher the value, the lesser the interruption to the alarm detection.</p> <p>※ Valid when the sum of “DETECTING SENSITIVITY” and “TERMINATION SENSITIVITY” is 15 or less. If the value is set to more than 15, it will be automatically adjusted to the maximum value when exiting setting. “OBJECT SIZE LEVEL” : Level for the size of the object to be detected. The higher the value the lower the sensitivity to detect the motion of small objects.</p> <p>☞ Page 68 ‘Using the Motion Detect Feature’</p>
“AREA SETTING”		<p>For setting the area from which motion is to be detected using the Motion Detect feature.</p> <p>☞ Page 68 ‘Using the Motion Detect Feature’</p>

“PROGRAM TIMER” Menu

Setting is disabled when in the Recording mode.

Item	Settings	Description
“WEEKLY TIMER”		Opens the “WEEKLY TIMER” screen in the “PROGRAM TIMER” for setting. ☞ Page 50 ‘Record Programming Using the Program Timer (Weekly Timer)’
“START”/“END” DAY	“SUN”, “MON”, “TUE”, “WED”, “THU”, “FRI”, “SAT”, “DAY”	Starts/Ends recording at a specific time every week/day. For setting the day of the week for which recording starts/ends (or to start/end recording on a daily basis). Starting/Ending time can be set using the “START”/“END” TIME (HOUR) and “START”/“END” TIME (MINUTE) items described below. “SUN” ~ “SAT” : For setting the day of the week for which recording starts/ends. “DAY” : Starts recording at a specific time everyday. In this case, days of the week for which recording is to be activated can also be specified.
“START”/“END” TIME (HOUR)	00 ~ 23	For setting the starting/ending time (in units of hours) of the timer.
“START”/“END” TIME (MINUTE)	00 ~ 59	For setting the starting/ending time (in units of minutes) of the timer.
“FRAME RATE”	25 12.5 8.3 4.2 2.5 1.7 1 1/2 1/6 1/12	For setting the no. of frames to be recorded. 25 : “25 IPS” 12.5 : “12.5 IPS” 8.3 : “8.3 IPS” 4.2 : “4.2 IPS” 2.5 : “2.5 IPS” 1.7 : “1.7 IPS” 1 : “1 IPS” 1/2 : “1/2 IPS” 1/6 : “1/6 IPS” 1/12 : “1/12 IPS” Note • “AUDIO REC” switches automatically to “-” when “1/6 IPS” (1 image per 6 seconds) or “1/12 IPS” (1 image per 12 seconds) is selected for “FRAME RATE”.
“REC QUALITY”	“H” “N” “B” “L”	For setting the picture quality of the image to be recorded. “H” : HIGH (High picture quality) “N” : NORMAL (Normal picture quality) “B” : BASIC (Basic picture quality) “L” : LONG (Long-play quality)
“AUDIO REC”	“A” -	For setting whether to record audio signals. “A” : Audio signals recorded. - : Audio signals not recorded. Note • Switches automatically to “-” when “1/6 IPS” (1 image per 6 seconds) or “1/12 IPS” (1 image per 12 seconds) is selected for “FRAME RATE” in the menu.
“EXEC”	“OFF” “ON” “WLY”	For turning on/off the timer. “OFF” : Timer not activated. “ON” : Turns “OFF” after recording has been executed once on a specific day/time. (Remains in the “ON” mode if “DAY” has been selected as the starting day.) “WLY” : Timer activates during the time range set on a weekly basis. Disabled when “START”/“END” DAY is set as “DAY”.

Menus (continued)

“PROGRAM TIMER” Menu (continued)

[●] are factory settings.

Item	Settings	Description		
“DATE TIMER”		For executing the recording of a program on a specific date. Opens the “DATE TIMER” screen in the “PROGRAM TIMER” Menu for setting. ☞ Page 52 ‘Record Programming Using the Program Timer (Date Timer)’		
“START”/“END” TIME (HOUR)	00 ~ 23	For setting the starting/ending time (in units of hours) of the timer.		
“START”/“END” TIME (MINUTE)	00 ~ 59	For setting the starting/ending time (in units of minutes) of the timer.		
“FRAME RATE”	25 12.5 8.3 4.2 2.5 1.7 1 1/2 1/6 1/12	For setting the no. of frames to be recorded. 25 : “25 IPS” 1.7 : “1.7 IPS” 12.5 : “12.5 IPS” 1 : “1 IPS” 8.3 : “8.3 IPS” 1/2 : “1/2 IPS” 4.2 : “4.2 IPS” 1/6 : “1/6 IPS” 2.5 : “2.5 IPS” 1/12 : “1/12 IPS” Note • “AUDIO REC” switches automatically to “-” when “1/6 IPS” (1 image per 6 seconds) or “1/12 IPS” (1 image per 12 seconds) is selected for “FRAME RATE”.		
“REC QUALITY”	“H” “N” “B” “L”	For setting the picture quality of the image to be recorded. “H” : HIGH (High picture quality) “N” : NORMAL (Normal picture quality) “B” : BASIC (Basic picture quality) “L” : LONG (Long-play quality)		
“AUDIO REC”	“A” -	For setting whether to record audio signals. “A” : Audio signals recorded. - : Audio signals not recorded. Note • Switches automatically to “-” when “1/6 IPS” (1 image per 6 seconds) or “1/12 IPS” (1 image per 12 seconds) is selected for “FRAME RATE” item in the menu.		
“EXEC”	● “ON” “OFF”	For turning on/off the programmed timer. “ON” : Starts recording on the specified date every year. “OFF” : Timer not activated.		
START DATE “M” (MONTH)	1 ~ 12	For setting the date (in the Month unit) at which timer recording is executed.		
START DATE “D” (DAY)	1 ~ 31	For setting the date (in the Day unit) at which timer recording is executed. Note • When execution date is set as February 28 and ending date as the following day, the ending date of the program will be February 29 on leaps years and March 1 otherwise.		
“AFTER RELEASE”	“CONTINUE” “NORMAL REC” ● “STOP”	For setting the action when the timer is released upon pressing the [TIMER] button during timer recording or timer standby, or when all the timer recordings have ended and timers are released. “CONTINUE” : When the timer is released during timer recording, it continues in the recording mode until the [STOP] button is pressed. When the timer is released during timer standby or when all the timer recordings have ended, it remains in the stop mode. “NORMAL REC” : Stops recording using the Program Timer and switches to recording in the mode as set in the “REC MODE” Menu (☞ Page 24). “STOP” : Stops recording using the Program Timer instantly.		
Action when timer is released according to the respective settings of “AFTER RELEASE”				
		Status when timer is released		
		Timer Recording Timer Standby All programs ended		
Settings	CONTINUE	Continues in the timer recording mode	STOP	STOP
	NORMAL REC	Starts normal recording	Starts normal recording	Starts normal recording
	STOP	STOP	STOP	STOP

“NETWORK” Menu

[●] are factory settings. (Setting is disabled when in the Recording mode.)

Item	Settings	Description
“HOST NAME”	vr716	For setting the display name of VR-716 when it is connected to the network. ☞ Page 96 ‘Changing Network Settings of VR-716 from PC’
“METHOD”	<ul style="list-style-type: none"> ● “STATIC” “DHCP” “OFF” 	For selecting the method of setting the IP address. “STATIC” : Select this when connecting to the network without using the DHCP server. When “STATIC” is selected, the “IP ADDRESS”, “NET MASK” and “DEFAULT GATEWAY” items will need to be specified as well. “DHCP” : Select this when connecting to the network using the DHCP server. “IP ADDRESS”, “NET MASK” and “DEFAULT GATEWAY” will be automatically assigned by the DHCP server. When “DHCP” is selected, the IP address will be masked. It will appear when displaying the “NETWORK” menu again after exiting it. “OFF” : Not connected to the network. ☞ Page 96 ‘Changing Network Settings of VR-716 from PC’
“IP ADDRESS”	192.168.0.10	For setting the “IP ADDRESS”, “NET MASK”, “DEFAULT GATEWAY” and “NAME SERVER”. Setting of these items will be required when “STATIC” is selected in the “METHOD” item of the “NETWORK” Menu. Ensure that there are no duplicate IP addresses in the network. ☞ Page 96 ‘Changing Network Settings of VR-716 from PC’ <div style="border: 1px solid black; border-radius: 10px; padding: 5px; margin-top: 10px;"> <p style="text-align: center; margin: 0;">Note</p> <ul style="list-style-type: none"> Setting will be disabled when “DHCP” address is selected in the “METHOD” item of the “NETWORK” Menu. (In this case, only the name server can be altered.) </div>
“NET MASK”	255.255.255.0	
“DEFAULT GATEWAY”	192.168.0.254	
“NAME SERVER”	***.***.***.***	
“MAC ADDRESS”		Unique physical address of the product. This address cannot be altered.

※ A “IP ADDRESS SETTING IN PROGRESS...” message will be displayed on the monitor screen upon changing the network settings. All operations are disabled when this is shown.

“DISK UTILITY/MAINTENANCE” Menu

[●] are factory settings. (Setting is disabled when in the Recording mode.)

Item	Settings	Description
“DISK UTILITY”		
“AUTO SCAN DISK”	“ON” ● “OFF”	For setting whether to scan disk upon turning “ON” the power of VR-716. “ON” : Starts to scan disk when the power is ON. “OFF” : Does not scan disk. ☞ Page 55 ‘Scanning Hard Disk Data (“AUTO SCAN DISK”)’
“MANUAL SCAN DISK”	“ON” ● “OFF”	Scan Disk starts upon setting to “ON” and performing procedures according to the onscreen message. ☞ Page 56 ‘Scanning Hard Disk Data (“MANUAL SCAN DISK”)’
“DEFRAG AUTO MODE”	“DATE” “TIME” “SET” 01 00 “ON” ● “OFF”	For performing defrag. Do so by following procedures according to the onscreen message. ☞ Page 57 ‘Defrag’
“DEFRAG DATABASE”	“YES” ● “NO”	
“FORMAT”	“YES” ● “NO”	For formatting the hard disk. Do so by following procedures according to the onscreen message. ☞ Page 58 ‘Initializing the Hard Disk (“FORMAT”)’
“MIRRORING”	“YES” ● “NO”	Specifies the mirroring settings. Do so by following procedures according to the onscreen message. ☞ Page 59 ‘Hard Disk Mirroring’
“MAINTENANCE”		
“TOTAL TIME”		Displays the total operating time.
“POWER OUTAGE TIME LIST”		Displays the time at which power failure is detected. Use the [CANCEL] button to clear the list.

Routine Uses

Viewing Live Camera Images

When connecting the monitor to the [EE OUT] terminal

Only live images currently displayed can be viewed on the monitor that is connected to the [EE OUT] terminal. Playback of recorded images and display of menu screens are not possible.

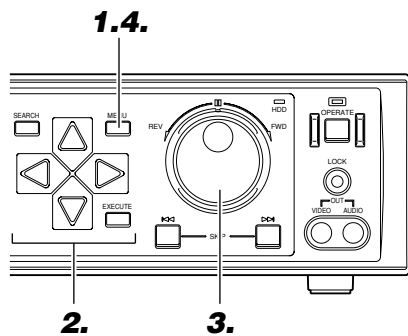
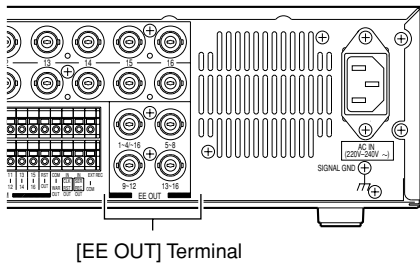

The following screen will be displayed on the monitor when it is connected to the [EE OUT] terminal:

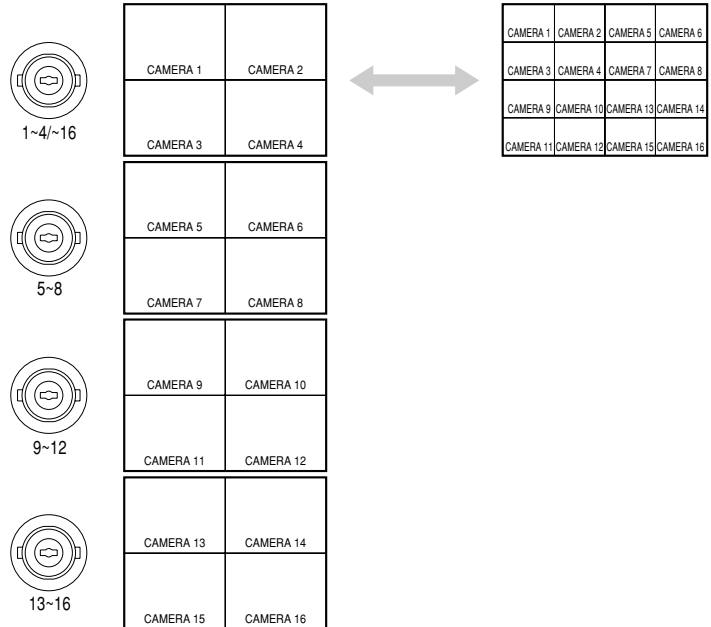

Notes

- When the monitor is connected to the [EE OUT] terminal and only one camera is set to "ON" among the "CAMERA 1" ~ "CAMERA 4" items for each "BLOCK" (1-4) in the "REC MODE" Menu (page 24), only a single screen will be displayed on the monitor even when "1-4" has been selected in the "MONITOR DISPLAY" Menu (page 26). Screens will be displayed in the quad picture when "1-16" is selected.
- When all the items in "CAMERA 1" ~ "CAMERA 4" (when Block 1 is selected) is set to "OFF" in the "REC MODE" Menu (page 24), the display turns black and recording is not executed.

Displaying in the 16 Split Screen Mode

1. Press the [MENU] button

- Follow procedures in 'Changing Menu Settings' on page 22 to display the "MONITOR DISPLAY" Menu.

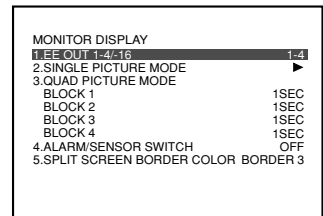
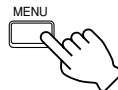

2. Press [▽] to move the cursor to "EE OUT 1-4/16"



3. Turn the jog dial to select "1-16"

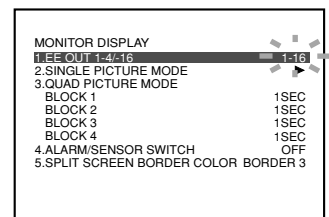
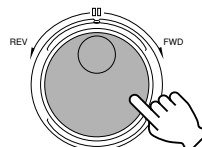

4. Press [MENU] to end setting

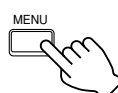

When connecting the monitor to the [VIDEO OUT] terminal

Display of live images, playback of recorded images and display of menu screens on the monitor are possible when it is connected to the [VIDEO OUT] terminal.

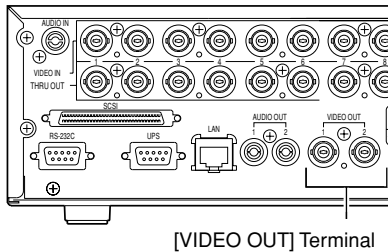

[VIDEO OUT] Terminal

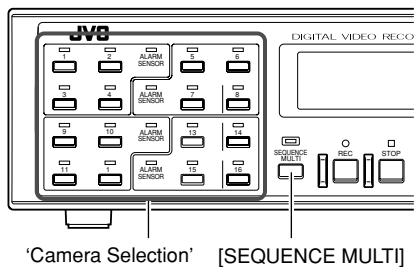

'Camera Selection' [SEQUENCE MULTI]

Notes

- Camera Selection buttons can be used to select cameras only when multiple cameras are set to "ON" among the "CAMERA 1" ~ "CAMERA 4" items for each "BLOCK" (1-4) in the "REC MODE" Menu (page 24). When cameras that are set to "OFF" are selected, the monitor will output a black image. If only 1 camera is set to "ON" in each block, the monitor will only display image of cameras in the "ON" mode.
- When switching the screen using the [SEQUENCE MULTI] button, the display image prior to switching will freeze for an instant.

- The following screen will be displayed on the monitor upon pressing the 'Camera Selection' buttons:



Lights up

: Screen switches in the following order each time the button is pressed.

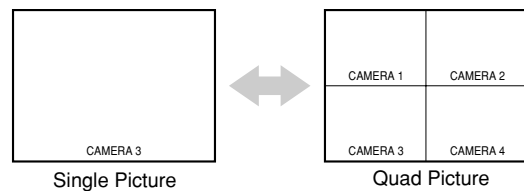

- The following screen will be displayed on the monitor upon pressing the [SEQUENCE MULTI] button:



SEQUENCE MULTI

: Screen switches in the following order each time the button is pressed.

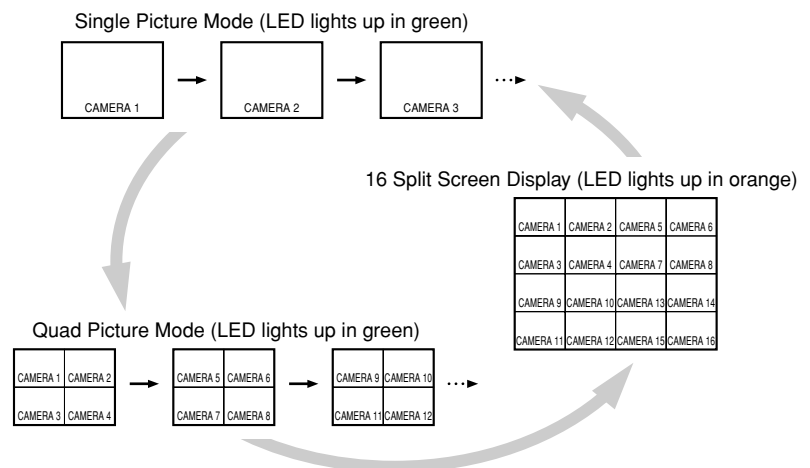

- Refer to page 34 on setting the time interval for switching displays when in the Single Picture mode.
- Refer to page 35 on setting the time interval for switching displays when in the Quad Picture mode.

Routine Uses (continued)

Viewing Live Camera Images

Setting Time Interval for Switching Displays in the Single Picture Mode

This enables the monitor to display images from Camera 1 ~ Camera 16 by switching from one camera to another according to the preset time interval.

Connect the monitor to the [VIDEO OUT] terminal.

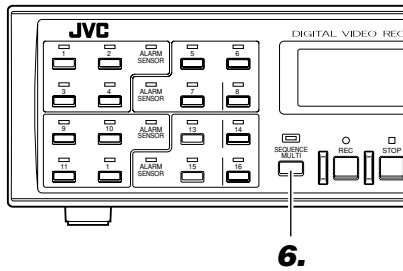
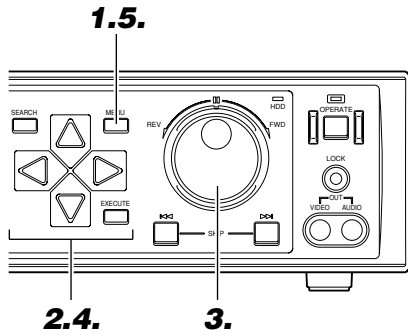

1. Press the [MENU] button

- Follow procedures in 'Changing Menu Settings' on page 22 to display the "MONITOR DISPLAY" Menu and the "SINGLE PICTURE MODE" screens.

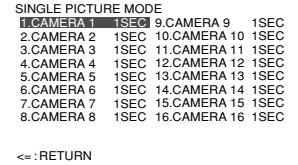

2. Press [▽] to select a camera no.

- Move the cursor to the camera no. for which monitor display time is to be altered.

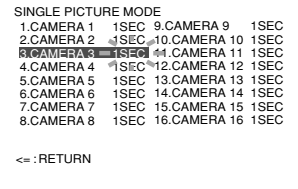
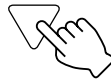

3. Turn the jog dial to select the monitor display time

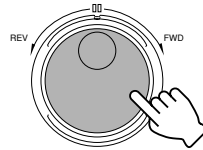

- Clockwise direction: Increases the time value.
- Anti-clockwise direction: Decreases the time value.

4. Move the cursor to "<=>: RETURN" using [▽] and press [◀]

- This returns the screen display to the "MONITOR DISPLAY" Menu.

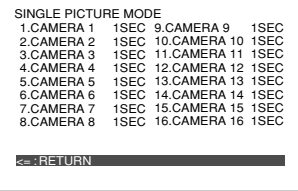

5. Press [MENU] to end setting

- The display returns to the normal screen.

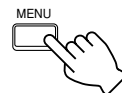

6. Press [SEQUENCE MULTI] to select the Single Picture mode

- Monitor starts to switch its display automatically.
- LED lights up in green.

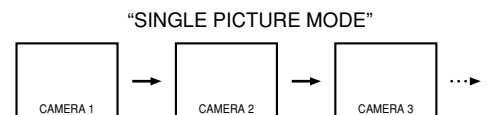
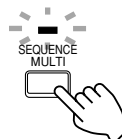

Note

- Display in the Single Picture mode is possible only when the "CAMERA 1" ~ "CAMERA 4" items are set to "ON" for each block in the "REC MODE" Menu (page 24) and the "SINGLE PICTURE MODE" item in the "MONITOR DISPLAY" Menu (page 26) is not set to "OFF".

Setting Time Interval for Switching Displays in the Quad Picture Mode

Monitor will display images of each block ("BLOCK 1": "CAMERA 1" ~ "CAMERA 4", "BLOCK 2": "CAMERA 5" ~ "CAMERA 8", "BLOCK 3": "CAMERA 9" ~ "CAMERA 12", "BLOCK 4": "CAMERA 13" ~ "CAMERA 16") in quad picture by switching from one block to another.

Connect the monitor to the [VIDEO OUT] terminal.

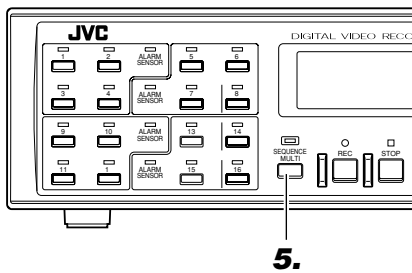
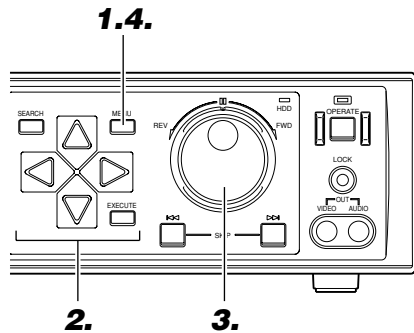

1. Press the [MENU] button

- Follow procedures in 'Changing Menu Settings' on page 22 to display the "MONITOR DISPLAY" Menu.

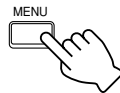

MONITOR DISPLAY	
1.EE OUT 1-4/16	1-4
2.SINGLE PICTURE MODE	▶
3.QUAD PICTURE MODE	
BLOCK 1	1SEC
BLOCK 2	1SEC
BLOCK 3	1SEC
BLOCK 4	1SEC
4.ALARM/SENSOR SWITCH	OFF
5.SPLIT SCREEN BORDER COLOR	BORDER 3

2. Press [▽] to select a block under the "QUAD PICTURE MODE" item

- Move the cursor to the camera block no. for which monitor display time is to be altered.



MONITOR DISPLAY	
1.EE OUT 1-4/16	1-4
2.SINGLE PICTURE MODE	▶
3.QUAD PICTURE MODE	
BLOCK 1	1SEC
BLOCK 2	1SEC
BLOCK 3	3SEC
BLOCK 4	1SEC
4.ALARM/SENSOR SWITCH	OFF
5.SPLIT SCREEN BORDER COLOR	BORDER 3

3. Turn the jog dial to select the monitor display time

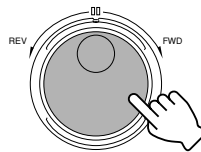

4. Press [MENU] to end setting

- The display returns to the normal screen.

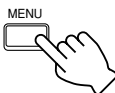

5. Press [SEQUENCE MULTI] to select the Quad Picture mode

- Monitor starts to switch its display automatically in quad picture.
- LED lights up in green.

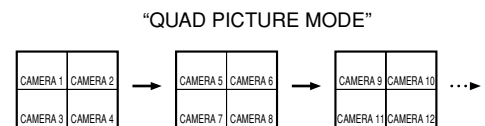
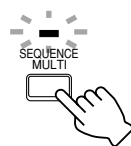

Notes

- Display in the Quad Picture mode is possible only when multiple cameras are set to "ON" in the corresponding block of the "REC MODE" Menu (page 24) and the "QUAD PICTURE MODE" item in the "MONITOR DISPLAY" Menu (page 26) is not set to "OFF". Monitor will display in the single picture if only one camera is set to "ON" in the block.
- Camera images for each block are displayed in the layout as follows:

"BLOCK 1":

CAMERA 1	CAMERA 2
CAMERA 3	CAMERA 4

"BLOCK 2":

CAMERA 5	CAMERA 6
CAMERA 7	CAMERA 8

"BLOCK 3":

CAMERA 9	CAMERA 10
CAMERA 11	CAMERA 12

"BLOCK 4":

CAMERA 13	CAMERA 14
CAMERA 15	CAMERA 16

Routine Uses (continued)

Recording Camera Images

Recording in the Normal Mode

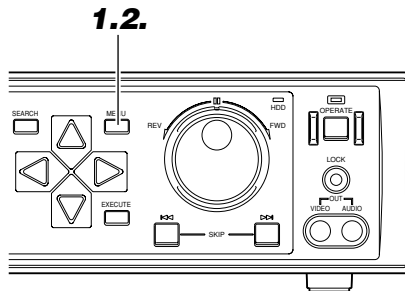

1. Press the [MENU] button

- Display the “REC MODE” Menu by following the procedures in ‘Changing Menu Settings’ on page 22 and specify settings for menu items required for recording.

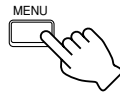

- Main menu items related to recording:

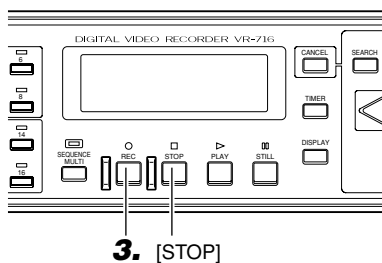

REC MODE		
1.BLOCK	1	ON
2.CAMERA 1		OFF
3.CAMERA 2		OFF
4.CAMERA 3		OFF
5.CAMERA 4		OFF
6.FRAME RATE	25	IPS
7.REC QUALITY		H
8.AUDIO REC		ON
RECORDABLE HOUR		APPROX. 25H

Select the camera channel block for which recording mode is to be set.

- “BLOCK 1”: “CAMERA 1” ~ “CAMERA 4”
- “BLOCK 2”: “CAMERA 5” ~ “CAMERA 8”
- “BLOCK 3”: “CAMERA 9” ~ “CAMERA 12”
- “BLOCK 4”: “CAMERA 13” ~ “CAMERA 16”

Specify for each camera whether to execute recording.

Select the frame rate during recording. ※

Select the picture quality of the recording image. ※

Select whether to execute audio recording. ※

Displays an estimate of remaining recording time.

※ Specify settings for each block.

2. Press [MENU] to end setting

- This exits the menu to return to the normal screen.

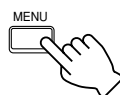

Notes

- Recording will not be executed if all cameras within a block are set to “OFF” in Step 1.
- Audio recording will be disabled if “1/6 IPS” or “1/12 IPS” is selected for “FRAME RATE”.

3. Press the [REC] button

- The recording mark [○] on the front display lights up and recording starts.

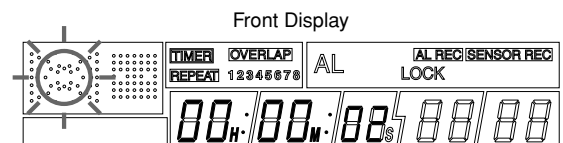
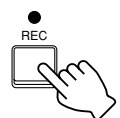

To stop recording

Press the [STOP] button

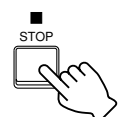

Repeat Recording (Repeat Record Feature)

VR-716 comes equipped with a Repeat Record feature that returns to the start point and overwrites old data when there is insufficient hard disk space.

☞ Page 112 'Repeat Record'

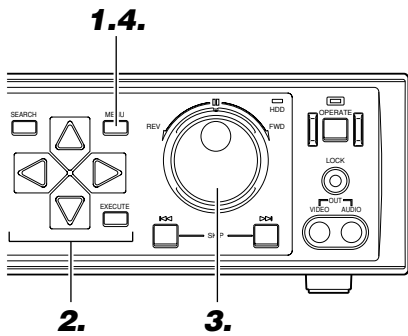

1. Press the [MENU] button

- Follow procedures in 'Changing Menu Settings' on page 22 to display the "OPERATION/EXT REC" Menu.

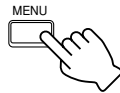

OPERATION/EXT REC		PRIOR STATE
[OPERATION]		
1.RECOVERY REC		OFF
2.REPEAT REC		OFF
3.LANGUAGE SELECTION		ENGLISH
4.WATER MARK		OFF
5.OPERATION LOCK		ALL
[EXT REC]		
1.EXT REC MODE		OFF
2.SERIES REC		OFF

2. Press [▽] to select the "REPEAT REC" item

- Move the cursor to select.

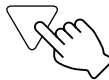

3. Turn the jog dial to select the mode of repeat recording

☞ Page 112 'Repeat Record'

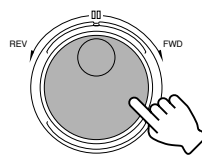

OPERATION/EXT REC		PRIOR STATE
[OPERATION]		
1.RECOVERY REC		OFF
2.REPEAT REC		OFF
3.LANGUAGE SELECTION		ENGLISH
4.WATER MARK		OFF
5.OPERATION LOCK		ALL
[EXT REC]		
1.EXT REC MODE		OFF
2.SERIES REC		OFF

4. Press [MENU] to end setting

- This exits the menu to return to the normal screen.

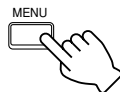

5. Press the [REC] button

- The recording mark [○] as well as the [REPEAT] indicator on the front display light up and recording starts.

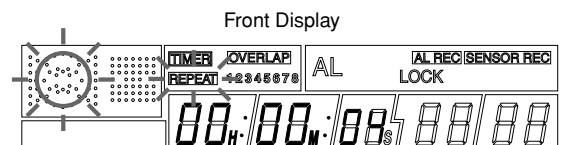
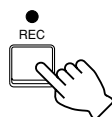

Routine Uses (continued)

Viewing Recorded Images

Playing Back Recorded Images

Play back the recorded images. To do so, search according to the date of the image to be played back using "DATE/TIME SEARCH" (☞ page 40) or according to the time when alarm/sensor signals are received using the "ALARM/SENSOR SEARCH" feature (☞ page 41).

Connect the monitor for viewing the playback image to the [VIDEO OUT] terminal.

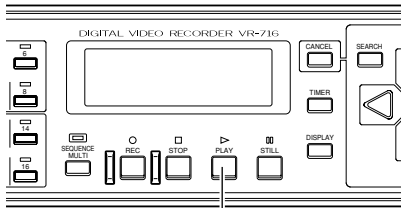

2.

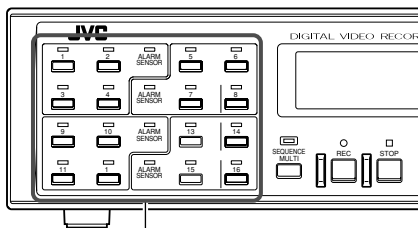

3. 'Camera Selection'

1. Search for the image to view

- Search according to the date of the image. (☞ page 40)
- Search according to alarm data. (☞ page 41)

2. Press the [PLAY] button

- The playback mark [▷] on the front display lights up and playback starts.

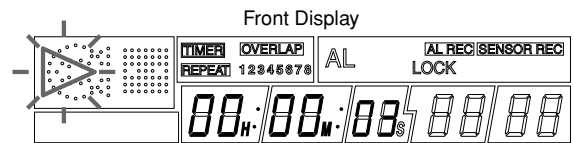

3. Press the 'Camera Selection' button

- Select the camera no. for which its image is to be displayed on the monitor.

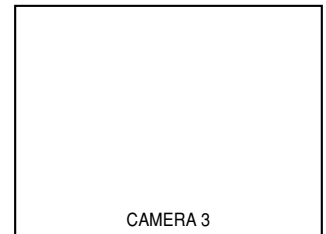
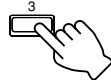

To stop playback temporarily

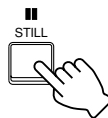

- Stops playback temporarily. To restart playback, press the [PLAY] button.

To stop playback

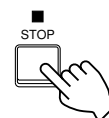

- Stops playback. Upon stopping, the display switches to the live camera image. Image may be distorted for an instant upon switching.

Notes

- Playback is possible regardless of the order in Steps 1 and 2.
- When in the Simultaneous Playback mode that enables playback and recording at the same time, press the [STOP] button once to stop playback, and press the [STOP] button again to stop recording.
- If no matching image is found in the selected camera no. during the specified date/time in Step 2, the "SPECIFIED IMAGE IS NOT RECORDED" and "JUMP WITH SKIP BUTTON" messages will be displayed on the screen.
- When in the Simultaneous Playback mode and playback is executed immediately after recording starts, the "NO PLAYBACK POSSIBLE IMAGES" message will appear on the screen. In this case, press the [PLAY] button again after recording has continued for about 1 minute.

Caution

- Refer to the notes related to Summer Time. (☞ Page 116)

Playing Back During Recording (Simultaneous Playback Mode)

Viewing of recorded images is possible when in the Recording mode.

This will not affect the images recorded.

- The playback mark [▷] and the recording mark [○] on the front display will blink alternately.

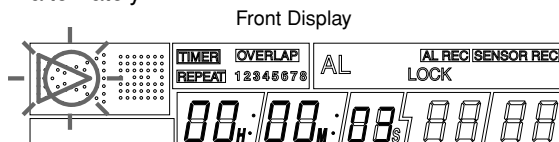

The following modes of playback are possible when in the Simultaneous Playback mode:

- Normal playback
 - Direct Jump Playback
 - Jog/Shuttle Playback
 - Skip Playback
- ☞ Page 40 'Searching Image According to Date/Time'
- ☞ Page 42 'Adjusting Playback Speed'
- ☞ Page 43 'Viewing Recorded Images in the Skip Mode'

Viewing Recorded Images in the Split Screen Mode

Connect the monitor for viewing the playback image to the [VIDEO OUT] terminal.

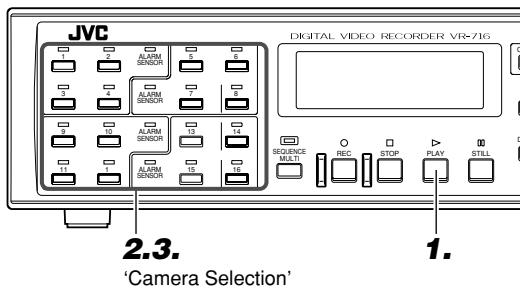

Notes

- If there is no image in the selected camera no., the "SPECIFIED IMAGE IS NOT RECORDED" message will be displayed. In this case, jump using the [SKIP] button.
- Display in the Split Screen mode is possible only when multiple cameras are set to "ON" for the selected camera block in the "REC MODE" Menu (Page 24).
- When selecting cameras from different blocks, images may distort or error may occur in the time display if the "REC MODE" Menu settings (Page 24) vary across the blocks.
- Recorded images cannot be viewed in 16 Split pictures.

1. Press the [PLAY] button

- The playback mark [▷] on the front display lights up and playback starts.

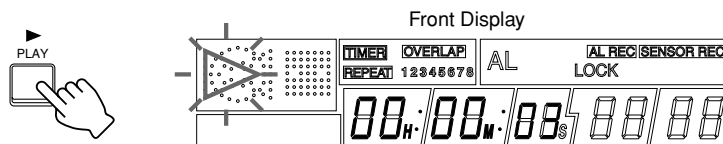

2. Press the 'Camera Selection' button

- Select the camera no. for which its image is to be displayed on the monitor.

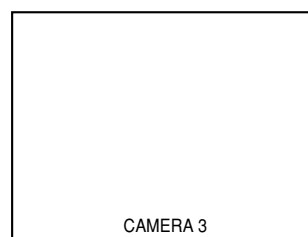
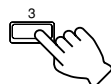

3. Press the 'Camera Selection' button again

- Monitor will display in quad picture.

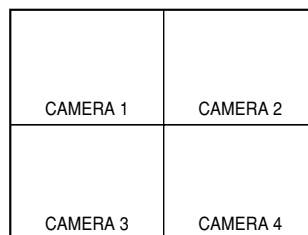
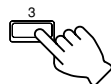

To exit quad picture

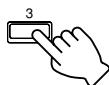

- Press the 'Camera Selection' button. Image of the selected camera no. will be played back on the monitor.

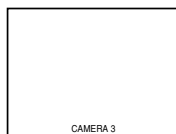

To view image of other cameras in the Split Screen

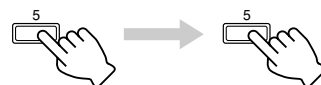

- Select the camera no. to be displayed on the monitor by pressing the 'Camera Selection' button twice.

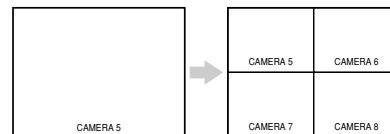

Routine Uses (continued)

Viewing Recorded Images

Searching Image According to Date/Time (“DATE/TIME SEARCH”)

Connect the monitor for viewing the playback image to the [VIDEO OUT] terminal.

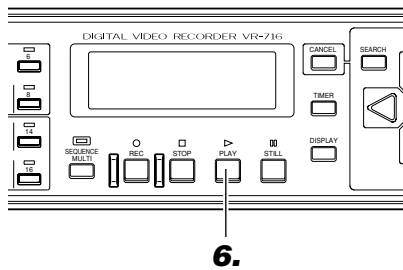
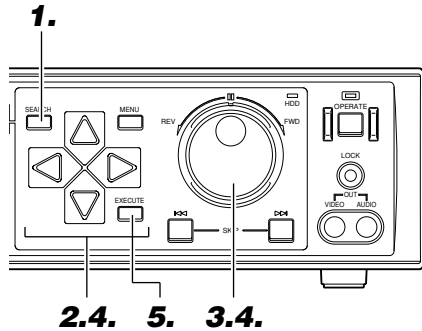

1. Press the [SEARCH] button

- This displays the “SEARCH MENU” screen.



```
SEARCH MENU
1.SEARCH SETTING                LATEST
2.DATE/TIME SEARCH
3.ALARM/SENSOR SEARCH
4.SKIP MODE                      ALARM
5.TIME JUMP SETTING             1 HOUR
```

2. Move the cursor to “DATE/TIME SEARCH” using [▽] and press [▶]

- This displays the “DATE/TIME SEARCH” screen.



```
DATE/TIME SEARCH
D   M   Y   H   M
15  07  2003  12  28

<=:RETURN
[EXEC]:SEARCH
```

3. Turn the jog dial to select a “D” (Day) value

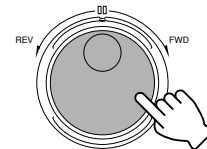

```
DATE/TIME SEARCH
D   M   Y   H   M
15  07  2003  12  28
```

- Clockwise direction: Increases the value.
- Anti-clockwise direction: Decreases the value.

4. Press [▶] and turn the jog dial to select a “M” (Month) value

- Next, use [▶] and the jog dial to select the “Y” (Year), “H” (Hour) and “M” (Minute) values accordingly.

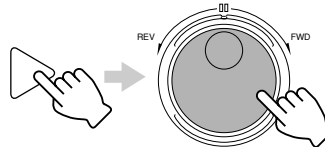

```
DATE/TIME SEARCH
D   M   Y   H   M
15  07  2003  12  28
```

5. Press the [EXECUTE] button

- This starts the Date/Time Search. Upon completion of search, image of the selected date/time will be displayed in the Still mode.



6. Press the [PLAY] button

- This starts the playback of the image that is retrieved according to the date/time.

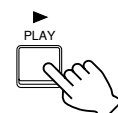

Notes

- Date/Time Search can be performed when in the Recording mode.
- If no image is found on the specified date/time, the recorded image of the next closest date will be displayed in the Still mode.
- When “LATEST” is selected during specification of Date/Time Search, the current time will be displayed as the date/time in the “DATE/TIME SEARCH” screen. When “PREVIOUS” is selected, the date/time of the previous search will be displayed. Memory will be cleared upon turning off the power and time display switches to the current time. (This is also applicable during “ALARM/SENSOR SEARCH” as described in page 41.)
- The order of D/M/Y will change in accordance with the “DATE DISPLAY” setting in the “ONSCREEN MODE” menu.

Caution

- Refer to the notes related to Summer Time. (Page 116)

Searching Image According to Alarm/Sensor Data ("ALARM/SENSOR SEARCH")

Connect the monitor for viewing the playback image to the [VIDEO OUT] terminal.

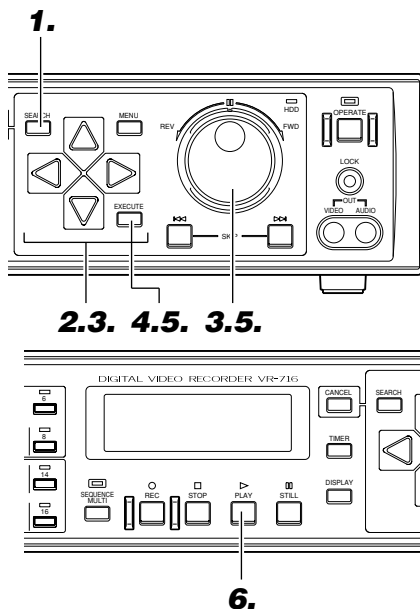

<How to clear the Alarm Record List>

- Press the [CANCEL] button when in the "ALARM/SENSOR SEARCH" screen.
 - A screen to confirm deletion of the alarm records will be displayed. Press the [EXECUTE] button.
 - This deletes the entire Alarm Record List within the hard disk. (To cancel the delete operation, press the [CANCEL] button.)
- Alarm data will be cleared upon deleting the Alarm Record List, and Alarm Search will be disabled. In this case, images recorded during alarm recording are not deleted but are converted into images in the normal recording mode.
- Deletion of the Alarm Record List is not possible when in the Recording mode. (The "[CANCEL]: LIST CLEAR" display will disappear.)

Notes

- A maximum of 4 camera Nos. may be recorded in each Alarm List when multiple alarms are simultaneously triggered. Playback in this case will start from the image of the smallest camera No.. To view image of other cameras, select accordingly using the Camera Selection buttons.
- If there is no alarm record on the specified date/time, the next closest alarm record will be selected.
- When the Alarm List is displayed, the [SKIP] button can be used to jump scroll the list in units of 100 records.
- When the Alarm No. in the alarm search list exceeds 7 digits, only the lower 6 digits will be displayed.
- As searching will take time when there is an increase in the number of alarms, frequent usage to receive alarms is not recommended.

1. Press the [SEARCH] button

- This displays the "SEARCH MENU" screen.



```
SEARCH MENU
1.SEARCH SETTING          LATEST
2.DATE/TIME SEARCH
3.ALARM/SENSOR SEARCH
4.SKIP MODE              ALARM
5.TIME JUMP SETTING      1HOUR
```

2. Move the cursor to the "ALARM/SENSOR SEARCH" item using [▽] and press [▶]

- This displays the "ALARM/SENSOR SEARCH" screen.



```
ALARM/SENSOR SEARCH
  D    M    Y    H    M
 15   07  2003  12  28
No.  CAMERA D M Y H M S
*****
*****
*****
*****
*****
*****
*****
*****
*****
*****
<=: RETURN
[CANCEL]:LIST CLEAR [EXEC]:SEARCH
```

3. Turn the jog dial to select a "D" (Day) value

- Next, use [▶] and the jog dial to select the "M" (Month), "Y" (Year), "H" (Hour) and "M" (Minute) values accordingly.

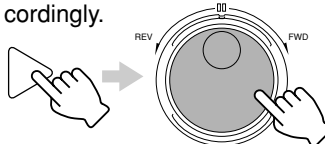

```
ALARM/SENSOR SEARCH
  D    M    Y    H    M
 15   07  2003  12  28
No.  CAMERA D M Y H M S
*****
*****
*****
*****
*****
*****
*****
*****
*****
*****
<=: RETURN
[CANCEL]:LIST CLEAR [EXEC]:SEARCH
```

4. Press the [EXECUTE] button

- This starts the Alarm Search. Upon completion of search, the Alarm List on or about the specified date/time will be displayed in order starting from the most current record.



```
ALARM/SENSOR SEARCH
  D    M    Y    H    M
 15   07  2003  12  28
No.  CAMERA D M Y H M S
*****
*****
*****
*****
000002  5 6 7 8 16-07-2003 10:10:10
000001  1 2 3 4 15-07-2003 10:10:10
*****
*****
*****
*****
*****
*****
*****
*****
<=: RETURN
[CANCEL]:LIST CLEAR [EXEC]:SEARCH
```

5. Turn the jog dial and press [EXECUTE] to select the alarm to view

- Image of the selected alarm will be displayed in the Still mode.

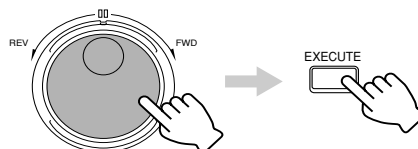

```
ALARM/SENSOR SEARCH
  D    M    Y    H    M
 15   07  2003  12  28
No.  CAMERA D M Y H M S
*****
*****
*****
*****
000002  5 6 7 8 16-07-2003 10:10:10
000001  1 2 3 4 15-07-2003 10:10:10
*****
*****
*****
*****
*****
*****
*****
*****
<=: RETURN
[CANCEL]:LIST CLEAR [EXEC]:SEARCH
```

6. Press the [PLAY] button

- This starts the playback of the selected alarm image.



Routine Uses (continued)

Viewing Recorded Images

Adjusting Playback Speed (Jog/Shuttle Playback)

Playback speed can be adjusted by turning the jog/shuttle dial. This feature is very useful when searching for a specific screen for viewing.

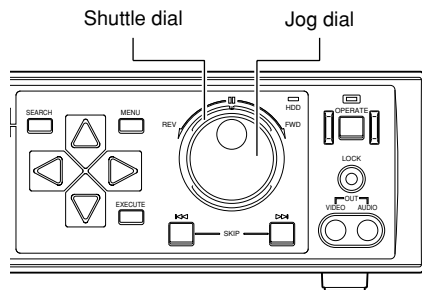

Turn the shuttle dial

When in the Playback mode

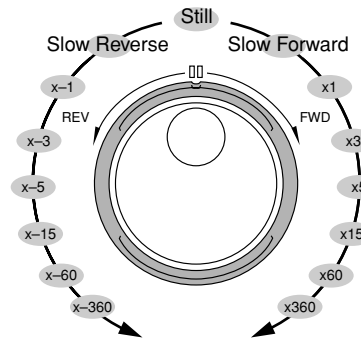

This starts the Slow Motion Playback as well as the Fast Forward and Fast Reverse Playback modes.

Turn the jog dial

When in the Playback mode

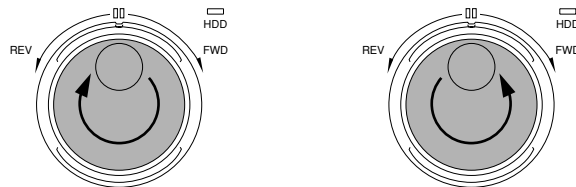

Starts frame-by-frame playback in the forward direction.

Starts frame-by-frame playback in the reverse direction.

- When the jog dial is turned, frame-to-frame playback is performed. Playback switches to the Still mode upon releasing the dial.

Press the [STOP] or [PLAY] button to stop Jog Playback/Shuttle Playback

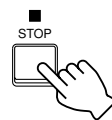

- Monitor display switches to the live camera image.

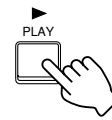

- Monitor display switches to the normal playback screen.

Note

- Frame rate when turning the jog dial at a faster speed may be lower as compared with when turning it at a slower speed.

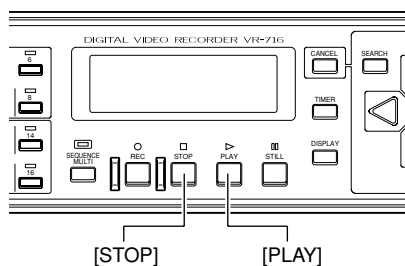

Viewing Recorded Images in the Skip Mode

Connect the monitor for viewing the playback image to the [VIDEO OUT] terminal.

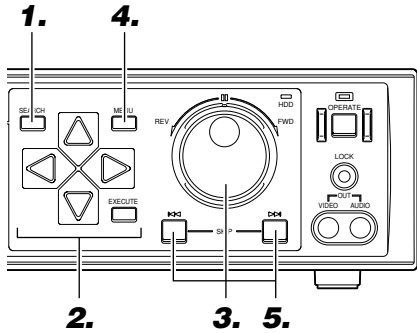

Note

- The "TIME JUMP SETTING" can be specified by selecting one of the following: "1MIN", "5MIN", "10MIN", "30MIN", "1HOUR", "4HOURS", "1DAY", "1WEEK" ("1HOUR" is selected in the factory settings.)

Caution

- When in the Stop mode, pressing the [SKIP] button (◀◀) jumps to the oldest event while pressing the [SKIP] button (▶▶) jumps to the most current event.
- Time Jump cannot be executed if the date/time is not set.
Set the date/time in advance.
☞ Page 18 'Setting the Date/Time'

1. Press the [SEARCH] button

- This displays the "SEARCH MENU" screen.

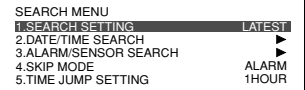

2. Press [▽] to select the "SKIP MODE" item

- Move the cursor to select.



3. Turn the jog dial to select a Skip mode

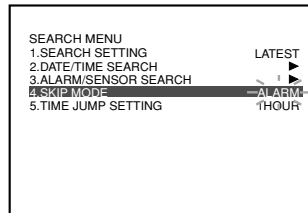

"TIME" : Time Jump Setting
"ALARM" : Alarm Jump Setting
"EVENT" : Event Jump Setting

4. Press [MENU] to end setting

- This exits the menu to return to the normal screen.

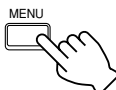

5. Press the [SKIP] button when in the Playback mode

- Pressing the button skips the playback image.

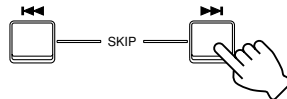

◀◀ : Jumps from the current playback image to an old image and displays it in the Still mode.

▶▶ : Jumps from the current playback image to a new image and displays it in the Still mode.

■ To select the Time Jump interval

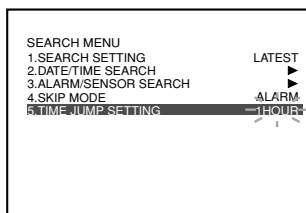

Select using the "TIME JUMP SETTING" item in the "SEARCH MENU" screen.

☞ Page 114 'Skip Jump'

Routine Uses (continued)

Viewing Recorded Images

Enlarging the Still Image (Still Image Zoom)

Still images can be viewed in an enlarged mode.

Connect the monitor for viewing the playback image to the [VIDEO OUT] terminal.

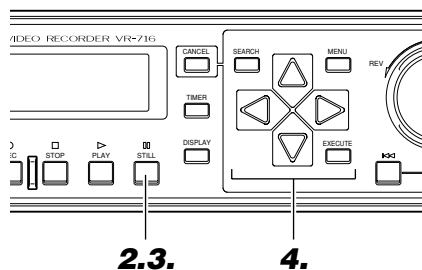

1. Playback the image

- Perform Steps 1 ~ 3 of 'Playing Back Recorded Images' on page 38.

2. Press the [STILL] button

- Press the button at the point for which display is to be enlarged.

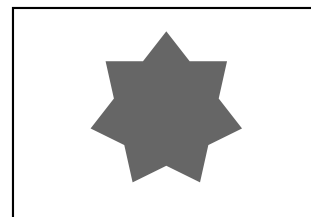

3. Press and hold the [STILL] button for a while

- A Guide Box for specifying the zoom area will be displayed on the screen.

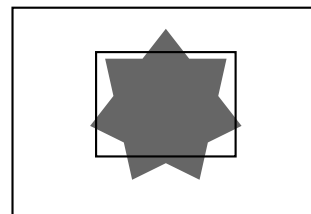

Notes

- Still image cannot be enlarged when playback screen is in quad.
- Pressing the [CANCEL] button during setting exits the Still Image Zoom mode.

4. Move using the [/ / /] buttons

- Move the Guide Box to the position on the image that is to be enlarged.
- The position can be moved diagonally by pressing buttons simultaneously.

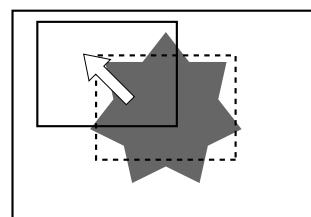
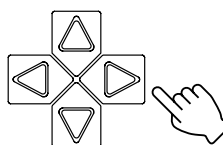

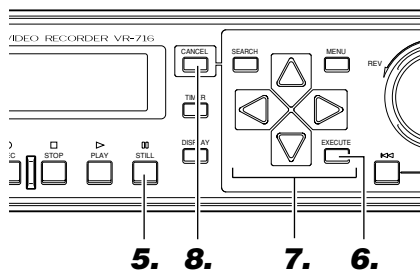

5. Press the [STILL] button

- Each time the [STILL] button is pressed, x2 Zoom or x4 Zoom in both vertical and horizontal directions can be selected.

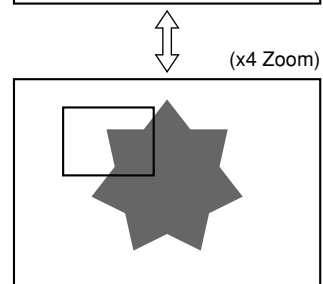
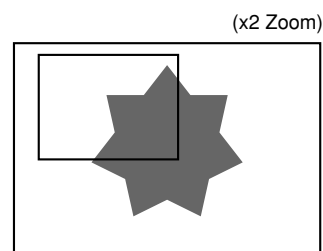

6. Press the [EXECUTE] button

- The portion within the Guide Box will be displayed in full screen.

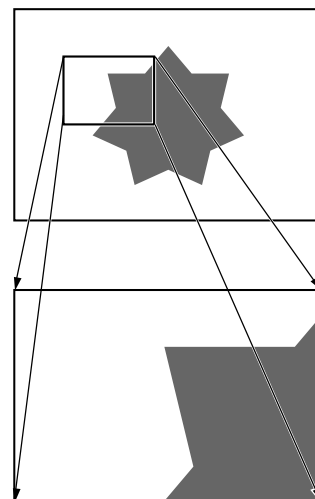

Notes

- Still image cannot be enlarged when playback screen is in quad.
- Pressing the [CANCEL] button during setting exits the Still Image Zoom mode.

7. Scroll using the [△ / ▽ / ◀ / ▶] buttons

- The zoom screen can be scrolled by pressing the buttons in the direction to be viewed.
- It can be moved diagonally by pressing buttons simultaneously.

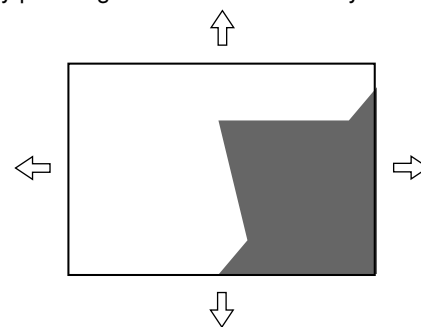
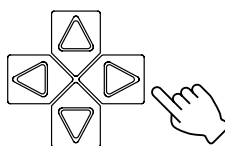

8. Press the [CANCEL] button

- This exits the Zoom mode.
- Press [PLAY] to return to the normal playback mode.

Routine Uses (continued)

Record Programming Using the Program Timer

Weekly Timer (For starting recording on a specific day and time on a weekly basis)

<Example>
Execute recording from 8:00 a.m. every Friday ~ 5:00 p.m. every Saturday.

■ Recording Mode

- Cameras 1 - 4
 - “FRAME RATE” : “12.5 IPS”
 - “REC QUALITY” : “H”
 - “AUDIO REC” : “A” (ON)
- Cameras 5 - 8
 - “FRAME RATE” : “25 IPS”
 - “REC QUALITY” : “N”
 - “AUDIO REC” : “A” (ON)
- Cameras 9 - 12
 - “FRAME RATE” : “2.5 IPS”
 - “REC QUALITY” : “N”
 - “AUDIO REC” : – (OFF)
- Cameras 13 - 16
 - “FRAME RATE” : “1/2 IPS”
 - “REC QUALITY” : “B”
 - “AUDIO REC” : – (OFF)

1. Press the [MENU] button

- Follow procedures in ‘Changing Menu Settings’ on page 22 to display the “PROGRAM TIMER” Menu and the “WEEKLY TIMER” Menu screens.

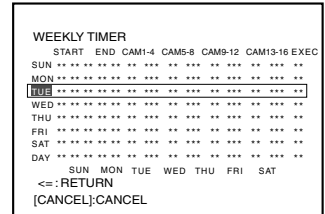
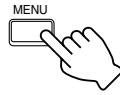

2. Press [▽] to select the line for which program is to be set

- For example, move the cursor to the third line. (Program can be set for any line.)



3. Turn the jog dial to adjust the starting day to “FRI” (Friday)

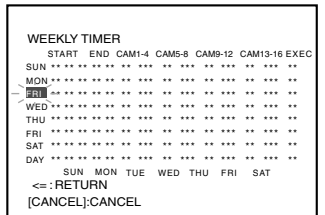
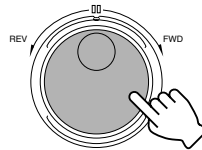

4. Press [▶] to move cursor to the Hour position under the “START” column, and turn the jog dial to select “08”

- To set the minute value of the starting time, press [▶] to move cursor to the Minute position and adjust by turning the jog dial.

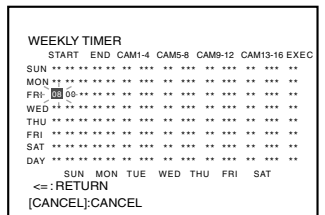
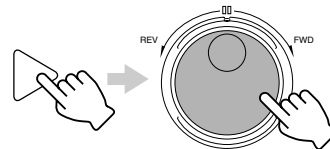

5. Press [▶] to move cursor to the Day of the Week position under the “END” column, and turn the jog dial to select “SAT” (SATURDAY)

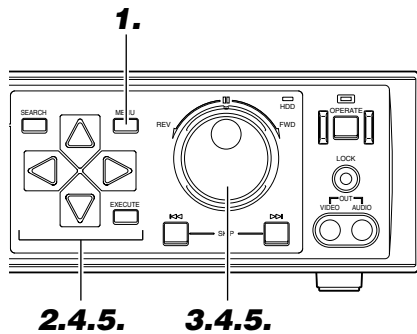
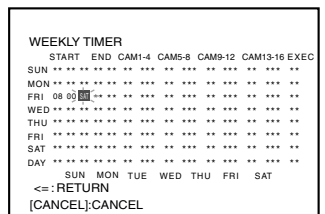
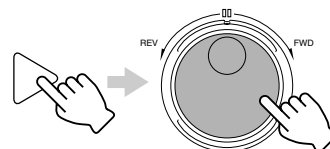

Notes

- Only 1 line on the “WEEKLY TIMER” Menu is executed at any one time and there will be no simultaneous execution of multiple lines.
- Upon pressing the [TIMER] button when there is an overlap in the program, the [OVERLAP] wording on the front display will light up, blink for about 10 seconds and continue to remain lit. When an overlap occurs between programs in the Weekly Timer and Date Timer, the [OVERLAP] wording will not light up. In this case, priority is given to the Date Timer settings. When “DAY” is set in the “WEEKLY TIMER” Menu, [OVERLAP] will not be displayed even when it overlaps with other timer programs. In this case, priority will be given to the program with an earlier starting time.
- It may take about 20 seconds before [OVERLAP] is displayed.

Caution

- Refer to the notes related to Summer Time. (Page 116)

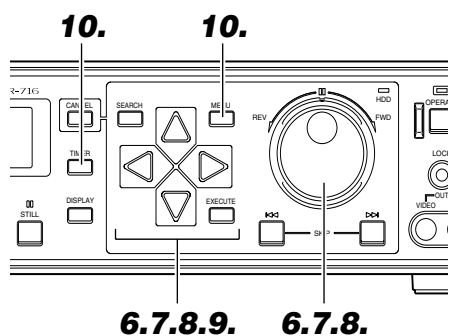

6. Press [▶] to move cursor to the *Hour* position under the “END” column, and turn the jog dial to select “17”

- To set the minute value of the ending time, press [▶] to move cursor to the *Minute* position and adjust by turning the jog dial.

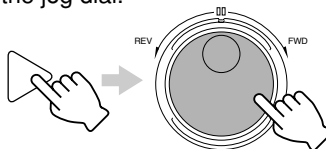
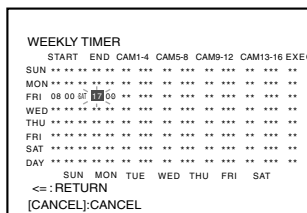

7. Press [▶] and turn the jog dial to set “FRAME RATE”, “REC QUALITY” and “AUDIO REC”

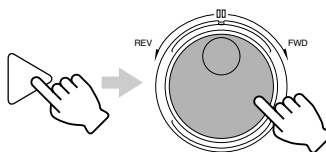
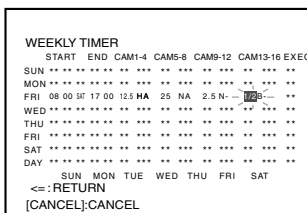

8. Press [▶] to move cursor to the “EXEC” column, and turn the jog dial to select “WLY”(WEEKLY)

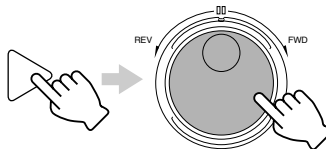
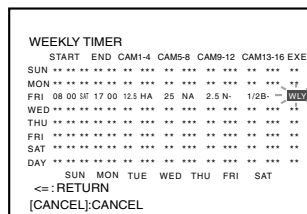

9. Move the cursor to “<=: RETURN” using [▽] and press [◀]

- This displays the “PROGRAM TIMER” Menu screen.

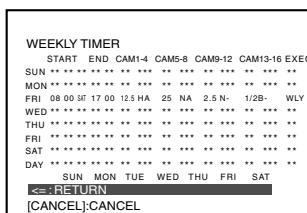

10. Press [MENU] to return to the normal screen, and press [TIMER]

- The Timer indicator on the front display lights up and switches to the Timer Standby mode.
- The Weekly Timer Program No. on the front display lights up. (The number of the line for which timer recording has been set will light up)

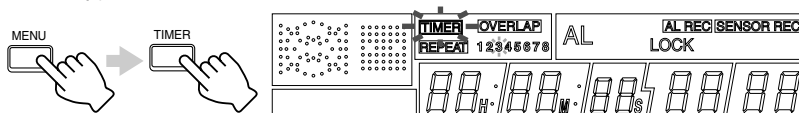

Notes

- The “FRAME RATE”, “REC QUALITY” and “AUDIO REC” settings of Block 1 (Cameras 1 - 4) will be automatically copied to the remaining blocks. To make alterations, do so by turning the jog dial.
- In the case of camera blocks for which recording is not to be executed, press the [CANCEL] button to clear the settings.
- Maximum duration of nonstop recording is less than 1 week.
- “FRAME RATE”, “REC QUALITY” and “AUDIO REC” settings can be specified for each Block (Cameras 1 - 4, Cameras 5 - 8, Cameras 9 - 12, Cameras 13 - 16).
- Timer mode will not be activated if the “AUDIO REC” setting remains as “*”. Make sure that this is changed to “A” or “_”.

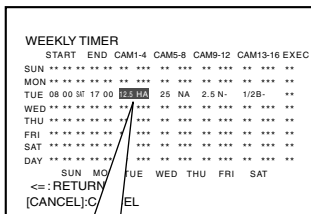

“FRAME RATE” “AUDIO REC”: ON
“REC QUALITY”

- When in the Timer Standby mode, turning OFF of the [OPERATE] button as well as recording operations will be disabled.
- When an invalid timer has been set, this invalid setting will be automatically deleted upon exiting the Timer screen. In this case, the “DELETE INVALID TIMER SETTING” message will be displayed on the screen. To clear this message, press the [CANCEL] button.

Caution

- When all the settings for cameras in a block (CAMERA 1 ~ CAMERA 4 / CAMERA 5 ~ CAMERA 8 / CAMERA 9 ~ CAMERA 12 / CAMERA 13 ~ CAMERA 16) under the “REC MODE” Menu (Page 24) are set to “OFF”, Program Timer Recording will not be activated for that block.

Routine Uses (continued)

Record Programming Using the Program Timer

Weekly Timer (For starting recording on a specific time of the day)

<Example>
 Execute recording from 8:00 a.m. ~ 5:00 p.m. everyday.
■ Recording Mode

- Cameras 1 - 4
 - "FRAME RATE" : "12.5 IPS"
 - "REC QUALITY" : "H"
 - "AUDIO REC" : "A" (ON)
- Cameras 5 - 8
 - "FRAME RATE" : "25 IPS"
 - "REC QUALITY" : "N"
 - "AUDIO REC" : "A" (ON)
- Cameras 9 - 12
 - "FRAME RATE" : "2.5 IPS"
 - "REC QUALITY" : "N"
 - "AUDIO REC" : - (OFF)
- Cameras 13 - 16
 - "FRAME RATE" : "1/2 IPS"
 - "REC QUALITY" : "B"
 - "AUDIO REC" : - (OFF)

1. Press the [MENU] button

- Follow procedures in 'Changing Menu Settings' on page 22 to display the "PROGRAM TIMER" Menu and the "WEEKLY TIMER" Menu screens.

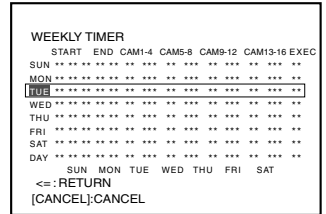
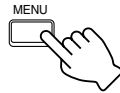

2. Press [▽] to select the line for which program is to be set

- For example, move the cursor to the third line. (Program can be set for any line.)



3. Turn the jog dial to select "DAY"

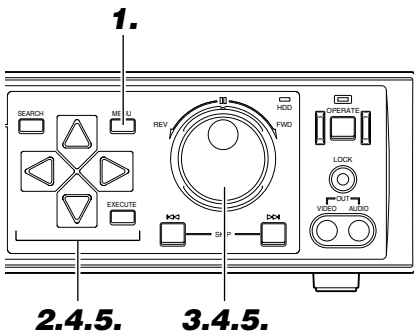
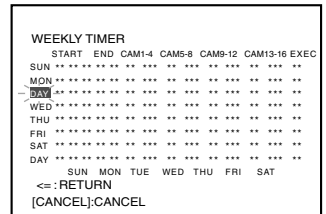
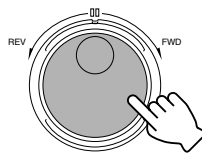

4. Press [▶] to move cursor to the Hour position under the "START" column, and turn the jog dial to select "08"

- To set the minute value of the starting time, press [▶] to move cursor to the Minute position and adjust by turning the jog dial.

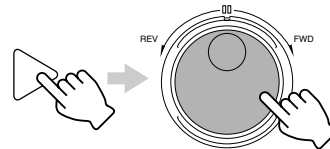
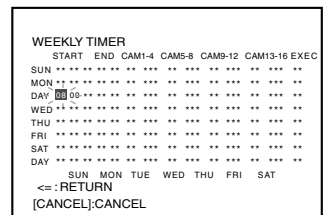

Note

- When "DAY" is selected for the starting day of the week, specification of ending day will not be necessary.

Caution

- Refer to the notes related to Summer Time. (Page 116)

5. Press [▶] to move cursor to the Hour position under the "END" column, and turn the jog dial to select "17"

- To set the minute value of the ending time, press [▶] to move cursor to the Minute position and adjust by turning the jog dial.

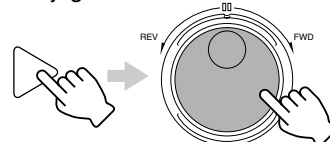
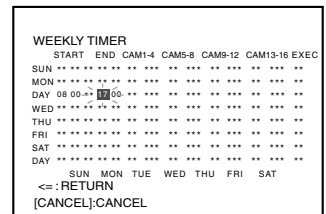

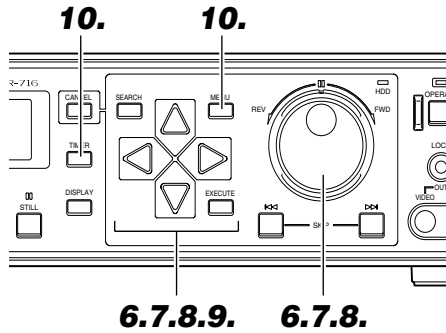

6. Press [▶] and turn the jog dial to set “FRAME RATE”, “REC QUALITY” and “AUDIO REC”

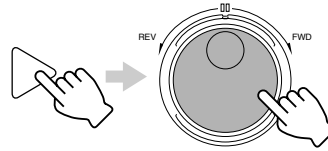

WEEKLY TIMER							
START	END	CAM1-4	CAM5-8	CAM9-12	CAM13-16	EXEC	
SUN	*****	*****	*****	*****	*****	*****	*****
MON	*****	*****	*****	*****	*****	*****	*****
DAY	08:00	** 17:00	12.5 HA	25 NA	2.5 N-	1/2B-	---
WED	*****	*****	*****	*****	*****	*****	*****
THU	*****	*****	*****	*****	*****	*****	*****
FRI	*****	*****	*****	*****	*****	*****	*****
SAT	*****	*****	*****	*****	*****	*****	*****
DAY	*****	*****	*****	*****	*****	*****	*****
	SUN	MON	TUE	WED	THU	FRI	SAT
<=:	RETURN						
[CANCEL]:	CANCEL						

Notes

- The “FRAME RATE”, “REC QUALITY” and “AUDIO REC” settings of Block 1 (Cameras 1 - 4) will be automatically copied to the remaining blocks. To make alterations, do so by turning the jog dial.
- In the case of camera blocks for which recording is not to be executed, press the [CANCEL] button to clear the settings.
- “FRAME RATE”, “REC QUALITY” and “AUDIO REC” settings can be specified for each Block (Cameras 1 - 4, Cameras 5 - 8, Cameras 9 - 12, Cameras 13 - 16).

WEEKLY TIMER							
START	END	CAM1-4	CAM5-8	CAM9-12	CAM13-16	EXEC	
SUN	*****	*****	*****	*****	*****	*****	*****
MON	*****	*****	*****	*****	*****	*****	*****
TUE	08:00	** 17:00	12.5 HA	25 NA	2.5 N-	1/2B-	---
WED	*****	*****	*****	*****	*****	*****	*****
THU	*****	*****	*****	*****	*****	*****	*****
FRI	*****	*****	*****	*****	*****	*****	*****
SAT	*****	*****	*****	*****	*****	*****	*****
DAY	*****	*****	*****	*****	*****	*****	*****
	SUN	MON	TUE	WED	THU	FRI	SAT
<=:	RETURN						
[CANCEL]:	CANCEL						

12.5 H A
 “FRAME RATE” “AUDIO REC”: ON
 “REC QUALITY”

- During “DAY” setting, ending time switches automatically to the following day if the ending time set is earlier than the starting time.
- When an invalid timer has been set, this invalid setting will be automatically deleted upon exiting the Timer screen. In this case, the “DELETE INVALID TIMER SETTING” message will be displayed on the screen. To clear this message, press the [CANCEL] button.

Caution

- Pay attention when changing the day of the week at the final line in Step 8. Other record program settings for which “DAY” has been selected will also be altered.
- Maximum duration of nonstop recording is less than 24 hours.
- When all the settings for cameras in a block (CAMERA 1 ~ CAMERA 4 / CAMERA 5 ~ CAMERA 8 / CAMERA 9 ~ CAMERA 12 / CAMERA 13 ~ CAMERA 16) under the “REC MODE” Menu (Page 24) are set to “OFF”, Program Timer Recording will not be activated for that block.

7. Press [▶] to move cursor to the “EXEC” column, and turn the jog dial to select “ON”

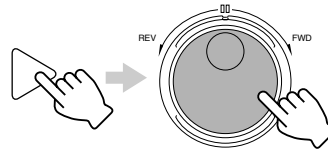

WEEKLY TIMER							
START	END	CAM1-4	CAM5-8	CAM9-12	CAM13-16	EXEC	
SUN	*****	*****	*****	*****	*****	*****	*****
MON	*****	*****	*****	*****	*****	*****	*****
DAY	08:00	** 17:00	12.5 HA	25 NA	2.5 N-	1/2B-	ON
WED	*****	*****	*****	*****	*****	*****	*****
THU	*****	*****	*****	*****	*****	*****	*****
FRI	*****	*****	*****	*****	*****	*****	*****
SAT	*****	*****	*****	*****	*****	*****	*****
DAY	*****	*****	*****	*****	*****	*****	*****
	SUN	MON	TUE	WED	THU	FRI	SAT
<=:	RETURN						
[CANCEL]:	CANCEL						

8. Press [▽] to move the cursor to the final line

- Check that “SUN” ~ “SAT” has been selected. When “--” is displayed, select the day of the week to execute recording using [▶] and the jog dial.

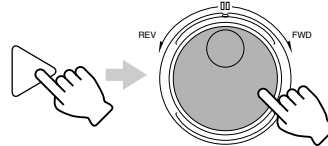

WEEKLY TIMER							
START	END	CAM1-4	CAM5-8	CAM9-12	CAM13-16	EXEC	
SUN	*****	*****	*****	*****	*****	*****	*****
MON	*****	*****	*****	*****	*****	*****	*****
DAY	08:00	** 17:00	12.5 HA	25 NA	2.5 N-	1/2B-	ON
WED	*****	*****	*****	*****	*****	*****	*****
THU	*****	*****	*****	*****	*****	*****	*****
FRI	*****	*****	*****	*****	*****	*****	*****
SAT	*****	*****	*****	*****	*****	*****	*****
DAY	*****	*****	*****	*****	*****	*****	*****
	SUN	MON	TUE	WED	THU	FRI	SAT
<=:	RETURN						
[CANCEL]:	CANCEL						

9. Move the cursor to “<=: RETURN” using [▽] and press [◀]

- This displays the “PROGRAM TIMER” Menu screen.



WEEKLY TIMER							
START	END	CAM1-4	CAM5-8	CAM9-12	CAM13-16	EXEC	
SUN	*****	*****	*****	*****	*****	*****	*****
MON	*****	*****	*****	*****	*****	*****	*****
DAY	08:00	** 17:00	12.5 HA	25 NA	2.5 N-	1/2B-	ON
WED	*****	*****	*****	*****	*****	*****	*****
THU	*****	*****	*****	*****	*****	*****	*****
FRI	*****	*****	*****	*****	*****	*****	*****
SAT	*****	*****	*****	*****	*****	*****	*****
DAY	*****	*****	*****	*****	*****	*****	*****
	SUN	MON	TUE	WED	THU	FRI	SAT
<=:	RETURN						
[CANCEL]:	CANCEL						

10. Press [MENU] to return to the normal screen, and press [TIMER]

- The Timer indicator on the front display lights up and switches to the Timer Standby mode.
- The Weekly Timer Program No. on the front display lights up. (The number of the line for which timer recording has been set will light up)

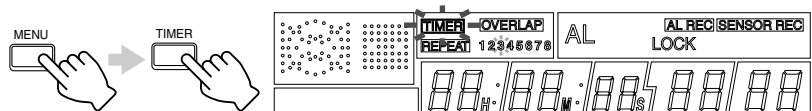

Routine Uses (continued)

Record Programming Using the Program Timer

Weekly Timer (For starting recording on a specific day of the week and time)

<Example>
 Execute recording from 9:30 a.m. ~ 10:30 p.m. on every Monday, Wednesday and Friday.

■ **Recording Mode**

- Cameras 1 - 4**
 - "FRAME RATE" : "12.5 IPS"
 - "REC QUALITY" : "H"
 - "AUDIO REC" : "A" (ON)
- Cameras 5 - 8**
 - "FRAME RATE" : "25 IPS"
 - "REC QUALITY" : "N"
 - "AUDIO REC" : "A" (ON)
- Cameras 9 - 12**
 - "FRAME RATE" : "2.5 IPS"
 - "REC QUALITY" : "N"
 - "AUDIO REC" : - (OFF)
- Cameras 13 - 16**
 - "FRAME RATE" : "1/2 IPS"
 - "REC QUALITY" : "B"
 - "AUDIO REC" : - (OFF)

1. Press the [MENU] button

- Follow procedures in 'Changing Menu Settings' on page 22 to display the "PROGRAM TIMER" Menu and the "WEEKLY TIMER" Menu screens.

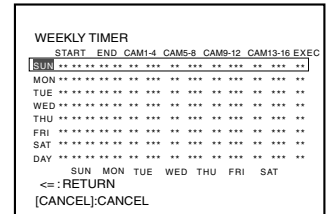
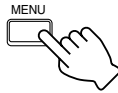

2. Press [▽] to select the line for which program is to be set

- For example, move the cursor to select the first line. (Program can be set for any line.)



3. Turn the jog dial to select "DAY"

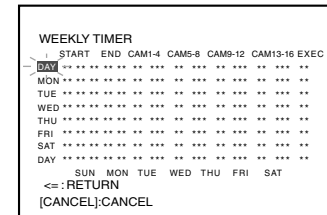
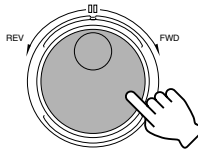
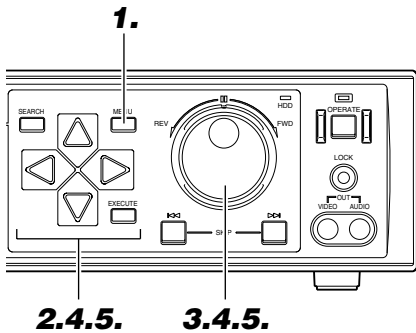

4. Press [▶] to move cursor to the Hour position under the "START" column, and turn the jog dial to select "09"

- To set the minute value of the starting time, press [▶] to move cursor to the Minute position and adjust by turning the jog dial.

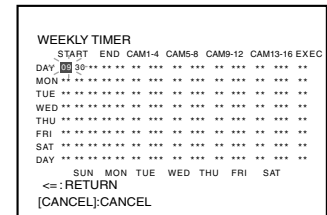
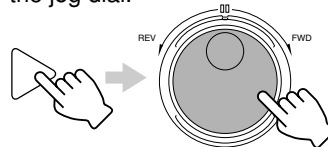

Note

- When "DAY" is selected for the starting day of the week, specification of ending day will not be necessary.

Caution

- Refer to the notes related to Summer Time. (Page 116)

5. Press [▶] to move cursor to the Hour position under the "END" column, and turn the jog dial to select "22"

- To set the minute value of the ending time, press [▶] to move cursor to the Minute position and adjust by turning the jog dial.

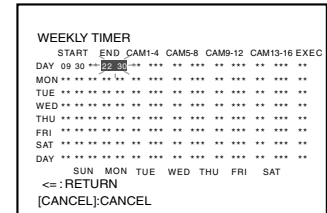
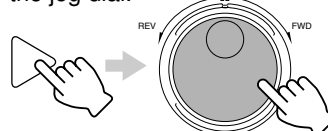

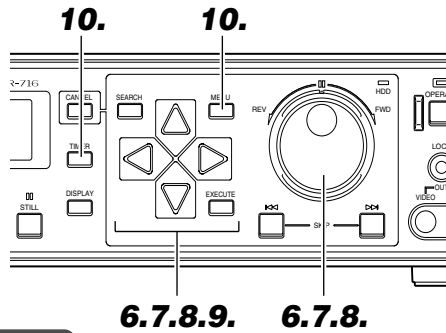

Notes

- The “FRAME RATE”, “REC QUALITY” and “AUDIO REC” settings of Block 1 (Cameras 1 - 4) will be automatically copied to the remaining blocks. To make alterations, do so by turning the jog dial.
- In the case of camera blocks for which recording is not to be executed, press the [CANCEL] button to clear the settings.
- “FRAME RATE”, “REC QUALITY” and “AUDIO REC” settings can be specified for each Block (Cameras 1 - 4, Cameras 5 - 8, Cameras 9 - 12, Cameras 13 - 16).

WEEKLY TIMER									
START	END	CAM1-4	CAM5-8	CAM9-12	CAM13-16	EXEC			
SUN	**	**	**	**	**	**	**	**	**
MON	**	**	**	**	**	**	**	**	**
TUE	08 00 30	17 00	25 NA	2.5 N	1/2B	**	**	**	**
WED	**	**	**	**	**	**	**	**	**
THU	**	**	**	**	**	**	**	**	**
FRI	**	**	**	**	**	**	**	**	**
SAT	**	**	**	**	**	**	**	**	**
DAY	**	**	**	**	**	**	**	**	**
<=: RETURN [CANCEL]: CANCEL									

12.5 H A
 “FRAME RATE” “AUDIO REC”: ON
 “REC QUALITY”

- During “DAY” setting, ending time switches automatically to the following day if the ending time set is earlier than the starting time.
- When an invalid timer has been set, this invalid setting will be automatically deleted upon exiting the Timer screen. In this case, the “DELETE INVALID TIMER SETTING” message will be displayed on the screen. To clear this message, press the [CANCEL] button.

Caution

- Pay attention when changing the day of the week at the final line in Step 8. Other record program settings for which “DAY” has been selected will also be altered.
- When all the settings for cameras in a block (CAMERA 1 ~ CAMERA 4 / CAMERA 5 ~ CAMERA 8 / CAMERA 9 ~ CAMERA 12 / CAMERA 13 ~ CAMERA 16) under the “REC MODE” Menu (Page 24) are set to “OFF”, Program Timer Recording will not be activated for that block.

6. Press [▶] and turn the jog dial to set “FRAME RATE”, “REC QUALITY” and “AUDIO REC”

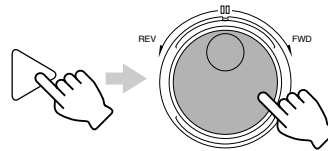

WEEKLY TIMER									
START	END	CAM1-4	CAM5-8	CAM9-12	CAM13-16	EXEC			
DAY	09 30	**	22 30	12.5 HA	25 NA	15 HA	15 HA	15 HA	WLY
MON	**	**	**	**	**	**	**	**	**
TUE	**	**	**	**	**	**	**	**	**
WED	**	**	**	**	**	**	**	**	**
THU	**	**	**	**	**	**	**	**	**
FRI	**	**	**	**	**	**	**	**	**
SAT	**	**	**	**	**	**	**	**	**
DAY	**	**	**	**	**	**	**	**	**
<=: RETURN [CANCEL]: CANCEL									

7. Press [▶] to move cursor to the “EXEC” column, and turn the jog dial to select “ON”

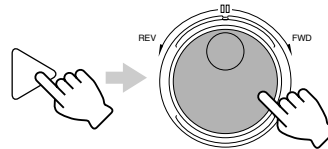

WEEKLY TIMER									
START	END	CAM1-4	CAM5-8	CAM9-12	CAM13-16	EXEC			
DAY	09 30	**	22 30	12.5 HA	25 NA	2.5 N	1/2B	ON	**
MON	**	**	**	**	**	**	**	**	**
TUE	**	**	**	**	**	**	**	**	**
WED	**	**	**	**	**	**	**	**	**
THU	**	**	**	**	**	**	**	**	**
FRI	**	**	**	**	**	**	**	**	**
SAT	**	**	**	**	**	**	**	**	**
DAY	**	**	**	**	**	**	**	**	**
<=: RETURN [CANCEL]: CANCEL									

8. Press [▽] to move the cursor to the final line

- Use [▶] and the jog dial to select the day of the week to execute recording. Select “--” for days of the week for which recording is not to be executed.

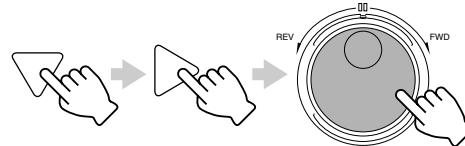

WEEKLY TIMER									
START	END	CAM1-4	CAM5-8	CAM9-12	CAM13-16	EXEC			
DAY	09 30	**	22 30	12.5 HA	25 NA	2.5 N	1/2B	ON	**
MON	**	**	**	**	**	**	**	**	**
TUE	**	**	**	**	**	**	**	**	**
WED	**	**	**	**	**	**	**	**	**
THU	**	**	**	**	**	**	**	**	**
FRI	**	**	**	**	**	**	**	**	**
SAT	**	**	**	**	**	**	**	**	**
DAY	**	**	**	**	**	**	**	**	**
<=: RETURN [CANCEL]: CANCEL									

9. Move the cursor to “<=: RETURN” using [▽] and press [◀]

- This displays the “PROGRAM TIMER” Menu screen.



WEEKLY TIMER									
START	END	CAM1-4	CAM5-8	CAM9-12	CAM13-16	EXEC			
DAY	09 30	**	22 30	12.5 HA	25 NA	2.5 N	1/2B	ON	**
MON	**	**	**	**	**	**	**	**	**
TUE	**	**	**	**	**	**	**	**	**
WED	**	**	**	**	**	**	**	**	**
THU	**	**	**	**	**	**	**	**	**
FRI	**	**	**	**	**	**	**	**	**
SAT	**	**	**	**	**	**	**	**	**
DAY	**	**	**	**	**	**	**	**	**
<=: RETURN [CANCEL]: CANCEL									

10. Press [MENU] to return to the normal screen, and press [TIMER]

- The Timer indicator on the front display lights up.
- The Weekly Timer Program No. on the front display lights up. (The number of the line for which timer recording has been set will light up)

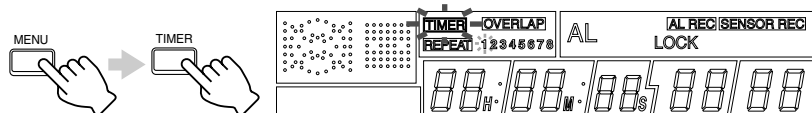

Routine Uses (continued)

Record Programming Using the Program Timer

Date Timer

For executing the recording of a program on different dates.

<Example>

Execute recording from 8:00 a.m. ~ 11:00 p.m. on 1 October and 10 October.

■ Recording Mode

- **Cameras 1 - 4**
 - “FRAME RATE” : “8.3 IPS”
 - “REC QUALITY” : “H”
 - “AUDIO REC” : “A” (ON)
- **Cameras 5 - 8**
 - Do not record
- **Cameras 9 - 12**
 - “FRAME RATE” : “4.2 IPS”
 - “REC QUALITY” : “B”
 - “AUDIO REC” : – (OFF)
- **Cameras 13 - 16**
 - Do not record

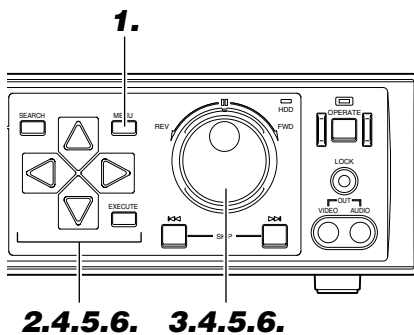

1. Press the [MENU] button

- Follow procedures in ‘Changing Menu Settings’ on page 22 to display the “PROGRAM TIMER” Menu and the “DATE TIMER” Menu screens.

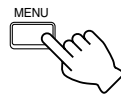

DATE TIMER						
START	END	CAM1-4	CAM5-8	CAM9-12	CAM13-16	EXEC
1.	---	---	---	---	---	---
2.	---	---	---	---	---	---
3.	---	---	---	---	---	---
4.	---	---	---	---	---	---
5.	---	---	---	---	---	---
6.	---	---	---	---	---	---
7.	---	---	---	---	---	---
8.	---	---	---	---	---	---
<=: RETURN						
[CANCEL]:CANCEL						

2. Press [▽] to select the line for which program is to be set

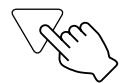

- For example, move the cursor to select the first line. (Program can be set for any line.)

3. Turn the jog dial to set the starting Day column to “1”

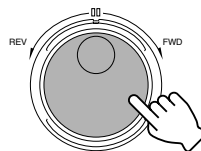

DATE TIMER						
START	END	CAM1-4	CAM5-8	CAM9-12	CAM13-16	EXEC
1.	1-	---	---	---	---	---
2.	---	---	---	---	---	---
3.	---	---	---	---	---	---
4.	---	---	---	---	---	---
5.	---	---	---	---	---	---
6.	---	---	---	---	---	---
7.	---	---	---	---	---	---
8.	---	---	---	---	---	---
<=: RETURN						
[CANCEL]:CANCEL						

4. Press [▶] to move cursor to the starting Month position, and turn the jog dial to select “10”

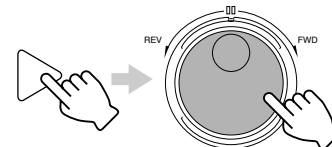

DATE TIMER						
START	END	CAM1-4	CAM5-8	CAM9-12	CAM13-16	EXEC
1.	01-	---	---	---	---	---
2.	---	---	---	---	---	---
3.	---	---	---	---	---	---
4.	---	---	---	---	---	---
5.	---	---	---	---	---	---
6.	---	---	---	---	---	---
7.	---	---	---	---	---	---
8.	---	---	---	---	---	---
<=: RETURN						
[CANCEL]:CANCEL						

5. Perform setting for other Day and Month items accordingly

- Repeat Steps 2 ~ 4 to set the Day and Month.

DATE TIMER						
START	END	CAM1-4	CAM5-8	CAM9-12	CAM13-16	EXEC
1.	01-10	---	---	---	---	---
2.	10-	---	---	---	---	---
3.	---	---	---	---	---	---
4.	---	---	---	---	---	---
5.	---	---	---	---	---	---
6.	---	---	---	---	---	---
7.	---	---	---	---	---	---
8.	---	---	---	---	---	---
<=: RETURN						
[CANCEL]:CANCEL						

Caution

- Refer to the notes related to Summer Time. (Page 116)

6. Press [△] to move cursor to the Hour position under the “START” column, and turn the jog dial to select “08”

- To set the minute value of the starting time, press [▶] to move cursor to the Minute position and adjust by turning the jog dial.

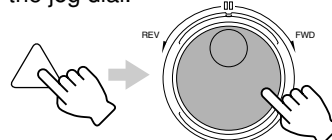

DATE TIMER						
START	END	CAM1-4	CAM5-8	CAM9-12	CAM13-16	EXEC
1.	01-10	---	---	---	---	---
2.	10-10	---	---	---	---	---
3.	---	---	---	---	---	---
4.	---	---	---	---	---	---
5.	---	---	---	---	---	---
6.	---	---	---	---	---	---
7.	---	---	---	---	---	---
8.	---	---	---	---	---	---
<=: RETURN						
[CANCEL]:CANCEL						

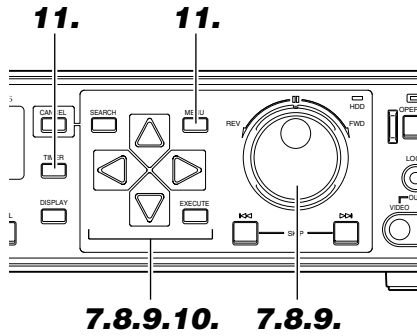

7. Press [▶] to move cursor to the *Hour* position under the “END” column, and turn the jog dial to select “23”

- To set the minute value of the ending time, press [▶] to move cursor to the *Minute* position and adjust by turning the jog dial.

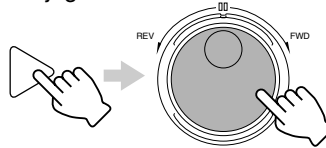

DATE TIMER						
START	END	CAM1-4	CAM5-8	CAM9-12	CAM13-16	EXEC
08 00	23 00	8.3HA	4.2B	ON	ON	ON
1.	01 - 10	9.	---	---	---	---
2.	10 - 10	10.	---	---	---	---
3.	---	11.	---	---	---	---
4.	---	12.	---	---	---	---
5.	---	13.	---	---	---	---
6.	---	14.	---	---	---	---
7.	---	15.	---	---	---	---
8.	---	16.	---	---	---	---
<=: RETURN						
[CANCEL]:CANCEL						

Notes

- The “FRAME RATE”, “REC QUALITY” and “AUDIO REC” settings of Block 1 (Cameras 1 - 4) will be automatically copied to the remaining blocks. To make alterations, do so by turning the jog dial.
- In the case of camera blocks for which recording is not to be executed, press the [CANCEL] button to clear the settings.
- Maximum duration of nonstop recording will last for less than 24 hours.
- “FRAME RATE”, “REC QUALITY” and “AUDIO REC” settings can be specified for each Block (Cameras 1 - 4, Cameras 5 - 8, Cameras 9 - 12, Cameras 13 - 16).

DATE TIMER						
START	END	CAM1-4	CAM5-8	CAM9-12	CAM13-16	EXEC
08 00	23 00	8.3HA	4.2B	ON	ON	ON
1.	01 - 10	9.	---	---	---	---
2.	10 - 10	10.	---	---	---	---
3.	---	11.	---	---	---	---
4.	---	12.	---	---	---	---
5.	---	13.	---	---	---	---
6.	---	14.	---	---	---	---
7.	---	15.	---	---	---	---
8.	---	16.	---	---	---	---
<=: RETURN						
[CANCEL]:CANCEL						

8.3 H A
 “FRAME RATE” “AUDIO REC”: ON
 “REC QUALITY”

- Ending time switches automatically to the following day if the ending time set is earlier than the starting time.
- When an invalid timer has been set, this invalid setting will be automatically deleted upon exiting the Timer screen. In this case, the “DELETE INVALID TIMER SETTING” message will be displayed on the screen. To clear this message, press the [CANCEL] button.

Caution

- When all the settings for cameras in a block (CAMERA 1 ~ CAMERA 4 / CAMERA 5 ~ CAMERA 8 / CAMERA 9 ~ CAMERA 12 / CAMERA 13 ~ CAMERA 16) under the “REC MODE” Menu (Page 24) are set to “OFF”, Program Timer Recording will not be activated for that block.

8. Press [▶] and turn the jog dial to set “FRAME RATE”, “REC QUALITY” and “AUDIO REC”

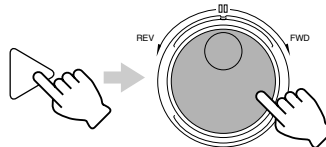

DATE TIMER						
START	END	CAM1-4	CAM5-8	CAM9-12	CAM13-16	EXEC
08 00	23 00	8.3HA	4.2B	ON	ON	ON
1.	01 - 10	9.	---	---	---	---
2.	10 - 10	10.	---	---	---	---
3.	---	11.	---	---	---	---
4.	---	12.	---	---	---	---
5.	---	13.	---	---	---	---
6.	---	14.	---	---	---	---
7.	---	15.	---	---	---	---
8.	---	16.	---	---	---	---
<=: RETURN						
[CANCEL]:CANCEL						

9. Press [▶] and turn the jog dial to select “ON” under the “EXEC” column

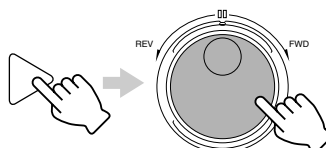

DATE TIMER						
START	END	CAM1-4	CAM5-8	CAM9-12	CAM13-16	EXEC
08 00	23 00	8.3HA	4.2B	ON	ON	ON
1.	01 - 10	9.	---	---	---	---
2.	10 - 10	10.	---	---	---	---
3.	---	11.	---	---	---	---
4.	---	12.	---	---	---	---
5.	---	13.	---	---	---	---
6.	---	14.	---	---	---	---
7.	---	15.	---	---	---	---
8.	---	16.	---	---	---	---
<=: RETURN						
[CANCEL]:CANCEL						

10. Move the cursor to “<=: RETURN” using [▽] and press [◀]



DATE TIMER						
START	END	CAM1-4	CAM5-8	CAM9-12	CAM13-16	EXEC
08 00	23 00	8.3HA	4.2B	ON	ON	ON
1.	01 - 10	9.	---	---	---	---
2.	10 - 10	10.	---	---	---	---
3.	---	11.	---	---	---	---
4.	---	12.	---	---	---	---
5.	---	13.	---	---	---	---
6.	---	14.	---	---	---	---
7.	---	15.	---	---	---	---
8.	---	16.	---	---	---	---
<=: RETURN						
[CANCEL]:CANCEL						

11. Press [MENU] to return to the normal screen, and press [TIMER]

- The Timer indicator on the front display lights up.

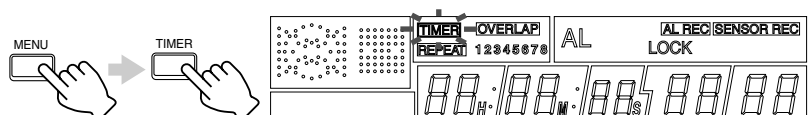

Routine Uses (continued)

Record Programming Using the Program Timer

Canceling a Record Program

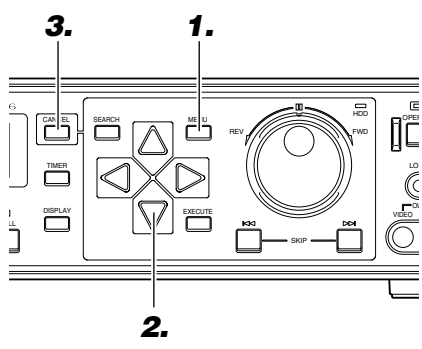

1. Press the [MENU] button

- Follow procedures in 'Changing Menu Settings' on page 22 to display the "PROGRAM TIMER" Menu and the "WEEKLY TIMER" Menu screens.

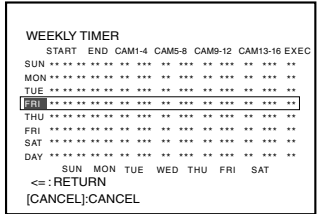
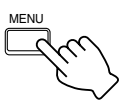

2. Press [▽] to select the record program to delete

- For example, delete the fourth line of the record program.

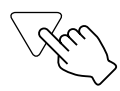

3. Press the [CANCEL] button

- The selected record program will be deleted.

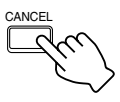

Notes

- Move the cursor away from the "CAM" 1-4 / 5-8 / 9-12 / 13-16 items and press the [CANCEL] button to clear all settings for a particular day.
- If the [CANCEL] button is pressed with the cursor inside any of the "CAM" 1-4 / 5-8 / 9-12 / 13-16 columns, only that camera block will be cleared.

Changing a Record Program

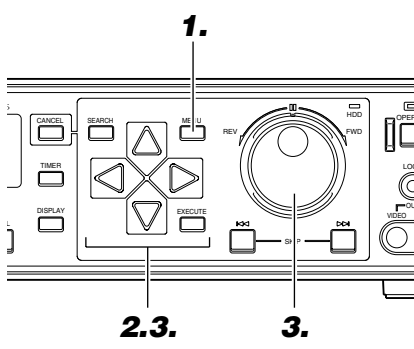

1. Press the [MENU] button

- Follow procedures in 'Changing Menu Settings' on page 22 to display the "PROGRAM TIMER" Menu and the "WEEKLY TIMER" Menu screens.

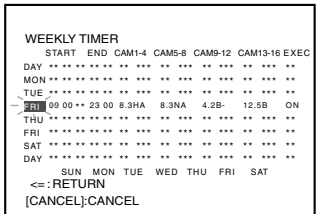
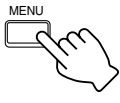

2. Press [▽] to select the record program to alter

- For example, alter the fourth line of the record program.

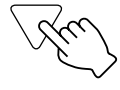

3. Press [▶] to select the item and alter by turning the jog dial

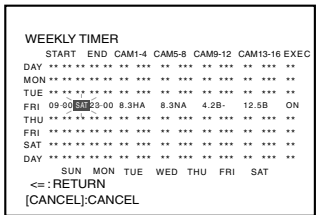
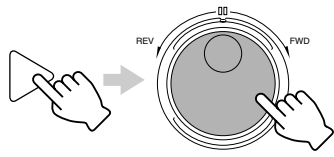

Useful Features

Hard Disk Maintenance

When power failure occurs while in the Recording mode or Sensor Record Standby mode, or when failure occurs in the recorded data of the hard disk, recording/playback may not function properly. To repair the hard disk, two types of scan disk functions are available on VR-716:

- **Auto Scan Disk**

Scans the hard disk automatically upon turning on the power.

- **Manual Scan Disk**

Performs manual scanning of the hard disk. Perform Manual Scan Disk regularly when the “AUTO SCAN DISK” item in the menu is set to “OFF” or when the power of the equipment remains on for extensive periods of time.

Scanning Hard Disk Data (“AUTO SCAN DISK”)

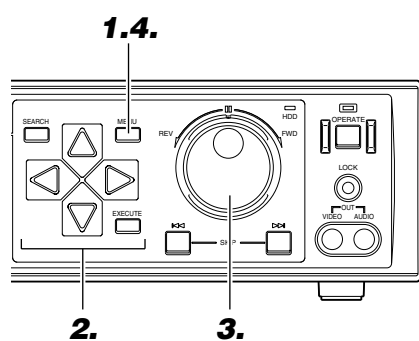

1. Press the [MENU] button

- Follow procedures in ‘Changing Menu Settings’ on page 22 to display the “DISK UTILITY/MAINTENANCE” Menu and the “DISK UTILITY” screen.

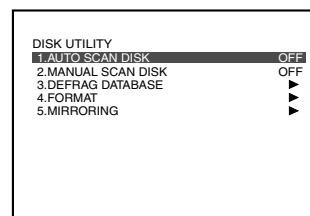
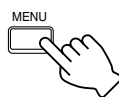

2. Press [▽] to select the “AUTO SCAN DISK” item

- Move the cursor to select.



3. Turn the jog dial to select “ON”

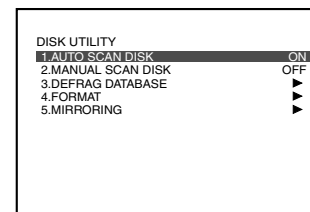
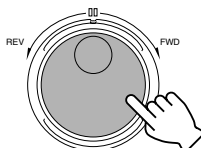

Notes

- To cancel the Auto Scan Disk operation, press the [CANCEL] button.
- Scan the hard disk once a month if recording is continuously executed.

Caution

- Scanning may take a longer time if the data volume of recorded events are heavy or if there is a large number of events. (Approx. a few hours)
- Recording, playback and search are not possible when Auto Scan Disk is executed.

4. Press [MENU] to end setting

- The display returns to the normal screen.
- Scanning will be executed when the power is turned on.

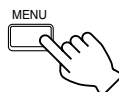

Useful Features (continued)

Hard Disk Maintenance

Scanning Hard Disk Data (“MANUAL SCAN DISK”)

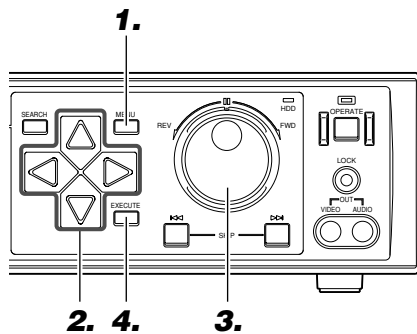

1. Press the [MENU] button

- Follow procedures in 'Changing Menu Settings' on page 22 to display the “DISK UTILITY/MAINTENANCE” Menu and the “DISK UTILITY” screen.

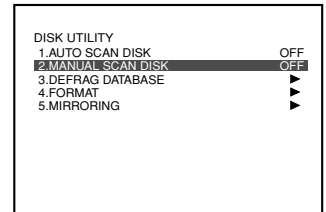
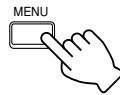

2. Press [▽] to select the “MANUAL SCAN DISK” item

- Move the cursor to select.



3. Turn the jog dial to select “ON”

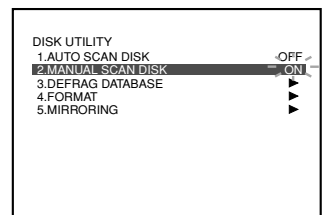
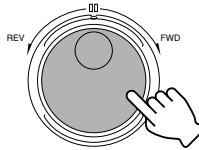

4. Press the [EXECUTE] button

- This starts the scanning.



Screen Display when in the Disk Scanning Mode

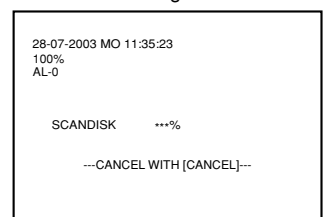

Notes

- To cancel the Manual Scan Disk operation, press the [CANCEL] button.
- Scan the hard disk once a month if recording is continuously executed.

Caution

- Scanning may take a longer time if the data volume of recorded events are heavy or if there is a large number of events. (Approx. a few hours)
- Recording, playback and search are not possible when Manual Scan Disk is executed.

Defrag

When alarm or sensor recording is performed repeatedly with Repeat Recording set to "ON", data in the hard disk may become fragmented. Continued use of such data may cause files to split up and recorded into free space, thereby giving rise to fragmentation or decay of data and subsequently slows down the speed extremely during hard disk search. This is where the "DEFRAG DATABASE" feature comes into play in the maintenance of the hard disk.

It is also recommended to "FORMAT" (Initialize) the hard disk on a regular basis to avoid data fragmentation. When there is insufficient hard disk space, create a backup data and format the disk to create space for the recorded data.

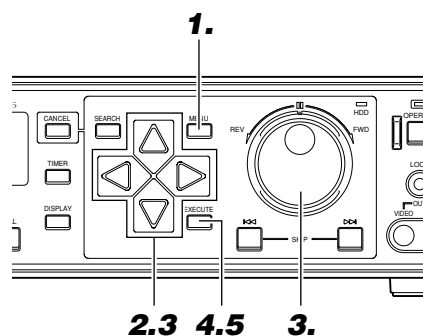

1. Press the [MENU] button

- Follow procedures in 'Changing Menu Settings' on page 22 to display the "DISK UTILITY/MAINTENANCE" Menu and the "DISK UTILITY" screen.

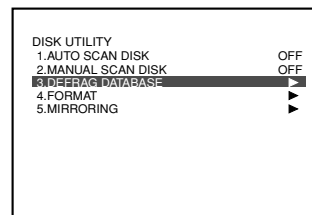
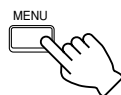

2. Select the "DEFRAG DATABASE" item using [▽] and press [▶]

- This displays the "DEFRAG DATABASE" Menu.



3. Select "DEFRAG" using [▽], press [▶] and turn the jog dial to select "YES".

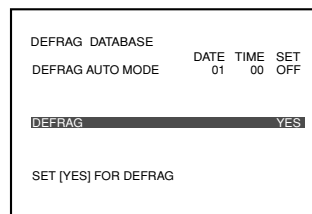
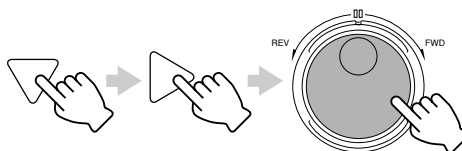

4. Press the [EXECUTE] button

- This displays the "DEFRAG CONFIRMATION" Screen.

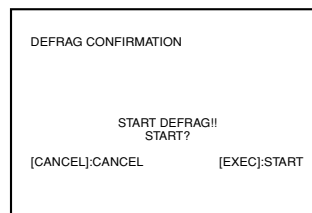
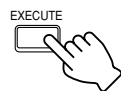

5. Press the [EXECUTE] button again

- Defrag starts. Upon completion, a "COMPLETED" message will be displayed on the screen.

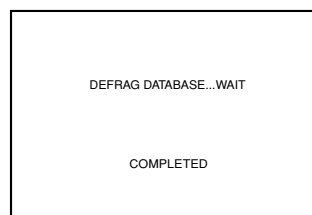

Notes

- Perform defrag if search operation takes more than 30 seconds.
- Disabled when in the Recording mode. (Not including automatic execution.)
- To enable automatic execution, select the "DEFRAG AUTO MODE" item, specify the date and time and set to "ON". Defrag will run automatically on the specified date/time.

Caution

- It will interrupt the recording and perform defrag if the time of the automatic execution is reached during recording. Recording will be resumed automatically after defrag has been completed.

Useful Features (continued)

Initializing the Hard Disk (“FORMAT”)

Recording may fail if there is insufficient space on the hard disk. In this case, format the hard disk to create space.

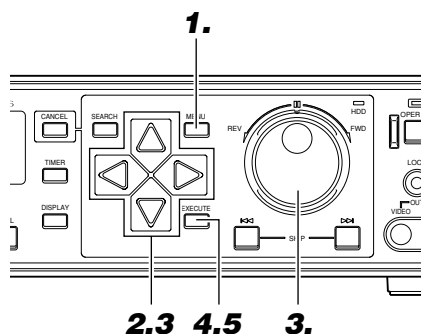

1. Press the [MENU] button

- Follow procedures in ‘Changing Menu Settings’ on page 22 to display the “DISK UTILITY/MAINTENANCE” Menu and the “DISK UTILITY” screen.

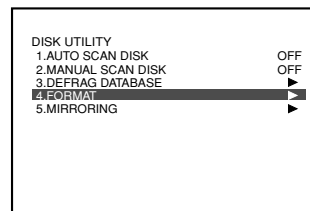
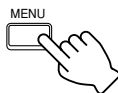

2. Select the “FORMAT” item using [▾] and press [▶]

- This displays the “FORMAT” screen.



3. Use [▲ / ▼] to select the hard disk to format, and turn the jog dial to select “YES”

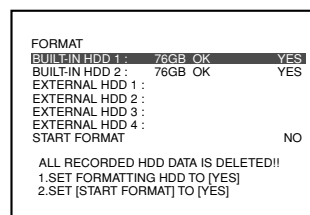
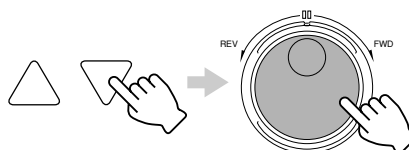

Note

- The hard disk capacity displayed on the screen is calculated based on 1 GB = (1024)³ Bytes. Therefore it is displayed as lower than the actual capacity.

4. Select “START FORMAT”, turn the jog dial to select “YES” and press the [EXECUTE] button.

- This displays the “FORMAT CONFIRMATION” Screen.

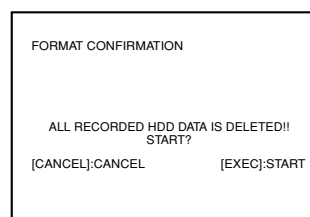
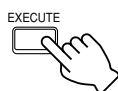

Caution

- All recorded events will be deleted upon formatting. Ensure to create a backup for important event records.
- At the screen upon completion of “FORMAT”, never unplug the power cord.

5. Press the [EXECUTE] button again

- Formatting starts. Upon completion, the “FORMAT SUCCEEDED” screen will be displayed.
- Press [OPERATE] button to start.

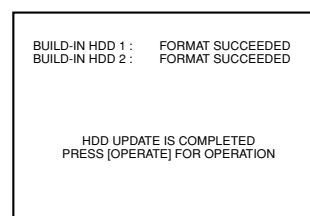
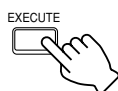

Hard Disk Mirroring

Mirroring refers to recording the same data in the 2 built-in hard disks. In this way, recorded data can be secured even if data in one of the hard disks is damaged.

Mirroring Setting

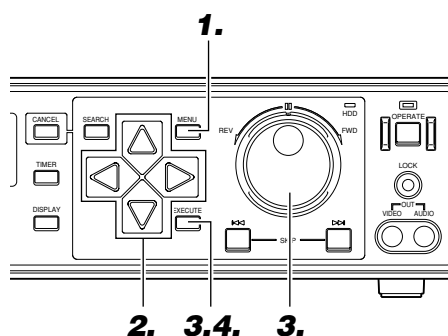

1. Press the [MENU] button

- Follow procedures in 'Changing Menu Settings' on page 22 to display the "DISK UTILITY/MAINTENANCE" Menu and the "DISK UTILITY" screen.

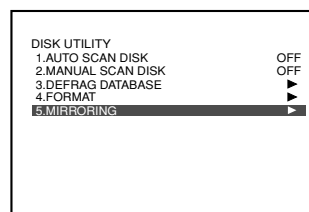
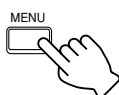

2. Select the "MIRRORING" item using [▽] and press [▶]

- This displays the "MIRRORING" Menu screen.

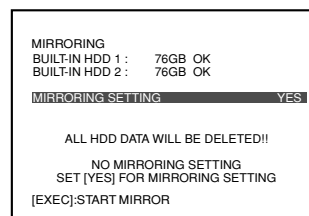

3. Turn the jog dial to select "YES" and press [EXECUTE] button

- This displays the "MIRRORING CONFIRMATION" screen.

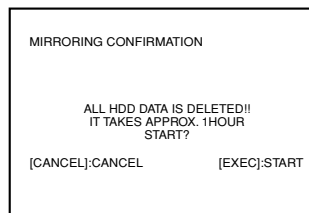
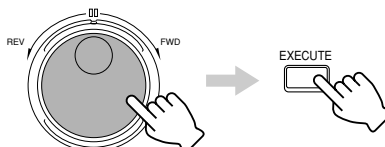

4. Press the [EXECUTE] button again

- Setting takes approximately 1 hour, upon which mirroring setting will be completed.
- Upon completion, the "MIRRORING SETTING SUCCEEDED" screen will be displayed.
- Press [OPERATE] button to start.

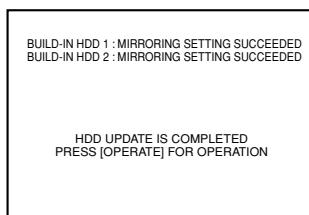
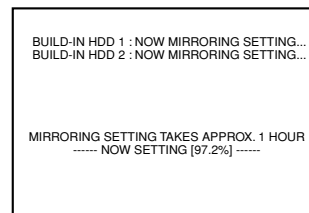

Notes

- Mirroring settings can be undone in the Mirroring mode. (Page 60)
- Recording and playback are not possible when performing mirroring setting.
- The hard disk capacity displayed on the screen is calculated based on 1 GB = (1024)³ Bytes. Therefore it is displayed as lower than the actual capacity.

Caution

- When mirroring is set, recordable space in the hard disk will reduce by half. Pay attention when setting the recording duration.
- Mirroring can only be set for built-in hard disks. Mirroring at external hard disk drives are not possible.
- There is no guarantee that data will not be damaged when mirroring is set.
- When mirroring settings are activated, events recorded in the built-in as well as external hard disks will be deleted. Ensure to create a backup for important event records.
- When mirroring settings are activated, playback speed may slow down or image and sound may be out of sync, depending on the record settings and operational state. This does not affect the recording operation.

Useful Features (continued)

Hard Disk Mirroring (continued)

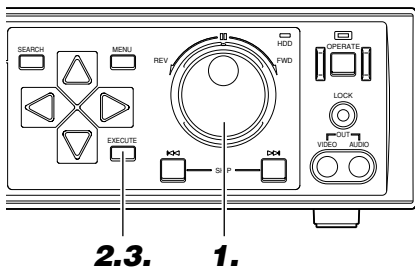

Undo Mirroring

1. Turn the jog dial to select “NO” during mirroring setting.

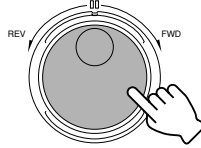

2. Press the [EXECUTE] button

- This displays the “MIRRORING CONFIRMATION” screen.

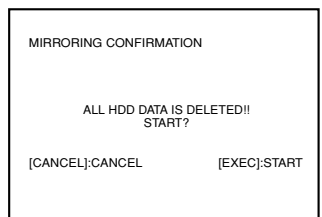
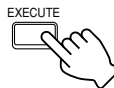

3. Press the [EXECUTE] button again

- Cancels the mirroring setting operation and exits the Mirroring mode.
- Upon completion, the “MIRRORING CANCELLATION SUCCEEDED” screen will be displayed.
- Press [OPERATE] button to start.

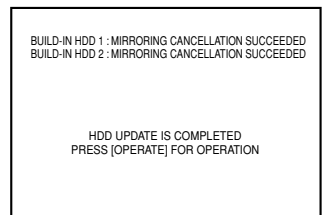
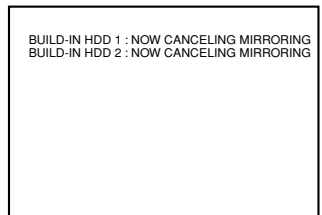
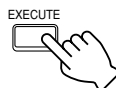

Notes

- Recording and playback are not possible when undoing mirroring.
- The hard disk capacity displayed on the screen is calculated based on 1 GB = (1024)³ Bytes. Therefore it is displayed as lower than the actual capacity.

Caution

- When mirroring is undone, events recorded in the built-in as well as external hard disks will be deleted. Ensure to create a backup for important event records.

To view the list of Power Outage Recovery Records

Viewing of the list of date and time at which power failure is restored is possible.

1.

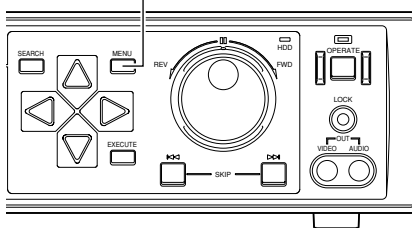

1. Press the [MENU] button

- Follow procedures in ‘Changing Menu Settings’ on page 22 to display the “DISK UTILITY/MAINTENANCE” Menu and the “MAINTENANCE” screen.
- This displays the “POWER OUTAGE TIME LIST”.

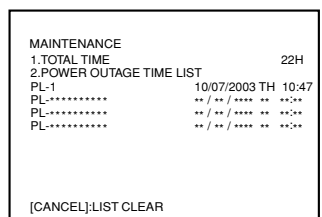

Series Recording Using 2 or More VR-716 Recorders

Recording using 2 or more VR-716 recorders is possible. Once the first VR-716 is full, recording automatically starts at the second VR-716.

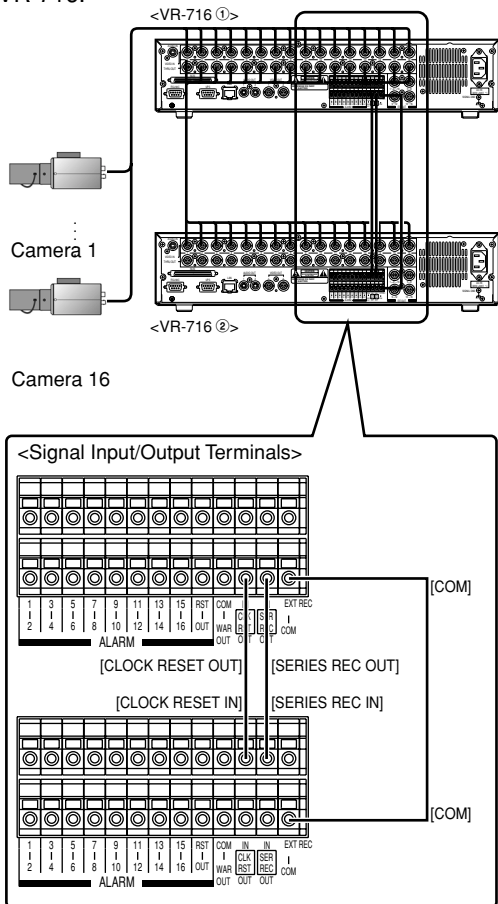

Connection

<Connection of the Signal Input/Output Terminals>

- Connect the [SERIES REC OUT] terminal at the rear panel of the first VR-716 to the [SERIES REC IN] terminal of the second.
- Connect the [CLOCK RESET OUT] terminal of the first VR-716 to the [CLOCK RESET IN] terminal of the second.
- Connect the [COM] terminal of the first VR-716 to the same terminal at the second.

<Connection between the 2 VR-716 Recorders>

- Connect the [THRU OUT] terminals 1 - 16 of the first VR-716 to the [VIDEO IN] terminals 1 - 16 of the second VR-716 accordingly.

Setting

- Specify the same settings for both recorders in the “REC MODE” Menu (☞ Page 24).
- In the “OPERATION” Menu, specify a value other than “NORMAL REC” for the “RECOVERY REC” item.
- In the “OPERATION” Menu (☞ Page 25) of the first VR-716, set “REPEAT REC” to “OFF”.
- Set the “SERIES REC” item in the “EXT REC” Menu (☞ Page 25) to “ON” for both recorders.

Notes

- When the [CLOCK RESET OUT/IN] terminals are connected, the clock in the 2 or more VR-716 recorders will be synchronized twice a day at 12:00 am and 12:00pm.
- Turn off the power of the equipment before connecting.
- Recording at the second VR-716 can only be stopped by using the [STOP] button on it.
- Recording will not start upon input of signals when the [OPERATE] button is in the OFF mode.
- Recording will not start when in the Program Timer Standby mode.
- When the power of the first VR-716 is cut off, the second VR-716 starts recording automatically.

Activation of Recording Via External Signals

While in the Stop mode, recording starts when the [EXT REC IN] terminal at the rear panel receives input signals from external devices.

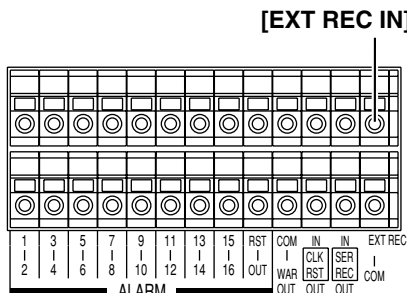

Setting

1. Set the “EXT REC MODE” item in the “EXT REC” Menu to “TRIGGER” or “MANUAL”.

Notes

- When this is set to “MANUAL”, recording is executed only while input signals are received.
- When this is set to “TRIGGER”, recording will continue between the interval when input signals are received until after execution of the Stop operation. Recording can only be stopped by using the [STOP] button on VR-716. Recording cannot be stopped using an external device.
- Recording will not start upon input of signals when the [OPERATE] button is in the OFF mode.
- Recording will not start when in the Program Timer Standby mode.

Useful Features (continued)

External Hard Disk Drives

VR-716 allows connection of up to 4 external hard disk drives in addition to the 2 built-in hard disks. Follow the procedure below to alter the connection setup of the hard disk. There are 3 ways of altering connection setup, namely "NEW", "CHANGE" and "DISCONNECT".

<Rear Panel of VR-716>

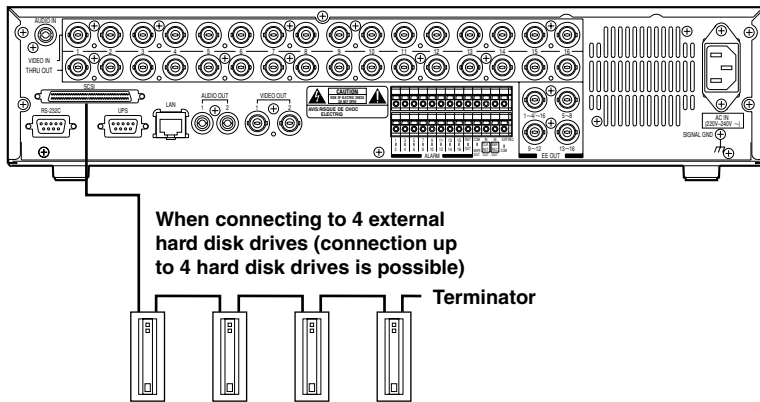

※ When connecting to multiple hard disk drives

- Set a separate SCSI ID No. for each hard disk and ensure that there are no duplicate values.
- Connect the last hard disk drive in the series to the terminator.
(Refer to the instruction manual of the hard disk drive to be connected for procedure on setting the SCSI ID No. as well as termination.)

<Alteration of Connection Setup>

- "NEW" : Connect to a new hard disk drive.
- "CHANGE" : Replace the hard disk drive currently connected with another hard disk.
- "DISCONNECT" : Disconnect the hard disk drive currently connected. Once a hard disk drive is disconnected, images recorded on the hard disk cannot be viewed even when it is reconnected.

Notes

- For the external hard disk and cable that can be connected, consult your nearest JVC dealer.
- The external hard disk drive will not function properly if its power is turned on after turning on VR-716.
- Turn off the power of VR-716 before turning off the power of external hard disk.
- When turning off the power of the external hard disk in the OPERATE OFF status of this unit, disconnect this unit from the wall outlet together.

Caution

- Recording will not be performed properly and this unit will restart automatically if the power supply of external hard disk is turned off during recording.
Do not turn off the power supply of external hard disk during operation.

<SCSI Standards on Expansion >

Interface	Ultra Wide SCSI
Connector	Half Pitch D-sub 68 Pin
Maximum Transfer Rate	20 MB/s
SCSI ID	Use values between 0 ~ 3 (4 and above cannot be used)

Notes

- Maximum transfer rate is not guaranteed.
- Consult the outlet from which this equipment is purchased on the types of HDD and cable that can be connected.

1. Turn OFF the power

- Turn off the power by following the procedure on 'Turning OFF the Power' in 'Turning ON/OFF the Power' on page 15.
- External hard disk drive cannot be detected even if it is connected with the power turned off. Connect only after unplugging the power cord.

2. Connect the external hard disk drive and turn ON the power

- Turn on the power of the external disk drive before doing so for VR-716.

3. Turn ON the power of VR-716

- Turn on the power by following the procedure on 'Turning ON the Power' in 'Turning ON/OFF the Power' on page 15.
- The "HDD RECONFIGURING" screen will be displayed.

HDD RECONFIGURING
EXTERNAL HDD 4: 115GB NEW

HDD CONFIGURATION CHANGED
PUSH [EXEC] FOR ABOVE HDD APPLY
PUSH [CANCEL] TO QUIT
(ALL RECONFIGURING DATA IS DELETED!)

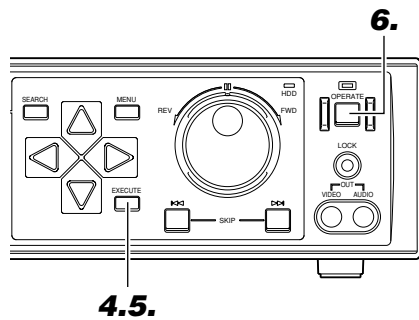

4. Press the [EXECUTE] button

- This displays the “CONFIRM HDD RECONFIGURING” Screen.

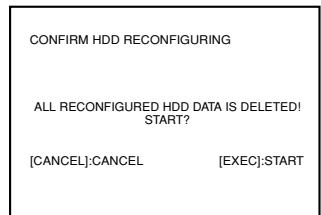
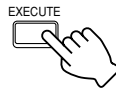

Notes

- If the “HDD RECONFIGURING” screen is not displayed upon turning on the power again, this means the connection is faulty. Turn off the power of VR-716 and the external hard disk drives and check if the cables, terminator and power supply are properly connected.
- Press the [CANCEL] button when the HDD Reconfiguration screen is displayed to terminate the process. Upon terminating, turn off the power of VR-716.
- Disconnection instead of formatting will be executed when “DISCONNECT” is selected for the alteration of connection setup. The “NOW DISCONNECTING...” → “DISCONNECTING SUCCEEDED” messages will be displayed on the screen.
- Formatting time required for each external hard disk drive (120 GB) is about 30 seconds.
- Recording and playback are not possible when altering connection setup.
- The hard disk capacity displayed on the screen is calculated based on 1 GB = (1024)³ Bytes. Therefore it is displayed as lower than the actual capacity.

Caution

- At the screen upon completion of “FORMAT”, never unplug the power cord.

5. Press the [EXECUTE] button again

- This starts the formatting of the external hard disk drive.
- Upon completion, the “FORMAT SUCCEEDED” screen will be displayed.

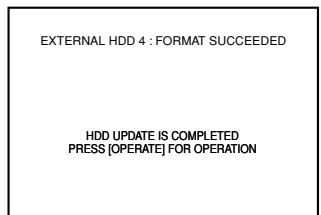
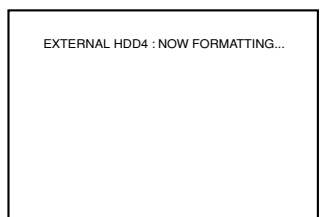

6. Press the [OPERATE] button

- The hard disk drives are now usable.

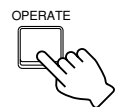

Hard Disk Recovery Feature

Note

- The following operations are not possible when error [E-01] is displayed:
 - “TIME ZONE SETTING”
 - “DEFRAG DATABASE”
 - “FORMAT”
 - “MIRRORING”
 - “DVD-RAM COPY”

This unit is incorporated with automatic recovery feature. When there is failure on the hard disk, it will restart and recover automatically. Upon restart, recording will continue with the remaining hard disk after the hard disk which failure occurred had been automatically disconnected. Recording is disabled during restart. Error code [E-01] will be displayed on the front display after automatic restart.

To return to the normal display from error code display, turn [OPERATE] to off once and then turn [OPERATE] to on again.

Automatic recovery is not possible in the case of severe failure where it cannot be rebooted.

Useful Features (continued)

Copying to DVD-RAM

Copy of data stored in VR-716 to DVD-RAM is possible when a DVD-RAM drive is connected to it.

<VR-716>

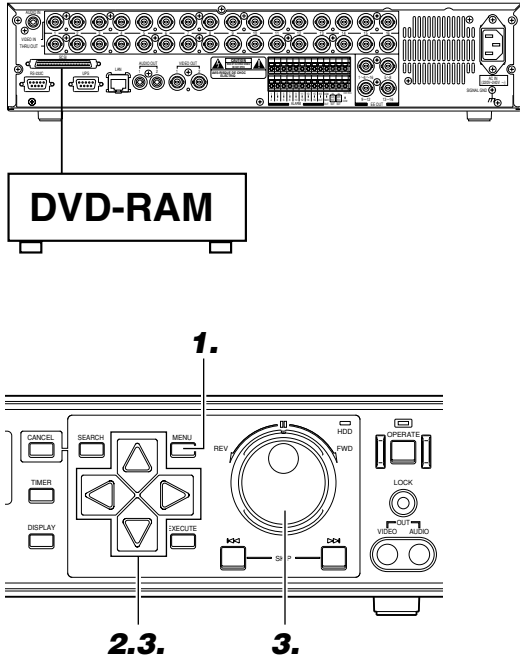

Connection

Connect the DVD-RAM drive to the [SCSI] terminal on the rear panel of VR-716.

DVD-RAM FORMAT

- Before copying to the DVD-RAM, execute “6.DVD-RAM FORMAT” under “DISK UTILITY” in “DISK UTILITY/MAINTENANCE”.
- Execute DVD-RAM FORMAT using VR-716.
- DVD-RAM will be formatted by FAT32.
- It will return to “DISK UTILITY/MAINTENANCE” menu automatically after the “DVD-RAM FORMAT” is completed.

Caution

- All the data in DVD-RAM will be deleted if “DVD-RAM FORMAT” is executed.

Copying to DVD-RAM

1. Press the [MENU] button

- Follow procedures in ‘Changing Menu Settings’ on page 22 to display the “DISK UTILITY/MAINTENANCE” Menu and the “DISK UTILITY” screen.
- Stop the recording if it is in operation.

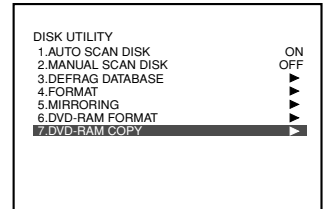
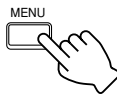

2. Select the “DVD-RAM COPY” item using [▽] and press [▶]

- The “DVD-RAM COPY” screen will be displayed.

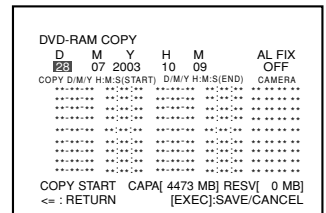

3. Turn the jog dial to select a “D” (Day) value

- Use [▶] and the jog dial to set the starting day, month, year, hour, minute and second values of the data to copy.
- To display only alarm/sensor data, set “AL FIX” to “ON”.

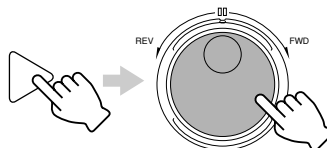

Notes

- When a DVD-RAM drive is not connected, the following items will not be displayed on the “DISK UTILITY” Menu:
Item “6. DVD-RAM FORMAT”
Item “7. DVD-RAM COPY”
- 2 or more DVD-RAM drives cannot be connected.
- Consult the outlet from which this equipment is purchased on the types of DVD-RAM drive and cable that can be connected.
- The number of devices including external hard disk to be connected to SCSI terminal should be 4 or less.
- When connecting external hard disk simultaneously, connect the DVD-RAM drive to the nearest terminator.
- Set the SCSI ID of the DVD-RAM drive to 4.
- The order of D/M/Y will change in accordance with the “DATE DISPLAY” setting in the “ONSCREEN MODE” menu.
- Recording and playback on this unit are not possible during “DVD-RAM COPY”.
- Network connection is not possible during “DVD-RAM COPY”.

Caution

- Always leaves the power supply of DVD-RAM drive on. Malfunction will occur if power is turned off and when DVD-RAM is not inserted.

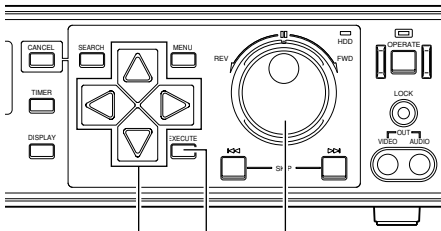

6.8. 4.5. 5.6.
7.8.
9.

Notes

- This cannot be executed if the data volume to be copied exceeds the space available.
- The data copied to the DVD-RAM may shift 2 seconds forward or backward from the specified location.
- Press the [SEARCH] button upon completion of DVD-RAM Copy. A file list containing the copied data on the DVD-RAM will be displayed.
 - The image data copied previously is also displayed in the list.
 - If the copied image data is the same as the previously copied data, it will be stored and displayed in the list separately with different names on the DVD-RAM.
 - The items of the list remain even if the image data is deleted via computer or others.
- When copying data which has been selected for copy (indicated by the [○] mark) in Step 5, the [○] mark will disappear and returns to the screen for setting the starting/ending time. Set the date/time again and execute.
- For the file name of image data, refer to the instruction manual of VR-716 PLAYER (Execute backup).
- Do not change the file name. The correct information may not be displayed during playback.

Caution

- At the screen upon completion of "DVD-RAM COPY", never unplug the power cord.
- Refer to the notes related to Summer Time. (Page 116)
- Take note of the following when setting the starting/ending time of DVD-RAM Copy:
 - Set a starting/ending time that is within the time range of the master data.
 - The starting time set shall precede the ending time.
 - Dates that do not correspond to the calendar cannot be specified.
 - File with "FRAME RATE" less than 25 copied to DVD-RAM may not be able to playback using the same method as viewing the backup file on the PC installed with bundled application [VR-716 Player].

4. Press the [EXECUTE] button

- The data list is displayed and cursor moves to the data closest to the specified starting day, month, year, hour, minute and second.
- Alarm/sensor data is displayed in yellow.



DVD-RAM COPY									
D	M	Y	H	M	AL	FIX			
28	07	2003	10	10	OFF	OFF			
COPY D/M/Y H:M:S(START) D/M/Y H:M:S(END) CAMERA									
○	28-07-03	06:30:16	28-07-03	06:30:16	13	14	15	16	
○	28-07-03	06:30:16	28-07-03	06:30:16	1				
○	28-07-03	06:30:16	28-07-03	06:30:16	5				
○	28-07-03	06:30:16	28-07-03	06:30:16	9				
○	28-07-03	06:30:14	28-07-03	06:30:14	1				
○	28-07-03	06:30:14	28-07-03	06:30:14	5				
○	28-07-03	06:30:13	28-07-03	06:30:13	9				
○	28-07-03	06:30:16	28-07-03	06:30:16	9				
COPY START CAPA[4473 MB] RESV[0 MB]									
<=: RETURN [EXEC]:SAVE/CANCEL									

5. Turn the jog dial to select the data to copy and press [EXECUTE]

- The cursor moves to the Day under the "START" column of the specified data.
- Press [CANCEL] to return to the screen after Step 4 is executed.
- When copying as specified by the original "START" / "END" time, perform step 7 after this operation.

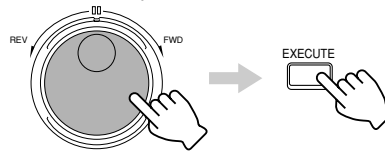

DVD-RAM COPY									
D	M	Y	H	M	AL	FIX			
28	07	2003	10	10	OFF	OFF			
COPY D/M/Y H:M:S(START) D/M/Y H:M:S(END) CAMERA									
○	28-07-03	06:30:16	28-07-03	06:30:16	13	14	15	16	
○	28-07-03	06:30:16	28-07-03	06:30:16	1				
○	28-07-03	06:30:16	28-07-03	06:30:16	5				
○	28-07-03	06:30:16	28-07-03	06:30:16	9				
○	28-07-03	06:30:14	28-07-03	06:30:14	13	14	15	16	
○	28-07-03	06:30:14	28-07-03	06:30:14	1				
○	28-07-03	06:30:14	28-07-03	06:30:14	5				
○	28-07-03	06:30:13	28-07-03	06:30:13	9				
COPY START CAPA[4473 MB] RESV[0 MB]									
<=: RETURN [EXEC]:SAVE/CANCEL									

6. Turn the jog dial to select the copy range

- Use [▷] and the jog dial to set the starting/ending time of DVD-Ram Copy.
- Press [CANCEL] to return to the screen after Step 4 is executed.
- The line will be displayed in green after the original "START" / "END" time has been changed.

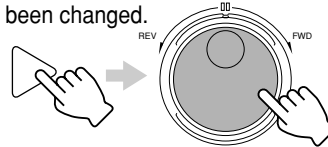

7. Press the [EXECUTE] button

- This displays the [○] mark and the entire line is highlighted.



- Repeat Steps 5 ~ 7 to continue marking data to be copied with the [○] mark displayed.

DVD-RAM COPY									
D	M	Y	H	M	AL	FIX			
28	07	2003	10	10	OFF	OFF			
COPY D/M/Y H:M:S(START) D/M/Y H:M:S(END) CAMERA									
○	28-07-03	06:30:16	28-07-03	06:30:16	13	14	15	16	
○	28-07-03	06:30:16	28-07-03	06:30:16	1				
○	28-07-03	06:30:16	28-07-03	06:30:16	5				
○	28-07-03	06:30:16	28-07-03	06:30:16	9				
○	28-07-03	06:30:14	28-07-03	06:30:14	13	14	15	16	
○	28-07-03	06:30:14	28-07-03	06:30:14	1				
○	28-07-03	06:30:14	28-07-03	06:30:14	5				
○	28-07-03	06:30:13	28-07-03	06:30:13	9				
COPY START CAPA[4473 MB] RESV[0 MB]									
<=: RETURN [EXEC]:SAVE/CANCEL									

8. Select "COPY START" using [▽] and press [EXECUTE]

- The "DVD-RAM COPY CONFIRMATION" screen will be displayed.



DVD-RAM COPY CONFIRMATION	
START COPY TO DVD-RAM START?	
[CANCEL]:CANCEL	[EXEC]:START

9. Press the [EXECUTE] button again

- The unit enters "DVD-RAM COPY" mode, and starts copying.
- Press [CANCEL] during Copy to cancel the operation.
- Upon completion, the "COPY HAS BEEN COMPLETED" message will be displayed.



DVD-RAM COPY	
COPY HAS BEEN COMPLETED	
[SEARCH]: SEE LIST ON DVD-RAM	[OPERATE]: REMOVE DVD-RAM TO END

Useful Features (continued)

Activation of Recording Via External Alarm/Sensor Signals

When signals from alarm devices are input via the [ALARM IN] terminal on the rear panel, recording will automatically start in the mode as specified for the "REC MODE" item in the "ALARM/SENSOR MODE" Menu (☞ Page 27). Alarm recording will be executed if alarm signals are received when VR-716 is in the Recording mode. Sensor recording will be executed when in the Stop mode. In other words, naming varies according to the mode of VR-716.

<Example>
Set the record mode for Cameras 1 - 4 and Cameras 9 - 12.
 ※ Before doing so, ensure that setting for Cameras 1 - 4 and Cameras 9 - 12 in the "REC MODE" Menu is completed.
 ☞ Page 36 'Recording in the Normal Mode'

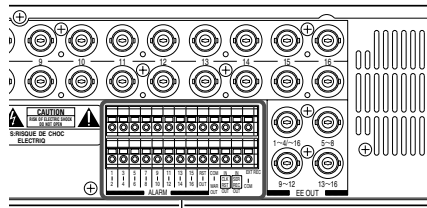

1.

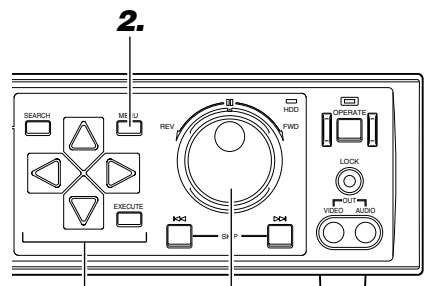

3.5.

4.5.

1. Connect the alarm device to the 'Signal Input/Output terminal' on the rear panel of the equipment

- Connect the alarm device to the [ALARM IN 1 ~ ALARM IN 4] and [ALARM IN 9 ~ ALARM IN 12] terminals.

2. Press the [MENU] button

- Follow procedures in 'Changing Menu Settings' on page 22 to display the "ALARM/SENSOR MODE" Menu.

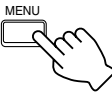

3. Press [▽] to select the "BLOCK" item

- Move the cursor to select.

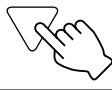

ALARM/SENSOR MODE	
1.BLOCK	1
2.REC MODE	ALARM
3.FRAME RATE	25 IPS
4.QUALITY	H
5.DURATION	180SEC
6.AUDIO REC	ON
7.PRESENSOR REC	OFF
8.PRESENSOR REC DURATION	10SEC
9.EXT INPUT OPERATING MODE	OFF
10.MOTION DETECT	OFF
11.MOTION DETECT SETTING	▶

4. Turn the jog dial to select "1"

- Setting can now be performed for Camera 1 ~ Camera 4.

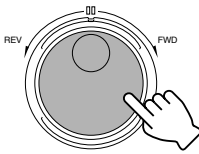

ALARM/SENSOR MODE	
1.BLOCK	1
2.REC MODE	ALARM
3.FRAME RATE	25 IPS
4.QUALITY	H
5.DURATION	180SEC
6.AUDIO REC	ON
7.PRESENSOR REC	OFF
8.PRESENSOR REC DURATION	10SEC
9.EXT INPUT OPERATING MODE	OFF
10.MOTION DETECT	OFF
11.MOTION DETECT SETTING	▶

5. Press [▽] and turn the jog dial to select "REC MODE" to set a value

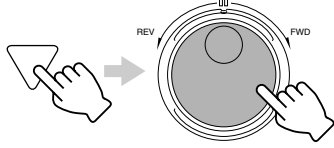

ALARM/SENSOR MODE	
1.BLOCK	1
2.REC MODE	ALARM
3.FRAME RATE	25 IPS
4.QUALITY	H
5.DURATION	180SEC
6.AUDIO REC	ON
7.PRESENSOR REC	OFF
8.PRESENSOR REC DURATION	10SEC
9.EXT INPUT OPERATING MODE	OFF
10.MOTION DETECT	OFF
11.MOTION DETECT SETTING	▶

- For selecting a record mode.
- For selecting the frame rate during recording.
- For selecting the picture quality during recording.
- For selecting the duration of recording.
- For selecting whether to execute audio recording during recording.
- For selecting the duration of presensor recording. ☞ Page 113 'Presensor Recording'
- For selecting whether to activate presensor recording.
- For setting the operation of the record mode. ☞ Page 28 'ALARM/SENSOR MODE Menu'

<Types of Record Modes>

- "ALARM": Starts alarm recording only when VR-716 is in the Recording mode.
- "SENSOR": Starts sensor recording only when VR-716 is in the Stop mode.
- "ALARM/SENSOR": Starts alarm recording when VR-716 is in the Recording mode and sensor recording when in the Stop mode.

Notes

- Ensure that the "EXT INPUT OPERATING MODE" (☞ page 28) item is set to "ON". If this is set to "OFF", recording via alarm signals is not possible even when setting is completed.
- About 1 second or less will be required before sensor recording starts upon the input of alarm signals. To resolve this, make use of the 'Presensor Recording' feature. (☞ Page 113)

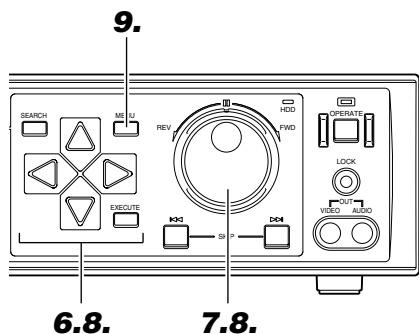

6. Press [\triangle / ∇] to move the cursor to the “BLOCK” item



ALARM/SENSOR MODE	
1.BLOCK	ALARM
2.REC MODE	25 IPS
3.FRAME RATE	H
4.QUALITY	180SEC
5.DURATION	ON
6.AUDIO REC	ON
7.PRESENSOR REC	OFF
8.PRESENSOR REC DURATION	10SEC
9.EXT INPUT OPERATING MODE	OFF
10.MOTION DETECT	OFF
11.MOTION DETECT SETTING	▶

7. Turn the jog dial to select “3”

- Setting can now be performed for Camera 9 ~ Camera 12.

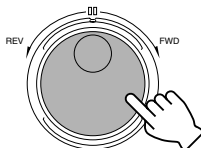

8. Repeat procedure in Step 5 to select the “REC MODE” item and set a value accordingly

9. Press [MENU] to end menu setting

- The display returns to the normal screen.
- The [AL REC] or [SENSOR REC] indicator on the front display will appear.

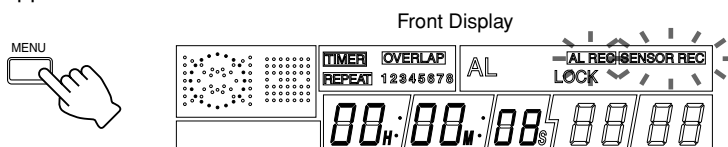

Notes

- In the case when “REC MODE” is set to “ALARM”, press the [REC] button after menu setting is completed. Alarm recording will be executed in the specified mode when alarm input is received.
- In the case when “REC MODE” is set to “SENSOR”, press the [STOP] button after menu setting is completed. Sensor recording will be executed in the specified mode when alarm input is received.
- Press the [CANCEL] button to stop the buzzer sound during alarm or sensor recording. Press the [CANCEL] button again during alarm recording to return to the normal recording mode or during sensor recording to stop the operation.
- Press the [CANCEL] button once again and the Alarm/Sensor [AL] indicator on the front display will stop blinking.

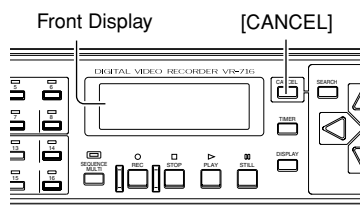

Notification During Alarm Recording or Sensor Recording

FDP/BUZZER [FDP]	ON	OFF
1.ALARM/SENSOR MODE	ON	OFF
2.ALARM/SENSOR BLINK	ON	OFF
3.SEQUENTIAL MONITOR	ON	OFF
4.INPUT SIGNAL ERROR	ON	OFF
5.WARNING [BUZZER]	ON	OFF
1.HDD FULL	OFF	ON
2.ALARM/SENSOR	OFF	ON
3.WARNING	OFF	ON

[AL] indicator on the front display will appear during alarm or sensor recording when this is set to “ON”.

[AL] indicator on the front display will blink after alarm or sensor recording has ended when this is set to “ON”.

Buzzer will sound when this is set to “ON”.

MONITOR DISPLAY	1-16
1.EE OUT 1-4/16	▶
2.SINGLE PICTURE MODE	
3.QUAD PICTURE MODE	
BLOCK 1	1SEC
BLOCK 2	1SEC
BLOCK 3	1SEC
BLOCK 4	1SEC
4.ALARM/SENSOR SWITCH	OFF
5.SPLIT SCREEN BORDER COLOR	BORDER3

For setting the switching mode of the monitor screen when alarm signals are received. [▶](#) Page 26 'MONITOR DISPLAY Menu'

Useful Features (continued)

Using the Motion Detect Feature

VR-716 comes equipped with a Motion Detect feature, whereby the monitor screen is divided into 150 areas and alarm/sensor recording is automatically executed upon detection of image motion within these areas.

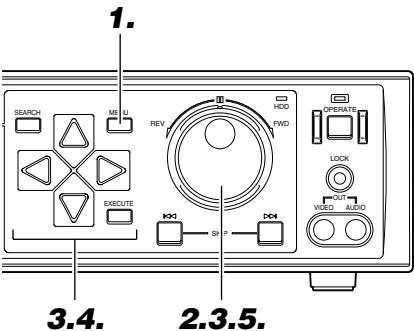

1. Press the [MENU] button

- Follow procedures in 'Changing Menu Settings' on page 22 to display the "ALARM/SENSOR MODE" Menu.

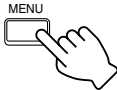

2. Turn the jog dial to select a block

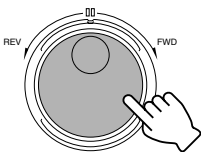

ALARM/SENSOR MODE	
1.BLOCK	ALARM
2.REC MODE	25 IPS
3.FRAME RATE	H
4.QUALITY	180SEC
5.DURATION	ON
6.AUDIO REC	OFF
7.PRESENSOR REC	10SEC
8.PRESENSOR REC DURATION	OFF
9.EXT INPUT OPERATING MODE	OFF
10.MOTION DETECT	OFF
11.MOTION DETECT SETTING	▶

3. Press [▽] and turn the jog dial to set a value for each item

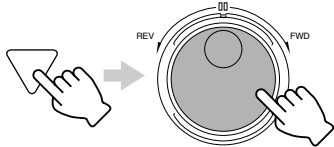

ALARM/SENSOR MODE	
1.BLOCK	1
2.REC MODE	ALARM
3.FRAME RATE	25 IPS
4.QUALITY	H
5.DURATION	180SEC
6.AUDIO REC	ON
7.PRESENSOR REC	OFF
8.PRESENSOR REC DURATION	10SEC
9.EXT INPUT OPERATING MODE	OFF
10.MOTION DETECT	OFF
11.MOTION DETECT SETTING	▶

- For selecting a record mode.
- For selecting the frame rate during recording.
- For selecting the picture quality during recording.
- For selecting the duration of recording.
- For selecting whether to execute audio recording during recording.
- For selecting whether to activate presensor recording. (Page 113 'Presensor Recording')
- For selecting the duration of presensor recording.
- For setting the operation of Motion Detect. (Page 28 'ALARM/SENSOR MODE Menu')

Caution

- When cameras are connected, flickering fluorescent lights may give rise to false detection. In this case, set the camera to flickerless. (Instruction manual of camera used)
- Ensure that an item other than "OFF" is selected for the "MOTION DETECT" item (page 28). Motion Detect will not activate yet after setting is completed.
- The Motion Detect feature is not designed to prevent thefts or fire disasters. We do not bear responsibility for any loss incurred due to accidents or damages.

4. Select the "MOTION DETECT SETTING" item using [▽] and press [▶]

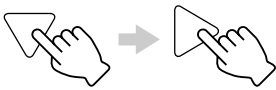

- This displays the "MOTION DETECT SETTING" Menu screen.

MOTION DETECT SETTING	
1.BLOCK	1
2.CAMERA 1 SCENE	MANUAL
3.CAMERA 2 SCENE	MANUAL
4.CAMERA 3 SCENE	MANUAL
5.CAMERA 4 SCENE	MANUAL

5. Turn the jog dial to select "BLOCK"

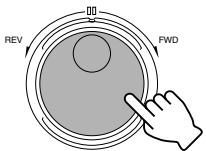

- Set "BLOCK" to "1": Sets detection of motion at Camera 1 ~ Camera 4.
- Set "BLOCK" to "2": Sets detection of motion at Camera 5 ~ Camera 8.
- Set "BLOCK" to "3": Sets detection of motion at Camera 9 ~ Camera 12.
- Set "BLOCK" to "4": Sets detection of motion at Camera 13 ~ Camera 16.

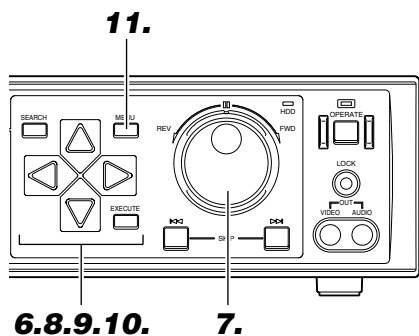

6. Press [] to move the cursor to “SCENE”

- Move the cursor to the camera for which motion is to be detected.

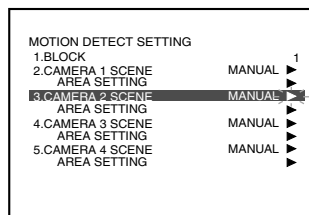

7. Turn the jog dial to select a value

- Select a value from the *Settings* column under “SCENE” on page 28.
- When “MANUAL” is selected, “DETECTING SENSITIVITY”, “TERMINATION SENSITIVITY” and “OBJECT SIZE LEVEL” can be further specified under “DETAIL SETTING”.

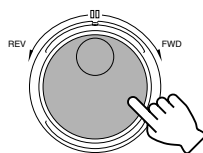

8. Press [] to move the cursor to “AREA SETTING”

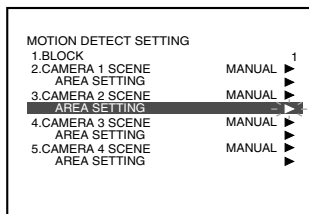

<How to set manually>

- To determine the value for “DETECTING SENSITIVITY”, “TERMINATION SENSITIVITY” and “OBJECT SIZE LEVEL”, when selecting the “SCENE” value other than “STANDARD”, please refer to the detailed setting displayed. (☞ Page 70 ‘Setting’)





Notes

- To alter the “REC MODE” Menu settings before setting at the “AREA SETTING” screen, close the setting screen and open the “AREA SETTING” screen again after alteration is completed. There are cases where live images are not displayed at the background of the “AREA SETTING” screen.
- The monitor screen is divided into 150 areas for detecting motion. To set all 150 areas, press and hold [EXECUTE].
- To clear all 150 areas, press and hold [CANCEL].
- Record mode of Motion Detect (picture quality, frame rate, etc.) is identical to the Alarm Mode settings. (☞ Page 66 ‘Activation of Recording Via External Alarm Signals’)
- After camera setting is completed, capture an actual image to double-check if alarm is properly triggered via Motion Detect as well as its detection sensitivity.

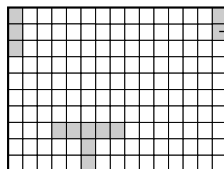
9. Press the [] button

- Select the area for which motion is to be detected.



Use [ /  /  / ] to select the areas and press [EXECUTE]. Areas that are selected will be displayed in a different color on the monitor screen. To undo the selection, press [CANCEL].

- The position can be moved diagonally by pressing buttons simultaneously.
- The position can be moved continuously by pressing and holding the buttons.

- Press and hold [SEARCH] when the “AREA SETTING” screen is displayed to switch to Motion Detect Test mode. (☞ Page 70 ‘Check mode’)
- To exit the Test mode, press [SEARCH] again.

10. Select the areas in the leftmost column and press [] to return to the “MOTION DETECT SETTING” Menu screen

Press [] to return to the “MOTION DETECT SETTING” screen when areas selected are in the leftmost column.

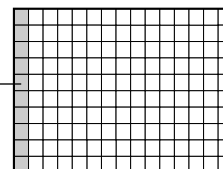

※ Repeat Steps 3 ~ 10 to specify settings for other cameras.

11. Press [MENU] to end setting

- The display returns to the normal screen.

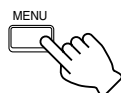

Useful Features (continued)

Motion detect check mode and setting guidance

Check mode

Screen image
Press and hold [SEARCH] button when the "AREA SETTING" screen is displayed to open the check mode screen.

Explanation of the screen content

- **ALARM mark:**
A red [●] will be displayed on the upper left of the screen when ALARM detection is ongoing.
- **Detection area boundary (Blue):**
Boundary of the setting unit area in the "AREA SETTING" screen.
- **Frame of the specified area for detection:**
The area as specified in the "AREA SETTING" will be displayed as a white frame.
- **Detection point (White):**
The point where motion has reached the "DETECTING SENSITIVITY" will be displayed as a white dot. ALARM detection will be activated if the number of white dot hits the number of "OBJECT SIZE LEVEL".
- **Detection point (Green):**
The point where motion has reached between the "DETECTING SENSITIVITY" and "TERMINATION SENSITIVITY" will be displayed as a green dot.
- **Graph of sum total for detection point (Yellow):**
The changes in the display number of white dot will be displayed with the x-axis as the elapsed time.

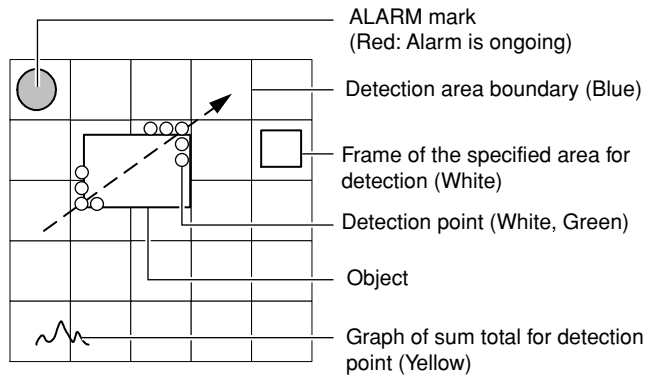

Setting

Setting value for different scene

For setting to other than "STANDARD", refer to the setting value from the arrow on the right side of "SCENE" in the menu.

Table 1: Setting value for different scene

"SCENE"	Detailed setting			Alarm operation Minimum number of detection point *1
	"DETECTING SENSITIVITY"	"TERMINATION SENSITIVITY"	"OBJECT SIZE LEVEL"	
"STANDARD"	-	-	-	2
"DOORWAY H"	10	+1	2	2
"DOORWAY L"	7	+4	3	4
"PASSAGE H"	9	+0	2	2
"PASSAGE L"	8	+3	3	4
"REGISTER H"	10	+2	1	1
"REGISTER L"	10	+2	3	4
"ATM H"	10	+3	1	1
"ATM L"	8	+5	8	20 *2
"LOBBY H"	10	+4	2	2
"LOBBY L"	7	+8	3	4
"GATE H"	14	+0	1	1
"GATE L"	10	+4	5	8
"PARKING LOT H"	14	+0	1	1
"PARKING LOT L"	10	+4	6	10 *2
"LOW LUX H"	15	+0	2	2
"LOW LUX L"	12	+0	4	6
"ELEVATOR"	8	+4	2	2
"COUNTER"	6	+5	4	6

*1 Number of white dot displayed in check mode

*2 The maximum number of point to be detected within one area is 9. Set the number of area such that the sum total of detection point exceeds the minimum number of detection point.

Table 2: "OBJECT SIZE LEVEL" and "Alarm operation Minimum number of detection point"

"OBJECT SIZE LEVEL"	1	2	3	4	5	6	7	8	9	10
Alarm operation Minimum number of detection point	1	2	4	6	8	10	15	20	25	30

Continuing with Recording Upon Recovery from Power Failure

VR-716 is equipped with a Recovery Recording feature that starts recording automatically upon recovery from a power failure. With this feature, restoration procedure will not be required when a power failure occurs during recording.

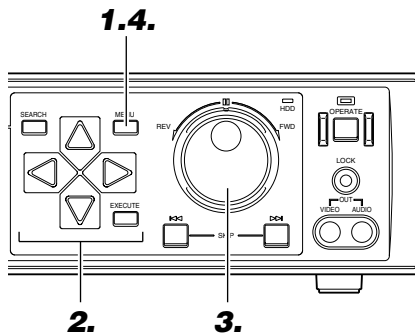

1. Press the [MENU] button

- Follow procedures in 'Changing Menu Settings' on page 22 to display the "OPERATION/EXT REC" Menu.

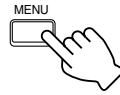

OPERATION/EXT REC	
[OPERATION]	
1.RECOVERY REC	OFF
2.REPEAT REC	OFF
3.LANGUAGE SELECTION	ENGLISH
4.WATER MARK	OFF
5.OPERATION LOCK	ALL
[EXT REC]	
1.EXT REC MODE	OFF
2.SERIES REC	OFF

2. Press [▽] to select the "RECOVERY REC" item

- Move the cursor to select.



3. Turn the jog dial to select an operating mode

- "PRIOR STATE":

When a power failure occurs during recording, recording will start again upon restoration. If power failure occurs when the equipment is in the Sensor Record mode (☞ page 66), however, recording will not start automatically upon restoration.

- "NORMAL REC":

Recording resumes upon recovery from a power failure, regardless of the mode prior to the failure.

OPERATION/EXT REC	
[OPERATION]	
1.RECOVERY REC	NORMAL REC
2.REPEAT REC	OFF
3.LANGUAGE SELECTION	ENGLISH
4.WATER MARK	OFF
5.OPERATION LOCK	ALL
[EXT REC]	
1.EXT REC MODE	OFF
2.SERIES REC	OFF

Note

- The "POWER OUTAGE LOG IS UPDATED" message will be displayed on the monitor only when the "WARNING" item in the "ONSCREEN MODE" Menu (☞ page 23) is set to "ON". Press the [CANCEL] button to clear the message display.

Caution

- Hard Disk Checking is performed upon recovery from a power failure, which may take a while before recording starts. It may take a long time when the data is fragmented or when there is a large amount of recorded data.
- A list containing the date and time at which power failure is restored can be viewed. (☞ Page 60)
- When the Program Timer is set, recording will resume in the same mode after restoring from a power failure.

4. Press [MENU] to end setting

- The display returns to the normal screen.

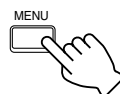

Notification of Power Outage

- The following message will be displayed on the monitor screen when a power outage occurs, and the [other E-04] message will appear on the front display.

01-03-2003 SA 12:34:56
100%
AL-0
POWER OUTAGE LOG IS UPDATED

Useful Features (continued)

Setting a Title for Each Camera Channel Screen

<Example>
Register the title for Camera 1 as [ENTRANCE1].

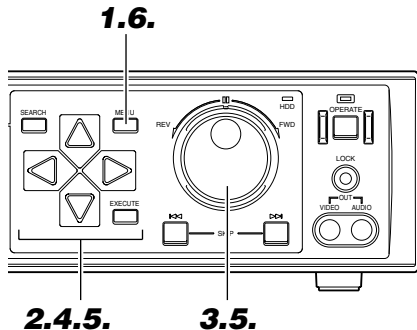

1. Press the [MENU] button

- Follow procedures in 'Changing Menu Settings' on page 22 to display the "CAMERA TITLE" Menu.

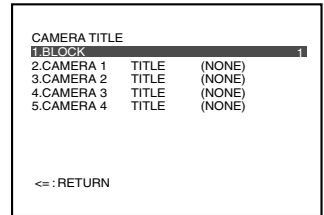
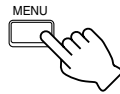

2. Press [▽] to select the "BLOCK" item

- Move the cursor to select.



3. Turn the jog dial to set "BLOCK" to "1"

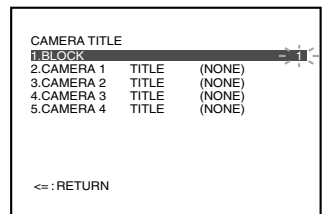
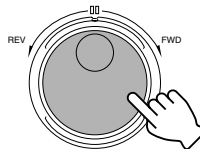

4. Press [▽] to select the "CAMERA 1 TITLE" item

- Move the cursor to select.

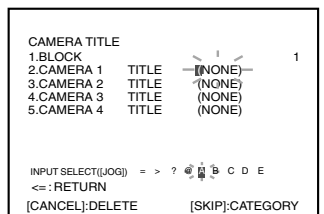

5. Turn the jog dial to select a character

- Upon moving the cursor to [E], press [▷] to move the cursor forward and continue to select [N], [T], [R], [A], [N], [C], [E] and [1] accordingly.

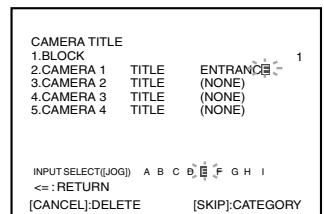
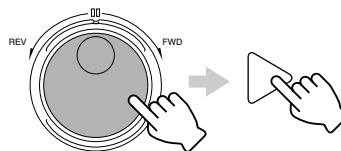

※ Repeat Steps 2 ~ 5 to register titles for other cameras.

6. Press [MENU] to end setting

- The display returns to the normal screen.



<Characters that can be used in camera titles>

(Excludes the case when title is set using a computer.)

ABCDEFGHIJKLMNOPQRSTUVWXYZ

[] ^ _ ` abcdefghijklmnopqrstuvwxyz { | } ~

¡ ¢ £ ¤ ¥ ¦ § ¨ © ª « ¬ ® ¯ ° ± ² ³ ´ µ ¶ · ¸ ¹ º » ¼ ½ ¾ ¿

À Á Â Ã Ä Å Æ Ç È É Ê Ë Ì Í Î Ï Ñ Ò Ó Ô Õ Ö × Ø Ù Ú Û Ü Ý Þ ß

à á â ã ä å æ ç è é ê ë ì í î ï ð ñ ò ó ô õ ö ÷ ø ù ú û ý þ ÿ

! # \$ % & () * + , - . / 0 1 2 3 4 5 6 7 8 9 ; < = > ? @

※ Up to 15 characters can be used when registering the camera title.

Note

- To clear a registered character, use [◀/▶] to select the character and press [CANCEL].

Connecting to a PC – What is a Web Browser? –

You can do the followings

By connecting to a PC via a LAN cable, images recorded on VR-716 can be viewed on the PC monitor.

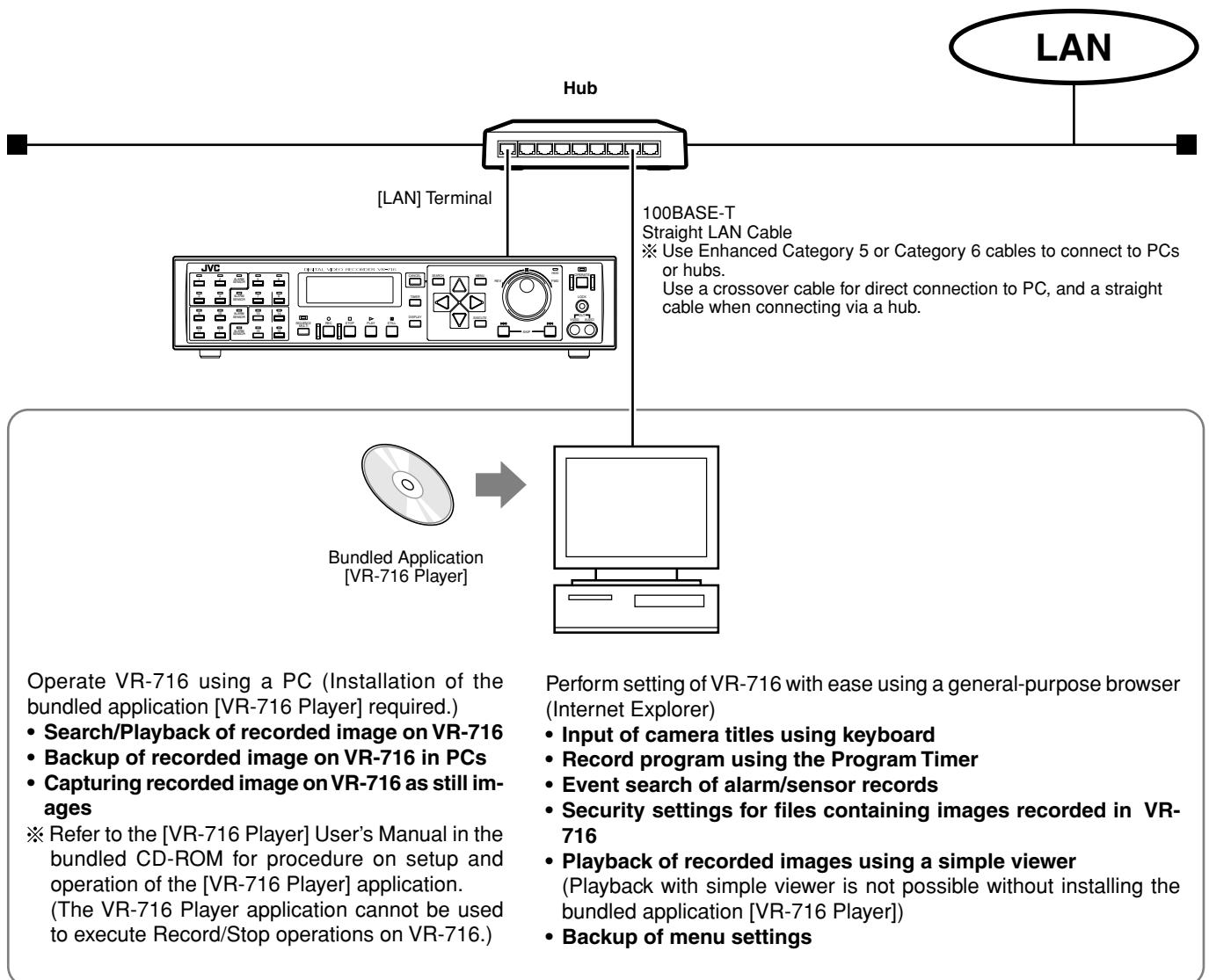

Note

- The PC specifications above are merely recommended example for using the application software with ease and is not a guarantee against its operation. Even when the PC fulfills the necessary operating conditions, its performance may vary across individual users depending how the PC is used.

Caution

- Simultaneous playback of images from a single VR-716 on multiple PCs is not possible.

Cautions for Proper Use of the Web Browser

■ Minimum PC Specifications Required

- OS : Windows 2000 Professional SP4 / Windows XP Professional SP1 / Windows XP Home Edition SP1
 - CPU : Pentium III 800MHz and above
 - Memory : 256 MB and above
 - Hard Disk : At least 50 MB of free space is required to install the bundled application software.
 - Monitor : XGA (1024 x 768 pixels) and above required
SXGA (1280 x 1024 pixels) recommended
- ※ Supports Internet Explorer Ver. 5.5 (SP2) / Ver. 6.0.
In addition, Internet Explorer 5.0 is not supported.

■ Other Cautions

- Assuming that the Web browser is used in an Intranet environment in this case, disable the proxy server by selecting the “Internet Options” → “Connection” from the Internet Explorer.
- Priority will be given to operation at the main unit of VR-716 when it is in the Recording, Timer Standby or Operating modes. Operation using a Web browser or simple viewer will be restricted in this case.

Note

- The PC specifications are merely recommended example for using the application software with ease and is not a guarantee against its operation. Even when the PC fulfils the necessary operating conditions, its performance may vary across individual users depending how the PC is used.

Setup Flow

Connecting Using a LAN Cable

📖 Page 76

Setting Up a Network for VR-716

📖 Page 77

- Set the "IP ADDRESS".
- Set the "NETMASK".
- Set the "DEFAULT GATEWAY".

Setting Up a PC Network

📖 Page 78

- Set the "IP address".
- Set the "Subnet mask".

WindowsXP 📖 Page 78
Windows2000 📖 Page 79

Connecting (Login) to the Network

📖 Page 81

Setting a Title
for Each Camera
Channel Screen
📖 Page 82

Record Program
Using the
Program Timer
📖 Page 83

Searching Image
According to
Date/Time
(Event Search)
📖 Page 91

Notes

- ◆ What is IP address?
📖 Page 110
- ◆ What is subnet mask?
📖 Page 110
- ◆ What is default gateway?
📖 Page 110

- ◆ What is Login?
📖 Page 110

Connecting Using a LAN Cable

■ Connecting to a (LAN) Network

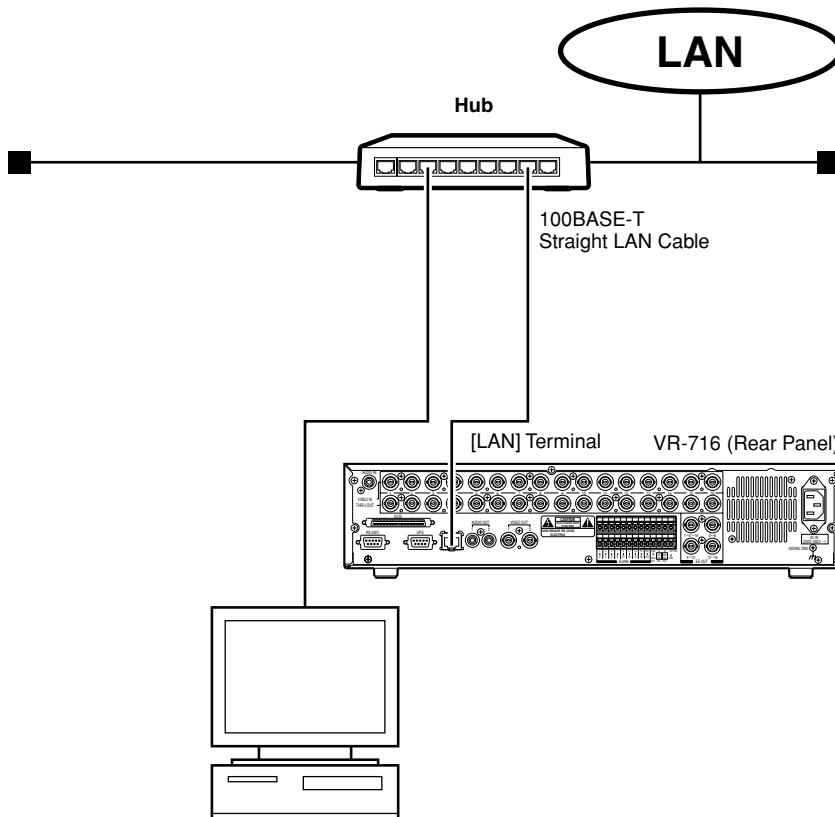

Notes

- ◆ What is LAN?
Page 110
- ◆ Use Enhanced Category 5 or Category 6 cables to connect to PCs or hubs. Use a crossover cable for direct connection to PC, and a straight cable when connecting via a hub.
- ◆ Consult the network administrator when connecting to an existing LAN line.

Caution

- Simultaneous playback of images from 1 VR-716 on multiple PCs is not possible.

■ Connecting to a Peer-to-peer Network

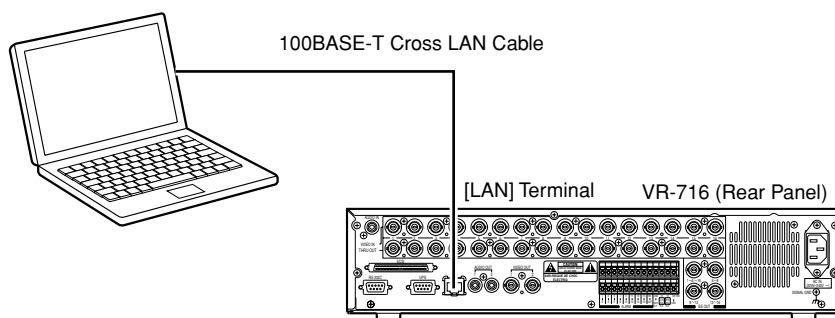

Note

- ◆ What is peer-to-peer?
Page 110

Caution

- Unplug the power cord of VR-716 before connecting the LAN cable.

Setting Up a Network for VR-716

Perform the initial setup at the main unit of VR-716 by referring to the monitor screen connected to VR-716.

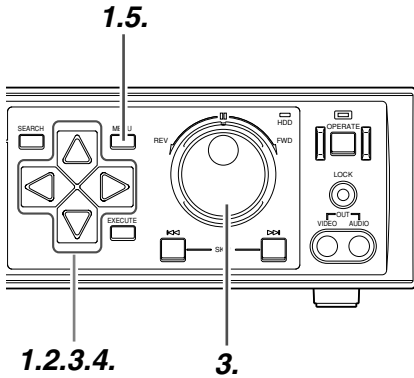

1. Press the [MENU] button

- Use [▽] to move the cursor to “NETWORK”.

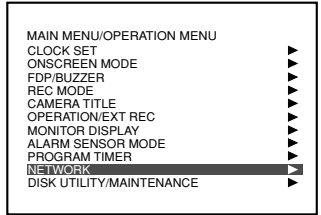
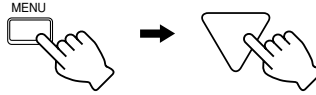

2. Press the [▶] button

- Displays the “NETWORK” screen.

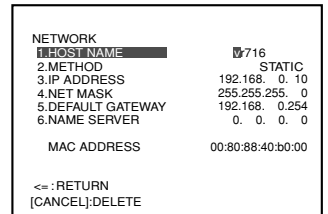

※ Factory settings are as follows:

- “METHOD” : “STATIC” (DHCP not used)
- “IP ADDRESS” : 192.168.0.10
- “NET MASK” : 255.255.255.0
- “DEFAULT GATEWAY” : 192.168.0.254

Consult the network administrator if there are prescribed settings in the LAN environment for which VR-716 is to be connected.

Notes

- If DHCP is selected, DHCP server assigned by IP address will be displayed when displaying this menu again after exiting it. (Cannot be altered.)
- When “DHCP” is selected, this unit will only acquire the IP address during startup or changing of setting. When the network is valid after startup, to acquire the IP address, set “METHOD” back to “DHCP” if it has been set otherwise.

3. Press [▽] to move the cursor to the item to be altered and turn the jog dial.

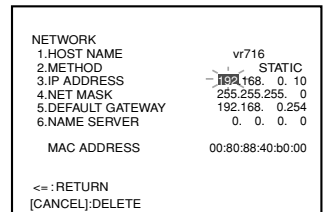
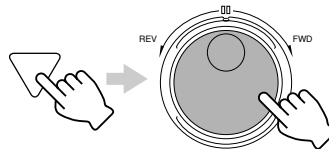

4. Move the cursor to “<=: RETURN” using [▽] and press [◀]

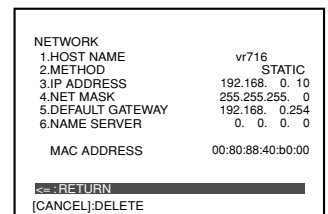

5. Press [MENU] to end setting

- The display returns to the normal screen. (“IP ADDRESS SETTING IN PROGRESS...” may be displayed.)

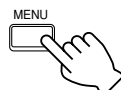

Connecting to a PC - Connecting to a Web Browser and Setting Up - (continued)

The following illustrates how to set up a small LAN using VR-716's factory settings.

Example

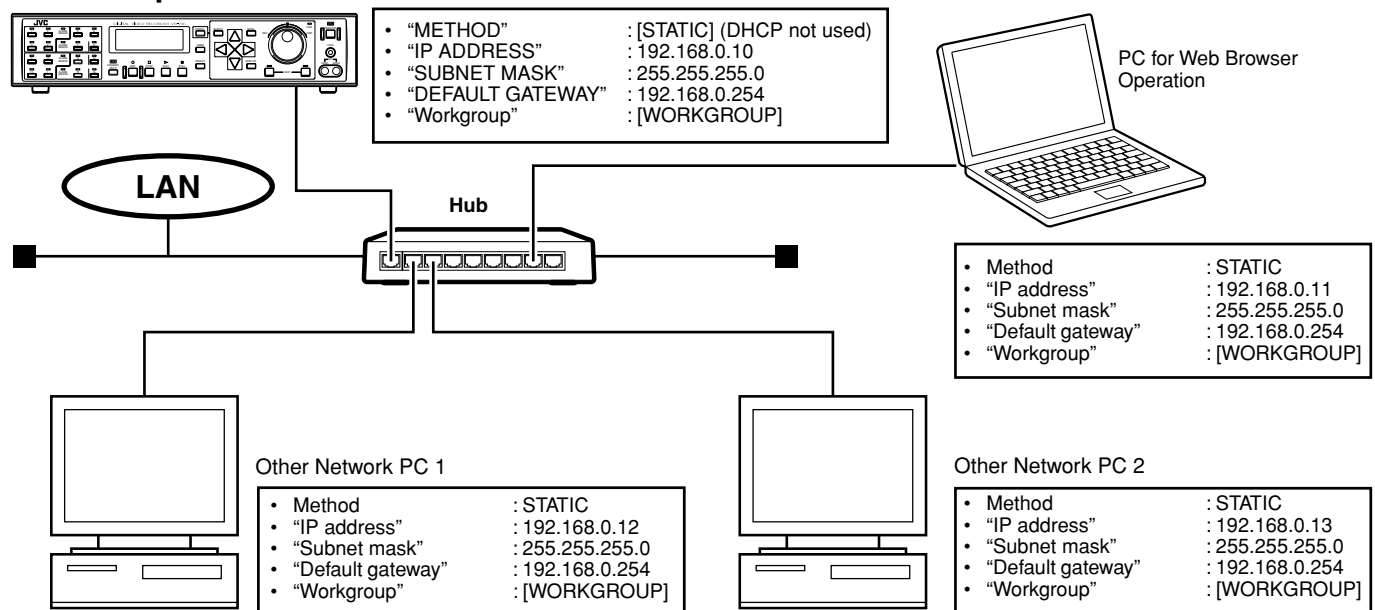

Setting Up a PC Network (Windows XP)

When Using Windows XP

1. Click the start button

- Right-click on "My Network Places" and select "Properties".

2. Select the network for which the PC used for Web browser operation is connected

- Right-click and select "Properties".

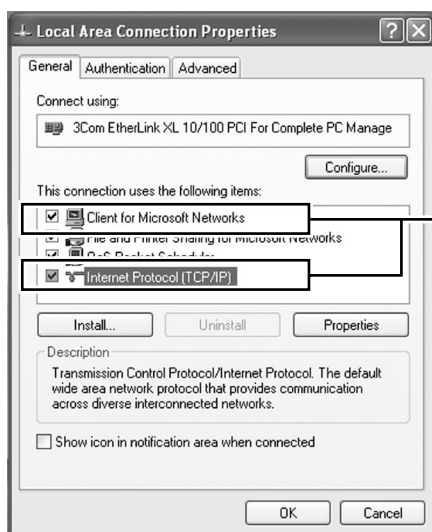

- Proceed to page 80 step 3.

Notes

- Install accordingly if [Client for Microsoft Networks] and [Internet Protocol (TCP/IP)] are not displayed. Refer to Windows Help Menu for the installation procedure.

- ◆ What is TCP/IP? [Page 110](#)
- ◆ What is DHCP? [Page 110](#)
- ◆ What is Workgroup? [Page 110](#)

Setting Up a PC Network (Windows 2000)

When Using Windows 2000

1. Click the Start button

- Click “Settings” → “Control Panel”.
- Double-click to open the “Network and Dial-up Connections” screen.

2. Select “Local Area Connection”

- Right-click “Local Area Connection” and click “Properties”.

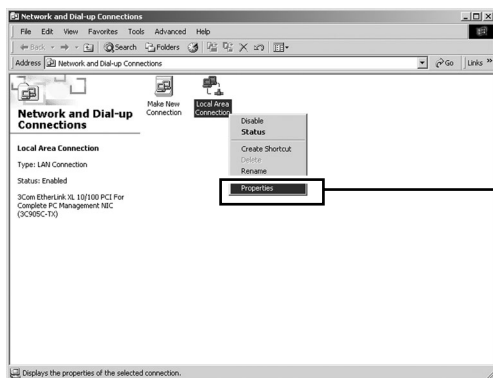

- Proceed to page 80 step 3.

Setting Up a PC Network (Windows 2000/XP)

3. Select [Internet Protocol (TCP/IP)] and click

Properties

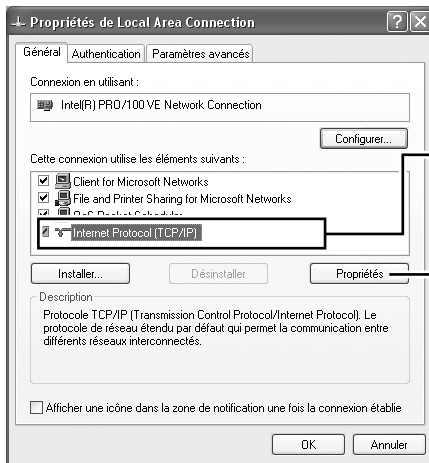

1 Select [Internet Protocol (TCP/IP)].

2 Click "Properties".

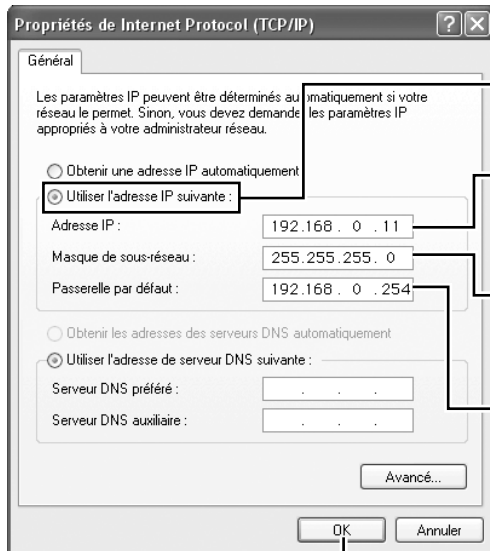

3 Select "Use the following IP address".

4 Set the "IP address" to 192.168.0.11.

5 Set the "Subnet mask" to 255.255.255.0.

6 Set the "Default gateway" to 192.168.0.254.

7 Click "OK".

Note

- This is the screen of Windows XP. The screen will be slightly different in the case of Windows 2000.

Caution

- Do not use the same "IP address" within a network environment during setting.

4. Click on the "Local Area Connection Properties" screen.

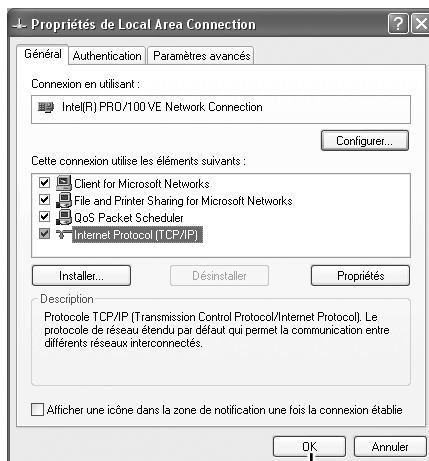

1 Click "OK".

Connecting (Login) to the Network

1. Start the Web browser

2. Enter the IP address for VR-716 in **Address** (factory setting: 192.168.0.10)

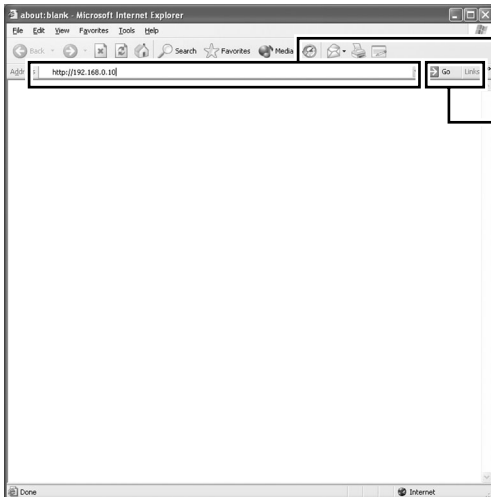

- 1 Enter the IP address (factory setting: 192.168.0.10)
- 2 Click "Go".

3. Enter the login password for VR-716



- 1 Enter [admin] (lower case).
- 2 Enter [vr-716] (lower case).
- 3 Click "OK".

Note

- ◆ Login password to VR-716 can be altered via operation at the web browser.

Page 94

Factory setting:
User name : [admin] (lower case)
Password : [vr-716] (lower case)

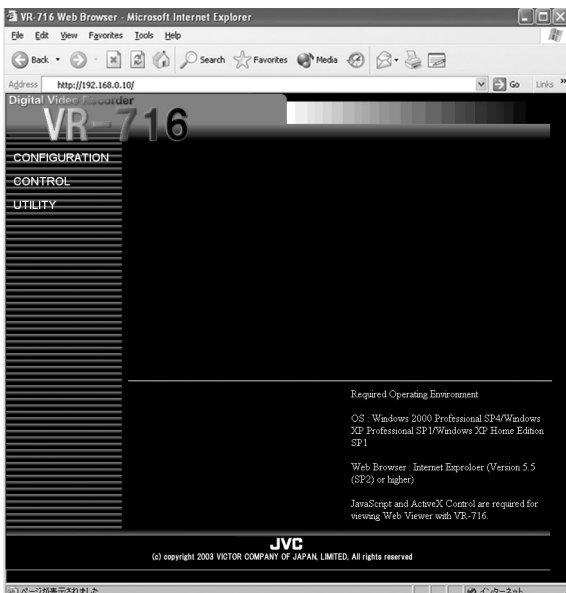

Top Page

Connecting to a PC – Routine Uses of the Web Browser –

Setting a Title for Each Camera Channel Screen

1. Click **CONTROL** → **CAMERA TITLE**

2. Set the camera title

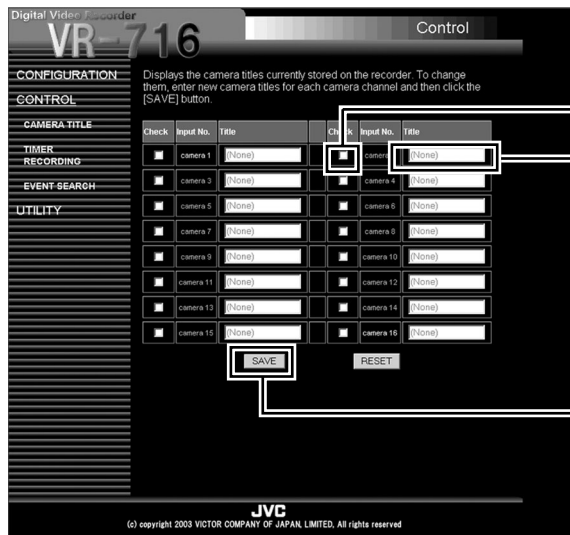

① Click the [Check] box.

② Enter characters of the camera title.

③ Click [SAVE].

Notes

- Up to 15 characters can be used when setting the camera title.
- Clicking [SAVE] with the field left blank will reset the camera title.
- Click [SAVE] to save the title at VR-716.
- Corrections cannot be made once [SAVE] is clicked. To make corrections, re-enter the title.
- Click [RESET] will restore the value on the main unit.
- When the [Camera **] under [Input No.] is displayed in orange, it indicates that the "Camera **" item under the "REC MODE" menu in the main menu is set to "OFF".

Caution

- Camera title input is disabled if [Check] box is not clicked.
- Click [SAVE] only after all camera titles have been updated.
- Alteration of camera titles is not possible when VR-716 is in the Recording mode.

Record Program Using the Program Timer (Setting Screen)

1. Click **CONTROL** → **TIMER RECORDING** → **WEEKLY TIMER**

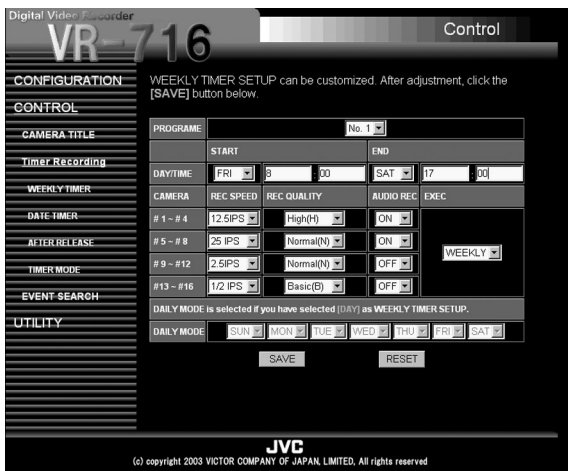

- **Display Area in Program List for Weekly Timer**
 - [PROGRAM LIST FOR WEEKLY TIMER] can be displayed, updated or deleted.



Note

- The [PROGRAM LIST FOR WEEKLY TIMER] has the following meaning:
 SPE: REC SPEED
 QUL: REC QUALITY
 AUD: AUDIO REC

Connecting to a PC – Routine Uses of the Web Browser – (continued)

Record Program Using the Program Timer (Start recording on a specific time of the week)

<Example> Execute recording from 8:00 a.m. every Friday ~ 5:00 p.m. every Saturday.

Recording Mode

- | | | | |
|---------------------|---------------------|---------------------|---------------------|
| • [CAMERA] 1 - 4 | • [CAMERA] 5 - 8 | • [CAMERA] 9 - 12 | • [CAMERA] 13 - 16 |
| [REC SPEED] : 12.5 | [REC SPEED] : 25 | [REC SPEED] : 2.5 | [REC SPEED] : 1/2 |
| [REC QUALITY] : [H] | [REC QUALITY] : [N] | [REC QUALITY] : [N] | [REC QUALITY] : [B] |
| [AUDIO REC] : [ON] | [AUDIO REC] : [ON] | [AUDIO REC] : [OFF] | [AUDIO REC] : [OFF] |

1. Click **CONTROL** → **TIMER RECORDING** → **WEEKLY TIMER**

Notes

- A maximum of 8 record programs can be set using the Weekly Timer.
- Only numbers that have not been programmed are displayed in the [PROGRAM] field.
- When [1/12 IPS] (1 image per 12 seconds) or [1/6 IPS] (1 image per 6 seconds) is selected for [REC SPEED], audio recording is set automatically to "OFF" and this cannot be altered.
- Click [SAVE] to save settings at VR-716.
- Click [RESET] when settings are incorrectly entered.
- Upon clicking [SAVE], restoration of the original preset value will not be possible.

Caution

- When all the "CAMERA" settings of a particular "BLOCK" in VR-716's "REC MODE" Menu are set to "OFF", the "FRAME RATE", "REC QUALITY" and "AUDIO REC" settings for that block cannot be altered.
- Refer to the notes related to Summer Time. (☞ Page 116)

No.	DAYTIME (START) (END)	# 1 - # 4			# 5 - # 8			# 9 - # 12			# 13 - # 16			EXEC	UP	DE
		SPE	QUL	AUD	SPE	QUL	AUD	SPE	QUL	AUD	SPE	QUL	AUD			
1	FRI 09:00 SAT 17:00	12.5	H	A	25	N	A	2.5	N	-	1/2	B	-	WEEKLY	UP	DE
2	MON ***	***	***	***	***	***	***	***	***	***	***	***	***	***	UP	DE
3	TUE ***	***	***	***	***	***	***	***	***	***	***	***	***	***	UP	DE
4	WED ***	***	***	***	***	***	***	***	***	***	***	***	***	***	UP	DE
5	THU ***	***	***	***	***	***	***	***	***	***	***	***	***	***	UP	DE
6	FRI ***	***	***	***	***	***	***	***	***	***	***	***	***	***	UP	DE
7	SAT ***	***	***	***	***	***	***	***	***	***	***	***	***	***	UP	DE
8	DAY ***	***	***	***	***	***	***	***	***	***	***	***	***	***	UP	DE

2. Set to the Program Timer Standby mode

☞ Page 88 'Setting VR-716 to the Program Timer Standby Mode'

Record Program Using the Program Timer (Start recording at a specific time everyday)

<Example> Execute recording from 8:00 a.m. ~ 5:00 p.m. everyday.

Recording Mode

- [CAMERA] 1 - 4
[REC SPEED] : 12.5
[REC QUALITY] : [H]
[AUDIO REC] : [ON]
- [CAMERA] 5 - 8
[REC SPEED] : 25
[REC QUALITY] : [N]
[AUDIO REC] : [ON]
- [CAMERA] 9 - 12
[REC SPEED] : 2.5
[REC QUALITY] : [N]
[AUDIO REC] : [OFF]
- [CAMERA] 13 - 16
[REC SPEED] : 1/2
[REC QUALITY] : [B]
[AUDIO REC] : [OFF]

1. Click **CONTROL** → **TIMER RECORDING** → **WEEKLY TIMER**

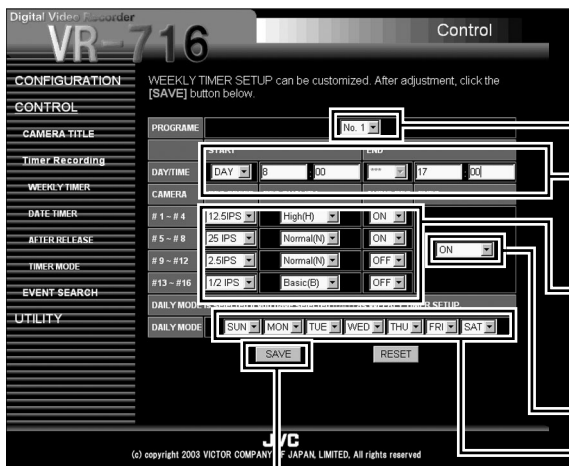

- ① Select the Program No..
 - ② Select the day/time for recording to start and end. Set [START] DAY to [DAY].
 - ③ Select the [REC SPEED], [REC QUALITY] and [AUDIO REC] for each camera channel.
 - ④ Select [ON].
 - ⑤ Check that all days of a week have been selected.
- Click [SAVE].

Notes

- [END] DAY cannot be set if [DAY] is selected for [START] DAY.
- Only [ON] or [OFF] can be selected under [EXEC] if [DAY] is selected for [START] DAY.

Caution

- Refer to the notes related to Summer Time. (Page 116)

Note

Program List for Weekly Timer

Press [UP] to change and [DEL] to clear preset values.



Program List for Weekly Timer

2. Set to the Program Timer Standby mode

Page 88 'Setting VR-716 to the Program Timer Standby Mode'

Connecting to a PC – Routine Uses of the Web Browser – (continued)

Record Program Using the Program Timer (Start recording on a specific day and time)

<Example> Execute recording from 9:30 a.m. ~ 10:30 p.m. on every Monday, Wednesday and Friday.

Recording Mode

- | | | | |
|---------------------|---------------------|---------------------|---------------------|
| • [CAMERA] 1 - 4 | • [CAMERA] 5 - 8 | • [CAMERA] 9 - 12 | • [CAMERA] 13 - 16 |
| [REC SPEED] : 12.5 | [REC SPEED] : 25 | [REC SPEED] : 2.5 | [REC SPEED] : 1/2 |
| [REC QUALITY] : [H] | [REC QUALITY] : [N] | [REC QUALITY] : [N] | [REC QUALITY] : [B] |
| [AUDIO REC] : [ON] | [AUDIO REC] : [ON] | [AUDIO REC] : [OFF] | [AUDIO REC] : [OFF] |

1. Click **CONTROL** → **TIMER RECORDING** → **WEEKLY TIMER**

1 Select the Program No..

2 Select the day/time for recording to start and end. Set [START DAY] to [DAY].

3 Select the [REC SPEED], [REC QUALITY] and [AUDIO REC] for each camera channel.

4 Select [ON].

5 Select [***] for setting other than [MON], [WED] and [FRI].

7 Click [SAVE].

Notes

- [END] DAY cannot be set if [DAY] is selected for [START] DAY.
- Only [ON] or [OFF] can be selected under [EXEC] if [DAY] is selected for [START] DAY.

Caution

- Refer to the notes related to Summer Time. (Page 116)

Notes

- [DAILY MODE] can be set when [DAY] is selected at [START] DAY. Select [***] for days for which recording is not to be executed, followed by clicking [SAVE].

Program List for Weekly Timer

Press [UP] to change and [DEL] to clear preset values.

Be careful when [DAY] is selected for other Program Nos. As all record programs with [DAY] selected will be set at the same time.

- Click [SAVE] to save settings at VR-716.
- Click [RESET] when settings are incorrectly entered. This restores the setting saved at the recorder.
- Upon clicking [SAVE], restoration of the original preset value will not be possible.

6 Click [UP] to update setting for the Program No. selected in ①.

Program List for Weekly Timer.

No.	DAYTIME (START)	DAYTIME (END)	#1-#4	#5-#8	#9-#12	#13-#16	EXEC	UP	DEL								
			SPE QUL AUD	SPE QUL AUD	SPE QUL AUD	SPE QUL AUD											
1	DAY	09:30	***	22:30	12.5	H	A	25	N	A	2.5	N	1/2	B	ON	UP	DEL
2	MON	***	***	***	***	***	***	***	***	***	***	***	***	***	***	UP	DEL
3	TUE	***	***	***	***	***	***	***	***	***	***	***	***	***	***	UP	DEL
4	WED	***	***	***	***	***	***	***	***	***	***	***	***	***	***	UP	DEL
5	THU	***	***	***	***	***	***	***	***	***	***	***	***	***	***	UP	DEL
6	FRI	***	***	***	***	***	***	***	***	***	***	***	***	***	***	UP	DEL
7	SAT	***	***	***	***	***	***	***	***	***	***	***	***	***	***	UP	DEL
8	DAY	***	***	***	***	***	***	***	***	***	***	***	***	***	***	UP	DEL

Current, DAILY MODE is selected because you have selected [DAY] as WEEKLY TIMER SETUP.

DAILY MODE: *** MON *** WED *** FRI ***

CLOSE

2. Set to the Program Timer Standby mode

Page 88 'Setting VR-716 to the Program Timer Standby Mode'

Record Program Using the Program Timer (Start recording at a specific date)

<Example> Execute recording from 8:00 a.m. ~ 11:00 p.m. on 1 October.

Recording Mode

- [CAMERA] 1 - 4
[REC SPEED] : 8.3
[REC QUALITY] : [H]
[AUDIO REC] : [ON]
- [CAMERA] 5 - 8
DO NOT RECORD
- [CAMERA] 9 - 12
[REC SPEED] : 4.2
[REC QUALITY] : [B]
[AUDIO REC] : [OFF]
- [CAMERA] 13 - 16
DO NOT RECORD

1. Click **CONTROL** → **TIMER RECORDING** → **DATE TIMER**

DATE TIMER SETUP can be customized. After entering the special date, click the [SAVE] button.

1 Select the Program No..

2 Select the date to execute record.

3 Select the time to start/end record program.

4 Select the [REC SPEED], [REC QUALITY], [AUDIO REC] and [EXEC] for each camera channel.

5 Click [SAVE].

Notes

- A maximum of 16 timer programs can be set for a specific recording mode in the Date Timer Setup.
- Click [RESET] to restore the value previously saved.
- Click [SAVE] to save settings at VR-716.
- Click [RESET] when settings are incorrectly entered.
- Upon clicking [SAVE], restoration of the original preset value will not be possible.

Updated Page: 29 / Sep 19:51:17

Programs for DATE TIMER can be deleted. Click the [DEL] button.

PROGRAM NO.	DATE(DD/MM)	PROGRAM NO.	DATE(DD/MM)
1	1/OCT	9	**/**
2	**/**	10	**/**
3	**/**	11	**/**
4	**/**	12	**/**
5	**/**	13	**/**
6	**/**	14	**/**
7	**/**	15	**/**
8	**/**	16	**/**

Program List for Date Timer.

CLOSE

Caution

- When all the "CAMERA" settings of a particular "BLOCK" in VR-716's "REC MODE" Menu are set to "OFF", the "FRAME RATE", "REC QUALITY" and "AUDIO REC" settings for that block cannot be altered.
- Refer to the notes related to Summer Time. (Page 116)

2. Set to the Program Timer Standby mode

Page 88 'Setting VR-716 to the Program Timer Standby Mode'

Setting VR-716 to the Program Timer Standby Mode

1. Click **CONTROL** → **TIMER RECORDING** → **TIMER MODE**

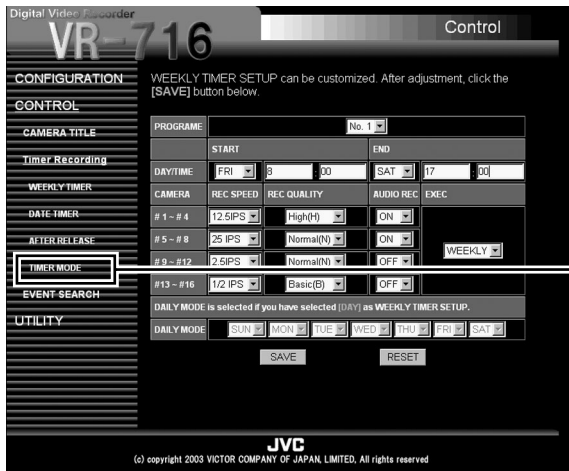

Note

- Timer mode cannot be executed if none of the Timer Program execution mode is activated and sensor setting is not performed.

2. Click **ON**

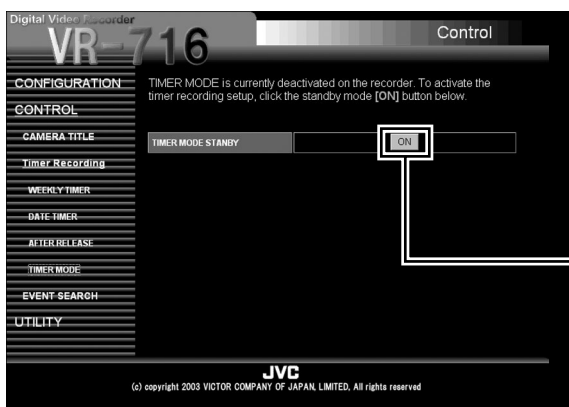

Notes

- Operations after setting the [TIMER MODE] to [OFF] are reflected on the [Release Timer operation] screen.
Page 88
- Alteration of settings and termination of recording related to [Release Timer operation] is not possible via the Web browser.
Page 54

3. To undo the Timer Standby mode, click **OFF**

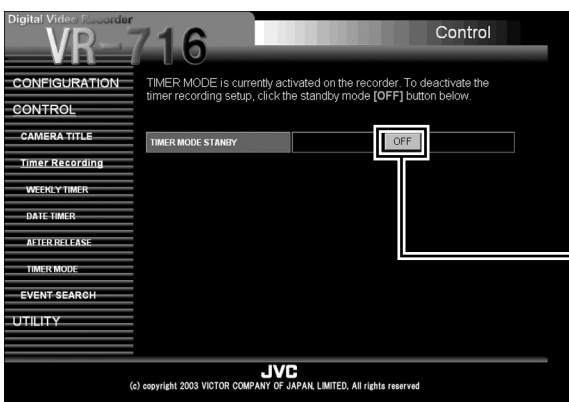

Caution

- The [OFF] button is displayed when the [TIMER STANDBY MODE] is activated. Double-check the [Release Timer operation] before using.

Checking Recording Operation After Release Timer is Executed

1. Click **CONTROL** → **TIMER RECORDING** → **AFTER RELEASE**

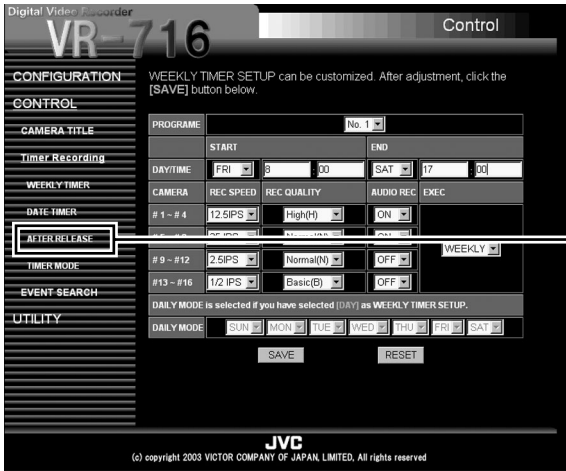

① Click [AFTER RELEASE].

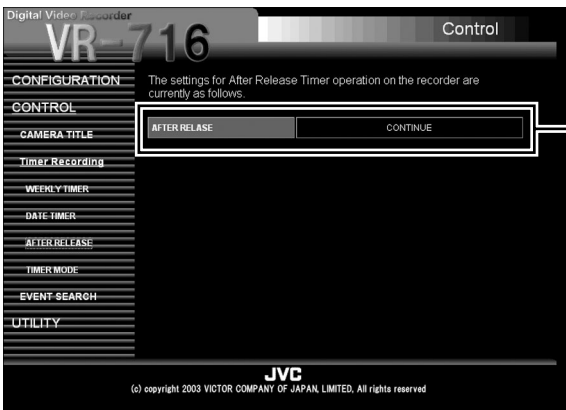

② Current status of the [Release Timer operation] is displayed. (Example) [AFTER RELEASE]: [CONTINUE]

Note

- Release the Timer mode at VR-716. Select one of the 3 operations below after Timer mode is released:

[CONTINUE]:

Recording will continue when Timer Recording is currently executed.

[STOP]:

Switches to the Stop mode regardless of whether Timer Recording is currently executed.

[NORMAL REC]:

Switches to the Normal Recording mode regardless of whether Timer Recording is currently executed.

▼ Operation after Release Timer: [STOP]

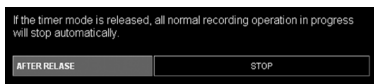

If the timer mode is released, all normal recording operation in progress will stop automatically.

▼ Operation after Release Timer: [NORMAL REC]

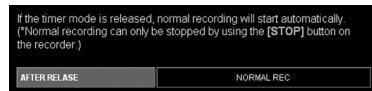

If the timer mode is released, normal recording will start automatically. (*Normal recording can only be stopped by using the [STOP] button on the recorder.)

Caution

- Release Timer operation settings can only be viewed at the Web browser. Alteration is not possible.

Connecting to a PC – Routine Uses of the Web Browser – (continued)

Changing/Deleting Record Programs in the Program Timer

■ [WEEKLY TIMER] Programs

1. Click **CONTROL** → **TIMER RECORDING** → **WEEKLY TIMER**



■ To alter a record program. Click [UP] to change settings in the setting area of [WEEKLY TIMER SETUP].

■ To cancel a record program. Click [DEL].

Notes

- Upon clicking the [UP] button, current values will be displayed in the setting area of [WEEKLY TIMER SETUP].
- To execute/undo the Program Timer, click [UP] for each program and set [EXEC] in the setting area to [ON] / [OFF].
- When [DEL] is clicked, program settings will be discarded (cleared) in both Weekly and Date Timers and initial settings will be restored. To restore the values prior to clicking [DEL], perform the Timer Recording setting again.

■ [DATE TIMER] Programs

1. Click **CONTROL** → **TIMER RECORDING** → **DATE-TIMER**

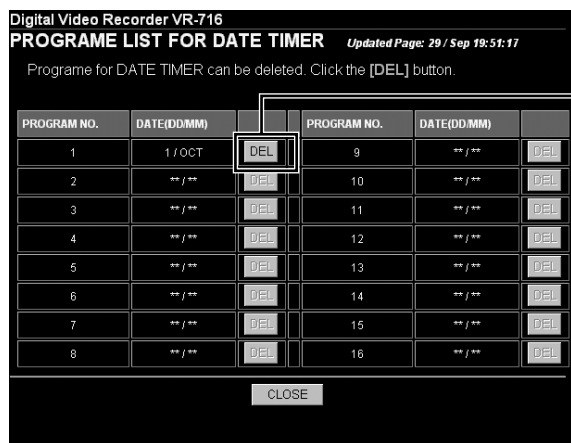

■ To cancel a record program. Click [DEL].

Searching Image According to Date/Time (Event Search)

Searching Alarm/Sensor recording

1. Click **CONTROL** → **EVENT SEARCH** → **ALARMSENSOR SEARCH**

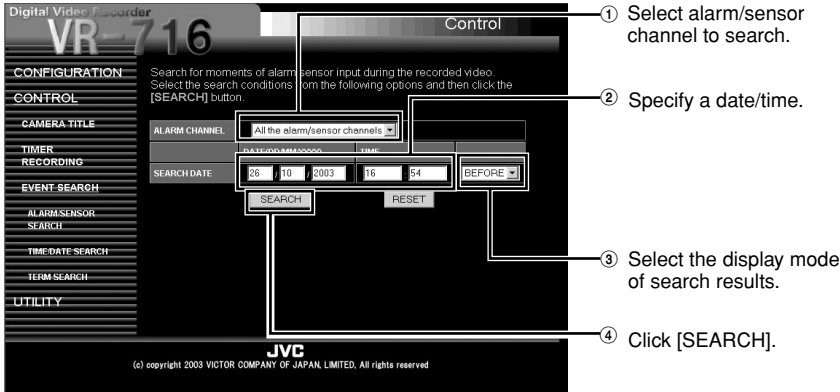

Digital Video Recorder VR-716
ALARMSENSOR SEARCH Updated Page: 20 / Sen: 10-57-20

ALARM NO	TYPE	CHANNEL	START	END	DURATION	
PreSen	P	1 2 - -	29/09/2003 10:55:49	29/09/2003 10:55:50	00:00:01	PLAY
000023	S	1 2 - -	29/09/2003 10:55:51	29/09/2003 10:55:53	00:00:02	PLAY
000022	A	1 2 - -	29/09/2003 10:55:41	29/09/2003 10:55:46	00:00:05	PLAY
000021	A	1 2 - -	29/09/2003 10:55:40	29/09/2003 10:55:40	00:00:00	PLAY
000020	A	1 2 - -	29/09/2003 10:55:32	29/09/2003 10:55:36	00:00:04	PLAY
000019	A	1 2 - -	29/09/2003 10:55:22	29/09/2003 10:55:27	00:00:05	PLAY
000018	S	1 2 - -	29/09/2003 10:55:11	29/09/2003 10:55:16	00:00:05	PLAY
000017	S	1 2 - -	29/09/2003 10:55:09	29/09/2003 10:55:11	00:00:02	PLAY
PreSen	P	1 2 - -	29/09/2003 10:55:00	29/09/2003 10:55:05	00:00:05	PLAY
000016	S	1 2 - -	29/09/2003 10:55:06	29/09/2003 10:55:08	00:00:02	PLAY
PreSen	P	1 2 - -	29/09/2003 10:54:49	29/09/2003 10:54:55	00:00:06	PLAY
000015	S	1 2 - -	29/09/2003 10:54:55	29/09/2003 10:54:59	00:00:04	PLAY
000014	S	1 2 - -	29/09/2003 10:54:44	29/09/2003 10:54:49	00:00:05	PLAY
PreSen	P	1 2 - -	29/09/2003 10:54:36	29/09/2003 10:54:40	00:00:04	PLAY
000013	S	1 2 - -	29/09/2003 10:54:42	29/09/2003 10:54:42	00:00:00	PLAY

Next 12 Lists

⑤ Search results are displayed.

⑥ Close the search results screen.

<Selection items for ①>

- From all the alarm/sensor channels
- ch 1 ~ ch 16 (specify by camera channel)

<Selection items for ③>

- [BEFORE]: Displays alarm events prior to the specified time in ⑤ starting from the most current event.
- [AFTER]: Displays alarm events after the specified time in ⑤ starting from the oldest event.

Notes

- A maximum of 15 events can be displayed during every search.
- When search result exceeds 15, a [Next 15 Events] button will be displayed below the list of search results. Click the [Next 15 Events] to display the next 15 results.
- Click the [Previous 15 Events] in the same way to display the previous results.
- Alarm search cannot be executed if alarm data is deleted at VR-716.

<Display details in ⑤>

- [ALARM NO]
- [TYPE]
 - [A] : Alarm Recording (Orange)
 - [S] : Sensor Recording (Orange)
 - (In the case of alarm/sensor recording by "MOTION DETECT", [M] is also displayed.)
 - [P] : Presensor Recording (Pink)
- [CHANNEL]: Indicating the number of camera for input. This will be displayed in white for normal recording, in orange for alarm/sensor recording, in pink for presensor recording and in red only for the channel which received alarm input among the alarm/sensor recording.
- [START]
- [END]
- [DURATION]

Caution

- Installation of the bundled application software [VR-716 Player] is required in order to view the playback images.
- Refer to the notes related to Summer Time. (Page 116)

2. Click the **PLAY** button for the event to be viewed

- This opens up the Viewer window and starts to playback images of the camera channel for which alarm/sensor recording is executed. (Page 99)

Connecting to a PC – Routine Uses of the Web Browser – (continued)

Searching Image According to Date/Time (Event Search)

Search By Date/Time

1. Click **CONTROL** → **EVENT SEARCH** → **TIME/DATE SEARCH**

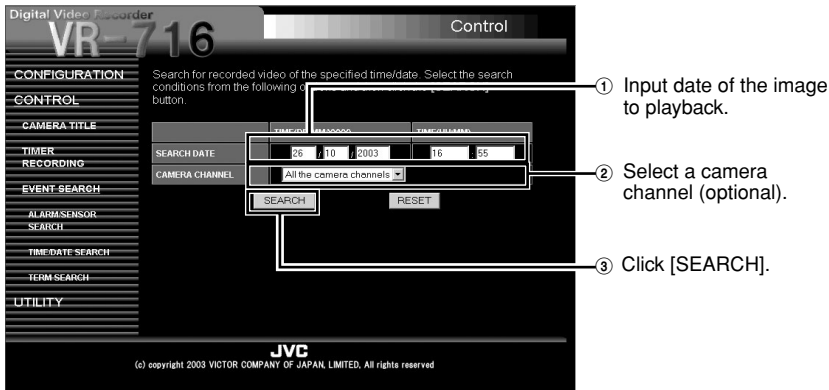

<Selection items for ②>

- From all the camera channels
- ch 1 ~ ch 16 (specify by camera channel)
- ch 1 ~ ch 4, ch 5 ~ ch 8, ch 9 ~ ch 12, ch 13 ~ ch 16 (specify by block)

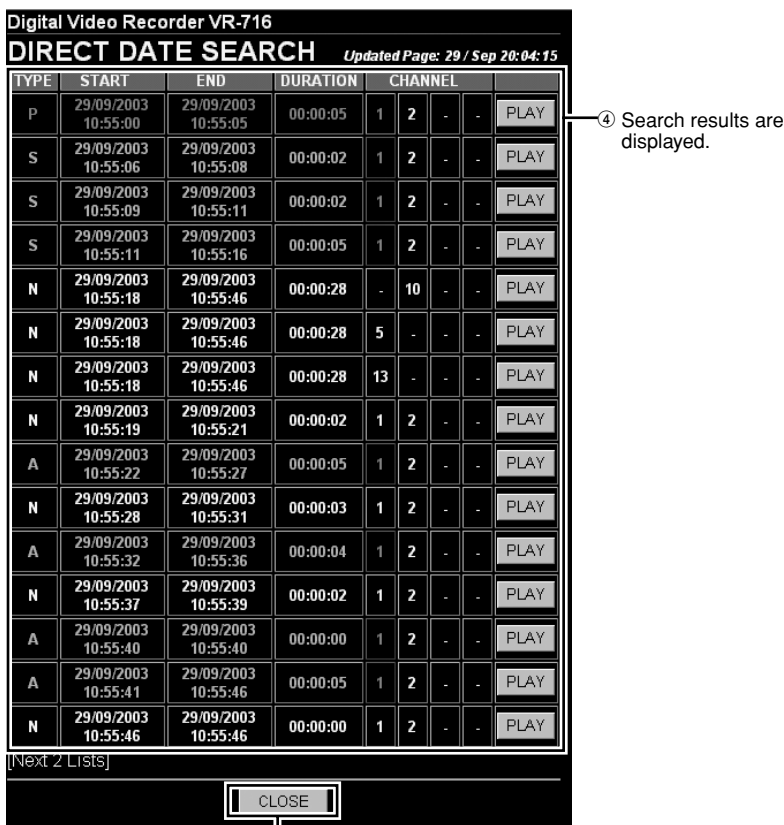

<Display details in ④>

- [TYPE]
 - [A] : Alarm Recording (Orange)
 - [S] : Sensor Recording (Orange)
 - [P] : Presensor Recording (Pink)
 - [N] : Normal Recording (White)
- [START]
- [END]
- [DURATION]
- [CHANNEL]

Caution

- Installation of the bundled application software [VR-716 Player] is required in order to view the playback images.
- Refer to the notes related to Summer Time. (Page 116)

2. To view a particular event, click the **PLAY** button for that event

- This opens up the Viewer window and starts playback of images from the specified date.

(Page 99)

Searching Image According to Date/Time (Event Search)

Search By Term

1. Click **CONTROL** → **EVENT SEARCH** → **TERM SEARCH**

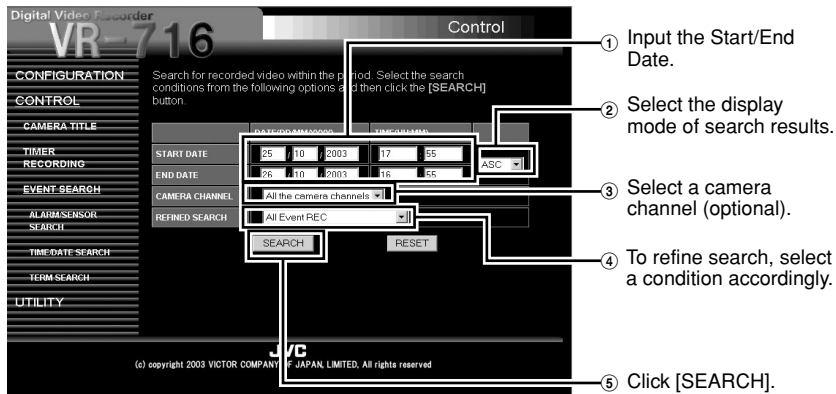

<Selection items for ②>

- [ASC]: Displays results from the oldest event.
- [DESC]: Displays results from the most current event.

<Selection items for ③>

- From all the camera channels
- ch 1 ~ ch 16 (specify by camera channel)
- ch 1 ~ ch 4, ch 5 ~ ch 8, ch 9 ~ ch 12, ch 13 ~ ch 16 (specify by block)

<Selection items for ④>

- [All Event REC] (Displays events of all recording data.)
- [All the alarm/sensor channels] (Displays only events of alarm/sensor recording.)
- [Only Normal REC] (Displays recording events except those of alarm/sensor recording.)

<Display details in ⑥>

- [TYPE]
 - [A] : Alarm Recording (Orange)
 - [S] : Sensor Recording (Orange)
 - [P] : Presensor Recording (Pink)
 - [N] : Normal Recording (White)
- [START]
- [END]
- [DURATION]
- [CHANNEL]

Notes

- A maximum of 15 search results can be displayed on the screen at a time.
- When search result exceeds 15, a [Next 15 Events] button will be displayed below the list of search results. Click the [Next 15 Events] to display the next 15 results.
- Click the [Previous 15 Events] in the same way to display the previous results.

Caution

- Installation of the bundled application software [VR-716 Player] is required in order to view the playback images.
- Refer to the notes related to Summer Time. (☞ Page 116)

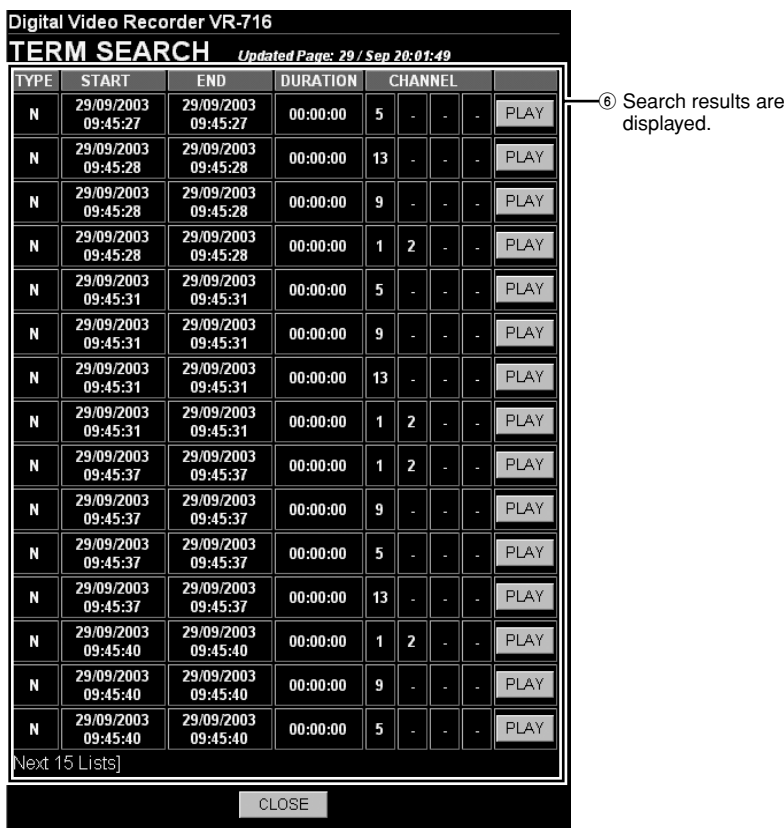

2. Click the **PLAY** button for the event to be viewed

- This opens up the Viewer window and starts playback. (☞ Page 100)

Connecting to a PC – Useful Browser Features –

Restricting Access to VR-716

When there are multiple users sharing a VR-716 in a network environment, authorization of access rights of varying degrees to individual users will be necessary in order to protect VR-716 settings or data.

At VR-716, the level of sharing can be specified according to the folders in which image files (event files) are stored.

1. Click

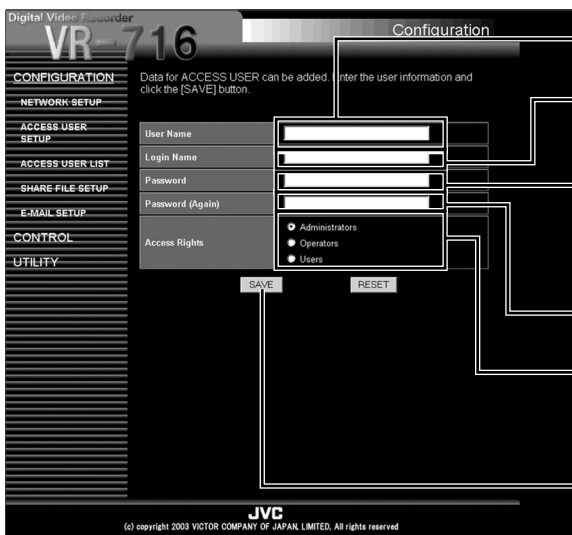

- ① Enter a user name (arbitrary).
- ② Enter user name as specified on Windows.
- ③ Enter password. Make sure not to forget the password.
- ④ Enter again to verify the password.
- ⑤ Select one of the Access Rights.
- ⑥ Click [SAVE].

Notes

- Refer to the Windows Help Menu to find out the user name set on Windows.
- The different levels of access rights are illustrated as follows:

	VR-716 setting	Timer setting	Event setting	Utility
[Administrators]	Yes	Yes	Yes	Yes
[Operators]	No	Yes	Yes	No
[Users]	No	No	Yes	No

- The 2 user names below are included in the factory settings:

	1	2
[Login Name]	[admin]	[guest]
[Password]	[vr-716]	[vr-716]
[Access Rights]	[Administrators]	[Operators]

Viewing the List of Registered Access Users

1. Click

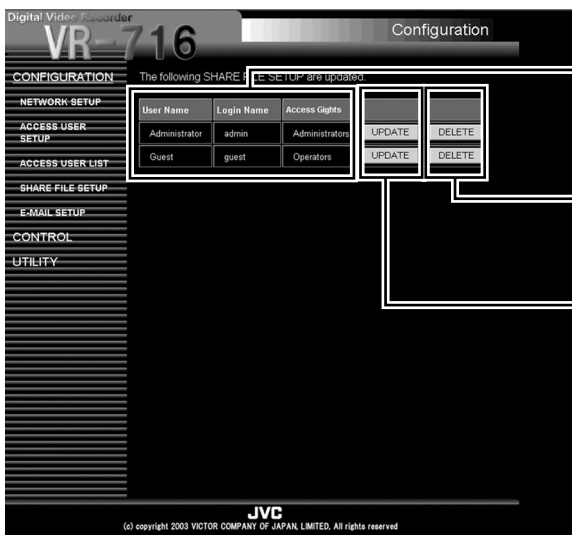

- ① The list of registered users is displayed.
- Click [DELETE] to clear data of the registered user.
- Click [UPDATE] to alter data of the registered user.

Caution

- When alteration is made to the registered Access User, ensure to perform account registration on Windows with the same user name and password. Refer to Windows Help Menu for the registration procedure of user accounts.
- If the current Administrators' rights password is forgotten, restoration by the user will not be possible. (Page 107)

Restricting Access to Recorded Image Files at VR-716

When there are multiple users sharing a VR-716 in a network environment, authorization of access rights of varying degrees to individual users will be necessary in order to protect VR-716 settings or file.

At VR-716, the level of sharing can be specified according to the folders in which image files (event files) are stored.

1. Click **CONFIGURATION** → **SHARE FILE SETUP**

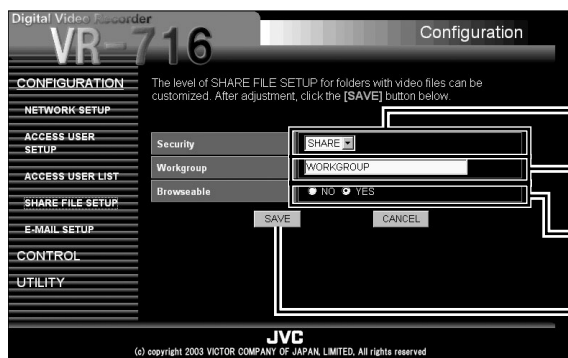

- ① Select [Security].
- ② Enter the [Workgroup] name registered with LAN.
- ③ A list of image data will be displayed when [YES] is selected.
- ④ Click [SAVE].

<Selection items for ①>

- [SHARE]:
Verifies only passwords that are registered in the Access User Setup (☞ Page 94).
- [USER]:
Verifies both user name and password.

Note

- Factory settings:

[Security]	: [SHARE]
[Workgroup]	: [WORKGROUP]
[Browseable]	: [YES]

Caution

- When access rights are altered during playback of image files, reboot of Windows will be required.
 ☞ Page 110 'Browsing Function'

■ The [Security] and [Browseable] settings combine to yield 4 selectable levels of security.

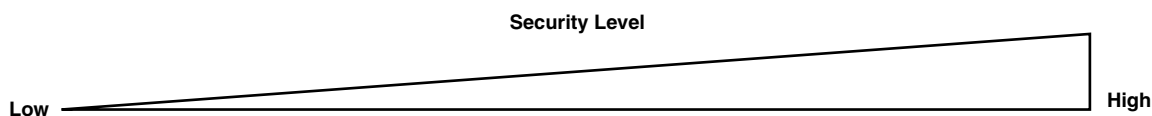

[Security]	[SHARE]	[USER]	[USER]	[USER]
[Browseable]	[YES]	[NO]	[YES]	[NO]
	Verifies [Login Name] and [Password] of registered users of VR-716. Unregistered users can gain access using [guest] and <i>no password</i> . The list of image files can also be viewed on other PCs within the same network.	Verifies [Login Name] and [Password] of registered users of VR-716. Unregistered users can gain access using [guest] and <i>no password</i> . The list of image files cannot be viewed on other PCs.	Verifies [Login Name] and [Password] of registered users of VR-716. The list of image files can also be viewed on other PCs within the same network.	Verifies [Login Name] and [Password] of registered users of VR-716. The list of image files cannot be viewed on other PCs.

Connecting to a PC – Useful Browser Features – (continued)

Changing Network Settings of VR-716 from PC

Details in the “NETWORK” Menu of VR-716 can be altered via operation on a Web browser.

1. Click **CONFIGURATION** → **NETWORK SETUP**

- ① Select the method of IP address setting.
 - [Static]: DHCP server not used.
 - [DHCP]: Uses DHCP server.
 - [None]: Prohibits all network connections.
- ② Enter the name used to denote your PC in the network environment.
- ③ Enter the domain name.
- ④ Enter the [IP Address], [Subnet Mask], [Default Gateway] and [Name Server].

⑤ Click [SAVE].

Caution

- When network settings of VR-716 are changed, network settings need to be altered accordingly at the PC. Consult the network administrator when making alterations.
- Upon changing network settings of VR-716, change the network settings at the PC as well, followed by restarting the Web browser.

Notes

- ◆ What is [Domain name]?
➤ Page 110
- ◆ What is [DHCP]?
➤ Page 110
- ◆ What is [Host name]?
➤ Page 110

Mail Notification Setting During Alarm/Sensor Input

In a network environment where use of a mail server (SMTP) is possible, mail notification setting can be performed at VR-716 to send out the alarm list during alarm/sensor input in the form of notification messages on a regular basis.

1. Click **CONFIGURATION** → **E-MAIL SETUP**

① Select a [Mode].

② Register the [Mail (SMTP) Server].

③ Select an [Interval] for sending out notification messages (5, 10, 15 or 30 minutes).

④ Register the mail address of the [To E-MAIL].

⑤ Register the mail address of the [From E-MAIL].

⑥ Click [SAVE].

<Selection items for ①>

- [None]: Disables the mail notification feature.
- [Alarm/Sensor]: Sends out mail notification during alarm/sensor input.

Notes

- When using the mail notification feature, perform settings described in page 96 'Network Settings' as well.
- To use the mail notification feature, the following information must be registered.
 - Mode
 - Mail (SMTP) Server (Enter the domain name.)
 - Sender's Mail Address
 - Minimum Mail Notification Interval
 - Receiver's Mail Address
- Notification mails can be sent out to multiple receivers by inserting [,] or a space between the receivers' mail addresses. (Maximum no. of input characters is 254)
- The following is registered as the [Subject:] in the factory settings: [Starting Alarm/Sensor REC!!] (Maximum no. of input characters is 32)
- [Normal] or [Short] can also be selected from the [List Form] as the mode of message display.

■ Upon setting, the mail notification feature can be checked to ensure that it is properly functioning.

- Clicking [SAVE] at the [E-MAIL SETUP] screen displays a confirmation screen.

① Click [TEST E-MAIL].

- Click [TEST E-MAIL] to issue a test mail. Check that this mail is received at the specified destination.
- When sending of notification fails due to errors in the settings or network, an error message will be displayed. Check the mail notification as well as network settings.

Caution

- Mail notification may fail depending on the authentication method at the mail server.
- Consult your network administrator on the mail server's settings.
- A complete alarm/sensor list may not be received depending on the maximum no. of characters a mobile can receive.
- Regardless of the interval setting of mail notification, the mail notification will be sent within 10 minutes from the first alarm/sensor input. It may take much time before data can be received depending on the network environment.

Connecting to a PC – Useful Browser Features – (continued)

- The notification mail received during alarm/sensor input will look as follows:

Mail Header

From: xxxxx@xxxxx.co.jp
To: xxxxx@xxxxx.co.jp
Subject: [Starting Alarm/Sensor REC!]

- The content in the [Subject] will be reflected.

Message (Normal List Format)

• ALARM/SENSOR NOTIFICATION

Host name: VR-716 [3rd factory]

The following alarm/sensor recording has been started:

01/08/2003(FRI) 20:15:15 A 3ch [INF.], 4ch [ENTRANCE]
01/08/2003(FRI) 20:15:17 S 9ch []
01/08/2003(FRI) 20:18:15 A 13ch [N. GATE], 14ch [], 16ch []

The End

- VR-716's host name will be reflected as the Host Name. The content registered at [Location Name] is also reflected in [].
- Lists data of alarm/sensor that are triggered within the specified minimum notification interval. The list contains 3 types of information as shown below:
 - Alarm/Sensor Activation Time
 - Recording Mode
 - A: Alarm recording
 - S: Sensor recording
 - Camera Channel [Camera Title]

Message (Short List Format)

RECORD NOTIF.

HOST. vr716
[3rd factory]

LIST DISPLAY
14/10/2003

clock: 19:39:18
Mode: A
CamCh: 3[INF.], 4[ENTRANCE]

clock: 19:39:39
Mode: S
CamCh: 6[]

clock: 19:39:45
Mode: A
CamCh: 13[N. GATE], 14[], 16[]

Note

- Only the language of the mail message changes in accordance with the "LANGUAGE SELECTION" in the main menu. (☞ page 25)

Caution

- There will be a few seconds difference between the alarm notification list and the actual time when recording starts.
- Refer to the notes related to Summer Time. (☞ Page 116)

Viewing Images of Event Search Results (Simple Viewer)

Installation of the bundled application software [VR-716 Player] will be required prior to using the Simple Viewer. Otherwise, it cannot be used to view event images of search results.

1. Search for an event

☞ Page 91 'Searching Image According to Date/Time'

2. Click the **PLAY** button for the event to be viewed

Displays the Viewer window.

Caution

- Playback using the Simple Viewer may stop or playback speed may be unstable as priority is given to recording or other forms of internal processing over outgoing processing to the network.
- Network playback of VR-716 via simultaneous connection by multiple PCs is not possible.
- There may be cases whereby recorded image file with audio may not be fully displayed.
- Refer to the notes related to Summer Time. (☞ Page 116)

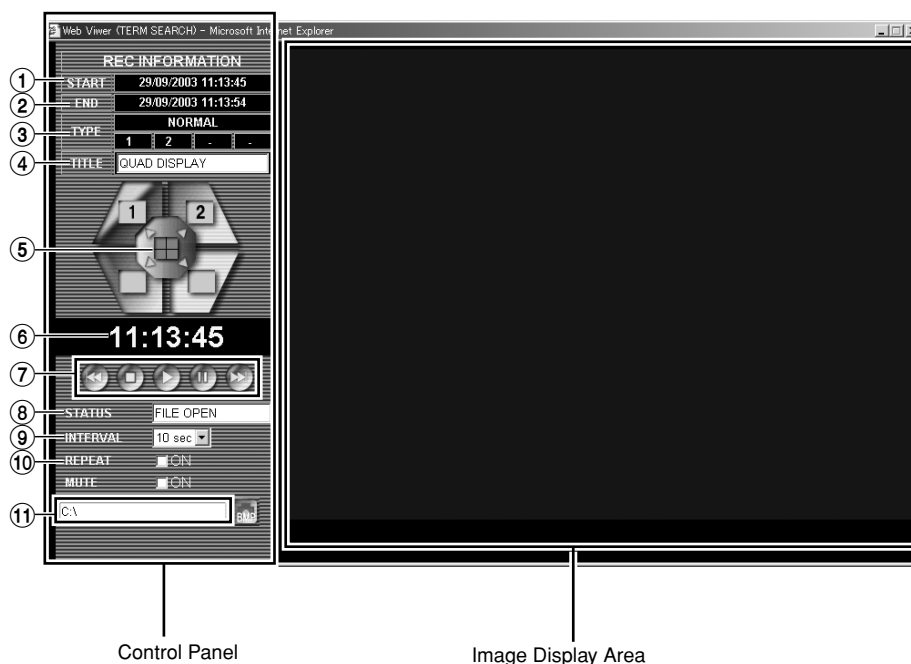

Names and Functions

- ① **[START]**
Displays the date/time recording started.
- ② **[END]**
Displays the date/time recording ended.
- ③ **[TYPE]**
Displays the mode of recording and the camera channels. This will be displayed in white for normal recording, in orange for alarm/sensor recording, in pink for presensor recording and in red when there is alarm input during alarm/sensor recording. (☞ See right diagram)

Recording Mode

[NORMAL]	Recording using the (●) button at VR-716.
[NORMAL (SPLIT)]	Splits up automatically in the Normal Recording mode during recording over extensive periods of time.
[PRESENSOR]	When "PRESENSOR REC" is set to "ON" at VR-716 .
[ALARM]	When recording mode is set to "ALARM" at VR-716.
[SENSOR]	When recording mode is set to "SENSOR" at VR-716.

Camera Channel

[-]: No input
1 ch ~ 16 ch (Multiple channels are displayed during simultaneous input)

Viewing Images of Event Search Results (Simple Viewer)

■ Functions (continued)

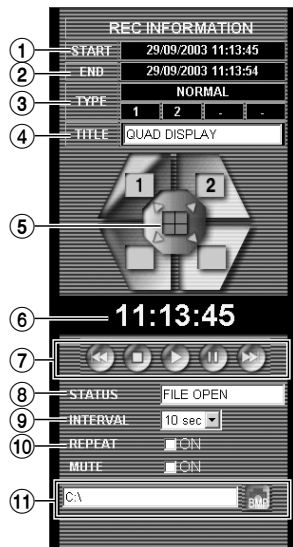

④ [TITLE]

Displays the registered camera title.

[NO TITLE]	When title is not registered.
[QUAD DISPLAY]	When displaying in quad picture.
[Registered Camera Title]	Title display according to the camera no..

⑤ Switching between quad picture and single picture modes.

(The Web Viewer automatically identifies screens in quad/single picture as well as the camera no..)

: Displays in single picture. (Displays each camera channel no.)

: Displays in quad picture.

⑥ Displaying the time of playback images.

⑦ Control buttons for the recorded image files.

: Skip in the reverse direction according to the skip intervals.

: Stop playback and move to the top of the file.

: Start playback.

: Stop playback image temporarily.

: Skip in the forward direction according to the skip intervals.

Note

- If playback is started during continuous alarm recording, it will start to playback 2 seconds earlier than the starting time.

⑧ Displays the operational status of the Web Viewer.

[FILE OPEN]	Preparation for playback on Web Viewer is completed.
[ACCESS FAILED]	Preparation for playback on Web Viewer failed.
[TOP OF FILE]	Top of the file.
[END OF FILE]	End of the file.
[PLAY]	Currently in the Playback mode.
[PAUSE]	Currently in the Still mode.
[FWD SKIP]	Currently in the Skip mode.
[BACK SKIP]	Currently in the Reverse Skip mode.
[ERROR]	When internal error has occurred.

⑨ [INTERVAL] when using the Skip buttons. [Skip interval] that can be selected varies according to the frame rate of the image files.

※ Check the “REC QUALITY” and “FRAME RATE” at VR-716.

“FRAME RATE”	[INTERVAL]
[25 IPS] ~ [1 IPS]	[1 sec], [5 sec], [10 sec], [20 sec], [30 sec], [1 min], [5 min], [10 min], [15 min], [30 min] and [1 hour]
[1/2 IPS]	[2 sec], [4 sec], [10 sec], [20 sec], [30 sec], [1 min], [5 min], [10 min], [15 min], [30 min] and [1 hour]
[1/6 IPS]	[5 sec], [10 sec], [20 sec], [30 sec], [1 min], [5 min], [10 min], [15 min], [30 min] and [1 hour]
[1/12 IPS]	[10 sec], [20 sec], [30 sec], [1 min], [5 min], [10 min], [15 min], [30 min] and [1 hour]

⑩ ON/OFF switches for [REPEAT] and [MUTE]. Tick the to turn [ON] the switch.

The [MUTE] box cannot be ticked for image files without audio sound. (Displayed as OFF all the time)

⑪ Click to save the still image in BMP format to the specified directory (default directory is C:\). The time stamp of the recorded image will be used automatically as the file name of the still image as shown below:

Example) n1_20030224_091035001.bmp	
	Denotes hh mm ss msec (hour, minute, second, millisecond).
	Denotes YY MM DD (year, month, day).
	Denotes recording mode and block no..
	(a: Alarm Recording s: Sensor/ Presensor Recording n: Normal Recording)
The example shown indicates that images are recorded in the Normal Recording mode at Block 1 (Cameras 1-4) on 24/02/2003 at 09:10:35.	

※ The still image can also be saved to the Desktop by leaving the directory field empty and pressing [Enter] during playback.

Saving VR-716 Settings to a File

1. Click **UTILITY** → **DOWNLOAD**

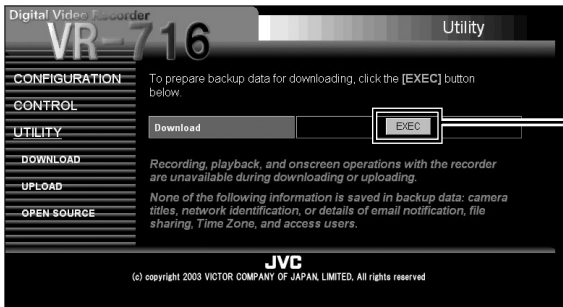

① Press [EXEC] to create a backup data for downloading.

2. Wait for a while for the backup data to be created

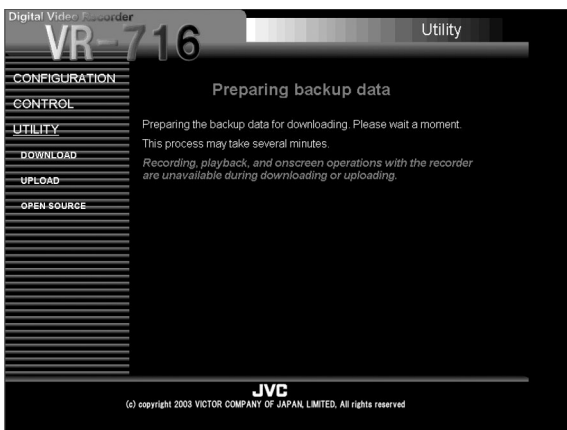

② Operational status will be checked automatically at VR-716 in intervals of a few seconds.

3. After backup data is created, click [SAVE] to save the data file to the PC



③ Click [SAVE].

Caution

- As this is a utility feature, ensure to stop all operation at VR-716 when executing.
- Execution of utility features can only be performed by users with Administrator rights.
- During downloading, recording, playback and onscreen operation at VR-716 will be disabled.
- Download will take a few minutes to complete.
- The information related to camera title, TIME ZONE, network, mail notification, file sharing and access user will not be stored into the backup data.

Notes

- If backup data previously created is saved at VR-716, the download screen will be displayed together.
- If backup data that is previously created exists, this will be overwritten by the new data.
- The following messages will be displayed onscreen during download:

NOW PROCESSING	[NOW READING THE DATA]
SUCCEEDED	[DOWNLOAD HAS BEEN COMPLETED] ※
FAILED	[DOWNLOAD HAS FAILED] ※

※ Display for 5 seconds (blinking at approx. 1 sec interval) after download has been completed.

Note

- The information on the version no. of VR-716 main unit when the data is created as well as date/time created (DD/MM/YY hh:mm:ss) will be displayed on the [Backup data completed] screen.

Connecting to a PC – Useful Browser Features – (continued)

4. Click “Save”

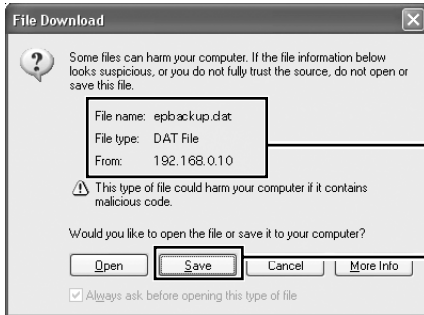

④ Check the data name and sender.

⑤ Click “Save”.

Caution

- As download is performed via the Web browser, a security message will be displayed.
- For security reasons, check that the downloaded data name is [epbackup.dat] and that the sender uses VR-716's IP address.

5. Specify a location on the PC for the data to be saved

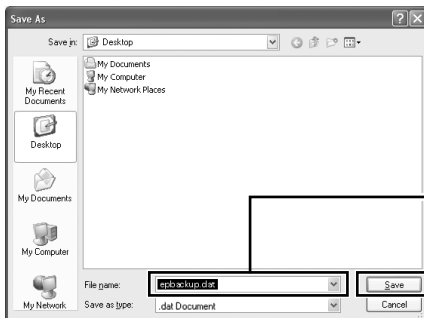

⑥ Specify the location for saving the [epbackup.dat] data.

⑦ Click “Save”.

6. Download completed

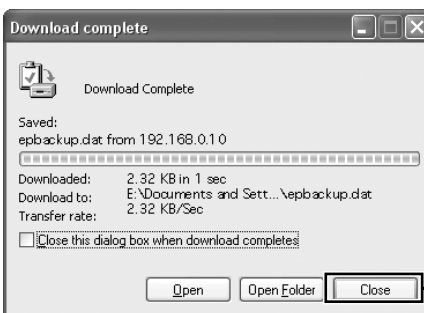

⑧ Click “Close” and check that the data has been saved to the designated location.

Uploading VR-716 Settings

1. Click **UTILITY** → **UPLOAD**

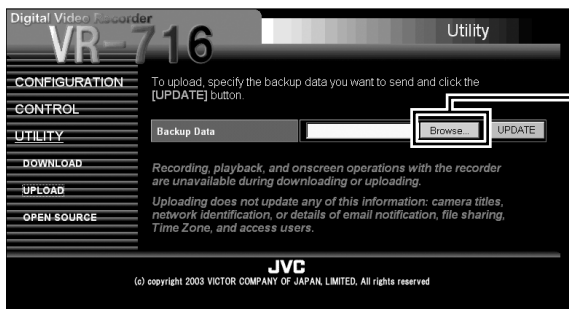

① Click [BROWSE] to specify a backup data file saved on the PC.

Caution

- As this is a utility feature, ensure to stop all operation at VR-716 when executing.
- Execution of utility features can only be performed by users with Administrator rights.
- During uploading, recording, playback and onscreen operation at VR-716 will be disabled.
- Upload will take a few minutes to complete.
- For uploading, the information related to camera title, TIME ZONE, network, mail notification, file sharing and access user will not be updated.

Notes

- If backup data previously created is saved at VR-716, the download screen will be displayed together.
- If backup data that is previously created exists, this will be overwritten by the new data.
- The following messages will be displayed onscreen during upload:

NOW PROCESSING	[NOW WRITING THE DATA]
SUCCEEDED	[UPLOADING HAS BEEN COMPLETED]
FAILED	[UPLOADING HAS FAILED]

Display for 5 seconds (blinking at approx. 1 sec interval) after upload has been completed.

2. Specify the backup data file to upload from the PC

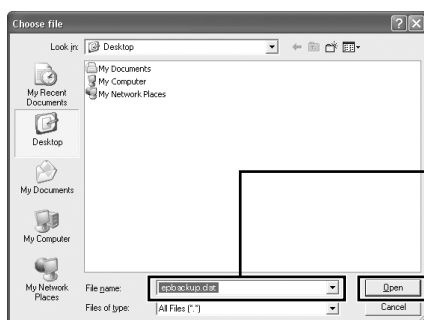

② Enter the file name for uploading.

③ Next, click the "Open" button.

3. Click [UPDATE] after specifying a backup data file

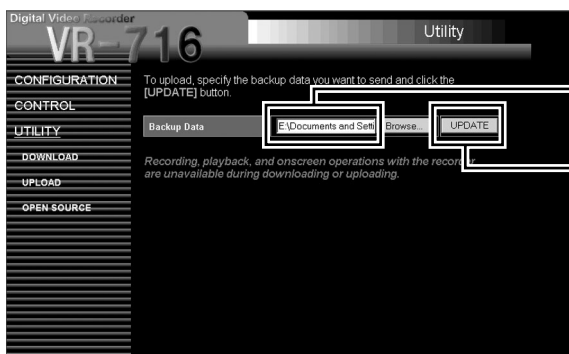

④ Check that the specified backup data is listed.

⑤ Click the [UPDATE] button.

4. Click [EXEC]

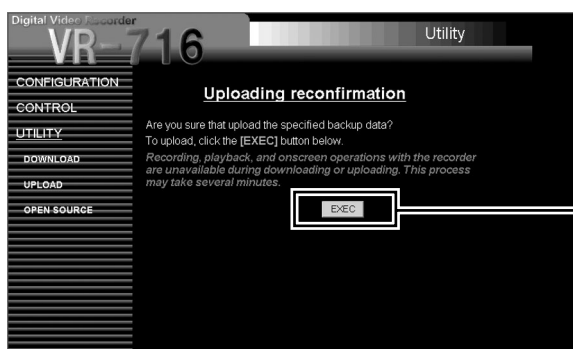

⑥ Click the [EXEC] button.

Connecting to a PC – Useful Browser Features – (continued)

5. Wait for a while when uploading to EEPROM (processing may take a few minutes)

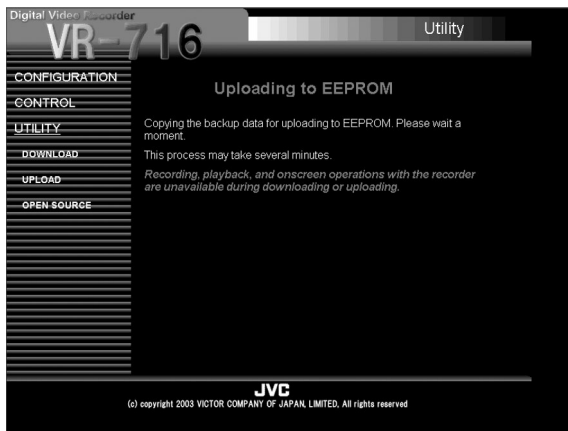

Caution

- Be careful as error may occur if the power is turned off during upload to EEPROM.
- Uploading to EEPROM will take a few minutes.
- If power is turned off or disconnected during this operation, setting value of this unit are not guaranteed.

Note

- The backup data that is specified for uploading will contain information on the version no. as well as date/time created (DD/MM/YY hh:mm:ss).

6. After uploading is completed, display information of the uploaded backup data

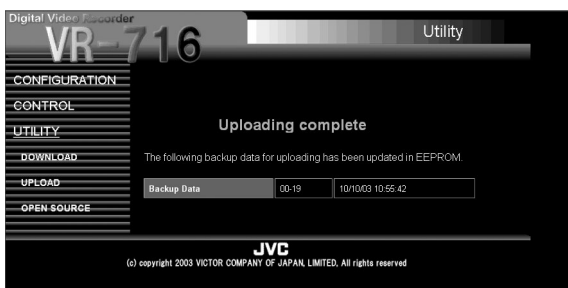

Information About Open Source Software

1. Click **UTILITY** → **OPEN SOURCE**



① Click [OPEN SOURCE].

Explanations

Troubleshooting

Problems Related to Error Code and Onscreen Display

Error Code	Onscreen Display	Cause	Action	Refer to Page
E-01 ※ 1 ※ 2	"E-01 DETECTED."	<ul style="list-style-type: none"> System restarted due to error in the functioning of hard disk. 	<ul style="list-style-type: none"> Consult your nearest JVC dealer. Continue the operation with the intact hard disk. The data in the disconnected hard disk will not be recovered if manual scan disk is executed. 	—
E-02	—	<ul style="list-style-type: none"> Error in the functioning of hard disk. (* Unable to start up) 	<ul style="list-style-type: none"> Consult your nearest JVC dealer. 	—
E-03 ※ 2	"NO VIDEO IN** INPUT (E-03)"	<ul style="list-style-type: none"> No video input signals. 	<ul style="list-style-type: none"> Stop operation and check the connection. Double-check settings in the "REC MODE" Menu. <ul style="list-style-type: none"> * Recording may fail if it is continued after the error message is displayed. Set the "CAMERA" setting to "OFF" in the "REC MODE" Menu or eliminate the cause of the error immediately. 	P14
E-04 ※2	"POWER OUTAGE LOG IS UPDATED."	<ul style="list-style-type: none"> Displayed when power outage occurs. 	<ul style="list-style-type: none"> This is not an error. Press the [CANCEL] button to clear the message. 	P71
E-05 ※ 1 ※ 2	"E-05 DETECTED."	<ul style="list-style-type: none"> Error in the fan motor. 	<ul style="list-style-type: none"> Consult your nearest JVC dealer. 	—
E-06 ※ 1 ※ 2	"E-06 DETECTED."	<ul style="list-style-type: none"> EEPROM error. 	<ul style="list-style-type: none"> If this error occurs due to alteration of menu setting, turn the equipment off/on and check the setting. If this error keeps occurring due to alteration of menu setting or during operation, consult your nearest JVC dealer. 	—
E-07 ※ 1 ※ 2	"E-07 DETECTED."	<ul style="list-style-type: none"> Encoder error. 	<ul style="list-style-type: none"> Consult your nearest JVC dealer. 	—
E-08 ※ 1 ※ 2	"E-08 DETECTED."	<ul style="list-style-type: none"> Decoder error. 	<ul style="list-style-type: none"> Consult your nearest JVC dealer. 	—
E-09 ※ 1 ※ 2	"E-09 DETECTED."	<ul style="list-style-type: none"> Error at one of the built-in hard disk drives. 	<ul style="list-style-type: none"> This error is detected only during Mirroring Setting. Consult your nearest JVC dealer. 	—
—	"HARD-DISK CAPACITY IS VERY LITTLE"	<ul style="list-style-type: none"> Recordable space on the hard disk is running out. 	<ul style="list-style-type: none"> When hard disk space is about to run out, make changes accordingly such as formatting the hard disk or changing setting to Repeat Record mode. <ul style="list-style-type: none"> * All event record data will be deleted when formatting is executed. 	P58 P25
— ※ 1 ※ 3	"NO HARD-DISK REMAINING CAPACITY"	<ul style="list-style-type: none"> No space available on the hard disk for recording. 	<ul style="list-style-type: none"> Format the hard disk to create recording space or set Repeat REC to values other than "OFF". <ul style="list-style-type: none"> * All event record data will be deleted when formatting is executed. 	P58 P25
—	"MAINTENANCE PROCEEDING"	<ul style="list-style-type: none"> Self-diagnosis of VR-716 in progress. 	<ul style="list-style-type: none"> This is not an error. 	—

Error codes are displayed on the front display (☞ page 13) of VR-716.

※1: Buzzer will sound when error occurs.

※2: A signal will be output to [WARNING OUT] terminal when error occurs.

※3: When the hard disk is full, priority is given to this display even if trigger to start recording is received such as by pressing [REC] button or alarm input during playback. (Blinks for 5 seconds)

Explanations (continued)

Troubleshooting (continued)

Other Problems

Symptom	Cause	Action	Refer to Page
Power cannot be turned on.	<ul style="list-style-type: none"> Is the power cable properly connected? 	<ul style="list-style-type: none"> Plug the supplied power cable to the outlet. 	—
[REC] and [PLAY] buttons do not work.	<ul style="list-style-type: none"> Is the Operation Lock turned on? Is the [TIMER] indicator on? 	<ul style="list-style-type: none"> Turn off the Operation Lock Press the [TIMER] button to turn off the timer program. 	P5 P8, P12, P54
Playback image is not displayed on the monitor.	<ul style="list-style-type: none"> Is the monitor properly connected? Are there recorded images on the camera selected using the 'Camera Selection' buttons? 	<ul style="list-style-type: none"> Connect the monitor properly. Select a camera with recorded images. 	P14, P15 P32, P33
Unable to start program recording using the Program Timer	<ul style="list-style-type: none"> Is the date/time set? Is the [TIMER] indicator on? Is the timer program properly set? 	<ul style="list-style-type: none"> Check the date/time setting. Press the [TIMER] button to set to the Program Timer Standby mode. Double-check the record program of the Program Timer. 	P18 P46~P54
Menu screen is not displayed.	<ul style="list-style-type: none"> Is the [TIMER] indicator on? Is the Operation Lock turned on? 	<ul style="list-style-type: none"> Press the [TIMER] button to turn off the timer program. Turn off the Operation Lock 	P8, P12, P54 P5
No onscreen display of date/time and title.	<ul style="list-style-type: none"> Are the items set to "OFF" in the "ONSCREEN MODE" Menu? 	<ul style="list-style-type: none"> Set items in the "ONSCREEN MODE" Menu to "ON" accordingly to enable them to be displayed onscreen. 	P19
Date/Time is not recorded.	<ul style="list-style-type: none"> Is the date/time properly set? 	<ul style="list-style-type: none"> Set the date/time. 	P18
[TIMER] indicator blinks.	<ul style="list-style-type: none"> Either the Program Timer is not programmed, or there is no record program that can be executed. Is there sufficient hard disk space? 	<ul style="list-style-type: none"> Double-check the record program of the Program Timer. Format the hard disk to create recording space or set Repeat REC to values other than "OFF". 	P46~P54 P58
Unable to play back audio sound.	<ul style="list-style-type: none"> Was the "AUDIO REC" item in the "REC MODE" menu set to "ON" during recording? 	<ul style="list-style-type: none"> Execute recording with the "AUDIO REC" item in the "REC MODE" menu set to "ON". ※ Audio recording is disabled when recording is executed with the "FRAME RATE" in the "REC MODE" Menu set to "1/6 IPS" (1 image per 6 seconds) or "1/12 IPS" (1 image per 12 seconds). 	P24
Unable to execute Skip Jump or Direct Jump	<ul style="list-style-type: none"> Is the date/time properly set? Is the Jump setting correct? 	<ul style="list-style-type: none"> Set the date/time. Perform the Jump setting accordingly. 	P18 P40~P43
All the LEDs of camera light up in red.	<ul style="list-style-type: none"> System error occurred. 	<ul style="list-style-type: none"> Disconnect and connect the power cord. 	—

Troubleshooting on Use of Browsers

Symptom	Cause	Action
[Operation Locked: (5XX1)] is displayed.	Operation of VR-716 via the network is prohibited.	Perform operation via the Web browser after stopping or ending all operations on VR-716.
[Normal Recording in Progress: (5XX2)] is displayed.	Normal recording is executed at VR-716.	
[Timer Recording in Progress: (5XX3)] is displayed.	Timer recording using the Program Timer is executed at VR-716.	
[Timer Sensor Recording in Progress: (5XX4)] is displayed.	Sensor recording is executed while in the Timer Recording mode at VR-716.	
[Alarm Recording in Progress: (5XX5)] is displayed.	Alarm recording is executed at VR-716.	
[Sensor Recording: (5XX6)] is displayed.	Sensor recording is executed at VR-716.	
[Onscreen/Menu Control: (5XX7)] is displayed.	Onscreen/Menu displayed at VR-716.	
[Timer Mode Standby: (5XX8)] is displayed.	Program Timer is in the Standby mode.	
[Video Playback in Progress: (5XX9)] is displayed.	VR-716 is currently playing back recorded images files.	
Unable to gain access by entering the specified URL at the browser.	Local address is being set.	Disable the use of proxy servers in the "Internet Options" Menu of the Web browser.
[Warning: Disable JavaScript in your web browser] is displayed.	JavaScript is prohibited on the Web browser currently used.	Alter the security level in the "Internet Options" Menu of the Web browser.
[Authorization Required] is displayed.	User Name and password verification during access to VR-716 failed.	Access VR-716 again and enter the correct user name and password.
User name and password are requested when [CONFIGURATION] and [TIMER RECORDING] are selected.	The current access rights is of a different level. (Page 94)	Login by entering a registered user name and password with a higher level of access rights.
Password for Administrator rights forgotten and menu screen for Web browser operation cannot be displayed.	Clients should manage important information such as passwords.	Deactivation of password that involves security issue will be treated as repair. Please consult your nearest JVC dealer.
[Timer Mode Standby cannot be activated] is displayed.	There is no timer program in the Weekly Timer or Date Timer to be executed.	Double-check settings of Weekly Timer and Date Timer.
VR-716 is currently in the Normal Recording mode after the timer is released and operation via the Web browser is not possible.	[AFTER RELEASE] setting at VR-716 is set to "NORMAL REC", hence recording starts in the Normal Recording mode when the timer is released.	Recording cannot be stopped via the Web browser. Press the [STOP] at VR-716 to stop recording.
Daily mode in the Weekly Timer cannot be selected.	The starting day of the selected no. in the Weekly Timer is not set to [DAY].	In the Program List for Weekly Timer, click the [UP] button of the program for which the starting day is set as [DAY]. Set this to the Daily mode.
New programs cannot be added to the Weekly Timer/Date Timer	A maximum of 8 and 16 programs are allowed in the Weekly Timer and Date Timer respectively.	To add new programs, do so using the [UP] and [DEL] buttons in the Program List.
[***: (4xx)] is displayed. [***: (xxxx)] is displayed.	Processing of setting request from the Web browser failed.	Select the menu item using the Menu button and resend request, or refresh the URL and perform operation via the Web browser again.
[SYSTEM ERROR (E_xx): ***] is displayed.	System error is detected at VR-716.	Check the operational status at VR-716.
Unable to view file list although the Browseable item in Share File Setup has been enabled.	Configuration between VR-716 and the PC client's network is incorrect.	Set the IP address of VR-716 and PC client to the same network domain as well as workgroup.

Explanations (continued)

Troubleshooting (continued)

Troubleshooting on Use of Web Browsers (continued)

Perform authentication for the PC if the following symptoms are observed.

- [Browseable] has been enabled but files cannot be viewed at the Explorer.
- When playback of event images is executed, the following message is displayed and playback fails.

The specified file \\192.168.0.10\normal_h2\n1_030110_18023600.mpg (example) cannot be opened. User has no access rights to the shared folder, or connection to the folder is fully occupied and access is not possible.

<Authentication Procedure>

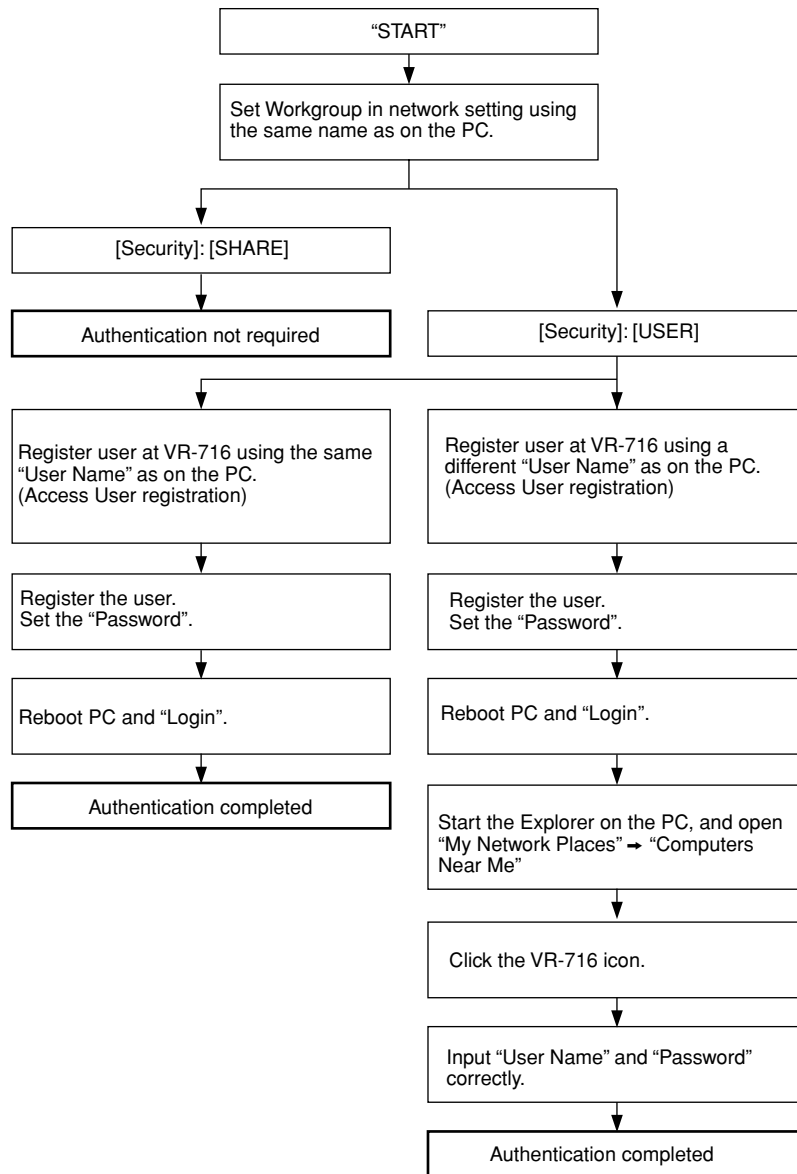

Upon authentication, access to and playing back recorded image files, or displaying recorded image files using the Explorer when [Browseable] is enabled are possible. Once authentication is completed, this will be valid until changes are made to the user name or authentication method.

- ※ If access to image files still fails after performing the above procedure, turn off the power of the PC in use and restart the PC.
- ※ Check the OS of the PC in use if the above error message continues to appear after authentication is performed. (Page 74)

■ Other Messages

Displayed Message	Cause	Action
[VR-716 Player] is not installed in this PC or [VR-716 Player] is active and execution is not possible.	Either the [VR-716 Player] application software is not installed or both the [VR-716 Player] and Simple Viewer are launched.	If it is not installed, do so using the CD-ROM supplied. End [VR-716 Player] when both are launched.
The specified file [****] cannot be opened. User has no access rights to the shared folder, or connection to the folder is fully occupied and access is not possible.	The shared folder at VR-716 is currently accessed by other users (maximum 1 user) or authentication of the shared folder is not performed.	Perform authentication. (☞ Page 108 'Authentication Procedure') Access to the folder by the access user is enabled if the folder remains inactive for 1 minute or more.
Cannot read recorded image files. Check if the shared folder at VR-716 can be viewed.	The image file is currently being played back at VR-716, or error in occurred in reading the recorded image file due to heavy network traffic.	Check whether the shared folder can be viewed via the network after playback at VR-716 has stopped. Restart the Web browser if the folder can be viewed but connection cannot be established.
<ul style="list-style-type: none"> • File format not supported. File cannot be opened. • Error occurred. • Playback is not possible due to insufficient memory. • Exception handling occurred. 	ActiveX internal error has occurred.	Restart the Viewer window.

Explanations (continued)

Web Browser Glossary

Domain name	The network name for which the network-connected PC belongs to.
Host Name	Name of PC (or VR-716) on the network. The name of the PC connected to the network is managed by a database called DNS (Domain Name System). DNS links the IP address assigned to each PC with the domain names, and enables a user to specify a PC to access.
IP Address	<p>An identification number assigned to each PC connected to the network. This is used for communication between network devices.</p> <p>There are 2 types of IP address, namely Global IP Address and Local IP Address (Private IP Address).</p> <p>Global IP Address : Just as separate IP addresses are required on a network, this is also required for all PCs that are connected to the Internet throughout the world. Such an IP address is known as the Global IP Address and is usually assigned by the Internet service provider.</p> <p>Local IP Address : Separate IP addresses can be used freely within networks that are not connected to the Internet (eg. within a family or company). This is known as the Local IP Address.</p> <div style="text-align: center;"> <p>IP addresses assigned by the PC is converted by the DNS server into host names and domain names.</p> </div>
DHCP (Dynamic Host Control Protocol)	This is a method that automatically assigns IP addresses on the network. The DHCP server will automatically assign an IP address to a PC when it is connected to the network.
Subnet mask	A mechanism that manages a network by segmenting it into multiple virtual networks (subnets). Subnet mask is a 32-bit value that is used to define how many bits to be used within the IP address for identifying the subnet.
LAN (Local Area Network)	A network that is built within a comparatively confined area such as within a building, company or office.
Default Gateway	Hardware and software that are used mutually for the translation of different protocols during communication of a PC with one that does not belong to the same network. In Windows, setting of a default gateway is required when setting the IP address.
Protocol	A set of rules used for communication of PCs or devices via the network.
TCP/IP	Abbreviation for Transmission Control Protocol/Internet Protocol. This is 1 of the protocols used by the network.
Login	Refers to the commencement of use upon connection of a PC terminal to an online database or server.
Peer-to-Peer	A small-scale network that connects PCs on a peer level (1-to-1).
Workgroup	A group that is set up among a small number of PCs in a work unit to ease reference of data on other PCs. It will be difficult to manage if there are a few hundred Windows-based PCs that are sharing the same network. In this case, management by setting up workgroups will be necessary.
Browsing Function	A service that displays PCs within a workgroup or domain, or the list of resources.

Recording Mechanism

Normal Recording

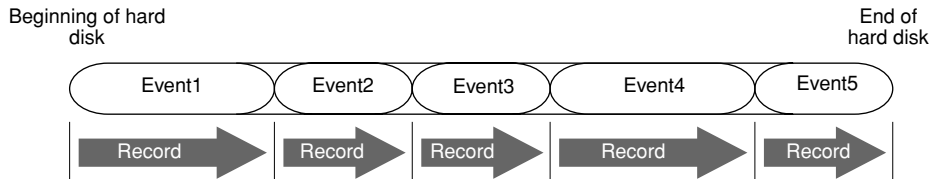

- Recording is executed from the start till the end of the hard disk during normal recording.
- A recording operation from the time it starts till it ends is referred to as an “Event”.
- Recording will stop when it reaches the end of the hard disk, and further recording will not be possible.
- When playback of events is executed as in the above diagram, the playback (audio and video) image will freeze for an instant at the boundaries of events.

Notes

- When the remaining hard disk space reaches below 1%, signals will be sent out from the [SERIES REC OUT] terminal on the rear panel. (☞ Page 61)

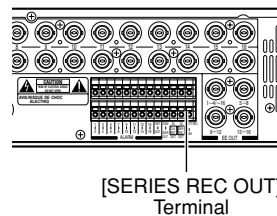

- ※ Set the menu during output of signals from the [SERIES REC OUT] terminal as follows.

OPERATION/EXT REC	
[OPERATION]	
1.RECOVERY REC	PRIOR STATE
2.REPEAT REC	OFF
3.LANGUAGE SELECTION	ENGLISH
4.WATER MARK	OFF
5.OPERATION LOCK	ALL
[EXT REC]	
1.EXT REC MODE	OFF
2.SERIES REC	ON

- Once a recording operation is stopped, it may take a few seconds before it can be started again.

Explanations (continued)

Recording Mechanism (continued)

Repeat Record

When recording reaches the end of the hard disk and there is no space left for recording, it returns to the start of the hard disk to overwrite old data. Such an operation is known as Repeat Record. Set this in the "REPEAT REC" item of the "OPERATION/EXT REC" Menu. Refer to 'Changing Menu Settings' on page 22.

■ When "ALARM LOCK" is selected

OPERATION/EXT REC	
[OPERATION]	
1.RECOVERY REC	PRIOR STATE
2.REPEAT REC	ALARM LOCK
3.LANGUAGE SELECTION	ENGLISH
4.WATER MARK	OFF
5.OPERATION LOCK	ALL
[EXT REC]	
1.EXT REC MODE	OFF
2.SERIES REC	OFF

- Executes repeat recording in the normal recording area (free space) excluding alarm recording data.

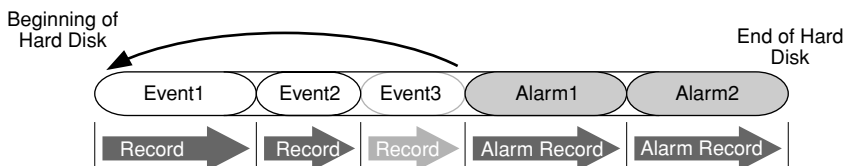

- Stops when there are too many alarm records and no space is left for the normal recording area.

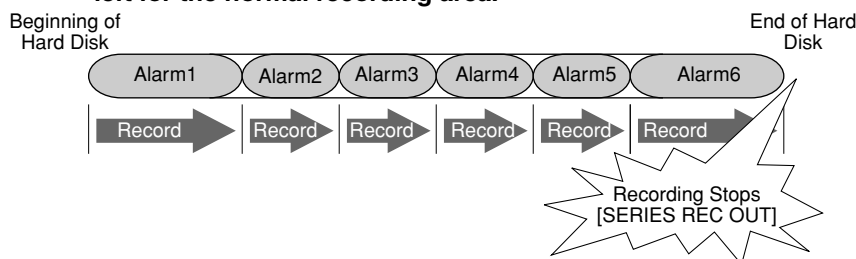

■ When "ALARM STOP" is selected

OPERATION/EXT REC	
[OPERATION]	
1.RECOVERY REC	PRIOR STATE
2.REPEAT REC	ALARM STOP
3.LANGUAGE SELECTION	ENGLISH
4.WATER MARK	OFF
5.OPERATION LOCK	ALL
[EXT REC]	
1.EXT REC MODE	OFF
2.SERIES REC	OFF

- When executing repeat recording without alarm recording.

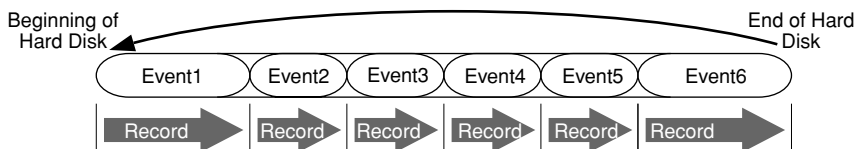

- Repeat recording cannot be executed when there is 1 or more alarm record.

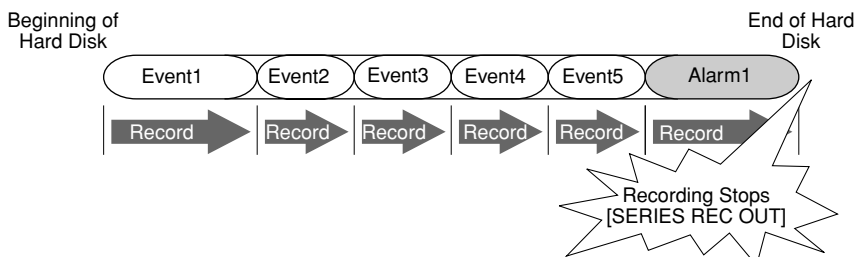

■ When "ALL" is selected

OPERATION/EXT REC	
[OPERATION]	
1.RECOVERY REC	PRIOR STATE
2.REPEAT REC	ALL
3.LANGUAGE SELECTION	ENGLISH
4.WATER MARK	OFF
5.OPERATION LOCK	ALL
[EXT REC]	
1.EXT REC MODE	OFF
2.SERIES REC	OFF

- Execute repeat recording regardless of alarm recording/normal recording area. Recording continues endlessly until [STOP] is pressed.

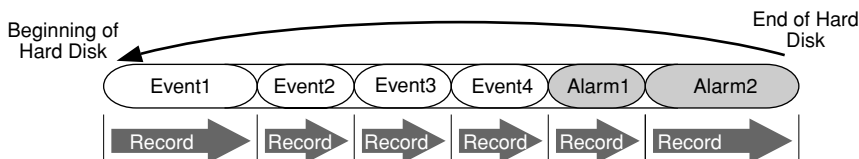

Caution

- The illustrations above on recording models are merely image diagrams and is different from the actual method of recording.
- Repeat Record overwrites from the oldest event. Data that has been overwritten will be totally deleted.

Presensor Recording

Presensor Recording is a feature that works hand-in-hand with Sensor Recording that starts recording automatically by tracing back to the time prior to the input of alarm signals. Set this in the "PRESENSOR REC" and "PRESENSOR REC DURATION" items of the "ALARM/SENSOR MODE" Menu. Refer to 'Changing Menu Settings' on page 22.

<Example>

Perform a 30-second presensor recording when in the Sensor Recording mode.

ALARM/SENSOR MODE	
1.BLOCK	1
2.REC MODE	ALARM
3.FRAME RATE	25 IPS
4.QUALITY	H
5.DURATION	180SEC
6.AUDIO REC	OFF
7.PRESENSOR REC	ON
8.PRESENSOR REC DURATION	30SEC
9.EXT INPUT OPERATING MODE	OFF
10.MOTION DETECT	OFF
11.MOTION DETECT SETTING	▶

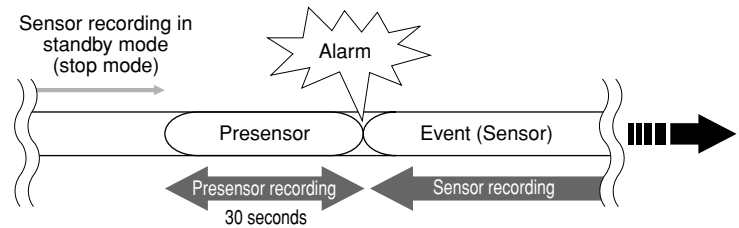

- Sensor recording starts at the same time when alarm signals are received. Upon the start of sensor recording, presensor recording will also start recording automatically for a 30-second interval.

<Presensor Recording Preset Values and Actual Recording Duration>

Settings	Actual Recording Duration
10 seconds	10 ~ 20 seconds
20 seconds	20 ~ 30 seconds
30 seconds	30 ~ 60 seconds

- A few frames will be left out between presensor and sensor recording.
- The portion recorded by presensor recording cannot be retrieved by alarm/sensor search.
- Presensor recording may be split up into 2 segments, depending on the input timing of the alarm signals. In this case, 2 presensor recording data will exist with respect to 1 sensor recording when search is performed on the Web. In addition, image may freeze for an instant at the interface of the 2 presensor records.

Explanations (continued)

Skip Jump

There are 3 types of Skip Jump, namely "TIME", "ALARM" and "EVENT", which can be specified in the search menu. Set this in the "SKIP MODE" item of the "SEARCH MENU". Refer to 'View Recorded Images in the Skip Mode' on page 43.

■ When "TIME" is selected

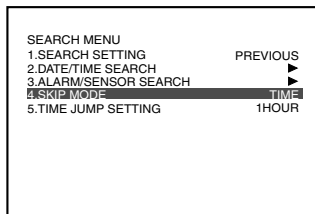

- Selecting "1 HOUR" for Time Jump Setting enables jumps in 1 hour intervals every time the [SKIP] button is pressed. Jumps to the closest position from the specified time onwards if the time to jump to is not found.

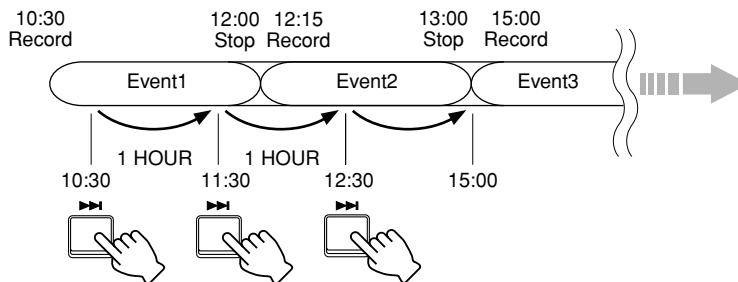

■ When "ALARM" is selected

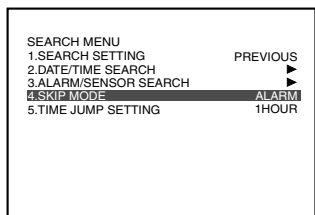

- Pressing [SKIP] each time enables a jump to the start position of alarm or sensor recording.

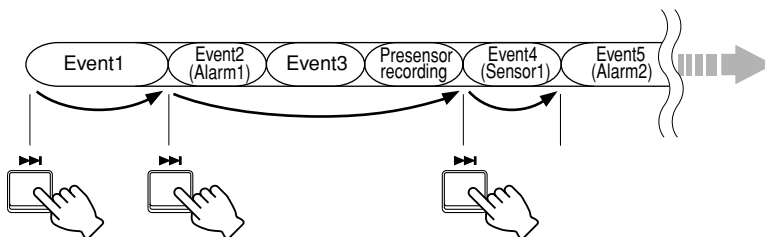

■ When "EVENT" is selected

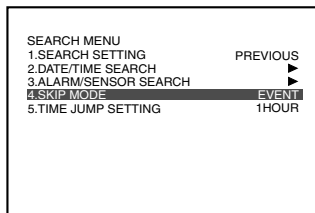

- Pressing [SKIP] each time enables a jump to the start position of recording (start of an event).

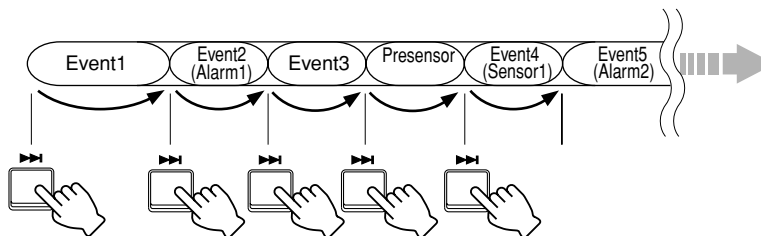

Note

- When there are too many events, it may take a while before Jump can be executed.

Recording Duration

Actual recording duration varies according to the input image as well as hard disk conditions. The table below is an example of detailed images (eg. in a casino) that illustrates the recording duration based on different modes of recording quality. Refer to the following table when recording detailed images.

Requirements: Upon setup of standard HDD (160 GB), 4 inputs per block

Recording Quality	Audio	Recording duration for Each Setting (Unit: Hour)									
		25 IPS	12.5 IPS	8.3 IPS	4.2 IPS	2.5 IPS	1.7 IPS	1 IPS	1/2 IPS	1/6 IPS	1/12IPS
HIGH	YES	9	16	20	32	40	47	50	95		
	NO	9	16	21	34	43	51	55	112	333	674
NORMAL	YES	12	21	27	38	49	58	108	180		
	NO	13	21	28	40	53	64	131	255	776	1493
BASIC	YES	19	29	37	47	59	70	129	210		
	NO	19	30	39	51	65	80	163	321	976	1888
LONG	YES	24	37	46	62	76	99	148	233		
	NO	25	40	50	69	87	118	195	377	1148	2177

Requirements: Upon setup of standard HDD (160 GB), 1 input per block

Recording Quality	Audio	Recording duration for Each Setting (Unit: Hour)									
		25 IPS	12.5 IPS	8.3 IPS	4.2 IPS	2.5 IPS	1.7 IPS	1 IPS	1/2IPS	1/6 IPS	1/12 IPS
HIGH	YES	9	17	23	33	41	48	51	95		
	NO	9	17	24	35	44	52	55	113	336	685
NORMAL	YES	12	21	29	46	55	68	176	269		
	NO	13	22	30	50	61	76	248	482	1463	2817
BASIC	YES	17	30	41	66	83	102	207	304		
	NO	17	32	44	74	96	122	312	603	1841	3510
LONG	YES	25	47	68	99	116	137	237	334		
	NO	26	51	77	118	144	177	386	737	2262	4283

* Recording duration may shorten by about 10% depending on the hard disk condition as well as type of image.

* When in the Repeat Record mode, recording will be deleted from the oldest data to create recording space when it is running out on the hard disk.

As such, recording duration may shorten by 10% as compared to the case when Repeat Record is set to "OFF".

* Recording duration may shorten due to wear and tear of the hard disk over time.

* When new hard disks are added, recording duration may slow down proportionately with the capacity of the new disk.

* Recording duration will reduce by half when the mirroring settings are activated. (Upon setup of a standard HDD)

RS-232C Connection

Control of VR-716 via external devices is possible by connecting VR-716 to the device via the [RS-232C] remote terminal on the rear panel.

For more details, refer to the [RS232CMANUAL.PDF] file located inside the [RS232CMANUAL] of the CD-ROM (VR-716 Player) that is supplied with VR-716.

Explanations (continued)

Notes related to Summer Time

VR-716 makes use of Time Zone to perform automatic switching for Summer Time and Winter Time.

- * The starting/ending time of Summer Time may differ from the actual time in your local area.

1. Changing the Time Zone

After changing the Time Zone during operation, make sure to format all the hard disks. If the hard disk is not formatted after changing the Time Zone, the following problems will arise.

- During playback on main unit, web browser or 716 player, the time display will be different from the actual recorded time.
- When performing file backup using 716 player, proper backup cannot be performed because the actual recorded time data is different from the time data specified by the player.
- The Alarm List will be different from the actual recorded time.
- The list for DVD-RAM copy will be different from the actual recorded time.

2. Changing the time

The time change by Summer Time will be performed automatically according to the setting value of the selected area in "TIME ZONE" setting. On the day when switching from Summer time to Winter time, there is a duplicated period where the same time will be reached twice. During this period, do not perform date/time setting (Menu/RS-232C/Front Display) and clock reset (Harmonica terminal/Front Panel).

3. Searching

For the Alarm List of the duplicated period of Summer/ Winter Time, the data will be displayed in the order of the actual recording time starts.

On the day when switching from Winter time to Summer time, there are certain times that do not exist. Do not perform "DATE/TIME SEARCH" for these times.

When searching the image recorded during the duplicated period on the day when switching from Summer time to Winter time, two images with the same time will exist. The operation of the various searches is shown below.

- 1) "DATE/TIME SEARCH" in the "SEARCH MENU" on the main unit
It will search for Winter Time. When searching for the "Summer Time" of the duplicated period, search using the jog/shuttle dial or [SKIP] buttons after performing "DATE/TIME SEARCH".
- 2) "ALARM SEARCH" in the "SEARCH MENU" on the main unit
It will search for Winter Time. When searching for the "Summer Time" of the duplicated period, search using the jog dial or [SKIP] buttons.
- 3) Search using the web browser or 716 player
It will search for Winter Time. When searching for the "Summer Time" of the duplicated period, specify the starting time at an earlier period before the duplicated period to search.

4. Playback

- 1) Playback using the main unit
When playing back the recording crossing the Summer and Winter Time, the playback time (date/time displayed on the OSD) of this portion may differ from the actual time.
- 2) Playback using the web browser or 716 player
When playing back the recording crossing the Summer and Winter Time, the ending time and the clock counter displayed may differ from the actual time.

5. Timer Programming

When the time changes from Summer to Winter or vice versa during TIMER REC, the recording will be divided and recorded as a different event at the changing point. In addition, a few seconds will not be recorded at the changing point.

On the day when switching from Summer time to Winter time, there is a duplicated period where the same time will be reached twice.

Do not set the starting/ending time within the duplicated period on the day when switching from summer time to winter time.

6. DVD-RAM COPY

- 1) Selecting the data list of the DVD-RAM
 - The specified starting time search of the Summer/Winter duplicated period will be searched as Winter Time.
 - For the data list of the DVD-RAM of Summer/Winter duplicated period, the data will be displayed in the order of the actual recording start time.
 - On the day when switching from Winter Time to Summer Time, there are certain times that do not exist. Do not perform specified starting time search for these times.
- 2) Cutting of the DVD-RAM record
 - The starting/ending time of the data crossing the Summer and Winter cannot be changed. When copying, the original starting/ending time will be copied.

7. PC environment settings

When searching or playing back from the web browser, set the PC TIME ZONE setting to the same as the VR-716 "TIME ZONE" setting.

8. The alarm list for mail notification

- For the message content of the mail notification, the local time will be recorded.
- When duplicated times are recorded due to Summer Time, to differentiate the message recorded in Summer Time or Winter Time, check the time sent stated on the mail header.

Others

Specifications

<General>

Video compression	: MPEG-2 (Conformity)
Capacity	: 80 GB x 2
Interface	: Ultra Wide SCSI, RS-232C UPS, LAN
Power supply	: 220 V - 240 V \sim 50 Hz/60 Hz
Power consumption	: 0.5 A
Allowable operating temperature	: 5°C ~ 40°C
Allowable storage temperature	: -20°C ~ 60°C
Allowable operating humidity	: 30 % ~ 80 %
Mass	: Approx, 7.0 kg

<Video signal>

Video input	: 16 lines (supports asynchronous input)
Video output	: 16 lines (Through) Video output x 3 lines (Front x 1, rear x 2) Split EE output 4 lines
Line input	: 1.0 V (p-p), 75 Ω (BNC unbalanced)
Line output	: 1.0 V (p-p), 75 Ω (BNC unbalanced)
Number of effective pixels	: 720 x 576 (Maximum number when in full screen recording) : 360 x 288 (When recording in QUAD mode)

<Audio signal>

Audio input	: 1 line
Audio output	: 3 lines (Front x 1, rear x 2)
Line input level	: -8 dBs, 50 k Ω (Unbalanced)
Line output level	: -8 dBs, 1 k Ω (Unbalanced)
Frequency	: 100 Hz ~ 10 kHz
Audio compression	: 48 kHz sampling, MPEG 1 layer 2 conformity

<Accessories>

Instructions	x 1
Install manual	x 1
Power cord	x 2
Bracket (Rack Mount)	x 2
Screws (M4)	x 4
Screws (M5)	x 4
CD-ROM	x 1

<Appearance>

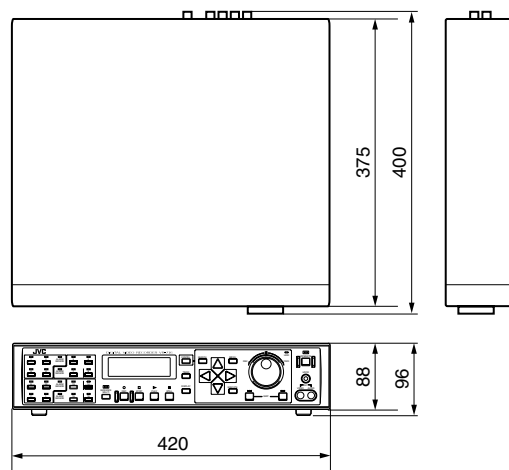

unit: mm

※ Specifications and appearance of this unit are subject to change for improvement without prior notice.



JVC® is a registered trademark owned by VICTOR COMPANY OF JAPAN, LTD.
JVC® is a registered trademark in Japan, the U.S.A., the U.K. and many other countries.
© 2003 VICTOR COMPANY OF JAPAN, LIMITED

LST0151-001A

Free Manuals Download Website

<http://myh66.com>

<http://usermanuals.us>

<http://www.somanuals.com>

<http://www.4manuals.cc>

<http://www.manual-lib.com>

<http://www.404manual.com>

<http://www.luxmanual.com>

<http://aubethermostatmanual.com>

Golf course search by state

<http://golfingnear.com>

Email search by domain

<http://emailbydomain.com>

Auto manuals search

<http://auto.somanuals.com>

TV manuals search

<http://tv.somanuals.com>