

JVC

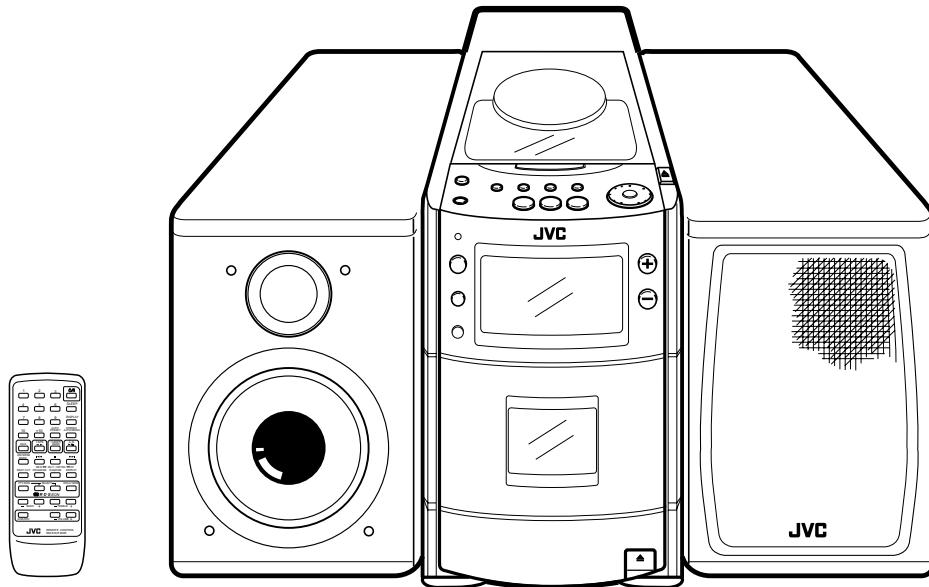

MICRO COMPONENT SYSTEM
MIKRO-KOMPONENTEN-SYSTEM
MICRO CHAINE
MIKRO KOMPONENTENSISTEEM
SISTEMA DE MICROCOMPONENTES
SISTEMA A MICROCOMPONENTI

UX-T300R



CD R-D-S EON

COMPACT
disc
DIGITAL AUDIO

INSTRUCTIONS
BEDIENUNGSANLEITUNG
MANUEL D'INSTRUCTIONS
GEBRUIKSAANWIJZING
MANUAL DE INSTRUCCIONES
ISTRUZIONI

For Customer Use:

Enter below the Model No. and Serial No. which are located either on the rear, bottom or side of the cabinet. Retain this information for future reference.

Model No.

Serial No.

LVT0027-005A

[E]

Warnings, Cautions and Others / Warnung, Achtung und sonstige Hinweise / Mises en garde, précautions et indications diverses / Waarschuwingen, voorzorgen en andere mededelingen / Avisos, precauciones y otras notas / Avvertenze e precauzioni da osservare

Caution — ϕ /I switch!

Disconnect the mains plug to shut the power off completely. The ϕ /I switch in any position does not disconnect the mains line. The power can be remote controlled.

Achtung — ϕ /I Schalter!

Den Netzstecker aus der Steckdose ziehen, um die Stromversorgung vollkommen zu unterbrechen. Der Schalter ϕ /I unterbricht in keiner Stellung die Stromversorgung vollkommen. Die Stromversorgung kann mit der Fernbedienung ein- und ausgeschaltet werden.

Attention — Commutateur ϕ /I!

Déconnecter la fiche de secteur pour couper complètement le courant. Le commutateur ϕ /I ne coupe jamais complètement la ligne de secteur, quelle que soit sa position. Le courant peut être télécommandé.

Voorzichtig — ϕ /I schakelaar!

Om de stroomtoevoer geheel uit te schakelen, trekt u de stekker uit het stopcontact. Anders zal er altijd een geringe hoeveelheid stroom naar het apparaat lopen, ongeacht de stand van de ϕ /I schakelaar. U kunt het apparaat ook met de afstandsbediening aan- en uitschakelen.

Precaución — Interruptor ϕ /I!

Desconectar el cable de alimentación para desactivar la alimentación totalmente. Cualquier que sea la posición de ajuste del interruptor ϕ /I, la alimentación no es cortada completamente. La alimentación puede ser controlada remotamente.

Attenzione — L'interruttore ϕ /I !

Disinserire la spina del cavo di alimentazione dalla presa della rete elettrica per staccare completamente l'alimentazione. L'interruttore ϕ /I in nessuna posizione stacca la linea di alimentazione elettrica principale. È possibile il controllo remoto dell'alimentazione.

Per l'Italia:

"Si dichiara che il questo prodotto di marca JVC è conforme alle prescrizioni del Decreto Ministeriale n.548 del 28/08/95 pubblicato sulla Gazzetta Ufficiale della Repubblica Italiana n.301 del 28/12/95."

CAUTION

To reduce the risk of electrical shocks, fire, etc.:

1. Do not remove screws, covers or cabinet.
2. Do not expose this appliance to rain or moisture.

ACHTUNG

Zur Verhinderung von elektrischen Schlägen, Brandgefahr, usw.:

1. Keine Schrauben lösen oder Abdeckungen entfernen und das Gehäuse nicht öffnen.
2. Dieses Gerät weder Regen noch Feuchtigkeit aussetzen.

ATTENTION

Afin d'éviter tout risque d'électrocution, d'incendie, etc.:

1. Ne pas enlever les vis ni les panneaux et ne pas ouvrir le coffret de l'appareil.
2. Ne pas exposer l'appareil à la pluie ni à l'humidité.

VOORZICHTIG

Ter vermindering van gevaar voor brand, elektrische schokken, enz.:

1. Verwijder geen schroeven, panelen of de behuizing.
2. Stel het toestel niet bloot aan regen of vocht.

PRECAUCIÓN

Para reducir riesgos de choques eléctricos, incendio, etc.:

1. No extraiga los tornillos, los cubiertas ni la caja.
2. No exponga este aparato a la lluvia o a la humedad.

ATTENZIONE

Per ridurre il rischio di shock elettrici, incendi, ecc.:

1. Non togliete viti, coperchi o la scatola.
2. Non esponete l'apparecchio alla pioggia e all'umidità.

Caution: Proper Ventilation

To avoid risk of electric shock and fire, and to prevent damage, locate the apparatus as follows:

- 1 Front:
 - No obstructions and open spacing.
- 2 Sides/ Top/ Back:
 - No obstructions should be placed in the areas shown by the dimensions below.
- 3 Bottom:
 - Place on the level surface. Maintain an adequate air path for ventilation by placing on a stand with a height of 10 cm or more.

Vorsicht: Ausreichende Belüftung

Zur Vermeidung von elektrischen Schlägen, Feuer und sonstigen Schäden sollte das Gerät unter folgenden Bedingungen aufgestellt werden:

- 1 Vorderseite:
 - Hindernisfrei und gut zugänglich.
- 2 Seiten- und Rückwände:
 - Hindernisfrei in allen gegebenen Abständen (s. Abbildung).
- 3 Unterseite:
 - Die Stellfläche muß absolut eben sein. Sorgen Sie für ausreichende Luftzufuhr durch Aufstellung auf einem Stand mit mindestens 10 cm Höhe.

Attention: Aération correcte

Pour prévenir tout risque de décharge électrique ou d'incendie et éviter toute détérioration, installez l'appareil de la manière suivante:

- 1 Avant:
 - Bien dégagé de tout objet.
- 2 Côtés/dessus/dessous:
 - Assurez-vous que rien ne bloque les espaces indiqués sur le schéma ci-dessous.
- 3 Dessous:
 - Posez l'appareil sur une surface plane et horizontale. Veillez à ce que sa ventilation correcte puisse se faire en le plaçant sur un support d'au moins dix centimètres de hauteur.

Voorzichtig: Goede ventilatie vereist

Om brand, elektrische schokken en beschadiging te voorkomen, moet u het toestel als volgt opstellen:

- 1 Voorkant:
 - Geen belemmeringen en voldoende ruimte.
- 2 Zijkanten/boven-/onderkant:
 - Geen belemmeringen plaatsen in de hieronder aangegeven zones.
- 3 Onderkant:
 - Op vlakke ondergrond plaatsen. Voldoende ventilatieruimte voorzien door het toestel op een onderstel met een hoogte van 10 cm of meer te plaatsen.

Precaucion: ventilación correcta

Para evitar el riesgo de descargas eléctricas e incendio y prevenir posibles daños, instale el equipo en un lugar que cumpla los siguientes requisitos:

- 1 Parte frontal:
 - Sin obstrucciones, espacio abierto.
- 2 Lados/parte superior/parte posterior:
 - No debe haber ninguna obstrucción en las áreas mostradas por las dimensiones de la siguiente figura.
- 3 Parte inferior:
 - Sitúe el equipo sobre una superficie nivelada. Mantenga un espacio adecuado para permitir el paso del aire y una correcta ventilación, situando el equipo sobre un soporte de 10 o más cm de altura.

Attenzione: Per una corretta ventilazione

Per prevenire il rischio di scosse elettriche e di incendio ed evitare possibili danni, collocare le apparecchiature nel modo seguente:

- 1 Parte anteriore:
 - Nessun ostacolo e spazio libero.
- 2 Lati/Parte superiore/Retro:
 - Lasciare libere le zone indicate dalle dimensioni di seguito.
- 3 Base:
 - Collocare su una superficie piana. Consentire un'adeguata ventilazione dell'impianto appoggiandolo su un tavolino alto almeno 10 cm.

Front view
Vorderansicht
Face
Vooraanzicht
Vista frontal
Vista frontale

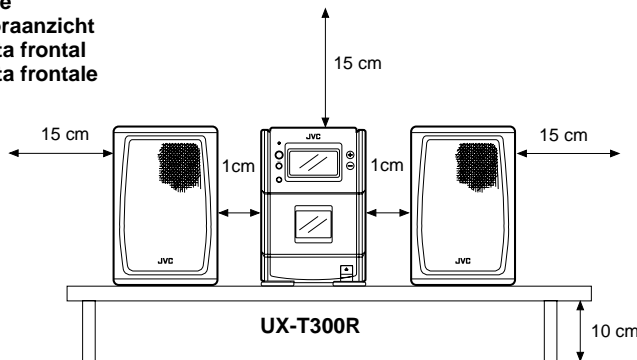

Side view
Seitenansicht
Côté
Zijaanzicht
Vista lateral
Vista laterale

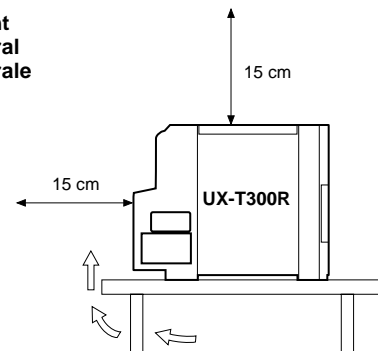

IMPORTANT FOR LASER PRODUCTS/ WICHTIGER HINWEIS FÜR LASER-PRODUKTE / IMPORTANT POUR LES PRODUITS LASER / BELANGRIJKE INFORMATIE VOOR LASERPRODUKTEN / IMPORTANTE PARA LOS PRODUCTOS LÁSER / IMPORTANTE PER I PRODOTTI LASER

REPRODUCTION OF LABELS/ANBRINGUNGSORTE FÜR LASER-PRODUKTE/REPRODUCTION DES ETIQUETTES/VERKLARING VAN DE LABELS/REPRODUCCIÓN DE ETIQUETAS/RIPRODUZIONE DELLE ETICHETTE

- | | |
|--|---|
| 1 CLASSIFICATION LABEL, PLACED ON EXTERIOR SURFACE | 2 WARNING LABEL, PLACED INSIDE THE UNIT |
| 1 KLASSIFIZIERUNGSHINWEIS BEFINDET SICH AUF DER AUSSENSIETE | 2 WARNETIKETTE IM GERÄTEINNEREN |
| 1 ÉTIQUETTE DE CLASSIFICATION, PLACÉE SUR LA SURFACE EXTÉRIEURE | 2 ETIQUETTE D'AVERTISSEMENT PLACÉE À L'INTERIEUR DE L'APPAREIL |
| 1 CLASSIFICATIE-ETIKET AAN DE BUITENKANT VAN HET APPARAAT | 2 WAARSCHUWINGSLABEL, IN HET APPARAAT |
| 1 ETIQUETA DE CLASIFICACION, PROVISTA SOBRE LA SUPERFICIE EXTERIOR | 2 ETIQUETA DE ADVERTENCIA, PEGADA EN EL INTERIOR DE LA UNIDAD |
| 1 ETICHETTA DI CLASSIFICAZIONE POSTA ALL'ESTERNO | 2 ETICHETTA DI AVVERTENZA, SITUATA ALL'INTERNO DELL'APPARECCHIO |

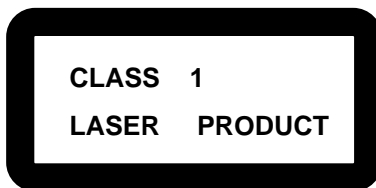

DANGER: Invisible laser radiation when open and interlock failed or defeated. AVOID DIRECT EXPOSURE TO BEAM. (e)	WARNING: Osynlig laserstrålning när denna del är öppnad och spårren är urkopplad. Betrakta ej strålen. (s)	ADVARSEL: Usynlig laserstrålning ved åbning, når sikkerhedsafbrydere er ude af funktion. Undgå udsættelse for stråling (d)	VARO: Avattaessa ja suojalukitus ohitettaessa olet alttiina näkymättömälle lasersäteilylle. Älä katso säteeseen. (f)
---	---	---	---

- | | |
|---|---|
| <ol style="list-style-type: none"> 1. CLASS 1 LASER PRODUCT 2. DANGER: Invisible laser radiation when open and interlock failed or defeated. Avoid direct exposure to beam. 3. CAUTION: Do not open the top cover. There are no user serviceable parts inside the Unit; leave all servicing to qualified service personnel. | <ol style="list-style-type: none"> 1. KLAS 1 LASERPRODUKT 2. GEVAARLIJK: Onzichtbare laserstraling wanneer open en de beveiliging faalt of uitgeschakeld is. Voorkom het direkt blootstaan aan de straal. 3. VOORZICHTIG: De bovenkap niet openen. Binnenin het toestel bevinden zich geen door de gebruiker te repareren onderdelen: laat onderhoud over aan bekwaam vakpersoneel. |
| <ol style="list-style-type: none"> 1. LASER-PRODUKT DER KLASSE 1 2. GEFAHR: Unsichtbare Laserstrahlung bei Öffnung und fehlerhafter oder beschädigter Spre. Direkten Kontakt mit dem Strahl vermeiden! 3. ACHTUNG: Das Gehäuse nicht öffnen. Das Gerät enthält keinerlei Teile, die vom Benutzer gewartet werden können. Überlassen Sie Wartungsarbeiten bitte qualifizierten Kundendienst-Fachleuten. | <ol style="list-style-type: none"> 1. PRODUCTO LASER CLASE 1 2. PELIGRO: En el interior hay radiación láser invisible. Evite el contacto directo con el haz. 3. PRECAUCIÓN: No abra la tapa superior. En el interior de la unidad no existen piezas reparables por el usuario; deje todo servicio técnico en manos de personal calificado. |
| <ol style="list-style-type: none"> 1. PRODUIT LASER CLASSE 1 2. ATTENTION: Radiation laser invisible quand l'appareil est ouvert ou que le verrouillage est en panne ou désactivé. Eviter une exposition directe au rayon. 3. ATTENTION: Ne pas ouvrir le couvercle du dessus. Il n'y a aucune pièce utilisable à l'intérieur. Laisser à un personnel qualifié le soin de réparer votre appareil. | <ol style="list-style-type: none"> 1. PRODOTTO LASER CLASSE 1 2. PERICOLO: Radiazione laser invisibile quando l'apparecchio è aperto ed il dispositivo di sicurezza è guasto o disattivato. Evitare l'esposizione diretta ai raggi. 3. ATTENZIONE: Non aprire il coperchio superiore. Non vi sono parti adoperabili dall'utente all'interno di questo apparecchio; lasciare tutti i controlli a personale qualificato. |

Thank you for purchasing the JVC Micro Component System.
 We hope it will be a valued addition to your home, giving you years of enjoyment.
 Be sure to read this instruction manual carefully before operating your new stereo system.
 In it you will find all the information you need to set up and use the system.
 If you have a query that is not answered by the manual, please contact your dealer.

Features

Here are some of the things that make your System both powerful and simple to use.

- The controls and operations have been redesigned to make them very easy to use, freeing you to just enjoy the music.
 - With JVC's **COMPU PLAY** you can turn on the System and automatically start the Radio, Cassette Deck or CD Player with a single touch.
 - The System incorporates Active Hyper-Bass PRO circuitry to faithfully reproduce low frequency sounds.
 - A 45-station preset capability (30 FM and 15AM (MW/LW)) in addition to auto-seek and manual tuning.
 - Versatile CD options include repeat, random and program play.
 - Auto-reverse tape function.
 - A user-friendly timer lets you record broadcasts while you are out, and wake or fall asleep to music.
 - The System is compatible with RDS (Radio Data System) broadcasting.
 - The EON data enables you to standby for desired information.
 - The PTY Search function searches for programmes in the category you wish.
- In addition, Radio Text can be displayed using data sent by station.



How This Manual Is Organized

- Basic information that is the same for many different functions – e.g. setting the volume – is given in the section 'Common Operations', and not repeated under each function.
- The names of buttons/controls and display messages are written in all capital letters: e.g. TUNER BAND, "NO DISC".
- System functions are written with an initial capital letter only: e.g. Normal Play.

Use the table of contents to look up specific information you require.

We've enjoyed making this manual for you, and hope it serves you in enjoying the many features built into your System.

IMPORTANT CAUTIONS

1. Installation of the Unit
 - Select a place which is level, dry and neither too hot nor too cold. (Between 5°C and 35°C or 41°F and 95°F.)
 - Leave sufficient distance between the Unit and a TV.
 - Do not use the Unit in a place subject to vibrations.
2. Power cord
 - Do not handle the power cord with wet hands!
 - Some power (2.9W) is always consumed as long as the power cord is connected to the wall outlet.
 - When unplugging the Unit from the wall outlet, always pull the plug, not the power cord.
3. Malfunctions, etc.
 - There are no user serviceable parts inside. In case of system failure, unplug the power cord and consult your dealer.
 - Do not insert any metallic object into the Unit.

Table of Contents

Features	1	Using the Cassette Deck (Recording)	14
How This Manual Is Organized	1	Using the Timers	16
IMPORTANT CAUTIONS	1	Care And Maintenance	18
Getting Started	2	Troubleshooting	19
Common Operations	6	Specifications	20
Using the Tuner	7		
Using the CD Player	11		
Using the Cassette Deck (Listening to a Tape) ...	13		

Getting Started

Accessories

Check that you have all of the following items, which are supplied with the System.

- Power Cord (1)
- AM Loop Antenna (1)
- Remote Control (1)
- Batteries (2)
- FM Wire Antenna (1)

If any of these items are missing, contact your dealer immediately.

How To Put Batteries In the Remote Control

Match the polarity (+ and -) on the batteries with the + and - markings in the battery compartment.

R6P(SUM-3)/AA(15F)

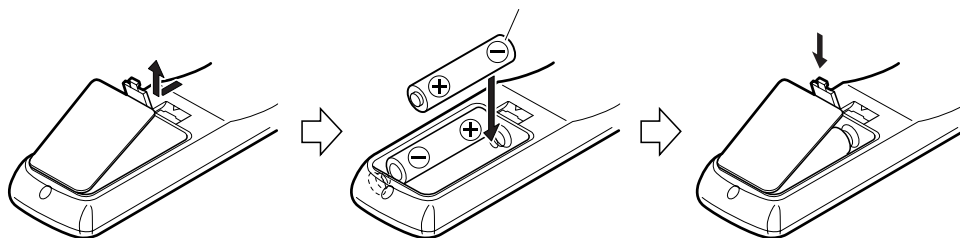

CAUTION: Handle batteries properly.

To avoid battery leakage or explosion:

- Remove batteries when the Remote Control will not be used for a long time.
- When you need to replace the batteries, replace both batteries at the same time with new ones.
- Don't use an old battery with a new one.
- Don't use different types of batteries together.

Using the Remote Control

The Remote Control makes it easy to use many of the functions of the System from a distance of up to 7m (23 feet) away.

You need to point the Remote Control at the remote sensor on the System's front panel.

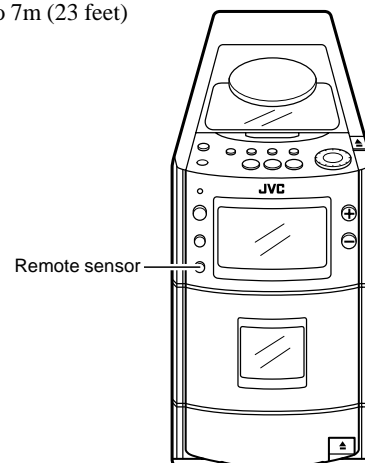

CAUTION: Make all connections before plugging the Unit into an AC power outlet.

Connecting the FM Antenna

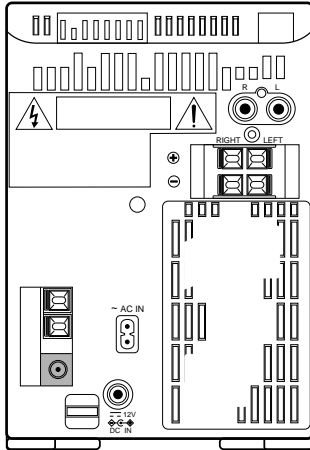

Using the Supplied Wire Antenna

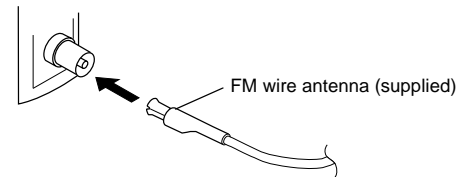

Using an FM 75-Ohm Antenna Wire (Not Supplied)

If reception is poor, connect the outside antenna.

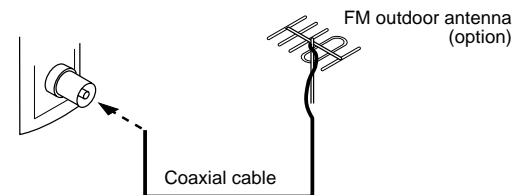

Note: Before attaching a 75 ohm coaxial lead (the kind with a round wire going to an outside antenna), disconnect the supplied FM Wire Antenna.

CAUTION: To avoid noise, keep antennas away from metallic parts of the System, the connecting cord and the AC power cord.

Connecting the AM (MW/LW) Antenna

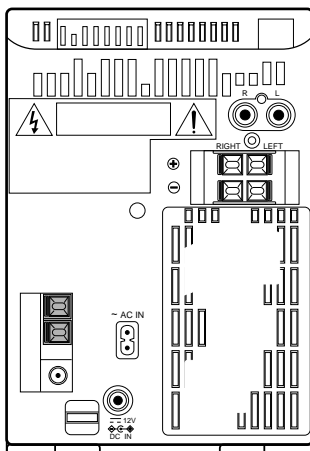

AM loop antenna (Supplied)

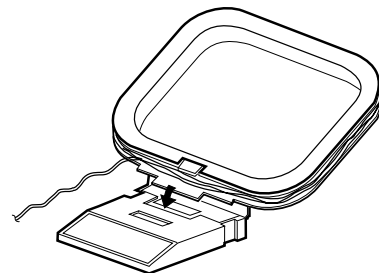

Attach the AM loop to its base by snapping the tabs on the loop into the slot in the base.

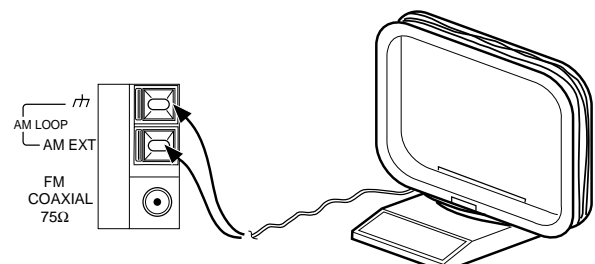

Turn the loop until you have the best reception.

CAUTION: Make all connections before plugging the Unit into an AC power outlet.

Connecting the Speakers

For each speaker, connect one end of the speaker wire to the speaker terminals on the back of the System.

1. Open each of the terminals and insert the speaker wires firmly, then close the terminals.
2. Connect the red (+) and black (-) wires of the right side speaker to the red (+) and black (-) terminals marked RIGHT on the System. Connect the red (+) and black (-) wires of the left side speaker to the red (+) and black (-) terminals marked LEFT on the System.

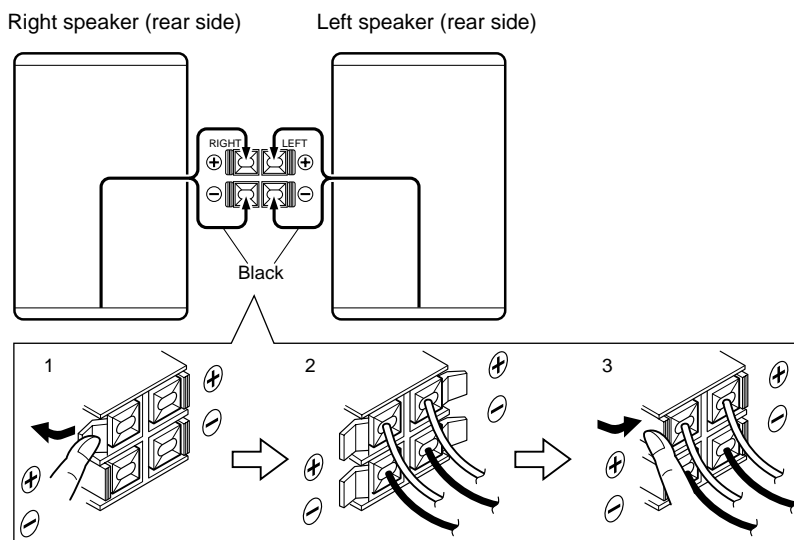

CAUTION: A TV may display irregular colors if located near the speakers. If this happens, set the speakers away from the TV.

Connecting Auxiliary Equipment

Turntable (or MD player)

To listen to this source, press the AUX button.

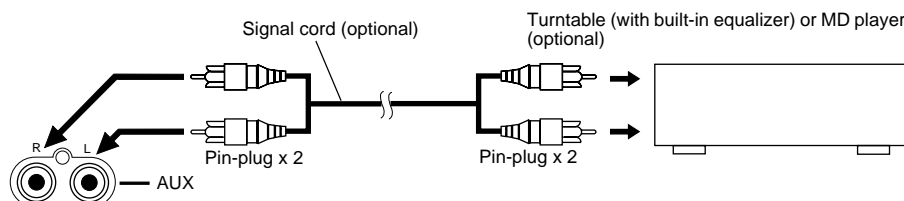

Connecting the AC Power Cord

Firmly insert the supplied AC power cord into the AC inlet on the back of the System.

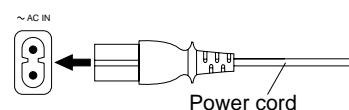

CAUTIONS:

- ONLY USE THE JVC POWER CORD PROVIDED WITH THIS UNIT TO AVOID MALFUNCTION OR DAMAGE TO THE UNIT.
- BE SURE TO UNPLUG THE POWER CORD FROM THE OUTLET WHEN GOING OUT OR WHEN THE UNIT IS NOT IN USE FOR AN EXTENDED PERIOD OF TIME.

Now you can plug the AC power cord into the wall outlet, and your System is at your command!

Operating via your Car Battery (DC12V)

You can operate the System on your car battery via the optional car adaptor (JVC model CA-R120E).

You must connect the adaptor to the System in the following order to avoid accidental short circuit:

1. Be sure that the AC power cord is disconnected.
2. First, connect the car adaptor plug to the DC IN 12V jack on the back of the System.
3. Next, connect the DC inlet of the car adaptor to your car's cigarette lighter socket (DC12V).

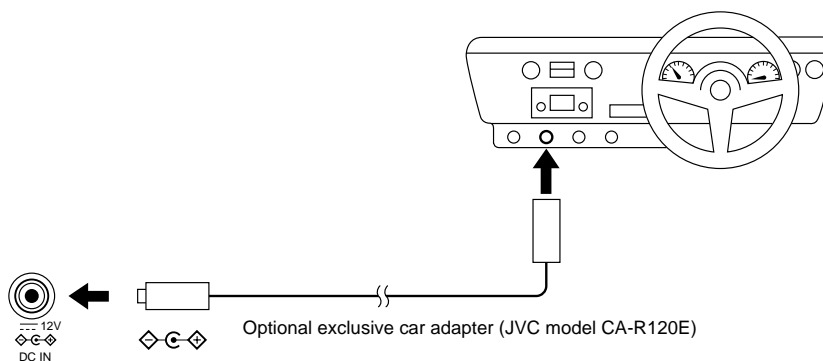

CAUTIONS:

- Use only the specified car adaptor (JVC model CA-R120E) to avoid damage to the System.
- For safety, do not drive your car while listening to the System with headphones.

COMPU PLAY

JVC's COMPU PLAY feature lets you control the most frequently used System functions with a single touch.

With One Touch Operation you can play a CD or tape, turn on the radio etc. with a single press of the play button for that function. One Touch Operation turns the power on for you, then starts the function you have specified. If the Unit is not ready, such as no CD or tape in place, the Unit still powers on so you can insert a CD or tape.

How One Touch Operation works in each case is explained in the section dealing with that function.

The COMPU PLAY buttons are:

On the Unit and on the Remote Control

- CD ▷ button (CD ▶/|| button)
- TUNER/BAND button
- TAPE ◀ button
- AUX button

Removing the speaker grilles

- The speaker grilles can be removed.
- When removing,
 1. Insert your fingers at the top and pull towards you.
 2. Also pull the bottom towards you.

Attaching the speaker grille

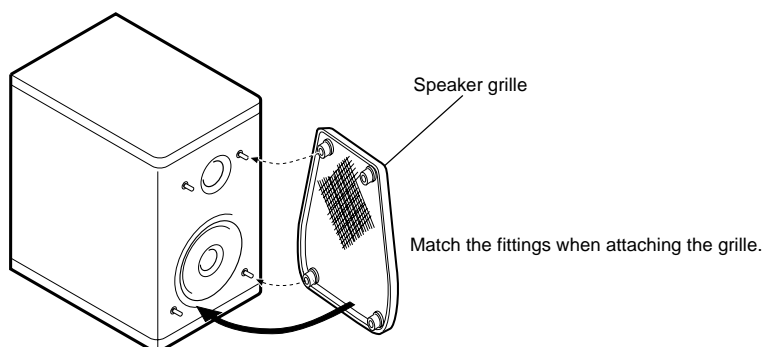

Common Operations

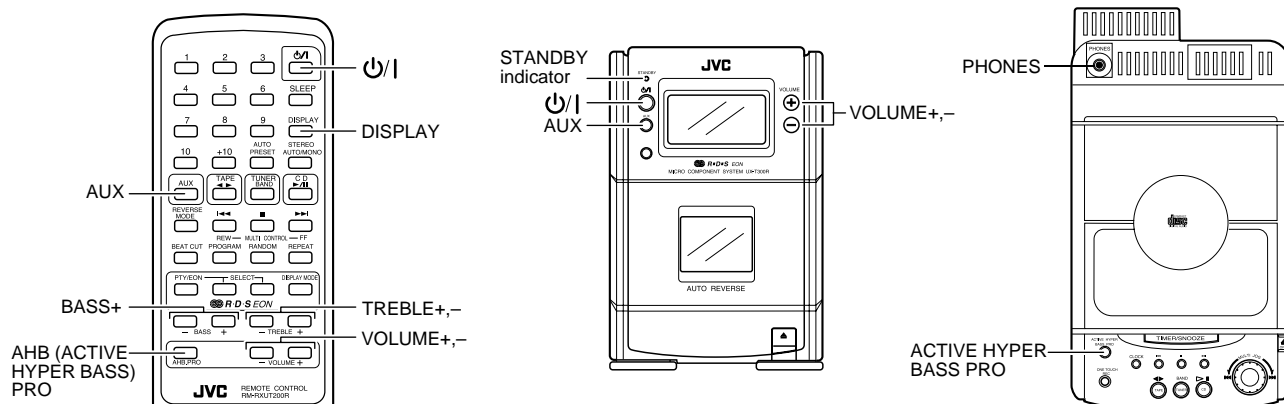

Turning the Power On and Off

Turning the System On

Press the **⏻/⏹** button.

The display comes on and the STANDBY indicator goes out.

The System comes on ready to continue in the mode it was in when the power was last turned off.

- For example, if the last thing you were doing was listening to a tape, you are now ready to listen to a tape again. If you wish, you can change to another source.
- If you were listening to the Tuner last, the Tuner comes on playing the station it was last set to.

Turning the System Off

Press the **⏻/⏹** button again.

The STANDBY indicator lights up and the display is blank, except for the clock display.

- Some power (2.9W) is always consumed even though power is turned off (called Standby Mode).
- To switch off the Unit completely, unplug the AC power cord from the AC outlet (or, if using a car adaptor, unplug that from the unit). When you unplug the AC power cord, the clock will be reset to 0:00 immediately, and preset Tuner stations will be erased after about 24 hours.

Adjusting the Volume

Press the VOLUME + button to increase the volume or press the VOLUME – button to decrease it.

You can adjust the volume level between 0 and 50.

VOLUME 0

CAUTION:

The Volume cannot be adjusted while the Unit is in Standby mode. DO NOT turn on the Unit and/or start playing any source without first setting the VOLUME control to 0, as a sudden blast of sound can damage your hearing, speakers and/or headphones.

For private listening

Connect a pair of headphones to the PHONES jack. No sound comes out of the speakers.

Be sure to turn down the volume before connecting or putting on headphones.

Reinforcing the Bass Sound

You can reinforce the bass sound to maintain rich, full bass at low volume (you can use this effect only for playback):

To get the effect, press the ACTIVE HYPER BASS PRO button. The “BASS” indicator lights up on the display.

To cancel the effect, press the button again. The “BASS” indicator goes out.

Tone Control

You can control the tone by changing the bass and treble.

BASS control

You can adjust the bass level (low frequency range level) between –6 and 6. (0: Flat)

To emphasize the bass level, press the BASS+ button on the Remote Control.

To lower the bass level, press the BASS– button on the Remote Control.

BASS 0

TREBLE Control

You can adjust the treble level (high frequency range level) between -6 and 6. (0: Flat)

To emphasize the treble level, press the TREBLE+ button on the Remote Control.

To lower the treble level, press the TREBLE- button on the Remote Control.

TREBLE 0

Listening to Auxiliary Equipment

You can control the sound from auxiliary equipment played through the System, by applying the sound effects mentioned above.

■ First make sure that the auxiliary equipment is properly connected to the System. (See page 4).

1. Set the VOLUME control to 0.
2. Press the AUX button.

When the System is in Standby mode, the Unit is automatically turned on and "AUX" appears on the display.

AUX

3. Start playing the auxiliary equipment.
4. Adjust the VOLUME control to the desired listening level.
5. Apply sound effects, if you wish.

To cancel Auxiliary mode

You will automatically switch out of auxiliary mode when you start one of the System's built-in sound sources, such as the Tuner or CD Player.

Showing the Time

To show the current time on the display, press the DISPLAY button on the Remote Control.

12:00

Note: You need to set the clock beforehand. (See "Setting the Clock" on page 16)

Using the Tuner

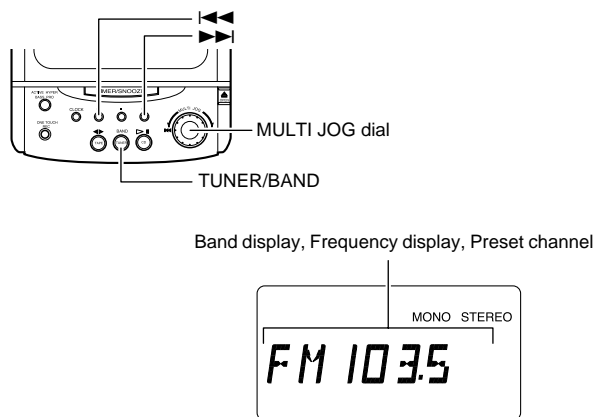
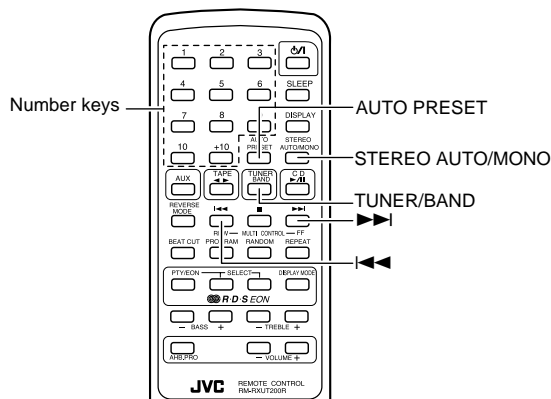

When the System is in use, the display shows other items as well. For simplicity, we show here only the items described in this section.

You can listen to FM and AM(MW/LW) stations. Stations can be tuned in manually, automatically, or from preset memory storage.

■ Before listening to the radio:

- Check that both the FM and AM(MW/LW) antennas are correctly connected. (See page 3).

One Touch Radio

Just press the TUNER/BAND button to turn on the Unit and start playing the station you were last tuned to.

■ You can switch from any other sound source to the radio by pressing the TUNER/BAND button.

Tuning In a Station

Press the TUNER/BAND button to turn on the radio. The Band and Frequency you were last tuned to appear on the display.

Switching Frequency Bands

Press the TUNER/BAND button. Each time you press the button, the band alternates between FM and AM (MW/LW).

Three ways to Select a Station

■ Press the ◀◀ or ▶▶ button repeatedly to move from frequency to frequency until you find the station you want. (Manual Tuning).

OR

■ If you press and hold the ◀◀ or ▶▶ button for one second or more, the frequency changes down, or up, automatically until a station is found. (Auto Tuning).

OR

■ Possible only after presetting stations (Preset Tuning). Turn the MULTI JOG dial to the left or right to go to the next preset station.

You can also use the Remote Control to tune in to preset channels:

Select the station by entering its preset number on the number keys of the Remote Control.

- Example: for channel 5, press 5. For channel 15, press +10 then 5.

P - 15

- After you have selected the preset number, the channel is displayed with its broadcast frequency.

Presetting Stations

You can preset up to 30 FM stations and up to 15 AM (MW/LW) stations using the Remote Control.

Note: Preset numbers may have been set to factory test frequencies prior to shipment. This is not a malfunction. You can preset the stations you want into memory by following one of the presetting methods below.

Manual Presetting

1. Select a band by pressing the TUNER/BAND button.
2. Press the ◀◀ or ▶▶ button to tune in a station.
3. Set the preset number by pressing and holding the number keys on the Remote Control.
 - For preset numbers 1 to 10: Press the number key for the preset number you want to set for more than two seconds.
 - For preset numbers 11 to 15: Press the 1 to 5 buttons for more than two seconds after pressing the +10 button.
 - The preset number appears in the display when you press the number keys. When the key is held down for more than two seconds, the preset number display blinks, indicating it has been set to the new frequency. You can then release the key. This completes the preset setting.

4. Repeat steps 1 - 3 for each station you want to store in memory with a preset number.

Auto Presetting

In each band, you can automatically preset FM-30, AM (MW/LW)-15 stations. Preset numbers will be allocated as stations are found, starting from the lowest frequency and moving up the frequency.

1. Select a band by pressing the TUNER/BAND button.
2. Press the AUTO PRESET button on the Remote Control for more than two seconds.
3. Repeat steps 1-2 for the other band.

CAUTION: If the Unit is unplugged or if a power failure occurs, the preset stations will be erased after about 24 hours. If this happens, you will need to preset the stations again.

To Change the FM Reception Mode

When an FM stereo broadcast is hard to receive or noisy, press the STEREO AUTO/MONO button on the Remote Control so that the "MONO" indicator lights up in the display. Reception improves, but you lose any stereo effect.

To restore the stereo effect, press the STEREO AUTO/MONO button on the Remote Control so that the "MONO" indicator goes off. The "STEREO" indicator lights up and you can hear stereo effects, when a program is broadcast in stereo.

Receiving FM Stations with RDS

(Using the Remote Control)

Using the RDS (Radio Data System) to Receive FM Stations

RDS allows FM stations to send additional signals with their regular programme signals. For example, the stations send their station names, and information about what type of programmes they broadcast, such as sports or music, etc. This unit can receive the following types of RDS signals:

PS (Programme Service):

shows commonly known station names.

PTY (Programme Type):

shows types of broadcast programmes.

RT (Radio Text):

shows text messages the station sends.

TA (Traffic Announcement):

shows traffic announcements being broadcast.

What information can RDS signals provide?

The display shows RDS signal information that the station sends.

To show the RDS signals on the display:

Press the DISPLAY MODE button while listening to an FM station. Each time you press the button, the display changes to show information in the following order:

DISPLAY MODE

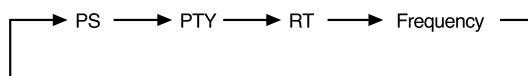

PS (Programme Service):

While searching, "PS" appears, then station name is displayed. "NO PS" appears if no signal is sent.

PTY (Programme Type):

While searching, "PTY" appears, then broadcast programme type is displayed. "NO PTY" appears if no signal is sent.

RT (Radio Text):

While searching, "RT" appears, then a text message sent by the station is displayed. "NO RT" appears if no signal is sent.

Station Frequency:

Station frequency (non-RDS service)

Notes:

- If searching finishes at once, "PS", "PTY" and "RT" will not appear on the display.
- If you press the DISPLAY MODE button while listening to an AM (MW/LW) station, the display only shows station frequency.
- RDS is not available for AM (MW/LW) broadcasts.

On characters displayed

When the display shows PS, PTY or RT signals:

- The display shows upper case letters only.
- The display cannot show accented letters; For example, "A" may represent accented "A's" like "Á, Â, Ã, Ä and Å".

To search for a programme by PTY codes

One of the advantages of the RDS service is that you can locate a particular kind of programme by specifying the PTY codes.

To search for a programme using PTY or TA codes:

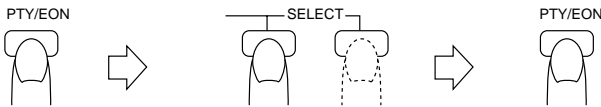

1 **Press the PTY button once while listening to an FM station.**

The display alternates between "PTY" and "SELECT".

2 **Select the PTY code using the SELECT buttons within 10 seconds.**

Each time you press the button, the display shows a category in the following order:

NEWS ↔ AFFAIRS ↔ INFO ↔ SPORT ↔ EDUCATE ↔ DRAMA ↔ CULTURE ↔ SCIENCE ↔ VARIED ↔ POP M ↔ ROCK M ↔ M.O.R.M ↔ LIGHT M ↔ CLASSICS ↔ OTHER M ↔ TRAFFIC ↔ NEWS

3 **Press the PTY button within 10 seconds again.**

While searching, the display alternates between "SEARCH" and the selected PTY code.

The unit searched 30 preset stations and stops when it finds a station of the category you have selected, then tunes into that station.

To continue searching after the first stop,

press the PTY button again while the display indications blink.

If no programme is found, "NOT FOUND" appears on the display.

To stop searching at any time during the process

Using any tuner operating buttons and controls stops search operation.

Descriptions of the PTY Codes

NEWS: News

AFFAIRS: Topical programme expanding on the current news or affairs

INFO: Programmes on medical service, weather forecasts, etc.

SPORT: Sports events

EDUCATE: Educational programmes

DRAMA: Radio plays

CULTURE: Programmes on national or regional culture

SCIENCE: Programmes on natural sciences and technology

VARIED: Other programmes like comedies or ceremonies

POP M: Pop music

ROCK M: Rock music

M.O.R.M: Middle-of-the-road music (usually called "easy listening")

LIGHT M: Light music

CLASSICS: Classical music

OTHER M: Other music

ALARM: Emergency broadcasts

TRAFFIC: Broadcasts which carry traffic announcements

NONE: Undefined (this cannot be searched.)

To temporarily switch to a broadcast programme of your choice

EON (Enhanced Other Networks) is another convenient RDS service that allows this unit to switch temporarily to a broadcast programme of your choice (NEWS, TA or INFO) from the currently selected station, except if you are listening to a non-RDS station (all AM (MW/LW) stations or some FM stations).

- If an FM station does broadcast EON information, EON cannot be activated.

A	A, Á, Â, Ã, Ä, Å, Æ	K	K	L	U, Ú, Û, Ü, Û	0	0	#	*	/	<
B	B	L	L	V	V	1	1	+	+	/	>
C	C, Ç, Ć	M	M	W	W	2	2	-	-	=	=
D	D, Đ	N	N, Ñ	X	X	3	3	'	'	\	\
E	E, É, Ê, Ë, Ë	O	O, Ó, Ô, Õ, Ö, Ø, Ø	Y	Y	4	4	.	.	'	'
F	F	P	P	Z	Z, Ž, Ž	5	5	/	/		
G	G	Q	Q			6	6	---	---		
H	H	R	R, Ř, Ř			7	7	---	---		
I	I, Í, Î, Ï, Ï	S	S, Ś, Ś			8	8	---	---		
J	J	T	T			9	9	!			

To select a programme type

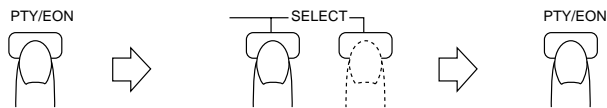

- 1 **Press the EON button twice while listening to an FM station.**

The display alternates between “EON” and “SELECT”.

- 2 **Select the programme type with the SELECT buttons within 10 seconds.**

The display shows a programme type in the following order:



- TA:** Traffic Announcement
- NEWS:** News
- INFO:** Programmes on medical service, weather forecast, etc.
- OFF:** EON off

- 3 **Press the EON button within 10 seconds again to set the selected programme type.**

The selected programme type indicator lights up on the display, and the unit enters EON Standby mode.

- The EON indicator lights up when tuned to a station which provides EON information.

Case 1: If there is no station broadcasting the type of programme you have selected

The broadcast station being currently heard will continue to be heard.



When a station starts broadcasting the programme you have selected, this unit automatically switches to the station. The programme type (TA, NEWS or INFO) indicator starts blinking.



When the programme is over, this unit goes back to the currently selected station, but still remains in EON Standby mode.

Case 2: If there is a station broadcasting the type of programme you have selected

This unit tunes to the station broadcasting the programme. The programme type (TA, NEWS or INFO) indicator starts blinking.



When the programme is over, this unit goes back to the currently selected station, but still remains in EON Standby mode.

Notes:

- If the EON is in standby mode and the function (CD, TAPE, AUX) switch is changed or the power is switched off, then the EON mode will be released. When the band is set to AM (MW/LW), the EON is not activated. When the band is set to FM again, the EON will be set to standby mode.
- When the EON is being operated (i.e. the selected programme type is being received from the broadcast station) and if the DISPLAY MODE, ◀▶ button or MULTI JOG dial is operated, the station will not switch back to the current selected station even after the programme ends. The programme type indicator remains in the display, indicating that the EON is in standby mode.
- When the EON is in standby mode and a radio broadcast is being recorded, be careful because the EON may be activated and a different programme than the intended one may be recorded. When the EON mode is not required, release the EON mode.
- When the alarm signal is detected by EON, the station broadcasting the alarm is received with priority. “ALARM” is not displayed.

Caution:

When the sound alternated intermittently between the station tuned in by the EON function and the current selected station, cancel the EON mode. This does not constitute malfunction of the unit.

Using the CD Player

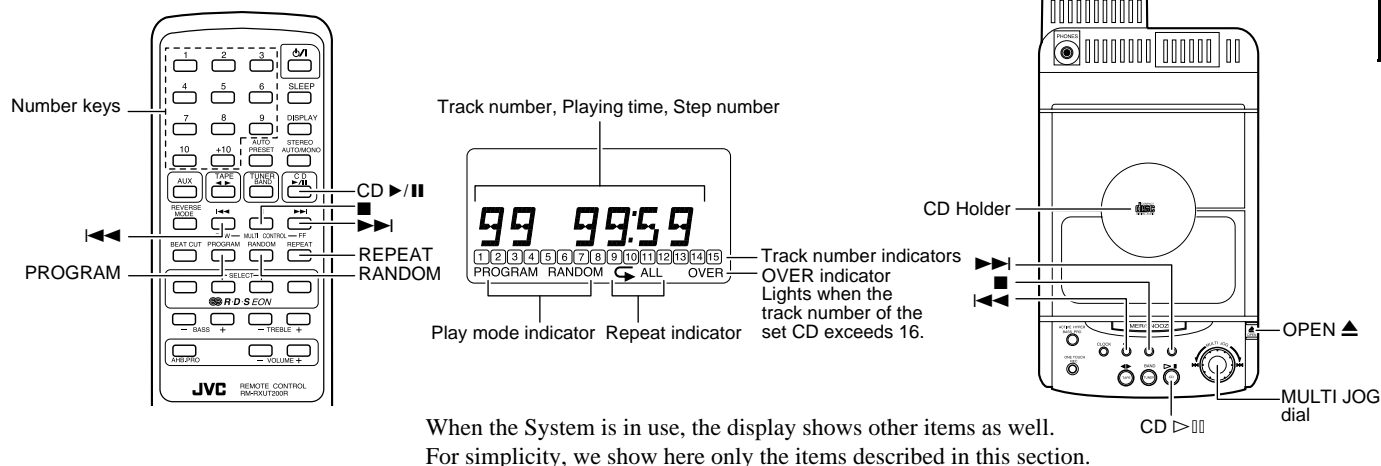

You can use Normal, Random, Program or Repeat Play. Repeat Play can repeat all the tracks or just one of the tracks on the CD.

Here are the basic things you need to know to play a CD and locate the different tracks on it.

The Quickest Way To Start a CD Is With the One Touch Operation

- Press the CD >||| button (or the CD >||| button on the Remote Control).
 - The power is automatically turned on. If a CD is already inserted, it will start playing from the first track.
 - If no CD is inserted, "NO DISC" appears on the display and the CD Player remains in stop mode.

To Insert a CD

1. Press the OPEN ▲ button to open the CD holder.
The CD holder opens.
2. Place a CD, with its label side up as shown below.

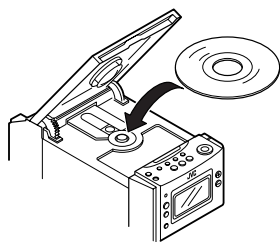

3. Gently close the CD holder by hand.
 - You can place an 8 cm (3") CD without an adaptor.
 - If the CD cannot be read correctly (because it is scratched, for example), "00 0000" appears on the display.

Basics of Using the CD Player — Normal Play

To Play a CD

1. Insert a CD.
2. Press the CD >||| (or the CD >||| button on the Remote Control).
The first track of the CD will begin playing.
The CD Player automatically stops when the last track of the CD has finished playing.

To stop playing the CD, press the e button on the Unit or the Remote Control.

To stop playing and remove the CD, press the OPEN ▲ button to open the CD holder.

To pause, press CD >||| button (or the CD >||| on the Remote Control). The playing time display will blink.

To cancel pause, press the CD >||| button again (or press the CD >||| button on the Remote Control). Play continues from the point where it was paused.

To Select a Track or Passage within a Track

During playback, press the <<< or >>> button on the Unit or the Remote Control to select the track you want.

The selected track starts playing.

Each time you press the <<< or >>> button, the track changes by one.

- Press and release the >>> button to go forward one track at a time.
- Press and release the <<< button to go back one track at a time.

Selecting a Track Using the MULTI JOG dial

Instead of pressing the <<< or >>>, you can select a track by turning the MULTI JOG dial to the left or the right.

Search Play

Holding down the <<< or >>> button on the Unit or the Remote Control, during playback, will fast forward/backwards the CD so you can quickly find a particular passage in the track you are listening to.

Locating a Track with the Remote Control Directly

Using the number keys on the Remote Control allows you to go directly to the beginning of any track.

During playback, enter the number of the track you want to listen to using the number keys.

The selected track starts playing.

- Example: for track 5, press 5. For track 15, press +10 then 5. For track 20, press +10, then 10. For track 32, press +10 three times, then 2.

Programming the Playing Order of the Tracks

You can program the playing order of the tracks using the Remote Control.

- You can program up to 20 tracks in any desired order.
- You can only make a program when the CD Player is stopped.

1. Insert a CD.
2. Press the CD ►/|| button.
3. Press the e button to stop the CD.
4. Press the PROGRAM button.

The Unit enters the programming mode and the "PROGRAM" indicator lights up.



5. Press the number keys (1 to 10 and +10) to select the track to program.
 - Example: for track 2, press 2. For track 15, press +10 then 5. For track 20, press +10 then 10.

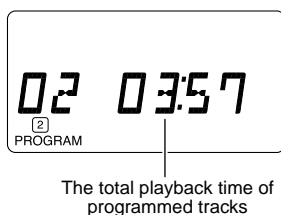

6. Repeat step 5 to select the other tracks for the program.

You can see the total playback time of programmed tracks in the display.
7. Press the CD ►/|| button.

The Unit plays the tracks in the order you have programmed them.

 - You can skip to a particular program track by pressing the ◀◀ or ▶▶ button during program play.

To confirm the programmed tracks, Press the PROGRAM button; the tracks making up the program will be displayed in programmed order.

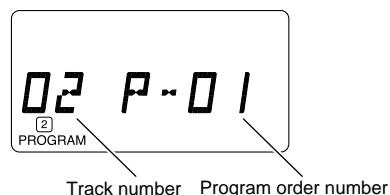

To stop playing, press the e button once.

To delete all the tracks in a program, press the e button on the Unit or the Remote Control while the CD Player is stopped. The "PROGRAM" indicator goes out and the program is deleted. Normal Play is resumed.

The program will also be deleted when you press the OPEN ▲ button to open the CD holder.

Note: If the total playback time of the programmed tracks exceeds 99 minutes 59 seconds, or if more than 21 tracks are programmed, the total playback time will go out on the display.

Random Play

The tracks will play in no special order when you use this mode.

Press the RANDOM button on the Remote Control.

Playback automatically starts and the "RANDOM" indicator lights up on the display.

To skip a track during playback, press the ▶▶ button to jump to the next track in the random sequence. Press the ◀◀ button to jump back to the start of a track being played.

To cancel random play, press the RANDOM button again. The "RANDOM" indicator goes out and Normal Play is resumed.

Repeating Tracks

You can set the program or individual track playing to repeat as many times as you like.

Press the REPEAT button on the Remote Control.

The display changes with each press of the button, as shown below.

→ ◀ → ◀ **ALL** → blank display → (back to the beginning)

- ◀ : Repeats one track.
- ◀ **ALL** : In Normal Play mode, repeats all the tracks. In Program Play mode, repeats all the tracks in the program.

To exit Repeat Mode, press the REPEAT button until the "REPEAT" mode indicator on the display goes out.

Using the Cassette Deck (Listening to a Tape)

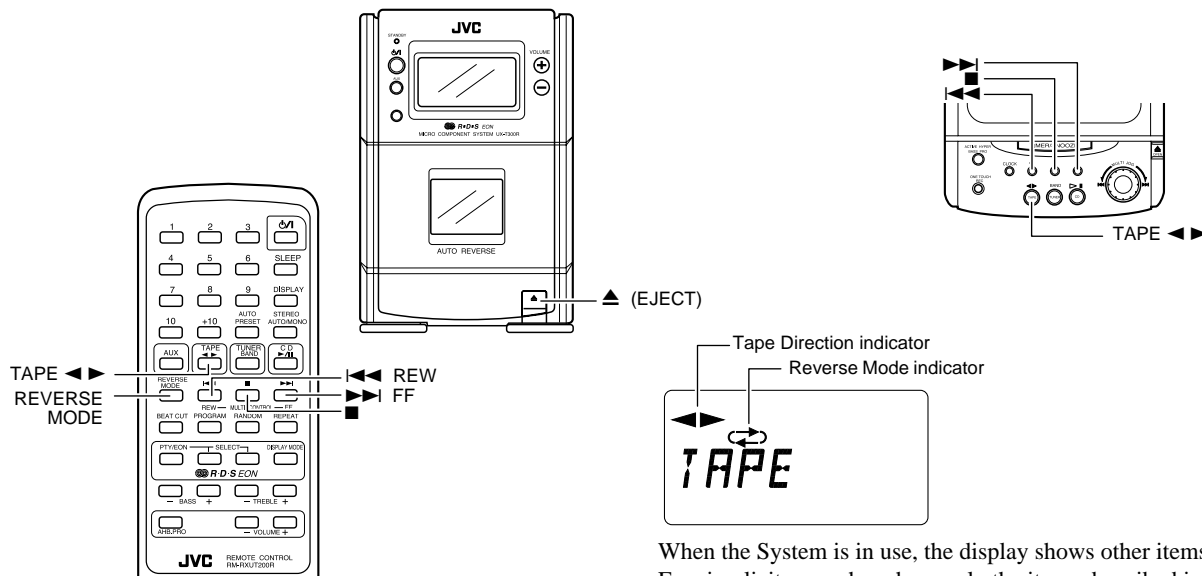

When the System is in use, the display shows other items as well. For simplicity, we show here only the items described in this section.

The Cassette Deck allows you to play and record audio tapes.

- With Automatic Tape Detection, you can listen to type I, II or IV tapes without having to change any settings.

The use of tapes longer than 120 minutes is not recommended, since characteristic deterioration may occur and these tapes easily jam in the pinch-rollers and the capstans.

One Touch Play

By pressing the TAPE button on the Unit or the Remote Control, the Unit will come on, "TAPE" appears in the display, and if a tape is in the deck, it will start to play. If no tape is loaded, the Unit will come on and wait for you to insert a tape, or select another function.

Regular Play

When the power is already on, you can use this basic procedure:

1. Press the ▲ (EJECT) button.
2. When the cassette holder opens, put the cassette in, with the exposed part of the tape down, toward the base of the System.
 - If the cassette holder does not open, turn the Unit off, then back on and press the ▲ (EJECT) button again.

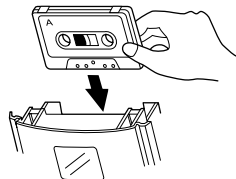

3. Close the holder gently until it clicks.
4. Press the TAPE button.

The tape is played in the direction shown by the Tape Direction indicator.

5. If you need to change the playback direction, press the TAPE button again.

The opposite side Tape Direction indicator lights up and the tape playback direction changes.

To stop playing, press the e button.

To remove the tape, stop the tape, and press the ▲ (EJECT) button.

To Fast-Forward And Rewind A Tape

- Press the ►►► (fast-forward) button on the Unit or the Remote Control to fast-forward the tape.
- Press the ◀◀◀ (rewind) button on the Unit or the Remote Control to rewind the tape.
 - The Cassette Deck automatically stops when the tape reaches its end.

Reverse Mode

You can set a tape to play just one side, both sides in succession, or both sides continuously.

Press the REVERSE MODE button on the Remote Control.

The indicator changes with each press of the button as shown.

→ ⇄ → ⇄ → (back to the beginning)

⇄ : The Cassette Deck automatically stops after playing one side of the tape.

⇄ : The Cassette Deck automatically stops after playing both sides of the tape.

⇄ : The Cassette Deck continues to play both sides of the tape until the e button is pressed.

Using the Cassette Deck (Recording)

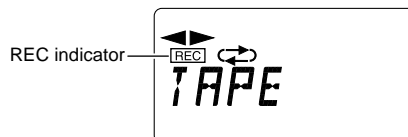
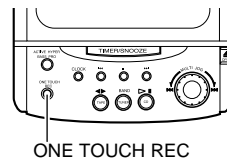
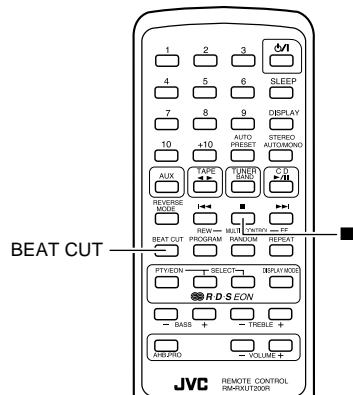

When the System is in use, the display shows other items as well. For simplicity, we show here only the items described in this section.

Recording onto a tape from any of the sound sources is simple. Just place a tape in the Cassette Deck, have the source ready, make one or two settings, and you're ready to record. For each source the procedure is a little bit different so we explain each separately. But first, here are a few things to make your recordings better.

Things To Know Before You Start Recording

- **It may be unlawful to record or play back copyrighted material without the consent of the copyright owner.**
- When you want to record onto both sides of a tape, you can set Reverse mode to do so. Recording automatically stops after recording in the ◀ direction. Therefore, make sure that the tape direction is ▶ when recording with Reverse mode on.
- The recording level, which is the volume at which the new tape is being made, is automatically set correctly, so it is not affected by the VOLUME control on the System. Nor is it affected by adjusting the sound effects. Thus, during recording you can adjust the sound you are actually listening to without affecting the recording level.
- Two small tabs on the back of the cassette tape, one for side A and one for side B, can be removed to prevent accidental erasure or recording.



- To record on a cassette with the tabs removed, you must cover the holes with adhesive tape first. However, when a type II tape is used, only cover part of the hole as shown, since the other part of the hole is used to detect the tape type.
- Type I and Type II tapes can be used for recording.

Note: At the start and end of cassette tapes, there is leader tape which cannot be recorded onto. Thus, when recording CDs or radio broadcasts, wind on the leader tape first to ensure getting the beginning of the recording.

CAUTION: If a recording you make has excessive noise or static, the Unit may have been too close to a TV which was on during the recording. Either turn off the TV or increase the distance between the TV and the System.

Standard Recording

You can record any sound source to tape as follows:

1. Insert a blank or erasable tape into the Cassette Deck and wind past the tape leader.
2. Press the REVERSE MODE button on the Remote Control if you want to record on both sides of the tape.
Press the button until the ⇄ indicator is lit.
 - When using Reverse mode, insert the tape so that it will be recorded in the forwards ▶ direction.
3. Check the recording direction for the tape.
Check that the Tape Direction indicator is the same as that for the tape in the Cassette Deck. If the directions are different, press the TAPE ◀▶ button to correct the tape direction and then press the ⊖ button to stop the tape.

4. Prepare the source, by, for example, tuning in a radio station or turning on connected auxiliary equipment.

Note: For CD recording, refer to “CD Direct Recording” mentioned below.

5. Press the ONE TOUCH REC button on the Unit.

The “REC” indicator lights up and the System begins recording.

Notes for using Reverse mode for recording

When recording in Reverse mode, the System automatically stops when it reaches the end of the reverse ◀ direction. To record on both sides of a tape, make sure that the recording direction for the tape inserted is forwards ▶, and that the Tape Direction indicator is also forwards ▶, before you start recording.

To Stop at Any Time During the Recording Process

Press the e button.

Recording an AM station to tape

When recording an AM broadcast, beats may be produced which are not heard when listening to the broadcast. If this happens, press the BEAT CUT button on the Remote Control to eliminate the beats.

1. Set to AM station and start recording.
2. Press the BEAT CUT button to eliminate the beats. Each time you press the button, the display changes as shown below:
→ CUT-1 → CUT-2 → CUT-3 → CUT-4 → (back to the beginning)

CD Direct Recording

Everything on the CD goes onto the tape in the order it is on the CD, or according to the order you have set in a program.

1. Insert a cassette in the Cassette Deck and wind past the tape leader.
2. Insert a CD.
3. Press the CD ▷ button (or CD ▶ button on the Remote Control).
4. Press the e button.
 - If you want to record specific tracks only, program the tracks beforehand. You can check their total playback time on the display during programming. (See page 12.)
5. If you want to record on both sides of a tape, press the REVERSE MODE button on the Remote Control until the “↔” indicator is lit. Check that the recording direction for the tape and the Tape Direction indicator is correct. (See “Notes for using Reverse mode for recording”.)
6. Choose whether to have pauses between recorded selections.
 - If nothing is done, a non-recorded pause of about four seconds will be automatically left between selections.
 - If you do not want pauses between selections, do the following before proceeding to the next step.

Press the CD ▷ button (or the CD ▶ button on the Remote Control) twice.

The CD player enters Pause mode.

7. Press the ONE TOUCH REC button on the Unit.

The “REC” indicator lights up and the System begins recording.

- If you make a recording with Reverse mode on, the Unit will record the last song at the end of the first side onto the next side from its beginning when the song has been recorded more than 12 seconds on the first side. If the last song has been recorded less than 12 seconds, then the previous song will again be recorded on the next side as it will not be completely recorded on the first side because of leader tape.
- After the CD player has played the entire CD, or all the programmed tracks, the tape automatically stops.

To stop at any time during the recording process, press the e button. The tape stops after four seconds.

Note: When making SLEEP timer settings while doing CD Direct recording, set enough time to allow for the CD to finish playing, otherwise the power will go off before recording is completed.

One Track Recording

1. Insert a cassette into the Cassette Deck and wind past the tape leader.
2. Play the track on the CD you wish to record.
3. Press the ONE TOUCH REC button on the Unit.

The CD player returns to the beginning of that track and the track is recorded on the tape. After recording, the CD player and Cassette Deck automatically stop.

Using the Timers

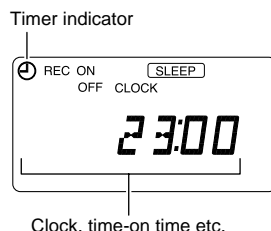
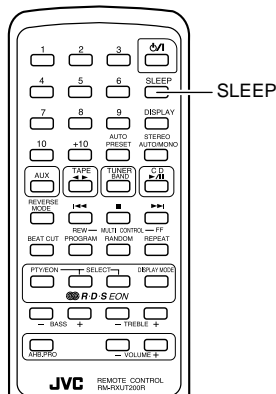
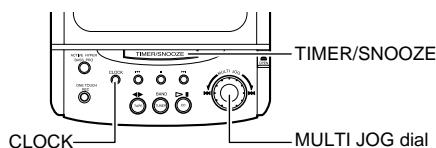

Clock, time-on time etc.

When the System is in use, the display shows other items as well. For simplicity, we show here only the items described in this section.

The timers let you control listening and recording functions automatically.

Setting the Clock

The clock must be correctly set for the timers to work. You can set the clock whether the Unit is on or off.

1. Press the **CLOCK** button on the Unit for more than two seconds.
Set the hour and minute within two minutes respectively. Otherwise, setting is cleared and must be repeated from the beginning.
2. Turn the **MULTI JOG** dial to the right or left to increase or decrease the hour.
The hour changes with every two clicks of the dial.
3. Press the **CLOCK** button.
The minute digits blink on the display.
4. Turn the **MULTI JOG** dial to the right or left to increase or decrease the minute.
The minute changes with every two clicks of the dial.
5. Press the **CLOCK** button.
The selected time is set and the seconds start counting from 0.

CAUTION: If there is a power failure, the clock loses its setting. The display shows "0:00" and the "CLOCK" indicator blinks, and the clock must be reset.

Setting the Timer

You can set the Timer whether the Unit is on or off.

1. Press the **TIMER/SNOOZE** button on the Unit for more than two seconds.
The Timer indicator and "ON" indicator light up and the hour digits blink on the display.
Perform each setting within 30 seconds. Otherwise, setting is cleared and must be repeated from the beginning.

2. Set the time you want the Unit to come on.
(Example: To set the timer to 12:15)

1. Set the hour by turning the **MULTI JOG** dial to the right or left in the same way you set the time for the clock.

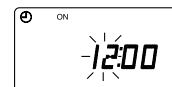

2. Press the **TIMER/SNOOZE** button.
3. Set the minute by turning the **MULTI JOG** dial to the right or left.

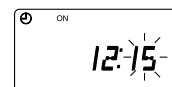

4. Press the **TIMER/SNOOZE** button.
The "ON" indicator goes out and the "OFF" indicator lights up on the display.

3. Set the time you want the Unit to be turned off.

(Example: To set the timer stop time to 13:15)

1. Set the hour by turning the **MULTI JOG** dial.



2. Press the **TIMER/SNOOZE** button.
3. Set the minute by turning the **MULTI JOG** dial.

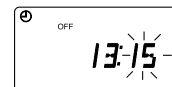

4. Press the **TIMER/SNOOZE** button.
The "TUNER" blinks on the display.



4. Turn the **MULTI JOG** dial to the right or left to select the source.

The display changes as shown.

↔ **TUNER** ↔ **TUNER REC** ↔ **CD** ↔ **TAPE** ↔

- TUNER:** Selects the last station you were listening to.
TUNER REC: Records the last station you were listening to.
CD: Plays the CD.
TAPE: Plays the tape.

5. Press the TIMER/SNOOZE button.

The volume level blinks on the display.



6. Turn the MULTI JOG dial to the right or left to select the volume level (0 to 50).



7. Press the TIMER/SNOOZE button.

The timer setting is completed and the display returns to the display before you set the timer.

8. Before turning off the Unit, prepare the music source selected in step 4.

TUNER: Tune to the desired station.

TUNER REC: Tune to the desired station and insert a cassette tape for recording the station.

CD: Insert a CD.

TAPE: Insert a prerecorded cassette tape.

- In the source “TUNER”, “CD”, or “TAPE”, the timer acts as a Daily timer, and having been set will be activated at the same time every day until the setting is turned off. In the source “TUNER REC”, the timer acts as a Once timer. Having been performed, the details of the setting remain stored but the Timer status is set to off. To re-activate the Once timer, press the TIMER/SNOOZE button for more than two seconds. Press the TIMER/SNOOZE button until the display returns to the original display before setting the time.

9. Press the  button to turn off the Unit.

To cancel the timer, press the TIMER/SNOOZE button for more than two seconds until the Timer indicator goes out on the display.

To re-activate the cancelled timer, press the TIMER/SNOOZE button for more than two seconds until the Timer indicator lights up on the display. Press the TIMER/SNOOZE button until the display returns to the original display before setting the time.

To confirm the timer settings, cancel the timer once and then activate the timer again by pressing the TIMER/SNOOZE button for more than two seconds.

Press the TIMER/SNOOZE button repeatedly, and you can see the current timer settings (ON time, OFF time, source, and volume).

To change the timer setting, repeat the setting procedure from the beginning.

- When the timer turns on, it is possible to fade in the sound from volume level 0 (zero) to the preset volume.
- When the volume setting is set to “VOLUME-” (volume level is not specified), the timer playback volume is set to the level used before setting the timer.

CAUTION: If the Unit is unplugged, or a power failure occurs, the clock and timer setting will be lost after about 24 hours. You will need to reset the clock first, then the timer.

5-Minute Snoozing _____

When the timer turns on the music source you can, if you wish, activate the 5-minute snoozing function to temporarily stop playback:

Press the TIMER/SNOOZE button on the Unit. The power is turned off for five minutes for snoozing.

Setting the SLEEP Timer

Use the Sleep Timer to turn the Unit off after a certain number of minutes when it is playing. By setting this timer, you can fall asleep to music and know that your Unit will turn off by itself rather than play all night.

- You can only set the Sleep Timer when the Unit is on and a source is playing.

To set the SLEEP Timer, follow this procedure:

1. With the System on and a source playing, press the SLEEP button on the Remote Control.
The “SLEEP” indicator lights up.
2. Set the length of time you want the source to play before shutting off.
 - Each time you press the SLEEP button, it changes the number of minutes shown on the display in this sequence:
→ 30 → 60 → 90 → 120 → **Cancelled** → (back to the beginning)

After setting the number of minutes for the Sleep Timer, the display will stop blinking after 5 seconds and return to the display as before setting the Sleep Timer.

The Unit is now set to turn off after the number of minutes you set.

To Confirm the Sleep Time

When the SLEEP button is pressed, the remaining sleep time is displayed. If it is pressed again, a new sleep time can be set.

To Cancel the SLEEP Timer Setting

Press the SLEEP button until the “SLEEP” indicator goes off on the display.

Turning off the Unit also cancels the SLEEP Timer.

Care And Maintenance

Handle your CDs, cassette tapes, and Cassette Deck carefully, and they will last a long time.

Compact Discs

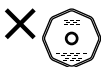

- Only CDs bearing this mark can be used with this unit. However, continued use of irregular shape CDs (heart-shape, octagonal, etc.) can damage the unit.
- Remove the CD from its case by holding it at the edges while pressing the case's center hole lightly.
- Do not touch the shiny surface of the CD, or bend the CD.
- Put the CD back in its case after use to prevent warping.
- Be careful not to scratch the surface of the CD when placing it back in the case.
- Avoid exposure to direct sunlight, temperature extremes, and moisture.
- A dirty CD may not play correctly. If a CD does become dirty, wipe it with a soft cloth in a straight line from center to edge.

CAUTION: Do not use any solvent (for example, conventional record cleaner, spray thinner, benzene, etc.) to clean a CD.

Moisture Condensation



- Moisture may condense on the lens inside the Unit in the following cases:
- After turning on heating in the room.
 - In a damp room.
 - If the Unit is brought directly from a cold to a warm place.

Should this occur, the Unit may malfunction. In this case, leave the Unit turned on for a few hours until the moisture evaporates, unplug the AC power cord, and then plug it in again.

General Notes

In general, you will have the best performance by keeping your tapes, CDs, and the mechanism clean.

- Store tapes and CDs in their cases, and keep them in cabinets or on shelves.
- Keep the Cassette Deck's tape holder and the CD holder closed when not in use.

Cassette Tapes



- If the tape is loose, it may get stretched, cut, or caught in the cassette. Take up the slack by inserting a pencil in one of the reels and rotating.
- Do not touch the tape surface.
- Do not store the tape:
 - In dusty places
 - In direct sunlight or heat
 - In moist areas
 - On a TV or speaker
 - Near a magnet

Cassette Deck

- If the heads, capstans, or pinch-rollers of the Cassette Deck become dirty, the following may occur:
 - Loss of sound quality
 - Discontinuous sound
 - Fading
 - Incomplete erasure
 - Difficulty recording
- Clean the heads, capstans, and pinch-rollers using a cotton swab moistened with alcohol.

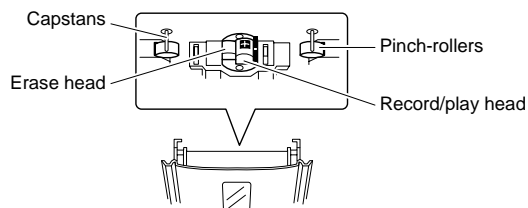

- If the heads become magnetized, the Unit will produce noise or lose high frequency notes.
- To demagnetize the heads, turn off the Unit, and use a head demagnetizer (available at electronics and record shops).

Cleaning the lens

If the lens in the CD pickup is dirty, dropout, etc., could degrade sound.

Open the CD holder and clean the lens as shown.

- Use a blower (available from a camera store) to blow dust off the lens.

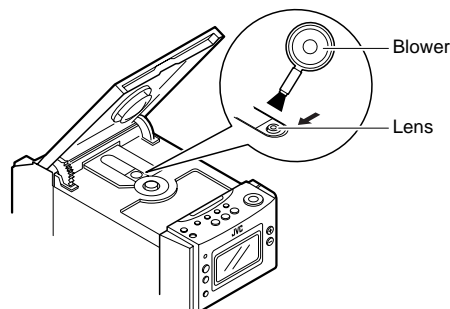



- If there are fingerprints, etc. on the lens, gently wipe clean with a cotton swab.



Troubleshooting

- If you are having a problem with your System, check this list for a possible solution before calling for service.
- If you cannot solve the problem from the hints given here, or the System has been physically damaged, call a qualified person, such as your dealer, for service.

Symptom	Possible Cause	Action
No sound is heard.	<ul style="list-style-type: none"> • Connections are incorrect, or loose. • Headphones are connected. 	<ul style="list-style-type: none"> • Check all connections and make corrections. (See pages 4 - 5.) • Disconnect the headphones.
Unable to record.	Cassette record protect tabs are removed.	Cover the holes on the back edge of the cassette with tape.
Poor radio reception	<ul style="list-style-type: none"> • The antenna is disconnected. • The AM Loop Antenna is too close to the Unit. • The FM Wire Antenna is not properly extended and positioned. 	<ul style="list-style-type: none"> • Reconnect the antenna securely. • Change the position and direction of the AM Loop Antenna. • Extend FM Wire Antenna to the best reception position.
The CD skips.	The CD is dirty or scratched.	Clean or replace the CD.
The CD does not play.	The CD is upside down.	Put the CD in with the label side up.
Unable to operate the Remote Control.	<ul style="list-style-type: none"> • The path between the Remote Control and the sensor on the Unit is blocked. • The batteries have lost their charge. 	<ul style="list-style-type: none"> • Remove the obstruction. • Replace the batteries.
Operations are disabled.	The built-in microprocessor has malfunctioned due to external electrical interference.	Unplug the Unit then plug it back in.
The cassette door cannot be opened.	During tape playing, the power cord was unplugged.	Plug in the power cord, press the  button, and then press the  button.

Specifications

Amplifier

Output Power 32 W (16 W + 16 W) at 4 ohms (Max.)
28 W (14 W + 14 W) at 4 ohms (10% THD)

Input Sensitivity/Impedance (1 kHz)

AUX 300 mV/47 kohms
Speaker terminals 4 - 16 ohms
Phones 16 ohm - 1 kohms
0 - 15 mW/ch output into 32 ohms

Cassette Deck

Frequency Response
Type II (CrO₂) : 60 - 15,000 Hz
Wow And Flutter 0.15% (WRMS)

CD Player

Signal-To-Noise Ratio 90 dB
Wow And Flutter Unmeasurable

Tuner

FM Tuner
Tuning Range 87.5 - 108.0 MHz
AM Tuner
Tuning Range (MW) 522 - 1,629 kHz
(LW) 144 - 288 kHz

Speaker Specifications

(each unit)
Speakers 9 cm cone × 1, 4 cm cone × 1
Impedance 4 ohms
Dimensions 131 × 203 × 202 mm (W/H/D)
Mass Approx. 1.8 kg

General

Dimensions 404 × 209 × 270 mm (W/H/D)
Mass Approx. 6.9 kg

Accessories

Power Cord (1)
AM Loop Antenna (1)
Remote Control (1)
Batteries R6P (SUM-3)/AA (15F) (2)
FM Wire Antenna (1)

Power Specifications

Power Requirements AC 230 V ~ , 50 Hz
DC 12V (via optional CA-R120E car adaptor)
Power Consumption 40 watts (power on mode)
2.9 watts (in Standby mode)

Design and specifications are subject to change without notice.



Free Manuals Download Website

<http://myh66.com>

<http://usermanuals.us>

<http://www.somanuals.com>

<http://www.4manuals.cc>

<http://www.manual-lib.com>

<http://www.404manual.com>

<http://www.luxmanual.com>

<http://aubethermostatmanual.com>

Golf course search by state

<http://golfingnear.com>

Email search by domain

<http://emailbydomain.com>

Auto manuals search

<http://auto.somanuals.com>

TV manuals search

<http://tv.somanuals.com>