

# JVC®

BR-D95U VIDEO CASSETTE RECORDER

### CAUTION

*This section of instruction manual is specially edited for service purpose with modified contents.  
It is not recommended to use, this section for the substitution of the original book in the merchandise.*

## VIDEO CASSETTE RECORDER BR-D95U INSTRUCTIONS

**D-9**  
COMPONENT DIGITAL

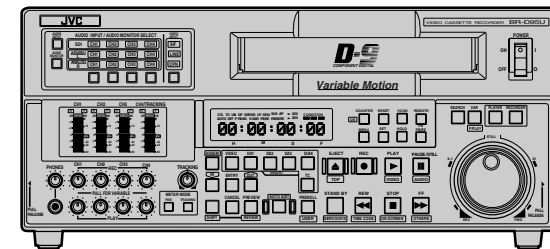

**JVC®**  
VICTOR COMPANY OF JAPAN, LIMITED

JVC® is a registered trademark owned by VICTOR COMPANY OF JAPAN, LTD.  
JVC® is a registered trademark in Japan, the U.S.A., the U.K. and many other countries.  
© 2002 VICTOR COMPANY OF JAPAN, LIMITED

Printed in Japan  
SL96197

#### For Customer Use:

Enter below the Serial No. which is located on the rear of cabinet. Retain this information for future reference.

Model No. **BR-D95U**  
Serial No. \_\_\_\_\_

- This manual provides instructions in English and German.  
English : pp. 2 to 151  
German : pp. 154 to 174
- To maintain picture and sound quality, use the exclusive head cleaning cassette after every 20 hours of operation.  
For details on head cleaning, refer to page 11.

This instruction book is made from 100% recycled paper.

INTRODUCTION

CONTROLS,  
CONNECTORS  
AND DISPLAY

CONNECTIONS

MENU SWITCH  
SETTING

MENU SWITCH  
SETTING  
DETAILS

PREPARATION

RECORDING

PLAYBACK

OTHER  
FUNCTIONS

HOW TO USE  
TIME CODE

EDITING

EDITING SYSTEM  
PHASE  
ADJUSTMENT

RS-232C  
PROTOCOL

TROUBLE-  
SHOOTING

APPENDIX

SPECIFICA-  
TIONS

SL96197

## IMPORTANT SAFEGUARDS

1. Read all of these instructions.
2. Save these instructions for later use.
3. All warnings on the product and in the operating instructions should be adhered to.
4. Unplug this appliance system from the wall outlet before cleaning. Do not use liquid cleaners or aerosol cleaners. Use a damp cloth for cleaning.
5. Do not use attachments not recommended by the appliance manufacturer as they may cause hazards.
6. Do not use this appliance near water – for example, near a bathtub, washbowl, kitchen sink, or laundry tub, in a wet basement, or near a swimming pool, etc.
7. Do not place this appliance on an unstable cart, stand, or table. The appliance may fall, causing serious injury to a child or adult, and serious damage to the appliance. Use only with a cart or stand recommended by the manufacturer, or sold with the appliance. Wall or shelf mounting should follow the manufacturer's instructions, and should use a mounting kit approved by the manufacturer. An appliance and cart combination should be moved with care. Quick stops, excessive force, and uneven surfaces may cause the appliance and cart combination to overturn.
8. Slots and openings in the cabinet and the back or bottom are provided for ventilation, and to insure reliable operation of the appliance and to protect it from overheating, these openings must not be blocked or covered. The openings should never be blocked by placing the appliance on a bed, sofa, rug, or other similar surface. This appliance should never be placed near or over a radiator or heat register. This appliance should not be placed in a built-in installation such as a bookcase unless proper ventilation is provided.
9. This appliance should be operated only from the type of power source indicated on the marking label. If you are not sure of the type of power supplied to your home, consult your dealer or local power company. For appliance designed to operate from battery power, refer to the operating instructions.
10. This appliance system is equipped with a 3-wire grounding type plug (a plug having a third (grounding) pin). This plug will only fit into a grounding-type power outlet. This is a safety feature. If you are unable to insert the plug into the outlet, contact your electrician to replace your obsolete outlet. Do not defeat the safety purpose of the grounding plug.
11. For added protection for this product during a lightning storm, or when it is left unattended and unused for long periods of time, unplug it from the wall outlet and disconnect the antenna or cable system. This will prevent damage to the product due to lightning and power-line surges.
12. Do not allow anything to rest on the power cord. Do not locate this appliance where the cord will be abused by persons walking on it.
13. Follow all warnings and instructions marked on the appliance.
14. Do not overload wall outlets and extension cords as this can result in fire or electric shock.
15. Never push objects of any kind into this appliance through cabinet slots as they may touch dangerous voltage points or short out parts that could result in a fire or electric shock. Never spill liquid of any kind on the appliance.
16. Do not attempt to service this appliance yourself as opening or removing covers may expose you to dangerous voltage or other hazards. Refer all servicing to qualified service personnel.
17. Unplug this appliance from the wall outlet and refer servicing to qualified service personnel under the following conditions:
  - a. When the power cord or plug is damaged or frayed.
  - b. If liquid has been spilled into the appliance.
  - c. If the appliance has been exposed to rain or water.
  - d. If the appliance does not operate normally by following the operating instructions. Adjust only those controls that are covered by the operating instructions as improper adjustment of other controls may result in damage and will often require extensive work by a qualified technician to restore the appliance to normal operation.
  - e. If the appliance has been dropped or the cabinet has been damaged.
  - f. When the appliance exhibits a distinct change in performance – this indicates a need for service.
18. When replacement parts are required, be sure the service technician has used replacement parts specified by the manufacturer that have the same characteristics as the original part. Unauthorized substitutions may result in fire, electric shock, or other hazards.
19. Upon completion of any service or repairs to this appliance, ask the service technician to perform routine safety checks to determine that the appliance is in safe operating condition.

PORTABLE CART WARNING  
(symbol provided by RETAC)



## SAFETY PRECAUTIONS ( FOR USA AND CANADA )



**CAUTION**  
RISK OF ELECTRIC SHOCK  
DO NOT OPEN

CAUTION: TO REDUCE THE RISK OF ELECTRIC SHOCK,  
DO NOT REMOVE COVER (OR BACK).  
NO USER-SERVICEABLE PARTS INSIDE.  
REFER SERVICING TO QUALIFIED SERVICE PERSONNEL



The lightning flash with arrowhead symbol, within an equilateral triangle, is intended to alert the user to the presence of uninsulated "dangerous voltage" within the product's enclosure that may be of sufficient magnitude to constitute a risk of electric shock to persons.



The exclamation point within an equilateral triangle is intended to alert the user to the presence of important operating and maintenance (servicing) instructions in the literature accompanying the appliance.

**WARNING:**  
TO REDUCE THE RISK OF FIRE OR ELECTRIC SHOCK, DO NOT EXPOSE THIS APPLIANCE TO RAIN OR MOISTURE.

This unit should be used with 120 V AC only.

**CAUTION:**  
To prevent electric shocks and fire hazards, do NOT use any other power source.

### NOTE:

The rating plate (serial number plate) is on the rear of the unit.

### INFORMATION

This equipment has been tested and found to comply with the limits for a Class A digital device, pursuant to Part 15 of the FCC Rules. These limits are designed to provide reasonable protection against harmful interference when the equipment is operated in a commercial environment. This equipment generates, uses, and can radiate radio frequency energy and, if not installed and used in accordance with the instruction manual, may cause harmful interference to radio communications.

Operation of this equipment in a residential area is likely to cause harmful interference in which case the user will be required to correct the interference at his own expense.

### CAUTION

CHANGES OR MODIFICATIONS NOT APPROVED BY JVC COULD VOID USER'S AUTHORITY TO OPERATE THE EQUIPMENT.

This Class A digital apparatus meets all requirements of the Canadian Interference-Causing Equipment Regulations.



**ATTENTION**  
RISQUE D'ELECTROCUTION  
NE PAS OUVRIR

ATTENTION: POUR EVITER TOUT RISQUE D'ELECTROCUTION  
NE PAS OUVRIR LE BOITIER.  
AUCUNE PIECE INTERIEURE NEST  
A REGLER PAR L'UTILISATEUR.  
SE REFERER A UN AGENT QUALIFIE EN CAS DE PROBLEME.



Le symbole de l'éclair à l'intérieur d'un triangle équilatéral est destiné à alerter l'utilisateur sur la présence d'une "tension dangereuse" non isolée dans le boîtier du produit. Cette tension est suffisante pour provoquer l'électrocution de personnes.



Le point d'exclamation à l'intérieur d'un triangle équilatéral est destiné à alerter l'utilisateur sur la présence d'opérations d'entretien importantes au sujet desquelles des renseignements se trouvent dans le manuel d'instructions.

\*Ces symboles ne sont utilisés qu'aux Etats-Unis.

**AVERTISSEMENT:**  
POUR EVITER LES RISQUES D'INCENDIE OU D'ELECTROCUTION, NE PAS EXPOSER L'APPAREIL A L'HUMIDITE OU A LA PLUIE.

Ce magnétoscope ne doit être utilisé que sur du courant alternatif en 120 V.

**ATTENTION:**  
Afin d'éviter tout risque d'incendie ou d'électrocution, ne pas utiliser d'autres sources d'alimentation électrique.

### REMARQUE:

La plaque d'identification (numéro de série) se trouve sur le panneau arrière de l'appareil.

Cet appareil numérique de la classe A respecte toutes les exigences du Règlement sur le matériel brouilleur du Canada.

# SAFETY PRECAUTIONS ( FOR EUROPE AND AUSTRALIA )

## Warning Notice

### FOR YOUR SAFETY (Australia)

1. Insert this plug only into effectively earthed three-pin power outlet.
2. If any doubt exists regarding the earthing, consult a qualified electrician.
3. Extension cord, if used, must be three-core correctly wired.

## IMPORTANT (In the United Kingdom)

### Mains Supply (AC 230 V ~)

#### WARNING – THIS APPARATUS MUST BE EARTHED

The wires in this mains lead are coloured in accordance with the following code;

GREEN-and-YELLOW: EARTH  
 BLUE : NEUTRAL  
 BROWN : LIVE

As the colours of the wires in the mains lead of this apparatus may not correspond with the coloured markings identifying the terminals in your plug, proceed as follows.

The wire which is coloured GREEN-AND-YELLOW must be connected to the terminal in the plug which is marked with the letter E or by the safety earth symbol  $\perp$  or coloured GREEN or GREEN-AND-YELLOW. The wire which is coloured BLUE must be connected to the terminal which is marked with the letter N or which is coloured BLACK. The wire which is coloured BROWN must be connected to the terminal which is marked with the letter L or coloured RED.

This apparatus is designed in compliance with ISO 7779/1999 (Acoustics -- Measurement of airborne noise emitted by information technology telecommunications equipment), whose acoustic noise is less than 70 dB.

## POWER SYSTEM

### Connection to the mains supply

This unit operates on voltage of 110 V to 240 V AC, 50 Hz/60 Hz.

## WARNING:

**TO REDUCE THE RISK OF FIRE OR ELECTRIC SHOCK, DO NOT EXPOSE THIS APPLIANCE TO RAIN OR MOISTURE.**

## CAUTION

To prevent electric shock, do not open the cabinet. No user serviceable parts inside. Refer servicing to qualified service personnel.

## WARNING

This is a Class A product. In a domestic environment this product may cause radio interference in which case the user may be required to take adequate measures.

## Note:

The rating plate and the safety caution are on the rear of the unit.

## WARNING

It should be noted that it may be unlawful to re-record pre-recorded tapes, records, or discs without the consent of the owner of copyright in the sound or video recording, broadcast, or cable programme and in any literary, dramatic, musical or artistic work embodied therein.

## CAUTION

RED colour indications on the operation panel are provided but they are not safety related.

RED colour indications:

- (1) For Cassette Recording Button
- (2) For Level Over Audio In/Out Indicator
- (3) For Tape Error Indicator

This equipment is in conformity with the provisions and protection requirements of the corresponding European Directives. This equipment is designed for professional video appliances and can be used in the following environments:

- Controlled EMC environment (for example purpose built broadcasting or recording studio), and the rural outdoors environment (far away from railways, transmitters, overhead power lines, etc.)

In order to keep the best performance and furthermore for electromagnetic compatibility we recommend to use cables not exceeding the following length:

Port	Cable	Length
AC INPUT	Power supply cord	2.5 meters
SERIAL V/A IN	Coaxial cable	10 meters
SERIAL V/A OUT	Coaxial cable	10 meters
AES/EBU IN, OUT	Coaxial cable	10 meters
RS-232C	Shielded cable	3 meters
REMOTE	Exclusive cable	5 meters
VIDEO CONTROL	Exclusive cable	5 meters
COMPOSITE IN, OUT	Coaxial cable	10 meters
REF IN	Coaxial cable	10 meters
Y/R-Y/B-Y IN, OUT	Coaxial cable	10 meters
TIME CODE IN, OUT	Coaxial cable	10 meters
AUDIO IN CH1, CH2	Shielded twist pair cable	10 meters
AUDIO OUT CH1, CH2	Shielded twist pair cable	10 meters
AUDIO MONITOR	Shielded cable	10 meters
PHONES	Cable with headphones	3 meters

The inrush current of this apparatus is 17 amperes.

## Caution

When in case that the strong electromagnetic waves or magnetism is near the audio in ch1, ch2 cable, the sound will contain noise.

In such case, please keep the cable away from the disturbance.

Thank you for purchasing the BR-D95U DIGITAL S Video Cassette Recorder with electronic editing capabilities.

- This unit can be used with either NTSC or PAL signal systems. Before using this unit, first select the signal system. The signal system you select will be indicated on the counter display with "525" for NTSC and "625" for PAL. For instructions on how to select the signal system, refer to "4-2 VIDEO SIGNAL SYSTEM SELECTION" on page 30.
- The optional SA-D95U digital interface board is required for input/output of serial digital signals.

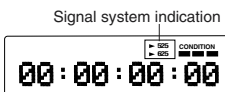

Whenever (NTSC) or (525) is specified in this manual, the accompanying information applies only to the NTSC signal system. Similarly, information that is specified as (PAL) or (625) applies only to the PAL signal system.



This video cassette recorder uses the DIGITAL S format. It can only be used with video tape cassettes bearing the "DIGITAL S" or "D-9" logo.

### CAUTION: 4-channel audio insert editing

**Do not try to perform audio insert editing on tapes with 4 audio channels when using a 2-channel audio DIGITAL S VCR (BR-D85U/E, BR-D80U/E, BR-D750U/E).**  
**If audio insert editing is executed, audio signals recorded on DA3 and DA4 will be erased.**

- Do not record important material in the first two or three minutes of a tape.
- It may be unlawful to use any material recorded from TV broadcast programs or pre-recorded programs without the consent of the owner of copyright, except in cases where this material is recorded exclusively for personal use.
- JVC is not liable for compensation for loss or damage to recordings in the event this unit fails to record or play back properly because the unit malfunctions or a defective video cassette tape is used.
- This unit is designed for professional use.

## MAIN FEATURES

- Superb picture quality achieved by the DIGITAL S format using 4:2:2 component digital processing
- Independently editable 4-channel PCM high-quality sound
- 4-channel PCM high-quality sound with 16-bit 48 kHz sampling. 4-channel audio can be edited independently.
- High-density metal tape based on the W-VHS format
- Built-in time code generator/reader to enable recording and reading of SMPTE/EBU-Standard time code and user bits
- Pre-read function  
This function makes it possible to execute A/B roll editing using only one player (video/audio insert only).
- Swap editing  
The swap control function allows the player VCR to be controlled from the recorder VCR via 9-pin remote cable. This allows automatic editing even when an editing controller is not available.
- Audio split editing  
Audio edit start points can be set separately with the video signal edit start point as a reference.
- Color frame servo function  
This function ensures that continuity of the color subcarrier phase is maintained during editing.
- Audio V fade function  
This function fades the audio level during a transition in V shape to reduce noise.
- Complete analog interface with input/output terminals for composite, color difference component and analog audio signals included as standard
- Internally installable serial digital interface board optionally available for configuration of fully digital systems
- Jog/search dial
- Built-in noiseless slow playback facility for noiseless playback within a speed range of approximately -1 to +1 normal
- Audio monitor facility for search  
The D-9 format provides two linear audio channels, enabling audio monitoring even during video shuttle search.
- Tiltable front panel
- Playback audio output adjustment function
- Recording audio input adjustment function
- Video output adjustment function

## CONTENTS

<b>1 INTRODUCTION</b> .....	<b>8</b>	8-7 Simplified Playback Speed Adjustment Function .....	81
1-1 Outline .....	8	8-8 Shuttle Search/Jog Operation .....	82
1-2 Maintenance .....	9	8-9 Variable Slow Playback .....	83
1-3 Precautions .....	10	8-10 Program Playback .....	85
1-4 Video Cassette .....	11	8-11 FF, REW and Counter Memory Functions .....	86
1-5 Head Cleaning .....	11	8-12 Repeat Playback .....	86
<b>2 CONTROLS, CONNECTORS AND DISPLAYS</b> .....	<b>12</b>	<b>9 OTHER FUNCTIONS</b> .....	<b>87</b>
2-1 Front Panel .....	12	9-1 Extra Line Data Recording/Playback .....	87
2-2 Sub Panel .....	18	9-2 EXTRA LINE, VITC LINE, V. BLANK MASK and PB EXTENSION LINE settings .....	89
2-3 Rear Panel .....	19	9-3 Simultaneous Operation .....	90
2-4 Counter Display .....	21	9-4 Fixed Time Cue Up Function .....	91
2-5 On-screen Display .....	23	9-5 Multi Cue-Up Function .....	92
<b>3 CONNECTIONS</b> .....	<b>25</b>	9-6 Striping Rec Function .....	94
3-1 Input Connections .....	25	<b>10 HOW TO USE TIME CODE</b> .....	<b>96</b>
3-2 Output Connections .....	26	10-1 Time Code Display .....	96
3-3 Control System Connections .....	27	10-2 Time Code Initial Setting (Preset) .....	97
<b>4 MENU SWITCH SETTING</b> .....	<b>28</b>	10-3 Time Code Recording .....	99
4-1 Menu Display Modes .....	28	10-4 Time Code Playback .....	101
4-2 Video Signal System Selection .....	30	10-5 Sub Time Code Recording and Playback .....	102
4-3 Menu Switch Setting .....	31	10-6 Time Code Switch Setting for Editing ...	103
4-4 Saving and Calling Up Menu Switch Settings .....	32	<b>11 EDITING</b> .....	<b>104</b>
4-5 Calling Up Functional Menu Switch (Direct Access Function) .....	33	11-1 Outline .....	104
4-6 User Page Registration/Change/Delete (User Page Function) .....	34	11-2 Color Frame Servo Setting .....	105
4-7 How to Lock the Menu Switch Settings .....	37	11-3 Swap Editing .....	107
4-8 Recording Current Adjustment .....	38	11-4 Audio Split Editing .....	112
4-9 Hour Meter Data Display .....	39	11-5 Other Function .....	113
<b>5 MENU SWITCH SETTING DETAILS</b> .....	<b>40</b>	11-6 Manual Editing .....	114
5-1 Menu Switch List .....	40	11-7 Editing with the Pre-read Function .....	115
5-2 Menu Switch Setting Content .....	43	<b>12 EDITING SYSTEM PHASE ADJUSTMENT</b> .....	<b>117</b>
<b>6 PREPARATION</b> .....	<b>65</b>	12-1 Connection .....	117
6-1 Operation Mode Lock .....	65	12-2 Adjustment .....	118
6-2 Standby ON/OFF .....	66	12-3 Dubbing Loop Function .....	122
6-3 Loading and Unloading the Cassette .....	67	<b>13 RS-232C Protocol</b> .....	<b>123</b>
<b>7 RECORDING</b> .....	<b>68</b>	13-1 Command tables .....	123
7-1 Preparation for Recording .....	68	13-2 RS-232C commands .....	124
7-2 Input Video and Audio Signal Selection .....	69	13-3 Speed/data correspondence table .....	134
7-3 Audio Monitor Output Signal Selection .....	70	13-4 Contents of the sense commands .....	135
7-4 Audio Record level Adjustment .....	71	13-5 Menu switch setting information .....	137
7-5 Basic Recording Operations .....	73	<b>14 TROUBLESHOOTING</b> .....	<b>145</b>
7-6 Digital audio signal input/output .....	74	14-1 Warnings with Indicators .....	145
<b>8 PLAYBACK</b> .....	<b>75</b>	14-2 Troubles not to be Warned by Indicators .....	147
8-1 Preparation for Playback .....	75	<b>15 APPENDIX</b> .....	<b>148</b>
8-2 Basic Playback Operations .....	76	15-1 Operation button combinations .....	148
8-3 Audio Playback Level Adjustment .....	77	15-2 Optional Accessories .....	148
8-4 Manual Tracking Adjustment .....	79	15-3 Index .....	149
8-5 Error Correction .....	80	<b>16 SPECIFICATIONS</b> .....	<b>150</b>
8-6 Audio V.Fade Function .....	80		

# 1 INTRODUCTION

## 1-1 OUTLINE

This manual consists of the following sections.

### Section 1 INTRODUCTION

Read this section carefully as it describes the precautions to be taken when operating this unit and the type of cassette to be used.

### Section 2 CONTROLS, CONNECTORS AND DISPLAYS

If you are already familiar with the operation of professional VCRs, you will probably only need to read this section to get started.

### Section 3 CONNECTIONS

This section describes basic connections between the BR-D95U and other units.

### Section 4 MENU SWITCH SETTING

This unit incorporates a "Menu" function which allows you to set a variety of switches on screen. Setting procedures and setting items are described in this section.

### Section 5 MENU SWITCH SETTING DETAILS

This section describes the menu switch items and setting contents in detail.

### Section 6 PREPARATION

This section describes how to set up the unit prior to operation and notes any precautions that need to be taken.

### Section 7 RECORDING

This section describes recording operations and settings.

### Section 8 PLAYBACK

This section describes playback operations and settings.

### Section 9 OTHER FUNCTIONS

This section describes the following special functions.

- Setting the unit to record or play back information added to a video signal on an extra video line.
- Simultaneous operation of more than one VCR
- Cue-up function

### Section 10 HOW TO USE TIME CODE

This section describes time code presetting, recording, and time code playback operation.

### Section 11 EDITING

This section describes the editing operation and pre-read editing.

### Section 12 EDITING SYSTEM PHASE ADJUSTMENT

This section describes internal TBC phase adjustment and the dubbing loop function.

### Section 13 RS-232C protocol

This section describes the data protocols used to control of this unit with a personal computer or other external RS-232C controller.

### Section 14 TROUBLESHOOTING

This section suggests ways to handle potential difficulties or malfunctions.

### Section 15 APPENDIX

This section includes descriptions of optional units and the index for this manual.

### Section 16 SPECIFICATIONS

# 1 INTRODUCTION

## 1-2 MAINTENANCE

The video cassette recorder/player incorporates precision components. Regular maintenance is necessary to maintain the performance level required for professional use. The information below will help you determine a maintenance schedule that will ensure optimum performance over a long period of time.

### • Maintenance

Just as regular oil changes, brake checks, and tune-ups are essential to keep your car running well over a long period, your VCR must be maintained regularly to ensure optimum long-term performance.

Continued use of the VCR without maintenance may lead to the following malfunctions.

- Recording or playback cannot be executed.
- Picture and sound distortion.
- Repeated warnings (stopping the operation). These malfunctions are mostly due to wear or deterioration of the VCR's internal components. Having these repaired can be expensive. Moreover, a sudden malfunction can not only lead to downtime and lost productivity, but can also damage the video cassette.

### • Keeping track of operation (running) time

The total operation time reached by an ordinary home VCR in five to six years may be reached by a professional VCR in as few as five to six months. Therefore, it is important to closely monitor the total operation time. You can check the running time on the provided hour meter (drum running time). The hour meter is shown on the counter display or on-screen display on the monitor.

#### Hour meter indication

The hour meter can be displayed by selecting "DRUM HOUR" on the menu switch setting screen. For details, refer to "Hour meter indication" on page 39.

### • Maintenance schedule

Depending on the operation time, inspect or replace the following mechanism components. Replace the drum assembly (including the heads) and head cleaner every 750 hours.

☆: Cleaning, check and adjustment

○: Check or replace as required. If replacement is not required, clean it.

●: Replace.

Use time	Every 750H	1500H	3000H	4500H	6000H
Drum assembling (including heads)	●	●	●	●	●
Head cleaner	●	●	●	●	●
Tape guide roller, etc.	○	●	●	●	●
Fixed head	☆	○	●	○	●
Belt pinch roller, etc.	○	●	●	●	●
Driving system parts	○	○	○	○	●

This table should be used as reference only. Actual maintenance requirements will vary according to how the unit is used.

### Maintenance consultation

Consult your local JVC dealer for more information about maintenance scheduling and costs.

# 1 INTRODUCTION

## 1-3 PRECAUTIONS

The BR-D95U incorporates highly sophisticated and complex technology. To ensure proper operation, be sure to take the following precautions.

### Transportation

Always hold this unit by the side panels when carrying or moving it. If you hold it by the front panel, the tilt panel may open and you could drop the unit.

### Installation and storage

- Avoid using the unit in places subject to the following conditions:
  - extreme heat or cold
  - strong magnetic field
  - high humidity
  - dust and soil
  - vibrations
- Handle the unit carefully  
Do not block the ventilation openings, or place anything heavy on the unit. Do not put any foreign materials into the cassette loading slot.
- Use the unit in a horizontal (flat) position only.
- Avoid violent shocks to the recording chassis during transportation. Remove the cassette tape from the unit prior to transportation.
- Avoid leaving tapes in the Still or Record Pause mode for a long time as this may damage the tape.
- When not using the unit, set the [POWER] switch to "OFF" to avoid unnecessary power consumption.
- Do not stand or sit on the unit. This will damage the unit and may cause it to fall, resulting in injury.
- Do not install the BR-D95U in a location where it is exposed to radiation, x-rays or corrosive gases.

### Maintenance and cleaning

- This unit contains precision components to ensure the highest performance. For optimum long-term performance, proper maintenance and care are required. Consult your JVC dealer for replacement of parts, adjustment and servicing.
- Use a soft cloth to clean the cabinet. Do not use benzene or thinner as these may melt or cloud the cabinet surface. To remove excessive dirt, clean the unit with a mild detergent diluted with water, then wipe it with a dry cloth.

### About the provided power cables

Two power cables are provided with the BR-D95U. Use the one that corresponds to your power-supply.

- When usage voltage is 120 V or less; use the A-type (flat-pin type) power cable.
- When usage voltage is 127 V or over; use the C-type (round-pin type) power cable.

### Condensation

- Do not use this unit immediately after moving it from a cold place to a warm place or after switching on a heater in a cold room. This will cause water vapor to condense on the video head drum and tape guides and may damage the tape and the VCR.

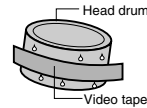

- When condensation occurs, the warning message "02 1" is shown on the tape counter display. The cassette is automatically ejected (see page 145). The head drum then rotates automatically to dry itself. Leave the VCR in this state with the power on. Once the warning message "02 1" has turned off, operation can be resumed.

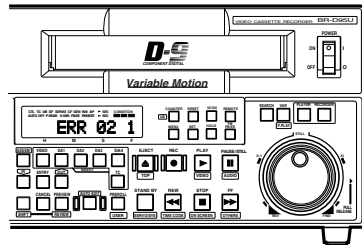

# 1 INTRODUCTION

## 1-4 VIDEO CASSETTE

- Only cassettes bearing the "DIGITAL S" logo can be used with this VCR.
- Cassettes bearing the S-VHS or VHS logo cannot be used with this unit. If an S-VHS or VHS cassette is inserted, it will be automatically ejected.
- Video cassettes cannot be used upside down.
- Leaving the tape in a partially wound condition for a long time may damage the tape. Rewind the tape to the beginning before storage.
- Tape performance cannot be maintained if a cassette is used repeatedly. The more a tape is used, the more dropouts occur. Do not use dirty tapes or tapes which have been damaged as doing so may shorten the service life of the rotary heads.

- Cassettes bearing the "DIGITAL S" logo on the back are provided with a safety slide to prevent accidental erasure.
- Move the slide to OFF to prevent erasure.
- Move the slide to ON to allow recording.

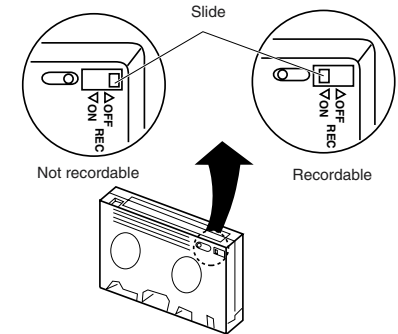

## 1-5 HEAD CLEANING

Repeated recording and playback leads to accumulation of dust and other particles on the video and audio heads. Excessive accumulation will adversely affect the picture or sound quality. If head cleaning is not performed periodically, a type of mosaic noise called block noise may appear in the picture or the sound may be interrupted. **Be sure to clean the tape transport system with a dedicated head cleaning tape (optionally available DCL-5) once every 20 hours.**

Use a dedicated head cleaning tape only. For details on use of the dedicated head cleaning tape, refer to the instructions provided with it.



Block noise

### Head Cleaning mode

This unit is provided with a built-in head cleaner. Use it to remove dust from the heads.

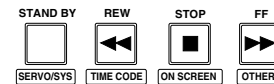

### Cleaning procedure

1. Unload the cassette.
  2. Press the [STANDBY], [REW], [STOP] and [FF] buttons simultaneously.  
The built-in head cleaner in this unit cleans the heads for about 5 seconds.
- If a cassette is inserted during head cleaning, the head cleaning operation stops.

## 2 CONTROLS, CONNECTORS AND DISPLAYS

### 2-1 FRONT PANEL

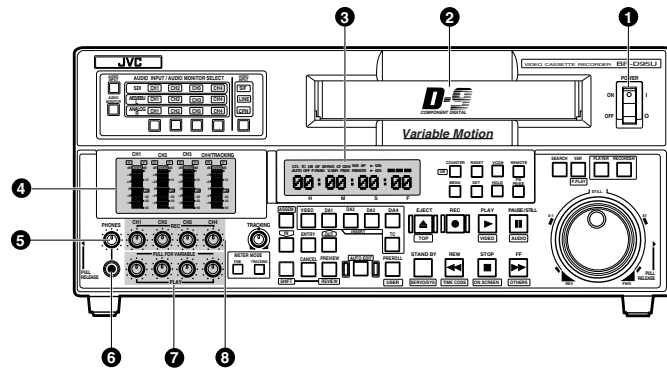

#### 1 [POWER] switch

When power is ON, the counter display is illuminated.

#### 2 Cassette loading slot

S-VHS/VHS tapes cannot be used for either recording or playback.

#### 3 Counter display

Usually displays tape time. With the MENU button pressed, it displays menu switch and hour meter settings. Displays warning codes when an abnormality occurs. For details, refer to page 21.

#### 4 Level meter section

Indicates the audio recording or playback levels.

- The [CH4/TRACKING] meter can be switched between tracking display and CH4 audio level display with the [METER MODE TRACKING] button.
  - Audio Level Display mode can be selected with the [METER MODE FINE] button.
  - When the audio level adjust mode is set to Unity, the [P] or [R] indicator in the upper section of the meter lights. The [P] indicator lights in the Play Volume mode and the [R] indicator lights in the Record Volume mode.
- When the audio level adjust mode is set to Variable, the indicator goes out. You can use the audio level adjust knobs to adjust the levels in this mode.
- The audio reference level can be set with menu switch No. 257 <AUD REF. SIGNAL LEV.> (-20 dB or -18 dB).

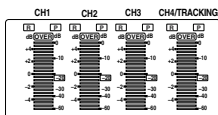

- 5 [PHONES] headphone level adjust control  
Adjusts signal level output from the [PHONES] jack.

#### 6 [PHONES] jack

Connect a set of headphones with a 6 mm-dia. plug to listen to the audio channel selected with the [AUDIO MONITOR] button.

#### 7 [PLAY] audio playback level adjust knobs

Adjust the playback level for each channel (CH1 to CH4). To adjust the audio playback level, pull out the audio level adjust knobs. Turn clockwise to increase the level and counterclockwise to lower it. When audio level adjust knobs are pushed in, the Unity mode is engaged. Turning the knobs in this mode has no effect on the audio level.

There are two ways to adjust playback levels:

One way is to independently adjust playback levels for each channel (CH1 to CH4 channels); the other is to use the CH1 or CH3 adjust knob as a master volume control and the CH2 or CH4 knob as a balance control. You can select the method you prefer with menu switch No. 216 <AUD PB VOLUME MODE1>.

#### 8 [REC] audio recording level adjust knobs

Adjust the recording level for each channel (CH1 to CH4). To adjust the audio recording level, pull out the audio level adjust knobs. Turn clockwise to increase the level and counterclockwise to lower it.

When audio level adjust knobs are pushed in, the Unity mode is engaged. Turning the knobs in this mode has no effect on the audio level.

There are two ways to adjust recording levels:

One way is to independently adjust recording levels for each channel (CH1 to CH4 channels); the other is to use the CH1 or CH3 adjust knob as a master volume control and the CH2 or CH4 knob as a balance control. You can select the method you prefer with menu switch No. 215 <AUD REC VOLUME MODE1>.

## 2 CONTROLS, CONNECTORS AND DISPLAYS

### 2-1 FRONT PANEL

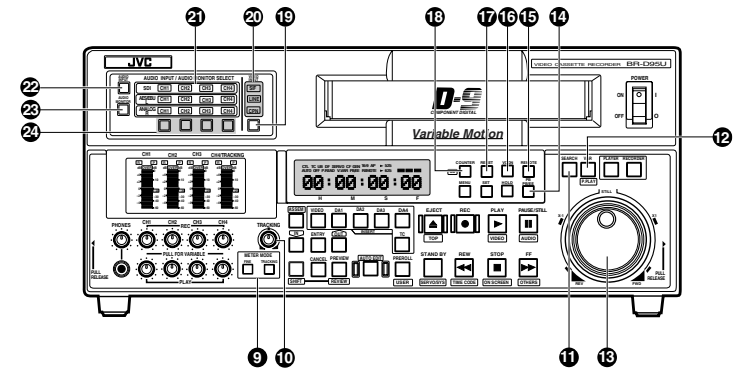

#### 9 [METER MODE] buttons

##### ■ [TRACKING] tracking meter mode button

- Press this button to switch between CH-4 audio level meter and tracking meter.
- This button lights or blinks when the tracking meter is selected. Blinking indicates that auto tracking is OFF. (When setting menu switch No. 005 <AUTO TRACKING> to "OFF")

##### ■ [FINE] fine meter mode button

- Press this button to change the display accuracy of the audio level meter.
- When the [FINE] indicator is illuminated, the meter display is in Fine mode. More precise level adjustment is possible in this mode.

#### 10 [TRACKING] adjust knob

Manually adjusts tracking during playback. After setting the [CH4/TRACKING] meter to Tracking Display mode with the [TRACKING METER MODE] button, adjust this knob until the meter swings to the maximum level.

\* To manually adjust tracking, set menu switch No. 005 <AUTO TRACKING> to "OFF (0)".

#### 11 [SEARCH] button

- Starts search at the search speed set by the search dial.
- In the Menu Switch Setting mode, the menu switch setting can be changed by turning the jog dial while keeping this button pressed.
- During time code presetting, preset data can be changed by turning the jog dial while keeping this button pressed.
- Use this button to change the fixed time cue up data or the video control adjust parameters.

#### 12 [VAR/P.PLAY] button

- To engage the Variable mode, press this button. The button will light when the Variable mode is engaged. In this mode, you can use the 13 search dial to control slow-motion playback speed.

- Press this button while holding the [SHIFT] button down. The button blinks and the Program Play mode is engaged.

\* Before engaging the Program Play mode, engage the Still or Stop mode. For details, refer to "Program Playback" on page 85.

#### 13 Search/jog dials

- Turn for search/jog operation. The outer dial serves as a search control. The inner dial serves as a jog control.
- During playback, turn the jog dial while holding the [PLAY] button down to increase or decrease the playback speed. Playback speed corresponds to the speed with which you turn the dial. Turning the dial clockwise allows you to increase playback speed to up to 2 times normal speed. Turning it counterclockwise allows you to decrease playback speed until tape running stops. If you stop turning the jog dial, normal playback speed is restored.
- In the Variable mode, turn the outer search dial for variable slow playback from -1x to +1x.
- When menu switch No. 301 <DIRECT SEARCH> is set to "OFF", hold the [PLAY] button down and turn the search dial during play to execute variable slow playback.
- In the Program Playback mode, hold the 12 [VAR/P.PLAY] button down and turn the inner jog dial to set the initial speed for program playback or to vary program playback speed.
- The jog dial is also used to select items when setting the menu switches or to set data when presetting the time code.

#### Caution

To use the search dial, first set it to the "STILL" position (with power ON).

## 2 CONTROLS, CONNECTORS AND DISPLAYS

### 2-1 FRONT PANEL

#### ① [PB PB/EE] button

Press to select the playback (PB) exclusive mode or PB/EE auto switching mode. The selected mode is shown by the indicators in the upper section of the counter display. When the PB/EE Auto Switching mode is engaged, set the VCR to the EE mode with menu switch No. 314 <PB/EE MODE>.

#### ② [REMOTE] button

Press to select remote/local operation. When remote operation is selected, "REMOTE" is shown in the upper section of the counter display. In the "REMOTE" mode, the unit can be operated via the remote controller connected to the rear panel's [REMOTE IN (9P)] or [RS-232C] connector. On the VCR itself, only the [STAND BY], [STOP] and [EJECT] buttons will remain operable. To operate the VCR locally, that is with its operation buttons, press the [REMOTE] button so that the "REMOTE" indicator goes out.

#### ③ [VCON] button

Press to adjust the video/audio parameters. Adjustable items are shown on the counter display. Turn the jog dial while pressing the [SEARCH] button to make adjustments. You can adjust the video parameters by connecting an optional video controller to the rear panel's [VIDEO CONTROL] connector. (See page 118.)

#### ④ [RESET] button

Press to reset the CTL counter to "0:00:00:00". The time code and user bits cannot be reset. When the edit points have been set, these settings are canceled. When setting the fixed time cue up, press this button to reset the counter to "00:00:00:00". For details, refer to "Fixed Time Setting" on page 91.

#### ⑤ [COUNTER] button

Press to switch the counter between CTL counter, time code, or user bits display. Press this button while pressing the [SHIFT] button to display user bits. The selected counter display mode is shown by the indicators in the upper section of the counter display.  
CTL: CTL counter display  
TC: Time code display  
UB: User bits display

#### ⑥ Input video signal button

Press to select input video signals. The selected video signal is shown by the ⑩ [VIDEO INPUT] indicators.  
SIF can only be selected when the optional SA-D95U digital interface board is installed. A menu switch is provided to prevent misoperation. Refer to the menu switch setting for No. 371 "INPUT SELECT SAFETY".

#### ⑦ [VIDEO INPUT] indicators

Show the type of video signal selected with the ⑥ input video signal switch.  
SIF: Lights when serial video signal input (via rear panel's [SERIAL V/A IN] connector) is selected.

LINE: Lights when composite video signal input (via rear panel's [COMPOSITE LINE IN] connector) is selected.

CPN: Lights when component video signal input (via rear panel's [COMPONENT IN] connector) is selected.

All lit: All indicators light when the signal from the internal signal generator is selected. The type of signal can be selected with menu switch No. 111 "REC SIGNAL SELECT".

Blinking: The indicator blinks if no signal is input or if the wrong type of signal is input.

#### ⑧ [AUDIO INPUT/AUDIO MONITOR SELECT] indicators

Show whether the input or monitor audio signal is selected. Press the ② [AUDIO INPUT] button or ③ [AUDIO MONITOR] button to switch between the input or monitor indication. The channel indicator blinks if the selected signal does not conform to the standard.

Along with the input indication, the type of signal (SDI, AES/EBU or ANALOG) is shown. With the monitor indication, the audio channel (CH1, CH2, CH3, or CH4) output to the monitor output L or R channel is shown. The channels can be switched with the ④ audio signal select buttons. When these three indicators (SDI, AES/EBU, ANALOG) are lit simultaneously, audio signals (1 kHz sine wave) from the built-in signal generator are selected. The signals from the built-in signal generator can be either 1 kHz audio signals or no sound. This is selectable with menu switches (No. 253 to No. 256). When the input audio signal indication is selected, these indicators blink if no SDI or AES/EBU signal is input. SDI and AES/EBU can only be selected when the optional SA-D95U digital interface board is installed.

#### ⑨ [AUDIO INPUT] button

Press to select the input audio signal for the [AUDIO INPUT/AUDIO MONITOR SELECT] indicators. The button illuminates when selected.

#### ⑩ [AUDIO MONITOR] button

Press to select the monitor audio signal for the [AUDIO INPUT/AUDIO MONITOR SELECT] indicators. The button illuminates when selected.

#### ⑪ Audio signal select buttons

Press to select the input audio signal or monitor audio signal.  
The selected audio signal is shown by the ⑧ [AUDIO INPUT/AUDIO MONITOR SELECT] indicators.

## 2 CONTROLS, CONNECTORS AND DISPLAYS

### 2-1 FRONT PANEL

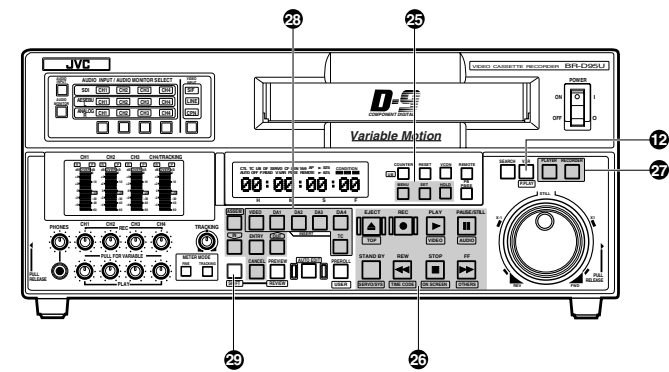

#### ⑫ Setting buttons

##### ■ [MENU] button

Press this button to enter the Menu Switch Setting mode.  
Press this button again to switch back to the Counter Display mode.

##### ■ [SET] button

Press this button to store menu switch setting data in the VCR's memory.  
Press this button to preset data in the time code generator.  
Use this button to end video parameter adjustment or to use the counter memory function.

##### ■ [HOLD] button

Press this button to preset data in the time code generator. To preset time code, the [COUNTER] switch must be set at "TC". To preset user bits, the [COUNTER] switch must be set at "UB".  
\* This button is effective only when the [INT/EXT] switch on the time code setting section is set to "INT" and the [PRESET/REGEN] switch is set to "PRESET".

#### ⑬ Operation buttons

- All buttons are illuminated when pressed.
- The labels printed under the operation buttons indicate the menu items displayed when the button is pressed in the Menu Switch Setting (Direct Access) mode.
- [EJECT] button
  - Press to eject the cassette.
  - TOP menu switch items are displayed when this button is pressed in the Menu Switch Setting mode.
- [REC] button
  - Engages the Record mode when pressed together with the [PLAY] button.
  - To monitor the EE picture during playback, press and hold this button.
  - Press this button in the Stop mode to check preset data in the time code generator.
- [PLAY] button
  - Press to start playback. If pressed together with the [REC] button, recording will start.
  - Video menu switch items are displayed when this button is pressed in the Menu Switch Setting mode.
  - When menu switch No. 301 <DIRECT SEARCH> is set to "OFF", hold this button down and turn the search dial during play to perform variable slow playback.
  - By turning the jog dial while pressing this button in the Play mode, you can vary playback speed between 0 (Still) and +2 (double-speed). Refer to "Simplified playback speed adjustment function" on page 84.
  - In the Program Playback mode, hold the ⑬ [VAR/P.PLAY] button down and press this button to execute program playback.



## 2 CONTROLS, CONNECTORS AND DISPLAYS

### 2-1 FRONT PANEL

#### ■ [PAUSE/STILL]

- Engages the Pause mode when pressed during recording. Press the [PLAY] button to resume recording.
- Engages the Still mode when pressed in the Play, Search or Stop (Standby On/Off) modes. Press the [PLAY] button to resume playback.
- Audio menu switch items are displayed when this button is pressed in the Menu Switch Setting mode.

#### ■ [STANDBY] button

- Switches the Standby mode between ON and OFF in the Stop mode. The button is illuminated in the Standby On mode.
- The head drum continues to rotate when the Standby mode is on. This enables the unit to quickly switch modes when another function is engaged. The head drum does not rotate when the Standby mode is off. This protects the cassette tape and heads from damage.
- Servo and system menu switch items are displayed when this button is pressed in the Menu Switch Setting mode.

#### ■ [REW] button

- Press this button to rewind the tape. The maximum rewind speed during rewind can be selected with menu switch No. 319 <FF/REW MAX SPEED>.
- Output mode during rewinding can be selected with menu switch No. 314 <PB/EE MODE> (with the [PB PB/EE] button set to PB/EE Auto Switching mode).
- Pressing this button together with the [PLAY] button during playback slows playback speed slightly to 0.93 times normal speed.
- Time code menu switch items are displayed when this button is pressed in the Menu Switch Setting mode.

#### ■ [STOP] button

- Press this button to stop any operation. The Output mode in this state can be selected with [PB PB/EE] button.
- On-screen menu switch items are displayed when this button is pressed in the Menu Switch Setting mode.

#### ■ [FF] button

- Press this button to fast-forward the tape. The maximum fast-forward speed can be selected with menu switch No. 319 <FF/REW MAX SPEED>. The Output mode during fast-forward can be selected with menu switch No. 314 <PB/EE MODE> (with the [PB PB/EE] button set to PB/EE Auto Switching mode).

- Pressing this button together with the [PLAY] button during playback increases playback speed slightly to 1.07 times normal speed.
- The drum hour meter is displayed when this button is pressed in the Menu Switch Setting mode.

#### ⑦ [PLAYER/RECORDER] select button

Selects the player or recorder in swap editing. Press the [PLAYER] button to operate the player and the [RECORDER] button to operate the recorder. The button corresponding to the selected unit will be illuminated. (Refer to menu switch No. 372 <P+R AT SWAP MODE> on page 58.)

#### ⑧ [EDITING MODE] select buttons

Use to select assemble editing or insert editing (VIDEO, DA-1 to DA4, TC). Set before preview or actual editing.

**[ASSEM] button:** Press to execute assemble editing. VIDEO, DA1 to DA4 and TC are all recorded.

**[INSERT] buttons:** Press these buttons according to the signal(s) you want to insert.

- A signal corresponding with an illuminated button is "ON". A signal corresponding with a non-illuminated buttons is "OFF".
- You cannot select both assemble and insert editing. Pressing the [ASSEM] button automatically switches OFF the [INSERT] button and vice versa.
- Each of the [INSERT] buttons can be set to ON/OFF during insert editing.
- The [DA1] to [DA4] audio insert buttons blink when the audio edit IN point for the audio split editing has been registered.
- The [ASSEM] button cannot be set to ON/OFF during assemble editing.

#### ⑨ [SHIFT] button

While pressing this button down, press the ⑩ [VAR/P.PLAY] button to start program playback. While pressing this button, press the ⑪ [PREVIEW] button to execute the review operation of editing.

While pressing this button, press the ⑫ [PREROLL] button to execute the fixed time cue up operation. For details, refer to "Fixed Time Cue Up" on page 91. Press the [AUTO EDIT] button while pressing this button to execute a "last edit". For other operation button combinations using the [SHIFT] button, refer to "Operation button combinations" on page 148.

## 2 CONTROLS, CONNECTORS AND DISPLAYS

### 2-1 FRONT PANEL

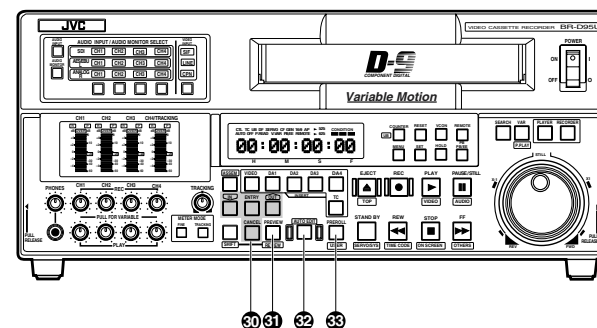

#### ⑩ [EDIT POINT] setting buttons

Use these buttons to register, erase, correct and check edit points.

##### ■ [IN] edit IN button

Use this button to enter the edit IN point and show it on the counter display. Press this button and the [OUT] button simultaneously to display the duration of an edit. When the edit IN point is entered, this button lights. While pressing this button, turn the jog dial clockwise to shift the IN point in the forward direction or turn it counterclockwise to shift the IN point in the reverse direction.

##### ■ [ENTRY] button

Press this button while pressing the [IN] or [OUT] button to enter the edit IN point or OUT point.

##### ■ [OUT] edit OUT button

Use this button to enter the edit OUT point and show it on the counter display. Press this button and the [IN] button simultaneously to display the duration of an edit. When the edit OUT point is entered, this button lights. While pressing this button, turn the jog dial clockwise to shift the OUT point in the forward direction or turn it counterclockwise to shift the OUT point in the reverse direction.

##### ■ [CANCEL] button

Press this button while pressing the [IN] or [OUT] button to cancel the edit IN or OUT point.

#### ⑪ [PREVIEW] button

Press to start editing rehearsal. This button will light. During preview editing, you can press this button again if you want to restart the preview. To review an edit, press this button together with the ⑨ [SHIFT] button.

#### ⑫ [AUTO EDIT] button

Press to start auto editing. This button will light. Press this button while pressing the [SHIFT] button to execute a last edit.

#### ⑬ [PREROLL] button

Press this button when the tape is at the position where you want recording to start after preroll. The tape will be rewound from the point where you press this button for the preroll duration set with the menu switch No.320 "PREROLL TIME". During preroll operation, this button lights and goes out when the preroll operation ends. If an edit IN point has been already entered, preroll is based on the edit IN point. When this button is pressed in the Menu Switch Setting mode, the menu switch items registered for the user menu are shown.

## 2 CONTROLS, CONNECTORS AND DISPLAYS

### 2-2 SUB PANEL

The sub panel can be accessed by opening the operation panel. To open the operation panel, refer to the figure below.

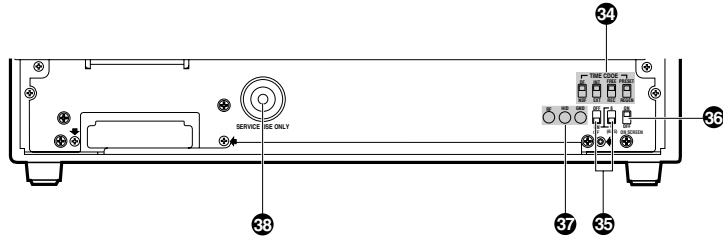

#### 34 [TIME CODE] switches

##### ■ [DF/NDF] drop frame/non-drop frame mode switch (NTSC only)

- To set the time code drop frame/non-drop frame.

\* Effective only when the [INT/EXT] switch is set to "INT" and the [PRESET] switch is set to "PRESET".

DF: To write the time code in the Drop Frame mode. The [DF] indicator lights on the counter display.

NDF: To write the time code in the Non-drop Frame mode.

##### ■ [INT/EXT] time code select switch

- To select internal or external time code generation.

INT: To use the internal time code generator.

EXT: To use an external time code generator.

##### ■ REC/FREE Run mode select switch

- To select one of two Run modes available with the internal time code generator.

\* Effective only when the [PRESET/REGEN] switch is set to "PRESET" and the [INT/EXT] switch to "INT".

REC: Time code runs only during recording.

FREE: Time code runs in real time regardless of the VCR's operating mode. Select this position for editing.

##### ■ PRESET/REGEN select switch

- To select the Internal Time Code Generator mode.

\* Effective only when the [INT/EXT] switch is set to "INT".

PRESET: Select this mode to preset time code data.

REGEN: Select this mode when using the internal time code generator in sync with a playback time code signal.

#### 35 [CF] color frame servo switches

Use to switch the color frame servo ON/OFF.

- For the PAL signal system, select the 4 or 8 field color frame servo with the [4/8] switch on the side.

- For the NTSC signal system, the [4/8] switch is disabled.

\* To set the color frame servo with these switches, set menu switch No. 008 <CAP LOCK> to "SW SEL". (See page 105)

#### 36 [ON SCREEN] select switch

Use to switch the on-screen menu ON/OFF. The on-screen information is output from the [LINE-2 SUPER] connector.

\* If menu switch No. 513 <EDIT ON SCREEN> is set to "ON", you cannot turn the on-screen display off. (See page 24)

#### 37 Service connectors

[RF] ... RF test signal output connector

[HID] ... Trigger signal output connector

[G] ... Ground connector

#### 38 [SERVICE USE ONLY] connector

Used to diagnose malfunctions and for other service procedures.

#### How to open the operation panel

- Lift the bottom edge of the panel to open it. The operation panel can be locked in 6 steps in the range of 0 to 90°.

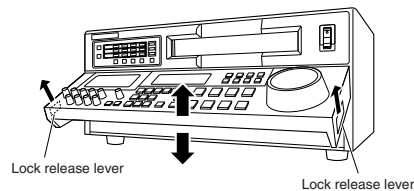

- To return the panel to its original position, pull the lock release levers in the direction shown by the arrows and push down the panel.

## 2 CONTROLS, CONNECTORS AND DISPLAYS

### 2-3 REAR PANEL

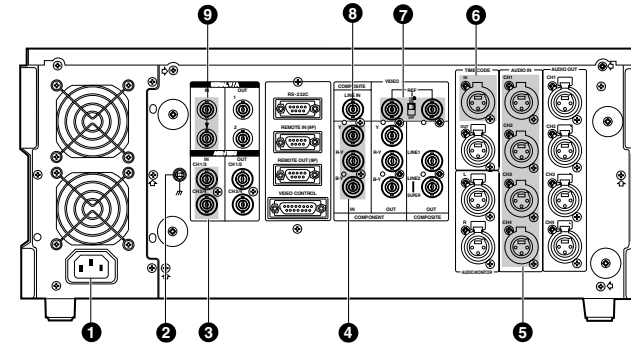

#### 1 [AC IN] socket

Connect to an AC power outlet via the provided power cable.

- When usage voltage is 120 V or less; use the A-type (flat-pin type) power cable.
- When usage voltage is 127 V or over; use the C-type (round-pin type) power cable.

#### 2 [SIGNAL GND] ground terminal

This terminal is a GND for signals among unit.

#### 3 [AES/EBU IN] connector .... BNC x 2

Accepts digital audio interface standard (AES/EBU) digital audio signals.

These signals cannot be input if the optional SA-D95U digital interface board is not installed. Always input external sync signals when inputting digital signals. Both video and audio must be synchronized with the external sync signal.

When the serial digital inputs and outputs of several VCRs are connected in series, do not input the same signal to each VCR as they may not be input correctly. Digital audio signals, in particular, will not be input correctly to the next VCR in the series.

#### 4 [Y-R-Y-B-Y IN] component signal input connector .... BNC x 3

- Accepts component video signals. Set menu switch No. 104 <CPN LEV./SETUP (525)> to select MII (LOW), Bcam (HIGH) and the presence of setup signals (NTSC only). The default setting is Bcam with setup.

#### 5 [AUDIO IN] connector .... XLR x 4

- Accepts analog audio signals.
- Set the input level with menu switches No. 224 to 227 <AUDIO IN LEVEL>. The factory setting is +4 dB.

#### 6 [TIME CODE IN] connector ... XLR

- Accepts external LTC time code signals conforming to the SMPTE/EBU standard. Connect this connector to an external time code generator. A signal containing a large amount of jitter cannot be used for LTC time code. Be sure to use a regenerated signal (stable signal matched with the phase of video signals).

#### 7 [REF IN] external sync signal input connector/ 75 terminating switch (loop-through) .... BNC

- Accepts external reference sync signals. Because of its loop-through design, this connector can distribute signals to other units through the opposite terminal. Set the terminating switch to OFF when distributing signals. If signal distribution is not desired or is terminated at this unit, set the switch to ON.
- Does not accept signals with an input level over 1 V<sub>p-p</sub>.

\* When setting up an editing system, input a black burst or standard color signal to this unit. The [GEN] indicator will light.

#### 8 [COMPOSITE IN] connectors [LINE IN] video line input connector ...BNC

- Accepts composite video signals. Input composite signals passed through the TBC.

#### 9 [SERIAL V/A IN] connectors ... BNC

- Accepts serial video/audio signals. The lower connector is an active loop through connector. If the VCR is not turned on, no signal will be output. Serial signals cannot be input if the optional SA-D95U digital interface board is not installed. Always input external sync signals when inputting digital signals. Both video and audio must be synchronized with the external sync signal.

## 2 CONTROLS, CONNECTORS AND DISPLAYS

### 2-3 REAR PANEL

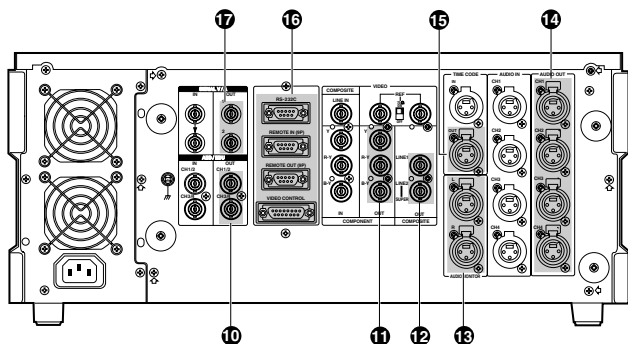

#### 10 [AES/EBU OUT] connector ... BNC x 2

- Outputs digital audio interface standard (AES/EBU) digital audio signals.  
Digital signals cannot be output if the optional SA-D95U digital interface board is not installed.

#### 11 [Y.R-Y.B-Y. OUT] component signal output connector ... BNC x 3

- Outputs the component video signal.  
Set menu switch No. 104 <CPN LEV./SETUP (525)> to select MII (LOW), Bcam (HIGH) and the presence of setup signals (NTSC only).  
The default setting is Bcam with setup.

#### 12 [COMPOSITE OUT] connectors

- [LINE 1] connector  
Outputs composite video signals.
- [LINE 2 - SUPER] connector  
Outputs composite video signals. When the [ON SCREEN] switch on the sub panel is set to "ON", the time counter indication, operating mode, etc. is superimposed on the screen image. The menu switch items are shown in the Menu Switch Setting mode.  
Adjustment parameters and current settings are displayed on screen when the video parameters are being adjusted.

#### 13 [AUDIO MONITOR] connectors

- Outputs the audio signal selected with the front panel's [AUDIO MONITOR] button and 2 audio signal select buttons.
- The output level can be set with menu switches No. 232 to 233 <AUDIO MON LEVEL>. Factory setting is +4 dB.

#### 14 [AUDIO OUT] connectors

- Output analog audio signals.
- The output level can be set with menu switches No. 228 to 231 <AUDIO OUT LEVEL>. Factory setting is +4 dB.

#### 15 [TIME CODE OUT] connector ... XLR

- Outputs a time code signal to the external time code generator. LTC time code conforming to the SMPTE/EBU standard can be output.  
Outputs a time code signal during search if menu switch No. 452 <SEARCH LTC> is set to ON (1).

#### 16 Control connectors

- [RS-232C] connector ... D-Sub 9-pin  
Connect equipment conforming to the RS-232C interface standard such as a personal computer.
- [REMOTE IN (9P)] connector ... D-Sub 9-pin  
Connect an RS-422 serial editing remote control unit.
- [REMOTE OUT (9P)] connector ... D-Sub 9-pin  
Connect a VCR with RS-422 serial interface. Connect to the other VCR's [REMOTE IN] connector to operate it from this VCR.
- [VIDEO CONTROL] connector ... D-Sub 15-pin  
Use to adjust the built-in TBC from an optional video remote controller (Sony's BVR-50).

#### 17 [SERIAL V/A OUT] connector ... BNC x 2

- Outputs serial video/audio signals. When menu switch No. 237 <EMBEDDED AUDIO> is set to "OFF", digital audio signals are not output.  
When connecting to a VCR which is not equipped to handle EMBEDDED AUDIO, set to "OFF".  
No signals are output if the optional SA-D95U digital interface board is not installed.

## 2 CONTROLS, CONNECTORS AND DISPLAYS

### 2-4 COUNTER DISPLAY

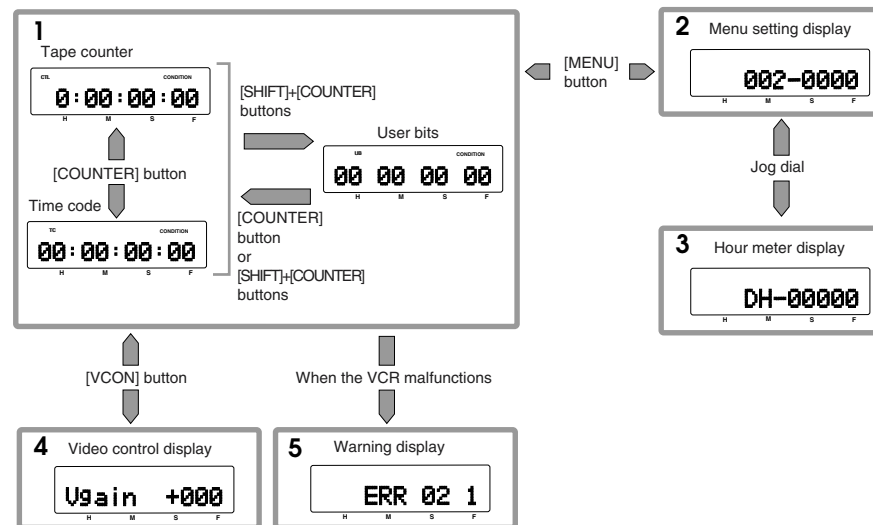

#### 1. Tape counter display

The display usually serves as a tape time counter (hours, minutes, seconds, frames). CTL counter, time code or user bits can be selected with the front panel [COUNTER] switch. "NO TAPE" is displayed if a cassette has not been loaded.

- The Menu Switch Setting mode is entered when the [MENU] button is pressed.

#### How to reset the CTL counter

- Pressing the [RESET] button resets the CTL counter to "0:00:00:00". Time codes and user bits cannot be reset.
- The CTL counter is also reset to "0:00:00:00" when the cassette is ejected.

#### 2. Menu switch setting display

To select menu functions and perform menu switch setting.  
Menu functions and menu switch items can be changed with the jog dial. See page 31 "Menu Switch Setting" for details.

- The counter display shows symbols and numbers.
- Pressing the [MENU] button restores the Tape Counter Display mode.

#### 3. Hour meter data display

Hour meter data (drum operation time) can be displayed in the Menu Switch Setting mode. For details, refer to "Hour meter data display" on page 39.

#### 4. Video/audio control display.

Shows video and audio control adjustment items. Select with the jog dial. Pressing the [VCON] button restores the Tape Counter Display mode.

#### 5. Warning code display

If a malfunction occurs, the corresponding warning code is automatically displayed. For details, refer to "Warnings with Indicators" on page 145.

## 2 CONTROLS, CONNECTORS AND DISPLAYS

### 2-4 COUNTER DISPLAY

#### Indicator section

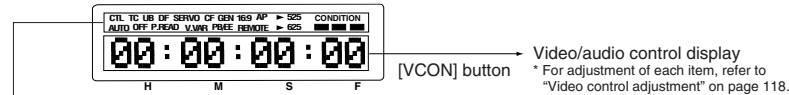

Indication	Meaning when lit
CTL	The CTL counter is shown.
TC	The time code is shown.
UB	The user bits are shown.
DF	The CTL counter or time code is in the drop-frame mode. (525)
SERVO	Servo is stable.
CF	The color frame servo is set. This indication lights during recording. When the [CF] switch is ON and a tape with color frame information is played back, this indication also lights. When the PLAYER is selected during SWAP editing, the [CF] indication does not light.
GEN	Signals are input to the [REF] connector.
(Blinking) GEN	The input digital audio signals cannot be recorded correctly because no external sync signal is input.
16:9	Wide aspect ID signal is being played back.
AP	A non-D-9 tape is played back.
AUTO OFF	A malfunction or abnormality has occurred.
P. READ	The VCR is in the Pre-read mode.
V. VAR	The video parameters can be adjusted.
PB/EE	The PB/EE Auto Switching mode is selected.
PB	The PB mode is selected.
REMOTE	The VCR is in the Remote mode.
CONDITION	
■	Channel condition is normal.
■ ■	Minor errors.
■ ■ ■	Major errors. Normal playback is not possible.
(Blinking) ■ ■ ■ ■	Tracking is not correct.
Video signal system	
▶ 525	The NTSC signal system is set.
▶ 625	The PAL signal system is set.
The video signal system can be set with menu switch No. D95 <525/625> (on the top menu). After selecting the video signal system, turn this unit OFF then ON again to switch to the selected video signal system.	

\* During swap editing, player information is shown only by the indicators in the ■ section when the player is selected. The [AUTO OFF] indicator always shows recorder information.

The following error messages may be displayed during swap editing.

Indication	Meaning
Local	The player's Local/Remote is set to "Local".
No Tape	No cassette is loaded in the VCR.
Bump Error	Bump error occurs.
No Edit Cmd	The edit mode is not selected.
Dur = 0	Duration is set to 0.
Servo Error	Servo error occurs.
Split No A.	The audio insert mode is not selected.
Rec Inh	Recording is not possible on this cassette.
IN/OUT Rev	The IN and OUT points are reversed in terms of the timeline.
Over 300%	Tape speed is more than 3x.
Over -200%	Reverse tape speed is more than -2x.
VTR No Play	The VCR will not function. During editing, the VCR stops.
AuCondition	Editing was interrupted because of audio conditions deteriorated.
NO CTL	Stops the operation when insert editing is executed in a non-recorded section.

- Press the [STOP] button to release error display indications.
- "No Tape" indication goes out when a cassette tape is loaded.

## 2 CONTROLS, CONNECTORS AND DISPLAYS

### 2-5 ON-SCREEN DISPLAY

#### 1. Tape counter display, etc.

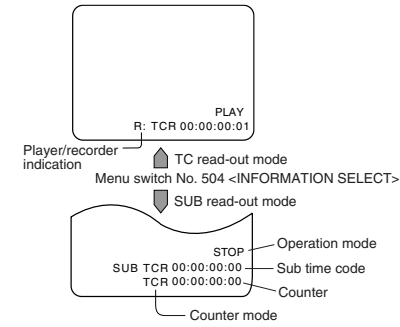

CTL	: CTL data
TCR	: Time code reader data
TC1	: Time code reader data (when the first field is played back)*
TC2	: Time code reader data (when the second field is played back)*
TCR*	: CTL interpolation mode
TCG	: Time code generator data
UBR	: User bits reader data
UBG	: User bits generator data
LTC	: LTC data

\* Shown when the tape speed is less than  $\pm 0.3x$ .

#### Player/recorder indication

When the editing screen display is not shown during swap editing, this indicates which VCR's data is currently displayed on the tape counter.

P: When the player is selected (SUBTC is not shown)

R: When the recorder or both the recorder and player are selected.

#### Drop-frame display (NTSC only)

In recording or playback in the Drop-frame mode, the counter display is as shown below.

TCR 00:00:00:00

Drop frame indication

#### 2. Menu setting display

002:OPERATION LOCK	OFF
003:SYNC SELECT	AUTO
005:AUTO TRACKING	ON
008:CAP LOCK(525)	SW SEL
009:CAP RE-LOCKING DIR.	ACCELERATION

#### 3. Hour meter data display

DH:DRUM HOUR METER	0002
--------------------	------

#### 4. Warning display

WARNING 02 1	CONDENSATION ON DRUM
--------------	----------------------

#### 5. Tape remaining time display

PLAY	00:00:00
CTL	00:00:00

#### On-screen display

On-screen information is available only via the rear panel [LINE 2 - SUPER OUT] connector.

#### 1. Tape counter display

- Shows data when the [ON SCREEN] switch on the sub panel is set to ON.
- You can choose what information is shown with menu switch No. 504 <INFORMATION SELECT>. Only time data is displayed when "TIME (0)" is selected. Both time data and VCR operation mode are displayed when "TIME + MODE (1)" is selected.
- The display position can be shifted horizontally with menu switch No. 501 <CHARA H.POSITION> and vertically with No. 502 <CHARA V.POSITION>.
- Set the [ON SCREEN] switch on the sub panel to OFF to turn off the on-screen display. \* If menu switch No. 513 <EDIT ON SCREEN> is set to "ON", you cannot turn the on-screen display off.
- When menu switch No. 504 <INFORMATION SELECT> is set to "TIME + SUB TC" or "TIME + SUB TC + MODE", sub time code information is shown simultaneously on a different line.

#### 2. Menu switch setting display

Press the [MENU] button to call up the menu setting display on screen.

- Select a menu item by turning the jog dial. For details, refer to "Menu switch setting" on page 31.
- Pressing the [MENU] button restores the normal display.

#### 3. Hour meter data display

Hour meter data can be displayed in the Menu Switch Setting mode. For details, refer to "Hour meter data display" on page 39.

#### 4. Warning code display

If a malfunction occurs, the corresponding warning code is automatically displayed. For details, refer to "Warnings with Indicators" on page 145.

#### 5. Tape remaining time display

When menu switch No. 505 <REMAIN ENABLE> is set to "ENABLE(1)", tape remaining time is shown in 6 steps.

- E ■■■■■ F Remaining time of 15 minutes or more
- E ■■■■ F Remaining time of less than 15 minutes
- E ■■■ F Remaining time of less than 10 minutes
- E ■■ F Remaining time of less than 5 minutes
- E ■ (blinking) F Remaining time of less than 2 minutes
- E (blinking) F Remaining time of less than 1 minutes
- No indication The remaining time is being calculated.

## 2 CONTROLS, CONNECTORS AND DISPLAYS

### 2-5 ON-SCREEN DISPLAY

#### Operation mode display in the Variable-motion mode

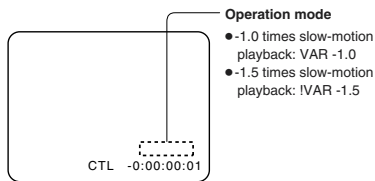

Noiseless slow-motion playback is available at speeds of -1.0 to +1.0 times normal.

- Variable-motion playback at speeds outside this range (from -1.0 times to +1.0 times) results in a distorted picture.
- When variable-motion playback is performed at speeds outside the range from -1.0 times to +1.0 times, "I" appears with the operation mode on the on-screen display.

#### MUTING/CONDITION ALARM display

The "MUTING" or "CONDITION ALARM" can be shown on screen to make it easy to check VCR operating status on the monitor connected to the [LINE 2 - SUPER OUT] connector.

- To display MUTING/CONDITION ALARM on screen, set menu switch No. 512 <MUTING/ALARM MESSAGE> to "ON (1)". This can also be displayed even when setting the [ON SCREEN] switch on the sub panel to OFF.

#### MUTING display

- This unit outputs black signals from the built-in signal generator via the <LINE 2 - SUPER OUT> connector.
  - In Record or EE mode: When no video signal is input or input signals do not contain a sync signal
  - In Play mode: When there are no recorded signals (no control signal recorded) on the tape being played back (With menu switch No. 120 <NO CTL MUTING> set to "ON")
- When the input signal is a black signal or when a tape on which a black signal is recorded is played back, the monitor's screen will be black.

To differentiate between the types of black screen described above, "MUTING" appears on the screen when the black screen is due to black signals output from the built-in signal generator.

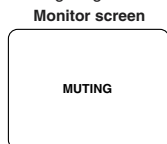

(Menu switch No. 512 <MUTING/ALARM MESSAGE> set to "ON (1)")

#### Editing screen display

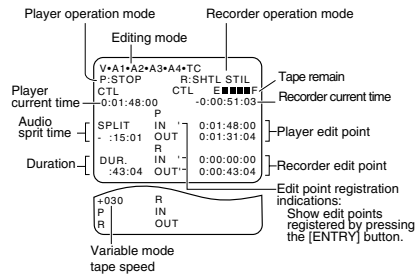

- Tape remain is shown when the remaining time is less than 25 minutes (approx.).
- This display automatically appears whenever an editing-related button is pressed (such as selecting the edit mode). (With menu switch No. 513 <EDIT ON SCREEN> set to "ON")
- When menu switch No. 513 <EDIT ON SCREEN> is set to "ON", press the [STANDBY] + [SHIFT] to switch the edit screen ON/OFF.

#### CONDITION ALARM display

If video head output (error rate) is degraded during playback, the "CONDITION ALARM" is shown on screen.

#### Monitor screen

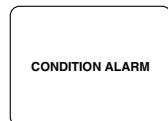

(Menu switch No. 512 <MUTING/ALARM MESSAGE> set to "ON (1)")

- When the "CONDITION ALARM" is displayed, perform manual tracking adjustment or cleaning with the dedicated head cleaning tape.

Error rate degradation can also be checked with the [CHANNEL CONDITION] indicator on the front panel (refer to page 22).

## 3 CONNECTIONS

### 3-1 INPUT CONNECTIONS

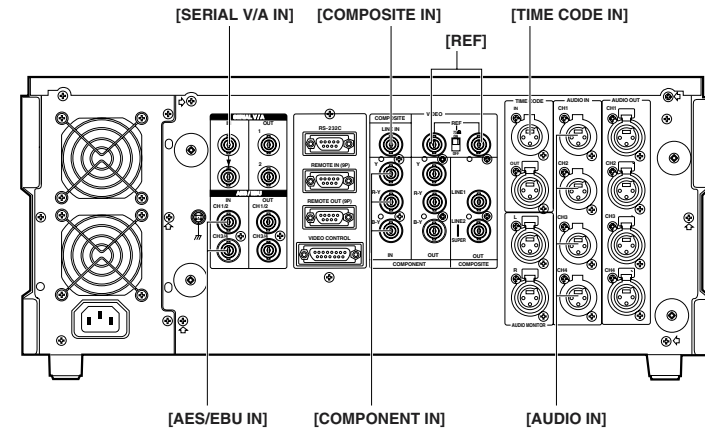

#### [SERIAL V/A IN]

Install the optional SA-D95U digital interface board to input signals to this connector.

#### [AUDIO IN]

Set the audio input reference level with menu switches No. 224 to 227 <AUDIO IN LEVEL>.

#### [COMPONENT IN]

Accepts component video signals.

#### [AES/EBU IN]

Install the optional SA-D95U digital interface board to input signals to this connector.

#### [TIME CODE IN]

To record the time code input from this connector, set the [INT/EXT] switch on the sub panel to "EXT" and menu switch No. 409 <EXT REGEN TC> to "LTC".

#### Digital signal synchronization

The input digital signal must be synchronized with the video signals. To do this, input sync signals to the digital signal output unit and the [REF] connector of this unit.

#### Reference sync signal

The servo system of this unit automatically selects the reference signal as shown in the table below depending on the setting of the menu switch and the operation.

Setting of menu switch N. 003 <SYNC SELECT>	Operation	Input sync signal	
		Video input	[REF] input
AUTO	Recording	○	×
	Playback	×	○
EXT	Recording	○	○
	Playback	×	○

- : Synchronizes (highest priority)
- : Synchronizes.
- ×

- If video input and [REF] input are not available, internal sync is performed.

### 3 CONNECTIONS

#### 3-2 OUTPUT CONNECTIONS

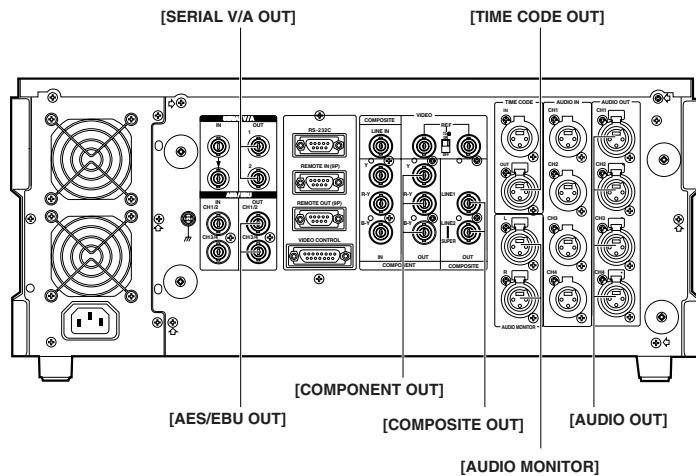

##### [SERIAL V/A OUT]

Install the optional SA-D95U digital interface board to output signals from this connector.

- All video parameter settings except SCH phase can be adjusted. (See page 119.)

##### [AUDIO OUT]

Set the audio output reference level with menu switches No. 228 to 231 <AUDIO OUT LEVEL>.

##### [TIME CODE OUT]

Select the time code output method during search with menu switch No. 452 <SEARCH LTC>.

##### [AUDIO MONITOR]

Set the audio output reference level with menu switches No. 232 and 233 <AUDIO MON LEVEL>.

##### [COMPOSITE OUT]

- On-screen data is output only to the [LINE 2 - SUPER] connector.
- Select the main time code or sub time code to output VITC with menu switch No. 451 <VITC OUT SELECT>.
- Video parameters can be adjusted. (See page 119.)

##### [COMPONENT OUT]

Set the component output level with menu switch No. 104 <COMPONENT LEVEL>.

- All video parameter settings except SCH phase can be adjusted. (See page 119.)

##### [AES/EBU OUT]

Install the optional SA-D95U digital interface board to output signals from this connector.

### 3 CONNECTIONS

#### 3-3 CONTROL SYSTEM CONNECTIONS

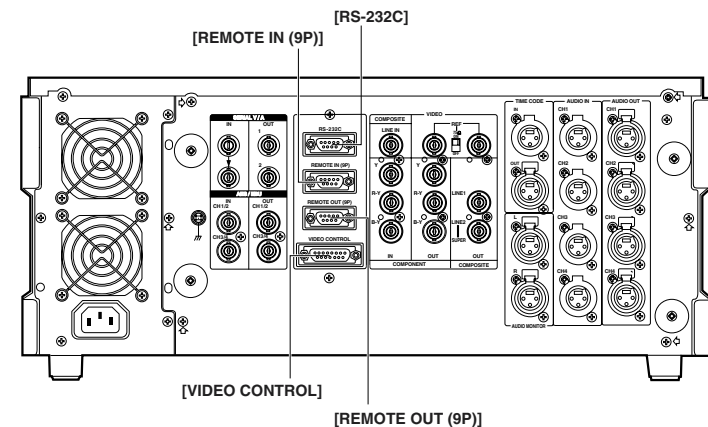

##### [REMOTE IN (9P)]

Connect an editing control for the RS-422 serial interface.

Editing controller menu setting switches are available. Menu switch No. 359 <JOG FEELING> Menu switch No. 363 <CONTROLLER SELECT> To control more than one VCR at the same time, set menu switch No. 369 <PARA-RUN> to "ON".

##### [RS-232C]

Connect to an RS-232C interface in a personal computer or other control unit.

##### [REMOTE OUT (9P)]

Connect another VCR with an RS-422 interface. You will be able to control the other VCR from this unit. To control more than one VCR at the same time, connect this connector to a [REMOTE IN] connector of the subsequent VCR.

##### [VIDEO CONTROL]

Connect an optional TBC remote control to operate the built-in TBC video controls. The RM-G22U cannot be connected.

When adjusting with a video controller, press the [VCON] button to select "Remote" and activate the settings. (Refer to "EDITING SYSTEM PHASE ADJUSTMENT" on page 117.)

##### Editing remote control connection

- Set the editing timing to -7 frames from the editing remote control.
- The preroll time should be set to 5 seconds or more.
- When using the RM-G820U or RM-G870U editing remote controller, execute the editing controller's learn function before operating. Otherwise, the number of retries will be increased.
- When the RM-G820 remote controller is connected to this unit, set the menu switch No. 317 <9PIN DEVICE ID > to "JVC D80". The remote controller's edit timing is automatically set to -7 frames.

## 4 MENU SWITCH SETTING

Besides the physical switches on the unit, a selection of MENU switches are provided. These can be displayed on the counter display or a connected monitor. Data set in the MENU switches are stored in the VCR's built-in nonvolatile memory and are not erased even when the main power is turned off.

Also available on the top menu display are the following convenient functions for menu switch setting.

- Storing and calling up the current menu switch setting
- Restoring the menu switches to the factory setting
- Calling up the Direct Access group of menu switches which are clustered by function (Direct Access facility)
- Erasing all registered contents on the User Page (User Page facility)
- Menu lock function

### 4-1 MENU DISPLAY MODES

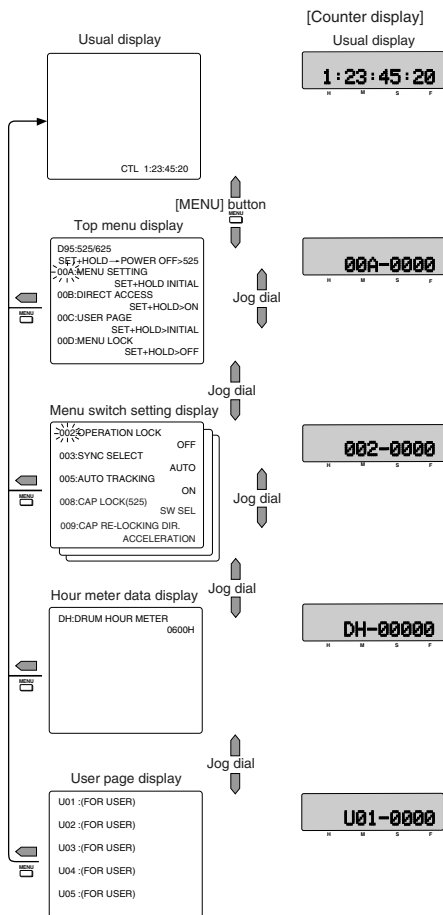

The menu display consists of four types of display modes.

- Press the [MENU] button to call up the menu screen. The menu switch Nos. are shown on the counter display. The selected menu switch No. blinks on the on-screen display.
- Turn the jog dial to call up all four modes one after another.
- Press the [MENU] button to restore the usual display.

#### 1 Top menu display

To select desired menu functions.

- **D95: 525/625**  
Set the video signal system to NTSC or PAL.  
525: NTSC signals  
625: PAL signals  
For details, refer to "4-2 VIDEO SIGNAL SYSTEM SELECTION" on page 30.
- **00A: MENU SETTING**
  - INITIAL(0) : Set the MENU switches to the factory settings.
  - USER-1 LOAD (1) : Set the MENU switches to USER-2 LOAD (3) the stored settings in the USER-3 LOAD (5) user memory area.
  - USER-1 SAVE (2) : To store the current menu USER-2 SAVE (4) switch setting in the user USER-3 SAVE (6) memory area.

For details, refer to "4-4 Saving and Calling Up Menu Switch Settings" on page 32.

- **00B DIRECT ACCESS (Direct Access facility)**  
With this switch set to ON (1), one-touch direct access to a functionally-related group of MENU switches such as SERVO and VIDEO or to the hour meter data or the Menu switches on user page is available simply by pressing the specified button on the control panel.

For details, refer to "4-5 Calling Up Functional Menu Switch (Direct Access Functions)" on page 33.

- **00C USER PAGE (user page facility)**  
Erases all registered menu switch settings. To do this, select this menu function and press the SET and [HOLD] buttons simultaneously.
- **00D MENU LOCK function (menu lock facility)**  
Locks or unlocks menu switch settings.  
OFF (0) : Settings can be changed.  
ON (1) : Locking function is activated and menu switch settings (except for the top menu) cannot be changed.

## 4 MENU SWITCH SETTING

### 4-1 MENU DISPLAY MODES

- **00E OPTIMUM REC CURRENT function (recording current automatic adjustment function)**  
To automatically adjust the recording current, select this menu function and press the [HOLD] and [REC] buttons simultaneously.  
For details, refer to "Recording current adjustment" on page 38.
- **00F FIXED TIME ENTRY**  
Sets the fixed time cue up point. To call up the setting mode, select this menu and press the [HOLD] button. For details, refer to "Fixed time cue up function" on page 91.

#### 2 MENU switch setting display

To access multiple menu switch items

The menu switches are organized in six functionally related groups.

- SERVO numbered 000
- VIDEO numbered 100
- AUDIO numbered 200
- SYSTEM numbered 300
- TIME CODE numbered 400
- ON-SCREEN numbered 500
- TBC/FRAME MEMORY numbered 600

#### 3 Hour meter display

Shows the drum running hours.

#### 4 User page display

Shows the menu switch data registered on the user page.

## 4 MENU SWITCH SETTING

### 4-2 VIDEO SIGNAL SYSTEM SELECTION

This unit can be used with either the NTSC or PAL signal systems. The currently selected video signal system is indicated by the 525/625 indicator on the counter display. To change the video signal system, follow the steps below.

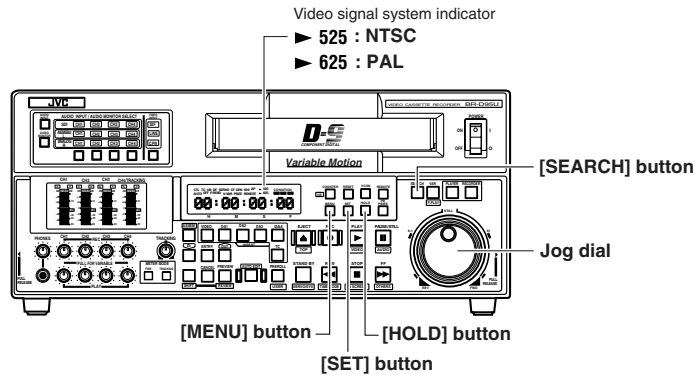

[Counter display]

D95-525

[On-screen display]

D95:525/625  
 SET+HOLD→POWER OFF→525  
 00A:MENU SETTING SET+HOLD INITIAL  
 00B:DIRECT ACCESS SET+HOLD-ON  
 00C:USER PAGE SET+HOLD-INITIAL  
 00D:MENU LOCK SET+HOLD-OFF

D95-625

D95:525/625  
 SET+HOLD→POWER OFF→525  
 00A:MENU SETTING SET+HOLD INITIAL  
 00B:DIRECT ACCESS SET+HOLD-ON  
 00C:USER PAGE SET+HOLD-INITIAL  
 00D:MENU LOCK SET+HOLD-OFF

#### Operation procedure

1. Press the [MENU] button to display the top menu.
2. Turn the jog dial to select "D95: 525/625". "D95" is shown on the counter display and "D95" blinks on screen.
3. Hold the [SEARCH] button down and turn the jog dial to select the set value. Select "525" for NTSC or "625" for PAL.
4. To change the menu switch setting, hold the [SET] button down and press the [HOLD] button.  
→ The Normal Display mode is restored.
5. To apply the selected video signal system, turn this unit OFF then ON again.  
→ When the power is turned ON, the video signal system is changed and the corresponding video signal system indicator is shown on the counter display (525 or 625 indicator).

- When a cassette tape recorded on a signal system other than that set for this unit is played back, the corresponding indicator ([525] or [625]) blinks. When the NTSC system is selected and a PAL tape is played back, the [625] indicator blinks. When the PAL system is selected and an NTSC tape is played back, the [525] indicator blinks.
- If required, select the audio reference level (-20 dB/-18 dB) for recording with menu switch No. 257 <AUD. REF. SIGNAL LEV. >. (See page 54.)

## 4 MENU SWITCH SETTING

### 4-3 MENU SWITCH SETTING

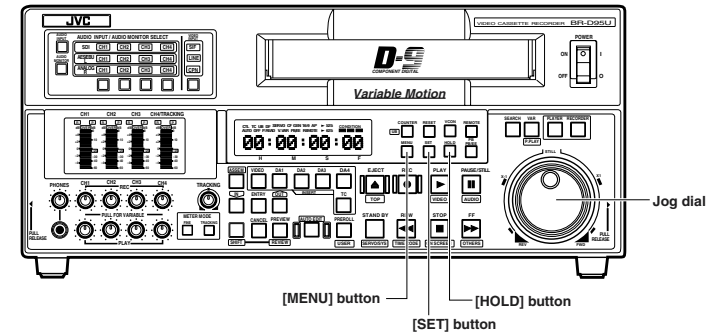

[Counter display]

00A-0000

[On-screen display]

Top menu display  
 D95:525/625  
 SET+HOLD→POWER OFF→525  
 00A:MENU SETTING SET+HOLD INITIAL  
 00B:DIRECT ACCESS SET+HOLD-ON  
 00C:USER PAGE SET+HOLD-INITIAL  
 00D:MENU LOCK SET+HOLD-OFF

Menu switch No. Set value No.

002-0000

Menu switch setting display

OPERATION LOCK OFF  
 003:SYNC SELECT AUTO  
 005:AUTO TRACKING ON  
 008:CAP LOCK(525) SW SEL  
 009:CAP RE-LOCKING DIR. ACCELERATION

300 0001

0300:DIRECT EJECT ON  
 301:DIRECT SEARCH ON  
 302:BACK SPACE ON  
 307:PAUSE/STILL/STP TIME 5MIN  
 311:AUTO PLAY OFF

300-0000

0300:DIRECT EJECT OFF  
 301:DIRECT SEARCH OFF  
 302:BACK SPACE ON  
 307:PAUSE/STILL/STP TIME 5MIN  
 311:AUTO PLAY OFF

#### Operation procedure

1. Call up the menu switch setting display. Press the [MENU] button to call up the menu screen on the counter display and on-screen display. When the top menu is displayed, turn the jog dial to show the menu switch setting screen.
  - On-screen display data are output through the rear panel [LINE2-SUPER] connector. The counter display shows menu switch number.
2. Select a menu switch item to set by turning the jog dial.
  - The selected menu switch number blinks on the on-screen display.
  - The menu switch number changes on the counter display.
3. Select the setting value of the menu switch by turning the jog dial while pressing the [SEARCH] button. Repeat steps 2 and 3 to change other items.
4. Press the [SET] button to enter the finalized settings in memory.
  - During setting, "SET" blinks on the counter display and "MENU SET" blinks on the on-screen display. When setting is complete, the normal screen is restored.



## 4 MENU SWITCH SETTING

### 4-4 SAVING AND CALLING UP MENU SWITCH SETTINGS

The set menu switch data can be saved and called up with the 00A MENU SETTING item on the top menu display.

If you're going to use the current menu switch setting again later, you can store it in the user memory area. Then, if the setting is changed, you can restore it simply by calling the stored user data.

It is also possible to restore the initial factory settings. The menu switch setting can be saved in USER-1 SAVE, USER-2 SAVE or USER-3 SAVE .

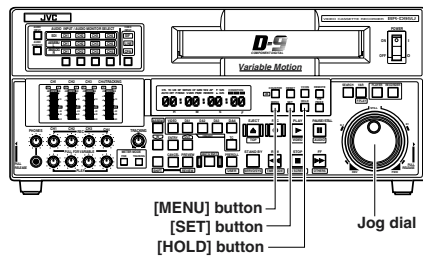

[Counter display] [On-screen display]

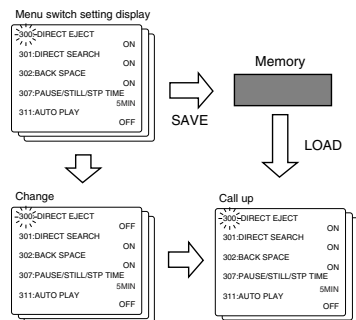
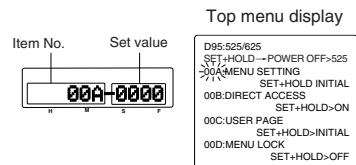

#### Operation procedure

1. Press the [MENU] button and turn the jog dial to call up the top menu on the on-screen display and the counter display.
2. Select 00A: MENU SETTING.
  - Turn the jog dial so that 00A appears on the counter display and 00A blinks on the on-screen display.
3. Select the saving or calling-up function and execute it.

#### When restoring the initial factory settings

- Select "INITIAL (0)" by turning the jog dial while pressing the [SEARCH] button.
- ↓
- Press the [HOLD] button while pressing the [SET] button.
- Factory settings are restored.  
→ The Normal Display mode is restored.  
\* The fixed time data is not changed.

#### To call up the saved menu setting

- (Recalling data stored in USER-1 SAVE )
- Select "USER-1 LOAD" by turning the jog dial while pressing the [SEARCH] button.
- ↓
- Press the [HOLD] button while pressing the [SET] button.
- The saved menu switch setting in "USER-1 SAVE" comes up.  
→ The Normal Display mode is restored.  
The data stored in USER-2 SAVE or USER-3 SAVE can be recalled using USER LOAD-2 or USER-3 LOAD , respectively.

#### To save the current menu switch setting

- (Storing data in USER-1 SAVE )
- Select "USER-1 SAVE" by turning the jog dial while pressing the [SEARCH] button.
- ↓
- Press the [HOLD] button while pressing the [SET] button.
- The current menu setting is stored in the user memory area. The data already saved is updated.  
→ The Normal Display mode is restored.

## 4 MENU SWITCH SETTING

### 4-5 CALLING UP FUNCTIONAL MENU SWITCH (Direct Access Function)

The Direct Access facility groups menu switches into major functionally related groups such as SERVO and VIDEO for easier access. These groups can be called up directly on the menu display. Hour meter data and User Page menu switches can also be accessed this way.

The Direct Access function can be turned on or off with 00B DIRECT ACCESS on the top menu display.

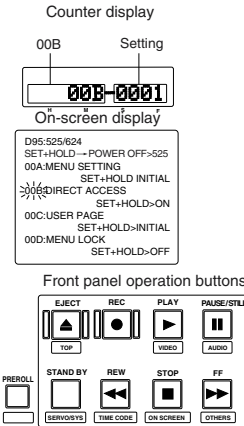

Access item	Control button	Information on display
TOP menu SW	EJECT	TOP menu
VIDEO menu SW	PLAY	Menu SW numbered 100 and 600
AUDIO menu SW	PAUSE/STILL	Menu SW numbered 200
SERVO/SYSTEM menu SW	STANDBY	Menu SW numbered 000 and 300
TC menu SW	REW	Menu SW numbered 400
ON-SCREEN menu SW	STOP	Menu SW numbered 500
Hour meter	FF	Drum running hours
User menu SW	PREROLL	Menu switch on the user page

The labels under the front panel control buttons indicate the functions that can be called up with the Direct Access facility.

#### Procedure

#### Enabling the Direct Access function

1. Press the [MENU] button and turn the jog dial to call up the top menu on the on-screen display and the counter display.
2. Turn the jog dial and select "00B DIRECT ACCESS".
  - Turn the jog dial so that "00B" appears on the counter display and "00B" blinks on the on-screen display.
3. Select "ON (1)" by turning the jog dial while pressing the [SEARCH] button.
4. Press the [HOLD] button while pressing the [SET] button.
 

The Direct Access function is set to ON.  
→ The Normal Display mode is restored.

To disable Direct Access, select "OFF (0)" by turning the jog dial while pressing the [SEARCH] button, then press the [HOLD] button while pressing the [SET] button.

#### Using the Direct Access function.

- Make sure the Direct Access function is set to "ON".
1. Press the [MENU] button to call up the menu setting display.
  2. Press the corresponding front panel control button, depending on the item. (Refer to the table on the left.)
 

→ The starting item is shown on the counter display and the first data appears on the on-screen display, depending on what has been selected.  
Move the items by turning the jog dial.

#### Page down function

When menu switches for a function are shown on more than one screen, you can display the menu screen by group with the Direct Access function. Then, each time the operation button corresponding to the same Direct Access function is pressed, the menu screens in the group can be advanced one screen at a time (page down function). (e.g.) When the [PLAY] button is pressed with the Direct Access function set to "ON", the top screen of menu switch #100 is shown. When the [PLAY] button is pressed again, the next menu screen is shown.

- If the group consists of one screen, the page down function cannot be used.

## 4 MENU SWITCH SETTING

### 4-6 USER PAGE REGISTRATION/CHANGE/DELETE (User page function)

Up to five menu switch settings can be registered on the user page (User Page function). The User Page function allows you to register frequently used menu switches for quicker access when you want to change the settings.

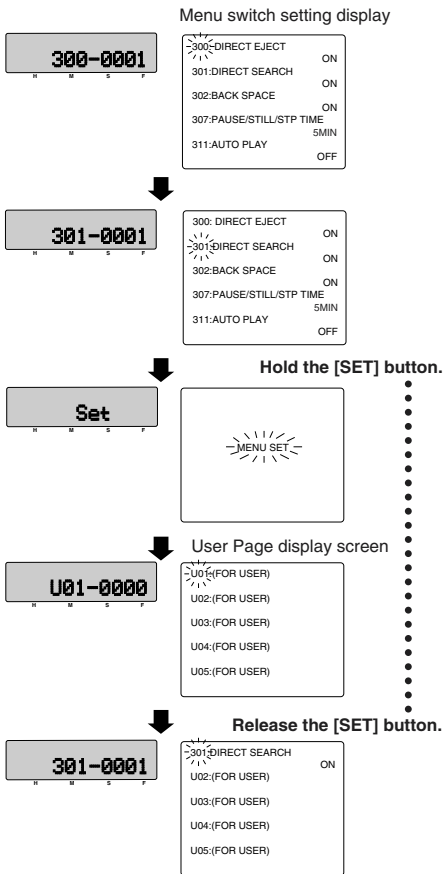

#### Procedure

##### Registering a menu switch on the User Page

- Call up the menu switch setting screen.**  
Press the [MENU] button.  
→ Call up the menu screen on the counter display and on-screen display. When the top menu is displayed, turn the jog dial to set to the menu switch setting screen.
- Turn the jog dial to select the menu switch you want to register.**  
Menu switch selection is also possible using the "Direct Access function".
- Press and hold the [SET] button.**  
During setting, "SET" blinks on the counter display and "MENU SET" blinks on the on-screen display.

While still keeping the [SET] button pressed (even after the [SET] indication goes out), execute the next operation.

- When the menu switch setting screen appears, turn the jog dial to access the User Page screen.**  
\*Memo: The User Page screen can be displayed using the Direct Access function. See page 33.
- Select the line you want to register on the User Page screen.**  
While keeping the [SET] button pressed, turn the jog dial to select the line number (U01 - U05) you want to register.  
→ The line number is displayed on the counter display; the line number blinks on the on-screen display.
- Release the [SET] button.**  
→ The menu switch setting is displayed and the selected line is registered on the User Page.
- To register more items, repeat steps 2 through 6.**  
Registration of up to five items is possible.
- To end User Page registration, press the [MENU] button. The normal display will be restored.**

- When steps 2 through 6 are performed on an already registered line, the new menu switch setting replaces the original line.
- Registered lines on the User Page can be moved. Select the menu switch you want to move and follow steps 3 through 6.
- Items D95,00A to 00E on the top menu and the DH:DRUM HOUR menu switch cannot be registered on the User Page.
- The menu registered on the User Page is reset when the unit is initialized (with menu switch 00A).

## 4 MENU SWITCH SETTING

### 4-6 USER PAGE REGISTRATION/CHANGE/DELETE (User page function) (con't)

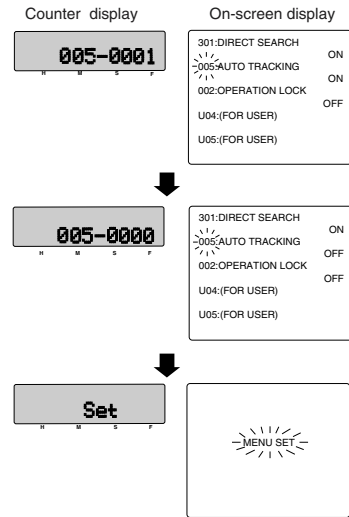

#### Procedure

##### Changing the registered menu switch setting

- Press the [MENU] button to call up the menu display mode.**
- Select the menu switch item to be changed with the jog dial.**
  - The selected menu switch number blinks on the on-screen display.
  - The menu switch number changes on the counter display.
- Select the setting value by turning the jog dial while pressing the [SEARCH] button.**
  - The counter display shows the setting value.
- To change additional items, repeat steps 2 to 3.**
- Press the [SET] button to register the new setting.**
  - During setting, "SET" blinks on the counter display and "MENU SET" blinks on the on-screen display. When setting is complete, the normal screen is restored.

## 4 MENU SWITCH SETTING

### 4-6 USER PAGE REGISTRATION/CHANGE/DELETE (User page function) (con't)

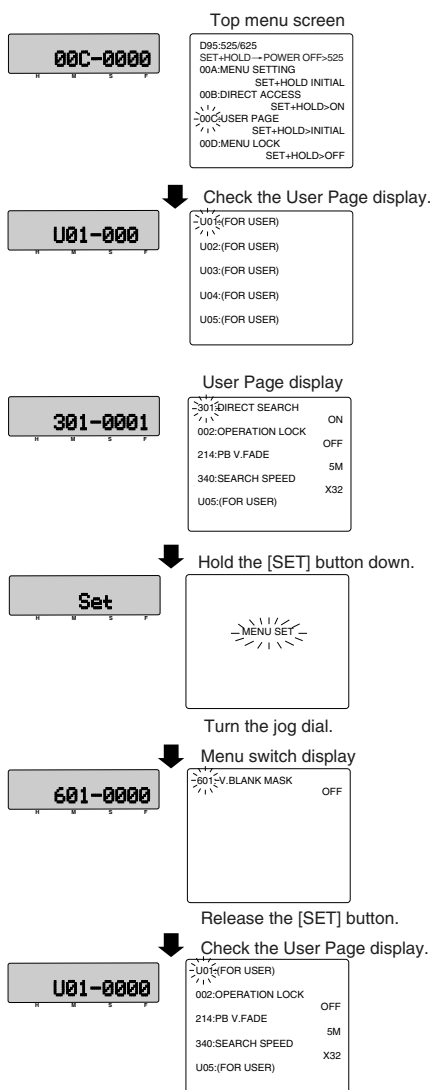

#### Procedure

##### Erasing all registered items on the User Page

1. Press the [MENU] button and turn the jog dial to call up the top menu.  
→ The top menu screen is shown on the on-screen display and counter display.
2. Select "00C USER PAGE" on the top menu.  
"00C" is shown on the counter display and "00C" blinks on the on-screen display.
3. While keeping the [SET] button pressed, press the [HOLD] button.  
→ All registered items on the User Page are erased and the display returns to the normal display mode.

##### Erasing registered items one at a time

1. Press the [MENU] button to select the Menu Switch Display mode.  
\* The selected menu switch number blinks on the on-screen display.  
\* The menu switch number is changed on the counter display.
2. Turn the jog dial to access the User Page display and select the menu switch item to be erased.
3. Hold the [SET] button pressed.  
→ During setting, "SET" is shown on the counter display and on-screen display.

While still keeping the [SET] button pressed (even after the "SET" indication goes out), perform the next operation.

4. Turn the jog dial to move to the other menu switch screen page. Release the [SET] button.  
→ The registered item on the User Page is erased.
5. To erase more items, repeat steps 2 through 4.
6. Press the [MENU] button to finish.  
→ The normal display mode is restored.

## 4 MENU SWITCH SETTING

### 4-7 HOW TO LOCK THE MENU SWITCH SETTINGS (Menu switch lock function)

To prevent accidental erasure of menu switch settings, you can lock the menu switch settings. This function is not the same as operation lock.

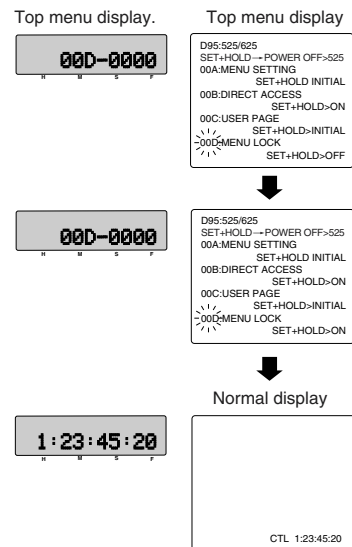

#### Procedure

##### Activating the menu switch lock function

1. Press the [MENU] button and turn the jog dial to call up the top menu.  
→ The top menu screen is shown on the on-screen display and counter display.
2. Select "00D: MENU LOCK" on the top menu with the jog dial.  
"00D" is shown on the counter display and "00D" blinks on the on-screen display.
3. Select "ON (1)" by turning the jog dial while pressing the [SEARCH] button.
4. While keeping the [SET] button pressed, press the [HOLD] button.  
→ The menu switch lock function is set to "ON" and the normal display is restored.

To disable the menu switch lock function, select "OFF (0)" by turning the jog dial while pressing the [SEARCH] button. Then, while keeping the [SET] button pressed, press the [HOLD] button.

**When the menu switch lock function is activated, only the top menu settings can be changed. All other settings are locked.**

## 4 MENU SWITCH SETTING

### 4-8 RECORDING CURRENT ADJUSTMENT

Thanks to this function, it is not necessary to adjust the recording current each time the tape is changed. When a tape with a different optimum recording current is used, this function allows you to take advantage of this tape's performance. If automatic adjustment is performed on a tape which has been used many times, its optimum recording current may be quite different from that of a new tape. In this case, perform automatic adjustment using the new tape.

#### Procedure

##### Activating the recording current adjustment function

1. Light all [VIDEO INPUT] indicators with the input video signal switch.
  2. Select the PB/EE Auto Switching mode with the [PB PB/EE] button.
  3. Load a recording tape and engage the Stop mode.
  4. Press the [MENU] button and turn the jog dial to call up the top menu.
    - The top menu screen is shown on the on-screen display and counter display.
  5. Select "00E:OPTIMUM REC CURRENT" on the top menu with the jog dial.
    - "00E" is shown on the counter display and "00E" blinks on the on-screen display.
  6. While keeping the [REC] button pressed, press the [HOLD] button.
    - Automatic recording current adjustment will start. It takes several minutes to complete the automatic adjustment.
    - To interrupt the adjustment, press the [MENU] button twice.
    - When adjustment is finished, the indication shown on the left is displayed on the on-screen display.
  7. When the indication on the left figure is shown on the on-screen display, press the [MENU] button twice.
    - The previous display mode is restored.
- When the adjustment cannot be completed, the indication shown on the left is displayed on the on-screen display. In this case, change the recording position or replace the recording tape.

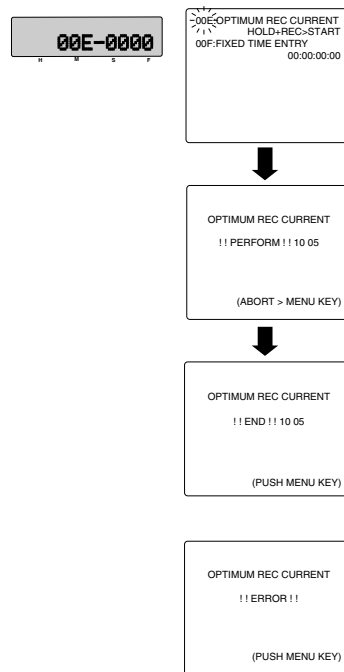

## 4 MENU SWITCH SETTING

### 4-9 HOUR METER DATA DISPLAY

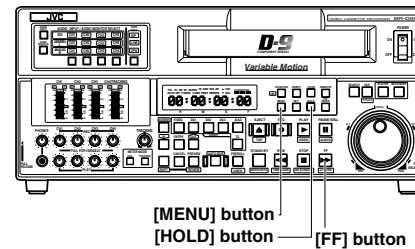

Drum running hours can be displayed on the counter display and the on-screen display. Use this information as a guide to choosing the appropriate maintenance interval.

#### Procedure

1. Press the [MENU] button.
  - The Menu Display mode is engaged.
2. Select the DH display by turning the jog dial.
  - Hour meter data (drum running hours) is displayed on the counter display and the on-screen display (0000H - 9999 H).
3. To return to the normal display mode, press the [MENU] button.

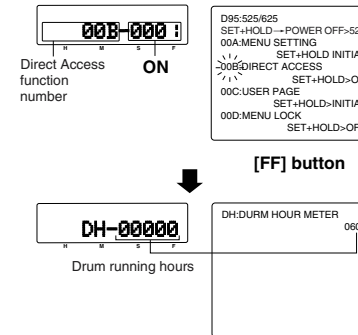

When the Direct Access function is set to ON, press the [FF] button to accelerate item indication.

# 5 MENU SWITCH SETTING DETAILS

## 5-1 MENU SWITCH LIST

Gives the names and brief description of the menu switches. See reference pages for details  
 Functions enclosed in   are not available on the PAL system.

Functional group	No	Names	Description	Reference Page
SERVO	002	OPERATION LOCK	Operation mode lock ON/OFF .....	43
	003	SYNC SELECT	Selects the reference sync signal (EXT or AUTO) for the servo system .....	43
	005	AUTO TRACKING	Selects automatic or manual tracking .....	43
	008	CAP LOCK (525)	Selects the color frame servo sync system .....	43
	008p	CAP LOCK (625)	Selects the color frame servo sync system .....	44
	009	CAP RELOCKING DIR	Selects the color frame servo lock direction .....	44
VIDEO	104	CPN LEVEL/SETUP (525)	Selects Betacam or MII component level .....	44
	111	VD REC SIGNAL SEL.	Selects the video signal created by internal generator .....	44
	112	ECC MODE	Selects level of error correction .....	45
	119	SLOW PICTURE	Selects FIELD or FRAME slow motion playback mode .....	45
	120	NO CTL MUTING	Selects if the video output mutes when playing back a blank tape .....	45
	124	CHROMA ROTATE	Selects the output chroma phase reference signal .....	45
	128	PB EXTENSION LINE	Selects the extension line output during playback .....	45
	130	BLANKING WIDTH	Selects the H blanking width .....	46
	133	LINE SETUP (525)	Adds setup to composite signals .....	46
	138	EXTRA LINE REC (525)	Selects the video signal that will be recorded on the extra line .....	47
	139	EXTRA-L R1 SEL (525)	Selects the input signal line that will be recorded on extra line 1 .....	47
	140	EXTRA-L R2 SEL (525)	Selects the input signal line that will be recorded on extra line 2 .....	47
	141	EXTRA-L R3 SEL (525)	Selects the input signal line that will be recorded on extra line 3 .....	47
	142	EXTRA-L R4 SEL (525)	Selects the input signal line that will be recorded on extra line 4 .....	47
	143	EXTRA LINE PB (525)	Selects how extra line information is added during playback .....	47
	144	EXTRA-L P1 SEL (525)	Selects which line to add extra line 1 information .....	48
	145	EXTRA-L P2 SEL (525)	Selects which line to add extra line 2 information .....	48
	146	EXTRA-L P3 SEL (525)	Selects which line to add extra line 3 information .....	48
	147	EXTRA-L P4 SEL (525)	Selects which line to add extra line 4 information .....	48
	138p	EXTRA LINE REC (625)	Selects the video signal that will be recorded on the extra line .....	48
	139p	EXTRA-L R1 SEL (625)	Selects the input signal line that will be recorded on extra line 1 .....	48
	140p	EXTRA-L R2 SEL (625)	Selects the input signal line that will be recorded on extra line 2 .....	48
	141p	EXTRA-L R3 SEL (625)	Selects the input signal line that will be recorded on extra line 3 .....	48
	142p	EXTRA-L R4 SEL (625)	Selects the input signal line that will be recorded on extra line 4 .....	48
	143p	EXTRA LINE PB (625)	Selects how extra line information is added during playback .....	49
	144p	EXTRA-L P1 SEL (625)	Selects which line to add extra line 1 information .....	49
	145p	EXTRA-L P2 SEL (625)	Selects which line to add extra line 2 information .....	49
	146p	EXTRA-L P3 SEL (625)	Selects which line to add extra line 3 information .....	49
	147p	EXTRA-L P4 SEL (625)	Selects which line to add extra line 4 information .....	49
	148	IN VBLANK YCOMB (525)	Turns Y/C separation ON/OFF for composite signals in the V. Blanking period .....	49
	148p	IN VBLANK YCOMB (625)	Turns Y/C separation ON/OFF for composite signals in the V. Blanking period .....	49
	149	VIDEO OUT SELECT	Selects the timing for output video signals during editing .....	50
	AUDIO	214	PB V. FADE	Enables V fades during playback at the audio edit transitions .....
215		AUD REC VOLUME MODE 1	Selects audio REC level adjustment as individual channels or stereo pairs .....	50
216		AUD PB VOLUME MODE 1	Selects audio PB level adjustment as individual channels or stereo pairs .....	51
219		SEARCH REC CH	Selects the signal source for recording linear audio tracks .....	51
221		SEARCH PB AT 1+3/2+4	Switches the linear track audio ON/OFF during search .....	51
222		MONITOR MIX MODE	Selects the audio monitor mixing level .....	51
223		CH3/4 OUT SEL AT 2CH	Selects the signal output from the CH3/CH4 audio channels .....	52
224		AUDIO IN LEVEL CH1	Sets the audio input reference level for CH1 .....	52
225		AUDIO IN LEVEL CH2	Sets the audio input reference level for CH2 .....	52

# 5 MENU SWITCH SETTING DETAILS

## 5-1 MENU SWITCH LIST

Functional group	No	Names	Description	Reference Page
AUDIO	226	AUDIO IN LEVEL CH3	Sets the audio input reference level for CH3 .....	52
	227	AUDIO IN LEVEL CH4	Sets the audio input reference level for CH4 .....	52
	228	AUDIO OUT LEVEL CH1	Sets the audio output reference level for CH1 .....	52
	229	AUDIO OUT LEVEL CH2	Sets the audio output reference level for CH2 .....	52
	230	AUDIO OUT LEVEL CH3	Sets the audio output reference level for CH3 .....	52
	231	AUDIO OUT LEVEL CH4	Sets the audio output reference level for CH4 .....	52
	232	AUDIO MON LEVEL LCH	Sets the output reference level for the LCH audio monitor .....	52
	233	AUDIO MON LEVEL RCH	Sets the output reference level for the RCH audio monitor .....	52
	236	PRO 48K S.R.CONV.	Enables the sampling rate converter even when the input signal is a professional 48K AES/EBU signal .....	52
	237	EMBEDDED AUDIO	Disables the embedded audio signal from the SDI output signal .....	53
	247	DIG AUD AT SYNC IN	Turns the embedded audio noise ON/OFF when the sync signal is input from a different system .....	53
	251	CH3/4 SOURCE SEL	Selects the input source for the CH3 and CH4 audio signals .....	53
	253	CH1 REC SIGNAL SEL	Selects the built-in signal generator's CH1 audio signal .....	54
	254	CH2 REC SIGNAL SEL	Selects the built-in signal generator's CH2 audio signal .....	54
255	CH3 REC SIGNAL SEL	Selects the built-in signal generator's CH3 audio signal .....	54	
256	CH4 REC SIGNAL SEL	Selects the built-in signal generator's CH4 audio signal .....	54	
257	AUD REF. SIGNAL LEV	Selects the audio recording reference level .....	54	
261	AUD SEL. AT SEARCH	Selects the output audio track during search .....	54	
SYSTEM	300	DIRECT EJECT	Enables /disables direct EJECT (accepts EJECT command from any mode) .....	54
	301	DIRECT SEARCH	Direct search ON/OFF .....	54
	302	BACK SPACE	Back space edit operation ON/OFF .....	54
	307	PAUSE/STILL/STP TIME	Selects duration of long-time pause/still/standby ON .....	55
	311	AUTO PLAY	Auto play operation ON/OFF .....	55
	312	AUTO REW	Auto rewind operation ON/OFF .....	55
	314	PB/EE MODE	Selects the modes in which the VCR automatically switches from PB to EE .....	55
	317	9PIN DEVICE ID	Selects the device type ID returned to a 9-pin remote control .....	55
	319	FF/REW MAX SPEED	Selects the maximum tape speed in FF/REW modes .....	55
	320	PREROLL TIME	Sets the PREROLL time .....	56
	323	PREROLL END MODE	Selects the mode engaged after preroll operation .....	56
	328	EDIT POINT CLEAR	Selects whether the edit point data is cleared after performing the edit .....	56
	340	SEARCH SPEED	Selects the maximum search speed when using the search dial .....	56
	351	PREREAD	Selects the video/audio preread function .....	56
	352	AUD PREREAD TIMING	Selects the output audio phase correction during audio preread .....	56
	357	DIAG AT POWER ON	Enables/disables automatic diagnosis operation at power ON .....	57
	359	JOG FEELING (REMOTE)	Selects the "feel" of an external editing /remote controller's JOG dial .....	57
	363	CONTROLLER SELECT	Changes the personality of the VCR to match the type of editing controller connected .....	57
	367	EDIT INTERRUPTION	Enables/disables channel condition monitoring during editing .....	57
	368	STARTING PIC FREEZE	Selects video output source (freeze or tape) during servo lock .....	57
369	PARA-RUN	Enables simultaneous control of multiple VCR's from a single remote .....	58	
371	INPUT SELECT SAFETY	Switches ON a safety function to prevent accidental change of input router ...	58	
372	P+R AT SWAP MODE	Selects whether or not simultaneous operation of the player and recorder is permitted .....	58	
373	MATCH FRAME	Switches the match frame mode ON/OFF during swap editing .....	58	
374	MENU OPEN SAFETY	Selects the method for opening the menu switch setting mode .....	58	
375	AUD EDIT PRESET CH1	Selects the ON/OFF execution command for the (DA-1) Insert mode .....	59	
376	AUD EDIT PRESET CH2	Selects the ON/OFF execution command for the (DA-2) Insert mode .....	59	
377	AUD EDIT PRESET CH3	Selects the ON/OFF execution command for the (DA-3) Insert mode .....	59	
378	AUD EDIT PRESET CH4	Selects the ON/OFF execution command for the (DA-4) Insert mode .....	59	

## 5 MENU SWITCH SETTING DETAILS

### 5-1 MENU SWITCH LIST

Functional group	No	Names	Description	Reference Page	
SYSTEM	381	JOG FEELING (LOCAL)	Selects jog dial operation response level .....	59	
	382	9 PIN ID- (1ST)	Sets the first digit of the ID code .....	59	
	383	9 PIN ID- (2ND)	Sets the second digit of the ID code .....	59	
	384	9 PIN ID- (3RD)	Sets the third digit of the ID code .....	59	
	385	9 PIN ID- (4TH)	Sets the fourth digit of the ID code .....	59	
	386	MUTING AT NO TAPE	ON/OFF of the EE signal output when no tape is loaded .....	59	
	387	CF FLAG REPLY (525)	Selects the number of fields for which the color frame flag is set for 9-pin remote control .....	60	
	387p	CF FLAG REPLY (625)	Selects the number of fields for which the color frame flag is set for 9-pin remote control .....	60	
	389	MULTI CUE MODE	Switches Multi Cue mode ON/OFF .....	60	
	390	SWAP VTR SELECT	Enables/disables the bump mode during swap editing .....	60	
	391	SYNCHRONIZATION	Selects the editing accuracy during swap editing .....	60	
	393	SYNC GRADE	Selects whether the BR-D92 automatically switches to EE for single monitor operation during swap editing .....	60	
	395	AUTO-EE	.....	60	
	TIME CODE	400	VITC LINE-1 SEL (525)	Selects the vertical interval line for adding VITC-1 .....	61
		400p	VITC LINE-1 SEL (625)	.....	61
		401	VITC LINE-2 SEL (525)	Selects the vertical interval line for adding VITC-2 .....	61
401p		VITC LINE-2 SEL (625)	.....	61	
402		CTL DF SELECT (525)	Sets the CTL counter to operate in NONDROP/DROP frame mode .....	61	
403		REGEN MODE	Selects what elements of time the code (TC, UB) are regenerated .....	61	
409		EXT REGEN TC	Selects external source (LTC/ VITC) for regeneration .....	62	
410		AUTO REGEN MODE	Selects the edit mode in which time code is regenerated. ....	62	
421		TCG CF FLAG	Turns the color frame flag ON/OFF for the time code bit .....	62	
450		SUB TC (VITC) REC	Selects whether incoming VITC is recorded onto the Sub-Time Code .....	62	
451		VITC OUT SELECT	Selects the VITC time code output source (Main/Sub) time code .....	62	
452	SEARCH LTC	Selects whether LTC time code is output in the Search mode .....	62		
457	UB PRESET AUTO	Selects if the user bit data stored in the memory is recorded preferentially .....	63		
ON-SCREEN	501	CHARA H POSITION	Sets the horizontal display position of the on-screen data .....	63	
	502	CHARA V POSITION	Sets on-screen data vertical display position .....	63	
	504	INFORMATION SELECT	Selects the type of information shown by the on-screen display .....	63	
	505	REMAIN ENABLE	Enables/ disables the tape "Remaining Time" display indication .....	63	
	512	MUTING/ALARM MESSAGE	Selects whether "MUTING" or "CONDITION ALARM" appears on-screen .....	64	
513	EDIT ON SCREEN	ON/OFF of edit on-screen display .....	64		
TBC.FRAME MEMORY	601	V.BLANK MASK	Turns the V sync section masking ON/OFF during playback .....	64	
	620	DUBBING LOOP	Enables/ disables the Dubbing Loop (multi-gen test) function .....	64	

## 5 MENU SWITCH SETTING DETAILS

### 5-2 MENU SWITCH SETTING CONTENT

When the contents of a menu item differ for NTSC and PAL, this is indicated after the menu item name by (525) for NTSC and (625) for PAL. With PAL, "p" is shown after the menu No.

<SERVO> [ ] : Factory setting Functions enclosed in [ ] are not available on the PAL SYSTEM.

Menu SW No.	Item	Setting		Content
		On-screen display	Counter display	
002	OPERATION LOCK	[0] 1	[OFF] ON	Switches the operation mode lock ON/OFF. Set to ON to lock the VCR in the current mode. When "OPERATION LOCK" is ON, you cannot operate the control buttons, switches, knobs and dials on the VCR or change any menu switch settings other than this menu switch itself. Only the [POWER] switch and the [PHONES LEVEL] adjust knob remain operable.
003	SYNC SELECT	1 [3]	EXT [AUTO]	Selects the reference sync signal used by the servo system. EXT : Synchronizes with the signal applied to the [REF] input connector regardless of VCR mode (playback or record). AUTO : Synchronizes with the signal applied to the [REF] input connector during playback. The VCR locks to the video input during recording. (If no signal is present on the [REF] connector and video input connector, the VCR synchronizes to an internal clock signal regardless of this menu's setting).
005	AUTO TRACKING	0 [1]	OFF [ON]	Selects manual or automatic tracking adjustment in the Play mode. ON : The tracking value is automatically adjusted to the optimum position when the Play mode is engaged. The [TRACKING] knob is not operable. When the Automatic Tracking mode is engaged, tracking adjustment takes several seconds. During this time, audio output signals are derived from the linear tracks. OFF : Tracking can be adjusted manually with the [TRACKING] knob. When the meter indication is set to "Tracking", the [TRACKING] button blinks.
008	CAP LOCK (525)	[0] 1 2	[SW SEL] 2 FIELD 4 FIELD	Selects the color frame servo sync system for NTSC signals. SW SEL : The color frame servo setting is determined by the sub panel's [CF] switch setting. 2 FIELD : The frame servo is set. Color framing is not executed. 4 FIELD : 4 field color frame servo is executed.

## 5 MENU SWITCH SETTING DETAILS

### 5-2 MENU SWITCH SETTING CONTENT

[ ] : Factory setting

Menu SW No.	On-screen display	Setting		Content
		Counter display	On-screen display	
008p	CAP LOCK (625)	[0] 1 2 3	[SW SEL] 2 FIELD 4 FIELD 8 FIELD	Selects the color frame servo sync system for PAL signals. SW SEL : The color frame servo setting is determined by the sub panel's [CF] switch setting. 2 FIELD : The frame servo is set. Color framing is not executed. 4 FIELD : 4 field color frame servo is executed. 8 FIELD : 8 field color frame servo is executed.
009	CAP RE-LOCKING DIR.	[0] 1	[ACCELERATION] DECELERATION	Selects the color frame servo lock direction after executing the bump function. If the edit point shifts due to the color frame servo, select + or - to adjust the edit point. ACCELERATION : Moves the edit point in the + direction (locks in the acceleration direction). DECELERATION : Moves the edit point in the - direction (locks in the deceleration direction).
<VIDEO>				
104	CPN LEV./SETUP (525)	0 [1] 2 3	LOW/ON [HIGH/ON] LOW/OFF HIGH/OFF	This item should be applied to NTSC signals only. Sets input/output levels for the [Y, R-Y, B-Y] connectors on the rear panel. Sets input/output levels and setup presence. LOW/ON : Sets component signals to MII levels with setup. HIGH/ON : Sets component signals to Bcam levels with setup. LOW/OFF : Sets component signals to MII levels without setup. HIGH/OFF : Sets component signals to Bcam levels without setup.
111	VD REC SIGNAL SEL.	1 [2] 4 5	COLOR BAR [BLACK] MULTI BURST PULSE & BAR	Selects the video signal output by the internal signal generator. The selected signal is output in the EE and Record modes. These signals do not conform to the SMPTE standard. COLOR BAR : Color bar is selected. (These are 75% color bar signals). BLACK : Black signal is selected. MULTI BURST : Multi Burst signal is selected. PULSE & BAR : Pulse & Bar signal is selected.

## 5 MENU SWITCH SETTING DETAILS

### 5-2 MENU SWITCH SETTING CONTENT

[ ] : Factory setting

Menu SW No.	On-screen display	Setting		Content
		Counter display	On-screen display	
112	ECC MODE	[0] 1 2	[NORMAL] NO CANCEL NO CORRECTION	This menu activates or deactivates the error correction circuit (error correction /error conceal). NORMAL : Activates all error correction circuitry. NO CONCEAL : NO error concealment is applied NO CORRECTION: Neither the error concealment nor the error correction circuits function. For details, refer to page 80.
119	SLOW PICTURE	0 [1]	FRAME [FIELD]	Selects the "Field" or "Frame" slow play mode. FRAME : Outputs a frame picture. FIELD : Outputs a field picture.
120	NO CTL MUTING	0 [1]	OFF [ON]	Selects the video signal output when a non-recorded section (NO CTL) of the tape is played back. OFF : Still picture is output. ON : Black picture is output.
124	CHROMA ROTE	[0] 1	[CPS] CPN	Switches the output chroma phase reference for component signals or composite signals. CPS : Varies the phase so that the chroma level is not changed with the composite vector scope. CPN: Varies the phase so that the chroma level is not changed with the component vector scope. Set this switch when adjusting the chroma phase with the video control.
128	PB EXTENSION LINE	0 [1]	OFF [ON]	Sets whether or not the video signal extension line is output during playback. ON : Outputs the extension line. When a tape recorded on this unit is played back, all video signal lines are output. OFF : Does not output the extension line. Set to this position when playing back tapes not recorded on this unit. *During recording, the following signal lines are recorded as the EXTENSION LINE. [525]: LINE 20, 21, 22, 263, 282, 283, 284 and 525 (For LINE 282, the second half only) [625]: LINE 19, 20, 21, 22, 331, 332, 333, 334 and 623 This menu functions only with tapes recorded on this unit. When a tape recorded on this unit is played back on the BR-D80, BR-D750, BR-D92 or BR-D860, the EXTENSION LINE is not played back. For details, refer to page 89.

## 5 MENU SWITCH SETTING DETAILS

### 5-2 MENU SWITCH SETTING CONTENT

[ ] : Factory setting

Menu SW No.	Item		Setting		Content
	On-screen display	Counter display	On-screen display	Counter display	
130	BLANKING WIDTH	[0] 1	[WIDE] NARROW		Selects the video signal H blanking width. WIDE : H blanking width is set to the blanking width used by analog video signals. NARROW : H blanking width is set to the blanking width used by digital video signals. Use this position for digital video signal dubbing.
133	LINE SETUP (525)	0 [1]	OFF [ON]		Selects whether or not setup should be added to composite signals (NTSC only). OFF : Setup is not added. ON : Adds setup.

## 5 MENU SWITCH SETTING DETAILS

### 5-2 MENU SWITCH SETTING CONTENT

[ ] : Factory setting

Menu SW No.	Item		Setting		Content
	On-screen display	Counter display	On-screen display	Counter display	
138	EXTRA LINE REC (525)	[0] 1 2	[FIX] USER (COLOR) USER (MONO)		<p>Sets the input video signal line whose data will be recorded on the extra line. Selects the fixed line or user-set line.</p> <p>FIX: Records the information from line 22 onto extra line-1 and the information from line 284 onto extra line-2 in the Color mode.</p> <p>USER (COLOR): Records the information from 2 specified lines onto extra line-1 and line-2 in the Color mode.</p> <p>Specify the lines with menu switches No. 139 and No. 140.</p> <p>USER (MONO) : Records the information from 4 specified lines onto extra lines 1 to 4 in the Black and White mode.</p> <p>Specify the lines with menu switches No. 139 to No. 142.</p> <p>* When a recording is made with this menu switch set to "USER (MONO)", extra line data cannot be played back normally on the BR-D50/D51/D52/D80/D92/D350/D750/D860.</p>
139	EXTRA-L R1 SEL (525)	01 ⋮ 11	11 ⋮ 21		<p>Sets video signal lines that will be recorded on extra line 1, 2, 3 or 4.</p> <p>It is possible to set each extra line independently.</p> <ul style="list-style-type: none"> <li>•No. 139 &lt;EXTRA-L R1 SEL&gt; ... Sets extra line 1.</li> <li>•No. 140 &lt;EXTRA-L R2 SEL&gt; ... Sets extra line 2.</li> <li>•No. 141 &lt;EXTRA-L R3 SEL&gt; ... Sets extra line 3.</li> <li>•No. 142 &lt;EXTRA-L R4 SEL&gt; ... Sets extra line 4.</li> </ul> <p>Select 1 line from lines 11 to 22 and 273 to 284 for each extra line.</p> <p>* Extra lines 3 and 4 are effective only when menu switch No. 138 &lt;EXTRA LINE REC (525)&gt; is set to "USER (MONO)".</p>
140	EXTRA-L R2 SEL (525)	12 18 ⋮ 28	22 273 ⋮ 283		
141	EXTRA-L R3 SEL (525)	28 29	283 284		
142	EXTRA-L R4 SEL (525)		[First setting] No. 139 ... 22 No. 140 ... 284 No. 141 ... 21 No. 142 ... 283		
143	EXTRA LINE PB (525)	[0] 1 2	[MUTING] AUTO USER SETTING		<p>Selects how extra line signal data is added to the playback video signal during playback.</p> <p>MUTING : Line data is not added to the playback video signal.</p> <p>AUTO : Extra line data is added to the line selected for extra line recording.</p> <p>USER SETTING: Extra line data is added to the four lines specified by the user. Lines can be selected with menu switches No. 144 to No. 147.</p>



## 5 MENU SWITCH SETTING DETAILS

### 5-2 MENU SWITCH SETTING CONTENT

[ ] : Factory setting

Menu SW No.	On-screen display	Setting		Content
		Counter display	On-screen display	
144	EXTRA-L P1 SEL (525)	00 ⋮ 11	10 ⋮ 21	<p>Selects the playback video signal line to add signal data recorded on extra line 1, 2, 3 or 4 for output. Effective only when menu switch No. 143 &lt;EXTRA LINE PB&gt; is set to "USER SETTING".</p> <ul style="list-style-type: none"> <li>•No. 144 &lt;EXTRA-L P1 SEL&gt; ... Sets extra line 1.</li> <li>•No. 145 &lt;EXTRA-L P2 SEL&gt; ... Sets extra line 2.</li> <li>•No. 146 &lt;EXTRA-L P3 SEL&gt; ... Sets extra line 3.</li> <li>•No. 147 &lt;EXTRA-L P4 SEL&gt; ... Sets extra line 4.</li> </ul> <p>Select 1 line from lines 10 to 22 and 273 to 284 for each extra line.</p> <p>* When the information such as time code data is superimposed on the same line, extra line data is not output.</p>
145	EXTRA-L P2 SEL (525)	12 18 ⋮ 28	22 273 ⋮ 283	
146	EXTRA-L P3 SEL (525)	28 29	284	
147	EXTRA-L P4 SEL (525)		[First setting] No. 144 ... 22 No. 145 ... 284 No. 146 ... 21 No. 147 ... 283	
138p	EXTRA LINE REC (625)	[0] 1 2	[FIX] USER (COLOR) USER (MONO)	
139p	EXTRA-L R1 SEL (625)	00 ⋮ 15	6 ⋮ 21	<p>Sets the input video signal line whose data will be recorded on the extra line. Selects the fixed line or user-set line.</p> <p>FIX : Records the information from line 22 onto extra line-1 and the information from line 623 onto extra line-2 in the Color mode.</p> <p>USER (COLOR) : Records the information from 2 specified lines onto extra line-1 and line-2 in the Color mode. Specify the lines with menu switches No. 139p and No. 140p.</p> <p>USER (MONO) : Records the information from 4 specified lines onto extra lines 1 to 4 in the Black and White mode. Specify the lines with menu switches No. 139p to No. 142p.</p> <p>* When a recording is made with this menu switch set to "USER (MONO)", extra line data cannot be played back normally on the BR-D50/D51/D52/D350/D80/D92/D750/D860.</p>
140p	EXTRA-L R2 SEL (625)	16 18 ⋮ 33	22 319 ⋮ 334	
141p	EXTRA-L R3 SEL (625)	34 35	335 623	
142p	EXTRA-L R4 SEL (625)		[First setting] No. 139 ... 22 No. 140 ... 623 No. 141 ... 21 No. 142 ... 334	
148	IN VBLANK YCOMB (525)	0 [1] 2	OFF [ON] OFF WITH21	
148p	IN VBLANK YCOMB (625)	0 [1]	OFF [ON]	

## 5 MENU SWITCH SETTING DETAILS

### 5-2 MENU SWITCH SETTING CONTENT

[ ] : Factory setting

Menu SW No.	On-screen display	Setting		Content
		Counter display	On-screen display	
143p	EXTRA LINE PB (625)	[0] 1 2	[MUTING] AUTO USER SETTING	<p>Selects how extra line signal data is added to the playback video signal during playback.</p> <p>MUTING : Line data is not added to the playback video signal.</p> <p>AUTO : Extra line data is added to the line selected for extra line recording.</p> <p>USER SETTING : Extra line data is added to the four lines specified by the user. Lines can be selected with menu switches No. 144p to No. 147p.</p>
144p	EXTRA-L P1 SEL (625)	00 ⋮ 15	6 ⋮ 21	<p>Selects the playback video signal line to add signal data recorded on extra line 1, 2, 3 or 4 for output. Effective only when menu switch No. 143p &lt;EXTRA LINE PB&gt; is set to "USER SETTING".</p> <ul style="list-style-type: none"> <li>• No. 144P &lt;EXTRA-L P1 SEL&gt; ... Sets extra line 1.</li> <li>• No. 145P &lt;EXTRA-L P2 SEL&gt; ... Sets extra line 2.</li> <li>• No. 146P &lt;EXTRA-L P3 SEL&gt; ... Sets extra line 3.</li> <li>• No. 147P &lt;EXTRA-L P4 SEL&gt; ... Sets extra line 4.</li> </ul> <p>Select 1 line from lines 6 to 22, 319 to 335 and 623 for each extra line.</p> <p>* When the information such as time code data is superimposed on the same line, extra line data is not output.</p>
145p	EXTRA-L P2 SEL (625)	16 18 ⋮ 33	22 319 ⋮ 334	
146p	EXTRA-L P3 SEL (625)	34 35	335 623	
147p	EXTRA-L P4 SEL (625)		[First setting] No. 144 ... 22 No. 145 ... 623 No. 146 ... 21 No. 147 ... 334	
148	IN VBLANK YCOMB (525)	0 [1] 2	OFF [ON] OFF WITH21	
148p	IN VBLANK YCOMB (625)	0 [1]	OFF [ON]	

## 5 MENU SWITCH SETTING DETAILS

### 5-2 MENU SWITCH SETTING CONTENT

[ ] : Factory setting

Item		Setting		Content
Menu SW No.	On-screen display	Counter display	On-screen display	
149	VIDEO OUT SELECT	[0] 1 2	[NORMAL] SYNC DELAY A ROLL	<p>Selects the video signal output timing during editing.</p> <p><b>NORMAL</b> : Shifts the position of output video signals by 4H during editing. Normally, set to this position. *When shifting by 4H, information in the input signal's blanking sections may be input to the image area. In such a case, use "SYNC DELAY" or "A ROLL".</p> <p><b>SYNC DELAY</b> : Shifts the sync signal position during editing, without shifting the output video signals.</p> <p><b>A ROLL</b> : Shifts the output video signals by 1 frame during editing.</p>
<AUDIO>				
214	PB V. FADE	0 [1] 2	OFF [5M] 10M	<p>Selects whether or not the audio V. fade function is used for smoother edited audio transitions during playback.</p> <p><b>OFF</b> : The audio V. fade function is disabled.</p> <p><b>5M</b> : The audio V. fade function is enabled. Audio transitions are faded out and faded in for 5 msec. To reduce noise, this position is recommended.</p> <p><b>10M</b> : The audio V. fade function is enabled. Audio transitions are faded out and faded in for 10 msec.</p>
215	AUD REC VOLUME MODE 1	[0] 1	[CH1/CH2/ CH3/CH4] MAS-1 BAL-2/ MAS-3 BAL-4	<p>Selects whether the [AUDIO REC LEVEL] controls operate on individual channels or stereo pairs.</p> <p><b>CH1/CH2/CH3/CH4</b>: Each of the 4 channels can be adjusted independently with the corresponding [AUDIO REC LEVEL] volume control.</p> <p><b>MAS-1 BAL-2/MAS-3 BAL-4</b>: In this mode two stereo pairs are formed: (CH1,CH2) and (CH3,CH4). Each pair has one Master Record Level and a Channel Balance control. The controls labeled CH1 and CH3 operate as a Master Record Level for their corresponding pair. The controls labeled CH2 and CH4 operate as Balance Controls for their corresponding pair. This menu setting allows changing the recording level without changing the stereo image, or vice versa.</p>

## 5 MENU SWITCH SETTING DETAILS

### 5-2 MENU SWITCH SETTING CONTENT

[ ] : Factory setting

Item		Setting		Content
Menu SW No.	On-screen display	Counter display	On-screen display	
216	AUD PB VOLUME MODE 1	[0] 1	[CH1/CH2/ CH3/CH4] MAS-1 BAL-2/ MAS-3 BAL-4	<p>Selects the function of the [AUDIO PB LEVEL] volume controls.</p> <p><b>CH1/CH2/CH3/CH4</b>: Each of the 4 channels can be adjusted independently with the corresponding [AUDIO PB LEVEL] volume control.</p> <p><b>MAS-1 BAL-2/MAS-3 BAL-4</b>: The [AUDIO PB LEVEL] volume control for CH1 or CH3 operates as a master level control, enabling the audio playback levels of CH1 and CH2 or CH3 and CH4 to be adjusted simultaneously as a stereo pair. The [AUDIO PB LEVEL] volume control for CH2 or CH4 operates as a balance control for its corresponding pair, enabling audio playback balance to be adjusted between CH1 and CH2 or CH3 and CH4.</p>
219	SEARCH REC CH	[0] 1 2	[CH1/CH2] CH3/CH4 CH1+3/ CH2+4	<p>Selects the signal source for recording onto the linear audio tracks</p> <p><b>CH1/CH2</b> : Records CH1 audio on the linear track's L channel and CH2 audio on the linear track's R channel.</p> <p><b>CH3/CH4</b> : Records CH3 audio on the linear track's L channel and CH4 audio on the linear track's R channel.</p> <p><b>CH1+3/CH2+4</b> : Records mixed CH1 and CH3 audio on the linear track's L channel and mixed CH2 and CH4 audio on the linear track's R channel.</p>
221	SEARCH PB AT 1+3/2+4	[0] 1	[MUTING OFF] MUTING ON	<p>Selects whether or not the audio recorded on the linear track is output during search when menu switch No. 219 &lt;SEARCH REC CH&gt; is set to CH1+2/CH3+4.</p> <p><b>MUTING OFF</b> : Audio is output.</p> <p><b>MUTING ON</b> : Audio is not output.</p>
222	MONITOR MIX MODE	[0] 1 2	[AVERAGE] RMS ADDITION	<p>Selects the mixing method for the audio channels being monitored.</p> <p><b>AVERAGE</b> : Low level (arithmetical mean)</p> <p><b>RMS</b> : Medium level (geometrical mean)</p> <p><b>ADDITION</b> : High level (simple addition)</p>

## 5 MENU SWITCH SETTING DETAILS

### 5-2 MENU SWITCH SETTING CONTENT

[ ] : Factory setting

Menu SW No.	On-screen display	Setting		Content
		Counter display	On-screen display	
223	CH3/4 OUT SEL AT 2CH	[0] 1	[MUTING] CH1/CH2	When audio recorded only on CH1 and CH2 with the BR-D40, BR-D80, BR-D85 or BR-D750 is played back, select whether or not to output this audio on CH3 and CH4 as well. MUTING : Audio is not output. CH1/CH2 : Audio is output. Signals on CH1 are output to CH3 and signals on CH2 are output to CH4. The audio level meter does not move.
224	AUDIO IN LEVEL CH1	0	-6DB 0DB	Selects the analog audio reference input level. Sets each of the four channels (CH1 to CH4). -6DB : Sets the reference level to -6dB. 0DB : Sets the reference level to 0 dB. 4DB : Sets the reference level to 4 dB. -20DB : Sets the reference level to -20dB.
225	AUDIO IN LEVEL CH2	[2] 3	[4DB] -20DB	
226	AUDIO IN LEVEL CH3			
227	AUDIO IN LEVEL CH4			
228	AUDIO OUT LEVEL CH1	0 1	-6DB 0DB	Selects the analog audio reference output level. Sets each of the four channels (CH1 to CH4). -6DB : Sets the reference level to -6 dB. 0DB : Sets the reference level to 0 dB. 4DB : Sets the reference level to 4 dB.
229	AUDIO OUT LEVEL CH2	[2]	[4DB]	
230	AUDIO OUT LEVEL CH3			
231	AUDIO OUT LEVEL CH4			
232	AUDIO MON LEVEL LCH	0 1	-6DB 0DB	Selects the reference level of the audio output from the rear panel [AUDIO MONITOR] connector. -6DB : Sets the reference level to -6dB. 0DB : Sets the reference level to 0 dB. 4DB : Sets the reference level to 4 dB.
233	AUDIO MON LEVEL RCH	[2]	[4DB]	
236	PRO 48K S.R. CONV.	[0] 1	[AUTO] ON	Enables the sampling rate converter even when the input signal is a professional 48K AES/EBU signal. Always ON for digital audio signals conforming to other specifications. AUTO : The sampling rate converter is set to OFF. Use this position normally. ON : The sampling rate converter is forced ON. Set to this menu position when the incoming AES/EBU signal cannot be externally synchronized (audio signal is not in sync with video signal).

## 5 MENU SWITCH SETTING DETAILS

### 5-2 MENU SWITCH SETTING CONTENT

[ ] : Factory setting

Menu SW No.	On-screen display	Setting		Content
		Counter display	On-screen display	
237	EMBEDDED AUDIO	0 [1]	OFF [ON]	Disables the embedded audio signal from the SDI output signal Selects whether or not digital audio signals are output from the rear panel [SERIAL V/A OUT] connector together with the video signals. OFF : Digital signals are not output. ON : Digital signals are output.
247	DIG AUD AT ASYNC IN	[0] 1	[NORMAL] NOISE REDUCE	Noise will be generated in embedded audio signals if the embedded audio signals are input from a different system than the reference sync signals, or if no reference sync signals are input. This switch allows you to specify whether or not to remove this noise (effective only when the SA-D95 is installed). NORMAL : Noise is not removed. Normally set to this position. NOISE REDUCE : Processes the audio signal to reduce noise.
251	CH3/4 SOURCE SEL.	[0] 1 2 3	[CH3 ← SW/ CH4 ← SW] CH3 ← CH1/ CH4 ← SW CH3 ← SW/ CH4 ← CH2 CH3 ← CH1/ CH4 ← CH2	CH3 ← SW/CH4 ← SW: CH3 and CH4 audio input signals are determined by the front panel's audio signal select buttons. CH3 ← CH1/CH4 ← SW: CH3 audio input signals come from the same source as CH1 audio input signals. CH4 audio input signals are determined by the front panel's audio signal select buttons. CH3 ← SW/CH4 ← CH2: CH3 audio input signals are determined by the front panel's audio signal select buttons. CH4 audio input signals come from the same source as CH2 audio input signals. CH3 ← CH1/CH4 ← CH2: CH3 audio input signals come from the same source as CH1 audio input signals. The CH4 audio input signals come from the same source as CH2 audio input signals.

## 5 MENU SWITCH SETTING DETAILS

### 5-2 MENU SWITCH SETTING CONTENT

[ ] : Factory setting

Menu SW No.	Item	Setting		Content
		Counter display	On-screen display	
253	CH1 REC SIGNAL SEL	0 [1]	SILENCE [1 kHz SINE]	Selects audio signals to output from the built-in signal generator. Setting is possible for each channel. SILENCE : No signal 1 kHz SINE : Outputs audio signals with the frequency of 1 kHz.
254	CH2 REC SIGNAL SEL			
255	CH3 REC SIGNAL SEL			
256	CH4 REC SIGNAL SEL			
257	AUD REF. SIGNAL LEV.	[0] 1	[-20 dB] -18 dB	Sets the audio reference level during recording. -20 dB : Sets the audio recording reference level to -20 dB. -18 dB : Sets the audio recording reference level to -18 dB. • The audio level meter reference level indication changes according to the setting.
261	AUD SEL. AT SEARCH	[0] 1	[LINEAR AUDIO] DIGITAL AUDIO	Selects audio signals to output during search. LINEAR AUDIO : Outputs linear audio. DIGITAL AUDIO : Outputs digital audio. • Noise may be heard while the digital search sound is used. This is normal. It is not a malfunction.
<SYSTEM>				
300	DIRECT EJECT	0 [1]	OFF [ON]	Enables or disables Direct Eject. OFF : Eject is enabled only in the Stop (STANDBY ON/OFF) mode. ON : Eject is enabled in any mode.
301	DIRECT SEARCH	0 [1]	OFF [ON]	Enables/disables entering the search mode directly. OFF : The search/jog dials can be used when the [SEARCH] or [VAR] button is pressed. ON : Search and jog can be enabled in any mode except Record.
302	BACK SPACE	0 [1]	OFF [ON]	Enables or disables backspace editing using the Record, Pause and Play buttons. OFF : No backspacing after Record Pause ON : Backspacing after Record Pause. When set to OFF, recording will start more quickly than when set to ON. However, transitional picture quality is affected at the start of recording.

## 5 MENU SWITCH SETTING DETAILS

### 5-2 MENU SWITCH SETTING CONTENT

[ ] : Factory setting

Menu SW No.	Item	Setting		Content
		Counter display	On-screen display	
307	PAUSE/STILL/STP/TIME	0 1 2 3 4 5 6 [7]	1 SEC 10 SEC 30 SEC 1 MIN 2 MIN 3 MIN 4 MIN [5 MIN]	When the unit remains in the Record Pause, Still or Stop (Standby ON) mode for a long time, the Tape Protection mode is engaged automatically. This switch lets you determine how long (1 sec. to 5 min.) the unit will remain in one of these modes before the Tape Protection mode is engaged. In the Record Pause and Still modes, the tape is advanced by 1 frame when the selected duration has passed. In the Stop (Standby ON) mode, the Standby OFF mode is engaged.
311	AUTO PLAY	[0] 1	[OFF] ON	Selects the mode engaged when the tape reaches the beginning in the REW mode. OFF : Stop (STANDBY-ON) is engaged. ON : PLAY is engaged.
312	AUTO REW	[0] 1	[OFF] ON	Selects the mode engaged when the tape reaches the end in the PLAY or RECORD mode. OFF : Stop (standby-on) mode is engaged. ON : REW is engaged.
314	PB/EE MODE	[0] 1	[STOP/FF/REW] STOP	Selects the modes in which the EE mode is automatically engaged. STOP/FF/REW : Engages the EE mode in the Stop, FF and Rewind modes. STOP : Engages the EE mode in the Stop mode.
317	9PIN DEVICE ID	0 [1] 2 3	JVC D80 [JVC D860/D92/D95] DVW-A500 USER SETTING (382-385)	Selects the Device Type ID code returned by the VCR after receiving a DEVICE TYPE REQUEST via RS-422 port. JVC D80 : Replies with ID code for the BR-D750U/D350U/D80U/D50U/D85U and BR-D51U. *Set to "JVC D80" when using the RM-G820 editing remote controller. JVC D860/D92/D95: Replies with ID code for the BR-D860U/D560U/D92U/D95U. DVW-A500 : Replies with ID code for the DVW-A500. USER SETTING(382-385):Replies with ID code set with menu switches No.382 to No.385.
319	FF/REW MAX SPEED	[0] 1 2	[x60] x32 x17	Selects the maximum tape speeds in FF and REW. X60: The maximum tape speed is 60 times normal. X32: The maximum tape speed is 32 times normal. X17: The maximum tape speed is 17 times normal.

## 5 MENU SWITCH SETTING DETAILS

### 5-2 MENU SWITCH SETTING CONTENT

[ ] : Factory setting

Menu SW No.	Item		Setting		Content
	On-screen display	Counter display	On-screen display	Counter display	
320	PREROLL TIME	0 : [5] : 15	0SEC : [5SEC] : 15SEC		Sets the preroll time when the [PREROLL] button is pressed. The preroll time can be selected from 0 second to 15 seconds.
323	PREROLL END MODE	0 [1]	STANDBY-ON [STILL]		Selects which operation mode is engaged after preroll is executed. STANDBY-ON : Engages the Standby ON mode. STILL : Engages the Still mode.
328	EDIT POINT CLEAR	0 [1]	DISABLE [ENABLE]		Selects whether the edit point data is cleared after performing the edit DISABLE : The edit point is not cleared. ENABLE : The edit point is cleared.
340	SEARCH SPEED	[0] 1 3	[x 32] x 17 x 6		Selects the maximum search speed when using the search dial. X32 : Maximum search speed is +/-32 times normal. X17 : Maximum search speed is +/-17 times normal. X6 : Maximum search speed is +/-6 times normal.
351	PREREAD	[0] 1 2 3	[VID-OFF/ AUD-OFF] VID-ON/ AUD-OFF VID-OFF/ AUD-ON VID-ON/ AUD-ON		Selects whether or not the preread function is activated. Video and audio preread functions can be set independently. VID-OFF/AUD-OFF : Both video and audio preread are disabled. VID-ON/AUD-OFF : Only video preread is enabled. VID-OFF/AUD-ON : Only audio preread is enabled. VID-ON/AUD-ON : Both video and audio preread are enabled. * When using the [REC] button to start recording, be sure to set this switch to "VID-OFF/AUD-OFF".
352	AUD PREREAD TIMING	[0] 1	[NORMAL] OFF SET		Selects whether or not to apply correction during audio preread. Correction is based on output audio phase delay set with the audio control menu <AUDIO OUTPUT PHASE>. NORMAL : Does not apply correction. OFF SET : Applies correction to the output audio phase according to the delay of the connected video device.

## 5 MENU SWITCH SETTING DETAILS

### 5-2 MENU SWITCH SETTING CONTENT

[ ] : Factory setting

Menu SW No.	Item		Setting		Content
	On-screen display	Counter display	On-screen display	Counter display	
357	DIAG AT POWER ON	[0] 1	[OFF] ON		Selects whether or not self-diagnosis is executed when the power is turned on. OFF : Self-diagnosis is not executed. ON : Self-diagnosis is executed. However, if no tape is loaded when the power is turned on, self-diagnosis does not take place. While diagnostics are running ("DIAGNOSTIC" blinks on the screen), you cannot load a cassette. Do not try to forcibly load it. After completion of diagnostics, a warning indication is shown if there is an abnormality. Refer to "Warnings with Indicators" on page 145.
359	JOG FEELING (REMOTE)	[0] 1 2 3 4	[TYPE-1] TYPE-2 TYPE-3 TYPE-4 TYPE-5		Alters the operation "feel" of the connected editing controller's jog dial. Five settings (TYPE-1 (0) to TYPE-5 (4)) are available.
363	CONTROLLER SELECT	[0] 1 2 3 4 5 6 7	[DEFAULT] RM-450 NOT DEFINED NOT DEFINED NOT DEFINED NOT DEFINED NOT DEFINED		This menu changes the characteristics of the VCR to match specific types of controllers. DEFAULT : Normally set to this position. This position is ready for standard editing controllers. RM-450 : Set to this position for an editing remote controller which outputs JOG commands for synchronization. (e.g.) SONY RM-450 NOT DEFINED - TYPE-7: Not defined.
367	EDIT INTERRUPTION (525)	[0] 1	[OFF] ON		Selects whether or not editing aborts when the audio condition degrades during PREROLL. OFF : Does not stop editing. ON : Stops editing. Error message is shown on the counter display.
368	STARTING PIC FREEZE	[0] 1	[OFF] ON		Selects playback pictures or a still image as the video output until the servo locks. OFF : A playback picture is displayed. The picture may be noisy until the servo stabilizes. ON : A still image is displayed. This changes to playback video when the servo stabilizes. * When this menu switch is set to "ON" and playback starts from a still image containing the block noise, still images containing block noise are output until the servo indicator lights. To avoid this, obtain a clear still image before starting playback (using the jog dial or frame advance/reverse buttons).

## 5 MENU SWITCH SETTING DETAILS

### 5-2 MENU SWITCH SETTING CONTENT

[ ] : Factory setting

Menu SW No.	Item	Setting		Content
		Counter display	On-screen display	
369	PARA-RUN	[0] 1	[OFF] ON	Allows daisy chaining of several VCR's via the [REMOTE IN (9P)] and [REMOTE OUT (9P)] connectors, enabling you to control all connected VCRs at the simultaneously. OFF : Set to this position to control the VCR independently. ON : Set to this position for a simultaneous operation. Apply this menu setting to all connected VCR's.
371	INPUT SELECT SAFETY	[0] 1	[OFF] ON	Switches ON a safety function to prevent accidental change of input router OFF : Deactivates this function. Signal is switched when an input switch is pressed. ON : Activates this function. To change the input signal selection, press the input switch while pressing the [SHIFT] button.
372	P+R AT SWAP MODE	[0] 1	[ENABLE] DISABLE	Selects whether or not simultaneous operation of the player and recorder is permitted by pressing the [PLAYER] and [RECORDER] buttons together during swap editing. ENABLE : Simultaneous operation for the player and recorder is possible. DISABLE : Simultaneous operation is not possible. Before operation, select the VCR with the [PLAYER] or [RECORDER] button.
373	MATCH FRAME	[0] 1	[OFF] ON	This setting determines whether or not the automatic match frame function is used. OFF : Match-frame is disabled. ON : Match-frame is enabled. After an edit has been executed, the edit-out points of both the player and recorder are automatically registered as edit-in points for the next edit.
374	MENU OPEN SAFETY	[0] 1	[OFF] ON	Selects the method for opening the menu. OFF : Pressing the [MENU] button engages the menu switch setting mode. ON : Pressing the [MENU] + [SHIFT] buttons simultaneously engages the menu setting mode.

## 5 MENU SWITCH SETTING DETAILS

### 5-2 MENU SWITCH SETTING CONTENT

<TIME CODE> [ ] : Factory setting

Menu SW No.	Item	Setting		Content
		Counter display	On-screen display	
375	AUD EDIT PRESET CH1	0 [1] 2 3	NO DEFINITION [CH1] CH2 CH1 OR CH2	This mode allows edit controllers that have only two audio channel capabilities to edit all four audio channels. The audio insert edit command is translated using the definition set by this menu to perform CH1 through CH4 edits. NO DEFINITION: Accepts no command. CH1 : Executes insert edit of the channel selected when the CH1 insert command appears. CH2 : Executes insert edit of the channel selected when the CH2 insert command appears. CH1 OR CH2 : Executes insert edit of the channel selected when the CH1 or CH2 insert command appears.
376	AUD EDIT PRESET CH2	0 1 [2] 3	NO DEFINITION CH1 [CH2] CH1 OR CH2	
377	AUD EDIT PRESET CH3	[0] 1	[NO DEFINITION]	
378	AUD EDIT PRESET CH4	2 3	CH1 CH2 CH1 OR CH2	
381	JOG FEELING (LOCAL)	[0] 1	[NORMAL] INSENSITIVE	Selects jog dial operation response level. NORMAL : Normally set to this position. INSENSITIVE : Slower than NORMAL mode.
382	9 PIN ID---(1ST)	0 : [15]	0 : [F]	Sets the ID reply code when menu switch No.317 <9 PIN DEVICE ID> is set to "3: USER SETTING (382-385)". Specify a hexadecimal 4-digit ID code with these four menu switches (set each digit with each corresponding menu switch). Select hexadecimal digits (0 to F).
383	9 PIN ID-■-(2ND)	0 [1] : 15	0 [1] : F	
384	9 PIN ID--■-(3RD)	0 [1] : 15	0 [1] : F	
385	9 PIN ID---■(4TH)	0 : [15]	0 : [F]	
386	MUTING AT NO TAPE	[0] 1	[DISABLE] ENABLE	Even when the PB mode is selected with the [PB PB/EE] button, the EE mode is engaged when no tape is loaded. In this case, this switch is used to select whether the audio and video signals are output or not. DISABLE : The audio and video signals are output. ENABLE : The audio and video signals are not output.

## 5 MENU SWITCH SETTING DETAILS

### 5-2 MENU SWITCH SETTING CONTENT

[ ] : Factory setting

Menu SW No.	Item		Setting		Content
	On-screen display	Counter display	On-screen display	Counter display	
387	CF FLAG REPLY (525)	[1] 2 3	[4 FLD] 2 FLD OR 4 FLD OFF		When color framing lock is applied, the STATUS DATA CF lock bit transmitted from the 9-pin remote connector is set to ON. This switch selects the field unit where the CF lock bit is set to ON.
387p	CF FLAG REPLY (625)	[0] 1 2 3	[8 FLD] 4 FLD OR 8 FLD 2 FLD OR 4 FLD OR 8 FLD OFF		<ul style="list-style-type: none"> <li>•NTSC           <ul style="list-style-type: none"> <li>4FLD : The bit is set to ON with 4-field unit.</li> <li>2FLD OR 4FLD : The bit is set to ON with 2 or 4-field unit.</li> <li>OFF : The bit is set to OFF at all times.</li> </ul> </li> <li>•PAL           <ul style="list-style-type: none"> <li>8FLD : The bit is set to ON with 8-field unit.</li> <li>4FLD OR 8FLD : The bit is set to ON with 4 or 8-field unit.</li> <li>2FLD OR 4FLD OR 8FLD : The bit is set to ON with 2, 4 or 8-field unit.</li> <li>OFF : The bit is set to OFF at all times.</li> </ul> </li> </ul>
389	MULTI CUE MODE	[0] 1	[OFF] ON		Selects whether or not the multi cue-up function is used. OFF : Multi cue-up function is disabled. The normal mode is engaged. ON : The Multi Cue mode is engaged. For more information about the multi cue-up function, see page 92.
390	SWAP VTR SELECT	[0] 1 ∴ 9	[AUTO] TYPE 1 ∴ TYPE 9		Sets according to the player VCR during swap editing. Normally set to "AUTO". AUTO : Set to this position when a BR-D95U, BR-D92, BR-D52 or DVW-A500 is connected. TYPE 1 to TYPE 9 : Not used.
391	SYNCHRONIZATION	0 [1]	DISABLE [ENABLE]		Selects whether or not the BR-D95U's built-in editor issues capstan bump commands for frame accurate swap editing. DISABLE : The bump function does not operate. ENABLE : The bump function operates. (Set the preroll time to 5 seconds or more).
393	SYNC GRADE	[0] 1 2 3	[ACCURATE] +/-1 FRAME +/-2 FRAME ROUGH		Selects the editing accuracy during swap editing. ACCURATE : 0 frame +/-1FRAME : +1 frame +/-2FRAME : +2 frames ROUGH : Rough
395	AUTO-EE	[0] 1	[RECORDER ONLY] AUTO-EE		Selects whether the BR-D95U automatically switches from Playback to EE for single monitor operation during swap editing. RECORDER ONLY : Disables the auto EE function. AUTO-EE : Enables the auto EE function. When the player is selected, this unit enters the EE mode and the player's output signals are automatically passed through and displayed (this function is useful for editing with only one monitor).

## 5 MENU SWITCH SETTING DETAILS

### 5-2 MENU SWITCH SETTING CONTENT

[ ] : Factory setting

Menu SW No.	Item		Setting		Content
	On-screen display	Counter display	On-screen display	Counter display	
400	VITC LINE-1 SEL (525)	0 ∴ 5 [6] ∴ 10	10 ∴ 15 [16] ∴ 20		Selects a line in the vertical interval from line 10-20 for VITC time code insertion. Sets the location for the first VITC line, which will be inserted in the vertical interval.
400p	VITC LINE-1 SEL (625)	0 ∴ 11 [12] 13 14 15	7 ∴ 18 [19] 20 21 22		Selects a line in the vertical interval from lines 7 to 22 for VITC time code insertion. Sets the location for the first VITC line, which will be inserted in the vertical interval.
401	VITC LINE-2 SEL (525)	0 ∴ 7 [8] 9 10	10 ∴ 17 [18] 19 20		Selects a line in the vertical interval from line 10-22 for VITC time code insertion. Sets the location for the second VITC line, which will be inserted in the vertical interval.
401p	VITC LINE-2 SEL (625)	0 ∴ 13 [14] 15	7 ∴ 20 [21] 22		Selects a line in the vertical interval from lines 7 to 22 for VITC time code insertion. Sets the location for the second VITC line, which will be inserted in the vertical interval.
402	CTL DF SELECT (525)	[0] 1 2	[TCG SETTING] NON DROP DROP		<p>Selects the CTL counter to operate in the NONDROP or the DROP frame mode.</p> <p>TCG SETTING: Non-drop Frame mode is engaged when the [DF/NDF] switch on the sub panel is set to NDF. If it is set to "DF", the Drop Frame mode is engaged.</p> <p>NON DROP : Non-drop Frame mode is engaged.</p> <p>DROP : Drop Frame mode is engaged.</p>
403	REGEN MODE	[0] 1 2	[TC&UB] TC UB		Selects what elements of time the code (TC, UB) are regenerated. Selects TC or UB in the Time Code Regeneration mode. TC&UB : Regenerates time code and user bits. TC : Regenerates time code only. Preset UB data are recorded onto the user bits. UB : Regenerates user bits only. Preset TC data are recorded onto the time code.

## 5 MENU SWITCH SETTING DETAILS

### 5-2 MENU SWITCH SETTING CONTENT

[ ] : Factory setting

Item		Setting		Content
Menu SW No.	On-screen display	Counter display	On-screen display	
409	EXT REGEN TC	[0] 1	[LTC] VITC	Selects LTC or VITC as the time code source for locking the BR-D95's built-in TC Generator to an external master TC generator. LTC : The TC generator locks to the LTC data from the rear panel connector labeled TC IN. VITC : The TC generator locks to the VITC data from the rear panel connector labeled VIDEO IN.
410	AUTO REGEN MODE	[0] 1 2 3	[ASM+INS] ASM INS OFF	Selects the edit mode in which time code is regenerated (even if the [PRESET/REGEN] switch is set to "PRESET"). ASM+INS : Regenerates in the Assemble and Insert modes. ASM : Regenerates in the Assemble mode. INS : Regenerates in the Insert mode. OFF : The setting of the [PRESET/REGEN] switch is used.
421	TCG CF FLAG	[0] 1 2	[OFF] ON AUTO	Selects whether the color frame flag is set to ON or OFF for a vacant bit in the time code. OFF : Sets the color frame flag to OFF. ON : Sets the color frame flag to ON. AUTO : Sets the color frame flag to ON or OFF according to the relationship between the video signals being recorded and the color framing of the time code. (See page 106)
450	SUB TC(VITC) REC  * If this menu switch is set to "OFF" and menu switch No. 451 <VITC OUT SELECT> is set to "OFF" or "TC", the on-screen sub time code indication will not advance in the Play mode. This is the case even when playing back a tape with sub time code recorded.	0 [1]	OFF [ON]	Selects incoming VITC or memory preset as the source of the data recorded onto the Sub-Time Code OFF : "00.00.00.00" is always recorded on the sub time code. ON : Input VITC is recorded in sub time code.
451	VITC OUT SELECT	0 [1] 2	SUB TC [TC] OFF	Selects the source for the VITC TC superimposed on video output signal. SUB TC : Sub time code is delivered to the output VITC. TC : Main time code is delivered to the output VITC. OFF : VITC is not output.
452	SEARCH LTC	0 [1]	OFF [ON]	Enables or disables LTC output in the shuttle Search mode. LTC is output from the [TC OUT] connector. OFF : LTC is output only in X1 tape speed. *LTC is not output in the Program Playback mode. ON : LTC is output in all search speed modes. (Continuous time code is not available).

## 5 MENU SWITCH SETTING DETAILS

### 5-2 MENU SWITCH SETTING CONTENT

[ ] : Factory setting

Item		Setting		Content
Menu SW No.	On-screen display	Counter display	On-screen display	
457	UB PRESET AUTO	[0] 1	[OFF] ON	When user bit data is TC-preset, the data is stored in memory. Selects whether or not the user bit data is automatically preset based on the stored user bit data when the power is turned on. OFF : The UB auto preset function is disabled. ON : The UB auto preset function is enabled. *When this is set to ON, user bit data from the 9-pin remote controller cannot be preset.
<ON-SCREEN>				
501	CHARA H POSITION	[0] 6	With these menu switches, the menu switch setting screen changes to the normal on-screen data display.	Selects the On-Screen data display's horizontal position from 7 possible locations. The factory default position [0] is at the extreme right of the monitor display. The position shifts leftward as the numbers increase.
502	CHARA V POSITION	[0] 11	The actual position of the on-screen data display is moved.	Selects the On-Screen data display's vertical position from 12 possible locations. The factory-set 0 position is at the bottom of the monitor display. The position shifts upward as the numbers increase. When menu switch No. 504 <INFORMATION SELECT> is set to "TIME+MODE" or "TIME+SUB TC", the position set with 10 is the same as that with 11. When menu switch No. 504 is set to "TIME+SUB TC+MODE", the position set with 9 or 10 is the same as 11.
504	INFORMATION SELECT	0 [1] 3 4	TIME [TIME+MODE] TIME+SUB TC TIME+SUB TC+MODE	Selects on-screen display data. TIME : Displays time data only. TIME+MODE : Displays time data and mode data. TIME+SUB TC : Displays time data and sub time data. TIME+SUB TC+MODE: Displays time data, sub time data and mode data.  * A slight delay occurs in the displayed time code data. Do not dub the on-screen data as it is to a tape for off-line editing.
505	REMAIN ENABLE	[0] 1	[DISABLE] ENABLE	Selects whether of not the tape remaining information is displayed on screen. DISABLE : Not displayed. ENABLE : Displayed. For display contents, refer to page 23.



## 5 MENU SWITCH SETTING DETAILS

### 5-2 MENU SWITCH SETTING CONTENT

[ ] : Factory setting

Item		Setting		Content
Menu SW No.	On-screen display	Counter display	On-screen display	
512	MUTING/ALARM MESSAGE	[0] 1	[OFF] ON	Selects whether "MUTING" or "CONDITION ALARM" messages appear On-Screen. This menu makes it easier to check the VCR's operation status. The on-screen display is shown on the monitor connected to the [VIDEO MONITOR OUT] connector. OFF : The "MUTING" and "CONDITION ALARM" are not displayed. ON : The "MUTING" and "CONDITION ALARM" are displayed. For more details, refer to the "MUTING/ CONDITION ALARM" display on page 24.
513	EDIT ON SCREEN	0 [1]	OFF [ON]	Selects whether the edit on-screen display is ON or OFF during editing. On-screen information is output from the [LINE2 SUPER OUT] connector. OFF : Does not show the edit on-screen display during editing. ON : Show the edit on-screen display during editing.
<TBC. FRAME MEMORY>				
601	V.BLANK MASK	0 [1] 2	OFF [ON] ON WITH 0.5H	Enables/disables masking of the vertical interval. OFF : No masking. ON : Masks the vertical interval. ON WITH 0.5H : Masks section for 0.5H in addition to the vertical interval (analog signals only). * When this menu is set to "OFF", only the recordable sections of the signals output for V. blanking in the EE mode are output (VITC, EXTRA LINE, EXTENSION LINE). When this menu is set to "ON", VITC and EXTRA LINE have priority in each menu setting (refer to page 89).
620	DUBBING LOOP	[0] 1 2 3	[OFF] 3 TIMES 5 TIMES 10 TIMES	Selects whether or not the multi-generation test "Dubbing Loop Function" is used to aid adjusting an analog component system to unity gain. When this mode is active, the VCR automatically switches to its internal color bar generator and continuously builds the number of generations selected. OFF : The dubbing loop function is disabled. 3 TIMES : The dubbing loop function repeatedly builds 3 generations every few seconds. 5 TIMES : The dubbing loop function repeatedly builds 5 generations every few seconds. 10 TIMES : The dubbing loop function repeatedly builds 10 generations every few seconds. * When set to any setting except OFF (0), this unit enters the Dubbing Loop mode. * For more details on the dubbing loop function, refer to page 122.

## 6 PREPARATION

### 6-1 OPERATION MODE LOCK

This unit is provided with an operation mode lock facility. This function prevents accidental changes to switch and control settings. When this function is ON, currently selected modes and knob or switch positions cannot be adjusted.

- Use menu switch No. 002 <OPERATION LOCK> to enable this function.
- With this function enabled, operation of all front panel control buttons, adjustment knobs, dials and switches is disabled and changes to menu switch settings are not possible. When this function is activated, it is not possible to change menu switch settings. However, the [PHONES LEVEL] control and menu switch No. 002 <OPERATION LOCK> (to release the operation mode lock function) can be used.

#### Procedure

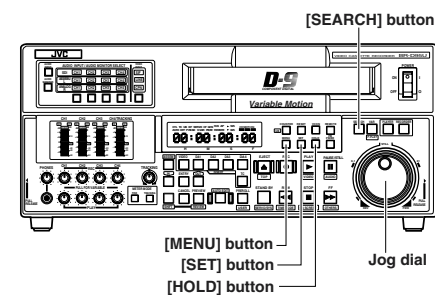

1. Make all desired settings and operate as usual.

2. Engage the operation lock function.

- ① Press the [MENU] button to call up the menu setting display.
- ② Turn the jog dial and select menu switch No. 002 <OPERATION LOCK>.

If the Direct Access facility is ON, press the [STAND BY] button to call up the menu item display more quickly.

- ③ Select "ON (1)" by turning the jog dial while pressing the [SEARCH] button.
- ④ Press the [SET] button.  
The operation lock function is ON.  
After the SET indication blinks for several seconds, the normal counter and on-screen displays are restored.

3. To cancel the operation mode lock facility, set menu switch No. 002 <OPERATION LOCK> to "OFF (0)".

## 6 PREPARATION

### 6-2 STANDBY ON/OFF

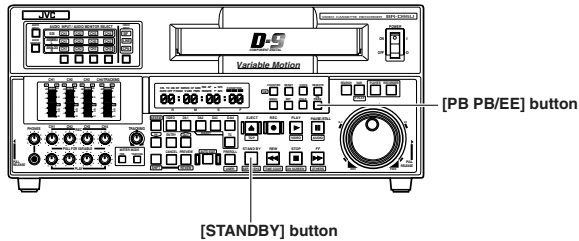

#### Notes

- Output mode selection in the Standby ON/OFF mode

Pressing the [PB PB/EE] button switches between Still output or the EE mode. The counter display changes to "PB" or "PB/EE".

In the EE mode, the input signal can be monitored.

- When video and audio signals are output from the built-in signal generator;

To output video signals from the signal generator, press the [VIDEO INPUT] button so that all [VIDEO INPUT] indicators light.

Select the video signal type from the signal generator with menu switch No. 111 <VD REC SIGNAL SEL.>.

To output audio signals (1 kHz, sine wave) from the signal generator, set menu switches No. 253 to No. 256 <CH1 to 4 REC SIGNAL SEL.> to "1 kHz SINE" and press the audio signal select buttons to select the required channels. The corresponding [AUDIO INPUT] indicators will light.

- In the PB mode, pressing the [REC] button allows you to monitor the input signal. Pressing the [STOP] button restores the Play mode.

Two different sub modes are available in the Stop mode.

**Standby ON mode:** The tape is loaded and the head drums are rotating, permitting quick start of operation when another mode is engaged. The [STANDBY] button is illuminated.

**Standby OFF mode:** The tape is loaded but the drums are stationary. The tape and the heads are protected against damage in this mode. The [STANDBY] button's light goes out.

The Output mode in the Standby ON and OFF modes can be selected with the [PB/EE] button (see notes for details).

#### Procedure

- Standby ON mode is engaged when the cassette is loaded or when the Stop mode is engaged with the STOP button.
- To change the Standby ON mode to the Standby OFF mode, press the [STANDBY] button.
  - The [STANDBY] button goes out, indicating that the Standby OFF mode has been engaged.
- To change the Standby OFF mode to Standby ON mode, press the [STANDBY] button.
  - The [STANDBY] button is illuminated, indicating that the Standby ON mode has been engaged.

\* The Standby ON mode is automatically switched to the Standby OFF mode after about 5 minutes to protect the tape and the heads. The time when the Standby OFF mode is engaged can be selected with menu switch No. 307 <PAUSE/STILL/STP TIME>.

## 6 PREPARATION

### 6-3 LOADING AND UNLOADING THE CASSETTE

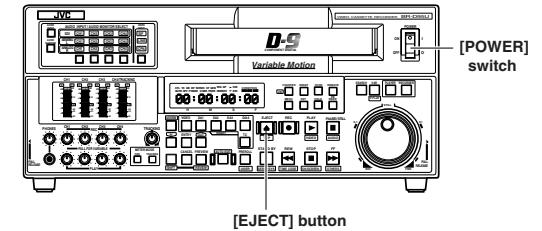

#### Notes

- To call up the on-screen display, set the [ON SCREEN] switch on the sub panel to "ON". On-screen data are output through the rear panel [LINE2-SUPER] connector.

- Be sure to use only **Hi-Fi** cassette tapes. VHS/S-VHS cassettes cannot be used.

- Conditional EJECT operation  
When menu switch No. 301 <DIRECT EJECT> is set to "OFF (0)", the [EJECT] button is enabled only in the Standby ON or OFF mode.  
With this switch set to "ON (1)", tapes can be ejected in any mode.

#### Loading the cassette

##### 1. Turn the [POWER] switch on.

→ The counter display is illuminated.

\* If a cassette is not loaded, the counter display indicates "No Tape" and the on-screen display indicates "NO TAPE". These are not shown when setting the menu switches.

##### 2. Load the cassette.

If tape tension is slack, tighten it before inserting the cassette. Insert the cassette with the cassette label facing you. Press the center of the cassette gently until the loading mechanism takes over.

→ The cassette is automatically drawn into the slot and the [STOP] button lights.

When the cassette is fully loaded, the Standby ON mode is engaged and the [STANDBY] button lights.

\*When a cassette tape with the REC switch set to OFF is loaded, "REC Inh" is shown on the tape counter display for about 2 seconds.

#### Unloading the cassette

##### 1. Press the [EJECT] button.

→ The cassette is ejected.  
The CTL counter is reset.

##### 2. Remove the cassette from the slot.

#### Precautions

- Do not insert anything other than a cassette into the slot.
- Do not try to remove the cassette once automatic cassette loading has begun. Wait until loading is complete, then press the [EJECT] button.

# 7 RECORDING

## 7-1 PREPARATION FOR RECORDING

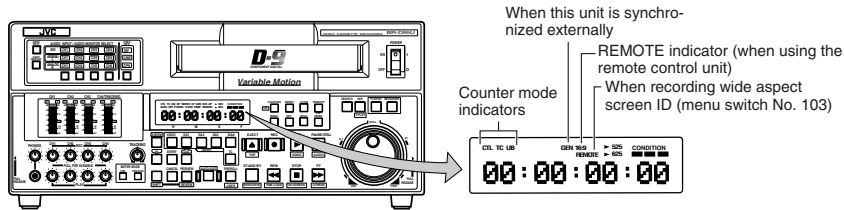

### Front panel switch setting

- Select the input video signal.**
- Select the input audio signal.**
- Select the audio monitor output.**  
Select the audio monitor output from the rear panel [AUDIO MONITOR OUT] connectors or the front panel [PHONES] jack.  
For details of steps 1 to 3, refer to page 70.
- Set the tape counter mode.**  
Set the time data to be shown on the counter display and on-screen display. "CTL", "TC" or "UB" will be shown on the counter display.
- Engage the Remote mode.**  
To operate this unit locally, press the [REMOTE] button so that the "REMOTE" indicator on the counter display goes out.

### Menu switch setting

Set the menu switches as required.

- Video items**  
Reference sync signal items  
• Select the reference sync system.  
No. 003 <SYNC SELECT> ..... Page 43  
Set to "EXT" to synchronize with an external sync signal.
- Video items**  
• Wide aspect ID signal selection  
No. 103 <WIDE ASPECT ID REC> ... Page 44  
• Component video input level selection (NTSC only)  
No. 104 <COMPONENT LEVEL> ... Page 44  
• Recording a signal from the built-in signal generator  
No. 111 <VD REC SIGNAL SEL.> ... Page 44  
Select a color bar signal, black picture, multi burst or pulse & bar.

### Audio items

- Audio recording level adjustment mode selection  
No. 215 <AUD REC VOLUME MODE 1>  
For details, refer to page 50.
- Search audio recording selection  
No. 219 <SEARCH REC CH> ..... Page 51  
Select the type of audio to be recorded on the cue track (2 tracks).
- Audio monitor output mode selection  
No. 222 <MONITOR MIX MODE> ..... Page 51  
Select the way mixed audio is output from the [AUDIO MONITOR OUT] connectors or [PHONES] jack.
- Input audio level selection (by channel from 1 to 4)  
No. 224 to No. 227 <AUDIO INPUT LEVEL CH 1-4> ... Page 52  
Select the audio input level of the rear panel [AUDIO IN] connectors from "+4 dB", "0 dB", "-6 dB" and "-20 dB" for each channel.

### Record pause selection

- Backspacing selection  
No. 302 <BACKSPACE> .... Page 54
- **Set the relationship between the serial digital video signal input and AES/EBU input (Only when the optional SA-D95U digital interface board is installed)**  
• To input asynchronous professional 48 kHz AES/EBU signal  
No. 236 <PRO 48K S.R.CONV.> ... Page 52  
Set to "AUTO" to input a serial digital audio signal with professional 48 kHz sampling frequency from a source unit which cannot be genlocked.

For time code and editing settings, refer to "10. HOW TO USE THE TIME CODE" and "11. EDITING".

\* This unit cannot be used for sound-on-sound editing. Inserted audio signals are delayed.

# 7 RECORDING

## 7-2 INPUT VIDEO AND AUDIO SIGNAL SELECTION

The video and audio input signal select method is different depending on the setting of menu switch No. 371 <INPUT SELECT SAFETY>. The procedure when menu switch No. 371 <INPUT SELECT SAFETY> is set to "OFF" is described below.

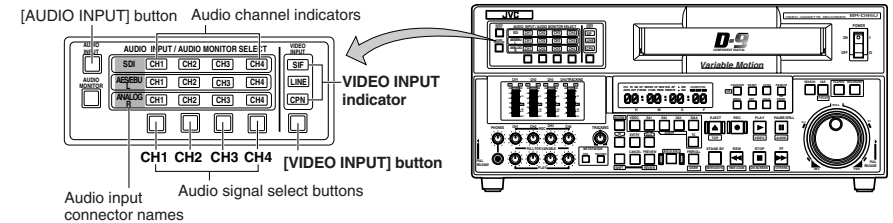

### Changing the video and audio input signal select method

- Set menu switch No. 371 <INPUT SELECT SAFETY> to "ON (1)" to prevent the setting from being changed accidentally.
- When set to "ON (1)", the input signal select methods are as follows.
- Video signal: Press the [VIDEO INPUT] button while pressing the [SHIFT] button.
  - Audio signal: Press the audio signal select button while pressing the [SHIFT] button.

- When the [AUDIO MONITOR] button is illuminated, the audio channel indicator can be used to select the audio monitor signal. The orange "L" and "R" indicators show the audio monitor output connectors.
- The input source for CH3 and CH4 audio signals can be selected with menu switch No. 251 <CH3/4 SOURCE SEL.>.
- When the SDI, AES/EBU, and ANALOG indicators are lit, audio signals from the built-in signal generator are recorded. Select audio signals from the built-in signal generator with menu switches No. 253 to 256 <CH1 to 4 REC SIGNAL SEL.>.

- The channel indicator blinks if the selected signal does not conform to the standard.

### Input video signal selection

Select the signal from rear panel video input connector or built-in signal generator.

- Press the [VIDEO INPUT] button to select the video signal.**  
The [VIDEO INPUT] indicator corresponding to the pressed button lights.  
SIF : Input a serial digital video signal to the rear panel [SERIAL V/A IN] connector (effective only when the optional SA-D95U digital interface board is installed).  
LINE : Input composite video signals to the rear panel [COMPOSITE LINE IN] connector.  
CPN : Input component video signals to the rear panel [COMPONENT IN] connector.  
SIF, LINE, CPN lit simultaneously: Records a color bar, black picture, multi burst or pulse & bar from the built-in signal generator (select with menu switch No. 111 <VD REC SIGNAL SEL.>).  
Blinking : The indicator blinks if no signal is input or if the wrong type of signal is input.  
■ When composite monochrome signals are input, use the COMPONENT Y input, not the LINE input. This will minimize degradation during signal processing. In this case, set menu switch No. 104 <CPN LEV./SETUP> to "HIGH/ON" or "HIGH/OFF" in the [525] mode.

### Input audio signal selection

This unit is provided with independent four-channel input connectors for analog audio, serial digital audio (AES/EBU), and SDI audio. Select the audio signal to be recorded on each of the four audio channels (1 to 4).

- Press the [AUDIO INPUT] button so that the [AUDIO INPUT] button is illuminated.**  
• When the [AUDIO INPUT] button is illuminated, the audio channel indicator can be used to select input audio signal.
- Select the audio signal to be recorded on each of four audio channels (1 to 4) by pressing the audio signal select button.**  
The channel indicator of the selected audio signal lights.

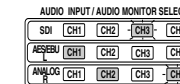

### Notes:

- Audio can only be input to the [AES/EBU] or [SERIAL V/A] connectors when the optional SA-D95U digital interface board is installed.
- Always input external sync signals when inputting digital signals. Both video and audio must be synchronized with the external sync signal.

(Illustrated example)

- The first audio channel on the tape: Audio to the [AES/EBU CH1] connectors is recorded.
- The second audio channel on the tape: Audio to the [AUDIO IN CH2] connectors is recorded.
- The third audio channel on the tape: Audio to the [SERIAL V/A IN] connectors is recorded.
- The fourth audio channel on the tape: Audio to the [AUDIO IN CH4] connectors is recorded.

7-3 AUDIO MONITOR OUTPUT SIGNAL SELECTION

Select the audio to be output to the headphones jack or the rear panel [AUDIO MONITOR L/R] connectors. Select a single channel or mixed audio from the four available channels. During playback, select the playback audio monitor output signal.

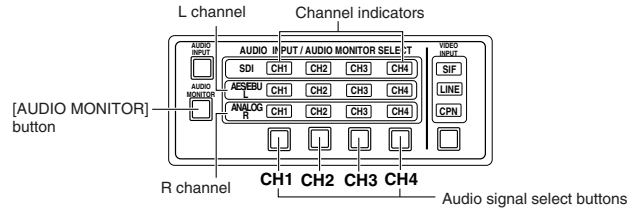

1. Press the [AUDIO MONITOR] button so that the [AUDIO MONITOR] button is illuminated.



When the [AUDIO MONITOR] button is illuminated, the audio channel indicator can be used for the audio monitor output signal.

2. Select the audio monitor output signal by pressing the audio signal select button.

Select the audio signal from CH 1 to CH 4 to be output to the L and R channels of the [AUDIO MONITOR] connectors and the headphones jack. The selected channel indicator lights.

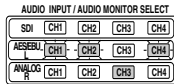

(Illustrated example)

- L channel of the [AUDIO MONITOR] connectors and headphones: Output mixed audio of the first, second and fourth channels.
- R channel of the [AUDIO MONITOR] connectors and headphones: Output the audio from the third channel.

- When the [AUDIO INPUT] button is illuminated, the channel indicator can be used to select the input audio signal.

- Select the output level mode for audio monitor mixing output with menu switch No. 222 <MONITOR MIX MODE>.
- Setting the audio monitor output level  
Set the audio monitor L and R channel output levels to +4 dB, 0 dB or +6 dB with menu switches No. 232 and No. 233.

7-4 AUDIO RECORD LEVEL ADJUSTMENT

- Audio signal recording level can be adjusted.

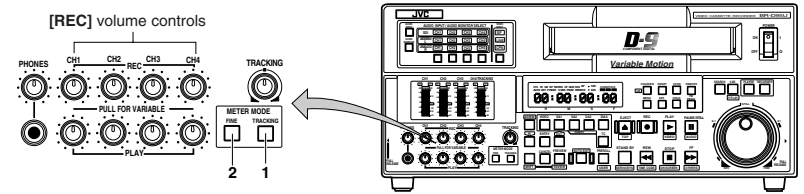

- Recording level adjustment in the Standby mode is possible in the EE mode.

- During recording or audio level adjustment, audio can be monitored via the rear panel [AUDIO MONITOR] connectors or the front panel [PHONES] jack. For monitor output, refer to page 70.

- When menu switch No. 215 [AUD REC VOLUME MODE1] is set to "MAS-1 BAL-2/MAS-3 BAL-4", the master level adjust and balance adjust functions assigned to each volume control are enabled even if the corresponding channel is in the Unity mode.

- The audio reference level can be set with menu switch No. 257 <AUD REF. SIGNAL LEV.> (-20 dB or -18 dB).

- The recording level of this unit can be adjusted either fixedly or manually. To adjust the recording level, pull out the [REC] volume controls to engage the Manual mode and push in them to engage the Fixed (Unity) mode. Either mode can be selected independently for each audio channel.

Fixed recording level adjustment

Push in the [REC] volume controls to engage the Unity mode for recording level adjustment.

- In the Unity mode, the [R] indicator on the upper section of the meter lights. This means that adjustment is not possible with the [REC] volume controls.

Manual recording level adjustment

- Pull out the [REC] volume controls to engage the Manual mode for recording level adjustment. In the Manual mode, the [R] indicator on the upper section of the meter goes out.

There are two ways to adjust recording levels manually.

- ① Adjust the audio level for each channel independently with the CH1 to CH4 [REC] volume controls.
- ② Use CH1 and CH2 [REC] volume controls as one pair and CH3 and CH4 [REC] volume controls as one pair. Adjust the audio level with the CH1 and CH3 [REC] volume controls as a master volume control and the CH2 and CH4 [REC] volume controls as a balance control.

Select the adjustment mode with menu switch No. 215 <AUD REC VOLUME MODE 1>.

Menu switch setting

- Select the manual recording level adjustment mode with menu switch No. 215 <AUD REC VOLUME MODE 1>.
- "CH1/CH2/CH3/CH4 (0)": To independently adjust the recording level for each channel with CH1 to CH4 [REC] volume controls.
- "MAS-1 BAL-2/MAS-3 BAL-4 (1)": Use CH1 and CH3 [REC] volume controls for master volume control and the CH2 and CH4 [REC] volume controls for balance control.

## 7 RECORDING

### 7-4 AUDIO RECORD LEVEL ADJUSTMENT

- The audio level meter's reference level indication changes depending on the setting of menu switch No. 257 <AUD REF. SIGNAL LEV.> (-20 dB or -18 dB).

#### 1. Set the [CH4/TRACKING] meter to audio level.

- When the [METER MODE TRACKING] button is illuminated, press the [METER MODE TRACKING] button.

→ The [METER MODE TRACKING] button goes out and the [CH4/TRACKING] meter can be used for the CH4 audio level.

#### 2. Adjust the recording level for each channel (CH1 to CH4) separately with the [REC] volume control.

- To perform fine adjustment, press the [METER MODE FINE] button.
- The [METER MODE FINE] button is illuminated and the audio level meter shows the fine level around -20 dBFS or -18 dBFS.



Normal mode level indication

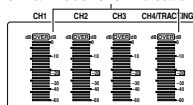

Fine mode level indication

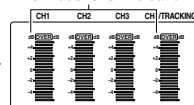

- The reference input level shown by the audio level meter is -20 dBFS or -18 dBFS.

#### Adjust with the master and balance controls

The CH1 and CH2 [REC] volume controls, and the CH3 and CH4 [REC] volume controls work as one set.

The CH1 and CH3 [REC] volume controls serve as master volume control and the CH2 and CH4 volume controls as balance control.

- Turn the CH1 or CH3 [REC] volume control. The audio on CH2 or CH4 changes along with CH1 or CH3.
- Turn the CH2 or CH4 [REC] volume control to adjust the balance between CH1 and CH2 or CH3 and CH4.

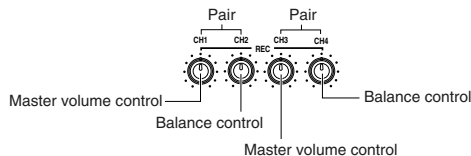

## 7 RECORDING

### 7-5 BASIC RECORDING OPERATIONS

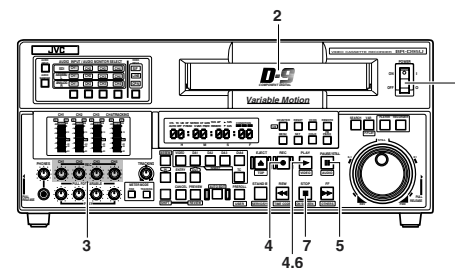

#### Notes

- Be sure to use only **DIGITAL S** cassette tapes. VHS/S-VHS cassettes cannot be used.
- Recording the video signal by the internal signal generator. Select the color bar signal, black picture multi burst or pulse & bar signal with menu switch No. 111 <VD. REC SIGNAL SEL.> and press the [VIDEO INPUT] button so that all [VIDEO INPUT] indicators light.
- Refer to "10 HOW TO USE THE TIME CODE" for time code recording.

#### 1. Turn the [POWER] switch "ON".

#### 2. Load the cassette.

Make sure that the protective slide on the cassette is set to "REC".  
→ The tape is loaded and the "STANDBY" button lights.

#### 3. Adjust the audio signal recording level.

(See page 69 for audio recording level adjustment.)

#### 4. Start recording.

Press the [PLAY] buttons while pressing the [REC] button.  
→ The [REC] and [PLAY] buttons light and recording starts.

#### 5. To temporarily stop recording

Press the [PAUSE/STILL] button.  
→ The [PAUSE/STILL] button lights and recording is paused.

#### 6. To re-start recording

Press the [PLAY] button.  
→ The [PAUSE/STILL] button goes out and recording starts again.

#### 7. To end recording

Press the [STOP] button.  
→ The [REC] and [PLAY] buttons indicators go out and the tape stops.

The Standby ON mode is automatically engaged when the tape ends.

- When menu switch No. 312 <AUTO REW> is "ON (1)", the tape is automatically rewound to the beginning.

- When the Play mode is switched to the E-E mode, the picture slightly shifts downward for a moment. However, the recording is not affected.

\* Even if the frame is advanced periodically in the Record-Pause mode (every 5 minutes or so), the mode will still disengage after about 20 minutes to protect the heads and the VCR will automatically enter the Standby Off mode. You can specify the length of time that elapses before the frame is advanced in the Record-Pause mode with menu switch No. 307 <PAUSE/STILL/STP TIME>.

If menu switch No. 351 <PRE READ> is set to "ON", the Record mode cannot be engaged. For recording, set it to "OFF".

## 7-6 DIGITAL AUDIO SIGNAL INPUT/OUTPUT

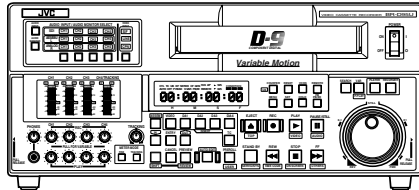

- This unit does not execute emphasis recording. When digital audio signals containing emphasis information are input to this unit, this unit automatically de-emphasizes these signals before recording. The emphasis function is always OFF when digital audio signals are recorded on this unit.

**Note:**

- Analog or digital audio output may not be clear when a tape whose audio has been recorded on its audio channels with emphasis both ON and OFF is played back on the BR-D85U/D80U/D51U/D50U/D750U/D350U DIGITAL S VCR.

- A sampling rate converter is provided for the BR-D95U's AES/EBU input. This enables input of both professional-standard and consumer-standard digital signals with sampling frequencies of 48 kHz, 44.1 kHz and 32 kHz. However, the following signals are muted and cannot be recorded. In this case, the [AUDIO INPUT/AUDIO MONITOR SELECT] indicator blinks.
  - Professional mode, CCIT J17
  - Consumer mode, data mode ON
  - Consumer mode, 4-channel mode

- **Digital audio signal output status bit**  
The sampling rate converter converts the digital audio signal output status bit from this unit to professional mode signals with a sampling frequency of 48 kHz and emphasis OFF regardless of the type of input signals.

## 8-1 PREPARATION FOR PLAYBACK

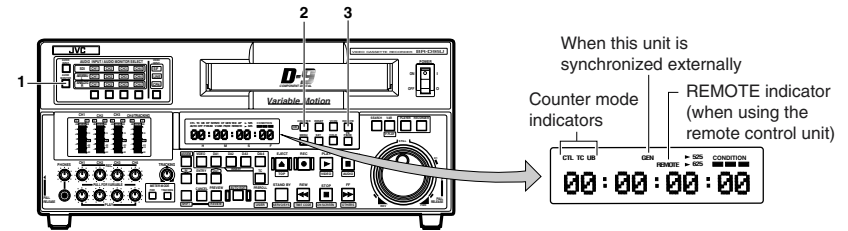
**Front panel switch setting****1. Select the audio monitor output.**

Select the audio monitor output from the rear panel [AUDIO MONITOR OUT] connectors or the front panel [PHONES] jack.

- For the selection procedure, refer to "Audio monitor output selection" on page 70.

**2. Set the tape counter mode.**

Set the time data to be shown on the counter display and the on-screen display. "CTL", "TC" or "UB" will be shown on the counter display.

**3. Engage the Remote mode.**

To operate this unit locally, press the [REMOTE] button so that the [REMOTE] indicator on the counter display goes out.

To operate this unit via the RS-422 or RS-232C serial remote interface, press the [REMOTE] button so that the [REMOTE] indicator lights.

**Menu switch setting**

Set the menu switches as required.

**• Reference sync signal items**

- Select the reference sync system.  
No. 003 <SYNC SELECT> ..... Page 43  
Set to "EXT" to synchronize with an external sync signal.

**• Tracking adjustment selection**

- Auto tracking/manual tracking selection  
No. 005 "AUTO TRACKING" .... Page 43
- **Video items**
  - Component video output level selection (NTSC only)  
No. 104 <CPN LEV./SETUP (525)> ... Page 44
  - Error correction mode selection  
No. 112 <ECC MODE> ... Page 45

**• Audio items**

- Audio V. fade function selection  
Select whether audio noise in transitions should be reduced or not.  
No. 214 <PBV. FADE> ..... Page 50
- Audio output level adjustment mode selection  
Select automatic or manual adjustment.  
No. 216 <AUD PB VOLUME MODE 1> ... Page 51
- Set the output to CH3 and CH4 when playing back a tape with two-channel audio (CH1 and CH2).  
No. 223 CH3/4 OUT SEL AT 2CH ... Page 52
- Audio output level setting  
Select the reference output level for the audio output connectors (CH1 to CH4) from +4 dB, 0 dB and -6 dB.  
No. 228 to No. 231 <AUDIO OUT LEVEL CH1 — CH4> ... Page 52
- Audio monitor output level setting  
Select the reference output level for the L and R audio monitor output channels from +4 dB, 0 dB and -6 dB.  
No. 232 to No. 233 <AUDIO MON LEVEL LCH — RCH>
- Auto Play mode selection  
Set whether the tape is automatically played back from the beginning or not.
- Output picture selection when playback starts  
Select the output picture that will be displayed until the servo has stabilized after starting playback.  
No. 368 <STARTING PIC FREEZE> ... Page 57
- Setting the video signal vertical blanking period masking  
No. 601 <V. BLANK MASK> ..... Page 64

## 8 PLAYBACK

### 8-2 BASIC PLAYBACK OPERATIONS

#### Notes

- Masking the video signal vertical blanking period  
If menu switch No. 601 <V. BLANK MASK> set to "ON (1)" or "ON WITH 0.5H (2)" the signal superimposed on the vertical blanking period will not be output. However, VITC or Extra line data will be output.
- Tracking adjustment  
For manual tracking adjustment, set the menu switch No. 005 <AUTO TRACKING> to "OFF (1)". The [TRACKING] button blinks when the level meter section shows the tracking meter.
- Output picture selection when playback starts  
Select the picture that will be output until the capstan servo and drum servo stabilize after playback starts with menu switch No. 368 <STARTING PIC FREEZE>.  
When this menu switch is set to "ON", the freeze picture displayed before playback starts is output. Once the servo is stabilized, output automatically switches to the playback picture.
- Play back the section of tape where control signals have not been recorded and set the picture output with menu switch No. 120 <NO CTL MUTING>.  
"OFF": A freeze picture is output.  
"ON": A black picture is output.
- Even if the frame is advanced periodically in the Still mode (every 5 minutes or so), the still mode will disengage after about 20 minutes to protect the heads and the VCR will automatically enter the Standby Off mode. The time that elapses until the frame is advanced can be selected with menu switch No. 307 <PAUSE/STILL/STP TIME>.

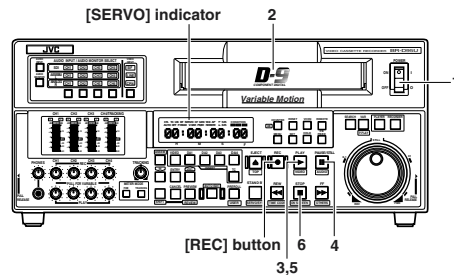

#### 1. Turn the [POWER] switch "ON".

#### 2. Load the cassette.

- When the tape is loaded, the [STANDBY] button lights to indicate that the Standby ON mode has been engaged.
- \* Be sure to use only **DIGITAL S** cassette tapes. VHS/S-VHS cassettes cannot be used.

#### 3. Start playback.

- Press the [PLAY] button.
- The [PLAY] button indicator lights and playback starts. The [SERVO] indicator lights and the picture stabilizes.

- If menu switch No. 005 <AUTO TRACKING> is set to "ON (1)", tracking is automatically adjusted. As a result, it takes several seconds for the picture to stabilize after the [SERVO] indicator lights. The [SERVO] indicator blinks until the servo stabilizes.
- The [525] or [625] indicator blinks on the counter display if you try to play back a tape not recorded in the same signal system as the one set for this unit.

#### 4. To temporarily stop playback

- Press the [PAUSE/STILL] button.
- The [PAUSE/STILL] button lights and the Still mode is engaged.

#### 5. To re-start playback

- Press the [PLAY] button.
- The [PAUSE/STILL] button goes out and playback resumes.

#### 6. To stop playback

- Press the [STOP] button.
- The [PLAY] button indicator goes out and the tape stops.
- When the [STANDBY] button is pressed, the [STANDBY] button goes out and the Standby OFF mode is engaged.

The Standby ON mode is automatically engaged when the tape ends. If menu switch No. 312 <AUTO REW> is "ON (1)", the tape is automatically rewound to the beginning.

#### To monitor input signal during playback

The input signal (both video and audio) can be monitored for as long as the [REC] button is kept pressed during playback.

**Please note that the Record mode is engaged if the [PLAY] button is pressed together with the [REC] button.**

## 8 PLAYBACK

### 8-3. AUDIO PLAYBACK LEVEL ADJUSTMENT

- Audio signal output levels can be adjusted.

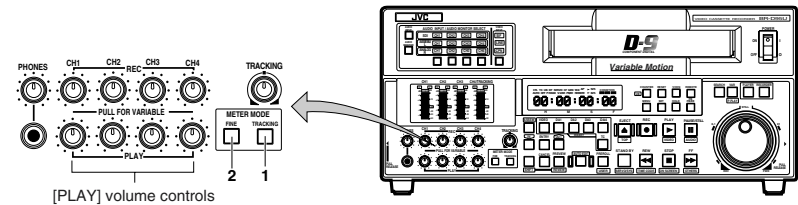

#### • Reference output level selection for the audio output connectors

Select the playback reference level for each channel from +4 dB, 0 dB and -6 dB with menu switch No. 228 to 231.

#### • Selecting signals for output from the CH3 CH4 audio connectors

When playing back a tape recorded on a 2-channel DIGITAL S VCR, use menu switch No. 223 <CH3/4 OUT SEL AT 2CH> to specify whether or not these signals are output from the audio CH3/CH4 connector.

- When menu switch No. 216 [AUD PB VOLUME MODE1] is set to "MAS-1 BAL-2/MAS-3 BAL-4", the master level adjust and balance adjust functions assigned to each volume control are enabled even if the corresponding channel is in the Unity mode.

- Playback levels can be adjusted either fixedly or manually.

To adjust the audio playback level, pull out the [PLAY] volume controls to engage the Manual mode or push them in to engage the Unity mode. Either mode can be selected independently for each audio channel.

#### Audio Playback Level Lock mode

Push in the [PLAY] volume controls to engage the Unity mode for playback level adjustment.

- In the Unity mode, the [P] indicator on the upper section of the meter lights. This means that adjustment is not possible with the [PLAY] volume controls.

#### Manual audio playback level adjustment

Pull out the [PLAY] volume controls to engage the Manual mode for playback level adjustment.

In the Manual mode, the [P] indicator on the upper section of the meter goes out.

There are two ways to adjust playback level manually.

- Adjust the audio level for each channel independently with the CH1 to CH4 [PLAY] volume controls.
- Use CH1 and CH2 [PLAY] volume controls as one pair and CH3 and CH4 [PLAY] volume controls as one pair. Adjust audio levels using the CH1 and CH3 [PLAY] volume controls as a master volume control and the CH2 and CH4 [PLAY] volume controls as a balance control.

Select the adjustment mode with menu switch No. 216 <AUD PB VOLUME MODE 1>.

#### ■ Menu switch setting

- Select the manual playback level adjustment mode with menu switch No. 216 <AUD PB VOLUME MODE 1>.  
"CH1/CH2/CH3/CH4 (0)": To independently adjust the playback level for each channel with the CH1 to CH4 [PLAY] volume controls.  
"MAS -1 BAL2/MAS-3 BAL-4 (1)": Use CH1 and CH3 [PLAY] volume controls for master volume control and the CH2 and CH4 [PLAY] volume controls for balance control.

The [PB UNITY] indicator goes out and the Manual Playback Level Adjustment mode is engaged.

## 8 PLAYBACK

### 8-3. AUDIO PLAYBACK LEVEL ADJUSTMENT

- The audio level meter's reference level indication changes depending on the setting of menu switch No. 257 <AUD REF. SIGNAL LEV.> (-20 dB or -18 dB).

#### 1. Set the [CH4/TRACKING] meter to audio level.



- When the [METER MODE TRACKING] button is illuminated or blinked, press the [METER MODE TRACKING] button.  
→ The [METER MODE TRACKING] button goes out and the [CH4/TRACKING] meter can be used for the CH4 audio level.

#### 2. Adjust the playback level for each channel (CH1 to CH4) separately with the [PLAY] volume control.

- To perform fine adjustment, press the [METER MODE FINE] button.  
→ The [METER MODE FINE] button is illuminated and the audio level meter shows a reference fine level of around -20 dBFS or -18 dBFS.

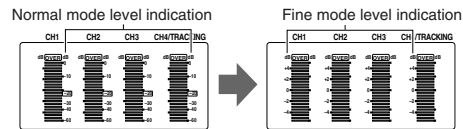

- The reference output level shown by the audio level meter is -20 dBFS or -18 dBFS.

#### ■ Adjust with the master and balance controls.

- The CH1 and CH2 [PLAY] volume controls, and the CH3 and CH4 [PLAY] volume controls work as one set.  
The CH1 and CH3 [PLAY] volume controls serve as master volume control and the CH2 and CH4 volume controls as balance control.
- Turn the CH1 or CH3 [PLAY] volume control.  
The audio on CH2 or CH4 changes along with CH1 or CH3.
  - Turn the CH2 or CH4 [PLAY] volume control to adjust the balance between CH1 and CH2 or CH3 and CH4.

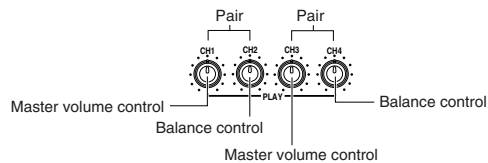

## 8 PLAYBACK

### 8-4 MANUAL TRACKING AJUSTMENT

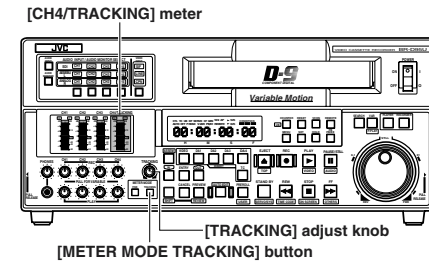

- In the Auto Tracking mode, the [METER MODE TRACKING] button lights.

This unit is equipped with an automatic tracking facility which operates during playback to maintain optimum tracking (with menu switch No. 005 <AUTO TRACKING> set to "ON (1)").  
With some tapes, noise may still appear — particularly if the tape was recorded on a different VCR. In this case, manual tracking adjustment is also possible.

- Set menu switch No. 005 <AUTO TRACKING> to "OFF (0)".
- Set the [CH4/TRACKING] meter for tracking.  
Press the right [TRACKING METER MODE] button.  
→ The [METER MODE TRACKING] button blinks when the meter is switched to Tracking mode.
- Adjust until the tracking meter level reaches the maximum.

The Auto Tracking mode can be restored by setting menu switch No. 005 <AUTO TRACKING> to "ON (1)".



## 8 PLAYBACK

### 8-5 ERROR CORRECTION

Error correction of digital playback signals is performed with the error correction circuit and the error conceal circuit.

**Error correction circuit** : Errors in playback data caused by dropouts or mis-tracking are corrected using the results of the data operation.

**Error conceal circuit** : Major errors that the error correction circuit cannot correct are concealed with the previous frame data.

Switching the setting of menu switch No. 112 <ECC MODE> turns the error correction circuit ON/OFF.

The relationship between the menu setting and error correction operation is shown in the table below.

Menu setting	Error correction circuit	Error conceal circuit
NORMAL	o	o
NO CONCEAL	o	x
NO CORRECTION	x	x

o : Activated  
x : Deactivated

- Normally set to "NORMAL (0)".
- Turning part or all of the error correct circuit OFF allows you to compare noise levels and check the head service life. For comparison, play back a moving picture.  
For example, when switching between "NORMAL" and "NO CONCEAL" shows a big difference in picture quality, it indicates that the error conceal circuit works and that a major error has occurred. In this case, **the heads may no longer be serviceable and should be replaced.**

### 8-6. AUDIO V. FADE FUNCTION

Major changes in waveforms during audio transitions may be heard as noise during playback. To reduce this noise, an Audio V. Fade function is provided. When this is operating, audio transitions are detected and the audio level is faded in a V shape during playback.

This function can be set with menu switch No. 214 <PBV. FADE>.

OFF (0) : The V. fade function is disabled.

5M (1) : The V. fade function is enabled and audio transitions are faded out and faded in for 5 msec to reduce noise. For best results, this position is recommended.

10M (2) : The V. fade function is enabled and audio transitions are faded out and faded in for 10 msec to reduce noise.

## 8 PLAYBACK

### 8-7 SIMPLIFIED PLAYBACK SPEED ADJUSTMENT FUNCTION

The playback speed can be increased or decreased in two ways (simplified playback speed adjustment function). When two VCRs are being played back, this function helps synchronize playback operation (sync operation).

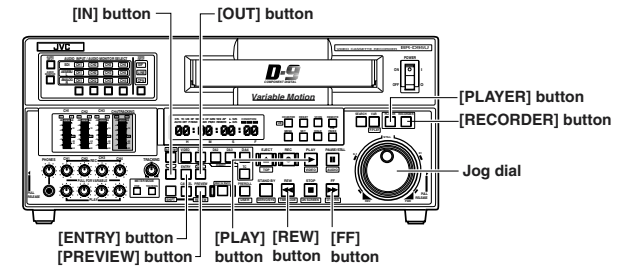

#### Increasing/decreasing the playback speed by 7%

1. During playback, press the [FF] or [REW] button while pressing the [PLAY] button.
  - **While the [FF] button is pressed: The playback speed is increased by about 7%.**
  - **While the [REW] button is pressed: The playback speed is decreased by about 7%.**
2. Operation differs depending on which button you release first.
  - **If you release the [PLAY] button first, playback speed increased/decreased by about 7% is maintained (Latch mode).**
    - To return to the normal speed, press the [PLAY] button again.
  - **If you release the [FF] or [REW] button first, the normal playback mode is restored.**

#### Synchronized Running mode

The tapes loaded on two VCRs can be played back in sync with the same time code data.

- **Connection**
  - Connect the [REMOTE IN] connector of the controlled VCR and the [REMOTE OUT] connector of the control VCR with a 9-pin cable.
  - Input external sync signals to synchronize the two VCRs.
- **Setting**
  - Set the Remote/Local switch to "Remote" on the controlled VCR and set the Remote/Local switch to "Local" on the control VCR.
- **Operation**
  1. Set menu switch No. 372 <P+R AT SWAP MODE> to "ENABLE".
  2. Press the [PLAYER] and [RECORDER] buttons at the same time. Both buttons light up.
  3. If the edit mode (assemble, insert) is selected, release it.
  4. Search the position from which you want to start playback using the control VCR's jog dial, etc.
  5. Press the [ENTRY] button while pressing the [IN] button to determine the edit IN point for synchronized playback.
    - The time code data determined by the control VCR is registered as the playback start point on the two VCRs.
  6. Press the [PREVIEW] button to start the synchronized tape running. The phase is adjusted just before the edit IN point for synchronization.

## 8-8 SHUTTLE SEARCH/JOG OPERATION

**Notes**

- Selecting modes in which Shuttle Search can be engaged.

With menu switch No. 301 <DIRECT SEARCH> set to "OFF (0)", Shuttle Search starts only when the [SEARCH] button is pressed.

When set to "ON (0)", Search can start from any mode except REC and REC Pause mode.

- **Maximum Search speed**  
X32, X17 or X6 speed can be selected with menu switch No. 340 <SEARCH SPEED>.

- Use menu switch No. 221 <SEARCH PB AT 1+3/2+4> to select whether or not audio is recorded on the cue track when menu switch No. 219 <SEARCH REC CH> is set to CH1+3/CH2+4.

- **Slow Picture mode**  
With menu switch No. 119 <SLOW PICTURE>

FRAME (0): Slow-motion frame playback

FIELD (1): Slow-motion field playback

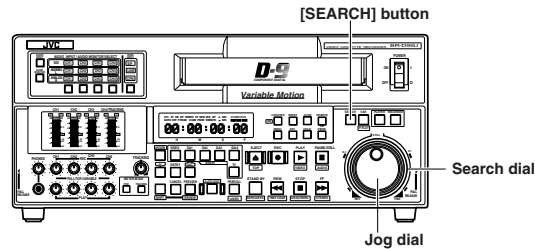

Rapid visual search can be performed with either of two concentric dials; the outer one serving as a shuttle search dial and the inner one as a jog dial.

- Audio recorded on the tape's longitudinal cue track or digital audio track is output during shuttle search and jog operation. (Select the audio during search with menu switch No. 216 <AUD SEL. AT SEARCH>.)

**Shuttle search control****1. Turn the outer dial in the Play/Still/Stop/FF/REW modes.**

Turn the dial to FWD (clockwise) to search in the forward direction and to REV (counterclockwise) to search in the reverse direction.

→ Search starts. Search speed changes as given below in both forward and reverse directions depending on how far the dial is turned.

Center (STILL) 0 → 0.03 → 0.07 → 0.10 → 0.20 → 0.50 → 1.00 → 2 → 4 → 6 → 10 → X32

The maximum search speed can be selected with the menu switch No. 340 <SEARCH SPEED>.

- The Still mode is engaged when the dial is set at the center still click position. Play speed is X1 (normal) at the first click position in both forward and reverse directions. Noiseless playback is available from about -1.0x to +1.0x. In this case, the audio signals on the digital track of tape are output.

**2. To stop search operation**

Press PLAY, STOP, FF, or REW depending on which mode is to be engaged next.

→ The selected mode is engaged. There is no change in the dial position. When the [SEARCH] button is pressed, search operation starts at the speed corresponding to the current position of the dial.

**Jog operation****1. Turn the inner jog dial.**

- Turn the dial in the FWD direction (clockwise) to advance the tape. Turn the dial in the REV direction (counterclockwise) to reverse the tape. Search speed corresponds to the speed with which the dial is turned.
- The Still mode is engaged whenever you stop turning the dial.

## 8-9 VARIABLE SLOW PLAYBACK

Noiseless variable slow playback from -1.0x to +1.0x is available. Triple-pair playback heads assure optimum picture quality.

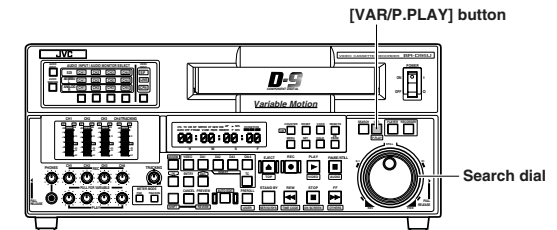

Variable slow playback can be executed using either of the two methods described below.

**Method 1**

1. Press the [VAR/P. PLAY] button to engage the Variable mode. The button lights.
2. Turn the search dial.  
Variable slow playback from -1 x to +1x is available.
  - Turning the search dial all the way in the REV direction gives you -1x speed. Turning it all the way in the FWD direction gives you +1x speed. When the search dial is set to "STILL", a still picture is displayed.
  - The variable slow playback speed is shown on screen.
3. To stop variable slow playback  
Press the operation button such as the [PLAY], [STOP], [PAUSE/STILL] and [SEARCH] buttons.

**Cautions**

- The V. fade function is enabled only in the Playback, Program Playback or Variable Slow Playback +1x mode. Under the following conditions, the V. fade function may also be disabled in the Variable Slow Playback +1x mode.
  1. In the first 15 seconds after the Variable Slow Playback +1x mode is activated.
  2. When playing a tape recorded on the BR-D40/DY-70 or some BR-D80/D85s.
- When playback speed is changed from + to - and vice versa, gray lines may appear at the top or bottom of the screen (except with normal D9-format video signals). This is normal. It is not a malfunction.
- Noise may appear when the Variable Slow Playback +1x mode is activated. This is normal. It is not a malfunction.

## 8 PLAYBACK

### 8-9 VARIABLE SLOW PLAYBACK

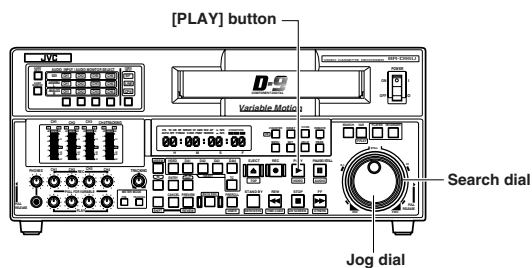

#### Method 2

Variable slow playback can be engaged during normal playback.

- To use this function, be sure to set the direct search function to OFF.
  - Set menu switch No. 301 <DIRECT SEARCH> to "OFF (0)".
- Press the [PLAY] button to engage the Play mode.
- When you want to start variable slow playback, hold the [PLAY] button down and turn the search dial.

The variable slow playback is executed in the range of +0.90x to +1.10x according to the turning direction and angle of the search dial.

- Turning the search dial all the way in the REV direction gives you +0.90x speed. Turning it all the way in the FWD direction gives you +1.10x speed. When the search dial is set to "STILL", the Normal Playback mode (x1.0) is engaged.
- Turning the search dial varies the playback speed in 1% steps. The variable slow playback speed is shown on screen.

- Release the [PLAY] button to restore the normal playback mode.

#### Method 3

Turn the jog dial while pressing the [PLAY] button during playback to increase or decrease the playback speed according to the jog dial's rotation direction and speed.

- Set menu switch No. 301 <DIRECT SEARCH> to "ON".
- To increase playback speed**
  - Turn the jog dial clockwise (in the FWD direction) while pressing the [PLAY] button. The playback speed can be increased up to 2 times normal depending on how fast you rotate the dial.
  - When you stop turning the jog dial, normal playback speed is restored.
- To decrease playback speed**
  - Turn the jog dial counterclockwise (in the REV direction) while pressing the [PLAY] button. The playback speed can be decreased until the tape stops depending on how fast you rotate the dial.
  - When you stop turning the jog dial, normal playback speed is restored.

- When variable-motion playback is performed at speeds outside the range from -1.0 x to +1.0 x, "!" appears with the operation mode display on-screen. This produces a distorted picture.

- Audio quality differs depending on the setting of menu switch No. 261 <AUD SEL. AT SEARCH>. When "DIGITAL AUDIO" is selected, audio will be distorted.

## 8 PLAYBACK

### 8-10 PROGRAM PLAYBACK

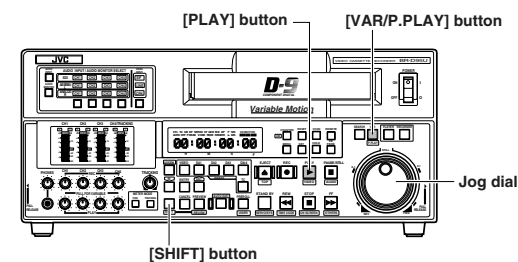

Counter display

P.PLAY 104.2%

PLAY +1.042  
TCR 00:00:00:01

The program playback function lets you vary tape playback speeds between +0.90x and +1.1x.

Program playback is possible after setting the initial speed value. During program playback, the playback speed can be varied.

#### Engage the Stop or Still mode.

- Engage the Program Playback mode. While holding the [SHIFT] button down, press the [VAR/P. PLAY] button.
  - The [VAR/P. PLAY] button blinks and the Program Playback mode is engaged.
- Set the program playback speed. While pressing the [VAR/P. PLAY] button, turn the jog dial.
  - Turn the jog dial to set the playback speed in the range of +0.90x to +1.1x. (0.1% step).
  - Turn the jog dial clockwise to accelerate the playback speed and counterclockwise to decelerate it.
  - The program playback speed is shown on the counter.
- Execute program playback. While holding the [VAR/P. PLAY] button down, press the [PLAY] button.
  - Playback continues at the set speed. During program playback, the [PLAY] and [VAR/P. PLAY] buttons blink.
- To change the playback speed during program playback, hold the [VAR/P. PLAY] button down and turn the jog dial.
- To stop program playback, press any operation button, i.e. [STOP], [PLAY], [PAUSE/STILL] and [SEARCH] buttons.

## 8 PLAYBACK

### 8-11 FF, REW AND COUNTER MEMORY FUNCTIONS

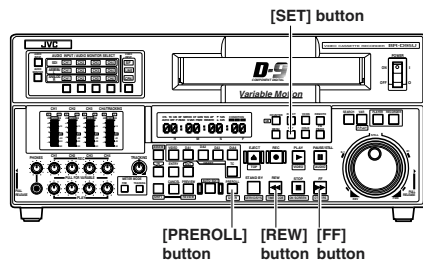

#### Notes

**Output mode selection in FF and REW modes**  
With menu switch No. 314 <PB/EE MODE> set to "STOP/FF/REW (0)", press the [PB/EE] button to engage the Still Output mode or EE mode.

**Auto REW function setting**  
With menu switch No. 312 <AUTO REW>

The tape is automatically rewound to the start when it comes to an end in the Play or Record mode.

#### ■ To fast-forward or rewind the tape

Press the [FF] or [REW] button.

→ The [FF] or [REW] button lights and the tape is fast-forwarded or rewound. Maximum FF and REW speeds can be set to 60 times, 32 times or 17 times normal with menu switch No. 319 <FF/REW MAX SPEED>. Factory setting: 60 times normal

#### ■ Counter memory function

##### Setting procedure

- Set the counter mode to "CTL" with the front panel [COUNTER] button.

##### Counter memory operation

- Specify a tape section to be recalled.  
Press the [RESET] button while pressing the [SET] button at the desired section.  
→ The counter is reset to "0:00:00:00" and this section is entered in this unit.  
\* When the counter display mode is set to "TC", the value at the specified point is entered.  
• Press the [SET] button to check the entered value on the counter display.
- Start Counter Search.  
In the Stop mode, press the [PREROLL] button while pressing the [SET] button.  
The tape fast-forwards or rewinds and stops automatically at or near counter 0:00:00:00 in CTL mode.  
In time code mode, the tape stops automatically at or near the entered value.

### 8-12 REPEAT PLAYBACK

With this function activated, tape playback is automatically repeated when the tape ends.

##### Setting

- Set menu switch No. 311 <AUTO PLAY> to "ON (1)"
  - Set menu switch No. 312 <AUTO REW> to "ON (1)"
- Start playback  
When the tape ends, it is rewound to the start and automatically begins playback. This procedure is repeated continuously.

## 9 OTHER FUNCTIONS

2 extra lines for color signals and 4 extra lines for black and white signals are provided for each frame. A data added to the V blanking section of input signals is recorded on the tape as an extra line. In the Play mode, this extra line information is added to the video signal for output.

### 9-1 EXTRA LINE DATA RECORDING/PLAYBACK

#### Extra line recording

Select the line containing the information to be recorded on an extra line.

#### 1. Setting the input signal line for extra-line recording

Select with menu switch No. 138 <EXTRA LINE REC>.

FIX (0)	NTSC: Records line 22 information in the input signal onto extra line-1 and line 284 information onto extra line-2. Factory setting.  PAL: Records line 22 information in input signals onto extra line-1 and line 623 information onto extra line-2. Factory setting.
USER SETTING (1)	Two user-specified lines in the input signal are recorded onto extra line-1 and 2 for color signal data. Four user-specified lines in the input signal are recorded onto the extra line-1 to 4 for black-and-white data. To specify the lines for color signals, set menu switches No. 139 and No. 140. For black-and-white signals, set menu switches No. 139 to No. 142.

#### 2. Selecting an input signal line when USER SETTING (1) is selected in Step 1.

- Set the line to record on extra line-1 with menu switch No. 139 <EXTRA-L R1 SEL> (color or black-and-white signal).
- Set the line to record on extra line-2 with menu switch No. 140 <EXTRA-L R2 SEL> (color or black-and-white signal).
- Set the line to record on extra line-3 with menu switch No. 141 <EXTRA-L R3 SEL> (black-and-white signal only).
- Set the line to record on extra line-4 with menu switch No. 142 <EXTRA-L R4 SEL> (black-and-white signal only).

## 9 OTHER FUNCTIONS

### 9-1 EXTRA LINE DATA RECORDING/PLAYBACK

#### Extra line data playback

- Menu switch indication for extra line  
NTSC: (525) is displayed after the menu switch name.  
PAL : p is displayed after the menu switch number and (625) is displayed after the menu switch name.
- For details of menu switches No. 143 to No. 147, refer to page 47–48.
- When menu switch No. 128 <PB EXTENSION LINE> is set to "ON", the extra line information in the video signal line is not output.

The menu switches below are used to select whether or not the extra line information should be added to the video signal during playback, and if so, how it should be added.

#### 1. Select how the extra line information is to be added to the playback video signal with menu switch No. 143 <EXTRA LINE PB>.

MUTING (0)	Extra line information is not added to output video signals. Factory setting.
AUTO (1)	When video signals are output, extra line information is added to the line selected for extra line recording.
USER SETTING (3)	When video signals are output, extra line information is added to the two user-specified lines. Color signal data is output on two lines and black-and-white signal data is output on four lines. To specify the lines for color signals, set menu switches No. 144 and No. 145. For black-and-white signals, specify the lines with menu switches No. 144 to No. 147.

#### 2. Select a line on which extra line information should be added to the playback video signal when USER SETTING (3) is selected in Step 1.

- Set the line for extra line-1 information with menu switch No. 144 <EXTRA-L P1 SEL> (color or black-and-white signal).
- Set the line for extra line-2 information with menu switch No. 145 <EXTRA-L P2 SEL> (color or black-and-white signal).
- Set the line for extra line-3 information with menu switch No. 146 <EXTRA-L P3 SEL> (black-and-white signal only).
- Set the line for extra line-4 information with menu switch No. 147 <EXTRA-L P4 SEL> (black-and-white signal only).

#### Notes on the extra line user setting

- Extra line information is not output if the selected lines are the same as those set with menu switch No. 400 and No. 401.

## 9 OTHER FUNCTIONS

### 9-2 EXTRA LINE, VITC LINE, V. BLANK MASK and PB EXTENSION LINE settings

Setting range and priorities for the following menu switches are shown below.

No. 138 to 147 EXTRA LINE, No. 601 V. BLANK MASK, No. 400 to 401 VITC LINE SELECT and No. 128 PB EXTENSION LINE.

#### ■ NTSC

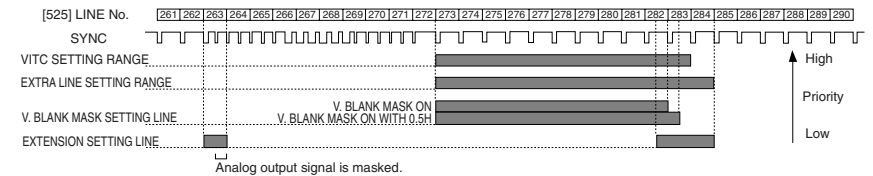
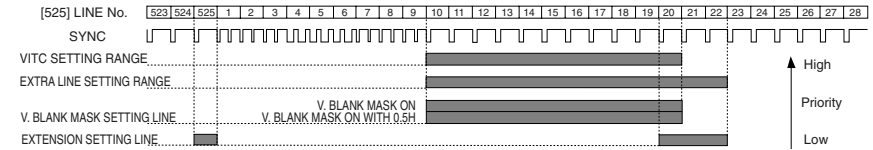

#### ■ PAL

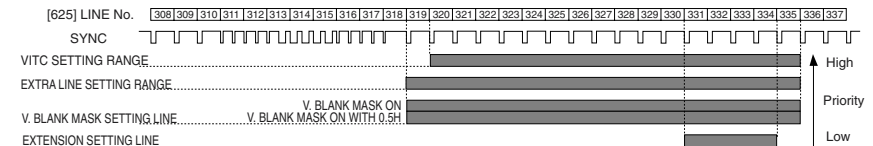
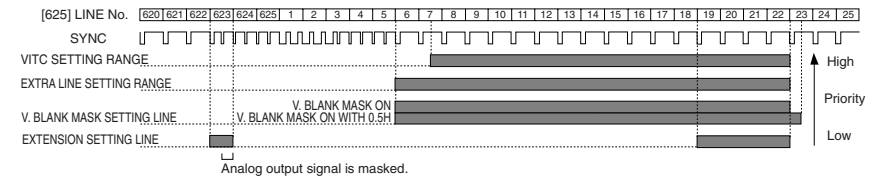

## 9 OTHER FUNCTIONS

### 9-3 SIMULTANEOUS OPERATION

More than one BR-D95U can be operated at the same time with one RS-422 serial remote controller.

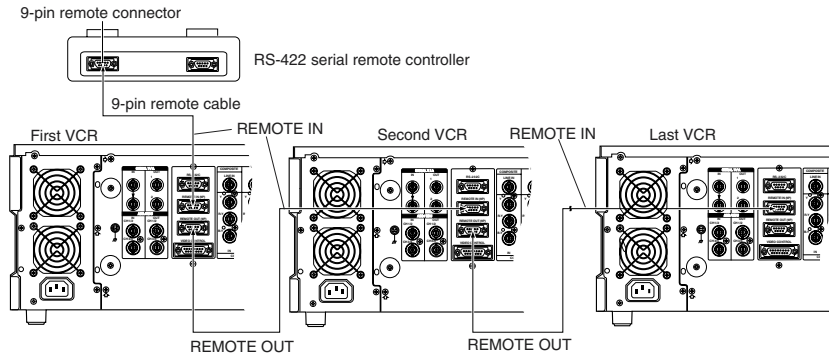

#### Connection

- Connect the 9-pin remote connector of the RS-422 serial remote controller to the first VCR's [REMOTE IN] connector.
- Connect the first VCR's [REMOTE OUT] connector to the second VCR's [REMOTE IN] connector with a 9-pin remote cable, the second VCR's [REMOTE OUT] connector to the third [REMOTE IN] connector, and so on.

#### Setting

Set the all connected VCRs as follows.

- Set menu switch No. 369 <PARA-RUN> to "ON (1)".
- Press the front panel [REMOTE] button to engage the VCR in the Remote mode (the "REMOTE" indicator lights on the display).

#### Operation

- Recording, playback, fast-forward and rewind on all the VCRs can be controlled at the same time with the RS-422 serial remote controller.

#### Simultaneous operation with the BR-D95U

When the BR-D95U is used instead of the RS-422 serial remote controller, set as follows.

- BR-D95U used for simultaneous operation (first VCR)
  - If you want to operate the first VCR at the same time, set menu switch No. 369 <PARA-RUN> on the first VCR to "ON (1)". If not, set to "OFF (0)".
  - Set the operation mode to "Local". Press the [REMOTE] button so that the "REMOTE" indicator on the display goes out.
- Second VCR
  - Set menu switch No. 369 <PARA-RUN> to "OFF (0)".
  - Set the operation mode to "Remote".
- Third and subsequent VCRs
  - Set menu switch No. 369 <PARA-RUN> to "ON (1)".
  - Set the operation mode to "Remote".

#### Operation

When the [PLAYER] button is pressed...

- If menu switch No. 369 <PARA-RUN> on the first VCR is set to "OFF (0)":
  - The [PLAYER] button is illuminated.
- If menu switch No. 369 <PARA-RUN> on the first VCR is set to "ON (1)":
  - The [PLAYER] and [RECORDER] buttons are illuminated.

Any operation executed on the first VCR will automatically be executed on all the other VCRs as well.

With a remote controller that requires the VCR to reply to commands, set menu switch No. 369 <PARA RUN> to "OFF" for the first VCR, and "ON" for the second and subsequent VCRs.

\*The recorder's variable playback speed is -1.0x to +1.0x. The player's variable playback speed is -2.0x to +3.0x.

## 9 OTHER FUNCTIONS

### 9-4 FIXED TIME CUE UP FUNCTION

The tape can be cued to the position whose time data (fixed time) is recorded with "00F: FIXED TIME ENTRY" on the top menu page (fixed time cue up function). Useful to cue up the tape to a specified position.

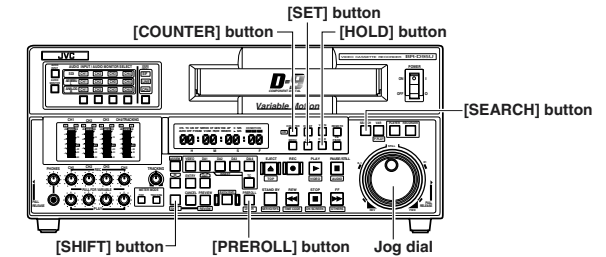

#### Registering the fixed time data

- Press the [MENU] button to display the menu setting screen.
- Turn the jog dial to select the top menu "00F: FIXED TIME ENTRY".
  - The time data currently registered is shown on screen.

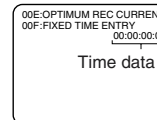

- Press the [HOLD] button.
  - The Fixed Time Data Registering mode is engaged and the time data currently registered is shown on the counter display.

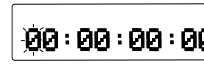

The uppermost digit blinks.

- The time data does not blink on screen. Register the time data on the counter display.

- Turn the jog dial to select the digit.
  - The selected digit blinks.
- Set the time data by turning the jog dial while pressing the [SEARCH] button.
- Repeat steps 4 and 5 to set the value for each digit.

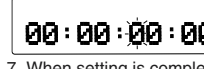

- When setting is complete, press the [SET] button.
  - "SET" is shown on the counter display.
  - The set time data is registered and the normal screen is restored.

#### Fixed time cue up operation

- Load a recorded tape.
- Select the counter display mode with the [COUNTER] button.
  - "TC" or "UB": The tape is cued up according to the time code registered on the tape.
  - "CTL": The tape is cued up according to the time data shown on the CTL counter.
- Press the [PREROLL] button while pressing the [SHIFT] button.
  - The tape is cued up to the registered position.

- In the Fixed Time Registering mode, press the [RESET] button to reset to "00:00:00:00".

- 00A: MENU in the top menu
  - Even though INITIAL is selected for SETTING, registered data is not reset.

- Checking the registered time data

The registered time data can be checked on screen by displaying "00F: FIXED TIME ENTRY". Press the [HOLD] button to display the registered time data on the counter display.

## 9 OTHER FUNCTIONS

### 9-5 MULTI CUE-UP FUNCTION

In the Multi Cue-Up mode, up to 8 cue points can be specified and cued up. To engage the Multi Cue-Up mode, set menu switch No. 389 <MULTI CUE MODE> to "ON".

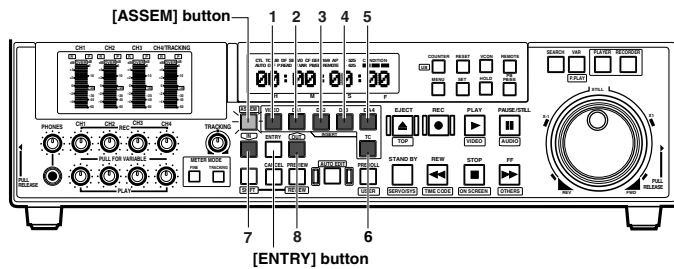

● In the Multi Cue-Up mode, recording and editing operations are disabled.

#### 1. Engage the Multi Cue-Up mode.

- Set menu switch No. 389 <MULTI CUE MODE> to "ON". The [ASSEM] button blinks and the Multi Cue-Up mode is engaged.

#### 2. Set the Counter mode to "TC" with the [COUNTER] button.

#### 3. Play back the tape. Pause the tape at the scene you want to specify as the cue point.

#### 4. Specify the cue point.

- Press the [ENTRY] button while pressing the [VIDEO] button. The first cue point is specified and the [VIDEO] button lights.
- To specify the second cue point, press the [ENTRY] button while pressing the [DA1] button.
- Up to 8 cue points can be specified with the button operation shown in the table below.

Cue point	Operation buttons	Display
1	VIDEO + ENTRY	The [VIDEO] button lights.
2	DA1 + ENTRY	The [DA1] button lights.
3	DA2 + ENTRY	The [DA2] button lights.
4	DA3 + ENTRY	The [DA3] button lights.
5	DA4 + ENTRY	The [DA4] button lights.
6	TC + ENTRY	The [TC] button lights.
7	IN + ENTRY	The [IN] button lights.
8	OUT + ENTRY	The [OUT] button lights.

#### ■ To check specified cue points

Press each button for which a cue point is specified. The time of the specified cue point is displayed on the counter display.

(e.g.) To check the third cue point, press the [DA2] button.

## 9 OTHER FUNCTIONS

### 9-5 MULTI CUE-UP FUNCTION

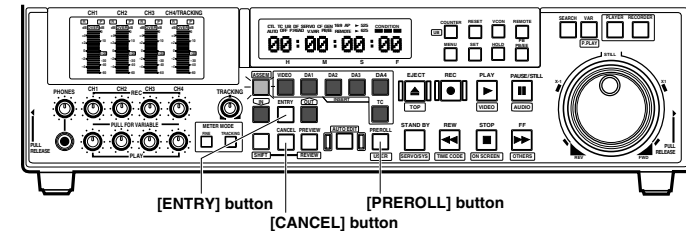

● When power is turned off, all specified cue points are cancelled.

● If the Multi Cue mode is engaged again before the power is turned off, the last cue point specified before the Multi Cue mode was previously disengaged can still be used.

#### ■ To change the specified cue point

Display the image at the cue point you want to change and press the [ENTRY] button while holding down the corresponding cue point button.

(e.g.) To change the fourth cue point

- Locate the cue point you want to change and press the [ENTRY] button while holding down the [DA3] button.

#### ■ To erase the specified cue point

While holding down the button corresponding to the cue point you want to erase, press the [CANCEL] button.

The corresponding button goes out and the cue point is erased.

(e.g.) To erase the 6th cue point

- While holding down the [TC] button, press the [CANCEL] button. The [TC] button goes out and the 6th cue point is erased.

#### 5. Perform the Cue-Up operation

Hold down the button corresponding to the required Cue-Up point and press the [PREROLL] button.

(e.g.) To Cue-Up the third cue point

- Hold down the [DA2] button and press the [PREROLL] button. The third cue point is cued up and the corresponding still picture is displayed.

#### 6. Quit the Multi Cue mode.

Set menu switch No. 389 <MULTI CUE MODE> to "OFF".

The [ASSEM] button goes out and the normal mode is engaged.

## 9 OTHER FUNCTIONS

### 9-6 STRIPING REC Function

When preparing a tape for editing, you can use this function to record the video signals, time code and user bits set with the <STRIPING REC MENU> on the entire tape.

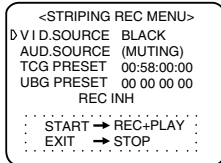

- After this operation, all buttons except for [EJECT], [STOP] and [REC] buttons have no effect.
- When the [STOP] button is pressed in this step, the menu is closed and the STRIPING REC mode is released.

- Audio signals are not recorded.
- Editing operations such as assembly and insert cannot be executed. If an operation other than the current mode is executed, for example when the [PLAY] button is pressed during rewind, STRIPING REC ends.
- When another operation is performed during recording ([REC] + [PLAY]), STRIPING REC ends.

#### Operation

1. If the [RECORDER] or [PLAYER] button is illuminated, press the button so that it goes off.
2. Press the [REMOTE] button to select the "LOCAL" mode for local operation.
3. Press the [REC] button while holding down the [SHIFT] button to open the <STRIPING REC MENU>.
  - The current settings are displayed on screen and the counter display.
  - The [REC] button blinks.
  - The Stop mode is engaged if the tape is running.
4. Load a cassette tape.
  - When the [REC] switch on the cassette is set to "OFF", "REC INH" blinks on screen.
5. Change the settings if required.
  - Refer to the menu setting contents and procedures on page 95. The settings are retained even if the power is turned off.
6. Press the [PLAY] button while holding down the [REC] button to start STRIPING REC.
  - The tape is rewound automatically to the beginning and recording starts.
  - During rewind, the [REC] and [REW] buttons blink alternately.
  - When recording starts, the blinking "STRIPING" indication lights. The [PLAY] and [REC] buttons blink simultaneously.
  - When the end of the tape is reached, "Complete" is shown on the counter display, the tape is automatically rewound to the beginning and STRIPING REC ends.
  - The following settings which are automatically set with the STRIPING REC are reset to the original settings when STRIPING REC is complete.
    - VIDEO INPUT) button
    - [COUNTER] button
    - TIME CODE) (INT/EXT, REC/FREE, PRESET/REGEN) switches
    - Menu switch No. 111 <VD REC SIGNAL SEL.>
    - If menu switch No. 457 <UB AUTO PRESET> is set to "ON", the registered user bit data is restored.
    - Audio muting is released.
7. Press the button on the front panel as required so that the "Complete" indication goes out.

## 9 OTHER FUNCTIONS

### 9-6 STRIPING REC Function

#### Menu setting details

On screen	Counter	Settings	Contents
VID. SOURCE	Video BLACK	BLACK SIF LINE CPN	Selects the video signals to be recorded. If non-input signals are selected, the indication blinks. BLACK: Selects the built-in black signal. The built-in color bar signal cannot be selected. SIF : Selects the AES/EBU signals. This cannot be selected if the SA-D95U is not installed. LINE : Selects composite signals. CPN : Selects component signals.
AUD. SOURCE	—————	(MUTING)	Muting is always on. Setting is not possible.
TCG PRESET	00:58:00:00	Desired value	Presets the time code.
UBG PRESET	00 00 00 00	Desired value (0 - F)	Presets the user bits.

#### Setting

1. Open the <STRIPING REC MENU>. Press the [REC] button while holding down the [SHIFT] button.
2. Turn the jog dial to select the item to be set.
3. Change the setting.
  - VID. SOURCE: Selecting the video signals  
While pressing the [SEARCH] button, turn the jog dial to select the signal.
  - TCG PRESET: Setting the time code
    1. Press the [HOLD] button.  
→ The digit for the time code blinks.
    2. Select the digit with the jog dial.  
→ The selected digit blinks.
    3. While pressing the [SEARCH] button, turn the jog dial to change the numeric value.
      - To cancel the setting, press the [HOLD] button.  
→ The menu item selection menu is restored.
      - To set all digits to 0, press the [RESET] button.
  - UBG PRESET: Setting the user bits
    1. Press the [HOLD] button.  
→ The digit for user bits blinks.
    2. Select the digit with the jog dial.  
→ The selected digit blinks.
    3. While pressing the [SEARCH] button, turn the jog dial to change the numeric value.
      - To cancel the setting, press the [HOLD] button.  
→ The menu item selection menu is restored.
      - To set all digits to 0, press the [RESET] button.
    4. Press the [SET] button to register the setting.
4. End menu setting.
 

It is not necessary to end menu setting to start STRIPING REC right away. Press the [STOP] button to close the menu and restore normal operation.

#### Non-drop frame/drop frame indication (NTSC only)

Set with the menu switch No. 416.  
Drop frame:  
00:00:00:00  
Non-drop frame:  
00:00:00:00

- Dropped data cannot be set in the Drop Frame mode. Data has 2 frames which are added (in the Drop Frame mode).



# 10 HOW TO USE TIME CODE

Time codes and user bits can be recorded and played back as time data. The time code area on the tape is divided into the main time code sector used for time data for editing and the sub time code sector which can be used for optional recording of time code.

## 10-1 TIME CODE DISPLAY

- Notes**
- On-screen display data are output through the rear panel [LINE2-SUPER] connector. (When the [ON SCREEN] switch on the sub panel is set to ON.)
  - The on-screen display position can be moved with menu switches No. 501 and 502.

- Time code reader data display during slow play of  $\pm 1.0$  times normal or slower 1st field or 2nd field is shown.
  - TC1: 1st field
  - TC2: 2nd field

- User bits**
- User bits are provided to allow user-specified data to be included in the time code data. User bits are recorded and played back with the time code. User user bits can be preset, recorded, played back, and displayed.
- The user bits set for each VCR can be recorded at all times (UB PRESET AUTO).
  - However, you cannot set sub time code user bits.

To display selected time data on the counter display and the on-screen display during playback or recording.

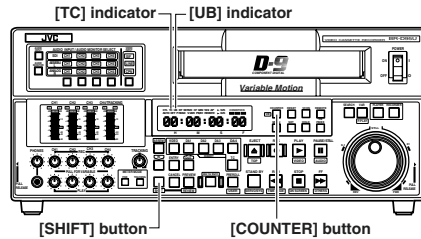

- Set the COUNTER switch to TC or UB.
  - Set the counter to the Time Code Display mode with the [COUNTER] button.
  - Press the [COUNTER] button while pressing the [SHIFT] button to set the counter to the User Bits Display mode. "TC" or "UB" is shown on the display depending on the setting.

TC: Displays time code data.  
UB: Displays user bits.

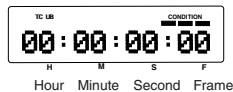

- TCR : Time code reader data (see the left column)
- TCG : Time code generator data
- UBR : User bits reader data
- UBG : User bits generator data
- TCR • : CTL (control) signal interpolation mark

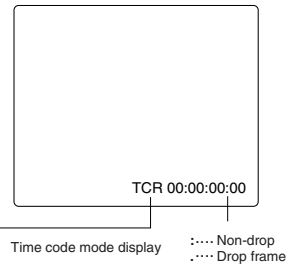

### Sub time code data display

Sub time code, marked with "SUB", is displayed with the main time code on the on-screen display.

- Sub time code is shown when:
  - Sub time code is output through the VITC output (with menu switch No. 504 <INFORMATION SELECT> set to "TIME+SUB TC (3)" or "TIME+SUB TC+MODE (4)").

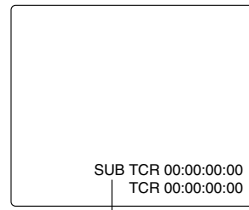

SUB: Sub time code

# 10 HOW TO USE TIME CODE

## 10-2 TIME CODE INITIAL SETTING (PRESET)

The BR-D95U includes a built-in time code generator so that initial values can be set as desired for the time code and user bits. User bit data is stored in the built-in nonvolatile memory and retained even when the power is turned off. The stored data can be preferentially recorded on the tape for editing (UB auto preset function).

- Drop Frame/Non-Drop Frame mode (NTSC only)**  
In the NTSC system, the actual number of frames per second is approximately 29.97. However, the number of frames used by the time code processing standard is 30. To compensate for this difference, the Drop Frame mode drops the 00 frame and the 01 frame once every minute (except the tenth minute). In the Non-Drop Frame mode, no frames are dropped and the difference between actual tape time and the time code is ignored.
- In the Drop Frame mode, the front panel [DF] indicator lights.

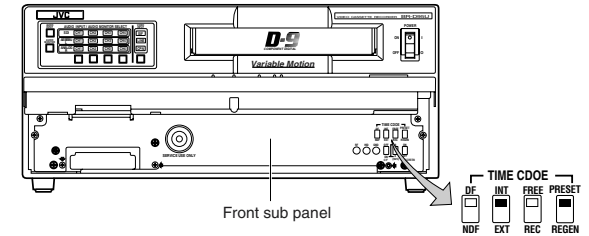

### Setting

#### Front sub panel switches for time code setting

- Set the [PRESET/REGEN] switch to "PRESET".
- Set the [REC/FREE] switch as desired.
  - REC: Time code preset in the time code generator runs in the Record mode. FREE: Time code runs from the preset point in the time code generator.
- Set the [INT/EXT] switch to "INT".
- Set the [DF/NDF] switch as desired. (NTSC only):
  - DROP (0) : Sets the Running mode of the built-in time code generator to the Drop Frame mode.
  - NON DROP (1) : Sets the Running mode of the built-in time code generator to the NON Drop Frame mode.

#### Front panel setting

- Select the Counter Display mode to TC or UB.

#### Menu switch setting

- Menu switch No. 457 <UB PRESET AUTO> setting  
When user bit data is preset from the 9-pin remote controller, set this to "OFF". When this is set to "ON", user bit preset data from the 9-pin remote controller is ignored.

10-2 TIME CODE INITIAL SETTING (PRESET)

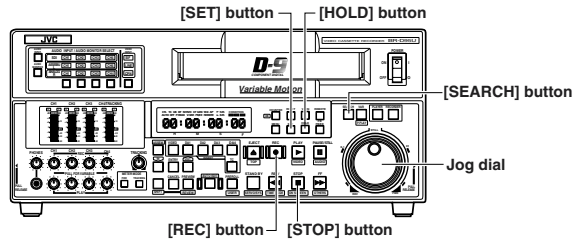

- Notes**
- To cancel a setting, press the [HOLD] button before the [SET] button has been pressed.
  - In the preset mode (steps 1 to 4), press the [RESET] button to set all digits to "0".
  - Time code data starts running as soon as presetting is finished if the front sub panel [FREE/REC] switch is set to "FREE".

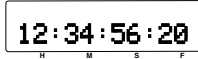
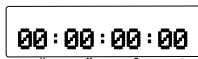
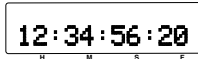
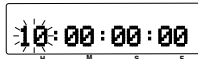
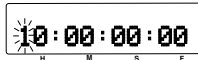
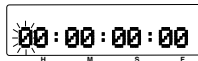

**Procedure**

- Engage the Time Code Generator Preset mode.**  
Press the [HOLD] button.  
→ The first digit on the counter display blinks.
- Set the value for the blinking digit by turning the jog dial while pressing the [SEARCH] button.**  
→ The value of the blinking digit changes. Use the hexadecimal (0-9, A-F) for user bits.
- Shift the digit by turning the jog dial.**  
→ The blinking digits shift to the next one.
- Set desired values for all digits.**  
Repeat steps 2 - 3.
- Presetting is completed by pressing the [SET] button.**  
→ The selected data are preset in the built-in time code generator. When preset is finished, the normal on-screen and counter displays are restored.

The user bit data is stored in the built-in memory.

**Checking the values set in the time code generator**

- Procedure**  
(Do this with the tape unloaded or in the Stop mode)
- Press the [REC] button to show the value set in the time code generator.**  
To check the user bit data stored in the built-in memory, set the counter display mode to "UB" and menu switch No. 457 <UB PRESET AUTO> to "ON (1)".
  - Pressing the [STOP] button restores the normal display mode.**

10-3 TIME CODE RECORDING

There are two different ways of recording time code or user bits; recording the data output from the built-in time code generator and recording externally generated time code or user bits. The user bit auto preset function allows preferential recording of data stored in the built-in nonvolatile memory.

**Recording time code data output from the built-in time code generator**

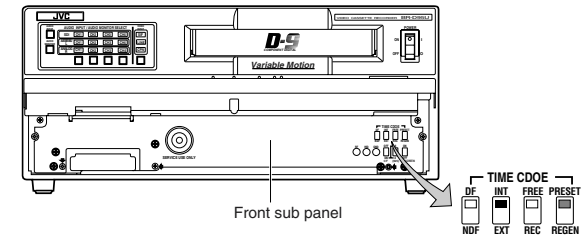

**Setting**

**Front sub panel switch setting**

Contents of the time code	Switch setting		
	[INT/EXT]	[REC/FREE]	[PRESET/REGEN]
Time code preset in the built-in time code generator is recorded.	"INT"	"REC" or "FREE"	"PRESET"
Recorded in sync with the time code recorded on the tape.	"INT"	"REC" or "FREE"	"REGEN"

**Menu switch setting**

- Menu switch No. 403 <REGEN MODE>: Set as desired in the Regen mode.
- Menu switch No. 450 <SUB TC (VITC) REC>  
When set to OFF (0): "00:00:00:00" is always recorded on the sub time code.  
When set to ON (1): Input VITC is recorded in the sub time code.  
Factory setting: ON (1)
- Setting of menu switch No. 457 <UB PRESET AUTO>  
OFF (0): The user bit auto preset function is disabled. The user bit data from the built-in time code generator is recorded.  
ON (1): The user bit auto preset function is enabled. The user bit data stored in the built-in memory is recorded.

**Procedure**

- Press the [REC] button in the Stop mode and check the value of the built-in time code generator.**  
→ The data value stays on display when the [REC] button is pressed.
  - Press the [STOP] button to restore the normal display mode.
- Record the time code and user bits.**  
→ Press the [PLAY] button while pressing the [REC] button.
  - TCG or UBG is shown on the on-screen counter display.
- To stop recording, press the [STOP] button.**

## 10 HOW TO USE TIME CODE

### 10-3 TIME CODE RECORDING

#### Recording the time code data output from the external time code generator

Externally generated time code can be recorded after being regenerated with the time code data output from the built-in time code generator.

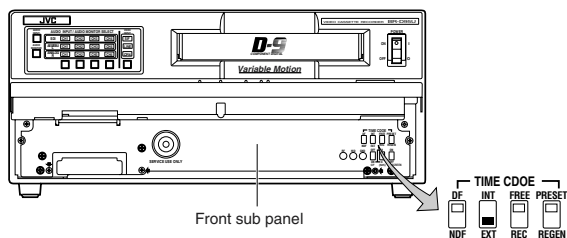

#### Notes

- Drop/Non-drop Frame mode selection (NTSC only)  
Automatically selected according to the mode of the received time code (Drop Frame or Non-drop Frame).
- Regeneration operation  
• When time code is being regenerated with input time code, the built-in time code generator stops counting when no time code is input.
- In the Play mode, time code regeneration is based on the playback time code value.
- Inserting time code  
If only time code data is being inserted, record it on the main time code. It is not possible to insert it in the sub time code.

#### 1. Front sub panel switch setting

- Select the External Time Code Generator mode by setting the [INT/EXT] switch to "EXT".  
The [FREE/REC] and [PRESET/REGEN] switch settings are not necessary.
- Select the Counter Display or On-screen Display mode to TC or UB with the [COUNTER] and [SHIFT] buttons.

#### 2. Menu switch setting

- Select the external time code to be regenerated.
  - Menu switch No. 409 <EXT REGEN TC> (Initial setting: LTC (0))  
LTC (0): Regenerates the LTC time code input through the rear panel [TC IN] connector.  

Input LTC time code should be regenerated (matched in terms of sync and phase) with video signals. Make sure you input an external sync signal to the feeding equipment.
  - VITC (1): Regenerates the VITC time code superimposed on the video signal input through the rear panel VIDEO IN connector.
- User bit data selection
  - Menu switch No. 457 <UB PRESET AUTO> (initial setting OFF (0))  
OFF (0): User bits regenerated by the time code generator of this unit is recorded.  
ON (1): The user bit auto preset function is activated and the user bit data stored in the built-in memory is recorded.
- Select the sub time code.
  - Menu switch No. 450 <SUB TC (VITC) REC> (Initial setting: ON(1))  
OFF (0): "00:00:00:00" is always recorded on the sub time code.  
ON (1): Records the input VITC time code in the sub time code.

#### 3. Record the time code.

Press the [PLAY] button while pressing the [REC] button.  
→ The selected time code will be recorded.

## 10 HOW TO USE TIME CODE

### 10-4 TIME CODE PLAYBACK

Time code is output through the rear panel [TC OUT] and [VIDEO OUT] connectors during playback. VITC time code with the time code data superimposed on the video signal is output through the [VIDEO OUT-LINE] connector. Sub time code is output through the [VIDEO OUT-LINE] connector as VITC time code when menu switch No. 451 <VITC OUT SELECT> is set to "SUB TC". Only the main time code is output through the [TC OUT] connector.

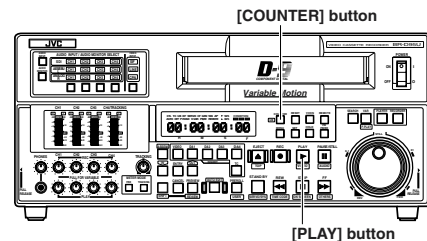

#### Setting

#### 1. Front panel switch setting

- Select a Counter Display mode to TC or UB with the [COUNTER] and [SHIFT] buttons.

#### 2. Menu switch setting

- For VITC time code output, select a line to be added to the video signal.
  - Menu switch No. 400 <VITC LINE-1 SELECT> (Initial setting: NTSC 16 LINE/PAL 19 LINE)
  - Menu switch No. 401 <VITC LINE-2 SELECT> (Initial setting: NTSC 18 LINE/PAL 21 LINE)
- Select VITC time code output through the [VIDEO OUT] connector.  
Menu switch No. 451 <VITC OUT SELECT>  
SUB TC (0) : Outputs the VITC time code recorded in the sub time code.  
TC (1) : Outputs the time code recorded in the main time code.  
OFF : VITC time code is not output from the [VIDEO OUT] connector.  
Factory setting : TC (1)
- Select the Time Code Output mode during search.  
Menu switch No. 452 <SEARCH LTC>  
OFF (0) : Outputs time code through the [TC OUT] connector during search at X1.  
ON (1) : Outputs time code through the [TC OUT] connector during search at all speeds. Continuous time code is not available.

#### 3. Play back the time code.

Press the [PLAY] button.

→ The selected time code is played back.  
TCR or UBR is shown with the on-screen time code data.

- LTC time code is output from the [TC OUT] connector.
- Main or sub time code selected with menu switch No. 451 <VITC OUT SELECT> is superimposed on video signals and output to the line selected with menu switch No. 400 and No. 401 from the [VIDEO OUT] connector.

- When you are using this deck as a player, the recording time code may not be regenerated when you output embedded audio (SERIAL V/A OUT) signals to the BR-D750U, BR-D85U or BR-D80U. In this case, set menu switch No. 237 <EMBEDDED AUDIO> to "OFF".

- On-screen display of sub time code  
Sub time code is displayed with the main time code when menu switch No. 451 <VITC OUT SELECT> is set to "SUB TC (0)".

## 10 HOW TO USE TIME CODE

### 10-5 SUB TIME CODE RECORDING AND PLAYBACK

In addition to the main time code used for editing, this unit can also record (and play back) an optional sub time code in the time code data area on the tape.

#### Notes

- When menu switch No. 450 <SUB TC<VITC> REC> is set to "ON (1)" the sub time code is regenerated with the VITC signal superimposed on the video signal from the [VIDEO IN] connector.

- [TC OUT] connector output**  
No sub time code data is output through the rear panel [TC OUT] connector. Only main time code (LTC) is output from the built-in time code reader.

#### Recording sub time code

- In the sub time code sector, you can record either the same data as in the main time code or the VITC time code received through the [VIDEO IN] connector.

##### 1. Select data to be recorded on the sub time code.

- Menu switch No. 450 <SUB TC (VITC) REC>
    - OFF (0): "00:00:00:00" is always recorded on the sub time code.
    - ON (1): Records the VITC received from the [VIDEO IN] connector on the sub time code.
- Initial setting: ON (1)

##### 2. Record the sub time code.

- Press the [PLAY] button while pressing the [REC] button. The selected time code will be recorded.

#### Play back the sub time code.

- Sub time code data is output through the [VIDEO OUT] connector as a VITC time code signal superimposed on the video signal.

##### 1. Enable sub time code playback.

- Set menu switch No. 451 <VITC OUTSEL> to "SUB TC (0)".  
Factory setting: TC (1)

##### 2. Play back the sub time code.

- Press the [PLAY] button.
  - Sub time code data is output through the [VIDEO OUT] connector as a VITC time code signal superimposed on the video signal.
  - Sub time code data (indicated with SUB) is shown with the main time code on the on-screen display (with menu switch No. 504 <INFORMATION SELECT> set to "TIME+SUB TC (3)" or "TIME+SUB TC+MODE (4)").

#### Time Code Signal Flow

Time code data flow depends on the setting of the menu switch or the [INT/EXT] switch.

Use this as a reference for switch setting.

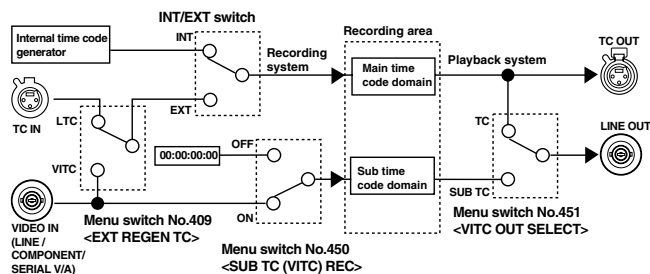

## 10 HOW TO USE TIME CODE

### 10-6 TIME CODE SWITCH SETTING FOR EDITING

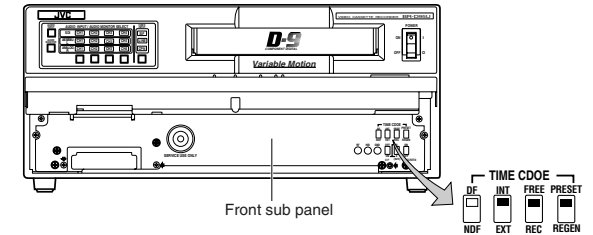

- Set the switches on the BR-D95U (recording VCR) as follows.

#### Front panel switch setting

- [INT/EXT] switch: Set to "INT".
- [REC/FREE] switch: Set to "FREE".
- [PRESET/REGEN] switch: Set to "PRESET".
- Set the menu switches as required.
- When menu switch No. 457 <UB PRESET AUTO> is set to "ON (1)", the user bit data stored in memory is recorded.

- Send an external sync signal to the [VIDEO REF IN] connector for editing.

Deliver a black burst or a standard color signal as an external sync signal.

#### Note

If there is no external sync signal generator available, send a video input signal to the [VIDEO REF IN] connector on the recording VCR.

# 11 EDITING

## 11-1 OUTLINE

Two electronic editing modes are available: insert editing and assemble editing. Signals from a video camera, on-air signals and playback signals from another VCR can be used in either type of editing.

### Assemble editing

With assemble editing, scenes are added one after the other in predetermined order. Video, audio, and control signals are recorded simultaneously. To ensure stable editing, CTL signals must be recorded prior to the first edit point for a period exceeding the preroll time (typically, about 30 seconds).

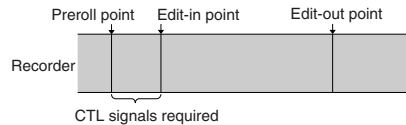

\* Since the full erase head operates during assemble editing, a non-recorded segment is produced after the postroll point. If assemble editing is applied in the middle of a recorded tape, the picture will be distorted after the postroll point.

- To record CTL signals, record a black picture from the built-in signal generator or connect a camera or a standard TV signal generator and record the output signals.
- Editing is not possible from the very beginning of the tape. The first edit-in point must be registered after the preroll section.
- Audio signals are not output when color bar signal from the built-in signal generator are inserted for editing (including preview). Do not select the audio channel for insertion of the color bar signal from the built-in signal generator. It may not be possible to insert the signal properly on the audio channel.

### Preroll time

It takes a few seconds for the tape to stabilize after tape running is started. To ensure that the tape is stable before it reaches the edit point, the tape must start running a few seconds before the edit-in point (prerolling).

- Select the preroll time from 0 to 15 seconds with the recorder's menu switch No. 320 <PREROLL TIME>. Use the remote control setting only when executing editing via a remote controller.
- CTL counter values based on the TIMER-1 PRESET command (44.00) from the editing controller can be preset only in the Non-drop Frame mode (NTSC).

### Insert editing

Insert editing allows you to insert new audio or video material between existing scenes that have already been recorded. You can choose different video and audio and combine them for insertion. CTL signals must be recorded continuously in the section where the new material is being inserted. Before editing, record CTL signals for a period exceeding the editing time.

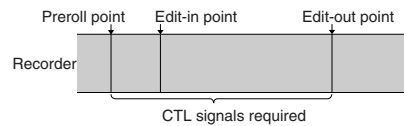

- Program Playback speed can be varied between 90% and 110%. The range is always the same even if an external controller or other unit is connected that sets the range outside this limit.

### Cautions

- The displayed image may be distorted when the editing mode is preset from an editing controller during editing or the mode is switched between EE and PB. This is normal. It is not a malfunction. The distortions appear in the editing output image but are not recorded.
- The V. Fade function may not function correctly when a tape with edited audio is played back. This is normal. It is not a malfunction.
- Noise may be recorded if all insert modes are canceled during editing with any of editing mode select buttons. This is normal. It is not a malfunction.
- Noise may be heard when editing is on or off in the Playback mode. This is normal. It is not a malfunction.

# 11 EDITING

## 11-2 COLOR FRAME SERVO SETTING

NTSC : 4-field color frame servo function available  
PAL : 4 or 8-field color frame servo function available

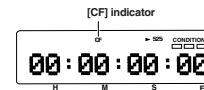
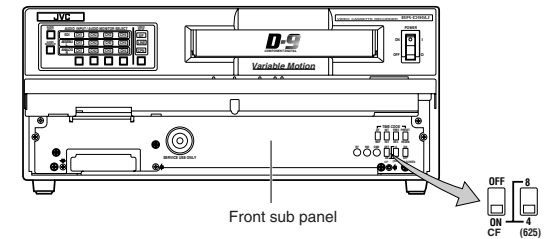

### Color frame-related menu switches

- No. 009 <CAP RE-LOCKING DIR.> Selects the direction of the color frame servo lock.
- No. 387 <CF FLAG REPLY> Selects the field unit for the color frame flag transmitted from the 9-pin remote control connector. (See page 106.)
- No. 421 <TCG CF FLAG> Turns the color frame flag for the time code bit ON/OFF. (See page 106)
- Color frame editing is still possible even when material that does not contain color frame information (have no 4-field NTSC color frame information or 8-field PAL color frame information) is inserted in a color frame-recorded section. Once the new material has been inserted, color frame editing can be performed by re-editing. In this case, the [CF] indicator on the main unit lights.

### Recording

- Color frame information is always recorded regardless of the setting of the front sub panel's CF switches and menu switches (except during editing).  
NTSC : 4-field color frame  
PAL : 8-field color frame
- During recording, the CF indicator lights on the counter display.
- If you want to synchronize time code with color frame, set menu switch No. 421 <TCG CF FLAG> to "ON" or "AUTO".

### Playback

The color frame servo function can be set with the front sub panel's CF switches and menu switches.

- Front sub panel switch setting
  - Set menu switch No. 008 <CAP LOCK (525)> or No. 008p <CAP LOCK (625)> to "SW SEL".
  - Set the [CF] switch on the front sub panel to "ON".  
For PAL, select the 4 or 8-field color frame servo with the [4/8] switch. When the [CF] switch is set to "OFF", the frame servo is activated.

### Menu switch setting

- For NTSC, set menu switch No. 008 <CAP LOCK (525)> to "4FIELD".
- For PAL, set menu switch No. 008p <CAP LOCK (625)> to "4FIELD" or "8FIELD".

### Menu switch No. 008 <CAP LOCK>

- SW SEL : Select with the front sub panel's [CF] switches.
- 2FIELD : Playback is performed with the 2-field servo system. Color framing is not executed.
- 4FIELD : Playback is performed with the 4-field color frame servo system.
- 8FIELD : Playback is performed with the 8-field color frame servo system (PAL only).

### [CF] indicator

If the front sub panel [CF] switches are set to any position except OFF, the CF indicator lights whenever a tape with color frame information is played back.

— Editing precision during color frame editing —

When the color frame servo function is used, the edit point may shift to maintain color frame continuity even though menu switch No. 393 <SYNC GRADE> is set to "ACCURATE".

11-2 COLOR FRAME SERVO SETTING

■ Color frame reference

VIDEO IN REF IN	LINE IN color signal input			LINE IN monochrome input COMPONENT IN SDI IN	
	REC	EDIT PB	PB	REC	PB
REF IN is Gen locking	LINE IN	LINE IN	REF IN	REF IN	REF IN
REF IN is not Gen locking			Internal reference signal	Color frame information is recorded according to the time code.	Internal reference signal

The color frame sync condition of the playback shown in the table above changes depending on the setting of menu switch No. 008 <CAP LOCK>.

■ TC color frame flag setting

- The time code color frame flag can be set and recorded only when the front sub panel's [TIME CODE] switches are set as follows.

[INT/EXT] switch : INT  
[PRESET/REGEN] switch : PRESET

When the [TIME CODE] switches are set as above, the time code color frame flag is recorded according to the setting of menu switch No. 421 <TCG CF FLAG MODE>.

Menu switch NO. 421 <TCG CF FLAG MODE>	During playback		During EE output	
	TCG CF FLAG setting		CF FLAG being recorded on tape	
OFF	OFF information is output	OFF information is output	OFF information is recorded	
ON	ON information is output	ON information is output	ON information is recorded	<ul style="list-style-type: none"> <li>• When recording time code with the [INT/EXT] switch set to "INT" and the [PRESET/REGEN] switch set to "PRESET" (except in editing). * Time code is based on the information recorded before the recording is paused. (i.e. "REC" → "PAUSE" → "REC") with the REGEN or REC RUN setting.</li> <li>• To record time code during assemble or time code insert editing (with tape recorded on BR-D95U). * Set menu switch No. 410 &lt;AUTO REGEN MODE&gt; to a valid setting (or set to "OFF" if the [PRESET/REGEN] switch is set to "REGEN") and the [INT/EXT] switch is set to "INT" under the 4-field (8-field in PAL) color frame servo.</li> </ul>
			OFF information is recorded	<ul style="list-style-type: none"> <li>• When recording time code under any conditions except those described above.</li> </ul>
AUTO	The information recorded on the tape is output.	The same setting as the one of TCG CF FLAG being recorded on the tape is output.	ON information is recorded	<ul style="list-style-type: none"> <li>• When recording time code with the [INT/EXT] switch set to "INT" and the [PRESET/REGEN] switch set to "PRESET" (except in editing). * Time code is based on the information recorded before the recording is paused. (i.e. "REC" → "PAUSE" → "REC") with the REGEN or REC RUN setting.</li> <li>• To record time code during assemble or time code insert editing (with tape recorded on BR-D95U). * Set menu switch No. 410 &lt;AUTO REGEN MODE&gt; to a valid setting (or set to "OFF" if the [PRESET/REGEN] switch is set to "REGEN") and the [INT/EXT] switch is set to "INT" under the 4-field (8-field in PAL) color frame servo.</li> </ul>
			OFF information is recorded	<ul style="list-style-type: none"> <li>• When recording time code under any conditions except those described above.</li> </ul>

\* The set time code value may shift when menu switch No. 421 <TCG CF FLAG MODE> is set to "ON" or "AUTO" and recording is performed with TC PRESET.

■ 9P color frame flag

9P color frame flag is set when the setting of menu switch No. 387 <CF FLAG REPLY> matches that of menu switch No. 008 <CAP. LOCK>.

11-3 SWAP EDITING

This unit is provided with a SWAP editing function which enables automatic editing without a controller. When this unit is connected to a player provided with a RS-422 serial remote connector (9-pin), you can operate both units using the recorder's controls.

An on-screen function allows you to check editing data for faster, more efficient editing. During swap editing, all the player can be operated from the recorder.

Editing procedure

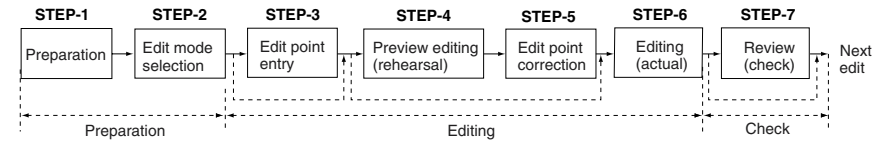

- When only edit start is performed automatically, steps 4, 5 and 7 can be omitted depending on the editing method (for example, preview editing is not required).

STEP-1 preparation

Connection

- Make sure all video and audio input/output connectors are properly connected.
- Connect the BR-D95U's [REMOTE OUT(9P)] connector to the player's RS-422 serial remote connector with the 9-pin remote cable.

Setting

■ Setting the player

- Set the VCR operation mode to the REMOTE mode.
- Adjust the video control parameters.
- Adjust the playback level with the audio playback level adjust knobs (this is not necessary for UNITY).
- Set the edit OUT point registering method with menu switch No. 373.

■ Setting the recorder

- **Front panel setting**
  - Set the VCR operation mode to "Local" with the [REMOTE] button (the [REMOTE] indicator on the display goes out).
  - Select the input signal with the video and audio input signal select buttons.
  - Adjust the recording level with the audio recording level adjust knobs (this is not necessary for UNITY).
  - Set the counter mode with the [COUNTER] button.
- **Front sub panel setting**
  - Set the time code-related switches for time code editing. (When editing the time code, be sure to input an external sync signal to the recorder and player.)
    - [INT/EXT] switch: Set to "INT".
    - [REC/FREE] switch: Set to "FREE".
    - [PRESET/REGEN]: Set to "PRESET".
- **Menu switch setting**
  - No. 003 <SYNC SELECT>: Set to "EXT (1)" to synchronize with an external sync signal.
  - No. 320 <PREROLL TIME>: Set the preroll time.
  - No. 328 <EDIT POINT CLEAR>: Set whether or not the edit IN point is canceled when editing is complete.
  - No. 367 <EDIT INTERRUPTION>: Set whether or not the editing operation is stopped when an error occurs in the video signal during preroll editing.
  - No. 372 <P+R AT SWAP MODE>: Set whether or not pressing the [RECORDER] and [PLAYER] buttons simultaneously is possible.
  - No. 373 <MATCH FRAME>: This setting determines whether or not the match frame function is used.
  - No. 390 <SWAP VTR SELECT>: Set according to the type of player VCR. Normally set to "AUTO".
  - No. 391 <SYNCHRONIZATION>: Switch the Bump mode ON/OFF during swap editing.
  - No. 393 <SYNC GRADE>: Select the editing accuracy during swap editing.
  - No. 395 <AUTO EE>: Set whether or not the auto EE function is used during swap editing. Set to "AUTO-EE (1)" when using only one monitor for editing.
  - No. 513 <EDIT ON SCREEN>: Selects whether or not the edit display is shown on screen during editing.

11-3 SWAP EDITING

- Use the learn function when the connected player is a non-DIGITAL S VCR. To activate the learn function, press the [RECORDER] and [SHIFT] buttons simultaneously. By using the learn function, you can reduce the number of retries in editing.

• Preparation of the recording (editing master) tape

Assemble editing

CTL signals must be recorded for a period exceeding the preroll time before the first edit IN point.

Non-recorded tape

- Record video signals such as a black picture from the built-in signal generator for a period exceeding the preroll time before the first edit IN point.
- When editing time code, record time code in the section before the first edit IN point. (e.g.) Set the time code of the first edit IN point to "00:00:00:00" and record time code for 20 seconds in the section before the edit IN point.
- Set the REC Run mode to the time code preset mode and preset the time code to "23:59:40:00".
- Record time code for 20 seconds or more.

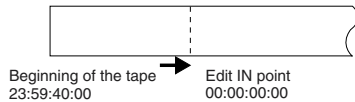

- After recording is complete, set the [REC/FREE] switch FREE.

Insert editing

CTL signals or time code data must be recorded continuously in the section for insertion.

STEP-2 editing mode selection

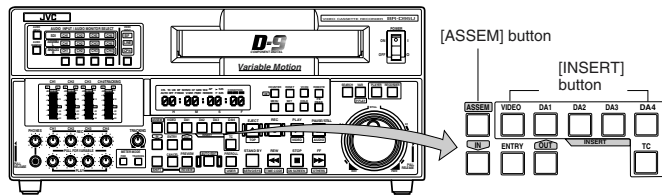

To disengage the editing mode

- Press the illuminated button again to turn off the editing mode. The button's light will go out.
- When the [ASSEM] button is illuminated, press the [INSERT] button to disengage the Assemble mode. When the [INSERT] button is illuminated, press the [ASSEM] button to disengage the Insert mode.

• Assemble editing

To execute assemble editing, press the [ASSEM] button ON beforehand. Once editing starts, ON/OFF is not possible.

• Insert editing

To execute insert editing, press the [INSERT] button(s) you want to insert (VIDEO, DA1, DA2, DA3, DA4). Even while insert editing is in progress, each button can be turned ON/OFF as required. To insert time code, set the [TC] button to ON.

11-3 SWAP EDITING

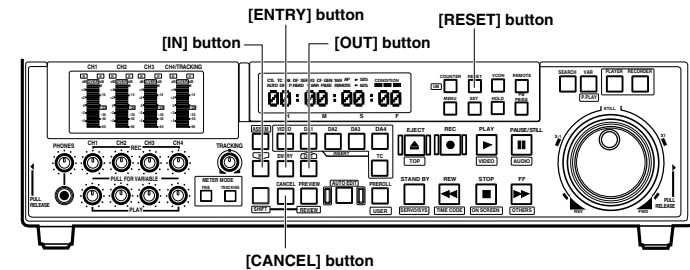

STEP-3 edit point entry

- Whenever you enter a new edit point, the previously registered edit point is automatically canceled.
- Edit points can be entered during normal VCR playback.
- If an edit IN point has not been entered, an edit IN point will be entered automatically at the point where the [AUTO EDIT] button is pressed.
- Variable playback speed during swap editing  
The recorder's variable playback speed is -1.0x to +1.0x. The player's variable playback speed is -2.0x to +3.0x.

Enter the edit IN points for the player and recorder and the edit OUT point for the player or recorder.

1. Press the [PLAYER] or [RECORDER] button to select the VCR to be operated.
2. Search the edit IN point with the search dial or jog dial.
3. Enter the edit IN point by pressing the [ENTRY] button while pressing the [IN] button.  
→ The [IN] button is illuminated and the edit IN point is entered.  
■ Enter the edit IN points for both the player and recorder.
4. Press the [PLAYER] or [RECORDER] button to select the VCR for which the edit OUT point is entered.
5. Search the edit OUT point with the search dial or jog dial and engage the Still mode.
6. Enter the edit OUT point by pressing the [ENTRY] button while pressing the [OUT] button.  
→ The [OUT] button is illuminated and the edit OUT point is entered.

■ Correcting or canceling the edit point

- Correcting the edit point
  - Turn the jog dial while pressing the [IN] and [OUT] buttons to correct the edit point in frames.
- Correct the duration.
  - Turn the jog dial while pressing the [IN] and [OUT] buttons simultaneously. Frame correction is possible.
- Canceling the edit point
  - To cancel the edit IN or OUT point  
Press the [CANCEL] button while pressing the [IN] or [OUT] button.
  - To cancel both edit IN and OUT points simultaneously  
Press the [RESET] button.
  - To cancel the player and recorder edit points as well as the audio split point: Press the [AUTO EDIT] + [CANCEL]. The selected edit modes (ASSEM, INSERT) and VAR SPEED are not canceled.

■ Checking the entered edit point/duration time (length of the edit)

- Checking the entered edit point  
To view the registered edit point on the counter display, press the [IN] or [OUT] button.  
\* If no edit point has been entered, the display will be blank (edit point is not shown).
- Checking the duration time  
Pressing the [IN] and [OUT] buttons simultaneously shows the edit duration on the counter display.

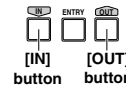

11-3 SWAP EDITING

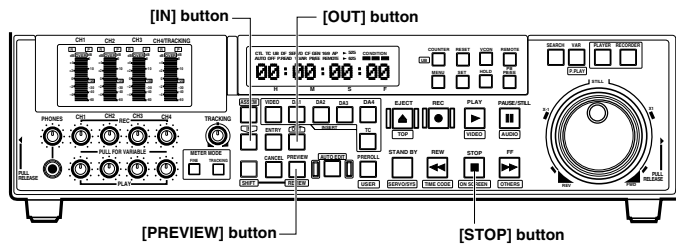

STEP-4 preview editing

- When menu switch No. 367 <EDIT INTERRUPTION> is set to "ON (1)" and an error occurs in the video signals during preroll, actual editing will not take place.
- \* If time code is discontinuous in preview, the preroll point will not be cued up in actual editing. To avoid this, the recorder enters the Stop mode after it passes the IN point in the Preview mode. (only in Assemble Editing)

[Editing screen display]  
Recorder operation mode

V=A1+A2+A3+A4+TC	R=SEL	
P=PLAY	CTL	E ■■■■■
0:01:48:00	0:00:05:00	
SPLIT IN	0:01:48:00	
OUT	0:02:31:04	
DUR. IN	0:00:00:00	
OUT	0:00:43:04	

Recorder counter display section

You can skip STEP-4 and STEP-5 and advance to STEP-6.

1. Press the [PREVIEW] button.

- The [PREVIEW] button is illuminated and both player and recorder start prerolling.
- When the player and recorder complete prerolling, they automatically enter the Play mode and start preview (rehearsal) editing. After the recorder passes the IN point, it enters the Stop mode\*. In this case, the recorder's operation mode is shown as "SEL" (Select EE) in the editing screen display.
- If the edit duration (from the IN point to the OUT point) is long and you only want to preview the edit IN point, press the [STOP] button to end preview editing.

■ Counter display in the Preview mode

A pseudo-advanced time code value is displayed on this unit and in the recorder's counter in the editing screen display. This gives the user an approximate idea of the running time. The normal on-screen display shows the time code value at the stop position. (only in Assemble Editing)

STEP-5 correcting the edit point

If correction is not necessary, skip STEP-5 and advance to STEP-6.

- If a major correction is required, enter the edit point again in STEP-3. The previously entered edit point is automatically canceled.
- If only a minor correction is required,
  1. Press the [PLAYER] or [RECORDER] button to select the VCR for correction.
  2. Turn the jog dial while pressing the [IN] or [OUT] button to correct the edit IN or OUT point in frames.

11-3 SWAP EDITING

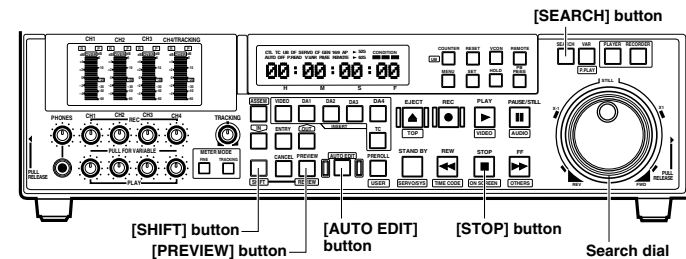

STEP-6 editing (actual)

- During insert editing, it is possible to change the channel being inserted.
- Set whether or not the edit point is automatically cleared after editing is complete with menu switch No. 328 <EDIT POINT CLEAR>

1. Press the [AUTO EDIT] button.



- ① The [AUTO EDIT] button lights and both player and recorder start prerolling.
  - ② When the player and recorder finish prerolling, both enter the Play mode automatically. When the recorder reaches the edit IN point, it automatically switches to the Record mode (actual recording starts).
  - ③ Editing ends automatically at the edit OUT point.
  - ④ When an edit has been completed, the recorder continues to run the tape for about 2 seconds (recording for assemble editing and playback for insert editing), then rewinds it automatically one frame before the edit OUT point and enters the Still mode.
- To stop editing before completion, press the [AUTO EDIT] button or press the [ENTRY] button while pressing the [OUT] button.

STEP-7 review (check)

• This step is optional.

1. Press the [PREVIEW] button while pressing the [SHIFT] button.
  - The recorder rewinds the tape automatically to the edit IN point and starts playback.
  - After the edit OUT point is passed, the tape runs for about 1 seconds and the VCR enters the Still mode.
- To cancel the review operation after it has started Press the [STOP] button.



## 11 EDITING

### 11-4 AUDIO SPLIT EDITING

This function allows you to specify the audio edit IN point independently of the video edit IN point (in ordinary editing, audio and video signals have the same edit point). This enables independent insertion of audio and video.

- Audio split editing is possible only in the Insert Edit mode.
- It is not possible to set the audio edit IN point separately for each channel (DA1/DA2/DA3/DA4).

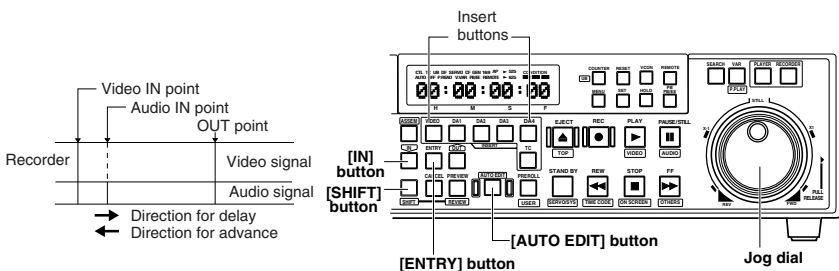

V	A1	A2	A3	A4	TC	P	STOP	R	SHTL	STIL
CTL						CTL		E	■■■■	FF
0:01:48:00	P							0:00:51:03		
SPLIT	IN	'	0:01:48:00							
	OUT	'	0:01:31:04							
DUR.	IN	'	0:00:00:00							
	OUT	'	0:00:43:04							

- Correcting the audio edit IN point

Turn the jog dial while pressing the [SHIFT] and [IN] buttons to correct the audio edit IN point in frames.

#### Procedure

- Engage the Insert Edit mode. Press the insert mode buttons ([VIDEO], [DA1], [DA2], [DA3], [DA4] buttons) as required. \* Press the [VIDEO] button and at least one of the audio channels ([DA1], [DA2], [DA3] or [DA4]).
- Enter the edit IN point for both player and recorder. The entered edit IN point is used as the edit IN point for video.
- Search the recorder's audio edit IN point with the search or jog dial operation and engage the Still mode.
- Enter the audio edit IN point by pressing the [ENTRY] button while pressing the [SHIFT] and [IN] buttons.
  - The selected audio insert button blinks, showing that the audio IN point has been entered.
- Enter the edit OUT point for the player or recorder. The edit OUT point is set at the same point for audio and video.
- Press the [AUTO EDIT] button. Editing starts automatically.

#### Disengaging the Audio Split mode

- Press the [CANCEL] button while pressing the [SHIFT] and [IN] buttons.
  - The audio insert button lights, showing that the Audio Split Edit mode has been disengaged.

## 11 EDITING

### 11-5 OTHER FUNCTION

Additional editing functions available with the BR-D95U include:

- Last edit function
- Variable-motion editing
- Motion memory function

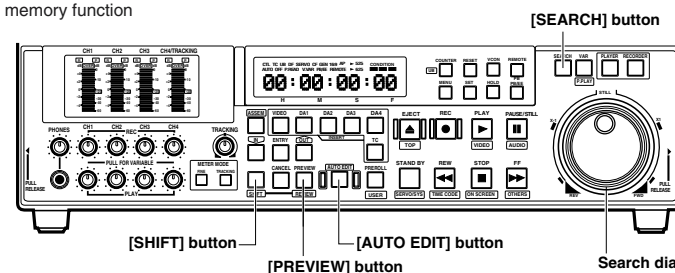

#### Variable-motion initial speed value setting

- In the Variable mode, turn the search dial to select the initial speed value.
  - The initial speed value is determined by the rotation angle of the search dial and is shown on the screen and counter display.
- Press the [SET] button to define the initial speed value.
  - After this operation, the initial speed value does not change even if the search dial is turned.
  - To change this value, press the [STOP] button to release the Variable mode, then select the initial speed value again.
  - If the [STOP] button is not pressed, the initial speed value is called when the Variable mode is engaged again after being released.

#### Last edit:

Once editing has been completed, the last edit can be recalled and executed. Press the [AUTO EDIT] button while pressing the [SHIFT] button. Each time this operation is repeated, the last edit and current edit are switched.

#### Variable-motion editing

The BR-D95U's Variable-Motion editing mode allows you to play back tapes on the player at variable speed (-2x to 3x). This is ideal for variable-motion editing and other special effects.

- **Operation:** On the recorder (BR-D95U)

- Press the [REORDER] button to set the VCR operation mode to "recorder".
- Select the recorder's editing mode (insert or assemble).
- Register the recorder's edit points.
- Press the [PLAYER] button to set the VCR operation mode to "player".
- Register the player's edit IN point.
- Press the [SEARCH] button while pressing the [SHIFT] button. The player enters the Variable mode. To release the Variable mode, press the [STOP], [FF], [REW] or [SEARCH] button. To engage the Variable mode again, execute the operation in step 6.
- Set the playback speed.
  - The player plays back the tape at the specified speed (from -2x to 3x). Speed is set by the direction and angle of the search dial rotation.
  - Press the [SET] button to register the variable-motion initial speed value. Refer to the left column.
  - The player's playback speed is shown on the recorder's counter display in percentages (e.g. -200%: -2x, 300%: 3x). Playback speed can also be determined automatically by setting all four edit points.
- Press the [AUTO EDIT] button to start editing.

#### Notes:

- Use the variable speed value for the player shown on the BR-D95U's counter display as a guide. Actual playback speed depends on the player.
- Use a variable speed within the range -1x through 1x. When the BR-D95U is used as a player, out-of-range variable speed will distort the picture and/or sound.

11-5 OTHER FUNCTION

(Editing screen)

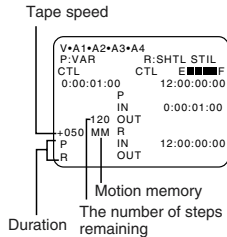

- When 128 steps are stored in the motion memory, the [PREVIEW] button stops blinking and lights steadily.
- Use the variable speed value for the player shown on the BR-D95U's counter display as a guide. Actual playback speed depends on the player.

■ Motion memory function

The motion memory function allows you to manually store the player's playback speed data in memory. You can call up this data later for variable-motion editing.

- **Operation** : on the recorder (BR-D95U)
  1. Register the edit IN points for the recorder and player (do not register the edit OUT point for the player).
  2. Press the [PLAYER] button to set the VCR operation mode to "player".
  3. Press the [SEARCH] button while pressing the [SHIFT] button to engage the Variable mode. Press the [SET] button to register the variable-motion initial speed value. Refer to the "Variable-motion initial speed value setting" in the margin on the previous page.
  4. Set the playback speed (first speed) to be stored in the motion memory by turning the search dial.
  5. Press the [PREVIEW] button to reproduce the motion memory data and turn the search dial to control the playback speed. After the edit IN point, the playback speed set by the angle of the search dial rotation is stored in memory.
    - Up to 128 steps can be stored in the motion memory. The number of steps remaining is shown on the editing screen.
    - When the motion memory function is activated, "MM" is shown on the editing screen. As long as MM data is stored in memory, the [PREVIEW] button will blink.
  6. Register the edit OUT point to end the motion memory setting.
    - To store the speed in memory again, press the [PREVIEW] button. The edit OUT point is automatically canceled.
    - To check the stored data, press the [PREVIEW] button while pressing the [SHIFT] button (Motion preview).
  7. Press the [AUTO EDIT] button to start editing. If playback speed has not been stored in the motion memory, turning the search dial during editing also controls the playback speed. However, speed data cannot be stored in memory during editing.

11-6 MANUAL EDITING

When editing with a camera or a VCR (player) without an RS-422 serial remote connector, use the BR-D95U's [AUTO EDIT] and [PREROLL] buttons for editing.

- Use the BR-D95U as the recorder.
  1. Select assemble or insert editing with the edit mode select buttons.
    - For insert editing, select the signal to be edited.
  2. Search the edit IN point with the search and jog dials on the recorder and engage the Still mode.
  3. Input the signal from the player or camera.
  4. Press the recorder's [AUTO EDIT] button.
    - The recorder prerolls and starts the editing operation.
    - Recording starts automatically at the edit IN point.
  5. To stop editing, press the recorder's [AUTO EDIT] button.
    - The recorder enters the Still mode. The edit OUT point is automatically entered as the edit IN point for the next edit.
  6. Repeat steps 1 to 5 to continue editing.

11-7 EDITING WITH THE PRE-READ FUNCTION

The pre-read function makes it easy to add A/B roll editing-style wipes and fades even when using only one player. Pre-read works by reading out the image or sound at the recording start position just before recording starts during editing. Special effects or mixer can then be added to the read-out picture or sound which is then recorded at its original position together with the incoming material. And because both sources (the player and recorder) can handle moving pictures, you'll be able to achieve smooth, natural and professional looking special editing effects. Pre-read can be used with both video and audio signals.

Feature Comparison of Pre-Read with Conventional A/B Roll Editing.

	Conventional A/B roll editing system	Pre-read A/B roll editing system
Configuration		
Source material	Source material is on two tapes. One tape is played back by each player.	Source material is obtained from the player's playback picture and the pre-read picture. Material from the recorder can be obtained automatically.
Picture with effects	Moving picture and sound (two players)	Moving picture and sound (picture from one player and pre-read picture from the recorder)
Editing operation	Edit point settings required for two players and one recorder.	Edit point settings required for one player and one recorder.
Wipe and mix effects, etc.		

■ Setting the pre-read function...Set before making the pre-read connection.

- BR-D95U menu switch No. 351 <PREREAD>  
Set menu switch No. 351 <PREREAD> to "OFF" when using an editing controller with pre-read capability. Set menu switch No. 351 <PREREAD> to "ON" when using an editing controller with no pre-read capability. This menu switch can be switched ON/OFF independently for video and audio.
- When audio pre-read is performed, it is recommended to use the [AUDIO REC] volume knobs preset position because audio level for recording cannot be checked.
- Setting the audio output phase for audio pre-read  
Use <AUDIO PHASE> in the audio control menu to adjust the audio output phase to correspond with the video output phase (see page 118).
- Correcting audio output phase delay during audio pre-read  
To correct audio output timing, set menu switch No. 352 <AUD PREREAD TIMING> to "OFF SET". Correction is performed by detecting the delay of the external video device based on the delay set with <AUDIO PHASE> in the audio control menu.

Cautions

- Before the pre-read menu switch setting is released, be sure to disconnect the units for pre-read editing. Otherwise, a loop occurs in the connection cables, causing excessive sound volume and distortion which may damage the connected equipment.
- It is not possible to rewrite sub time code data when the pre-read function is used.

## 11 EDITING

### 11-7 EDITING WITH THE PRE-READ FUNCTION

#### Example of editing system configuration

An example of a pre-read editing system is shown below.

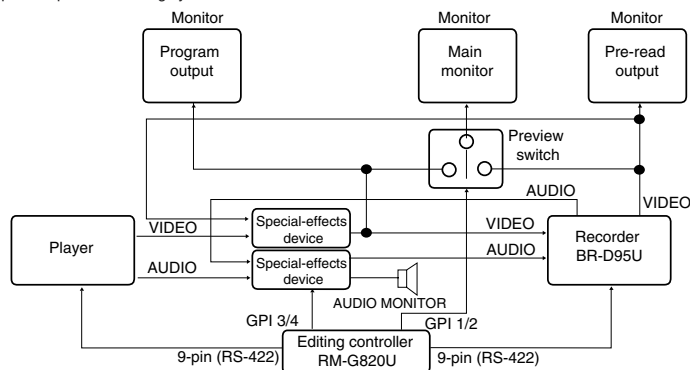

- Preview switcher  
Automatically switches the signal shown on the main monitor in conjunction with editing controller operation. (e.g. SW-320 from Imeginics Co., Ltd.)
- Enables editing without separate monitors for program output and pre-read output.
- When using an editing controller provided with the pre-read function, is not necessary to set menu switch No. 351 <PRE READ> on the BR-D95U to "OFF".  
Usable controller: RM-G820U
- When using the RM-G820U, check that the model name shown on its packing case ends with (A) and that (A) is indicated on the serial number plate on the controller.
- The RM-G820U is not ready for audio insert editing on CH3 and CH4. To select insertion on CH3 and CH4 with this unit, change the settings of menu switch No. 377 <AUD EDIT PRESET CH3> and No. 378 <AUD EDIT PRESET CH4>.

Positions indicating (A)



Upgrading is required if the RM-G820U without (A) indication is used.

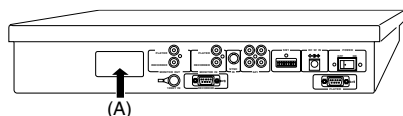

#### Notes:

- Note on the special effects generator  
As most special effects generators provided with a DVE (Digital Video Effect) function have a built-in frame memory, one frame delay occurs if the pre-read function of the BR-D95U is used. To avoid this, only use special effects generators with no frame memory (such as JVC's KM-3000) or ones provided with a function that allows you to bypass the frame memory.
- When menu switch No.351 <PRE READ> is set to "VID-ON" or "AUD-ON", the Record mode cannot be engaged (pressing both the [REC] and [PLAY] buttons has no effect).
- When editing with the pre-read function, the material on the tape in the recorder is replaced with the special-effects pictures. If you want to keep the original material, be sure to back up the original tape.
- When video phase shifting is obvious in video signals inserted for pre-read editing, adjust the video phase (refer to page 120).
- If the editing controller is not provided with the pre-read function, set menu switch No. 351 <PRE READ> of the recorder BR-D95U to "ON".

## 12 EDITING SYSTEM PHASE ADJUSTMENT

To ensure accurate, error-free editing with an AB roll editing system or any other multiple-unit system, you must adjust the phase of the built-in time base corrector (TBC) after connecting all system components. Phase adjustment must be updated each time you replace a connection cable, add or replace one of the units, or make any other changes.

### 12-1 CONNECTION

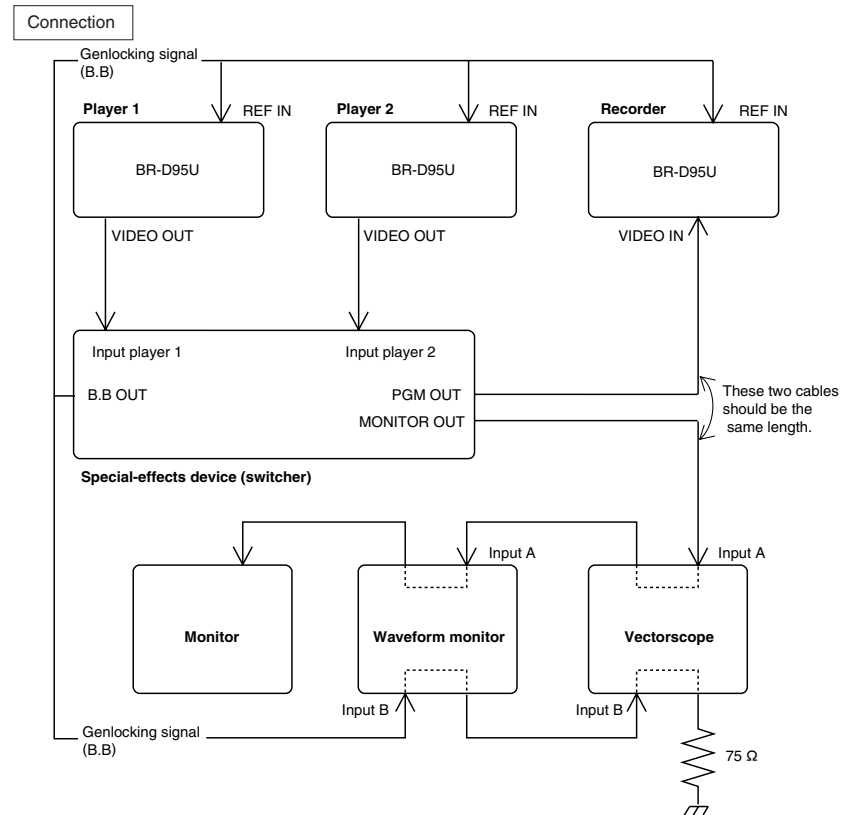

- ① Send external reference sync signals from the sync signal generator to the system components.
- ② Composite video signals are delivered as video signals.

\* When editing on directly connected VCRs without a switcher, adjustment of system and subcarrier phases is not necessary.

## 12 EDITING SYSTEM PHASE ADJUSTMENT

### 12-2 ADJUSTMENT

Adjust the items shown on the counter or on screen display by pressing the front panel [VCON] button.

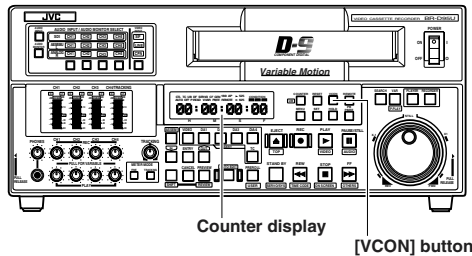

#### Adjustment items

Adjustment items displayed on screen or on the unit's display are listed in the table below.

● Video control menu (page 1 on screen)

○: Possible X: Impossible

Display		Adjustment contents	Adjustment value	Video signals			Operation		
On screen display	Counter display			LINE	CPN	SDI	Main unit	TBC remote control	9-pin
VIDEO GAIN	Vgain	Output video level	-128 to +64	○	○	○	○	○	○
CHROMA GAIN	Cgain	Output chroma level	-128 to +64	○	○	○	○	○	○
CHROMA PHASE	Cphas	Output chroma phase	-128 to +127	○	○	○	○	○	○
SETUP LEVEL	Setup	Output setup level	-128 to +127	○	○	○	○	○	○
VID (H) PHASE	Hphas	Output video (horizontal) phase	-128 to +127	○	○	○	○	X	○
VID (V) PHASE	Vphas	Output video (vertical) phase	-5 to +5	○	○	○	○	X	X
SYSTEM PHASE	Sphas	Output system phase	-64 to +64	○	○	○	○	○	○
SC	SCph	Output SC phase	0 to 511	○	○	○	○	○	○
SCH	SCHph	Output SCH phase	0 to 255	○	X	X	○	X	X
VIDEO ALL UNITY	Vunity	Standard setting ON/OFF	ON/OFF						
VIDEO REMOTE	Vrem	External video controller ON/OFF	ON/OFF						

● Audio control menu (page 2 on screen)

Display		Adjustment contents	Adjustment value	Audio signals			Operation		
On screen	Counter display			ANALOG	AES/EBU	SDI	Main unit	TBC remote control	9-pin
AUDIO PHASE	Aphas	Output audio phase	-480 to +720	○	○	○	○	X	X

On screen (page 1)

```
<VIDEO CONTROL MENU> 1/2
▷VIDEO GAIN 000
CHROMA GAIN 000
CHROMA PHASE 000
SETUP LEVEL 000
VID (H) PHASE 000
VID (V) PHASE 0
SYSTEM PHASE 00
SC PHASE 000
SCH PHASE 000
VIDEO ALL UNITY OFF
VIDEO REMOTE OFF
```

On screen (page 2)

```
<AUDIO CONTROL MENU> 2/2
▷AUDIO PHASE +000
```

Counter display

```
Vgain +000
Adjustment item Adjustment value
```

\* Set the output timing for the analog/digital audio playback signal. Settings below 00 advance the output timing, while settings above 00 delay the output timing. (1 sample: approx. 20 μs)

## 12 EDITING SYSTEM PHASE ADJUSTMENT

### 12-2 ADJUSTMENT

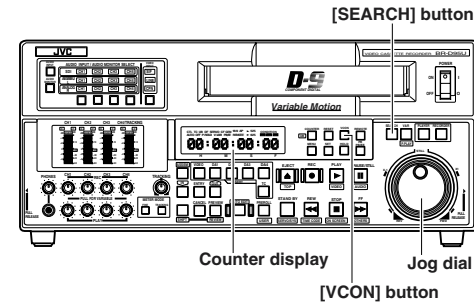

On screen display

```
<VIDEO CONTROL MENU> 1/2
▷VIDEO GAIN 000
CHROMA GAIN 000
CHROMA PHASE 000
SETUP LEVEL 000
VID (H) PHASE 000
VID (V) PHASE 0
SYSTEM PHASE 00
SC PHASE 000
SCH PHASE 000
VIDEO ALL UNITY OFF
VIDEO REMOTE OFF
```

- For individual adjustment, set "VIDEO ALL UNITY" to "off".
- To make adjustments with the optional TBC remote control unit connected to the rear panel [VIDEO CONTROL] connector, be sure to set "VIDEO REMOTE" to "ON".
- YC dealy volume of the TBC remote control(BVR-50) is unavailable.
- You can select the output chroma phase reference signal with menu switch No. 124 <CHROMA ROTE> (component or composite signals).

#### Adjustment

This section describes the procedure for adjusting video setting value on the operation panel.

1. Press the [VCON] button to display the adjustment items on the counter display.
2. Select the adjustment item by turning the jog dial.
  - Adjustment items are shown on the counter display or on screen.
3. Adjust the value by turning the jog dial while pressing the [SEARCH] button.
  - The adjustment items on screen can be selected with the cursor.
  - When making an adjustment, refer to an actual signal waveform as shown in the "Adjustment outline for each item" below.
4. Repeat steps 2 to 3 to adjust other items.
5. Press the [SET] or [VCON] button to finish.
  - The normal counter display is restored.
  - To reset all video parameters to the default settings, set the adjustment item "VIDEO ALL UNITY" to "ON".
  - To independently set items in the Unity mode, select the desired item and press the [RESET] button. Only the selected item is set to the standard value.

## 12 EDITING SYSTEM PHASE ADJUSTMENT

### 12-2 ADJUSTMENT

#### Adjustment outline for each item

- Video level/setup level/chroma level/chroma phase  
Use menu switch No. 124 <CHROMA ROTE> to specify whether the chroma phase reference signal is a composite signal or component signal.
1. **Play back a cassette tape with standard color signals recorded on it.**  
Do not use the built-in color bar signal for adjustment.
  2. **Adjust the knobs so that the displays on the waveform monitor (WFM) and the vectorscope (VSC) appear as illustrated below.**

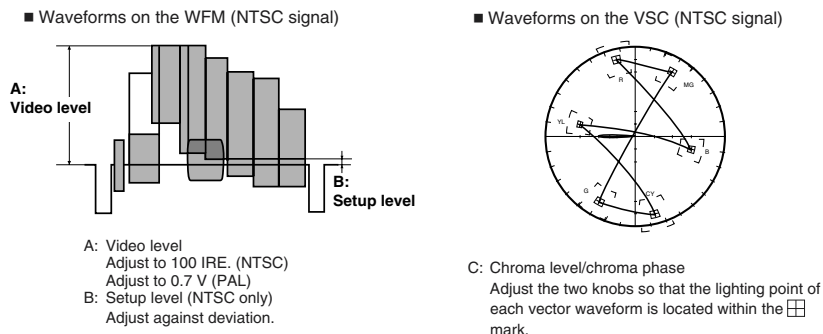

#### Video (H) phase (VID (H) PHASE) adjustment

The video phase determines where a picture is located with respect to the sync signal. You can adjust this using the same waveform monitor used for system phase adjustment. Set the WFM reference sync to INT and adjust while observing blanking until no part of the VCR picture is missing in the rising section. If you're not using a waveform monitor, wipe the picture with the switcher reference signal and adjust until the entire picture can be seen on the monitor.

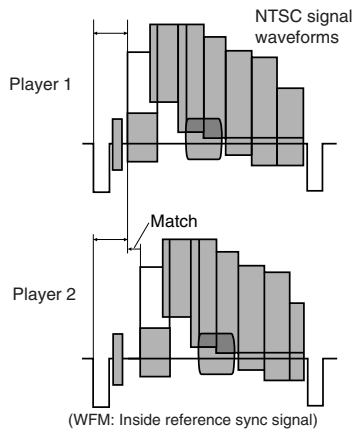

#### Adjustment of Player 1

1. Select Player 1 with the special-effects device (switcher).
2. Play back the reference color bar on Player 1.
3. Set the WFM's input to A and synchronize with input A. Adjust the video phase by setting the [VID (H) PHASE] item of Player 1 so that none of the image is missing. (Refer to the upper figure on the left.)

#### Adjustment of Player 2

4. Select Player 2 with the special-effects device (switcher).
5. With the WFM's input set to A and input A synchronized, adjust the video phase by setting the [VID (H) PHASE] item of Player 2 in the same way as step 3. (Refer to the lower figure on the left.)

## 12 EDITING SYSTEM PHASE ADJUSTMENT

### 12-2 ADJUSTMENT

#### System phase/subcarrier phase/SCH phase

- The system phase can be varied with the subcarrier-unit step. The relationship between the sync and burst phase does not change.
- The phase in the subcarrier can be varied. The relationship between the sync and burst phase does not change.
- To adjust the phase with reference to sync phase, follow the system phase adjustment procedure described below.
  - To adjust the phase with reference to subcarrier phase, adjust the system phase as described below, then adjust the subcarrier phase.
  - To vary sync and burst phase (SCH), adjust it with <SCH PHASE> in the video control menu.

#### System phase (SYSTEM PHASE) adjustment

System phase adjustment matches the VCR's blanking phase with the switcher's correct blanking phase. Switch between the switcher reference signal and the input VCR signal and adjust until there is no change in phase position. Without this adjustment, video distortion occurs after completion of fading during switching.

#### Waveforms on a waveform monitor

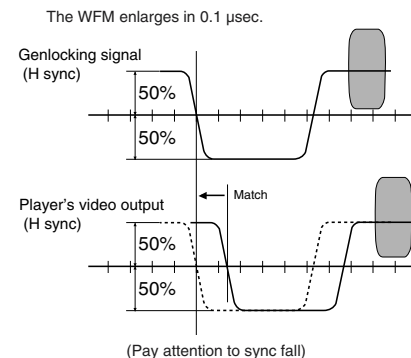

#### Phase setting for genlocking signal

1. Set the waveform monitor (WFM)'s input to B and synchronize with input B. Set the H sync position with the WFM's H POSITION volume control to 50% of the H sync level. (Refer to the upper figure on the left.)

#### Adjustment of Player 1

2. Select Player 1 with the special-effects device (switcher).
3. Play back the reference color bar on Player 1.
4. Set the WFM's input to A and synchronize with input B. Set the [SYSTEM PHASE] item of Player 1 to the same H sync position as step 1. (Refer to the lower figure on the left.)

#### Adjustment of Player 2

5. Select Player 2 with the special-effect device (switcher).
6. Repeat steps 3 and 4 to adjust the system phase of Player 2.

- The KM-D600 switcher is self-adjusting. No adjustment is required.

#### Subcarrier phase (SC PHASE) adjustment

System subcarrier phase adjustment matches the VCR subcarrier with the reference subcarrier of the switcher. Adjust so that the reference subcarrier overlaps the VCR subcarrier.

#### Waveforms on the vector scope (NTSC signal)

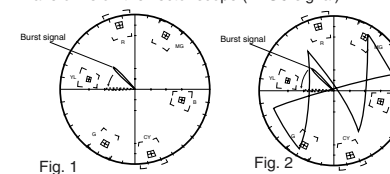

- Adjustment of the KM-D600 switcher is not necessary as it is self-adjusting.
- Adjustment of the KM-3000 switcher is not necessary as it is a component switcher.
- Composite switchers other than the KM-D600 must be adjusted.

#### Phase setting for genlocking signal

1. Set the vector scope's input to B and synchronize with input B. Adjust the phase of the burst signal to the reference line with the vector scope (Refer to Fig. 2 on the left.)

#### Adjustment of Player 1

2. Select Player 1 with the special-effects device (switcher).
3. Play back the reference color bar on Player 1.
4. Set the vector scope's input to A and synchronize with input B. Adjust the phase of a burst signal to the reference line by setting the [SC PHASE] item of Player 1. (Refer to Fig. 2 on the left.)

#### Adjustment of Player 2

5. Select Player 2 with the special-effects device (switcher).
6. Repeat steps 3 and 4 to adjust the subcarrier of Player 2.

## 12 EDITING SYSTEM PHASE ADJUSTMENT

### 12-3 DUBBING LOOP FUNCTION

The dubbing loop function allows you to effectively perform analog video signal adjustment.

The dubbing loop function loops video signals and generates color bar signals from the built-in signal generator. The picture passes through the looped video signal circuit and is fed back and stored in the memory circuit. Then, instead of outputting color bar signals from the signal generator, the picture stored in memory is output and passed through the looped video signal circuit the designated number of times. The same effect is obtained each time this pseudo-dubbing is repeated and the video signal can be adjusted according to the picture output.

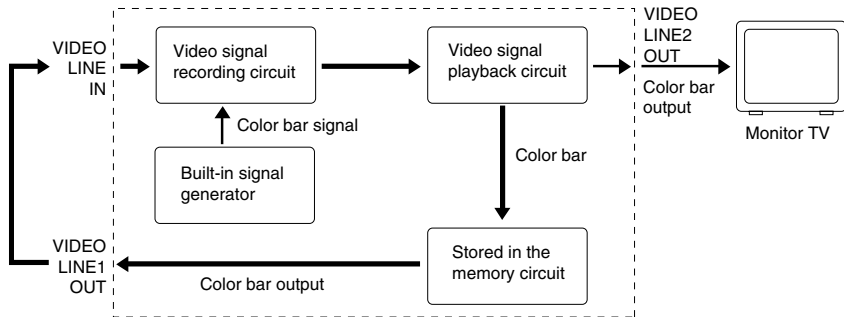

#### Note

- For the dubbing loop function, use the composite video signal.

- Connect the rear panel's video input connector and video output connector with the cable.
- Set menu switch No. 620 <DUBBING LOOP> to activate the dubbing loop function.
  - OFF (0) : The dubbing loop function is disabled.
  - 3 TIMES (1) : The dubbing loop function repeats 3 times.
  - 5 TIMES (2) : The dubbing loop function repeats 5 times.
  - 10 TIMES (3) : The dubbing loop function repeats 10 times.
  - When the menu switch is set to any position except OFF (0), the Dubbing Loop mode is activated.
- While referring to the color bar on the monitor, adjust the video control parameters so that color changes in the picture are minimized.
- To end the dubbing loop mode, set menu switch No. 620 <DUBBING LOOP> to "OFF (0)" and press the [SET] button. Normal operation is restored.

## 13 RS-232C protocol

### 13-1 Command tables

BASIC TABLE

	0	1	2	3	4	5	6	7	8	9	A	B	C	D	E	F
0					Enter	In Entry					Standby On		Auto Edit		TC Preset	
1	Complete				ClearError	Out Entry					Standby Off		Preview		UB Preset	
2	Error				CueUp with Data	In Flag Reset		Rom Version			Preroll	CueUp with Data	Review		CTL Data Reset	
3	Cassette Out					Out Flag Reset					Eject				In Data Preset	
4	Not Target					In Flag Recall							Full Ee On		Out Data Preset	
5						Out Flag Recall					Variable Fwd	Fwd Shuttle	Ee off		Edit Preset	
6					In Shift(+)	Clear					Variable Rev	Rev Shuttle		Preroll Time Sense	Preroll Time Preset	JVC-1 Table Select
7					In Shift(-)									Status Sense	Timer Mode Select	Basic Table Select
8					Out Shift(+)	Go to In							Select Ee On	TC Data Sense		
9					Out Shift(-)	Goto Out							Ee off	CTL Data Sense	Edit Preset (4ch)	
A	ACK		Play	RevShuttle X1	Memory								Rec	In Data Sense	Rec Request	
B	NAK		FwdShuttle X4	RevShuttle X4	Memory Search					FI		Rec Pause	Out Data Sense	TimeCode Switch Preset	VTR Ind.	
C			FwdShuttle X0.99	RevShuttle X0.99						Rew			UB Data Sense			
D			FwdShuttle Still	RevShuttle Still									JVC Status Sense	Memory Switch Preset		
E			FwdShuttle X6	RevShuttle X6									Edit On	SubTC Data Sense		
F			Stop	Still									Edit Off	SubUB Data Sense		

JVC-1 TABLE

	0	1	2	3	4	5	6	7	8	9	A	B	C	D	E	F
0					Enter	In Entry					Standby On					
1	Complete				ClearError	Out Entry					Standby Off			Device Type Request		
2	Error					In Flag Reset		Rom Version			Preroll	Play after CueUp with Data			CTL Data Reset	
3	Cassette Out					Out Flag Reset					Eject			Memory Switch Sense	In Data Preset	
4	Not Target					In Flag Recall							Full Ee On	Tape Remain Sense	Out Data Preset	
5						Out Flag Recall					Variable Fwd	Fwd Shuttle	Ee off			
6					In Shift(+)	Clear					Variable Rev	Rev Shuttle				JVC-1 Table Select
7					In Shift(-)									Status Sense	Timer Mode Select	Basic Table Select
8					Out Shift(+)	Go to In								TC Data Sense	Analog Data Select	
9					Out Shift(-)	Goto Out								CTL Data Sense		
A	ACK		Play	Memory									Rec		Rec Request	
B	NAK			Memory Search						FI		Rec Pause	Panel Switch Sense	Panel Switch Set	VTR Ind.	
C										Rew				JVC Status Sense	Memory Switch Preset	
D																
E																
F			Stop	Still												

13-2 RS-232C Commands

■ RS-232C specifications  
9PIN D-SUB



PIN No.	Signal	Operation	Direction
2	RxD	Reception data	VCR ← CPU
3	TxD	Transmission data	VCR → CPU
4	DTR	Data terminal ready	VCR → CPU
5	GND	Signal ground	
6	DSR	Data set ready	VCR ← CPU

Note: CPU means a controller such as a personal computer.

Mode : Non-synchronized  
 Character length : 8 bits  
 Parity check : None  
 Start bit : 1  
 Stop bit : 1  
 Data rate : 9600 bps  
 Bit construction

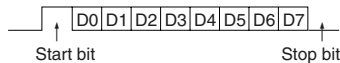

■ Basic format

(1) The VCR returns [0A: ACK]-[0B: NAK]-[02:Error] in response to each byte sent from the controller.  
 Eg.: E5: EditPreset

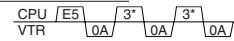

CPU: Controller such as a personal computer  
 VCR: BR-D95 series

- In response to the first byte sent from the controller, the VCR returns either [ACK], [NAK] or [Error] within 100 μs.
- The controller confirms the reply from the VCR and then outputs the second byte. The VCR returns either [ACK], [NAK] or [Error] within 100 μs.
- The controller confirms the reply from the VCR and then outputs the third byte. The VCR returns either [ACK], [NAK] or [Error] within 100 μs.

(2) When the data is recognized by the controller, the VCR returns the standard byte data.  
 Eg.: D7: StatusSense



CPU: Controller such as a personal computer  
 VCR: BR-D95 series

- The VCR starts to output data within 100 μs after receiving the first byte from the controller. Stop bits are inserted between output data.

■ Receiving

- The VCR always receives commands from the controller. The VCR also replies to all “sense” commands such as StatusSense/TimeSense.
- Switch Remote/Local on this unit to “Remote”.

■ Time management

- Command output timing is managed as follows:
- The minimum command interval is 10 ms.
  - The minimum byte interval is 100 μs when the controller outputs the next byte without confirming the [ACK], [NAK] or [Error] returned from the VCR.

■ Processing method when an error occurs

- When NAK (0B) is returned  
 The first byte command that the VCR was unable to receive is sent. Output another command.
- When Error (02) is returned <The Error section of StatusSense (bit-0 of the first byte) describes the Error mode.>
  - The VCR receives an illegal command for the second byte and later. With ClearError [41], the previous byte is canceled.
  - When ClearError [41] is transmitted repeatedly because Error [02] is returned more than once, ACK [0A] is returned to release the Error mode. The Error mode can also be released by canceling the commands being input with Clear [56].
- If ACK [0A], NAK [0B], Error [02] or Data is not returned  
 The VCR does not recognize the byte. Cancel the commands being input with Clear [56] and transmit the command again.  
 (The VCR replies within 1 ms after receiving the command from the controller.)
- When NotTarget [05] is returned  
 The target point on the tape specified with CueUpWith Data/Preroll does not exist. Input a different value and try again.

13-2 RS-232C Commands

■ Return command from the VCR

**01: Completion** Basic/JVC-1 Table  
 The VCR outputs this command after completing the requested operation (CueUp With Data/Preroll/AutoEdit, etc.).

**02: Error** Basic/JVC-1 Table  
 The VCR outputs this command when invalid data is received. Bit-0 (Error) of the first byte is set for [D7: StatusSense].  
 In this condition, the VCR will not accept any command except the StatusSense command. The Error mode can be released with [41: ClearError] or [56: Clear].  
 To cancel the entire command, use [56: Clear]. To cancel only the most recently transmitted data, use [41: ClearError].

**03: Cassette Out** Basic/JVC-1 Table  
 The VCR outputs this command when the eject operation is complete.

**05: Not Target** Basic/JVC-1 Table  
 The VCR outputs this command when CueUp With Data/Preroll operation cannot be completed normally.

**0A: ACK** Basic/JVC-1 Table  
 This command is returned when the defined command is received.

**0B: NAK** Basic/JVC-1 Table  
 This command is returned when an undefined or invalid command is received.

**ASCII code** Basic/JVC-1 Table  
 Alphanumeric equivalents for certain “Sense” commands.

30: Zero	61: a	6B: k	75: u
31: 1	62: b	6C: l	76: v
32: 2	63: c	6D: m	77: w
33: 3	64: d	6E: n	78: x
34: 4	65: e	6F: o	79: y
35: 5	66: f	70: p	7A: z
36: 6	67: g	71: q	20: Space
37: 7	68: h	72: r	2D: -
38: 8	69: i	73: s	_____
39: 9	6A: j	74: t	_____

■ Auxiliary commands to the VCR

**40: Enter** Basic/JVC-1 Table  
 If this command is transmitted during data transmission, data transmitted after this command will be zero (=30) or space (=20). More information on how to use this command can be found in the descriptions of related commands where its use is valid.

**41: Clear Error** Basic/JVC-1 Table  
 In the Error mode, this command cancels the last numeric/data command.  
 The Error mode is engaged when bit-0 (Error) of the first byte in D7: StatusSense is “1”.

**56: Clear** Basic/JVC-1 Table  
 In the Error mode, this command releases the command.

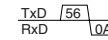

The Error mode is engaged when bit-0 (Error) of the first byte in D7: StatusSense is “1”.

**ASCII code** Basic/JVC-1 Table  
 Alphanumeric equivalents for certain Preset commands.

30: Zero	61: a	6B: k	75: u
31: 1	62: b	6C: l	76: v
32: 2	63: c	6D: m	77: w
33: 3	64: d	6E: n	78: x
34: 4	65: e	6F: o	79: y
35: 5	66: f	70: p	7A: z
36: 6	67: g	71: q	20: Space
37: 7	68: h	72: r	2D: -
38: 8	69: i	73: s	_____
39: 9	6A: j	74: t	_____

■ Corresponding commands

**3A: Play Key** Basic/JVC-1 Table  
 Playback

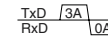

**3B: Fwd-4 Key** Basic Table  
 4x playback in the forward direction

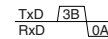

**3C: Fwd-0.09 Key** Basic Table  
 0.09x playback in the forward direction

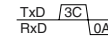

**3D: Fwd Still Key** Basic Table  
 Still playback

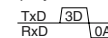

**3E: Fwd-6 Key** Basic Table  
 6x playback in the forward direction

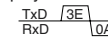

13-2 RS-232C Commands

**3F: Stop Key** **Basic/JVC-1 Table**  
Stop

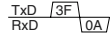

**42: CueUp With Data** **Basic Table**  
Execute CueUp to the desired point on the tape. The same as B2: CueUpWithData.  
 • The VCR returns [01: Complete] after CueUp is complete.  
 • When the specified point is not on the tape, the VCR returns [05: NotTarget].

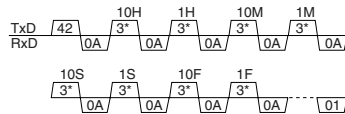

- Input values of 0 to 9 which follow the second byte of TxD are expressed with ASCII code.
- Auxiliary commands**
- [56: Clear] is valid for the second TxD byte or later. All commands back to the first byte are cleared.
- When [02: Error] occurs, [41: ClearError] is valid. The previous command (one byte) is cleared.
- [40: Enter] is valid for the second TxD byte or later. Whatever has not yet been specified is regarded as [30: Zero].

**4A: Rev-1 Key** **Basic Table**  
1x playback in the reverse direction

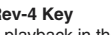

**4B: Rev-4 Key** **Basic Table**  
4x playback in the reverse direction

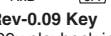

**4C: Rev-0.09 Key** **Basic Table**  
0.09x playback in the reverse direction

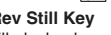

**4D: Rev Still Key** **Basic Table**  
Still playback



**4E: Rev-6 Key** **Basic Table**  
6x playback in the reverse direction

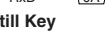

**4F: Still Key** **Basic/JVC-1 Table**  
Still playback



**50: In Entry** **Basic/JVC-1 Table**  
Registers the current time as IN point.

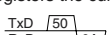

**51: Out Entry** **Basic/JVC-1 Table**  
Registers the current time as OUT point.

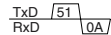

**52: In Flag Reset** **Basic/JVC-1 Table**  
Disables the registered IN point.

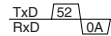

**53: Out Flag Reset** **Basic/JVC-1 Table**  
Disables the registered OUT point.

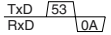

**54: In Flag Recall** **Basic/JVC-1 Table**  
Enables the disabled IN point.

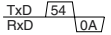

**55: Out Flag Recall** **Basic/JVC-1 Table**  
Enables the disabled OUT point.

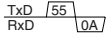

**58: Go-To In** **Basic/JVC-1 Table**  
Executes CueUp to the point registered on the tape with [50: In Entry] and [E3: In Data Preset].  
 • The VCR returns [01: Complete] when CueUp is complete.  
 • When the specified point is not on the tape, the VCR returns [05: NotTarget].  
 • When the IN point is not registered, the VCR returns [0B: NAK].

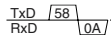

**59: Go-To Out** **Basic/JVC-1 Table**  
Executes CueUp to the point registered on the tape with [51: Out Entry] and [E4: Out Data Preset].  
 • The VCR returns [01: Complete] when CueUp is complete.  
 • When the specified point is not on the tape, the VCR returns [05: NotTarget].  
 • When the IN point is not registered, the VCR returns [0B: NAK].

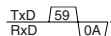

**5A: Memory** **Basic/JVC-1 Table**  
Registers the current time as the Memory point.

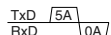

**5B: Memory Search** **Basic/JVC-1 Table**  
Executes CueUp to the point registered on the tape with [5A: Memory].  
 • The VCR returns [01: Complete] when CueUp is complete.  
 • When the specified point is not on the tape, the VCR returns [05: NotTarget].  
 • When the Memory point is not registered, the VCR returns [0B: NAK].

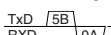

13-2 RS-232C Commands

**72: ROM version** **JVC-1 Table**  
Returns the CPU (ROM)'s program version.

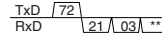

- The first byte is fixed at 21.
- The second byte shows the type of software (D9 = "03").
- The third byte shows version information.

**A0: Standby On Key** **Basic/JVC-1 Table**  
Standby On



**A1: Standby Off Key** **Basic/JVC-1 Table**  
Standby Off



**A2: Preroll Key** **Basic/JVC-1 Table**  
Rewinds the tape for the preroll time.

- The preroll time is specified by [E6: Preroll Time Preset].
- When it is not specified, the VCR's menu setting is used.
- The VCR returns [01: Complete] after preroll is complete.

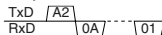

**A3: Eject Key** **Basic/JVC-1 Table**  
Eject



- When the Eject operation is completed properly, the VCR returns [03: Cassette Out].

**A5: Variable Fwd Key** **Basic/JVC-1 Table**  
Variable playback in the forward direction. Specify the speed with the second byte of TxD. Refer to the speed/data correspondence table. (See page 134.)

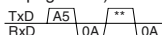

- Auxiliary commands**
- Clearing with [56: Clear] and [41: ClearError] has no effect.
- [40: Enter] has no effect.

**A6: Variable Rev Key** **Basic/JVC-1 Table**  
Variable playback in the reverse direction. Specify the speed with the second byte of TxD. Refer to the speed/data correspondence table.

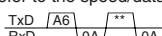

- Auxiliary commands**
- Clearing with [56: Clear] and [41: ClearError] has no effect.
- [40: Enter] has no effect.

**AB:FF Key** **Basic/JVC-1 Table**  
Fast-forwarding.

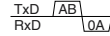

**AC: Rew Key** **Basic/JVC-1 Table**  
Rewinding.

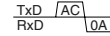

**B2: CueUp With Data** **Basic/JVC-1 Table**  
Executes CueUp to the desired point on the tape. Same as 42: CueUpWithData. (Basic only)  
 • The VCR returns [01: Complete] after CueUp is complete.  
 • When the specified point is not on the tape, the VCR returns [05: NotTarget].

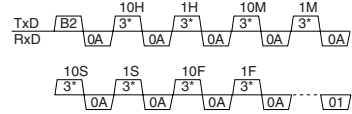

- Input values of 0 to 9 which follow the second byte of TxD are expressed with ASCII code.
- Auxiliary commands**
- [56: Clear] is valid for the second byte or later of TxD. All commands back to the first byte are cleared.
- When [02: Error] occurs, [41: ClearError] is valid. The previous command (one byte) is cleared.
- [40: Enter] is valid for the second TxD byte or later. Whatever has not yet been specified is regarded as [30: Zero].

**B2: Play after CueUp With Data** **JVC-1 Table**  
Executes CueUp and engages the Play mode. The VCR returns [01: Complete] after CueUp is complete.

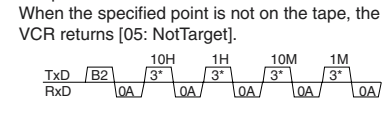

- When the specified point is not on the tape, the VCR returns [05: NotTarget].
- Input values of 0 to 9 which follow the second byte of TxD are expressed with ASCII code.
- Auxiliary commands**
- [56: Clear] is valid for the second TxD byte or later. All commands back to the first byte are cleared.
- When [02: Error] occurs, [41: ClearError] is valid. The previous command (one byte) is cleared.
- [40: Enter] is valid for the second TxD byte or later. Whatever has not yet been specified is regarded as [30: Zero].



13-2 RS-232C Commands

**B5: Fwd Shuttle Key** **Basic/JVC-1 Table**

Shuttle search playback in the forward direction.

- Specify the Fwd Shuttle Mode. The speed is specified by the second byte.
- Specify the adjustment speed.

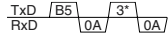

- The second TxD byte consists of numeric data and is expressed with "30", "31", "32" ... "38", "39", "3A", "3B" and "3C".
- When invalid data is received, the VCR returns "02: Error".
- The speeds corresponding to each value are shown below.

Data	30	31	32	33	34	35	36	37	38
Speed	Still	0.03	0.09	0.20	0.50	1	2	4	6

39	3A
10	17 or 32

Data		3B	3C
Adjustment speed		-10%	+10%

Auxiliary commands

- [56: Clear] is valid for the second TxD byte or later. All commands back to the first byte are cleared.
- When [02: Error] occurs, [41: ClearError] is valid. The previous command (one byte) is cleared.
- [40: Enter] has no effect.

**B6: Rev Shuttle Key** **Basic/JVC-1 Table**

Shuttle search playback in the reverse direction. Specify the Fwd Shuttle Mode. The speed is specified by the second byte. Specify the adjustment speed.

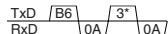

- The second TxD byte consists of numeric data and is expressed with "30", "31", "32" ... "38", "39", "3A", "3B" and "3C".
- When invalid data is received, the VCR returns "02: Error".
- The speeds corresponding to each value are shown below.

Data	30	31	32	33	34	35	36	37	38
Speed	Still	0.03	0.09	0.20	0.50	1	2	4	6

39	3A
10	17 or 32

Auxiliary commands

- [56: Clear] is valid for the second TxD byte or later. All commands back to the first byte are cleared.
- When [02: Error] occurs, [41: ClearError] is valid. The previous command (one byte) is cleared.
- [40: Enter] has no effect.

**C0: Auto Edit Key** **Basic Table**

Executes Auto Edit on the VCR.

- The editing channel must be selected with [E5/E9: Edit Preset].
- Use with [FA: Rec Request].

- Set the preroll time with [E6: Preroll Time Preset].
- When preroll time is not specified, the VCR's menu setting is used.
- The VCR returns [01: Complete] after Auto Edit is complete.
- [0B: NAK] is returned to the player.

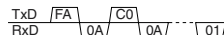

**C1: Preview Key** **Basic Table**

Execute Preview on the VCR.

- The editing channel must be selected with [E5/E9: Edit Preset].
- Use with [FA: Rec Request].
- Set the preroll time with [E6: Preroll Time Preset].
- When preroll time is not specified, the VCR's menu setting is used.
- The VCR returns [01: Complete] after Preview is complete.
- [0B: NAK] is returned to the player.

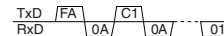

**C2: Review Key** **Basic Table**

Execute Review on the VCR.

- [C0: Auto Edit] must be complete.
- Set the preroll time with [E6: Preroll Time Preset].
- When preroll time is not specified, the VCR's menu setting is used.
- The VCR returns [01: Complete] after Review is complete.
- [0B: NAK] is returned to the player.

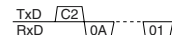

**C4: Full EE On** **Basic/JVC-1 Table**

Checks VCR's input signals.

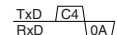

The VCR returns [0B: NAK] to the player.

**C5: EE Off** **Basic/JVC-1 Table**

Releases EE check.

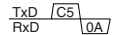

**C8: Select EE On** **Basic Table**

Checks the input signals to the editing channel selected by [E5/E9: Edit Preset].

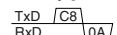

The VCR returns [0B: NAK] to the player.

**C9: EE Off** **Basic Table**

Releases EE check.

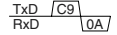

13-2 RS-232C Commands

**CA: Rec Key** **Basic/JVC-1 Table**

Recording  
Use with [FA: Rec Request].

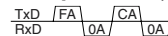

The VCR returns [0B: NAK] to the player.

**CB: Rec Pause Key** **Basic/JVC-1 Table**

Recording is paused.  
Use with [FA: Rec Request].

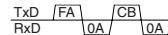

The VCR returns [0B: NAK] to the player.

**CE: Edit On Key** **Basic Table**

The channel selected with [E5: Edit Preset] is engaged in the Edit mode.  
Use with [FA: Rec Request].

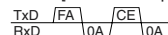

The VCR returns [0B: NAK] to the player.

**CF: Edit Off Key** **Basic Table**

Stops the editing operation.  
The VCR enters the Play mode after editing is complete.

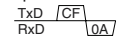

The VCR returns [0B: NAK] to the player.

**D1: Device Type Request** **JVC-1 Table**

Returns the model name of the connected VCR.



- Uses ASCII code to express "0" to "9", "a" to "z", and "space".
- For example, d = "64", 9 = "39", 5 = "35" and space = "20" for the BR-D95.

**D3: Memory Switch Sense** **JVC-1 Table**

Recalls menu switch content.

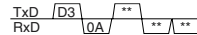

- Refer to "Menu Switch setting" to find out more about menu switch contents.
- Specify the address data you want to recall with the second TxD byte.

The corresponding addresses are as follows.

- |                                |                           |
|--------------------------------|---------------------------|
| 01 :Servo/System-1 information | 08 :System-2 information  |
| 10 :System-3 information       | 20 :System-4 information  |
| 40 :System-5 information       | 80 :System-6 information  |
| 89 :System-7 information       | 90 :System-8 information  |
| 87 :System-9 information       | 09 :System-10 information |
| 91 :System-11 information      | 92 :System-12 information |
| 94 :System-14 information      |                           |
| 0a :Video information-2        | 0b :Video information-3   |
| 0c :Video information-4        | 0d :Video-5 information   |
| 1b :Video-6 information        | 0e :Video-7 information   |
| 1e :Video-8 information        | 1c :Video-9 information   |
| 0f :Video-10 information       | 1f :Video-11 information  |
| 1d :Video-12 information       | 05 :Audio-2 information   |
| 06 :Audio-3 information        | 07 :Audio-4 information   |
| 03 :Audio-5 information        | 30 :Audio-6 information   |

- |                            |                            |
|----------------------------|----------------------------|
| 31 :Audio-7 information    | 80 :TimeCode-1 information |
| 81 :TimeCode-2 information | 79 :TimeCode-3 information |
| 77 :TimeCode-4 information | 78 :TimeCode-5 information |
| 82 :OnScreen-1 information | 83 :OnScreen-2 information |
| 84 :TBC information-1      | 86 :TBC information-3      |

- The third and fourth RxD bytes express individual bit information (Data1/Data2) for the specified address.
- When invalid data is received, the VCR returns "02: Error".

Auxiliary commands

- When [02: Error] occurs, [56: Clear] is valid. All commands back to the first TxD byte are cleared.
- When [02: Error] occurs, [41: ClearError] is valid. The previous command (one byte) is cleared.
- [40: Enter] is invalid.

**D4: Tape Remain Sense** **JVC-1 Table**

Recalls remaining tape time information.

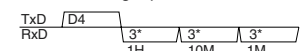

**D6: Preroll Time Sense** **Basic Table**

Shows the preroll time setting.  
The VCR returns the value set by [E6: Preroll Time Preset] or the value set with the VCR's menu.

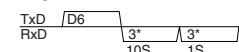

**D7: Status Sense** **Basic/JVC-1 Table**

Shows the VCR status.



- For an explanation of the meaning of each bit, refer to "Sense command details".

**D8: Current TC Sense** **Basic/JVC-1 Table**

Shows the current TC time data.



- Values after the first RxD byte from 0 to 9 are expressed in ASCII code.

**D9: Current CTL Sense** **Basic/JVC-1 Table**

Shows the current CTL time data.

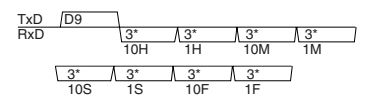

- Values after the first RxD byte from 0 to 9 are expressed in ASCII code.
- The most significant bit at 10H expresses "minus".

13-2 RS-232C Commands

**DA: In Data Sense** **Basic Table**

Shows the set IN point.

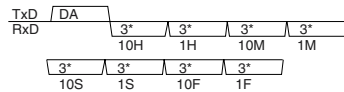

- Values after the first RxD byte from 0 to 9 are expressed in ASCII code.

**DB: Out Data Sense** **Basic Table**

Shows the set OUT point.

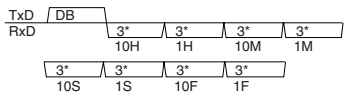

- Values after the first RxD byte from 0 to 9 are expressed in ASCII code.

**DB: Panel Switch Sense** **JVC-1 Table**

Shows the various settings on the front panel.



- For an explanation of the meaning of each bit, refer to "EC: Panel Switch Preset".

**DC: Current TC UB Sense** **Basic Table**

Shows the current TC UB data.

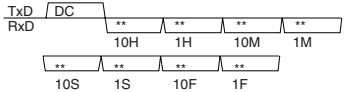

- Values after the first RxD byte from 0 to f (HEX) are expressed in ASCII code.

**DD: JVC Status Sense** **Basic/JVC-1 Table**

Shows the VCR status.



- For an explanation of the meaning of each bit, refer to "Sense command details".

**DE: Current Sub Tc Sense** **Basic Table**

Shows the current SUB-TC time data.

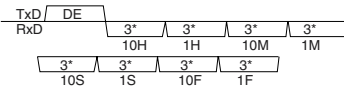

- Values after the first RxD byte from 0 to 9 are expressed in ASCII code.

**DF: Current Sub UB Sense** **Basic Table**

Shows the current SUB TC UB data.

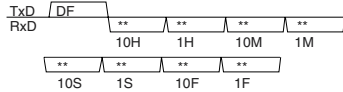

- Values after the first RxD byte from 0 to f (HEX) are expressed in ASCII code.

**E0: TC Data Preset** **Basic Table**

Presents the TC data.

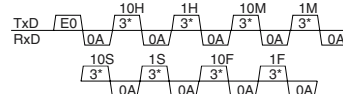

- Values after the second TxD byte from 0 to 9 are expressed in ASCII code.

**Auxiliary commands**

- [56: Clear] is valid for the second TxD byte or later. All commands back to the first byte are cleared.
- When [02: Error] occurs, [41: ClearError] is valid. The previous command (one byte) is cleared.
- [40: Enter] is valid for the second TxD byte or later. Whatever has not yet been specified is regarded as [30: Zero].

**E1: TC UB Data Preset** **Basic Table**

Presents the TC UB data.

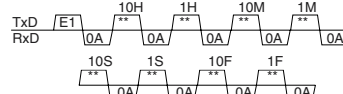

- Values after the first RxD byte from 0 to f (HEX) are expressed in ASCII code.

**Auxiliary commands**

- [56: Clear] is valid for the second TxD byte or later. All commands back to the first byte are cleared.
- When [02: Error] occurs, [41: ClearError] is valid. The previous command (one byte) is cleared.
- [40: Enter] is valid for the second TxD byte or later. Whatever has not yet been specified is regarded as [30: Zero].

**E2: Counter Reset** **Basic JVC-1 Table**

Resets the CTL counter.

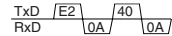

**Auxiliary commands**

- [56: Clear] is valid for the second TxD byte. All commands back to the first byte are cleared.
- When [02: Error] occurs, [41: ClearError] is valid. The previous command (one byte) is cleared.
- [40: Enter] is required for the second TxD byte.

13-2 RS-232C Commands

**E3: In Data Preset** **Basic/JVC-1 Table**

Presents the IN point.

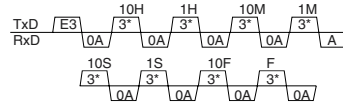

- Values after the second TxD byte from 0 to 9 are expressed in ASCII code.

**Auxiliary commands**

- [56: Clear] is valid for the second TxD byte or later. All commands back to the first byte are cleared.
- When [02: Error] occurs, [41: ClearError] is valid. The previous command (one byte) is cleared.
- [40: Enter] is valid for the second TxD byte or later. Whatever has not yet been specified is regarded as [30: Zero].

**E4: Out Data Preset** **Basic/JVC-1 Table**

Presents the OUT point.

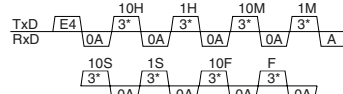

- Values after the second TxD byte from 0 to 9 are expressed in ASCII code.

**Auxiliary commands**

- [56: Clear] is valid for the second TxD byte or later. All commands back to the first byte are cleared.
- When [02: Error] occurs, [41: ClearError] is valid. The previous command (one byte) is cleared.
- [40: Enter] is valid for the second TxD byte or later. Whatever has not yet been specified is regarded as [30: Zero].

**E5: Edit Preset** **Basic Table**

Selects the edit mode.

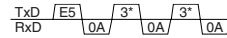

- Each bit is defined as follows:

	7	6	5	4	3	2	1	0
First byte	0	0	1	1	0	INS	ASM	Video
Second byte	0	0	1	1	0	TC	Aud2	Aud1

**Auxiliary commands**

- [56: Clear] is valid for the second TxD byte or later. All commands back to the first byte are cleared.
- When [02: Error] occurs, [41: ClearError] is valid. The previous command (one byte) is cleared.
- [40: Enter] is invalid.

**E6: Preroll TimePreset** **Basic Table**

Sets the preroll time.

The set value should be less than 59 seconds. If the preroll time is not set with this command, use the VCR's menu switch setting.

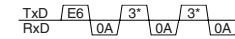

**Auxiliary commands**

- [56: Clear] is valid for the second TxD byte or later. All commands back to the first byte are cleared.
- When [02: Error] occurs, [41: ClearError] is valid. The previous command (one byte) is cleared.
- [40: Enter] is invalid.

**E7: Timer Mode Select** **Basic/JVC-1 Table**

Switches the current timer.

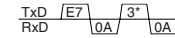

- Each bit is defined as follows:

	7	6	5	4	3	2	1	0
First byte	0	0	1	1	0	UB	CTL	TC

- CTL = 32, LTC = 31, LTC UB = 35

**Auxiliary commands**

- [56: Clear] is valid for the second TxD byte or later. All commands back to the first byte are cleared.
- When [02: Error] occurs, [41: ClearError] is valid. The previous command (one byte) is cleared.
- [40: Enter] is invalid.

**E8: Analog Data Set** **JVC-1 Table**

Sets values for specified audio and video settings.

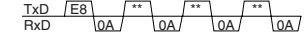

- Selects the setting item and sets the data as shown below with the input values for the second TxD byte or later.
- The second byte: Selects the setting item (DATA0)
- The third/fourth byte: Sets the data (DATA1, DATA2)

A/V Setting items	DATA0	DATA1	DATA2	
Tracking volume	20	00-FF	—	
Output video level	70	00-C0	—	
Output chroma level	71	00-C0	—	
Output video H phase	72	00-FF	—	
Output setup level	73	00-FF	—	
Output chroma phase	74	00-FF	—	
Output video V phase	75	03-0D	—	
Output system phase	76	03-0D	—	
Output SC phase	77	Low-order	High-order	0000-011F
Output SCH phase	78	00-FF	—	
Output audio phase	79	Low-order	High-order	20FE-D002

**Auxiliary commands**

- [56: Clear] is valid when [02: Error] occurs. All commands back to the first TxD byte are cleared.
- When [02: Error] occurs, [41: ClearError] is valid. The previous command (one byte) is cleared.
- [40: Enter] is invalid.

13-2 RS-232C Commands

**E9: Edit Preset 2** **Basic Table**

Selects the Edit mode for 4 channels.

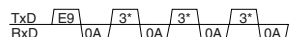

- Each bit is defined as follows:

	7	6	5	4	3	2	1	0
First byte	0	0	1	1	0	INS	ASM	Video
Second byte	0	0	1	1	0	TC	Aud2	Aud1
Third byte	0	0	1	1	DA4	DA3	DA2	DA1

**Auxiliary commands**

- [56: Clear] is valid for the second TxD byte or later. All commands back to the first byte are cleared.
- When [02: Error] occurs, [41: ClearError] is valid. The previous command (one byte) is cleared.
- [40: Enter] is invalid.

**E8: TC Switch Preset** **Basic Table**

Switches the time code generator function.

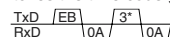

- Each bit is defined as follows:

	7	6	5	4	3	2	1	0
The first byte	0	0	1	1	0	REC RUN	REGEN	EXT

- REC RUN : 1: Rec Run 0: Free Run  
REGEN : 1: Regene 0: Preset  
EXT : 1: Ext 0: Int
- Auxiliary commands
- [56: Clear] is valid for the second TxD byte or later. All commands back to the first byte are cleared.
- When [02: Error] occurs, [41: ClearError] is valid. The previous command (one byte) is cleared.
- [40: Enter] is invalid.

**E3: Panel Switch Preset** **JVC-1 Table**

Switches various settings on the front panel.

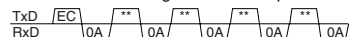

- Settings are defined with the input values for the second TxD byte or later. The bit assignment is shown below.

Second byte (DATA0)

	7	6	5	4	3	2	1	0
MS CH4 L	MS CH4 R	MS CH3 L	MS CH3 R		VID GEN	DIG VID	LINE	

Third byte (DATA1)

	7	6	5	4	3	2	1	0
MS CH2 L	MS CH2 R	MS CH1 L	MS CH1 R		UB	TC		

Fourth byte (DATA2)

	7	6	5	4	3	2	1	0
IS CH4 1	IS CH4 0	IS CH3 1	IS CH3 0		Rem /9pin			

Fifth byte (DATA3)

	7	6	5	4	3	2	1	0
IS CH2 1	IS CH2 0	IS CH1 1	IS CH1 0	MON /IPT	CF SW	CF FLD	PB /EE	

VIDEO INPUT SELECT

Setting	Bit name		
	VID GEN	DIG VID	LINE
CPN	0	0	0
LINE	0	0	1
SIF	0	1	—
Internal	1	—	—

AUDIO INPUT SELECT

Setting	Bit name	
	IS**1	IS**2
ANA	0	0
AES/EBU	0	1
SDI	1	—
Internal	1	1

AUDIO MONITOR SELECT

Setting	Bit name	
	MS**L	MS**R
OFF	0	0
R CH	0	1
L CH	1	0
L+R CH	1	1

COUNTER

Setting	Bit name	
	UB	TC
CTL	0	0
TC	—	1
UB	1	0

PB PB/EE

Setting	Bit name
	PB/EE
PB/EE	0
PB	1

REMOTE

Setting	Bit name
	Rem/9pin
REMOTE	1
LOCAL	0

**Auxiliary commands**

- [56: Clear] and [41: ClearError] are invalid.
- [40: Enter] is invalid.

13-2 RS-232C Commands

**ED: Memory Switch Preset** **Basic/JVC-1 Table**

Rewrites the contents of the menu switch.

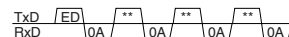

- Refer to "Menu Switch Setting" to find out more about menu switch contents.
- The setting of the menu switch changed with this command is reset to the default setting when the VCR is turned OFF.
- The second byte expresses the address (Data0).

The corresponding addresses are as follows.

- 01 : Servo/System-1 information
- 10 : System-3 information
- 40 : System-5 information
- 89 : System-7 information
- 87 : System-9 information
- 91 : System-11 information
- 94 : System-14 information
- 0a : Video information-2
- 0b : Video information-3
- 0c : Video information-4
- 1b : Video-6 information
- 1e : Video-8 information
- 0f : Video-10 information
- 1d : Video-12 information
- 06 : Audio-3 information
- 03 : Audio-5 information
- 31 : Audio-7 information
- 81 : TimeCode-2 information
- 77 : TimeCode-4 information
- 82 : OnScreen-1 information
- 84 : TBC information-1
- 08 : System-2 information
- 20 : System-4 information
- 88 : System-6 information
- 90 : System-8 information
- 09 : System-10 information
- 92 : System-12 information
- 0d : Video-5 information
- 0e : Video-7 information
- 1c : Video-9 information
- 1f : Video-11 information
- 05 : Audio-2 information
- 07 : Audio-4 information
- 30 : Audio-6 information
- 80 : TimeCode-1 information
- 79 : TimeCode-3 information
- 78 : TimeCode-5 information
- 83 : OnScreen-2 information
- 86 : TBC information-3

- The third and fourth bytes express individual bit information for the specified address. These are expressed as Data1/Data2 information.
- The rewritten data can be checked with D3: MemorySwitchSense. The D3 command applies only to JVC Table-1.

**Auxiliary commands**

- When [02: Error] occurs, [56: Clear] is valid. All commands back to the first TxD byte are cleared.
- When [02: Error] occurs, [41: ClearError] is valid. The previous command (one byte) is cleared.
- [40: Enter] is invalid.

**F6: JVC Table-1 On** **Basic/JVC-1 Table**

Use the JVC Table-1 commands.

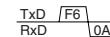

**F7: Basic Table On** **Basic/JVC-1 Table**

Use the Basic Table commands. JVC Table-1 is set to OFF.

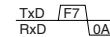

**FA: Rec/DubRequest** **Basic/JVC-1 Table**

Send this command before sending commands such as [CA: REC], [CB: REC]Pause.

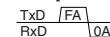

- The recording standby mode is maintained until the REC or STOP command or Error release command is transmitted.

**FB: VTR IND** **Basic/JVC-1 Table**

Checks that a VCR is connected.

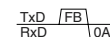

13-3 Speed/data correspondence table

Data	Speed	Data	Speed	Data	Speed
00-1D	STILL	80	1.00	B8	7.50
1E-2C	0.03	81	1.04	B9	7.80
2D-3A	0.07	82	1.07	BA	8.00
3B-44	0.10	83	1.11	BB	8.40
45-4B	0.13	84	1.15	BC	8.70
4C-50	0.17	85	1.20	BD	9.00
51-56	0.20	86	1.24	BE	9.30
57-59	0.23	87	1.30	BF	9.70
5A-5C	0.27	88	1.33	C0-C1	10.00
5B-60	0.30	89	1.38	C2	10.70
61	0.33	8A	1.43	C3-C4	11.10
62	0.34	8B	1.49	C5	11.50
63	0.35	8C	1.54	C6	12.40
64	0.37	8D	1.60	C7-C8	13.00
65	0.38	8E	1.65	C9-CA	14.00
66-68	0.40	8F	1.72	CB-CC	15.00
69	0.44	90	1.78	CD	16.00
6A	0.45	91	1.84	CE-CF	17.00
6B	0.47	92-94	2.00	D0-D1	18.00
6C-6E	0.50	95	2.13	D2	19.00
6F	0.54	96	2.21	D3	20.00
70	0.56	97	2.29	D4-D5	21.00
71	0.58	98	2.37	D6	22.00
72	0.60	99	2.46	D7	23.00
73	0.63	9A	2.55	D8	24.00
74	0.65	9B	2.64	D9	25.00
75	0.67	9C	2.74	DA-DB	26.00
76	0.70	9D	2.84	DC	27.00
77	0.72	9E-A0	3.00	DD	28.00
78	0.75	A1	3.30	DE	29.00
79	0.78	A2	3.40	DF	31.00
7A	0.80	A3	3.50	E0	32.00
7B	0.84	A4	3.70	E1	33.00
7C	0.87	A5	3.80	E2	34.00
7D	0.90	A6-A8	4.00	E3	35.00
7E	0.93	A9	4.40	E4	37.00
7F	0.97	AA	4.50	E5	38.00
		AB	4.70	E6	39.00
		AC-AE	5.00	E7	41.00
		AF	5.40	E8	42.00
		B0	5.60	E9	44.00
		B1	5.80	EA	45.00
		B2	6.00	EB	47.00
		B3	6.30	EC	49.00
		B4	6.50	ED	50.00
		B5	6.70	EE	52.00
		B6	7.00	EF	54.00
		B7	7.20	F0	56.00
				F1-FF	58.00

13-4 Contents of the sense commands

The bit assignment for each status data byte returned with D7: Status Sense is as follows:  
Status (No. 1): First byte

Bit	Status	Remarks
Bit-7	Undefined	Always "1"
Bit-6	Undefined	Always "0"
Bit-5	Short FF/REW	Short FF: Detects the beginning of the tape and fast-forwards the tape until Stand-By On is engaged. Short REW: Detects tape end and rewinds the tape until Stand-By On is engaged.
Bit-4	REC Inhibit	Indicates that a cassette with no safety tab has been loaded or that recording prohibition has been selected with the VCR's memory switch.
Bit-3	Cassette Out	No tape is loaded in the VCR.
Bit-2	Servo Lock	During tape playback, both the capstan and drum servo are locked.
Bit-1	Undefined	Always "0"
Bit-0	Error	Shows that an invalid command has been received. In this status, a continuously transmitted command will not be accepted. To release the Error mode, cancel the commands one byte at a time with 41: Error Clear. Or cancel all commands with 56: Clear.

Status (No. 2) Second byte

Bit	Status	Remarks
Bit-7	EE	Externally input video signals are output.
Bit-6	A1 EE Mode	Externally input audio (A1) signals are output.
Bit-5	Video Mute	Video signals are muted (returned from the DS microprocessor).
Bit-4	Audio Mute	Audio signals are muted (returned from the AUDIO microprocessor).
Bit-3	Warning	Shows that the VCR is in the Auto-Off mode.

Bit-2	DEW	Condensation.
Bit-1	Tape Begin	The tape winding start sensor is detected.
Bit-0	Tape End	The tape winding end sensor is detected.

Status (No. 3) Third byte

Bit	Status	Remarks
Bit-7	Unused	Always "0"
Bit-8	Unused	Always "0"
Bit-6	Unused	Always "0"
Bit-5	Unused	Always "0"
Bit-4	Unused	Always "0"
Bit-3	Unused	Always "0"
Bit-2	Unused	Always "0"
Bit-1	Search mode	During CueUp/Preroll (only when controlled from the RS-232C)
Bit-0	Unused	Always "0"

Status (No. 4) Forth byte

Bit	Status	Remarks
Bit-7	Play Mode	Playback
Bit-6	FF Mode	Fast-forward
Bit-5	REW mode	Rewind
Bit-4	Stop mode	Stop
Bit-3	Stand-by mode	Standby-Off
Bit-2	Eject	Tape is ejected
Bit-1	REC mode	Record
Bit-0	Unused	Always "0"

Status (No. 5) Fifth byte

Bit	Status	Remarks
Bit-7	Pause mode	Pause
Bit-6	Unused	Always "0"
Bit-5	Shuttle Fwd	During Shuttle/Jog/Variable search in the forward direction
Bit-4	Shuttle Rev	During Shuttle/Jog/Variable search in the reverse direction
Bit-3	Speed Code-3	Refer to the table below.
Bit-2	Speed Code-2	Refer to the table below.
Bit-1	Speed Code-1	Refer to the table below.
Bit-0	Speed Code-0	Refer to the table below.

	0≤SPD <0.03	0.03≤SPD <0.1	0.1≤SPD <0.2	0.2≤SPD <0.5	0.5≤SPD <1.0	1.0≤SPD <2.0	2.0≤SPD <4.0	4.0≤SPD <6.0	6.0≤SPD <10	10≤SPD <17	17≤SPD <32	32≤SPD
Speed Code-3	0	0	0	0	0	0	0	0	1	1	1	1
Speed Code-2	0	0	0	0	1	1	1	1	0	0	0	0
Speed Code-1	0	0	1	1	0	0	1	1	0	0	1	1
Speed Code-0	0	1	0	1	0	1	0	1	0	1	0	1

## 13 RS-232C protocol

### 13-4 Contents of the sense commands

The bit assignment for status data each byte returned with DD: JVC Status Sense is as follows:

JVC Status (No. 1) First byte

Bit	Status	Remarks
Bit-7	Undefined	Always "1"
Bit-6	Undefined	Always "0"
Bit-5	Unused	Always "0"
Bit-4	Unused	Always "0"
Bit-3	Unused	Always "0"
Bit-2	Unused	Always "0"
Bit-1	JVC Table 1	JVC Table-1 is selected.
Bit-0	Local	"Local" is selected.

JVC Status (No. 2) Second byte

Bit	Status	Remarks
Bit-7	Generator	The TC generator is selected for the current timer mode.
Bit-6	UB	UB is selected for the current timer mode.
Bit-5	TC	TC is selected for the current timer mode.
Bit-4	CTL	CTL is selected for the current timer mode.
Bit-3	CTL Interpolation	CTL Interpolation
Bit-2	DF	DF is selected for the current timer mode.
Bit-1	LTC	LTC is selected for the current timer mode.
Bit-0	Unused	Always "0"

JVC Status (No. 3) Third byte

Bit	Status	Remarks
Bit-7	REC Run	TC setting is 1: REC Run 0: Free Run.
Bit-6	Regen	TC setting is 1: Regen 0: Preset.
Bit-5	Ext	TC setting is 1: Ext 0: Int
Bit-4	TC Ins Lamp	TC Insert editing mode is selected.
Bit-3	DA1 Ins Lamp	Audio-1 Insert editing mode is selected.
Bit-2	DA2 Ins Lamp	Audio-2 Insert editing mode is selected.
Bit-1	V Ins Lamp	Video Insert editing mode is selected.
Bit-0	Assem Lamp	Assemble editing mode is selected.

JVC Status (No. 4) Forth byte

Bit	Status	Remarks
Bit-7	TBC board	The TBC board is installed. Always "1"
Bit-6	TC board	The TC board is installed. Always "1"
Bit-5	DA3 Ins Lamp	Audio-3 Insert editing mode is selected.
Bit-4	DA4 Ins Lamp	Audio-4 Insert editing mode is selected.
Bit-3	Auto mode	Auto Edit/Preview/Review being executed.
Bit-2	Unused	Always "0"
Bit-1	Unused	Always "0"
Bit-0	Unused	Always "0"

## 13 RS-232C protocol

### 13-5 Menu switch setting information

The set value expresses the corresponding bit value. 2 bits or more are expressed as follows:

0	0
1	1
2	10
3	11
4	100
5	101
:	:

SERVO information/SYSTEM information-1

DATA0 01

	7	6	5	4	3	2	1	0
D1	005					002		
D2							003	003

Corresponding menu switches

No.	Menu switch name	Setting	Set value
002	OPERATION LOCK	OFF ON	0 1
003	SYNC SELECT	EXT AUTO	1 3
005	AUTO TRACKING	OFF ON	0 1

SYSTEM information-2

DATA0 08

	7	6	5	4	3	2	1	0
D1				312		302	301	300
D2								D95

Corresponding menu switches

No.	Menu switch name	Setting	Set value
D95	525/625	525 625	0 1
300	DIRECT EJECT	OFF ON	0 1
301	DIRECT SEARCH	OFF ON	0 1
302	BACK SPACE	OFF ON	0 1
312	AUTO REW AT TAPE END	OFF ON	0 1

SYSTEM information-3

DATA0 10

	7	6	5	4	3	2	1	0
D1					307	307	307	
D2	328		311	314				

Corresponding menu switches

No.	Menu switch name	Setting	Set value
307	PAUSE/STILL/STP TIME	1 SEC 10 SEC 30 SEC 1 MIN 2 MIN 3 MIN 4 MIN 5 MIN	0 1 2 3 4 5 6 7
311	AUTO PLAY AT TAPE BEGIN	OFF ON	0 1
314	PB/EE MODE	STOP/FF/REW STOP	0 1
328	EDIT POINT CLEAR	DISABLE ENABLE	0 1

SYSTEM information-4

DATA0 20

	7	6	5	4	3	2	1	0
D1	317	317						
D2		323		320	320	320	320	

Corresponding menu switches

No.	Menu switch name	Setting	Set value
317	9PIN DEVICE ID	JVC D80 JVC D860/D92/D95 DVW-A500 USE SETTING (382-385)	0 1 2 3
320	PREROLL TIME	0SEC : 15SEC	0 : 15
323	PREROLL END MODE	STANDBY-ON STILL	0 1

SYSTEM information-5

DATA0 40

	7	6	5	4	3	2	1	0
D1			391		395			
D2	390	390	390	390			393	393

Corresponding menu switches

No.	Menu switch name	Setting	Set value
390	SWAP VTR SELECT	AUTO : TYPE-9	0 : 9
391	SYNCHRONIZATION	DISABLE ENABLE	0 1
393	SYNC GRADE	ACCURATE +/-1FRAME +/-2FRAME ROUGH	0 1 2 3
395	AUTO-EE	RECORDER ONLY AUTO-EE	0 : 1

## 13 RS-232C protocol

### 13-5 Menu switch setting information

#### SYSTEM information-6

DATA0 88

	7	6	5	4	3	2	1	0
D1			319	319		351		
D2	351	351						

#### Corresponding menu switches

No.	Menu switch name	Setting	Set value
319	FF/REW MAX SPEED	X60	0
		X32	1
		X17	2
351	PREREAD	VID OFF/AUD OFF	0
		VID ON/AUD OFF	1
		VID OFF/AUD ON	2
		VID ON/AUD ON	3

#### SYSTEM information-7

DATA0 89

	7	6	5	4	3	2	1	0
D1								
D2	359	359	359		357			

#### Corresponding menu switches

No.	Menu switch name	Setting	Set value
357	DIAG AT POWER ON	OFF	0
		ON	1
359	JOG FEELING (REMOTE)	TYPE-1	0
		TYPE-2	1
		TYPE-3	2
		TYPE-4	3
		TYPE-5	4

#### SYSTEM information-8

DATA0 90

	7	6	5	4	3	2	1	0
D1								
D2					363	363	363	

#### Corresponding menu switches

No.	Menu switch name	Setting	Set value
363	CONTROLLER SELECT	DEFAULT	0
		RM-450	1
		CMX AEGIS	2
		:	:
		NOT DEFINED	7

#### SYSTEM information-10

DATA0 09

	7	6	5	4	3	2	1	0
D1	374	373	372	371		369	368	367
D2		386	381				340	340

#### Corresponding menu switches

No.	Menu switch name	Setting	Set value
340	SEARCH SPEED	X32	0
		X17	1
		X6	3
367 (525)	EDIT INTERRUPTION	OFF	0
		ON	1
368	STARTING PIC FREEZE	OFF	0
		ON	1
369	PARA-RUN	OFF	0
		ON	1
371	INPUT SELECT SAFETY	OFF	0
		ON	1
372	P+R AT SWAP MODE	ENABLE	0
		DISABLE	1
373	MATCH FRAME	OFF	0
		ON	1
374	MENU OPEN SAFETY	OFF	0
		ON	1
381	JOG FEELING	NORMAL	0
		INSENSITIVE	1
386	MUTING AT NO TAPE	DISABLE	0
		ENABLE	1

#### SYSTEM information-11

DATA0 91

	7	6	5	4	3	2	1	0
D1	378	378	377	377	376	376	375	375
D2								

#### Corresponding menu switches

No.	Menu switch name	Setting	Set value
375	AUDIO EDIT PRESET CH1	NO DEFINITION	0
		CH1	1
		CH2	2
		CH1 OR CH2	3
376	AUDIO EDIT PRESET CH2	NO DEFINITION	0
		CH1	1
		CH2	2
		CH1 OR CH2	3
377	AUDIO EDIT PRESET CH3	NO DEFINITION	0
		CH1	1
		CH2	2
		CH1 OR CH2	3
378	AUDIO EDIT PRESET CH4	NO DEFINITION	0
		CH1	1
		CH2	2
		CH1 OR CH2	3

## 13 RS-232C protocol

### 13-5 Menu switch setting information

#### SYSTEM information-12

DATA0 94

	7	6	5	4	3	2	1	0
D1	387			009	008p	008p	008	008
D2	387	387p	387p	352				

#### Corresponding menu switches

No.	Menu switch name	Setting	Set value
008	CAP LOCK (525)	SWSEL	0
		2FLD	1
		4FLD	2
008p	CAP LOCK (625)	SWSEL	0
		2FLD	1
		4FLD	2
		8FLD	3
009	CAP RE-LOCKING DIR.	ACCELERATION	0
		DECELERATION	1
352	AUD PREREAD TIMING	NORMAL	0
		OFFSET	1
387	CF FLAG REPLY (525)	4FLD	1
		2FLD OR 4FLD	2
		OFF	3
387p	CF FLAG REPLY (625)	8FLD	0
		4FLD OR 8FLD	1
		2FLD OR 4FLD OR 8FLD	2
		OFF	3

#### SYSTEM information-14

DATA0 92

	7	6	5	4	3	2	1	0
D1	383	383	383	383	382	382	382	382
D2	385	385	385	385	384	384	384	384

#### Corresponding menu switches

No.	Menu switch name	Setting	Set value
382	9 PIN ID (1ST)	0	0
		:	:
		F	15
383	9 PIN ID (2ND)	0	0
		:	:
		F	15
384	9 PIN ID (3RD)	0	0
		:	:
		F	15
385	9 PIN ID (4TH)	0	0
		:	:
		F	15

#### VIDEO information-2

DATA0 0A

	7	6	5	4	3	2	1	0
D1		120	111	119	112	112	111	
D2	104	104		111				

#### Corresponding menu switches

No.	Menu switch name	Setting	Set value
104	CPN LEVEL/SETUP (525)	LOW/ON	0
		HIGH/ON	1
		LOW/OFF	2
		HIGH/OFF	3
111	VD REC SIGNAL SEL.	COLOR BAR	1
		BLACK	2
		MULTI BURST	4
		PULSE& BAR	5
112	ECC MODE	NORMAL	0
		NO CONCEAL	1
		NO CORRECTION	2
119	SLOW PICTURE	FRAME	0
		FIELD	1
120	NO CTL MUTING	OFF	0
		ON	1

#### VIDEO information-3

DATA0 0B

	7	6	5	4	3	2	1	0
D1	139	139	139	139			138	138
D2	140	140	140	140	140	140	139	139

#### Corresponding menu switches

No.	Menu switch name	Setting	Set value
138	EXTRA LINE REC (525)	FIX	0
		USER (COLOR)	1
		USER (MONO)	2
139	EXTRA-L R1 SEL (525)	10	00
		11	01
		:	:
		22	12
		273	18
		:	:
140	EXTRA-L R2 SEL (525)	10	00
		11	01
		:	:
		22	12
		273	18
		:	:
	284	29	

## 13 RS-232C protocol

### 13-5 Menu switch setting information

#### VIDEO information-4

DATA0 0C	7	6	5	4	3	2	1	0
D1	144	144	144	144			143	143
D2	145	145	145	145	145	145	144	144

#### Corresponding menu switches

No.	Menu switch name	Setting	Set value
143	EXTRA LINE PB (525)	MUTING	0
		AUTO	1
		USER SETTING	3
144	EXTRA- L P1SEL (525)	10	0
		:	:
		22	12
		273	18
		:	:
284	29		
145	EXTRA- L P2SEL (525)	10	0
		:	:
		22	12
		273	18
		:	:
284	29		

#### VIDEO information-5

DATA0 0D	7	6	5	4	3	2	1	0
D1				130			128	
D2	149	149	148	148	124			133

#### Corresponding menu switches

No.	Menu switch name	Setting	Set value
124	CHROMA ROTE	CPS	0
		CPN	1
128	PB EXTENSION LINE	OFF	0
		ON	1
130	H BLANKING WIDTH	WIDE	0
		NARROW	1
133	LINE SETUP (525)	OFF	0
		ON	1
148	IN VBLANK YCOMB (525)	OFF	0
		ON	1
		OFF WITH21	2
149	VIDEO OUT SELECT	NORMAL	0
		SYNC DELAY	1
		AROLL	2

#### VIDEO information-6

DATA0 1B	7	6	5	4	3	2	1	0
D1	139p	139p	139p	139p			138p	138p
D2	140p	140p	140p	140p	140p	140p	139p	139p

#### Corresponding menu switches

No.	Menu switch name	Setting	Set value
138p	EXTRA LINE REC (625)	FIX	0
		USER (COLOR)	1
		USER (MONO)	2
139p	EXTRA- LR1 SEL (625)	6	00
		:	:
		22	16
		319	18
		:	:
335	34		
623	35		
140p	EXTRA- LR2 SEL (625)	6	00
		:	:
		22	16
		319	18
		:	:
335	34		
623	35		

#### VIDEO information-7

DATA0 0E	7	6	5	4	3	2	1	0
D1		141	141	141	141	141	141	
D2		142	142	142	142	142	142	

#### Corresponding menu switches

No.	Menu switch name	Setting	Set value
141	EXTRA-L R3 SEL (525)	11	01
		:	:
		22	12
		273	18
		:	:
284	29		
142	EXTRA-L R4 SEL (525)	11	01
		:	:
		22	12
		273	18
		:	:
284	29		

## 13 RS-232C protocol

### 13-5 Menu switch setting information

#### VIDEO information-8

DATA0 1E	7	6	5	4	3	2	1	0
D1			141p	141p	141p	141p	141p	141p
D2			142p	142p	142p	142p	142p	142p

#### Corresponding menu switches

No.	Menu switch name	Setting	Set value
141p	EXTRA-L R3 SEL (625)	6	00
		:	:
		22	16
		319	18
		:	:
335	34		
623	35		
142p	EXTRA-L R4 SEL (625)	6	00
		:	:
		22	16
		319	18
		:	:
335	34		
623	35		

#### VIDEO information-9

DATA0 1C	7	6	5	4	3	2	1	0
D1	144p	144p	144p	144p			143p	143p
D2	145p	145p	145p	145p	145p	144p	144p	

#### Corresponding menu switches

No.	Menu switch name	Setting	Set value
143p	EXTRA LINE PB (625)	MUTING	0
		AUTO	1
		USER SETTING	3
144p	EXTRA-L P1 SEL (625)	6	00
		:	:
		22	16
		319	18
		:	:
335	34		
623	35		
145p	EXTRA-L P2 SEL (625)	6	00
		:	:
		22	16
		319	18
		:	:
335	34		
623	35		

#### VIDEO information-10

DATA0 0F	7	6	5	4	3	2	1	0
D1			146	146	146	146	146	146
D2			147	147	147	147	147	147

#### Corresponding menu switches

No.	Menu switch name	Setting	Set value
146	EXTRA-L P3 SEL (525)	00	00
		:	:
		12	12
		273	18
		:	:
284	29		
147	EXTRA-L P4 SEL (525)	00	00
		:	:
		12	12
		273	18
		:	:
284	29		

#### VIDEO information-11

DATA0 1F	7	6	5	4	3	2	1	0
D1			146p	146p	146p	146p	146p	146p
D2			147p	147p	147p	147p	147p	147p

#### Corresponding menu switches

No.	Menu switch name	Setting	Set value
146p	EXTRA-L P3 SEL (625)	6	00
		:	:
		22	16
		319	18
		:	:
335	34		
623	35		
147p	EXTRA-L P4 SEL (625)	6	00
		:	:
		22	16
		319	18
		:	:
335	34		
623	35		

13-5 Menu switch setting information

VIDEO information-12

DATA0 1D

7	6	5	4	3	2	1	0
D1							
D2				148p			

Corresponding menu switches

No.	Menu switch name	Setting	Set value
148p	IN VBLANK	OFF	0
	YCOMB (625)	ON	1

AUDIO information-2

DATA0 05

7	6	5	4	3	2	1	0
D1	214		214				
D2	221		219	219	215	216	

Corresponding menu switches

No.	Menu switch name	Setting	Set value
214	PB V.FADE	OFF	0
		5M	1
		10M	2
215	AUD REC VOLUME MODE1	CH1/CH2/CH3/CH4	0
		MAS-1 BAL-2 /MAS-3 BAL-4	1
216	AUD PB VOLUME MODE1	CH1/CH2/CH3/CH4	0
		MAS-1 BAL-2 /MAS-3 BAL-4	1
219	SEARCH REC CH	CH1/CH2	0
		CH3/CH4	1
		CH1+3/CH2+4	2
221	SEARCH PB AT 1+3/2+4	MUTING OFF	0
		MUTING ON	1

AUDIO information-3

DATA0 06

7	6	5	4	3	2	1	0
D1	233	233	232	232	261	223	222
D2			237	236			

Corresponding menu switches

No.	Menu switch name	Setting	Set value
222	MONITOR MIX MODE	AVERAGE	0
		RMS	1
		ADDITION	2
223	CH3/4 OUT SEL AT 2CH	MUTING	0
		CH1/2	1
232	AUDIO MON LEVEL LCH	-6DB	0
		0DB	1
		4DB	2
233	AUDIO MON LEVEL RCH	-6DB	0
		0DB	1
		4DB	2

236	PRO 48K S.R.CONV.	AUTO	0
		ON	1
237	EMBEDDED AUDIO	OFF	0
		ON	1
261	AUD SEL AT SEARCH	LINEAR TRACK	0
		DIGITAL TRACK	1

AUDIO information-4

DATA0 07

7	6	5	4	3	2	1	0
D1	227	227	226	226	225	224	224
D2	231	231	230	230	229	229	228

Corresponding menu switches

No.	Menu switch name	Setting	Set value
224	AUDIO IN LEVEL CH1	-6DB	0
		0DB	1
		4DB	2
		-20DB	3
225	AUDIO IN LEVEL CH2	-6DB	0
		0DB	1
		4DB	2
		-20DB	3
226	AUDIO IN LEVEL CH3	-6DB	0
		0DB	1
		4DB	2
		-20DB	3
227	AUDIO IN LEVEL CH4	-6DB	0
		0DB	1
		4DB	2
		-20DB	3
228	AUDIO OUT LEVEL CH1	-6DB	0
		0DB	1
		4DB	2
229	AUDIO OUT LEVEL CH2	-6DB	0
		0DB	1
		4DB	2
230	AUDIO OUT LEVEL CH3	-6DB	0
		0DB	1
		4DB	2
231	AUDIO OUT LEVEL CH4	-6DB	0
		0DB	1
		4DB	2

13-5 Menu switch setting information

AUDIO information-5

DATA0 03

7	6	5	4	3	2	1	0
D1							
D2	251	251		248	247		

Corresponding menu switches

No.	Menu switch name	Setting	Set value
247	DIG AUD AT ASYNC IN	NORMAL	0
		NOISE REDUCE	1
248	AUD DIG I/F MUTING	OFF	0
		ON	1
251	CH3/4 SOURCE SEL.	CH3--SW/CH4--SW	0
		CH3--CH1/CH4--SW	1
		CH3--SW/CH4--CH2	2
		CH3--CH1/CH4--CH2	3

AUDIO information-6

DATA0 30

7	6	5	4	3	2	1	0
D1	257	256	255	254	253		
D2							

Corresponding menu switches

No.	Menu switch name	Setting	Set value
253	CH1 REC SIGNAL SEL.	SILENCE	0
		1 kHz SINE	1
254	CH2 REC SIGNAL SEL.	SILENCE	0
		1 kHz SINE	1
255	CH3 REC SIGNAL SEL.	SILENCE	0
		1 kHz SINE	1
256	CH4 REC SIGNAL SEL.	SILENCE	0
		1 kHz SINE	1
257	AUDIO REF. SIGNAL LEV.	-20 dB	0
		-18 dB	1

TIME CODE information-1

DATA0 80

7	6	5	4	3	2	1	0
D1	401	401	401	401	400	400	400
D2	410	410			403	403	402

Corresponding menu switches

No.	Menu switch name	Setting	Set value
400	VITC LINE-1 SELECT (525)	10	0
		:	:
		20	10
401	VITC LINE-2 SELECT (525)	10	0
		:	:
		20	10
402	CTL DF SELECT (525)	TCG SETTING	0
		NON DROP	1
		DROP	2

403	REGEN MODE	TC&UB	0
		TC	1
		UB	2
410	AUTO REGEN MODE	ASM&INS	0
		ASM	1
		INS	2
		OFF	3

TIME CODE information-2

DATA0 81

7	6	5	4	3	2	1	0
D1			409				
D2							

Corresponding menu switches

No.	Menu switch name	Setting	Set value
409	EXT REGEN	LTC	0
		VITC	1

TIME CODE information-3

DATA0 79

7	6	5	4	3	2	1	0
D1	451		457		452	451	450
D2							

Corresponding menu switches

No.	Menu switch name	Setting	Set value
450	SUB TC (VITC) REC	OFF	0
		ON	1
451	VITC OUT SELECT	SUB TC	0
		TC	1
		OFF	2
452	SEARCH LTC	OFF	0
		ON	1
457	UB PRESET AUTO	OFF	0
		ON	1



## 13 RS-232C protocol

### 13-5 Menu switch setting information

#### TIME CODE information-4

DATA0 77	7	6	5	4	3	2	1	0
D1	401p	401p	401p	401p	400p	400p	400p	400p
D2								

#### Corresponding menu switches

No.	Menu switch name	Setting	Set value
400p	VITC LINE-1 SEL (625)	7	0
		:	:
		22	15
401p	VITC LINE-2 SEL (625)	7	0
		:	:
		22	15

#### TIME CODE information-5

DATA0 78	7	6	5	4	3	2	1	0
D1				421	421			
D2								

#### Corresponding menu switches

No.	Menu switch name	Setting	Set value
421	TCG CF FLAG	OFF	0
		ON	1
		AUTO	2

#### ON SCREEN information-1

DATA0 82	7	6	5	4	3	2	1	0
D1	502	502	502	502	501	501	501	501
D2								

#### Corresponding menu switches

No.	Menu switch name	Setting	Set value
501	CHARA H POSITION	0	0
		:	:
		6	6
502	CHARA V POSITION	0	0
		:	:
		11	11
505	REMAIN ENABLE	DISABLE	0
		:	:
		ENABLE	1

#### ON SCREEN information-2

DATA0 83	7	6	5	4	3	2	1	0
D1	504	504	513	512	504			
D2								

#### Corresponding menu switches

No.	Menu switch name	Setting	Set value
504	INFORMATION SELECT	TIME	0
		TIME + MODE	1
		TIME + SUBTC	3
		TIME + SUBTC + MODE	4
512	MUTING/ALARM MESSAGE	OFF ON	0 1
513	EDIT ON SCREEN	OFF ON	0 1

#### TBC information-1

DATA0 84	7	6	5	4	3	2	1	0
D1								
D2	620	620						

#### Corresponding menu switches

No.	Menu switch name	Setting	Set value
620	DUBBING LOOP	OFF	0
		3TIMES	1
		5TIMES	2
		10TIMES	3

#### TBC information-3

DATA0 86	7	6	5	4	3	2	1	0
D1								
D2							601	601

#### Corresponding menu switches

No.	Menu switch name	Setting	Set value
601	V BLANK MASK	OFF	0
		ON	1
		ON WITH 0.5H	2

## 14 TROUBLESHOOTING

### 14-1 WARNINGS WITH INDICATORS

This machine features self-diagnostic circuitry which allows it to detect and report any malfunctions that may occur. When a malfunction is detected, the cause will be shown on the monitor display and on the VCR's counter display. The warning code system consists of a main code (the code number) and a sub code (verbal description), e.g. 02 1 CONDENSATION ON DRUM. The front panel [AUTO OFF] indicator will normally be illuminated.

\* When the [AUTO OFF] indicator is illuminated, the unit is no longer operable. The [AUTO OFF] indicator can be canceled by turning the power off and on again. If the indicator remains lit even after turning the power off and on, malfunctions are possible. Consult your local JVC dealer.

Warning messages on  
the on-screen display

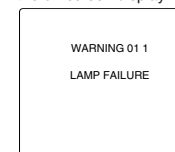

Warning messages on  
the counter display

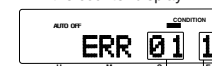

Main code | Sub code

As this unit uses a microcomputer, it may not function correctly due to noise from outside or interference noise. In this case, unplug the power cord and plug it again. Then, check the operation.

Warning code	On-screen display	Warning code information	Behavior and actions to be taken
0A	FAN FAILURE	The power turns OFF after about 9 minutes.	Turn the [POWER] switch OFF. Wait for at least 5 minutes, then turn the power ON again. If the warning indication is displayed again, consult your local JVC dealer.
01 1 (AUTO OFF)	LAMP FAILURE	Tape sensor LED broken.	Behavior: Stops, with no operation possible. Action: Turn the power off and then on.
02 1	CONDENSATION ON DRUM	Condensation on drums.	Behavior: Cassette ejected and drum begins to rotate. When condensation is eliminated, the indicator goes out and cassette can be loaded. Action: Leave the power ON and wait until the warning message goes out.
06 1	INVALID ERROR	S-VHS/VHS cassette in use.	Behavior: Cassette ejected. Action: Use Digital-S cassette tape.
08 1 (AUTO OFF)	SUP TENSION FAILURE	Tape tension abnormal.	Behavior: Stops, with no operation possible. Action: Turn the power off and then on.
32 1~ 32 2	FAILURE LOADING	Tape loading not possible.	Behavior: Cassette ejected. Action: Load the cassette again.
33 1~ 33 2 (AUTO OFF)	FAILURE UNLOADING	Tape unloading not possible.	Behavior: Stops, with no operation possible. Action: Turn the power off and then on.

## 14 TROUBLESHOOTING

### 14-1 WARNINGS WITH INDICATORS

Warning code	On-screen display	Warningcode information	Behavior and actions to be taken
41 1 (AUTO OFF)	CASSETTE EJECT FAILURE	Cassette does not come out in Eject.	Behavior: Stops, with no operation possible. Action: Turn the power off and then on.
56 1~ 56 9	TAPE DEFECTIVE	Tape defect. Tape loose	Behavior: Cassette ejected. Action: If no abnormality is found in tape, reload the cassette.
57 1~ 57 2	END LEADER DETECTION	Tape end sensor abnormal.	Behavior: Tape is rewound. If tape end is still detected 3 seconds later, cassette is ejected. Action: Reload the cassette.
58 1~ 58 2	BEGIN LEADER DETECTION	Tape beginning sensor abnormal.	Behavior: Tape is fast-forwarded. If tape begin is still detected 3 seconds later, cassette is ejected. Action: Reload the cassette.
70 1 (AUTO OFF)	DRUM MOTOR FAILURE	Drum stops motion.	Behavior: Stops, with no operation possible. Action: Turn the power off and then on.
71 1 (AUTO OFF)	CAPSTAN MOTOR FAILURE	Capstan stops its motion.	Behavior: Stops, with no operation possible. Action: Turn the power off and then on.
72 1~ 72 8 (AUTO OFF)	SUP REEL MOTOR FAILURE	Supply reel motor motion abnormal.	Behavior: Stops, with no operation possible. Action: Turn the power off and then on.
73 1~ 73 8 (AUTO OFF)	TU REEL MOTOR FAILURE	Takeup reel motor motion abnormal.	Behavior: Stops, with no operation possible. Action: Turn the power off and then on.

If there are any abnormalities when the self-diagnostics run after the power is turned on, the following warning indications are shown. Self-diagnostics are executed when menu switch No. 357 <DIAG AT POWER ON> is set to "ON". The warning code is shown in 6 digits. "x" mark shows unspecified.

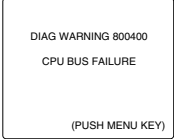
80xxxx	CPU BUS FAILURE	Signal communication between VCR's micro-processors abnormal.	Behavior: Only warning indicator is active. Action: Consult your local JVC dealer.  On-screen display  
820100 820300	EEPROM FAILURE	EEPROM signal communication in VCR abnormal.	
840100	SYSCON REF FAILURE	System controller reference signal failure.	
850100	M/S REF FAILURE	Mechanical controller reference signal failure.	
860100	TC REF FAILURE	Time code reference failure.	
C0xxxx	MECHA(NO TAPE) FAILURE	*1 Abnormal mechanical operation.	When the MENU button is pressed, the indication goes out.  * Serial digital signals are used in conformity with SMPTE259M for video and AES/EBU for audio.  *1 If the C02XXX indicator appears when the power is turned ON it means that condensation has occurred. Press the [MENU] button until the indicator goes out. Once the indicator has gone out, you can operate the unit as usual.

## 14 TROUBLESHOOTING

### 14-2 TROUBLES NOT TO BE WARNED BY INDICATORS

Symptoms	Cause	Action
Not operable	<ul style="list-style-type: none"> <li>The [REMOTE] button is set to "Remote".</li> <li>Menu switch No. 002 &lt;OPERATION LOCK &gt; set to "ON"</li> <li>Menu setting mode entered</li> </ul>	<ul style="list-style-type: none"> <li>Set [REMOTE] button to "LOCAL".</li> <li>Set Menu switch No. 002 &lt;OPERATION LOCK&gt; to "OFF".</li> <li>Press [MENU] button to restore normal mode.</li> </ul>
Not recordable	<ul style="list-style-type: none"> <li>Protective slider on the cassette not at "REC"</li> <li>Menu switch No. 351 &lt;PRE READ&gt; is set to "VID-ON" or "AUD-ON".</li> </ul>	<ul style="list-style-type: none"> <li>Set cassette's protective slider to "REC".</li> <li>Set menu switch No. 351 &lt;PRE READ&gt; to "OFF".</li> </ul>
Playback impossible	<ul style="list-style-type: none"> <li>S-VHS/VHS cassette in use</li> </ul>	<ul style="list-style-type: none"> <li>S-VHS/VHS cassette not acceptable</li> </ul>
On-screen display does not come up	<ul style="list-style-type: none"> <li>Monitor not connected to [LINE2-SUPER OUT]</li> <li>[ON SCREEN] switch on the sub panel set to OFF.</li> </ul>	<ul style="list-style-type: none"> <li>Connect monitor to [LINE2-SUPER OUT].</li> <li>Set [ON SCREEN] switch to ON.</li> </ul>
Noise appears on part of the playback picture.	<ul style="list-style-type: none"> <li>The heads are dirty.</li> <li>Menu switch No. 005 &lt;AUTO TRACKING&gt; set to "OFF".</li> <li>Menu switch No. 112 &lt;ECC MODE&gt; set to "NO CONCEAL" or "NO CORRECTION"</li> </ul>	<ul style="list-style-type: none"> <li>Clean the heads as instructed on page 11.</li> <li>Set menu switch No. 005 &lt;AUTO TRACKING&gt; to "ON".</li> <li>If noise appears when set to "ON", set to "OFF" and perform manual tracking adjustment.</li> <li>Set menu switch No. 112 &lt;ECC MODE&gt; to "NORMAL".</li> </ul>
Tape counter does not run.	<ul style="list-style-type: none"> <li>CTL counter does not run on a non-recorded section of the tape as no CTL signal is recorded on such a section.</li> <li>Counter is in Menu Switch Setting mode.</li> </ul>	<ul style="list-style-type: none"> <li>Press [MENU] button and enter Tape Counter mode.</li> </ul>
Menu setting cannot be changed.	<ul style="list-style-type: none"> <li>Menu switch No. 00D &lt;MENU LOCK&gt; is set to "ON".</li> </ul>	<ul style="list-style-type: none"> <li>Set menu switch No. 00D &lt;MENU LOCK&gt; to "OFF".</li> </ul>
Input signal cannot be switched.	<ul style="list-style-type: none"> <li>Menu switch No. 371 &lt;INPUT SELECT SAFETY&gt; is set to "ON".</li> <li>The optional SA-D95U digital interface board is not installed.</li> </ul>	<ul style="list-style-type: none"> <li>Set menu switch No. 371 &lt;INPUT SELECT SAFETY&gt; to "OFF" or press the signal switch while pressing the [SHIFT] button.</li> <li>Install the SA-D95U. Otherwise, digital signals cannot be selected.</li> </ul>
The Menu Switch Setting mode cannot be engaged.	<ul style="list-style-type: none"> <li>Menu switch No. 374 &lt;MENU OPEN SAFETY&gt; is set to "ON".</li> </ul>	<ul style="list-style-type: none"> <li>Set menu switch No. 374 &lt;MENU OPEN SAFETY&gt; to "OFF" or press the [MENU] button while pressing the [SHIFT] button.</li> </ul>
During playback, the on-screen sub time code indication does not advance.	<ul style="list-style-type: none"> <li>Menu switch No. 450 &lt;SUB TC (VITC) REC&gt; is set to "OFF" and menu switch No. 451 &lt;VITC OUT SELECT&gt; is set to "OFF" or "TC".</li> <li>Sub time code is not recorded normally.</li> </ul>	<ul style="list-style-type: none"> <li>Set menu switch No. 450 &lt;SUB TC (VITC) REC&gt; to "ON" or menu switch No. 451 &lt;VITC OUT SELECT&gt; to "SUB TC".</li> </ul>

# 15 APPENDIX

## 15-1 Operation Button Combinations

REC+PLAY	Starts recording
REC+HOLD	Starts recording current adjustment (top menu 00E)
SET+HOLD	Sets the top menu (00A — 00D) (SET)
PLAY+FF	1.07x playback
PLAY+REW	0.93x playback
PLAY+ jog dial	STILL — 2x playback
PLAY+ search dial	Variable playback (0.9x to 1.1x playback)
SEARCH+ jog dial	Changes menu switch setting value (menu switch setting) Changes time code data (time code setting) Changes fixed time data (top menu 00F)
STOP+STANDBY+REW+FF	Starts head cleaning (No tape)
SET+RESET	Registers counter memory point
SET+PREROLL	Starts counter search
SHIFT+PREROLL	Starts fixed time cue up
SHIFT+SEARCH	Variable mode (Only the player during swap editing)
IN+ENTRY	Registers the IN point
OUT+ENTRY	Registers the OUT point
IN+OUT	Duration display
IN+CANCEL	Cancels the IN point
OUT+CANCEL	Cancels the OUT point
IN+PREROLL	Cues the IN point
OUT+PREROLL	Cues the OUT point
IN+jog dial	Corrects the IN point
OUT+jog dial	Corrects the OUT point
IN+OUT+jog dial	Corrects the duration
SHIFT+IN+ENTRY	Registers the audio split point (IN point)
SHIFT+IN	Indicates the audio split point (IN point)
SHIFT+IN+jog dial	Corrects the audio split point (IN point)
SHIFT+IN+CANCEL	Cancels the audio split point (IN point)
SHIFT+PREVIEW	Review
SHIFT+AUTO EDIT	Last edit
SHIFT+input video signal or audio signal select button	Switches input signal when menu switch No.371 <INPUT SELECT SAFETY> is set to "ON".
SHIFT+MENU	Opens the menu switch setting display when menu switch No. 374 <MENU OPEN SAFETY> is set to "ON".
SHIFT+COUNTER	ON/OFF switching of the counter mode (user bits)
PLAYER+RECORDER	Recorder and player simultaneous operation mode
SHIFT+STANDBY	Switches the edit on-screen display ON/OFF
SHIFT+RECORDER	Activates the learn function
CANCEL+AUTO EDIT	To cancel the player and recorder edit points as well as the audio split point:
SHIFT+REC	Open the<STRIPING REC MENU>
SHIFT+P. PLAY	Program Playback mode
P. PLAY+PLAY	Starts the program playback.
P. PLAY+ jog dial	Sets the program playback speed.

## 15-2 OPTIONAL ACCESSORIES

### SA-D95U Digital Interface Board

Install in the BR-D95U. This is used to input and output video and audio digital signals.

### Rack Mount Adapter SA-K67

SA-K67 is a rack mount adapter used to mount this unit on a 19" EIA standard rack.

#### ■ Mount rail & bracket

When mounting the unit on a rack with the SA-K67, a mount rail and mount bracket are also required.

Recommended models:

- Acurdy Co., Ltd. 2038-22 (mount rail)  
BK2038 (bracket)

#### ■ Installation

1. Secure the rack mount adapter to the VCR with 6 M4 screws.
2. Secure the slide rail inner member to the VCR with 6 M4 screws.
3. Mount the slide rail outer members on the front and rear ends of the rack using the bracket.
4. Pull out the rails in the slide rail outer members until you hear a click.
5. Fit the right and left slide rails on the VCR into the pulled-out rails and push them in together. The rails will be blocked by right and left springs, so press the springs with your fingers and push the VCR further in.

#### Precautions

- Do not use screws 8 mm or longer to secure the rack mount adapter and slide rail inner members to the VCR, as doing so may damage the printed circuit boards inside the VCR.
- The handle on the rack mount adapter is only for sliding the VCR in and out. Do not lift the VCR with this handle.
- When installing the VCR in a rack, make sure there is sufficient clearance above and below the VCR for heat radiation.
- Some racks may require that you mount the slide rails in a particular way. If you have any questions, consult the rack dealer.

# 15 APPENDIX

## 15-3 INDEX

<b>A.</b>	Adjustment .....	118
	Assemble editing .....	104
	Audio emphasis .....	74
	Audio input connectors .....	19
	Audio input switch .....	24
	Audio monitor switch .....	14
	Audio output connectors .....	20
	Audio recording level .....	71
	Audio split editing .....	112
	Audio V. fade function .....	80
<b>C.</b>	Cassette tape .....	11
	Channel condition indicator .....	22
	Color frame servo setting .....	105
	Condensation .....	10
	Counter memory .....	86
	Counter switch .....	21
<b>D.</b>	Diagnosis connector .....	18
	Direct access .....	33
	Drop frame .....	98
	Dubbing loop function .....	122
<b>E.</b>	Editing system phase adjustment .....	117
	Error conceal .....	80
	Error correction .....	80
	Extra line playback .....	88
	Extra line recording .....	87
<b>F.</b>	Fine meter mode button .....	13
	Fixed time cue up function .....	91
<b>H.</b>	Head cleaning .....	11
	Hour meter .....	39
<b>I.</b>	Insert editing .....	104
<b>L.</b>	Last edit .....	113
<b>M.</b>	Main code .....	101
	Masking setting .....	64
	Match frame .....	58
	Meter mode setting button .....	15
	Menu switch list .....	40
	Menu switch setting .....	28
	Menu switch setting button .....	15
	Menu switch setting contents .....	43
	Monitor output connector section .....	26
	Motion memory function .....	114
	Mute/alarm condition display .....	24
	Multi cue-up function .....	92
<b>N.</b>	Non-drop frame .....	97
<b>O.</b>	Optional equipment .....	148
	Operation buttons .....	12
	Operation mode lock .....	65
<b>P.</b>	Power switch .....	12
	Pre-read function .....	115
	Preview switcher .....	116
	Program playback .....	85
<b>R.</b>	Recording current adjustment .....	38
	Reference sync signal .....	25
	Remote connector .....	10
	Remote button .....	14
	Repeat playback .....	86
<b>S.</b>	Search/jog dial .....	13
	Simplified playback speed adjustment function .....	81
	Simultaneous operation .....	90
	Slow play .....	24
	Standby ON/OFF .....	16
	Striping rec function .....	94
	Subcarrier phase adjustment .....	121
	Sub code .....	102
	Sub time code display .....	96
	Sub time code playback .....	102
	Sub time code recording .....	102
	Swap editing .....	107
	Synchronized running mode .....	81
<b>T.</b>	Time code display .....	96
	Time code generator setting buttons .....	18
	Time code playback .....	101
	Time code presetting .....	97
	Time code recording .....	99
	Time code setting switch section .....	18
	Top menu .....	28
<b>U.</b>	User page .....	34
	User bit auto preset function .....	63
<b>V.</b>	Variable-motion editing .....	113
	Variable slow playback .....	83
	Video control connector .....	27
	Video input connectors .....	25
	Video input switch .....	14
	Video phase adjustment .....	118
<b>W.</b>	Warning .....	145

# 16 SPECIFICATIONS

● General		
Format	Type D-9 (Digital S)	
Tape width	12.65 mm	
Tape speed	57.737 mm/sec. (525), 57.795 mm/s (625)	
Signal format	NTSC standard (525), PAL standard (625)	
Dimensions	429 mm (W) x 189 mm (H) x 569 mm (D) (16-15/16" x 7-1/2" x 22-7/16")	
Weight	Approx. 22 kg (48.5 lbs.)	
Power consumption	Approx. 1.7 A to 0.8 A	
Power supply	AC 110 V to 240 V ~, 50 Hz/60 Hz	
Record/play time (w/DS-104)	(Record/play) Approx. 104 min.	
REW/FF time (w/DS-104)	Approx. 3 min.	
Operating temperature	5°C to 40°C (41°F to 104°F)	
Storage temperature	-20°C to 60°C (-4°F to 140°F)	
Operating humidity	30% to 80%RH	
● Video signal		
Input	Composite	1 Vp-p, 75 ohms, unbalanced
	Component	Y: 1 Vp-p/R-Y, B-Y, 0.7 Vp-p, 75 ohms, unbalanced
Output	Composite	1 Vp-p, 75 ohms, unbalanced
	Component	Y: 1 Vp-p/R-Y, B-Y, 0.7 Vp-p, 75 ohms, unbalanced
External input	0.43 Vp-p (B.B) (525), 0.45 Vp-p (B.B) (625), 75 ohms, unbalanced	
Sampling frequency	Y: 13.5 MHz, R-Y/B-Y: 6.75 MHz	
Quantization	8 bits	
Frequency range	Y: 0 - 5.75 MHz, +1.0 dB/-3.0 dB (analog component in/out) R-Y/B-Y: 0 - 2.75 MHz, +1.0 dB/-3.0 dB	
S/N	More than 50 dB (analog composite in/out) More than 55 dB (analog component in/out) More than 60 dB (digital in/analog component out)	
● Audio signal		
Input	Line input	-20/-6/0/+4 dBs, high impedance, balanced
	Headphone	-∞ to -14 dBs, 8 ohms
Output	Line output	-6/0/+4 dBs, low impedance, balanced
	Monitor output	-6/0/+4 dBs, low impedance, balanced
Sampling frequency	48 kHz	
Quantization	16 bits	
No. of channels	4	
Frequency response	20 Hz to 20 kHz	
Dynamic range	85 dB or more	
Wow & flutter	Below a measurable value	
● Time code		
LTC input	0 ± 6 dBs, high impedance, balanced	
LTC output	0 ± 3 dBs, low impedance, balanced	
● Accessories		
Power cable (A Type: 125 V, 7 A / C Type: 250 V, 10 A) Repeat Tye x 1		
● When the optional SA-D95U is installed		
Serial video/audio input	Conforming to SMPTE259M/CCIR656-III	
Serial video/audio output	Conforming to SMPTE259M/CCIR656-III, 800 mVp-p ± 10%	
Digital audio input	1 Vp-p, 75 ohms, unbalanced, conforms to AES/EBU standard	
Digital audio output	1 Vp-p/3 Vp-p or more (switchable with built-in switch), 75 ohms, unbalanced, conforms to AES/EBU standard	

Design and specifications subject to change without notice.

# 16 SPECIFICATIONS

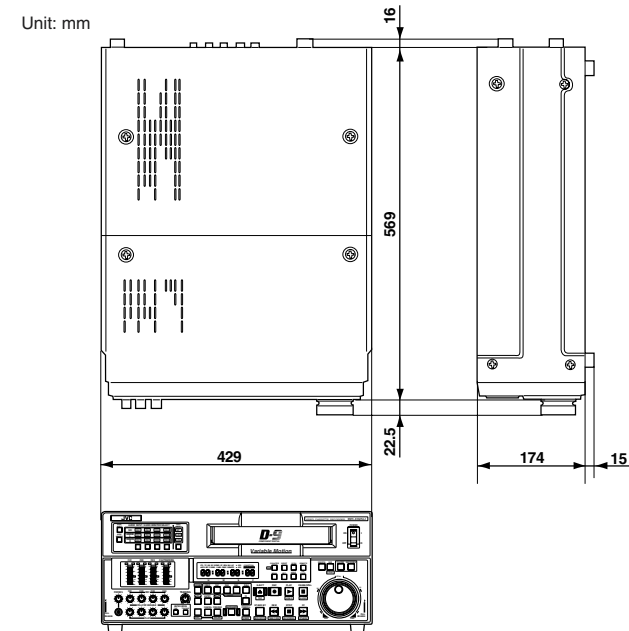

Design and specifications subject to change without notice.

## Free Manuals Download Website

<http://myh66.com>

<http://usermanuals.us>

<http://www.somanuals.com>

<http://www.4manuals.cc>

<http://www.manual-lib.com>

<http://www.404manual.com>

<http://www.luxmanual.com>

<http://aubethermostatmanual.com>

Golf course search by state

<http://golfingnear.com>

Email search by domain

<http://emailbydomain.com>

Auto manuals search

<http://auto.somanuals.com>

TV manuals search

<http://tv.somanuals.com>