

KAMBROOK

THE SMARTER CHOICE



Rice
Express 8
KRC8

Instruction Booklet

Important

Please retain your instruction book for future use.

In the event that you need some assistance with your Kambrook appliance, please contact our Customer Service Department on 1300 139 798 (Australia) or 0800 273845 (New Zealand). Alternatively, visit us on our website at www.kambrook.com.au or www.kambrook.co.nz

Contents

Kambrook Recommends Safety First	p4
Your Rice Express 8 Rice Cooker	p6
Using Your Rice Cooker	p7
Rice Cooking Guide	p9
Care and Cleaning	p13
Recipes	p14

Kambrook Recommends Safety First

IMPORTANT: Please retain your instruction book for future use.

At Kambrook, we believe that safe performance is the first priority in any consumer product, so that you, our valued customer, can confidently use and trust our products. We ask that any electrical appliance that you use be operated in a sensible fashion with due care and attention placed on the following important operating instructions.

Important Safeguards For Your Kambrook Rice Express 8 Rice Cooker

- Carefully read all instructions before operating the Rice Cooker for the first time and save for future reference.
- Remove and safely discard any packaging material and promotional labels before using the Rice Cooker for the first time.
- To eliminate a choking hazard for young children, remove and safely discard the protective cover fitted to the power plug of this appliance.
- Do not place the appliance near the edge of a bench or table during operation.
- Ensure the surface is level, clean and free of water and other substances.
- Do not operate the Rice Cooker on a sink drain board.
- Do not place this appliance on or near a hot gas or electric burner, or where it could touch a heated oven.
- Position the Rice Cooker at a minimum distance of 20cm away from walls and provide adequate space above and all sides for air circulation.
- Always operate the Rice Cooker on a stable and heat resistant surface.
- Use the removable cooking bowl supplied with the Rice Cooker. Do not use any other bowl inside the housing.
- Do not use a damaged or dented removable cooking bowl. If damaged or dented, replace bowl before using.
- Never plug in or switch on the Rice Cooker without having the removable cooking bowl placed inside the stainless steel housing.
- Do not place food or liquid in the housing.
- Only the removable cooking bowl is designed to contain food or liquid.
- Always ensure the Rice Cooker is properly assembled before operating. Follow the instructions provided in this book.
- Never operate the Rice Cooker without food and liquid in the removable cooking bowl.
- Do not touch hot surfaces, use oven mitts to remove the lid. Lift and remove the lid carefully to avoid scalding from escaping steam.
- Do not allow water from the lid to drip into the housing, only into the removable cooking bowl.
- Always have the lid locked correctly into position on the Rice Cooker throughout operation of the appliance unless states in the recipe to have it removed.
- The glass lid has been specially treated to make it stronger, more durable and safer than ordinary glass, however its is not unbreakable. If struck extremely hard, it may break or weaken and could at a later time shatter into many small pieces without apparent cause.
- Do not touch hot surfaces; use oven mitts to remove the removable cooking bowl and steaming tray.

- Always ensure the power is switched off at the power outlet and the power cord is unplugged from the power outlet before attempting to move the appliance, when not in use and before cleaning or storing.
- Allow all parts to cool before disassembling for cleaning.
- Extreme caution must be used when the appliance contains hot food and liquids. Do not move the appliance during cooking.
- The Rice Cooker is not intended to be operated by means of an external timer or separate remote control system.
- Do not leave the Rice Cooker unattended when in use.
- Do not place anything, other than the locking lid, on top of the Rice Cooker when assembled, when in use and when stored.
- Keep the Rice Cooker clean. Follow the cleaning instructions provided in this book.

Important Safeguards For All Electrical Appliances

- Carefully read all instructions before operating the appliance and save for future reference.
- Remove and safely discard all packaging material and promotional labels before using the appliance for the first time.
- Fully unwind the power cord before use.
- Do not let the power cord hang over the edge of a bench or table, touch hot surfaces or become knotted.
- To protect against electric shock, do not immerse the power cord, power plug or appliance in water or any other liquid, unless it is recommended in the cleaning instructions.
- The appliance is not intended for use by persons (including children) with reduced physical, sensory or mental capabilities, or lack of experience and knowledge, unless they have been given supervision or instruction concerning use of the appliance, by a person responsible for their safety.
- Children should be supervised to ensure that they do not play with the appliance.
- It is recommended to inspect the appliance regularly. Do not use the appliance if the power supply cord, plug, connector or appliance becomes damaged in anyway. Return the entire appliance to the nearest authorised Kambrook Service Centre for examination and/or repair.
- Any maintenance other than cleaning should be performed at an authorised Kambrook Service Centre.
- This appliance is for household use only. Do not use this appliance for other than its intended use. Do not use in moving vehicles or boats. Do not use outdoors. **Misuse may cause injury.**
- The installation of a residual current device (safety switch) is recommended to provide additional safety protection when using electrical appliances. It is advisable that a safety switch with a rated residual operating current not exceeding 30mA be installed in the electrical circuit supplying the appliance. See your electrician for professional advice
- Always turn the appliance to the OFF position, switch off at the power outlet and unplug at the power outlet when the appliance is not in use.
- Before cleaning, always turn the appliance to the OFF position, switch off at the power outlet, unplug at the power outlet and remove the power cord, if detachable, from the appliance and allow all parts to cool.
- Do not place this appliance on or near a heat source, such as hot plate, oven or heaters.
- Position the appliance at a minimum distance of 20cm away from walls, curtains and other heat or steam sensitive materials and provide adequate space above and on all sides for air circulation.



WARNING: Fully unwind the cord before use.



WARNING: Ensure appliance is fully cooled before storing.



WARNING: Hot surfaces during and after use.

Your Rice Express 8 Rice Cooker

1. Rice cooker with 8 cup capacity
2. Easy clean non-stick removable cooking bowl
3. Glass lid with stainless steel rim which allows you to look at the rice while cooking
4. Cool touch handles
5. Cooking indicator light - the red light indicates that your rice cooker is on the 'COOK' setting.
6. Keep 'WARM' indicator light - the amber light indicates that your rice cooker is 'ON' and has automatically switched to the keep 'WARM' setting.
7. Cooking control lever – press the lever down to commence cooking. The lever will automatically switch up to the 'WARM' setting when the rice is cooked.
8. Steaming rack
9. Rice Express 8 measuring cup
10. Serving spoon



Using Your Rice Cooker

Before First Use

Remove any packaging or promotional labels and wash the removable cooking bowl, steaming rack, glass lid, measuring cup and serving spoon in warm soapy water, rinse and dry thoroughly.

Do not immerse the cord or cooking body in water or any other liquid.

Remove the removable cooking bowl. Using the measuring cup provided, measure out the required amount of rice and place into the removable cooking bowl.

Wash the rice in the cooking bowl with cold water, drain this water from the rice, and continue this process until the water appears clear. Add the required amount of cold tap water.

Please refer to the Rice Cooking Guide on page 9 for quantities. Thoroughly dry the removable cooking bowl exterior.

NOTE: When measuring rice use the measuring cup provided and level off. (Fig. 1)

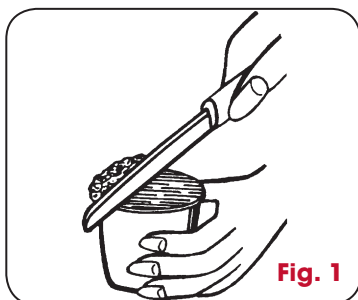

Fig. 1

NOTE: The minimum quantity of uncooked white rice that can be cooked in the rice cooker is 1 Rice Express measuring cup (as included).

Place the removable cooking bowl into the cooking body.

Place the glass lid into position on top of the removable cooking bowl.

Plug the appliance into a 230V or 240V power point and switch on.

To begin cooking, push the cooking lever down. The cooking indicator light will illuminate (red).

NOTE: There will only be one light on at a time, red for the 'COOK' setting and amber for the keep 'WARM' setting.

When cooking is completed, the rice cooker will automatically switch to the 'WARM' setting and the amber 'WARM' indicator light will illuminate.

When the rice finishes cooking and switches to the 'WARM' setting, lift the glass lid and gently stir the rice using the serving spoon.

For extra soft rice or to absorb any excess moisture, replace the lid and allow to sit on the 'WARM' setting for 10-15 minutes.

Once cooked, the rice can be kept on the 'WARM' setting for up to 5 hours, without losing its taste. However, when cooking 1 cup of rice, if left on the 'WARM' setting, the rice will become dry.

Using Your Rice Cooker continued



WARNING: Always lift the glass lid away from you to avoid steam scalding.

Switch off at the power outlet and then unplug. Use oven mitts to remove the removable cooking bowl to serve. Allow the rice cooker to cool down before cleaning.

NOTE: To stop the automatic keep 'WARM' setting, simply switch off at the power point and then unplug.

Do not interfere with the automatic cooking control lever during the operation.

Always ensure rice is spread evenly across the bottom of the removable cooking bowl and not heaped to one side (Fig. 2).

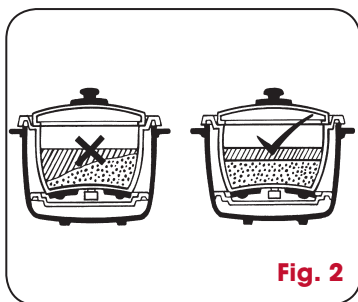

Fig. 2



WARNING: To avoid damage to your appliance always ensure that the removable cooking bowl is correctly positioned in the unit and pressed down firmly. (Fig. 3).

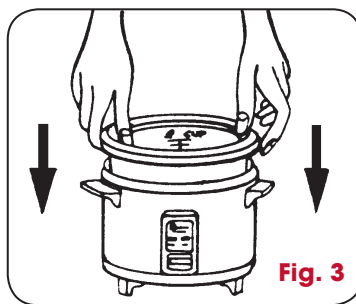

Fig. 3

Do not use a damaged or dented cooking bowl as this may cause the cooking bowl to sit inside the rice cooker incorrectly.

NOTE: Never use metal utensils inside the removable cooking bowl as they will damage the non-stick surface.

Rice Cooking Guide

NOTE: The rice cooker rice measuring cup = 180ml. If you misplace the rice measuring cup, any cup including a standard metric cup can be used, but it is important that the ratios are abided to. Do not leave the rice cooker on the 'WARM' cycle for longer than 5 hours.

The quantity of water used will depend on the age and strain of the rice, as well as personal taste.

Rice Cooking Tables

White Rice Cooking Tables

Quantity of uncooked White Rice (Rice Express 8 measuring cup)	Cups of water (cold tap water)	Approx Number of 1 cup servings of cooked rice (Rice Express measuring cup)
2 cups	2 cups	5
4 cups	4 cups	10
6 cups	6 cups	15
8 cups	8 cups	20

Brown Rice Cooking Tables

Quantity of uncooked Brown Rice (Rice Express 8 measuring cup)	Cups of water (cold tap water)	Approx Number of 1 cup servings of cooked rice (Rice Express measuring cup)
2 cups	3 cups	5
4 cups	6 cups	10
6 cups	9 cups	15

Steaming

Steamed food retains most of its nutritional value. Food may be steamed by placing it on the steaming tray over stock or water and covering with the glass lid. Keep the glass lid on while steaming unless the recipe or chart specifically calls for removing the lid. By removing the lid unnecessarily, you lose steam and valuable time.

1. Place 3 rice measuring cups or more of water or stock into the removable cooking bowl
2. Place food to be steamed directly onto the steaming tray and insert into the removable cooking bowl. (Refer to the steaming charts on pages 11 and 12 for approximate cooking times).

Rice Cooking Guide continued

- Place the removable cooking bowl with steaming tray into the cooking body and cover with the glass lid.
 - Plug into a 230V or 240V power outlet and then switch on. The amber 'WARM' light will illuminate.
 - Push the selector lever down to begin to cook. The red 'COOK' light will illuminate.
 - When cooking is complete, remove food.
- Fresh or frozen vegetables may be steamed.
 - If steaming frozen vegetables, do not thaw first.
 - Do not allow water or stock to touch the tray or food.
 - Check liquid level occasionally. Add more hot water if further steaming is required.
 - Always lift the lid away from you to avoid the spurt of steam escaping from under the lid.

NOTE: There will only be one light on at a time ie amber for 'Warming' or red for 'Cooking'

If further cooking is required, ensure sufficient water or stock is in the removable cooking bowl.

- When finished cooking, turn the rice cooker off at the power outlet and then unplug. Then remove the steaming tray and serve. Allow the rice cooker to cool before cleaning.



WARNING: Always lift the lid away from you to avoid the head of the steam escaping from under the lid.

Hints and Tips for Steaming Vegetables

- Smaller pieces will steam faster than larger ones.
- Try to keep vegetables to a standard size to ensure even cooking.
- Ensure that not all the steamer holes are covered by food to prevent overflow during steaming.

Hints and Tips for Steaming Fish and Seafood

- Season fish with fresh herbs, onions, lemon etc.
- Ensure fish fillets are in a single layer and not overlapped.
- Fish is cooked when it flakes easily with a fork and is opaque in colour.

Hints and Tips for Steaming Poultry

- Select pieces of poultry of a similar size for even cooking.
- Arrange a single layer if possible, to facilitate even cooking.
- Remove visible fat and skin.
- Check poultry is cooked by piercing the thickest part of the poultry. If the juices run clear it is cooked.

Vegetables

The size and shape of vegetables may call for adjustments. If you want softer vegetables, allow extra cooking time.



WARNING: Do not allow the removable cooking bowl to boil dry.

Vegetables	Preparation & Tips	Quantity	Cooking Time
Artichoke	remove the hard outer leaves and stalk	2 medium	30-35 mins
Asparagus	trim, leave in spears	1 bunch	12-14 mins
Beans	top and tail, leave whole	250gm	13-15 mins
Beetroot small-medium	trim, do not break skin	3 pieces	12-13 mins
Broccoli	cut into florets	250gm	8-10 mins
Brussel Sprouts	cut a cross in the base	375gm	17-19 mins
Cabbage	large pieces	500gm	10-12 mins
Carrots	1.25cm slices	2 medium	14-16 mins
Capsicums	cut into strips	2 medium	14-16 mins
Cauliflower	cut into florets	375gm	17-19 mins
Celery	slice into strips	2 stalk	5-6 mins
Corn	whole corn cobs	2 small ears	15-17 mins
Mushrooms	whole, unwashed	300gm	8-10 mins
Onions (cocktail)	peeled, leave whole	6 small	20-25 mins
Snowpeas	Top and tailed	250gm	4-5 mins
Potatoes	all purpose whole	4 (150-180gm ea)	35-40 mins
Potatoes	new whole potatoes	6 (125gm ea)	25-30 mins
Pumpkin	cut into pieces	500gm	20-25 mins
Spinach (English)	leaves & stems cleaned	½ bunch	5 mins
Squash (baby)	top and tail	350gm	8 mins
Turnips	peeled, sliced and cut to 50gm pieces	350gm	15-17 mins
Zucchini	sliced	350gm	6 mins

Rice Cooking Guide continued

Fish and Seafood

Type	Time	Suggestions and Tips
Fish – fillets - whole - cutlets	8-10 mins 15-20 mins 12-14 mins	Steam until opaque and easy to flake
Lobster – tails	18-20 mins	Remove underside of shell
Mussels – in shell	12-14 mins	Steam until well open
Prawns – in shell	8-10 mins	Steam until pink
Scallops	4-6 mins	Steam until opaque

Poultry

Type	Time	Suggestions and Tips
Breast Fillet	20-25 mins	Place flesh side down
Drumstick	30-35 mins	Place thickest part to outside of stainless steel steaming tray
Thigh Fillet	18-20 mins	Place thickest part to outside of stainless steel steaming tray 18-20 mins

Care and Cleaning

Switch off at the power point and then unplug. Allow all parts to cool before cleaning. Wash removable cooking bowl, steaming tray, glass lid, serving spoon and measuring cup in warm soapy water, rinse and dry all parts thoroughly.

Do not wash the removable cooking bowl, steaming tray, measuring cup or cooker body in a dishwasher.

Do not use abrasive cleaners, steel wool or scouring pads as these can damage the non-stick surface inside the removable cooking bowl or scratch the cooking body surface.

Never use metal utensils inside the non-stick removable cooking bowl.

NOTE: If rice has cooked onto the bottom of the removable cooking bowl, fill the bowl with hot soapy water and leave to stand for approximately 10 minutes before cleaning.

The cooking body can simply be wiped over with a damp cloth and then dried.



WARNING: Do not immerse cooking body, power cord or plug in water or any other liquid as this may cause electrocution.

Recipes

NOTE: Metric cups have been used in all recipes.

Chicken & Basil Risotto

Serves 6

- 1 ½ tablespoons olive oil
- 1 spanish onion, finely chopped
- 2 cloves garlic, minced
- 2 cups arborio rice, washed
- 3 ½ cups chicken stock
- 2 chicken breasts, grilled and thinly sliced
- 2 tomatoes, diced
- ¾ cup parmesan cheese, grated
- 2 tablespoons basil leaves, shredded

1. Place oil, onion and garlic into the removable cooking bowl of the rice cooker and place the glass lid on.
2. Press the selector control lever down to 'COOK' setting. Cook for 4 minutes.
3. Add rice and cook for a further 2 minutes.
4. Add the stock. Cook with the lid on for 20 minutes, stirring every 5 minutes.
5. Switch the cooking control lever to 'WARM' and add chicken, tomato, parmesan and basil. Allow to stand for 6 minutes.
6. Serve with parmesan cheese and basil leaves.

Tomato & Zucchini Risotto

Serves 6

- 1 ½ tablespoons olive oil
- 1 cup leek, thinly sliced
- 2 cloves garlic, minced
- 1 ½ cups arborio rice, washed
- 5 tomatoes, diced
- ¾ cup dry white wine
- 3 ½ cups chicken stock
- ¾ cup parmesan cheese, grated
- ¾ cup zucchini, grated
- 3 tablespoons pine nuts, toasted

1. Place oil, leek and garlic into the removable cooking bowl of the rice cooker and place the glass lid on.
2. Press the selector control lever down to 'COOK' setting. Cook for 4 minutes.
3. Add rice and cook for a further 2 minutes.
4. Add the tomato, wine and stock. Cook with the lid on for 20 minutes, stirring every 5 minutes.
5. Switch the cooking control lever to 'WARM' and add parmesan, zucchini and pine nuts. Allow to stand for 5 minutes.
6. Serve with parmesan cheese and pine nuts.

Risotto of Smoked Chicken and Eggplant

Serves 6

50gm butter
1 cup leek, thinly sliced
2 cloves garlic, minced
2 cups arborio rice, washed
½ cup capsicum, diced
4 cups chicken stock
1 teaspoon turmeric
1 teaspoon lime rind
200gm roasted eggplant, chopped
300gm smoked chicken breast, sliced

1. Place butter, leek and garlic into the removable cooking bowl of the rice cooker and place the glass lid on.
2. Press the selector control lever down to 'COOK' setting. Cook for 4 minutes.
3. Add rice and cook for a further 2 minutes.
4. Add the capsicum, stock, turmeric and rind. Cook with the lid on for 20 minutes, stirring every 5 minutes.
5. Switch the cooking control lever to 'WARM' and add eggplant and chicken. Allow to stand for 6 minutes.
6. Serve with fresh basil leaves and cracked pepper.

Rich Cheesy Risotto

Serves 6

40gm butter
1 spanish onion, finely diced
2 cloves garlic, minced
2 cups arborio rice, washed
4 cups vegetable stock
1 teaspoon lemon rind
½ cup swiss cheese, grated
½ cup romano cheese, grated
2 tablespoons garlic chives, thinly sliced

1. Place butter, onion and garlic into the removable cooking bowl of the rice cooker and place the glass lid on.
2. Press the selector control lever down to 'COOK' setting. Cook for 4 minutes.
3. Add rice and cook for a further 2 minutes.
4. Add the stock and lemon rind. Cook with the lid on for 20 minutes, stirring every 5 minutes.
5. Switch the cooking control lever to 'WARM' and add cheeses and allow to stand for 6 minutes.
6. Serve with garlic chives and sea salt.

Recipes continued

Sushi Rice

2 cups sushi rice, washed
2¼ cups water
1½ tablespoons rice vinegar
1½ tablespoons caster sugar
½ teaspoon salt

1. Place rice and water into the removable cooking bowl of the rice cooker. (thoroughly wash rice first).
2. Press the selector control lever down to 'COOK' setting. Cook with the lid on, until the rice cooker automatically switches to the 'WARM' setting. Stir once during cooking.
3. Stir through vinegar, sugar and salt with the serving spoon.
4. Allow to cool and then prepare sushi.

Sushi Rice Suggestions

- Seaweed Rolls

6 sheets of Nori seaweed
Sushi Rice
Wasabi paste, to taste
150gm smoked salmon, thinly sliced
Japanese pickled ginger and vegetables
Finely sliced cucumber or spring onion

1. Place a sheet of seaweed, shiny side down on a sheet of baking paper.
2. Spread a portion of the rice over a third of the nori sheet, leaving a border.
3. Spread a very thin layer of wasabi paste in a narrow line down the centre of the rice. Top with a thin strip of salmon then some pickled ginger and vegetables, cucumber or spring onion.
4. Using the paper as a guide roll up the seaweed to enclose the filling. Press to seal the edges.
5. Using a very sharp knife cut the roll neatly into 2.5cm pieces.
6. Repeat with remaining seaweed and filling. Chill until ready to serve.

TIP: Any leftover Sushi Rice can be frozen.

Turkish Pilaf

Serves 6

60gm ghee
½ spanish onion, diced
1 clove garlic, minced
½ teaspoon cardamom, ground
1 teaspoon cumin, ground
½ teaspoon turmeric
½ teaspoon salt
1 bay leaf
3 cups basmati rice, washed
3 cups chicken stock
fresh coriander

1. Place ghee, onion, garlic and all spices into the removable cooking bowl of the rice cooker and place the glass lid on.
2. Press the selector control lever down to 'COOK' setting. Cook for 4 minutes.
3. Add rice and stock and cook with the lid on for 20 minutes, stirring every 5 minutes.
4. Switch the cooking control lever to 'WARM'.
5. Serve with fresh coriander.

Spicy Rice

Serve 6

2 cups long grain white rice
2 cups water
1 cinnamon stick
2 cardamom pods
¼ teaspoon coriander seeds
1 whole clove
2 tablespoons orange juice
2 teaspoons lemon rind
2 tablespoons mint, finely chopped
150g pistachio nuts, shelled

1. Place rice, water, spices, juice and rind into the removable cooking bowl of the rice cooker and place the glass lid on.
2. Press the selector control lever down to 'COOK' setting. Cook for 20 minutes, stirring every 5 minutes
3. Switch the cooking control lever to 'WARM'.
4. Serve with fresh mint and pistachio nuts.

Kambook - Australia

Building 2, Port Air Industrial Estate
1A Hale Street
Botany NSW 2019
Australia
Customer Service Line 1300 139 798
Customer Service Fax 1800 621 337

www.kambook.com.au

Kambook - New Zealand

Private Bag 94411
Botany, Manukau
Auckland 2163
New Zealand
Customer Service Line/
Spare Parts 0800 273 845
Customer Service Fax 0800 288 513

www.kambook.co.nz

KAMBROOK
THE SMARTER CHOICE

Due to continual improvement in design or otherwise, the product you purchase may differ slightly from the illustration in this book. Issue B11

Free Manuals Download Website

<http://myh66.com>

<http://usermanuals.us>

<http://www.somanuals.com>

<http://www.4manuals.cc>

<http://www.manual-lib.com>

<http://www.404manual.com>

<http://www.luxmanual.com>

<http://aubethermostatmanual.com>

Golf course search by state

<http://golfingnear.com>

Email search by domain

<http://emailbydomain.com>

Auto manuals search

<http://auto.somanuals.com>

TV manuals search

<http://tv.somanuals.com>