

## KMR 1250 BAT

1.091-101

1.091-111

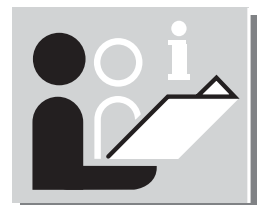
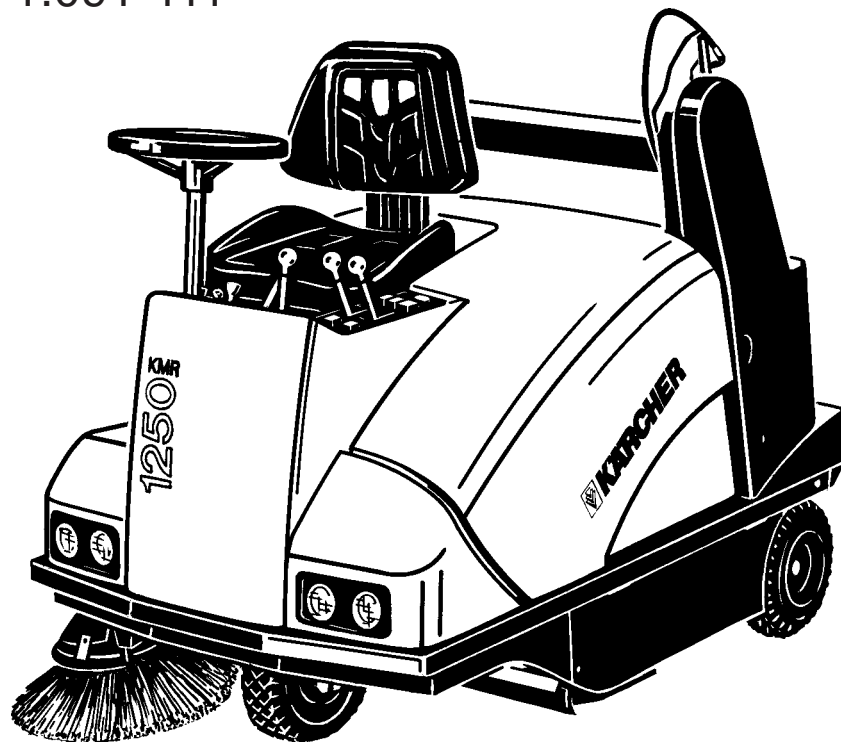

Deutsch

1–12

Lesen Sie vor der Inbetriebnahme diese Betriebsanleitung und beachten Sie besonders die "**Sicherheitshinweise**".

English

13–24

Please read these operating instructions before starting and strictly observe the "**Safety Instructions**".

Français

25–36

Veillez lire attentivement la présente notice d'instructions avant la mise en service et respecter en particulier les "**Consignes de sécurité**".

Italiano

37–48

Leggere queste istruzioni per l'uso prima della messa in esercizio facendo particolarmente "**Istruzioni per la sicurezza**".

Nederlands

49–60

Lees voor de ingebruikneming deze gebruikshandleiding en neem in het bijzonder de "**Veiligheidsvoorschriften**" in acht.

Español

61–72

Antes de poner en marcha el aparato deberá estudiar atentamente las "**Advertencias y observaciones relativas a la seguridad**".

Português

73–84

Antes da primeira utilização do aparelho leia este manual de utilização e tenha em especial atenção a brochura anexa "**Conselhos de segurança**".

Ελληνικά

85–96

Πριν θέσετε τη συσκευή για πρώτη φορά σε λειτουργία, διαβάστε τις παρούσες οδηγίες χειρισμού και τηρείτε ιδιαίτερα τις "**Υποδείξεις ασφαλείας**".

Dansk

97–108

De bedes læse denne driftsvejledning igennem før idrifttagningen i denne forbindelse skal især "**Sikkerhedsforskrifter**" overholdes.

Norsk

109–120

Før ibruktaking må bruksanvisningen leses nøye og det må taes hensyn til "**Sikkerhetsregler**".

Svenska

121–132

Läs igenom bruksanvisningen före driftstart och uppmärksamma "**Säkerhetsanvisningar**" extra noga.

Suomi

133–144

Lue ennen käyttöönottoa tämä käyttöohje huolellisesti läpi ja kiinnitä erikoista huomiota "**Turvallisuusohjeisiin**".

Polski

145–156

Jeszcze przed pierwszym użyciem urządzenia przeczytać tę „Instrukcję obsługi” i „**Wskazówki bezpieczeństwa**” i przestrzegać podanych w nich warunków!

## ■ Contents

|  |    |
|--|----|
| ■ IMPORTANT INFORMATION .....  | 13 |
| ■ For your safety .....  | 13 |
| ■ Risk of explosion when charging the battery .....                            | 13 |
| ■ Take care when handling the battery! .....                                   | 13 |
| ■ The sweeper can topple over when travelling or turning on steep slopes. .... | 13 |
| ■ Risk of sweeper toppling over when negotiating turns quickly! .....          | 13 |
| ■ Precautions to take when doing repair and maintenance .....                  | 13 |
| ■ On behalf of the environment .....   | 13 |
| ■ General data .....   | 14 |
| ■ Precautions to take when transporting the sweeper ....                       | 14 |
| ■ Intended usage .....   | 14 |
| ■ Function of the main components .....  | 14 |
| ■ OPERATING CONTROLS .....   | 15 |
| ■ PRIOR TO INITIAL START-UP .....  | 16 |
| ■ Directions for unloading .....   | 16 |
| ■ Pushing the sweeper by hand .....  | 16 |
| ■ After sweeper has been moved by hand: .....                                  | 16 |
| ■ PRIOR TO EVERY START-UP .....  | 16 |
| ■ STARTING THE SWEEPER .....   | 16 |
| ■ Adjusting the driver's seat .....  | 16 |
| ■ Initial driving trials .....   | 16 |
| ■ Working with the sweeper .....   | 17 |
| ■ Braking .....  | 17 |
| ■ Going up slopes .....  | 17 |
| ■ Stopping the sweeper and switching off .....                                 | 17 |
| ■ Cleaning the filter .....  | 17 |
| ■ Emptying the waste hopper .....  | 17 |
| ■ TYPICAL APPLICATIONS .....   | 18 |
| ■ Picking up larger items (sticks, tins, etc.) .....                           | 18 |
| ■ Overcoming obstacles .....   | 18 |
| ■ BATTERY .....  | 19 |
| ■ Checking the level of electrolyte in the battery .....                       | 19 |
| ■ Charging the battery .....   | 19 |
| ■ MAINTENANCE .....  | 20 |
| ■ Initial inspection after 8 operating hours .....                             | 20 |
| ■ Daily maintenance .....  | 20 |
| ■ Maintenance intervals .....  | 20 |
| ■ Maintenance tasks .....  | 20 |
| ■ Checking the hydraulic system .....  | 20 |
| ■ Replacing the sealing skirts .....   | 20 |
| ■ Replacing the side brush .....   | 20 |
| ■ Adjusting the sweeping pattern .....   | 21 |
| ■ Replacing the main brush roller .....  | 21 |
| ■ Replacing fuses .....  | 22 |
| ■ Replacing the dust filters .....   | 22 |
| ■ TECHNICAL DATA .....   | 23 |
| ■ TROUBLESHOOTING .....  | 24 |

## ■ IMPORTANT INFORMATION



### ■ For your safety

Before using the machine for the first time, read these user instructions and the appended booklet **"Safety Information 5.956-250"**.

Please note carefully all the information contained in them.

### ■ Risk of explosion when charging the battery

When low-maintenance batteries are being charged, explosive gases are given off. Each time the battery is charged open the cover of the sweeper and make sure there is sufficient ventilation. Do not smoke and make sure there is no naked flame. For further information, see chapter "Battery".

### ■ Take care when handling the battery!

Observe the information on safety provided by the battery manufacturer. The right to claim under the warranty exists only if you are using Kärcher recommended batteries and battery chargers.

### ■ Risk of sweeper toppling over when slope too great!

The sweeper can topple over when travelling or turning on steep slopes.

- If you are working in the direction of motion, only attempt slopes of up to 18 % gradient
- If you are working across the direction of motion, only attempt slopes of up to 10 % gradient

### ■ Risk of sweeper toppling over when negotiating turns quickly!

The sweeper can topple over if turns are negotiated quickly. Make slow turns.

### ■ Precautions to take when doing repair and maintenance

To avoid the sweeper being started unintentionally, proceed as follows after switching the sweeper off:

- Remove starting key
- Pull out battery plug connection

### ■ On behalf of the environment

#### **Caution! Used batteries are a danger to the environment!**

Used batteries do not belong in the household rubbish. See that they are disposed of in a way that will cause no harm to the environment.

#### **Caution! Hydraulic fluid is a danger to the environment!**

When you change the oil, hand in the used oil at a used-oil collection point or to a disposal firm.

## ■ General data

The sweeper is designed for 24 V direct current. It has been provided with a 24 V trough battery (supplied with the 1.091-111). In the case of other machines, the battery and its appropriate charger must be obtained separately.

Your Kärcher dealer will be pleased to advise you.

## ■ Precautions to take when transporting the sweeper

If you have to transport the sweeper to another location see that it is firmly attached. Do not use a fork-lift truck to load or unload it as the sweeper could sustain damage in this way.

- Lock parking brake
- Attach sweeper only in the manner illustrated, using elasticated straps, ropes or chains

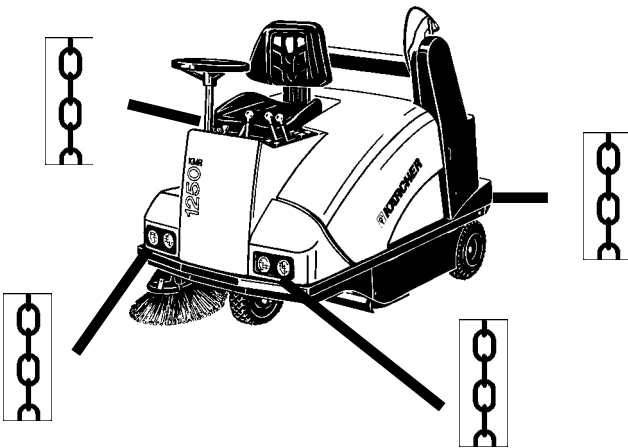

## ■ Intended usage

This sweeper

- is intended to be used for sweeping outdoor and indoor surfaces,
- corresponds to Usage Category “U” for dust that is not injurious to health,
- can only be used on public paths and highways if it has been fitted with the StVZO Accessory Kit.

## ■ Function of the main components

Drive unit

- driven by an electric motor
- continuously-adjustable hydraulic drive to rear wheels
- main brush and side brush driven by means of electric motor
- hydraulically controlled emptying of waste hopper

Sweeping mechanism

- main brush employing throw-over principle for particularly effective filling of waste hopper
- floating main brush roller with adjustable height above ground
- quick-change mechanism for main brush
- side brush can be raised and swivels automatically
- bulk waste flap for picking up larger items (e.g. cigarette packs or drink cans)

Filter system

- integrated dust extraction on the main roller by means of radial turbine
- 2 circular filters with 2 x 3 m<sup>2</sup> effective surface area
- electric filter cleaner with automatic shaking mechanism

## OPERATING CONTROLS

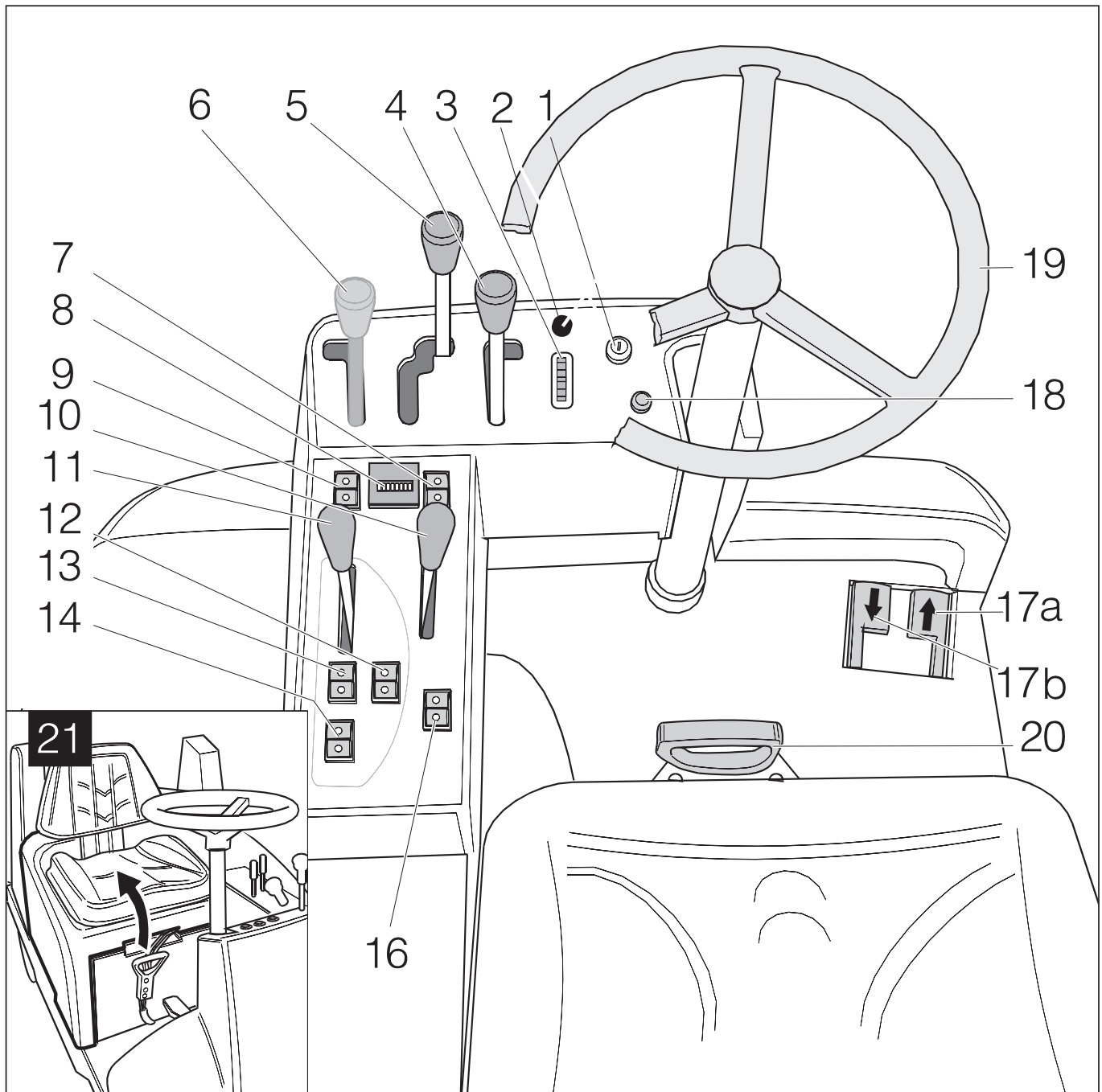

- |   |                                 |
|---|---------------------------------|
| 1. Ignition lock                        | 11. Parking brake/Driving brake |
| 2. Pilot lamp - drive malfunction       | 12. Tip waste hopper *          |
| 3. Battery charge monitoring indicator  | 13. Raise waste hopper *        |
| 4. Raise/lower RH side brush            | 14. Lower waste hopper *        |
| 5. Raise/lower main brush               | 16. Blower ON/OFF               |
| 6. Raise/lower LH side brush (optional) | 17a. Drive pedal forwards       |
| 7. Two-handed operation hydraulics      | 17b. Drive pedal backwards      |
| 8. Operating hours counter              | 18. Horn                        |
| 9. Lights                               | 19. Steering wheel              |
| 10. Bulk waste flap                     | 20. Battery plug connection     |
|   | 21. Cover open/close            |

\* Function only operative in conjunction with 7 (two-handed operation).

**■ PRIOR TO INITIAL START-UP**

**■ Directions for unloading**

 **Do not use a fork-lift truck for unloading the sweeper as the sweeper can sustain damage in this way.**

The sweeper has been fastened to a pallet for safe transport. Proceed as follows for unpacking it:

1. Remove wooden boards from the pallet and nail them to the abutments of the pallet (front end of the sweeper)
2. Remove strap attachments at the abutment points
3. Knock away the wooden blocks for locking the wheels and use them for supporting the wooden boards on right and left
4. Push the sweeper off the pallet over the ramp that has been created

- In sweepers with installed battery (1.091-111) it is possible to drive down the ramp. To do this, open motor cover and fold it back. Put gear lever into position  (slow), and close the cover again. Insert battery plug connection (at driver's seat). Key switch to "Position 1" and drive down carefully - see in addition chapter "Driving trials" and "Stopping the sweeper and switching off".
5. The side brush is tied to the frame for transportation purposes. Undo the string.

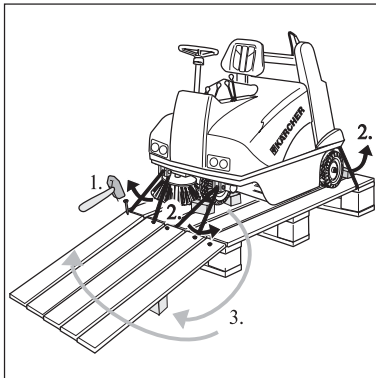

**■ Pushing the sweeper by hand**

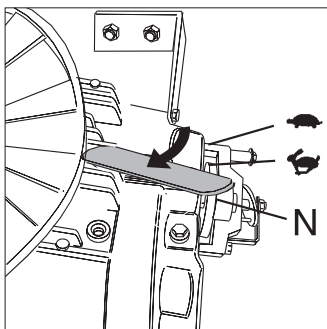

If you wish to move the sweeper without using its own drive:

- Open the engine cover.
- Fold the cover towards the rear; it will be held in place by the gas-filled spring.
- Put gear lever in direction of motion on to the symbol **N**



- Release the handbrake.
- Push the sweeper to the required destination.

**■ After sweeper has been moved by hand:**

- Apply the handbrake.
- Put gear lever into position  (fast) or  slow, as otherwise the sweeper cannot be driven.

**■ PRIOR TO EVERY START-UP**

- Check the hydraulic-fluid level, fill up if necessary (see chapter "Maintenance")
- Check main brush roller for strapping or cord that may have wrapped round it. If so, remove it.
- Examine the dust filters, if there is heavy dust accumulation shake them out
- Empty waste hopper.

**■ STARTING THE SWEEPER**

**■ Adjusting the driver's seat**

The driver's seat can be adjusted to suit persons of various heights by changing the seat position.

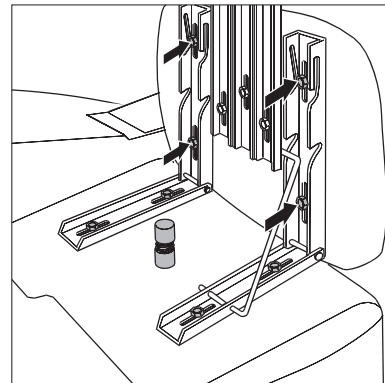

- Unhook the rods for the seat tilting device.
- Undo the 4 attachment screws
- Move the seat to the desired position.
- Tighten the screws and hook the rods back into the tilting device.

**■ Initial driving trials**

Carry out initial driving trials in an area where there is plenty of free space until you are familiar with the individual operating controls and their functions.

All indications of direction (right/left, front/rear) are given in relation to the direction of travel as seen from the driver's seat.

- Sit on the driver's seat.
- The sweeper cannot be started until the driver has sat down (seat contact switch). As soon as driver gets up from the seat, the safety shut-down comes into force and the drive control, blower fan and main brush roller drive are disconnected.





- Make sure that the LH side brush (if fitted) is still in the raised position, the RH side brush is still in the raised position, the main brush is still in the raised position.
- Put the starting key into “Position 1”. The sweeper is ready to operate.

### Important information

- The drive mechanism is equipped with an electronic overload fuse. Overload is indicated by a pilot lamp. In the event engage the parking brake and release the drive pedals (approx. 10 min.) until the drive components have cooled down.
- For safety reasons the drive mechanism remains inactive if a drive pedal is engaged before the keyswitch is turned on.

### ■ Working with the sweeper



- Lower the main brush  and, if required, the side brush as well .
- Main brush roller and side brush switch themselves on automatically.
- Switch the blower fan on in order to sweep without clouds of dust forming.
- Release the parking brake (P) by moving the lever forwards
- Slowly depress the drive pedal, the speed can be selected smoothly according to the setting.  
Depress left pedal, machine moves backwards.  
Depress right pedal, machine moves forwards.

### ■ Braking

- Release the drive pedal and the sweeper will brake automatically.

**Note:** The braking effect can be increased by careful operation of the drive pedal for the opposite direction and/or by using the parking brake.

### ■ Going up slopes

- The sweeper can be driven in the fast gear (position ) for slopes up to a gradient of 15 %.
- For slopes of gradients between 15 % and 18 %, the sweeper must be operated in low gear (position ) .

### ■ Stopping the sweeper and switching off

- Release the drive pedal. The sweeper brakes automatically and comes to a halt.
- Apply the parking brake (P).
- Make sure the main roller and side brush are raised so that the bristles are not damaged. (Main brush roller, side brush and blower fan switch off automatically).
- Turn the ignition key to “Position 0” and then remove it.
- Clean the sweeper inside and outside as required.

**Recommendation:** Clean interior with compressed air.

Wipe over the exterior with a damp cloth but do not use an aggressive cleaning agent.

- Park sweeper in a protected place and stop it from rolling away.
- Pull out battery plug connection.
- If the sweeper is shut down for a relatively long period, charge the battery at approx. two-monthly intervals, see in addition chapter “Maintenance”.

### ■ Cleaning the filter

#### Manual cleaning

While the sweeper is operating, the filter should be cleaned approx. every 15–30 minutes (depending on amount of dust).

- Switch off the blower fan. The electric filter cleaner is operated automatically for approx. 10 seconds.
- Switch on the blower fan again.

### ■ Emptying the waste hopper

#### Important information

##### Injury hazard!

No person or animal should be allowed to remain in the area traversed by the hopper while it is being emptied.

##### Danger of being crushed!

Do not reach into the shafts and linkage of the emptying mechanism.

Do not stand under the raised hopper.

##### Risk of sweeper toppling over!

If the sweeper is standing on a slope with a gradient of more than 5 %, it could topple over while the hopper is being emptied. The hopper should therefore only be emptied when the gradient at the location where the sweeper is standing is less than 5 % for the direction in which it is facing.

- Stop the sweeper.
- Raise the main brush .

**Note:** Following steps can only be performed with the sweeper set to two-handed operation.

- Raise the waste hopper, 1 + 2. 

When the hopper has reached the required height drive backwards towards the discharge container.

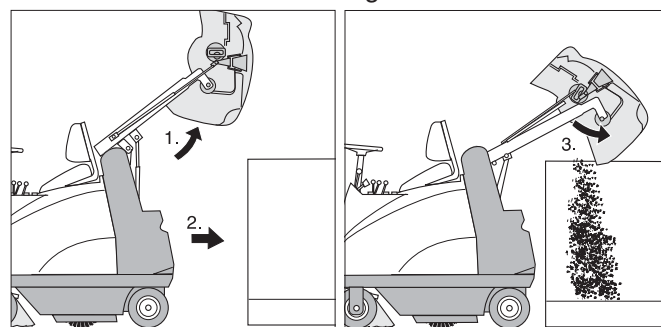

**Note:** The hopper can only be emptied when the supporting arms have reached a horizontal position. To avoid the dust billowing up when the hopper is emptied, the waste hopper should be lowered as far as possible into the discharge container.

- Tip the waste hopper

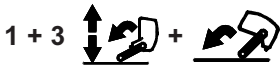

When you release the button for tipping the waste hopper, the waste hopper returns to its home position automatically.

- Raise the waste hopper, drive away from the discharge container and retract the waste hopper.



## ■ Typical applications



### Caution while sweeping!

Do not sweep up packing bands, wires or similar items, otherwise the sweeping mechanism will be damaged.

Do not sweep any burning/glowing objects.

### For cleaning even surfaces

- set the lever for the main brush roller to the middle position  (minimum brush wear).

### For cleaning uneven surfaces

- set the lever for the main brush roller to the lower position  (increased brush wear).
- switch on blower fan for dust extraction
- for cleaning right up to the edges – lower the side brush



If you are sweeping up fine dust, use the side brush as little as possible as it will increase the amount of dust stirred up by the sweeper.

If the side brush encounters an obstacle, it automatically swivels back inside the outer contours of the sweeper. Avoid collisions!

- To protect the filter from getting damp when sweeping wet surfaces, switch off the dust extraction

## ■ Picking up larger items (sticks, tins, etc.)



### Caution!

When the bulk waste flap is open, stones or grit could be thrown forwards by the main brush. Make sure therefore that when you open the flap no persons, animals or property are endangered.

- Open the bulk waste flap  by hand.
- Drive over the items to be picked up, at low speed and with the bulk waste flap open.

**Note:** In order to avoid stirring up dust unnecessarily, the bulk waste flap should be open for short periods only.

## ■ Overcoming obstacles

Obstacles up to 2 cm in height can be driven over without any problems. Before you do so, open the bulk waste flap and raise the main brush.

Obstacles more than 2 cm in height can be only be driven over with the aid of a suitable ramp.



## Battery

Safety instructions to be noted when handling batteries are:



Note instructions for use and display them where they can be easily seen at the place where the battery is charged. Work with batteries only after having had instruction from skilled personnel.



Wear protective glasses and protective clothing when working with batteries. Note the accident-prevention regulations as well as DIN VDE 0510, VDE 0105 T.1.



**No Smoking !**  
No naked flames, glowing embers or sparks in the vicinity of the battery as there is a risk of explosion and fire.



Splashes of acid in the eyes or on the skin should be rinsed out or washed away with copious amounts of clean water, thereafter consult a doctor without delay. Wash clothes contaminated with acid in water.



Risk of explosion and fire! Avoid short-circuits. Caution! Metal parts of the battery cells are always live so do not put any foreign object or tool down on the battery.



Electrolyte is highly corrosive. Under normal operating conditions there is absolutely no contact with the electrolyte. If the housing is destroyed the bound electrolyte released is equally as corrosive as the liquid form.



**Pb**



**Return to manufacturer!**  
Used batteries bearing this symbol are reusable articles and must be fed back into the recycling process. Used batteries which are not fed back into the recycling process are to be disposed of as special rubbish in compliance with the regulations.

## Checking the level of electrolyte in the battery

**Note:** Applies only to batteries that are not maintenance-free.

Check regularly the level of electrolyte in batteries filled with acid. Make sure the battery is fully charged before you carry out the check.

- If required top up each cell with distilled water up to the mark or until the lead plates are covered by approx. 1 cm of liquid.

## Charging the battery

**Note:** Use only the Kärcher recommended battery charger 6.654-107 for the battery 6.654-112 which is installed.

- Bring the sweeper to a halt, remove the starting key
- Pull out battery plug connection
- Tip seat forwards and open cover
- Connect battery cable to the charger
- Connect charger to the mains power supply and switch it on. For the period for charging see the information supplied by the manufacturer of the battery charger.

**It is essential to observe the instructions provided by the manufacturer of the battery charger!**

■ MAINTENANCE

■ Initial inspection after 8 operating hours



**Caution!**

For the safe functioning of your sweeper, an initial inspection must be carried out after 8 hours of operation. You should have the inspection done by your Kärcher Customer Service.

- inspect all bowden cables and adjust where necessary
- check that all hydraulic parts are leakproof and function correctly
- check that the handbrake functions

■ Daily maintenance

- Inspect main brush roller for strapping and/or cord, etc., which may have wrapped round it. If so remove them.
- Check dust filters. If they are heavily contaminated with dust, shake them out.
- Empty waste hopper.

■ Maintenance intervals

Keep to the maintenance schedule given in the **Maintenance booklet** (5.950-535) in order to ensure that the sweeper functions reliably and to maintain your rights under the guarantee.

The maintenance work required must be carried out by an authorised specialist workshop.

■ Maintenance tasks



**Risk of injury**

Before you work under the waste hopper in its swung-up position, you must first secure the hopper against dropping unintentionally by using the swing-out safety bar.

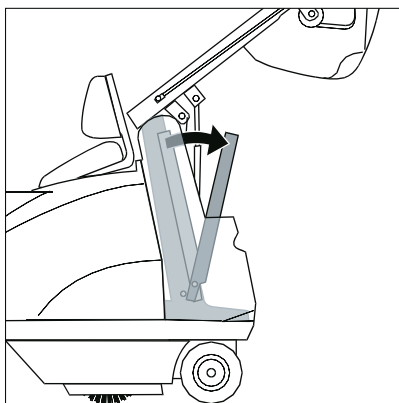

- Remove ignition key
- Pull out battery plug connection
- Open cover  
Tip seat forwards. Pull cover up by the handle grip designed for the purpose.

■ Checking the hydraulic system

- Carry out a visual inspection. If there is any loss of fluid from the hydraulic unit, cylinder or hoses, call Kärcher Customer Service.

■ Replacing the sealing skirts

The sealing skirts fulfil an important function. They retain the partial vacuum in the area round the main brush roller which is essential so that the sweeper can function properly. They ensure that sweeping can take place without clouds of dust being raised.

If the sealing skirts are damaged or worn out, they must be replaced immediately.

- Park the sweeper and switch off the engine.
- Remove the retaining screws and detach the sealing skirts.
- Fit new skirts, and align them as follows:

The side skirts should be adjusted so that they clear the ground by 1–3 mm. Adjust the rear skirt so that it clears the ground by 1-5 mm.

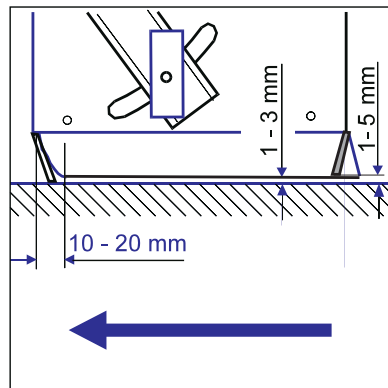

- The front skirt cannot be adjusted. Replace the skirt as soon as you see signs of excessive wear.
- Tighten the retaining screws.

■ Replacing the side brush

- Park the sweeper, switch it off and make it secure.
- Raise the side brush.
- Remove the three hex-socket bolts (SW 5).

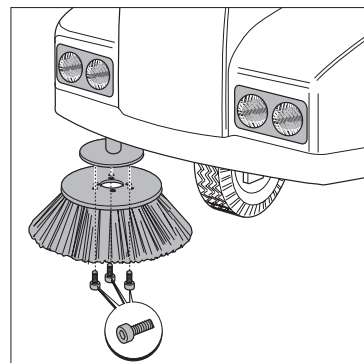

- Detach the side brush.
- Push the new side brush onto the drive pin.
- Tighten the bolts again.

## ■ Adjusting the sweeping pattern

- Open the unit cover and secure it in place.
- The sweeping pattern can be altered by turning the central adjusting knob:

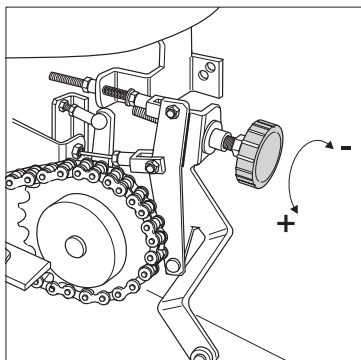

To increase size of sweeping pattern: turn adjusting knob counter-clockwise (towards -).

To reduce size of sweeping pattern: turn adjusting knob clockwise (towards +).

- After any adjustments have been made, check the sweeping pattern.

Drive the sweeper onto a dusty surface and apply the parking brake.

Lower the main brush (lever set to middle position) and allow it to brush the floor for several seconds.

Raise the main brush and drive backwards a short distance with the bulk waste flap open (first release the parking brake).

The width of the sweeping pattern should be 30–50 mm.

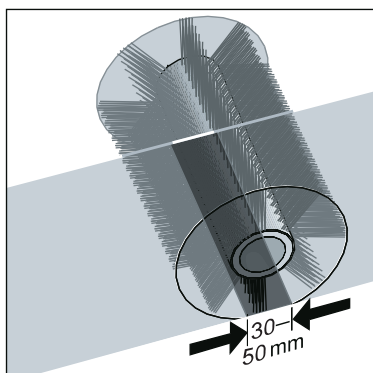

**Note:** The shape of the sweeping pattern should not be trapezoidal. If it is, call Kärcher Customer Service.

## ■ Replacing the main brush roller

- Park the sweeper and switch off the engine.
- Lower the brush roller.
- Open the RH side flap **1** (seen in direction of travel).
- Undo the retaining bolt on the lower forked head **2** and swivel the push rod towards the rear.
- Unscrew the knurled knob **3**.
- Remove the oscillating linkage **4**.

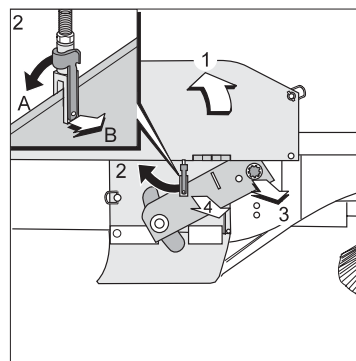

- Open the flap over the end of the brush roller **5** (turn-lock fastener).
- Pull out the brush roller **6**.

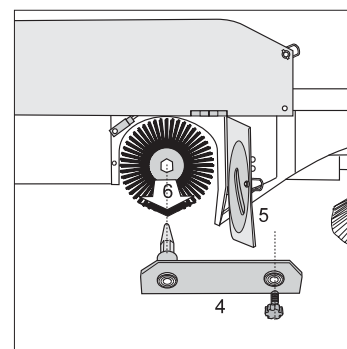

- Screw in the knob for adjusting the sweeping pattern as far as it will go (clockwise, towards -).
- Fit the new brush roller in reverse order to the removal procedure.

**Note:** Make sure the bristles point in the right direction – see illustration.

Brush roller seen from above

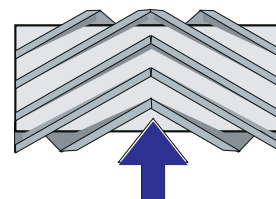

Direction of travel

- Set up the sweeping pattern by turning the adjusting knob – see “Adjusting the sweeping pattern”.

■ Replacing fuses

- Park the sweeper, switch it off and make it secure.
- Pull out battery plug connection and open the unit cover.
- Replace blown fuses with ones with the same rating.

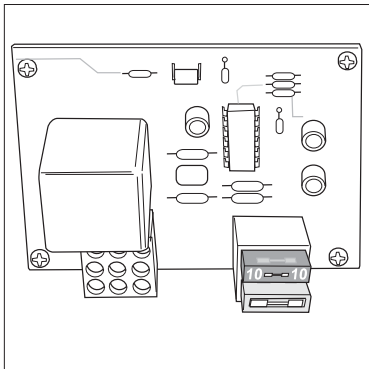

**Note:** If a fuse blows repeatedly, this indicates a fault somewhere in the electrical system. Please call Kärcher Customer Service.

■ Replacing the dust filters

The dust filters should be inspected for damage every 50 operating hours.

A significant build-up of dust at the air outlet from the fan is a sign of a filter that is not fitted properly or is defective.

- Raise the hopper half way **1**.
- Release the catches on the filter box **2**.
- Swivel the filter box forwards and lift it off **3**.

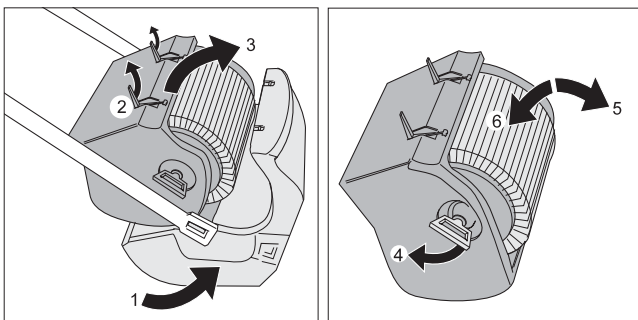

- Open out the handle, pull it outwards and turn it through 90° (make sure it engages) **4**.
- Remove the filter cartridge **5**.
- Insert a new filter cartridge (pins should fit into the holes) **6**.
- Turn the handle back to its original position and make sure it locks in place.
- Mount the filter box and engage the catches.

■ Replace light unit

- Stop the machine and turn it off
- Take out the ignition key
- Undo 6 screws **S** on the panel

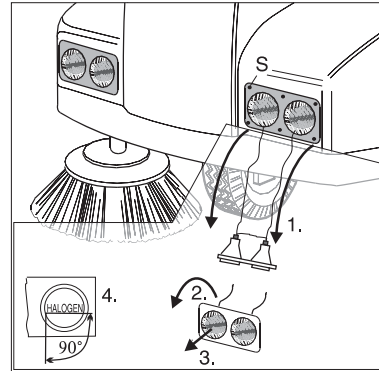

- Remove the panel **1**
- Unscrew the Phillips screw between the supports of the lamp holder on the defective headlight
- Turn the lens of the defective headlight anti-clockwise about 1/4 of a turn **2** and take out reflector housing **3**
- Replace light unit
- Insert reflector housing with new light unit in panel again from below and secure with about 1/4 of a turn clockwise. Make certain it engages properly, the label HALOGEN on the headlight glass must be able to be read horizontally **4**
- Screw in again the screw between the supports, then secure the panel with the 6 screws.

## ■ Technical Data

### Dimensions and weights:

|                                   |       |    |
|-----------------------------------|-------|----|
| Length                            | 1.650 | mm |
| Width                             | 1.000 | mm |
| Height                            | 1.270 | mm |
| Weight unladen (ready to operate) | 580   | kg |
| Total permissible weight          | 730   | kg |

### Driving and sweeping performance:

|   |       |    |
|---|-------|----|
| Sweeping path width without side brush  | 750   | mm |
| Sweeping path width with 1 side brush   | 1.000 | mm |
| Sweeping path width with 2 side brushes | 1.300 | mm |

### Fast gear (Position )

|                        |    |      |
|------------------------|----|------|
| Max. speed             | 6  | km/h |
| Max. gradient of climb | 15 | %    |

### Low gear (Position )

|                        |    |      |
|------------------------|----|------|
| Max. speed             | 4  | km/h |
| Max. gradient of climb | 18 | %    |

### Surface area performance (theoretical):

|                     |       |                   |
|---------------------|-------|-------------------|
| Without side brush  | 4.500 | m <sup>2</sup> /h |
| With 1 side brush   | 6.000 | m <sup>2</sup> /h |
| With 2 side brushes | 7.800 | m <sup>2</sup> /h |

### Waste hopper:

|                     |       |                |
|---------------------|-------|----------------|
| Theoretical volume  | 100   | l              |
| Max. usable volume  | 80    | l              |
| Lift of stroke      | 1.430 | mm             |
| Filter surface area | 6     | m <sup>2</sup> |

### Sweeping mechanism:

|   |     |    |
|---|-----|----|
| Main brush roller with rows of bristle in V-formation |     |    |
| Diameter of main brush roller                         | 285 | mm |
| Diameter of side brush                                | 450 | mm |

### Tyres

|             |        |    |
|-------------|--------|----|
| Diameter    | 300    | mm |
| Designation | 4.00-4 |    |

### Lighting

|            |              |
|------------|--------------|
| Light unit | DIN 49 848   |
|            | HS3 6V/2,4 W |

### Battery:

e.g. HAGEN Favorit 24 V/240 Ah  
 Your Kärcher Customer Service will be pleased to advise you about the existing supply.

### Motor data:

|                                  |             |
|----------------------------------|-------------|
| Drive control motor, AMER MP80 M | 24 V/1100 W |
| Main brush motor, AMER MP80/2    | 24 V/600 W  |
| Blower motor, AMER MP80/2        | 24 V/600 W  |

### Drive system:

Mechanical gear drive with differential, operating on the rear wheels.

### Hydraulic fluid:

|            |                   |
|------------|-------------------|
| Class      | DIN HVLP 51 524/2 |
|            | 46 c St /40 °C    |
| Capacity * | 1.5 l             |

\* We recommend BP BARTRAN Hydraulic Fluid.

**Protection type:** dripping-water protection IPX3

### Ambient conditions:

|                                  |           |    |
|----------------------------------|-----------|----|
| – temperature                    | –5 to +40 | °C |
| – air humidity, not wet with dew | 0–90      | %  |

### Operating period:

With one battery charging and under favourable conditions the operating period is 3 hours. It is dependent on several factors:

- nature of the ground and evenness of the terrain
- maintenance of the unit
- type and wear of the brush roller.

### Noise emission

|                                     |    |       |
|-------------------------------------|----|-------|
| Sound level (EN 60704-1)            | 74 | dB(A) |
| Guaranteed noise level (2000/14/EC) | 94 | dB(A) |

### Machine vibration

|                                  |       |                  |
|----------------------------------|-------|------------------|
| Rated vibration value (ISO 5349) |       |                  |
| Upper limb measurements          | < 2,5 | m/s <sup>2</sup> |
| Feet/seating area                | < 0,5 | m/s <sup>2</sup> |

## ■ Troubleshooting

| <b>Problem</b>   | <b>Possible cause</b>   | <b>Remedy</b>  |
|--|---|--|
| <b>Sweeper does not move</b>                               | Battery is flat   | Recharge or replace battery                                      |
|  | Warning light flashes   | Follow the startup sequence<br>Call Customer Service             |
|  | Fuse has blown  | Replace fuse   |
|  | Free-wheeling mechanism switched on                                       | See "Pushing the sweeper by hand"                                |
|  | The safety cutout triggered   | Reset the safety cutout  |
| <b>Brushes do not rotate</b>                               | V-belt has snapped  | Call Customer Service  |
|  | V-belt too loose  | Check belt tension and adjust as required                        |
|  | Main brush or side brush has been jammed by packing bands or similar item | Remove blockage  |
|  | Fuse has blown  | Replace fuse   |
| <b>Blower fan does not rotate</b>                          | Fan limit switch is not being operated                                    | Lower waste hopper completely so that limit switch is operated   |
|  | Fuse has blown  | Replace fuse   |
| <b>Poor sweeping results</b>                               | Brushes are worn down   | Replace brushes  |
|  | Waste hopper is full  | Empty waste hopper   |
|  | Incorrect sweeping pattern  | Adjust sweeping pattern  |
|  | Filter is blocked   | Clean or replace filter  |
| <b>Dust is stirred up during sweeping</b>                  | Worn out seals on sweeper, filter not fitted properly or defective        | Replace defective seals; fit filter correctly or replace it      |
| <b>Lifting mechanism for emptying hopper does not work</b> | Fuse has blown  | Replace fuse or inform Customer Service if fuse blows repeatedly |
|  | Defective switch  | Inform Customer Service  |
|  | Defective hydraulic unit  | Inform Customer Service  |



# KMR 1250 BAT

1.091-101.0

# KMR 1250 BAT Package

1.091-111.0

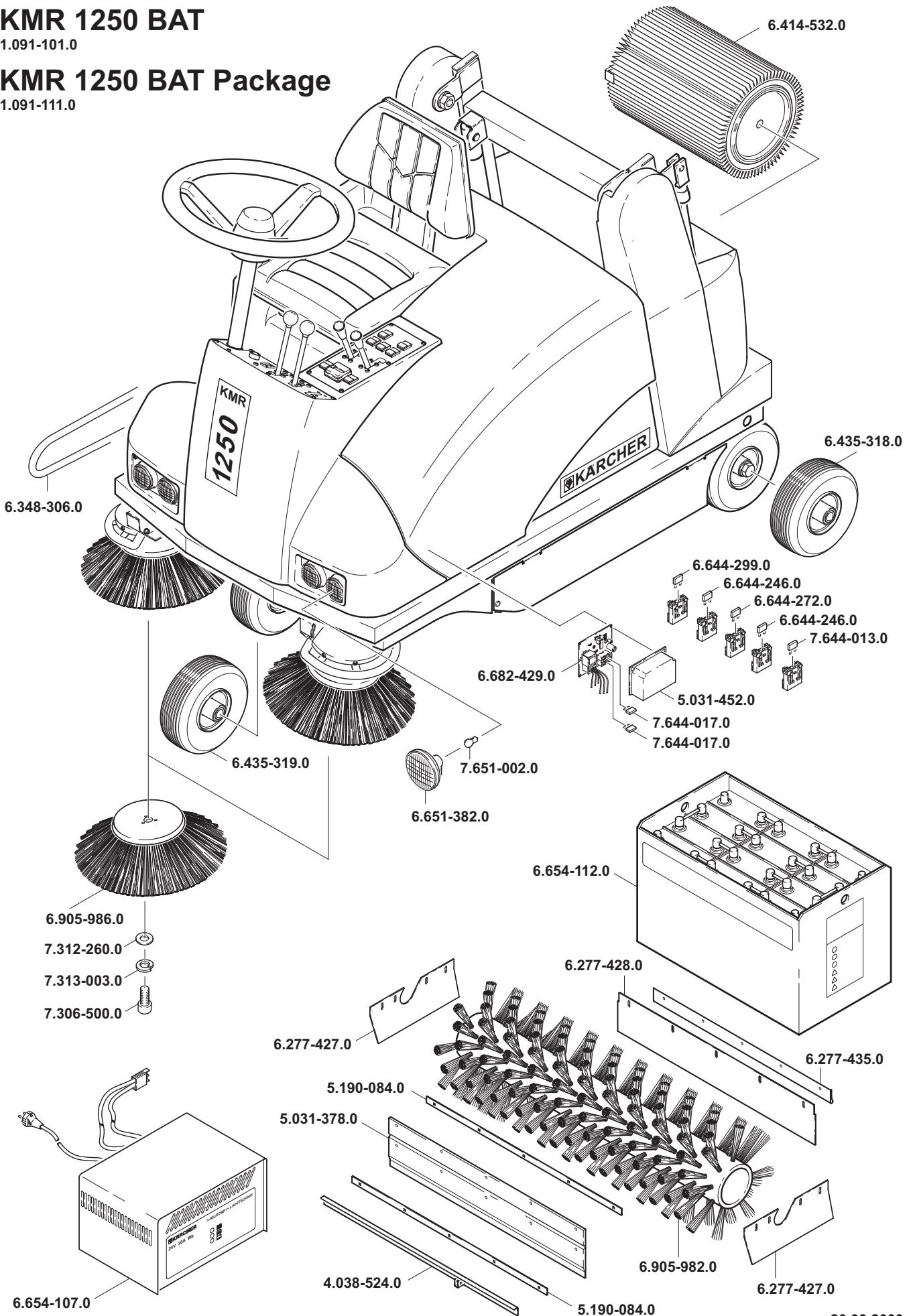

20.03.2000

## **D** EG-Konformitätserklärung

Hiermit erklären wir, daß die nachfolgend bezeichnete Maschine aufgrund ihrer Konzipierung und Bauart sowie in der von uns in Verkehr gebrachten Ausführung den einschlägigen grundlegenden Sicherheits- und Gesundheitsanforderungen der EG-Richtlinien entspricht.

Bei einer nicht mit uns abgestimmten Änderung der Maschine verliert diese Erklärung ihre Gültigkeit.

|          |                                      |
|----------|--------------------------------------|
| Produkt: | <b>Kehrsaugmaschine Aufsitzgerät</b> |
| Typ:     | <b>1.091-xxx</b>                     |

Einschlägige EG-Richtlinien:

**EG-Maschinenrichtlinie (98/37/EG)**

**EG-Richtlinie Elektromagnetische Verträglichkeit (89/336/EWG), geändert durch 91/263/EWG, 92/31/EWG, 93/68/EWG**

**EG-Richtlinie über Geräuschemissionen (2000/14/EU)**

Angewandte harmonisierte Normen:

**DIN EN 60 335 - 1**

**DIN EN 60 335 - 2 - 72**

**DIN EN 55 014 - 1 : 2000 + A1: 2001**

**DIN EN 55 014 - 2 : 1997**

Angewandte nationale Normen: –

Angewandtes Konformitätsbewertungsverfahren: **Anhang V**

Gemessener Schallleistungspegel: 92 dB(A)

Garantierter Schallleistungspegel: 94 dB(A)

Es ist durch interne Maßnahmen sichergestellt, daß die Seriengeräte immer den Anforderungen der aktuellen EG-Richtlinien und den angewandten Normen entsprechen.

Die Unterzeichnenden handeln im Auftrag und mit Vollmacht der Geschäftsführung.

## **GB** EU Declaration of Conformity

We hereby declare that the equipment described below conforms to the relevant fundamental safety and health requirements of the appropriate EU Directives, both in its basic design and construction as well as in the version marketed by us.

This declaration will cease to be valid if any modifications are made to the machine without our express approval.

|          |                                 |
|----------|---------------------------------|
| Product: | <b>Sweeping suction machine</b> |
| Model:   | <b>1.091-xxx</b>                |

Relevant EU Directives:

**EU Machinery Directive (98/37/EEC)**

**EU Directive on Electromagnetic Compatibility (89/336/EEC), amended by 91/263/EEC, 92/31/EEC, 93/68/EEC**

**EC directive on noise emissions (2000/14/EU)**

Harmonised standards applied:

**DIN EN 60 335 - 1**

**DIN EN 60 335 - 2 - 72**

**DIN EN 55 014 - 1 : 2000 + A1: 2001**

**DIN EN 55 014 - 2 : 1997**

National standards applied: –

Applied conformity evaluation procedure: **Appendix V**

Measured sound power level: 92 dB(A)

Guaranteed sound power level: 94 dB(A)

Appropriate internal measures have been taken to ensure that series-production units conform at all times to the requirements of current EU Directives and relevant standards.

The signatories are empowered to represent and act on behalf of the company management.

## **NL** EU-conformiteitsverklaring

Hiermee verklaren wij dat de hierna vermelde machine op grond van haar concipiëring en constructie en in de door ons in omloop gebrachte uitvoering beantwoordt aan de desbetreffende veiligheids- en gezondheidsvoorschriften van de EG-richtlijnen.

Na een wijziging aan de machine die niet in overleg met ons wordt uitgevoerd, verliest deze verklaring haar geldigheid.

|          |                        |
|----------|------------------------|
| Produkt: | <b>Veegzuigmachine</b> |
| Type:    | <b>1.091-xxx</b>       |

Desbetreffende EG-richtlijn:

**EG-machinerichtlijn (98/37/EEG)**

**EG-richtlijn elektromagnetische verenigbaarheid (89/336/EEG), gewijzigd door 91/263/EEG, 92/31/EEG en 93/68/EEG**

**EG-richtlijn geluidsemissies (2000/14/EU)**

Toegepaste geharmoniseerde normen:

**DIN EN 60 335 - 1**

**DIN EN 60 335 - 2 - 72**

**DIN EN 55 014 - 1 : 2000 + A1: 2001**

**DIN EN 55 014 - 2 : 1997**

Toegepaste nationale normen: –

Toegepaste conformiteitswaarderingmethode: **aanhangsel V**

Gemeten geluidsvermogeniveau: 92 dB(A)

Gegarandeerd geluidsvermogeniveau: 94 dB(A)

Door interne maatregelen is er voor gezorgd dat de standaard-apparaten altijd beantwoorden aan de eisen van de actuele richtlijnen en de toegepaste normen.

De ondergetekenden handelen in opdracht en op volmacht van de bedrijfsleiding.

## **E** Declaración de conformidad de la Unión Europea

Por la presente declaramos los abajo firmantes que la máquina designada a continuación cumple, tanto por su concepción y clase de construcción como por la ejecución que hemos puesto en circulación, las normas fundamentales de seguridad y protección de la salud formuladas en las directivas comunitarias correspondientes.

La presente declaración pierde su validez en caso de alteraciones en la máquina efectuadas sin nuestro consentimiento explícito.

|           |                             |
|-----------|-----------------------------|
| Producto: | <b>Barredora-aspiradora</b> |
| Modelo:   | <b>1.091-xxx</b>            |

Directivas comunitarias aplicables:

**Directiva comunitaria sobre máquinas (CEE 98/37)**

**Directiva sobre compatibilidad electromagnética (CEE 89/336), modificada mediante CEE 91/263, CEE 92/31 y CEE 93/68**

**Directiva comunitaria sobre emisiones sonoras (UE 2000/14)**

Normas armonizadas aplicadas:

**DIN EN 60 335 - 1**

**DIN EN 60 335 - 2 - 72**

**DIN EN 55 014 - 1 : 2000 + A1: 2001**

**DIN EN 55 014 - 2 : 1997**

Normas nacionales aplicadas: –

Procedimiento de evaluación de la conformidad aplicado: **Anexo V**

Nivel de potencia acústica medido: 92 dB(A)

Nivel de potencia acústica garantizado: 94 dB(A)

Mediante una serie de medidas internas, queda asegurado que los aparatos y equipos de serie cumplan siempre las exigencias formuladas en las directivas comunitarias actuales y en las normas correspondientes a aplicar.

Los firmantes actúan autorizados y con poder otorgado por la dirección de la empresa.

## **F** Déclaration de conformité européenne

Par la présente, nous déclarons que la machine ci-après répond, de par sa conception et sa construction ainsi que de par le modèle que nous avons mis sur le marché, aux exigences de sécurité et d'hygiène en vigueur de la directive européenne.

En cas de modification de la machine effectuée sans notre accord, cette déclaration sera caduque.

|          |                                       |
|----------|---------------------------------------|
| Produit: | <b>Machine de balayage-aspiration</b> |
| Type:    | <b>1.091-xxx</b>                      |

Directives européennes en vigueur:

**Directive européenne sur les machines (98/37/CE)**

**Directive européenne sur la compatibilité électromagnétique (89/336/CE), modifiée par 91/263/CE, 92/31/CE, 93/68/CE**

**Directive européenne sur les émissions sonores (2000/14/CE)**

Normes harmonisées appliquées:

**DIN EN 60 335 - 1**

**DIN EN 60 335 - 2 - 72**

**DIN EN 55 014 - 1 : 2000 + A1: 2001**

**DIN EN 55 014 - 2 : 1997**

Normes nationales appliquées: –

Procédure appliquée d'évaluation de la conformité: **annexe V**

Niveau de puissance sonore mesuré: 92 dB(A)

Niveau de puissance sonore garanti: 94 dB(A)

La conformité permanente des appareils de série avec les exigences consignées dans les directives actuelles de la CE et avec les normes appliquées est garantie par des mesures internes.

Les soussignés agissent par ordre et avec les pleins pouvoirs de la Direction commerciale.

## **I** Dichiarazione di conformità CE

Dichiariamo con la presente, che la macchina qui di seguito indicata, in base alla sua concezione e al tipo di costruzione, e nella versione da noi introdotta sul mercato, è conforme ai relativi requisiti fondamentali di sicurezza e di sanità delle direttive della CE.

In caso di modifica apportate alla macchina senza il nostro accordo, questa dichiarazione perde la sua validità.

|           |                                |
|-----------|--------------------------------|
| Prodotto: | <b>Spazzatrice aspiratrice</b> |
| Tipo:     | <b>1.091-xxx</b>               |

Directive CE pertinenti:

**Direttiva macchina CE (98/37/CEE)**

**Direttiva compatibilità elettromagnetica CE (89/336/CEE), modificata dalle 91/263/CEE, 92/31/CEE, 93/68/CEE**

**Direttiva CEE sulle emissioni acustiche (2000/14/UE)**

Norme armonizzate applicate:

**DIN EN 60 335 - 1**

**DIN EN 60 335 - 2 - 72**

**DIN EN 55 014 - 1 : 2000 + A1: 2001**

**DIN EN 55 014 - 2 : 1997**

Norme nazionali applicate: –

Procedura di valutazione di conformità applicata: **Allegato V**

Livello di potenza sonora misurato: 92 dB(A)

Livello di potenza sonora garantito: 94 dB(A)

Mediante accorgimenti interni, è stato assicurato che gli apparecchi di serie siano sempre conformi ai requisiti delle attuali direttive CE e alle norme applicate.

I firmatari agiscono su incarico e con i poteri dell'Amministrazione.

## **P** CE - Declaração de conformidade

Nós declaramos pelo presente instrumento que a máquina abaixo indicada corresponde, na sua concepção, fabricação bem como no tipo por nós comercializado, às exigências básicas de segurança e de saúde da diretiva da CE.

Se houver uma modificação na máquina sem o nosso consentimento prévio, a presente declaração perderá a sua validade.

|          |                          |
|----------|--------------------------|
| Produto: | <b>Vassoura mecânica</b> |
| Tipo:    | <b>1.091-xxx</b>         |

Directivas aplicáveis da CE:

**Directiva de máquinas CE (98/37/CEE)**

**Directiva de compatibilidade electromagnética CE (89/336/CEE), modificada 91/263/CEE, 92/31/CEE, 93/68/CEE**

**Directiva CE sobre emissões de ruído (2000/14/UE)**

Normas harmonizadas aplicadas:

**DIN EN 60 335 - 1**

**DIN EN 60 335 - 2 - 72**

**DIN EN 55 014 - 1 : 2000 + A1: 2001**

**DIN EN 55 014 - 2 : 1997**

Normas nacionais aplicadas: –

Processo de avaliação de conformidade aplicado: **Suplemento V**

Nível de potência acústica medido: 92 dB(A)

Nível de potência acústica garantido: 94 dB(A)

Assigura-se, através de medidas internas da empresa, que os aparelhos de série correspondem sempre às exigências das directivas actualizadas da CE e às normas aplicadas.

Os abaixo assinados, actuam e representam através de procuração a gerência.

## **GR** Δήλωση Πιστότητας ΕΚ

Εμείς, δηλώνουμε με την παρούσα, ότι το μηχάνημα που χαρακτηρίζεται παρακάτω, λόγω του σχεδιασμού και του τρόπου κατασκευής, όπως και λόγω της παραλλαγής που διατίθεται από μας στην αγορά, ανταποκρίνεται στις σχετικές βασικές απαιτήσεις ασφαλείας και υγιεινής των Οδηγιών ΕΚ.

Σε περίπτωση αλλαγών στο μηχάνημα χωρίς προηγούμενη συννενοήση μαζί μας, παύει να ισχύει η παρούσα δήλωση.

|         |                                       |
|---------|---------------------------------------|
| Προϊόν: | <b>Μηχανικό σάρωθρο με αναρρόφηση</b> |
| Τύπος:  | <b>1.091-xxx</b>                      |

Σχετικές Οδηγίες ΕΚ:

**Οδηγία ΕΚ σχετικά με τις μηχανές (98/37/ΕΟΚ)**

**Οδηγία ΕΚ περί ηλεκτρομαγνητικής συμβατότητας (89/336/ΕΟΚ), που τροποποιήθηκε με την Οδηγία 91/263/ΕΟΚ, 92/31/ΕΟΚ, 93/68/ΕΟΚ**

**Οδηγία ΕΚ περί εκπομπών θορύβων (2000/14/ΕΕ)**

Εναρμονισμένα πρότυπα που έχουν εφαρμοσθεί:

**DIN EN 60 335 - 1**

**DIN EN 60 335 - 2 - 72**

**DIN EN 55 014 - 1 : 2000 + A1: 2001**

**DIN EN 55 014 - 2 : 1997**

Εθνικά πρότυπα που έχουν εφαρμοσθεί: –

Εφαρμοσμένη διαδικασία αξιολόγησης πιστότητας: **Παράρτημα V**

Μετρημένη στάθμη ακουστικής ισχύος: 92 dB(A)

Εγγυημένη στάθμη ακουστικής ισχύος: 94 dB(A)

Με ληφθέντα εσωτερικά μέτρα έχει εξασφαλισθεί, ότι οι συσκευές σειράς κατασκευής ανταποκρίνονται πάντα στις απαιτήσεις των επικαίρων οδηγιών ΕΚ και στα εφαρμοσθέντα πρότυπα.

Οι υπογράφωντες ενεργούν με εντολή και κατόπιν εξουσιοδότησης της Γενικής Διεύθυνσης.

## DK EU-overensstemmelseserklæring

Herved erklærer vi at nedenstående maskine på grund af sin udførelse og konstruktion i den udførelse, i hvilken den sælges af os, overholder EU-direktivernes relevante, grundlæggende sikkerheds- og sundhedsmæssige krav.

Hvis maskinen ændres uden aftale med os, mister denne attest sin gyldighed.

|          |                 |
|----------|-----------------|
| Produkt: | Fejesugemaskine |
| Type:    | 1.091-xxx       |

Relevante EU-direktiver:

EU-maskindirektiv (98/37/EØF)

EU-direktiv om elektromagnetisk kompatibilitet (EMC)(89/336/EØF)

som ændret ved 91/263/EØF, 92/31/EØF og 93/68/EØF

EF-direktiv for støjemissioner (2000/14/EU)

Harmoniserede standarder, der blev anvendt:

DIN EN 60 335 - 1

DIN EN 60 335 - 2 - 72

DIN EN 55 014 - 1 : 2000 + A1: 2001

DIN EN 55 014 - 2 : 1997

Nationale standarder, der blev anvendt: –

Anvendte procedurer for overensstemmelsesvurdering: **Bilag V**

Målt lydeffektniveau: 92 dB(A)

Garanteret lydeffektniveau: 94 dB(A)

Interne forholdsregler sikrer, at serieapparaterne altid opfylder kravene fra de aktuelle EU-direktiver og de standarder, der blev anvendt.

Underskrivne handler på forretningsledelsens vegne og med dennes fuldmagt.

## NL EU-KONFORMITETSERKLÆRING

Vi erklærer herved at maskinen som er beskrevet nedenfor, i konstruktion og udførelse tilsvarende markedsførte modell og er i overensstemmelse med de gjeldende og grundlæggende sikkerheds- og helsekrav i EU-direktivet.

Denne erklæring mister sin gyldighed dersom maskinen ændres uden efter aftale med oss.

|          |                          |
|----------|--------------------------|
| Produkt: | Selvoptagende feiemaskin |
| Type:    | 1.091-xxx                |

Gjældende EU-direktiv:

EU-direktiv for maskiner (98/37/EØF)

EU-direktiv for elektromagnetisk toleranse (89/336/EØF), endret ved 91/263/EØF, 92/31/EØF og 93/68/EØF

EU-direktiv vedr. støytuflipp (2000/14/EU)

Anvendte overensstemmende normer:

DIN EN 60 335 - 1

DIN EN 60 335 - 2 - 72

DIN EN 55 014 - 1 : 2000 + A1: 2001

DIN EN 55 014 - 2 : 1997

Anvendte nasjonale normer: –

Anvendte samsvars vurderinger: **Vedlegg V**

Målt støynivå: 92 dB(A)

Garanteret støynivå: 94 dB(A)

Gjennom interne tiltak er det sikret at serieproduserte maskiner alltid er i overensstemmelse med kravene i de aktuelle EU-direktiver og anvendte normer.

Undertegnede handler etter oppdrag og med fullmakt fra ledelsen.

## PL

Deklaracja zgodności z normami Wspólnoty Europejskiej Niniejszym oświadczamy, że poniżej wymieniona maszyna ze względu na jej koncepcję i budowę, jak i wprowadzone przez nas w obieg wykonanie, odpowiada odpowiednim i podstawowym wymogom bezpieczeństwa i zdrowia i poniżej wymienionym wytycznym Wspólnoty Europejskiej.

Jeżeli przeprowadzone w maszynie zmiany nie zostaną z nami uzgodnione, oświadczenie to traci na ważności.

|  |
|--|
| Wyrób: zamiatarka mechaniczna / maszyna z siedzeniem |
| Typ: 1.091-xxx                                       |

Odnosne wytyczne Wspólnoty Europejskiej

Wytyczna Wspólnoty Europejskiej dotycząca maszyn (98/37/EG)

Wytyczna Wspólnoty Europejskiej dotycząca zgodności elektromagnetycznej (89/336/EG) zmieniona przez 91/263/EG, 92/31/EG, 93/68/EG

Wytyczna Wspólnoty Europejskiej e misja hałasu (2000/14/EU)

Zastosowane tzw. normy zharmonizowane, tzn. dostosowane do norm Wspólnoty Europejskiej

DIN EN 60335-1

DIN EN 60335-2-79

DIN EN 55014-2:1997

Zastosowane normy krajowe: –

Zastosowana metoda oceny zgodności: **Załącznik V**

Mierzony poziom mocy akustycznej: 92 dB(A)

Gwarantowany poziom mocy akustycznej: 94 dB(A)

Wewnętrzne zarządzenia w przedsiębiorstwie gwarantują dostosowanie urządzeń seryjnych do aktualnych wytycznych Wspólnoty Gospodarczej i stosowanych norm. Sygnatariusze działają w imieniu i z pełnomocnictwa dyrekcji przedsiębiorstwa.

## S Förssäkrän om överensstämmelse

Härmed försäkras vi att den enligt nedan angivna maskinen till konstruktion, byggnadsätt och i av oss levererat utförande motsvarar tillämpliga baskrav beträffande säkerhet och hälsa enligt EU-direktiven.

Vid ändringar på maskinen som icke avtalats med oss upphör denna försäkrän att gälla.

|          |           |
|----------|-----------|
| Produkt: | Sopmaskin |
| Typ:     | 1.091-xxx |

Tillämpliga EU-direktiv:

EG maskindirektiv (98/37/EEG)

EG direktiv för elöverkänslighet (89/336/EEG), ändrat genom 91/263/EEG, 92/31/EEG, 93/68/EEG

EG-direktiv för buller (2000/14/EU)

Tillämpade harmoniserade normer:

DIN EN 60 335 - 1

DIN EN 60 335 - 2 - 72

DIN EN 55 014 - 1 : 2000 + A1: 2001

DIN EN 55 014 - 2 : 1997

Tillämpade nationella normer: –

Tillämpat värderingsförfarande för överensstämmelse: **Bilaga V**

Uppmätt ljudeffektnivå: 92 dB(A)

Garanterad ljudeffektnivå: 94 dB(A)

Vi har genom interna åtgärder säkerställt, att serietillverkade maskiner alltid motsvarar aktuella EU-direktiv och tillämpade normer.

De undertecknade agerar på uppdrag av och med fullmakt av företagsledningen.

## FIN EU-vaatimusten mukaisuusvakuutus

Me vakuutamme, että alla mainittu tuote vastaa suunnittelultaan ja rakenteeltaan sekä valmistustavaltaan EU-direktiivien asianomaisia turvallisuus- ja terveysvaatimuksia.

Jos koneeseen tehdään muutoksia, joista ei ole sovittu kanssamme, tämä vakuutus ei ole enää voimassa.

|         |              |
|---------|--------------|
| Tuote:  | Lakaisuimuri |
| Tyyppi: | 1.091-xxx    |

Asianomaiset EU-direktiivit:

EU-konedirektiivi (98/37/ETY)

EU-direktiivi sähkömagneettinen yhteensopivuus (89/336/ETY) muutettu 91/263/ETY, 92/31/ETY, 93/68/ETY

EY-direktiivi melupäästöistä (2000/14/EU)

Sovelletut harmonisoidut normit:

DIN EN 60 335 - 1

DIN EN 60 335 - 2 - 72

DIN EN 55 014 - 1 : 2000 + A1: 2001

DIN EN 55 014 - 2 : 1997

Sovelletut kansalliset normit: –

Sovellettu vaatimusten mukaisuusmenettely: **liite V**

Mitattu äänitehotaso: 92 dB(A)

Taattu äänitehotaso: 94 dB(A)

Sisäisin toimenpitein varmistetaan, että sarjatuotantolaitteet vastaavat aina voimassaolevien EU-direktiivien vaatimuksia ja sovellettuja normeja.

Allekirjoittaneet toimivat yrityksen johdon toimeksiannosta ja valtuuttamina.

 KÄRCHER



5.957-544  
(04/03)

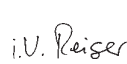

S. Reiser



H. Jenner

Alfred Kärcher Kommanditgesellschaft. Sitz Winnenden.  
Registergericht: Waiblingen, HRA 169.  
Persönlich haftende Gesellschafterin: Kärcher Reinigungstechnik GmbH.  
Sitz Winnenden, 2404 Registergericht Waiblingen, HRB  
Geschäftsführer: Dr. Bernhard Graf, Hartmut Jenner,  
Georg Metz

Alfred Kärcher GmbH & Co. KG  
Cleaning Systems  
Alfred-Kärcher-Str. 28–40  
P.O. Box 160  
D-71349 Winnenden  
Tel.: ++ 49 71 95 14-0  
Fax: ++ 49 71 95 22 12

## Free Manuals Download Website

<http://myh66.com>

<http://usermanuals.us>

<http://www.somanuals.com>

<http://www.4manuals.cc>

<http://www.manual-lib.com>

<http://www.404manual.com>

<http://www.luxmanual.com>

<http://aubethermostatmanual.com>

Golf course search by state

<http://golfingnear.com>

Email search by domain

<http://emailbydomain.com>

Auto manuals search

<http://auto.somanuals.com>

TV manuals search

<http://tv.somanuals.com>