 Please read and comply with these original instructions prior to the initial operation of your appliance and store them for later use or subsequent owners.

Contents

Safety instructions	EN - 1
Function	EN - 2
Environmental protection	EN - 2
Proper use	EN - 2
Device elements	EN - 3
Operation	EN - 5
Frost protection	EN - 8
Maintenance and care	EN - 10
Faults	EN - 14
Technical specifications	EN - 16
Accessories and Spare Parts	EN - 17
Warranty	EN - 17
CE declaration	EN - 17

Safety instructions

Hazard levels

Danger

Immediate danger that can cause severe injury or even death.

Warning

Possible hazardous situation that could lead to severe injury or even death.

Caution

Possible hazardous situation that could lead to mild injury to persons or damage to property.

Safety instructions

Danger

- This appliance must only be operated, maintained and repaired by authorised, skilled and trained personnel.
- Only physically and mentally fit and reliable people should operate and care for this high pressure water jets (minimum age 18). The operator or his representative must be certain that the operator is familiar with the appliance and its application and that he will be able to perform the assigned tasks responsibly.
- Fatigue, health issues, influence by alcohol or medications lead to a higher safety risk while operating the machine.
- For safety reasons, a second person must always be present when the appliance is being operated, in order to be able to shut off the appliance in emergencies and to summon help if needed.
- The local and relevant accident prevention directives as well as other, generally applicable safety, health and work related regulations are to be observed.
- The user is obliged to only operate the appliance while it is in flawless condition.

- Safety features on the appliance and the spray unit must never be removed, modified to made inoperable.
- Only use hose lines, spray units and accessories approved for the maximum working pressure of the appliance.
- Hoses, pipes and connected accessories must be in good condition and installed properly.
- The application should not be operated in explosive environments.
- If the appliance is used in hazardous areas (e.g. filling stations) the corresponding safety provisions must be observed.
- During jet spray work, nobody besides the operator is allowed in a radius of 10 m around the spray unit.
- Never direct the water jet on to persons, animals, the appliance itself or electrical components.
- Modifications of the set operating over pressure on the appliance may only be performed if previously agreed with the operator of the spray unit.
- Risk of injury! The recoil pressure of the spray pipe can throw you off-balance. You may fall. The spray jet can fly off and cause damage to persons. Search a secure place to stand and hold the gun firmly. Never hold on tightly to the lever of the hand spray gun.
- Risk of falling! Take precautions when working on a scaffold, so that the person does not fall from the scaffold due to the recoil force generated by the appliance.
- For manual work with a spray gun, the nozzle diameter must be selected so that the recoil force in the longitudinal axis does not exceed 250 N during max. operating pressure. If the recoil force 150 N, the spray gun must be equipped with a body support as per European standard prEN 1829. With recoil forces that exceed 250 N, the nozzle must be guided mechanically.+
- The recoil forces may be different if you are using angular spray devices.
- Always monitor the displays during operation. If the displayed values are not correct, switch the appliance off immediately and remediate the cause of the malfunction.
- If the appliance is not to be turned on, e.g. during maintenance procedures, you must attach a warning sign on the switch cabinet.
- Prevent unauthorised personnel from using the appliance by switching off the key switch and removing the key.
- The appliance must be secured against unauthorised use during work breaks.
- If the water stream is directed on sound-amplifying objects, the noise emission values may exceed the values listed in the specifications.
- Any type of non-adherence as well as resulting injuries to humans and damage to materials lies in the responsibility of the operator. Failure to observe these warnings may result in injuries or death of the operating personnel.

Protective clothing

Danger

When working with the appliance or when being present near the spray unit, the following protective clothing must be worn:



Helmet with protective shield



Safety goggles



Capsule ear protection



Protective gloves



Special safety boots and a middle foot protection



Protective jacket/protective overalls



Note

You must use protective clothing that is specifically intended to be used with high pressure cleaners. Effective protective clothing can be purchased directly from KÄRCHER.

Safety Devices

Safety devices serve to protect the user and must not be rendered inoperational or their functions bypassed.

Emergency-stop button

To put all functions out of operation immediately: Press emergency-stop button. The appliance is free of pressure.

Safety switch for appliance hood

The appliance should be used only if the appliance hood is closed. If the appliance hood is opened during operation, the appliance will switch off and a fault will be displayed.

Burst disc

If the working pressure exceeds the max. permissible overpressure by approx. 10%, the burst disc will be destroyed and the water will circulate inside the appliance without pressure. High pressure operation no longer possible.





Pressure switch

The pressure switch switches off the appliance if the minimum prepressure is not reached.

High pressure sensor

The pressure sensor monitors the pressure buildup in the high pressure system. If the pressure sensor detects an exceedingly rapid pressure decrease, as might be the case with leaks or a burst hose, as well as if the working pressure is exceeded, the appliance will shut off.

Warning and instructive signs

	⚠ Danger <i>Risk of injury on account of electric shock!</i>
	⚠ Warning <i>Risk of burns on account of hot surfaces!</i>
	⚠ Warning <i>Danger of crushing. Do not remove the cover while the appliance is running. Do not reach near the cooling fan and the V-belt while the motor is running.</i>
	<p>→ Retighten the wheel bolts and the wheel nuts after driving 50 km to a torque of 100 Nm.</p> <p>→ Repeat the check after 500 km have been driven and after 50 operating hours.</p> <p>→ Repeat the safety checks at regular intervals.</p> <p>→ Have the brake system and the lighting system checked regularly by an authorised dealer workshop.</p>

Keep the warning and instructive signs on the appliance clean.

Replace damaged or missing warning and instructive signs with new ones.

Furthermore, the personnel must participate in a Kärcher safety seminar.

Function

The high pressure pump is driven by an intermediate gear by a diesel motor.

When the jet operation is interrupted, an electric signal will switch the system from hand spray gun to pressureless water circulation.

The preset operating pressure is regulated via the motor speed.

Environmental protection

Please arrange for the proper disposal of the old appliances



Old appliances contain valuable materials that can be recycled; these should be sent for recycling. Batteries, oil, and similar substances must not enter the environment. Please dispose of your old appliances using appropriate collection systems.

Please make sure that engine and gear oil, diesel and antifreeze

do not enter the environment. Protect the ground and dispose of used oil as well as fuel and antifreeze in an environmentally-clean manner.

Please do not release mineral oil containing wastewater

into the soil, surface waters or sewer systems.

Notes about the ingredients (REACH)

You will find current information about the ingredients at:

<http://www.karcher.de/de/unternehmen/umweltschutz/REACH.htm>

Proper use

Use this appliance only as directed in these operating instructions.

- The appliance is used to clean objects by means of a high pressure water jet with cold water without the use of detergents.
- The appliance may only be equipped with original accessories and spare parts.
- The appliance is not suited for the use in potentially explosive environments.
- The appliance is not suitable to be used simultaneously with multiple spray units.
- The fresh water supply must meet the following requirements:

max. temperature	60 °C
pH value	6,5...12
Total hardness	3...30 °dH
max. iron	0.2 mg/l Fe
max. manganese	0.05 mg/l Mn
max. chloride	100 mg/l Cl
max. organic substances	12 mg/l KMnO ₄ use
max. sulphate	100 mg/l SO ₄
max. chlorine	0,5 mg/l Cl ₂
min. dissolved oxygen	5 mg/l O ₂
max. abrasive hazardous substances	5 mg/l
free of undissolved gases	
max. conductivity	1000 µS/cm
remaining values as per DIN 50930	

Device elements

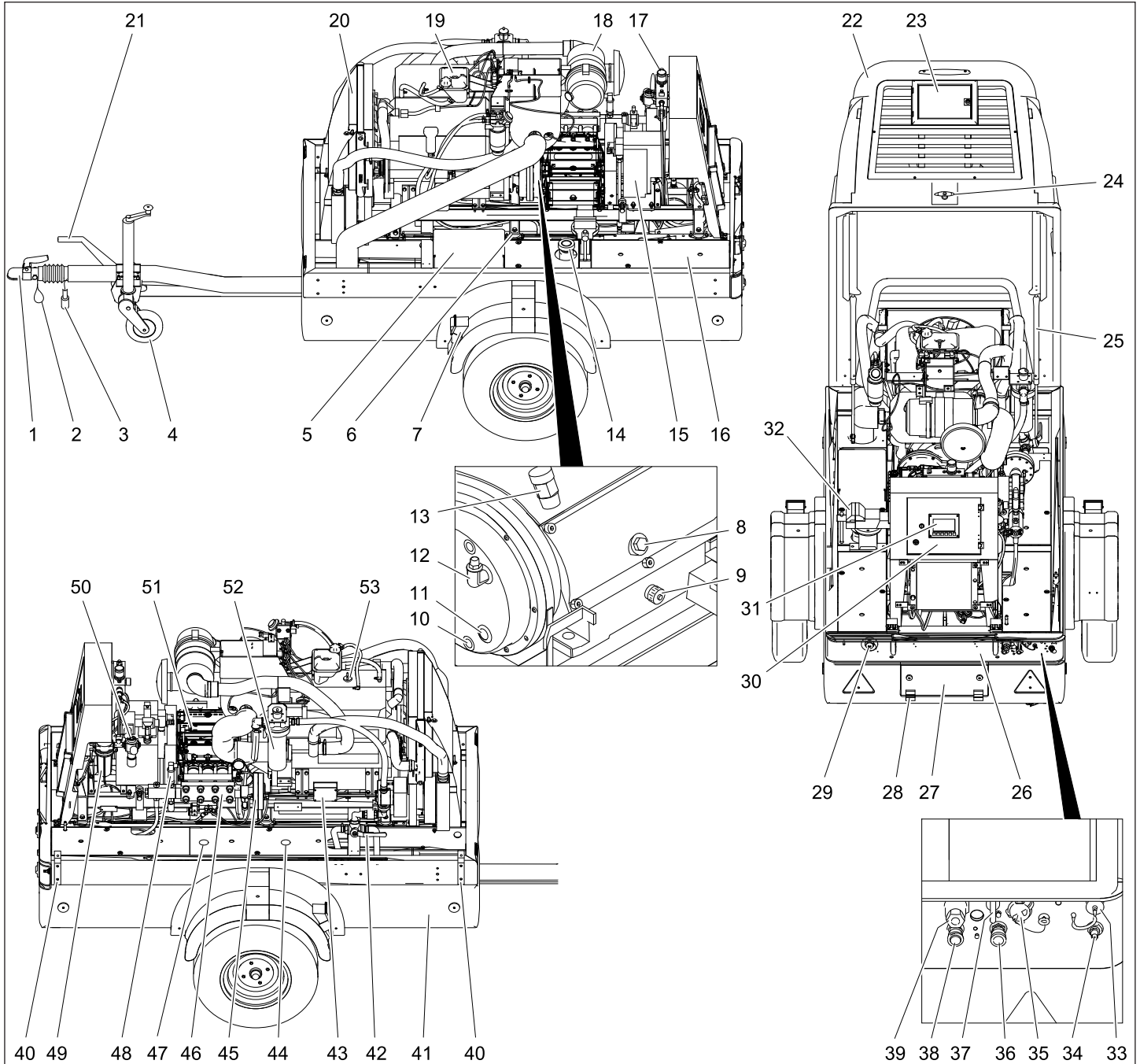

- | | | |
|---|--|---|
| 1 Towing hitch | 20 Radiator | 38 Left compressed air connection, to connect a compressed air tool |
| 2 Tear-off rope | 21 Parking brake | 39 High-pressure outlet |
| 3 Connector vehicle lighting | 22 Cover | 40 Lifting eyelet (option) |
| 4 Support wheel | 23 Door operating panel | 41 Drain tap of the water tank (inside the appliance) |
| 5 Battery | 24 Lock of appliance hood | 42 Ball tap, antifreeze/water tank |
| 6 Battery main switch | 25 Safety support appliance hood | 43 Main fuse |
| 7 Block wedge | 26 Registration plates | 44 Antifreeze container |
| 8 Oil dip pump gear | 27 Storage compartment | 45 Switch valve |
| 9 Covering lid, oil drain opening pump gear | 28 Hinge, storage compartment | 46 Pump head |
| 10 Oil drain screw intermediate gear | 29 Emergency-stop button | 47 Maintenance door water tank |
| 11 Oil sight glass intermediate gear | 30 Switch box | 48 Pressure sensor/high pressure |
| 12 Ventilation screw intermediate gear | 31 Operating field | 49 Maintenance unit, pneumatics (cyclone separator) |
| 13 Ventilation end gear | 32 Vice | 50 Manometer compressed air |
| 14 Filling nozzle diesel tank | 33 Socket, control line | 51 High pressure pump |
| 15 Compressor | 34 Exterior air connection (supply) | 52 Waterfilter |
| 16 Cover | 35 Water inlet | 53 Filler neck motor oil |
| 17 Compressed air valve | 36 Right compressed air connection, to connect a compressed air tool | |
| 18 Air filter | 37 Hose sock mounting | |
| 19 Equalising reservoir motor coolant | | |

Display and operating panel

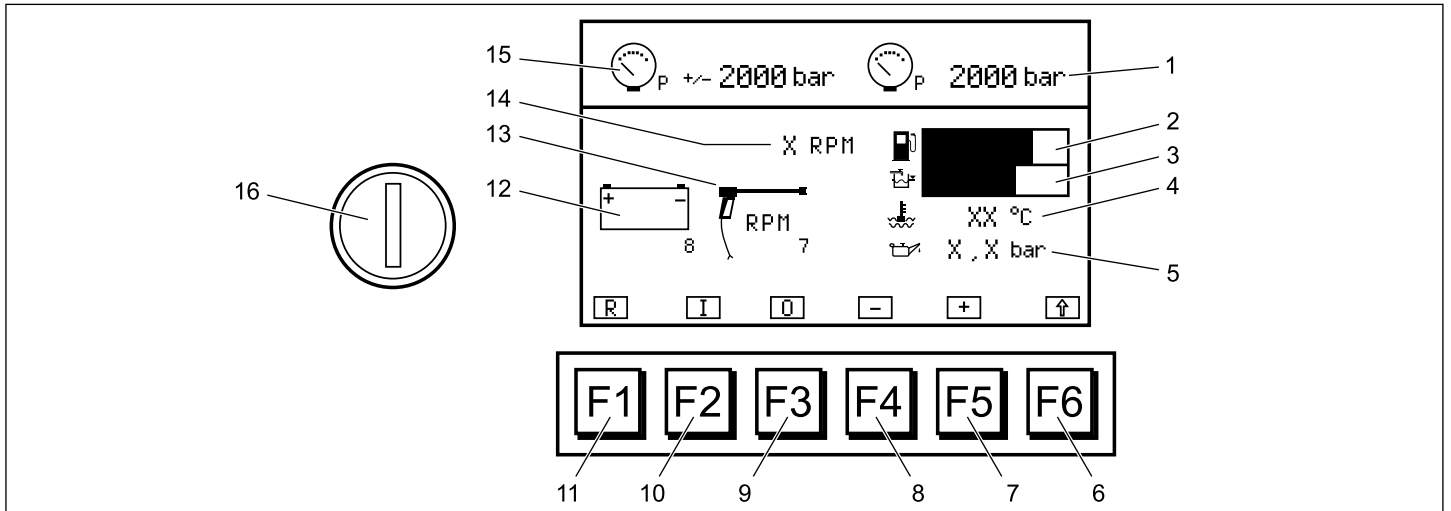

- | | | |
|-------------------------------------|--|-----------------------------|
| 1 Display actual pressure | 7 Key F5, increase nominal value | 13 Display operation |
| 2 Bar graph fuel level | 8 Key F4, decrease nominal value | 14 Display actual speed |
| 3 Bar graph water level in tank | 9 Key F3, motor OFF | 15 Display nominal pressure |
| 4 Display cooling water temperature | 10 Key F2, motor ON | 16 Key switch |
| 5 Display oil pressure | 11 Key F1, reset key (acknowledge fault) | |
| 6 F6 key, menu preselection | 12 Display appliance status | |

Symbols on the display

Symbol	Meaning
	Nominal pressure
	Actual pressure
	Motor oil pressure
	Fuel level
	Water level in tank
	Cool water temperature
	Reset
	Motor ON
	Motor OFF
	Reduce nominal value
	Increase nominal value
	Menu preselection

Symbol	Meaning
	Change value
	Brightness and contrast settings
	Informational display for service personnel (inputs/outputs, operating and high pressure hour-meter)
	List of faults
	Confirmation
	Triggering outputs
	High pressure hours
	Operating hours of motor
	Service interval hours motor
	Service interval hours pump
	Fault code motor
	Gun operation
	Gun operation with speed stop

Symbol	Meaning
	Antifreeze rinse operation
	Load control
	Display OK (control voltage ON or motor is running)
	Display wait time
	Preglowing (hold for 3 seconds)
	Nominal pressure reached

The symbols of the fault displays are described in the Chapter "Faults".

Hand spraygun

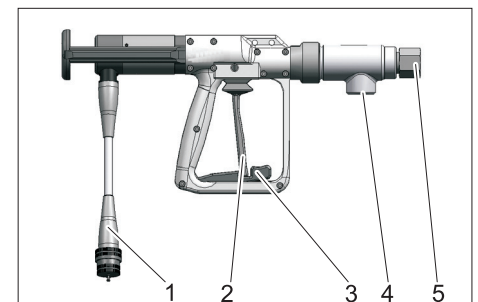

- 1 Coupling of the control cable
- 2 Lever
- 3 Locking
- 4 High pressure hose connection
- 5 Spray pipe connection

Operation

Please observe Chapter "Safety Instructions" and the enclosed safety instructions for high pressure cleaners (5.063-314.0)

Transport

Trailer operation

Note

The driver, who operates the towing vehicle with trailer on public roads must ensure that he has the appropriate license for this.

⚠ Danger

When transporting the trailer in public traffic with the water tank half full, the water can swap out or the trailer could even tilt during extreme steering manoeuvres.

- ➔ Completely fill or empty the water tank. Do not transport with the water tank half full.
- ➔ Close the appliance hood and openings.
- ➔ Adjust the height of the drawbar by means of the support wheel to the height of the trailer hitch of the towing vehicle.
- ➔ Attach the tear-off rope to the towing vehicle.

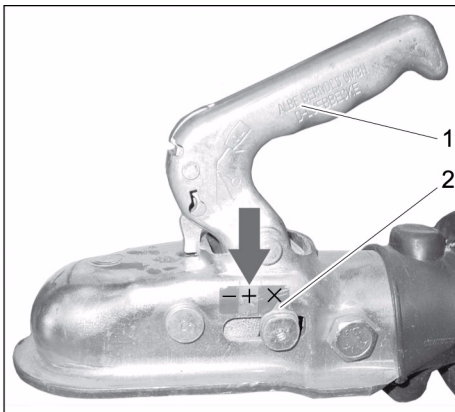

- 1 Coupling lever
- 2 Bolt with marking

- ➔ Hitch up the towing vehicle. Make sure that the marking on the bolt points to the + symbol (Pfeil) once the coupling lever is pushed down.
- ➔ Connect the connector of the vehicle lighting.
- ➔ Rotate the support wheel up by means of the crank.

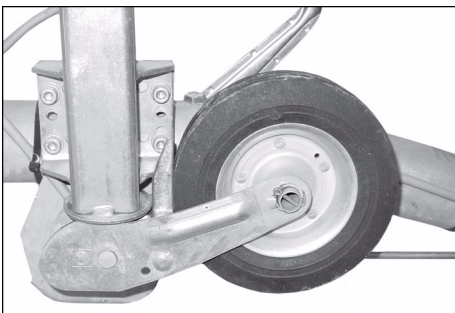

- ➔ Make sure that the support wheel points in the direction of the trailer when retracted.

- ➔ Remove the chocks from underneath the wheels and place them in their holders.
- ➔ Release parking brake.



- 1 Third brake light
- 2 Combined brake/tail lights, right, left
- 3 Blinker, right/left
- 4 Reverse light
- 5 License plate lighting
- 6 Fog lamp

- ➔ Check the brake lights, blinkers, tail lights, reverse lights, fog lamp and the license plate lighting for their function.
- ➔ Check tire pressure (refer to technical data).

Note

Local speed limits for vehicles with trailers must be observed and adhered to.

Loading

The appliance must be fitted with lifting eyelets (option) to be raised by means of a crane. The appliance should only be lifted by the lifting eyelets.

Setting up the appliance

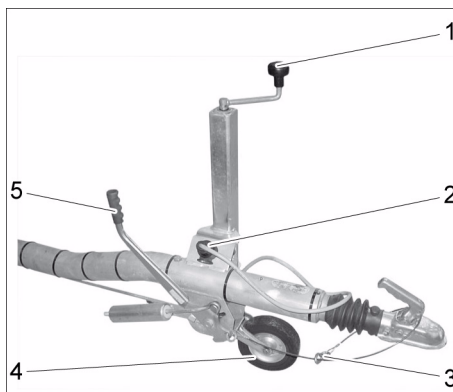

- 1 Crank to lower the support wheel
- 2 Connector vehicle lighting
- 3 Tear-off rope
- 4 Support wheel
- 5 Parking brake

- ➔ Lock parking brake.
- ➔ Lower the support wheel by means of the crank.
- ➔ Remove the tear-off rope from the towing vehicle.

- ➔ Disconnect the connector from the vehicle lighting and insert it into the plug storage on the drawbar.
- ➔ Secure the machine with wheel chocks to prevent it from rolling away.
- ➔ Disconnect the towing vehicle.
- ➔ Align the appliance horizontally with the support wheel.

Caution

Risk of malfunctions and damages to the appliance. The appliance must be in horizontal position during operation.

Preparing for start-up

Check the fill levels

- ➔ Open the lock on the appliance cover and swivel the appliance cover upwards.
- ➔ Swivel the latch of the appliance hood upwards to keep it from shutting inadvertently.
- ➔ Align the appliance horizontally

Check oil level in the pump, intermediate gear and motor

- ➔ Unscrew the oil dip on the pump gear.
- ➔ Wipe the oil dip with a lintfree cloth.
- ➔ Reinsert the dip completely and pull it back out.
- ➔ If the oil level has sunken to the mark, refill oil (see "Care and Maintenance").
- ➔ Check the oil level in the intermediate gear.
- ➔ The oil level must be in the centre of the viewing glass. If this is not the case, refill oil (see "Care and Maintenance").
- ➔ Pull out the oil dip of the motor.
- ➔ Wipe the oil dip with a lintfree cloth.
- ➔ Insert the oil dip, pull it out and read it.
- ➔ If the oil level has sunken to the mark, refill oil (see "Care and Maintenance").

Check the fill level of the coolant in the motor

- ➔ Check the fill level of the coolant in the equalisation container of the motor coolant with a cooled off motor. The liquid level has to be between MIN and MAX.

Check the fill level of the antifreeze

- ➔ In case of risk of frost, unscrew the lid of the antifreeze container and check the fill level. If required refill antifreeze.

Turning on the Appliance

- ➔ Switch on the battery main switch.
- ➔ Switch on the key switch on the operating panel.

Check the fill level of the diesel tank

⚠ Danger

Risk of explosion, fire, poisoning by means of exhaust gases.

- Turn the motor off prior to fueling up.
- Do not refuel in closed rooms, ensure sufficient ventilation.
- Never fill up in the vicinity of open flames or sparks.
- Do not smoke during fueling.
- Immediately remove fuel that leaked during the refuelling with cleaning cloths and dispose of it properly.

Caution

Do not completely deplete the fuel in the fuel tank, otherwise, the fuel system will have to be ventilated. Possibly suctioned dirt from the bottom of the tank can lead to malfunctions.

- Check the fill level of the diesel fuel at the bar segment display for the fuel level. If required, top off the diesel fuel. For temperatures below 0°, only use winter diesel.

Check the fill level in the water tank

- Check the fill level of the water at the bar segment display for the water level in the tank. Top off the water tank if necessary. Connect the water supply hose to the water inlet.

Start up

Connecting the spray pipe to the gun

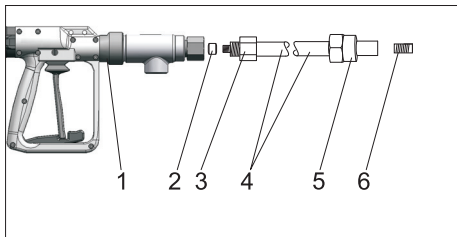

- 1 Trigger gun
- 2 Pressure ring
- 3 Pressure screw
- 4 Spray lance
- 5 Nozzle holder
- 6 High pressure nozzle

- Remove the protective caps on the spray pipe.
- Grease the thread on the gun side with stainless steel screw grease (6.280-180.0).
- Screw the pressure ring onto the spray pipe.

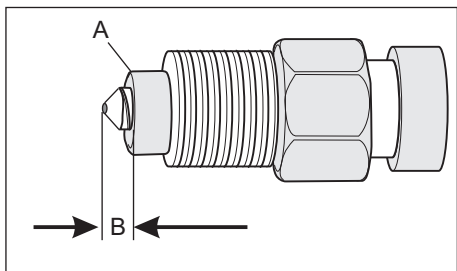

- The sealing cone of the spray pipe must protrude about 1-1.5 thread lengths (B) from the pressure ring (A).
- Rotate the pressure ring (A) by hand to adjust the distance (left thread).
- Insert the spray pipe all the way into the gun.
- Secure the spray pipe by tightening the pressure screw (torque approx. 100 Nm).

Connecting the nozzle

Do not perform this procedure until after the unit has been ventilated, see "Ventilating the high pressure system".

- Grease the thread on the nozzle side with stainless steel screw grease (6.280-180.0).

- Grease the nozzle holder with stainless steel screw grease (6.280-180.0) and screw it onto the spray pipe (left thread).
- Grease the thread of the high pressure nozzle with stainless steel screw grease (6.280-180.0) and screw it onto the nozzle holder (hexagon socket).

Connect the high pressure hose to the gun and the appliance.

⚠ Danger

Risk of injury from leaks or water jets emerging from leaks.

- Hoses, pipes and the spray unit must be in good condition and installed properly.
- Check the high pressure hose daily.
- Only use original high pressure hoses that are approved for the respective pressure range and temperature.
- Avoid contact with chemicals.
- Do not use hoses with kinks.
- Do not use the high pressure hose anymore if the thread is damaged or corroded.
- Stop using the high pressure hose if the external wire layer is visible.
- Do not route the high pressure hose across sharp edges.
- Lay the high pressure hoses in such a way that no vehicle can drive over it.
- Do not use high-pressure hoses that have been driven over, kinked, pressed or bent even if there is no externally visible damage.
- Completely lay out the high pressure hose, do not overlap.
- High pressure hoses age with time. Replace high pressure hoses every 6 years, even if they are in good condition.
- High pressure hoses that have been stored for more than 2 years, may no longer be used.
- Store the high pressure hose so that there is no mechanical strain. Store in a cool, dry and dustfree place.
- Do not stretch the high pressure hose during storage, as the high pressure hose might change its length during operation.
- Relieve tension from the high pressure hose after operation, purge excess water, coil it and store it properly.

- Unscrew the protective caps from the high pressure connection of the hand spray gun and pull off at the high pressure hose.
- Clean the thread and grease it with stainless steel screw grease (6.280-180.0).
- Check the high pressure hose for flawless condition (no damage). Only use intact hoses.
- Connect the high pressure hose to the hand spray gun (procedure as described in Chapter "Connecting the spray pipe to the gun").
- Remove the protective cap from the high pressure outlet of the appliance.

- Clean the thread and grease it with stainless steel screw grease (6.280-180.0).
- Connect the high pressure hose to high pressure connection (procedure as described in Chapter "Connecting the spray pipe to the gun").



- 1 Hose sock mounting
- 2 Hose sock

- When using a hose sock to protect the high pressure hose from ripping off, hook the hose sock into the hose sock mount.

Connect the control line

- Roll the control line off the winch to hose length. Make sure that the control line is not underneath the high pressure hose, as the high pressure hose can rub against it and cause a line break.
- Pull off the protective cap or antifreeze plug on the appliance connection side.
- Connect the short cable end of the winch with the socket.
- Plug the protective caps together to prevent soiling of the protective cap insides.
- Connect the control line on the gun side and plug the protective caps together.

Connect the water supply



According to the applicable regulations, the appliance must never be used on the drinking water net without a system separator. Use a suitable system separator manufactured by Kärcher, or, as an alternative, a system separator as per EN 12729 Type BA.

Note

Water with drinking water quality with a pressure between 0.15 and 0.6 MPa (1.5 to 6 bar) is required to ensure a smooth operation of the system.

- Remove the protective cap from the water supply inlet of the appliance.
- Connect the system separator to the water inlet (option).

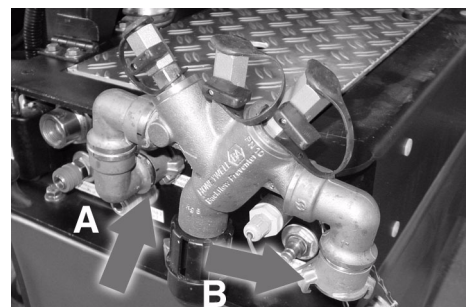

- A If the system separator was installed, the water inlet is on the appliance
- B Water inlet on the system separator

- Connect the water supply hose to the respective water inlet (arrow).
- Open the lock on the appliance cover and swivel the appliance cover upwards.
- Swivel the latch of the appliance hood upwards to keep it from shutting inadvertently.
- Check the water filter for contamination, clean/replace if required.

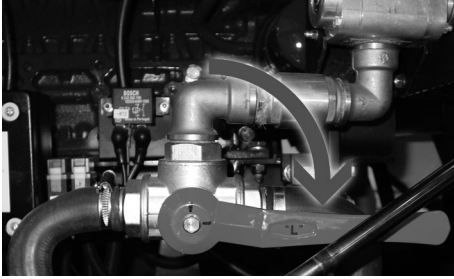

- Check the position of the ball tap in the antifreeze/water tank, set to the water tank on the right.

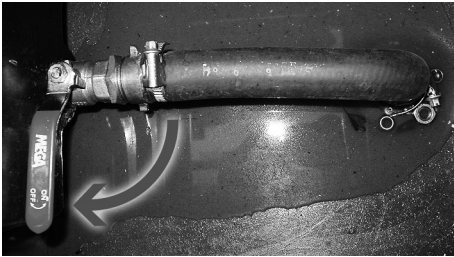

- Close the drain tap of the water tank.

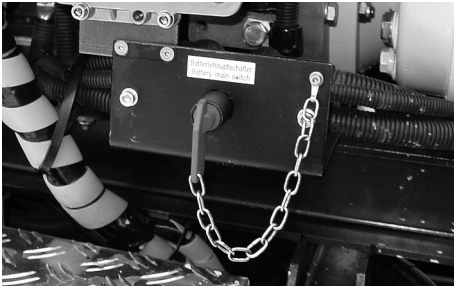

- Switch on the battery main switch.
- Tilt the safety latch of the appliance hood toward the bottom.
- Tilt the appliance hood downward and lock it.
- Open the door to the operating panel and switch on the ignition via the keys-switch.

If the tank level is low, the water will be supplied

Start the engine

Note

The appliance can only be operated with the appliance hood closed. The appliance will switch off when the appliance hood is opened.

- Release emergency-stop button by turning.
- Open the operating panel door.
- Turn the key switch to the right.

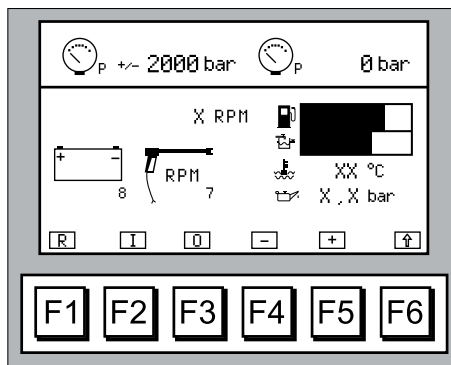

The control voltage is switch on and the display shows the operating status.

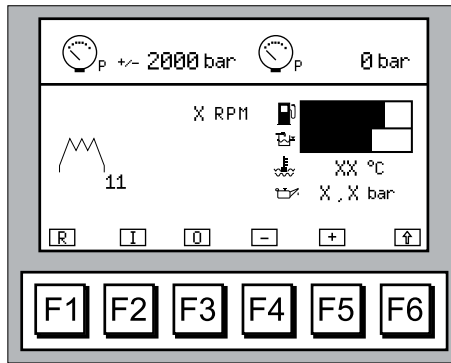

At low ambient temperatures, the preheating process will start automatically. The respective message is shown on the display.

- Press the F2 key to start the motor.

Motor runs warm.

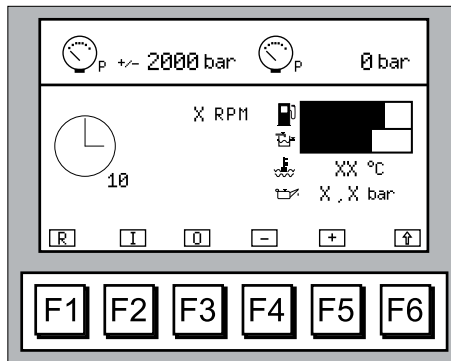

During the warm up time, the display will show the clock symbol.

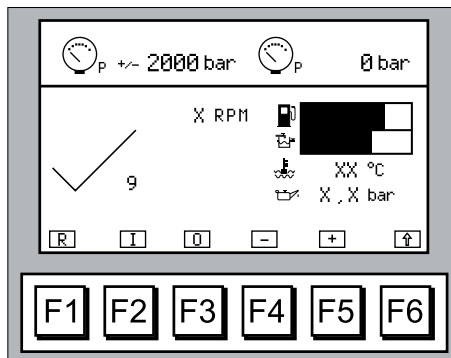

After the warm up time, the appliance will be ready for high pressure operation.

Ventilating the high pressure system

- Connect the high pressure hose, gun and the spray pipe without nozzle as described in chapter "Startup".
- Activate the gun about 30 to 40 seconds until a continuous water jet is emitted from the spray pipe.

- Switch off the motor.
- Install the nozzle as described in the chapter "Connecting the nozzle".

Settings

Adjust the water pressure

Note

The water pressure can be changed right after startup with the key switch as well as during operation.

- Adjust the water pressure using the F5 and F4 keys "Increase/reduce water pressure".

The water pressure can be changed in increments of 5 MPa (50 bar).

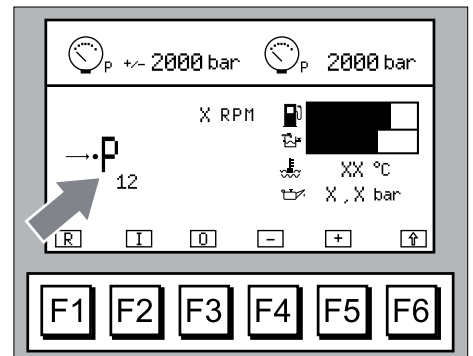

The set water pressure has been reached.

Adjust the brightness and contrast of the display

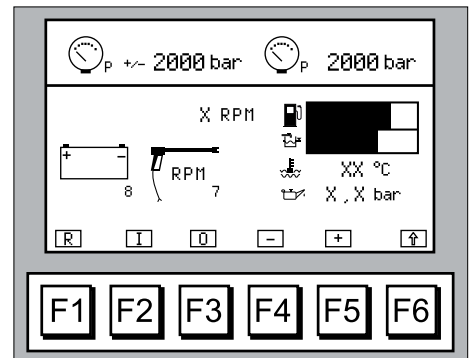

- Step 1: Press F6 key.

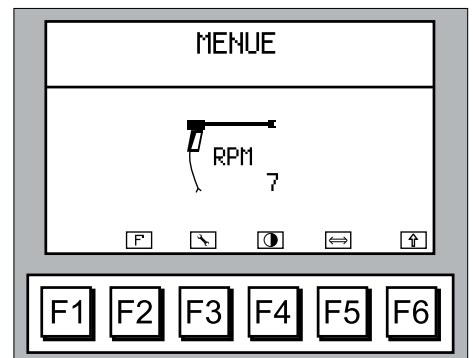

- Step 2: Press F4 key.

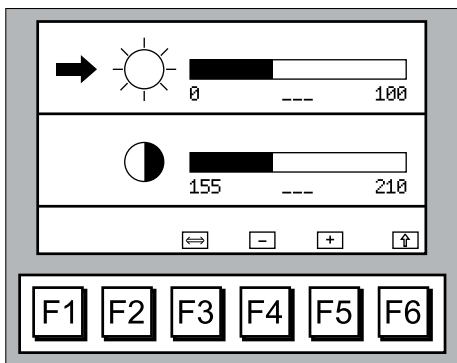

- ➔ Step 3: Press the F3 key to switch between brightness and contrast.
- ➔ You can change the brightness and contrast levels with the F4 and F5 keys. F4 (-) = set value decreases. F5 (+) = set value increases.
- ➔ By pressing the F6 key twice, you will return to the operating display.

Retrieve the informational display for service personnel

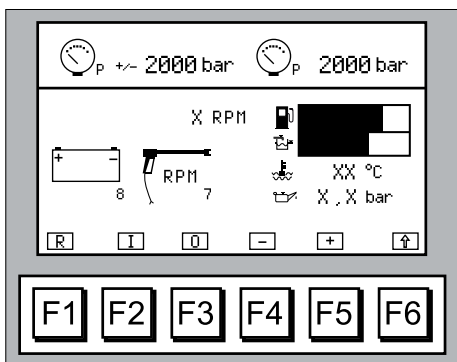

- ➔ Step 1: Press F6 key.

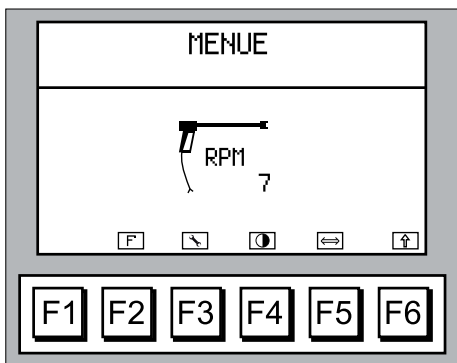

- ➔ Step 2: Press F3 key.

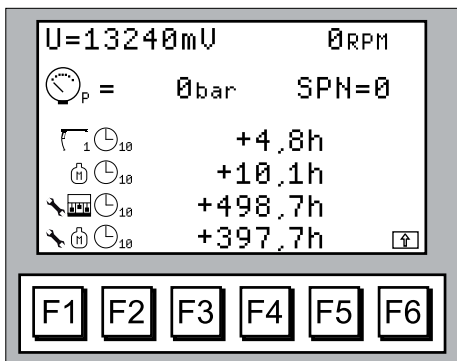

Different parameters can be read in the informational display:
 U = operating voltage
 RPM = motor speed
 bar = operating pressure
 h = operating hours

- ➔ By pressing the F6 key twice, you will return to the operating display.

Operation

Note

If the appliance is protected with antifreeze, this antifreeze must be purged from the water system (see chapter "Pumping antifreeze out of the water system"). Remove air from the high pressure system prior to operation!

- ➔ Press the release of the hand spray gun downwards.
- ➔ Pull the lever on the handgun toward the back. The motor goes to operating speed. The high pressure water stream is released.
- ➔ To switch off the high pressure spray, release the lever of the hand spray gun and let the release lock.

Note

Frequent switching on and off of the high pressure spray increase the wear and tear on the appliance and reduce its product life. Perform the cleaning process with as few interruptions as possible.

Shutting down

Note

Only use the Emerg Stop key in emergencies, not to switch off the appliance. A frequent use of the emergency stop key will increase wear and tear on the appliance.

- ➔ To switch off the high pressure spray, release the lever of the hand spray gun and let the release lock.
- ➔ Press F3 key. Depending on the load, the motor should somewhat longer to cool off.

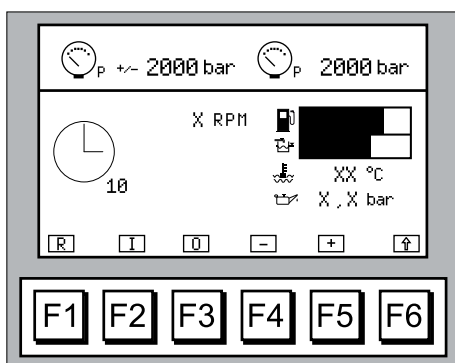

The display will show the trailing time of the motor with the clock symbol.

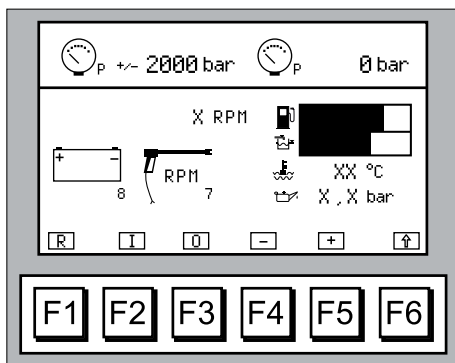

The motor will switch off.

- ➔ If there is a risk of freezing temperatures during the operational break, flush the appliance with antifreeze (see Chapter "Antifreeze") or transport the appliance to an area protected from frost.

- ➔ Turn main key to "0" and remove it.
- ➔ Close and lock the operating panel door.
- ➔ Open the hood and remove the key from the battery separating switch.
- ➔ Unscrew the high pressure hose, the water supply hose and the control line.
- ➔ Protect the hose connections and couplings from contamination with protective caps.

Note

Do not store any objects (incl. hoses, cables and spray units) inside the appliance. Use the storage compartment or storage box (option) to store these items.

Frost protection

Note

Use commercially available glycol-based antifreeze for automobiles. Observe the manufacturer's handling instructions.

To protect from freeze damages, the appliance must be flushed with antifreeze.

- Antifreeze flushing in a circuit from the antifreeze tank of the appliance, for preferred use on site

Antifreeze rinse in the circuit (high pressure pump)

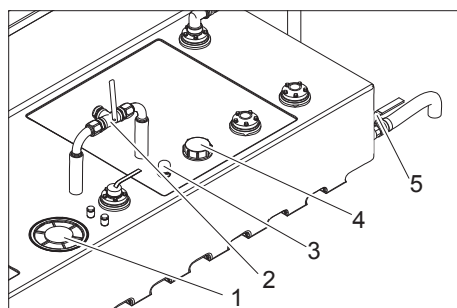

- 1 Maintenance door water tank
- 2 Ball tap, switchover antifreeze/water tank
- 3 Backflow antifreeze
- 4 Antifreeze container filler neck
- 5 Drain tap water tank



- 1 Antifreeze hose
- ➔ Unpressurize the appliance.

- Refill the antifreeze container with anti-freeze. Select the mixing ratio of the water/antifreeze as per the instructions of the antifreeze manufacturer.

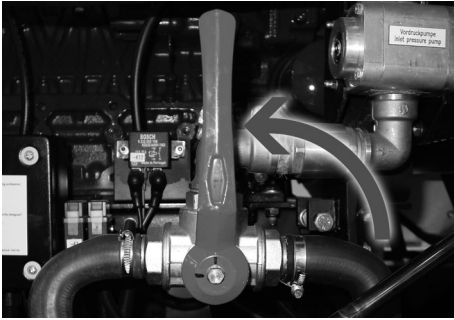

- Align the actuation lever of the ball tap for antifreeze/water tank vertically.
- Unscrew the high pressure hose from the high pressure outlet.

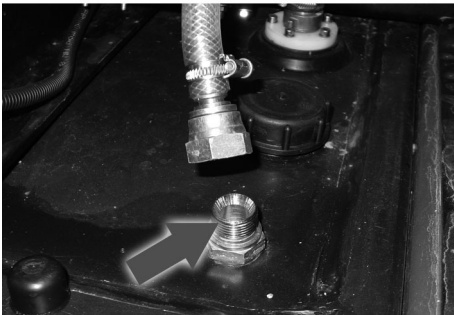
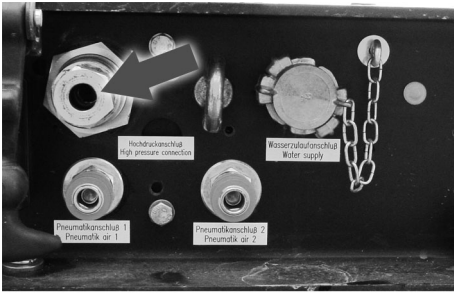

- Connect the antifreeze hose between the high pressure outlet and the anti-freeze return.



- Plug in the antifreeze plug control line.
- Turn the key switch to the right.

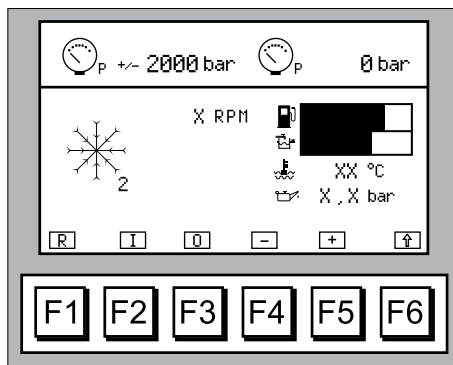

The control voltage is switched on and the display shows the antifreeze rinse operation.

- Press the F2 key to start the motor.
- Let the motor run until antifreeze is visible in the antifreeze hose.
The antifreeze liquid is pumped through the appliance in a circuit.

Note

After each antifreeze flush, the antifreeze concentration must be tested in the hose with a commercially available antifreeze tester in the return flow from the hose. Add more antifreeze as needed if the concentration is too low.

- Press the F3 key to shut off the motor. Wait for the motor to stop trailing.
- Remove the antifreeze hose between the high pressure outlet and the anti-freeze return.

Antifreeze motor

- Check the coolant circuit of the motor for sufficient antifreeze, refill antifreeze as needed.

See Maintenance Procedures "Check and refill the coolant".

Battery

- If the appliance is not used for an extended period and if there is frost, remove the battery and store it in a location protected from frost.

Pumping antifreeze out of the high pressure system

Note

Prior to operation, the antifreeze must be pumped from the high pressure system back into the antifreeze container.

- Unpressurize the appliance.

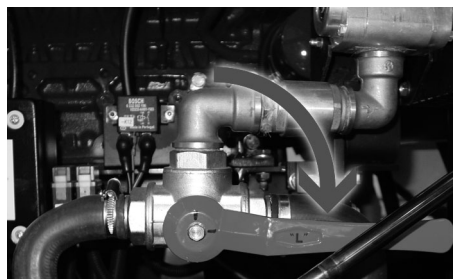

- Swivel the actuation lever of the ball tap for antifreeze/water tank to the right.

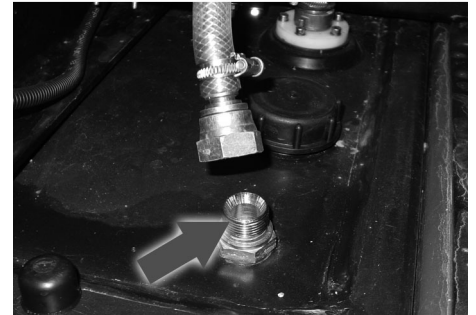
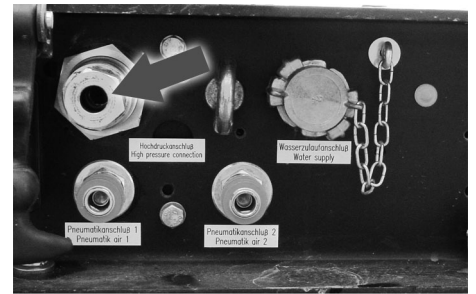

- Connect the antifreeze hose between the high pressure outlet and the anti-freeze return.
- Create a water supply connected to the system separator.
- Turn the key switch to the right.
The control voltage is switch on and the display shows the operating status.
The solenoid valve for the water supply will open.



- Plug in the antifreeze plug control line.
- Press the F2 key to start the motor.
- The antifreeze liquid is routed into the antifreeze tank with fresh water from the fresh water reservoir.
- Rinse for about 2 minutes. Watch the antifreeze hose until no more antifreeze can be seen.
- Press the F3 key to shut off the motor. Wait for the motor to stop trailing.
- Remove the antifreeze hose between the high pressure outlet and the anti-freeze return.

Maintenance and care

⚠ Danger

- Maintenance Procedures may only be carried out by persons who have been instructed in the safe operation and maintenance on the high-pressure systems.
 - Before carrying out any tasks on the machine, switch the key switch off and remove it.
- Prevent inadvertent startups of the appliance during Maintenance Procedures via third persons by attaching signs on the appliance and the spray unit.

- If the appliance must be started up for maintenance procedures, a second person must be present for safety reasons.
- Water under high pressure can penetrate the skin and cause severe injuries and infections. Stay away from leaks and do not search for leaks by hand.
- Do not use flammable detergents to clean the appliance.
- After completing the maintenance work, check all safety devices for correct installation and proper function.

⚠ Caution

Risk of damage. Do not disconnect the battery while the ignition is on or the motor is running.

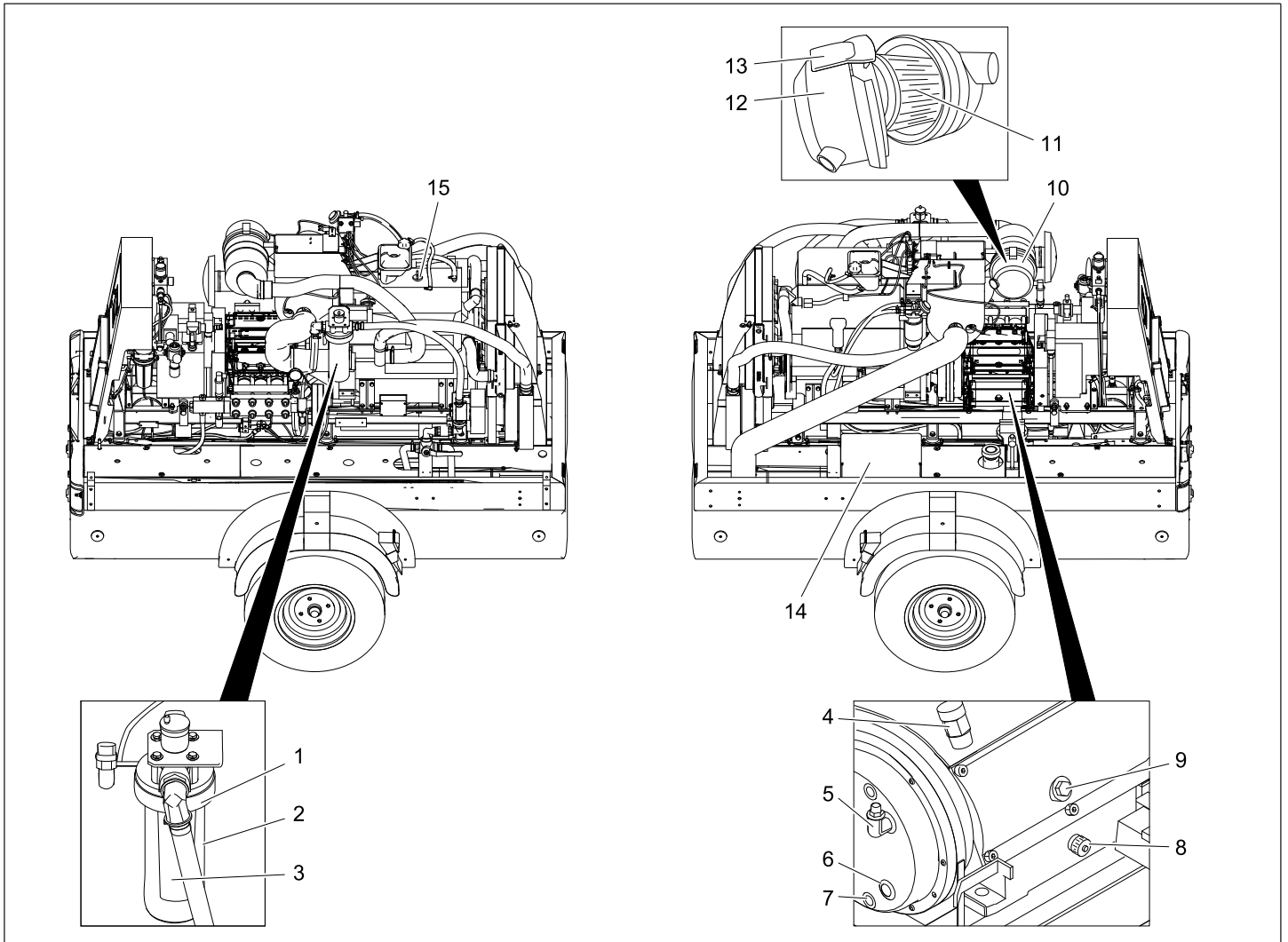

- 1 Waterfilter
- 2 Filter pot
- 3 Filter inlay
- 4 Ventilation of pump gear
- 5 Ventilation screw intermediate gear
- 6 Oil sight glass intermediate gear
- 7 Oil drain screw intermediate gear
- 8 Oil drain screw pump gear
- 9 Oil dip pump gear
- 10 Air filter
- 11 Air filter insert
- 12 Cover
- 13 Lock
- 14 Battery
- 15 Filler neck motor oil

Flow pattern

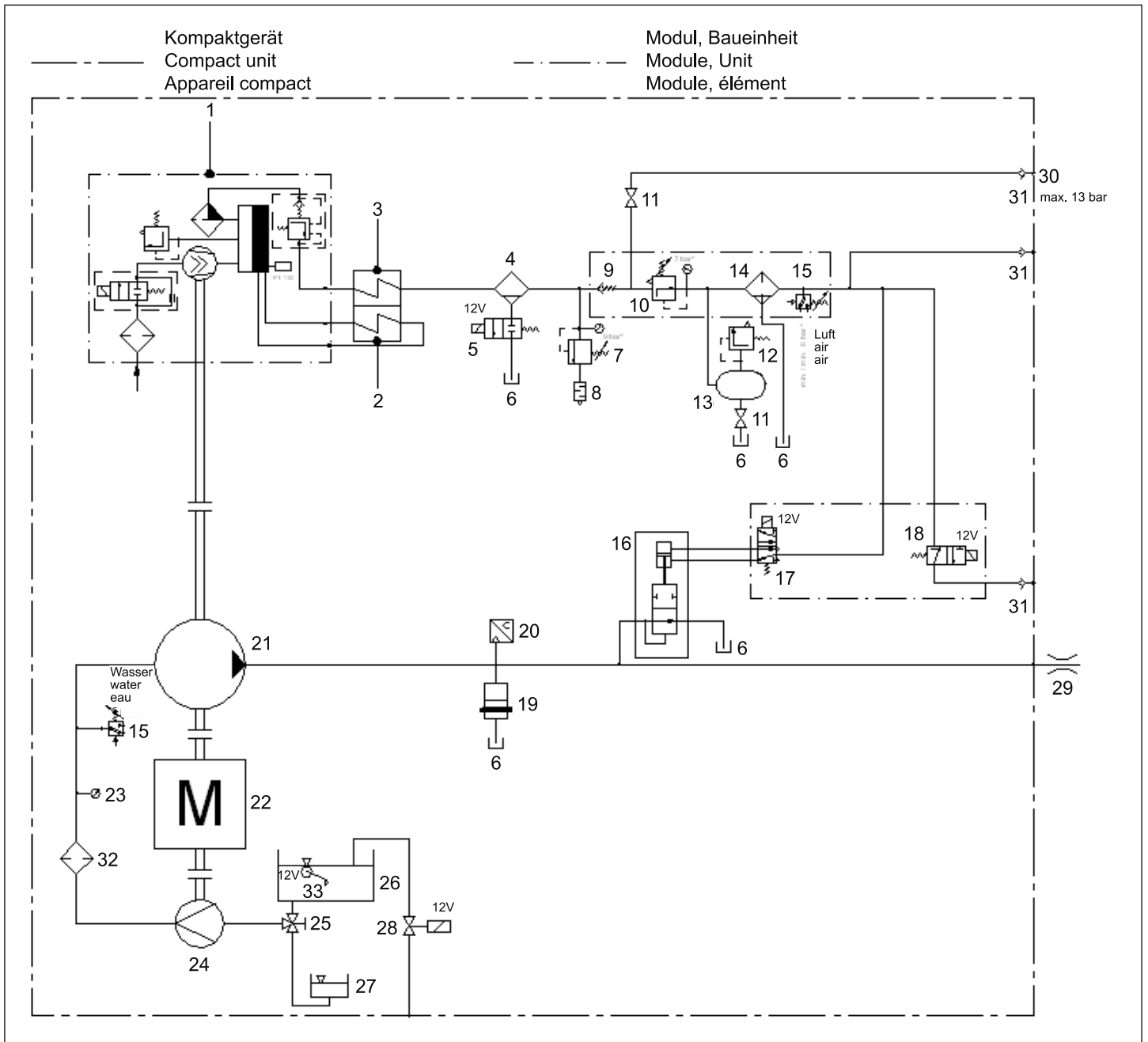

- | | |
|--|-------------------------------|
| 1 Compressor | 21 High-pressure pump |
| 2 Oil cooler module | 22 Internal combustion engine |
| 3 Air cooler module | 23 Prepressure manometer |
| 4 Cyclone separator | 24 Advance pressure pump |
| 5 2/2 way solenoid valve, 2-stroke | 25 Ball tap |
| 6 Condensation drain, return to water tank | 26 Water reservoir |
| 7 Pressure relief valve | 27 Antifreeze tank |
| 8 Silencer | 28 2/2 way solenoid valve |
| 9 Backflow valve | 29 High-pressure outlet |
| 10 Pressure regulation valve | 30 Exterior air |
| 11 Ball tap | 31 Quick coupling |
| 12 Safety valve | 32 Water filter |
| 13 Pressure container | 33 Fill level probe |
| 14 Compressed air filter | |
| 15 Pressure switch | |
| 16 2/2 way PN bypass valve | |
| 17 5/2 way valve | |
| 18 3/2 way valve | |
| 19 Burst disc safety | |
| 20 High pressure sensor | |

Maintenance intervals

Time	Activity	By whom
Prior to each drive	Check the lighting.	Operator
	Check the tyre pressure and their state.	Operator
Every 10 operating hours or daily	Check oil level in the pump gear (see "Initial startup"), refill oil if needed.	Operator
	Check the water filter and clean if necessary.	Operator
	Check coolant level in the equalisation container (see "Initial startup"), refill coolant if needed.	Operator
Once after the first 50 operating hours	Replace motor oil (see "Maintenance Procedures").	Customer Service
	Replace oil filter insert on motor.	Customer Service
	Check the screw connections on the motor. Call customer service if necessary.	Customer Service
Once after the first 150 operating hours	Replace oil in the pump gear.	Customer Service
	Replace oil in the intermediate gear.	Customer Service
Every 50 operating hours or weekly	Check pipes to see if there are any leaks.	Operator
	Check the V-belt tension, retension if necessary (see "Maintenance Procedures").	Customer Service/Operator
	Check hoses for wear, replace if required.	Customer Service/Operator
Every 100 operating hours	Check/clean the air filter insert (see "Maintenance Procedures").	Operator
	Check the screw connections on the motor. Call customer service if necessary.	Customer Service
Every 200 operating hours	Replace motor oil (see "Maintenance Procedures").	Customer Service
	Replace oil filter insert on motor.	Customer Service
Every 400 operating hours	Replace the fuel filter.	Customer Service
	Cleaning the water separator.	Customer Service
After 750 operating hours or once a year	Lubricate the brake on the drawbar (see "Maintenance Procedures").	Operator
	Replace air filter insert (see "Maintenance Procedures").	Customer Service
	Replace V-belt.	Customer Service
Every 1500 operating hours	Check the injection pressure at the fuel injector nozzle.	Customer Service
Every 3000 operating hours	Replace oil in the pump gear.	Customer Service
	Replace oil in the intermediate gear.	Customer Service
Every other year	Check the coolant in the motor and replace (see "Maintenance Procedures").	Customer Service/Operator

Maintenance Works

Check the oil level on the motor and add motor oil

Note

Only trained personnel is permitted to add motor, gear and pump oil.

Note

Align the appliance horizontally prior to check the oil level in order not to get a false result.

Check the oil prior to starting the appliance or at least 5 minutes after switching off the engine.

Caution

Increased risk of fire! When filling the motor oil make sure that no oil lands on hot motor surfaces.



- ➔ Remove the oil dip, wipe it and reinsert it.
- ➔ Remove the oil dip one more time and check the oil level.

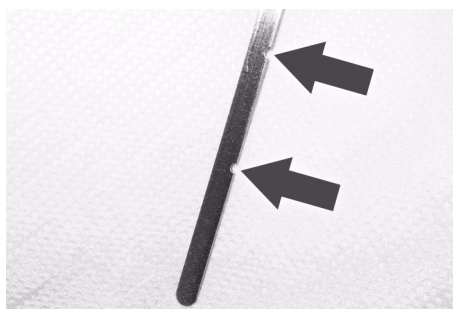

The oil level is correct if it is within the markings (arrows) on the oil dip.



- ➔ If the oil level is below the bottom mark, open the filler neck lid (arrow) and add fresh motor oil.

- ➔ Wait five minutes, until the oil has collected in the oil pan.
- ➔ Check the oil level as described above.
- ➔ Repeat this procedure as often as necessary until the oil level is between the markings on the oil dip.
- ➔ After the check, insert the oil dip and close the lid of the filler neck.

Oil change (to be performed by customer service only)

Note

Only trained personnel is permitted to add motor, gear and pump oil.

Note

Replace the oil while the motor has operating temperature. Align the appliance horizontally prior to the oil change.

Motor

Above 25 °C	SAE30 or SAE10W-30 SAE 15W-40
0 °C to 25 °C	SAE20 or SAE10W-30 SAE 15W-40
Below 0 °C	SAE10W or SAE10W-30 SAE15W-40

Pump and gear

Pump	Mobil D.T.E Oil AA 320
Gear	Mobil D.T.E Oil AA 320

- The oil level is correct if it is within the markings on the oil dip.
- After the check, insert the oil dip and close the lid of the filler neck.

Check the coolant and refill

Note

Prior to every operation, the fill level of the coolant in the equalisation container must be checked.

Caution

Observe the brand of antifreeze used. The mixture can cause a chemical reaction and hazardous substances can be generated. Do not mix different antifreeze types.

⚠ Warning

The motor can overheat if there is a lack of coolant. Turn the motor off immediately and let it cool down.

If the motor is so overheated, that water vapors escape, immediately turn the motor off and keep a safety distance to the motor until the pressure has decreased.

Danger of burns! Never open the lid on the cooler while the motor has operating temperature. The container is under pressure.

- Open the lid on the equalisation container of the motor coolant, fill in fresh clean water and the required antifreeze.

Cleaning/replacing the air filter



- Open both locks (arrows) on the lid.



- Remove the lid and the dust sediments.



- Take out the filter inlay.

- Blow out the filter insert with compressed air (max. 2 bar) from the inside.
- Clean the inside of the air filter housing with a cloth.

Note

Severely contaminated or defective filter inserts must always be replaced.

- Please the filter insert into the air filter housing with the closed side facing out.

Note

Make sure the lid fits snugly, if the lid does not close properly, dust can get into the combustion chamber of the motor and damage it.

- Replace the lid and close the locks.

Draining the compressed air system

Note

The compressed air system must be drained in regular intervals.

During continuous operation, it might be necessary to drain it 2 to 3 times a day.

Note

Do not drain the liquid from the system during high pressure operation. If the ball tap is open, pressure cannot be built up in the compressed air lines.



- Open the ball tap. Allow the water to drain.
- After the drain procedure, close the ball tap.

Compressor

Note

Maintenance work on the compressor may only be performed by the authorised customer service.

Charge/replace battery

⚠ Warning

Battery acid is very corrosive! Always wear acid-resistant goggles, gloves and an apron when working with battery acid.

Never charge the battery in the vicinity of open flames or igniting sparks.

The battery may only be charged in rooms that are sufficiently ventilated.

Depending on the battery type, the acid level might need to be checked.

The motor must be turned off to charge the battery.

Note

Prior to connecting the charger, the connecting cables to the control must be disconnected from the battery. Otherwise, the control could be damaged!

If the appliance is not used for an extended period and if there is frost, remove the battery and store it in a location protected from frost.

⚠ Warning

Never connect frozen batteries to charge them. Risk of explosion!

Prior to charging, thaw the battery and warm to at least 16 °C.

Note

When disconnecting the battery, first disconnect the negative and then the positive terminal.

When reconnecting the battery, first connect the positive and then the negative cable.

Do not transpose the connecting cable. Risk of cable fire!

- Disconnect the connecting cable from the battery at the negative terminal.
- Disconnect the connecting cable from the battery at the positive terminal.
- Connect the charger.
- Disconnect the charger after the charging process is complete.
- Connect the connecting cable to the positive terminal on the battery.
- Connect the connecting cable to the negative terminal on the battery.

Checking the V-Belt

Note

If the V-belt is not sufficiently tensioned, this can cause an overheating of the motor or to an insufficient battery charge.

- Shut off the motor and remove the key from the key switch.
- To check whether the V-belt is tensioned, press the belt with your thumb.

If the V-belt can easily be deflected, or if it sits loosely on the pulleys, you must order authorised customer service to tension/replace the V-belt.

Note

Defective V-belts must be replaced immediately.

Caution

The V-belt must only be tensioned or replaced by Customer Service.

Lubricate the brake on the drawbar

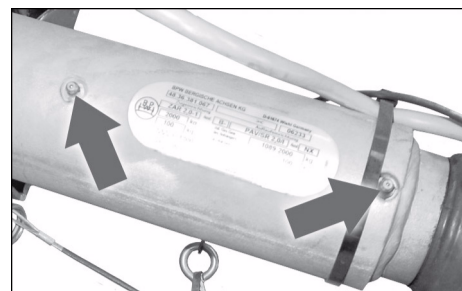

- Press lubricant into both lubrication nipples (arrows) using a commercial grease press.

Faults

⚠ Danger

This can lead to severe injuries and possibly death. An improper startup and repair of the appliance and the spray unit is dangerous.



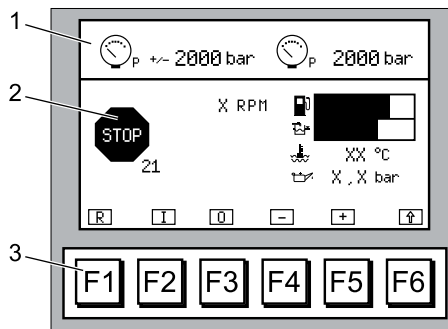

Faults with display







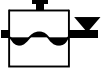
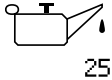

Faults detected by the control are shown on the display.



- 1 Display
- 2 Fault indication
- 3 Reset key to confirm the fault

- ➔ Read the fault message on the display and remediate the fault as per the table below.
- ➔ Press the reset button to acknowledge/confirm the fault message.

Display/meaning	Cause	Remedy	By whom	
 >Malfunction< EMERGENCY STOP	Emergency Stop switch depressed	Unlock Emergency Stop switch	Operator	
	Remote control not connected	Create connection	Operator	
	Plug wet	Dry the plug	Operator	
	Plug defective	Replace the plug	Customer Service	
	Switch in the hand spray gun defective	Check the switch, replace	Customer Service	
	Cable breakage	Replace the cable	Customer Service	
 >Malfunction< Hood open	Device hood open	Close appliance hood	Operator	
	Cable breakage	Replace the cable	Customer Service	
	Safety switch for appliance hood defective	Check safety switches.	Customer Service	
 >Malfunction< Tank level	Fuel tank empty.	Refill diesel fuel	Operator	
	Level sensor defective	Replace level sensor	Customer Service	
	Cable breakage	Replace the cable	Customer Service	
 >Malfunction< Cooling water level	See motor operating instructions			
	Level of coolant too low	Refill cooling water	Operator	
	Radiator contaminated	Clean the radiator	Operator	
	V-belt tension on the ventilator too low	Retension V-belt	Customer Service	
	Thermostat defective	Replace the thermostat	Customer Service	
	Cable breakage	Replace the cable	Customer Service	
 >Malfunction< Motor oil pressure	Motor oil level too low	Check the motor oil level	Operator	
	Oil the motor has the wrong viscosity	Replace engine oil.	Customer Service	
	Oil pressure switch on motor defective	Replace oil pressure switch on motor	Customer Service	
	Cable breakage	Replace the cable	Customer Service	
	Look for more instructions in the motor's operating instructions			
	 >Malfunction< Motor temperature	Coolant level in the motor too low	Check coolant units	Operator
Radiator contaminated		Clean the radiator	Operator	
V-belt tension on the ventilator drive too low		Check V-belt tension	Operator	
		Tighten V-Belt	Customer Service	
Thermostat defective		Check thermostat	Customer Service	
Defective temperature switch		Check the temperature switch	Customer Service	
Cable breakage		Replace the cable	Customer Service	
Look for more instructions in the motor's operating instructions				
 >Malfunction< Tyre pressure	Ball tap of drain open	Close the ball tap	Operator	
	Water in the compressed air tank	Drain water	Operator	
	Air system leaks	Seal the air system	Customer Service	
	Compressor defective	Repair the compressor	Customer Service	
	V-belt tension on the compressor drive too low	Tighten V-Belt	Customer Service	
	Pressure switch is defective	Check/replace the pressure switch	Customer Service	
	Cable breakage	Replace the cable	Customer Service	

Display/meaning	Cause	Remedy	By whom
 28 >Malfunction< High pressure sensor	Cable plug of high pressure sensor loose or short in connection	Check for correct fit	Operator
	Cable breakage	Replace the cable	Customer Service
	High pressure sensor defective	Check / replace the sensor	Customer Service
 29 >Malfunction< High pressureHochdruck > max.	The permitted max. pressure is exceeded due to small or plugged nozzle	Check the nozzle size, install correct nozzle	Operator
	Load speed too high	Reduce load speed	Customer Service
 30 >Malfunction< High pressure decrease too slow	The pressure decrease is too slow after the lever of the hand spray gun is released	Check the switch valve	Customer Service
	Cable breakage	Replace the cable	Customer Service
	High pressure valve defective	Check the high pressure valve	Customer Service
	High pressure sensor defective	Check / replace the sensor	Customer Service
 31 >Malfunction< Water level	Water tank empty. Inlet valve to water tank closed (by customer)	Check the inlet valve to the water tank	Operator
	Cross section of water supply hose too small	Use a water supply hose with a larger cross section	Operator
	Level switch defective	Replace the level switch	Customer Service
	Cable breakage	Replace the cable	Customer Service
 32 >Malfunction< Water inlet pressure below 0.15 MPa (1.5 bar)	Water reservoir empty	Filling the Water Reservoir	Operator
	Water filter contaminated	Clean water filter	Operator
	Backflow valve on the advance pump contaminated	Check backflow valve	Customer Service
	Pressure switch is defective	Check/replace the pressure switch	Customer Service
	Cable breakage	Replace the cable	Customer Service
	Advance pump defective	Check / replace the prepressure pump	Customer Service
	Advance pump drive defective	Check/replace the main switch	Customer Service
 33 >Malfunction< Remote control	Remote control not connected	Create connection	Operator
	Plug wet	Dry the plug	Operator
	Plug defective	Replace the plug	Customer Service
	Switch in the hand spray gun defective	Check the switch, replace	Customer Service
	Cable breakage or short in the control line	Check the cable, replace	Customer Service
 35 >Malfunction< EMR fault	See motor operating instructions		
	Evaluation unit defective	Replace evaluation unit	Customer Service
	Cable breakage	Replace the cable	Customer Service
 36 >Malfunction< Compressor temperature	Oil temperature too high	Check the oil temperature	Operator
	Temperature sensor defective	Replace the temperature sensor	Customer Service
	Cable breakage	Replace the cable	Customer Service
 37 >Malfunction< Water in fuel	See motor operating instructions		
	Water in fuel	Replace the fuel	Operator
	Cable breakage	Replace the cable	Customer Service

Faults without display on the console

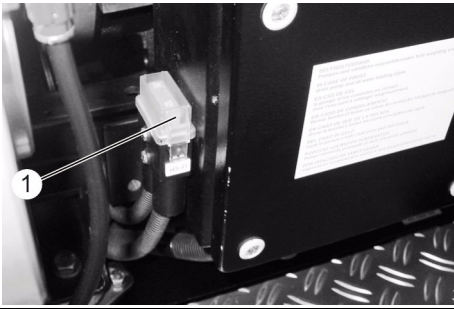

1 Main fuse

Fault	Cause	Remedy	By whom
Appliance stops, display switches off	Main fuse is blown	Replace the main fuse	Operator
No display after switching the appliance on	Battery main switch switched off	Switch on the battery main switch	Operator
	Battery depleted	Charging battery	Operator
	Main fuse is blown	Replace the main fuse	Operator
Motor will not start or turns off immediately	See separate operating instructions of the motor		
Working pressure is fluctuating	Air in the high pressure pump	Ventilating the high pressure system	Operator
	Valves worn out	Replace the valves	Customer Service

Technical specifications

		HD 7/250 DE TR1
Water connection		
Max. feed temperature	°C	60
Min. feed volume	l/h (l/min)	1080 (18)
Feed pressure	MPa (bar)	0,15...0,6 (1,5...6)
Performance data		
Water flow rate	l/h (l/min)	672 (11,2)
Operating pressure of water (using standard nozzle)	MPa (bar)	250 (2500)
Max. excess operating pressure (safety valve)	MPa (bar)	300 (3000)
Drive motor performance	kW	74
Motor rpm	1/min	3000
Battery	V/Ah	12/55
Nozzle size		0,6
Max. recoil force of hand spray gun	N	129
Fuel		
Oil quantity, intermediate gear	l	0,6
Oil type, intermediate gear	-	Mobil D.T.E. Oil AA 320
Oil quantity, pump gear	l	4,5
Oil type, pump gear	-	Mobil D.T.E. Oil AA 320
Oil quantity, motor	l	4,5
Oil type, motor	-	See Maintenance tasks
Content of cooling system	l	10-11
Dimensions and weights		
Length x width x height	mm	4068 x 1912 x 2000
Diesel tank	l	200
Weight without operating materials	kg	1240
Weight including operating materials, approx.	kg	1510
Permissible axle load	kg	1800
Antifreeze container	l	25
Water reservoir	l	200
Tyre type	-	205 R 14
Tyre pressure	MPa (bar)	0,45 (4,5)
Brake system	-	Overrun brake
Vibration total value (ISO 5349)		
Hand-arm vibration value		
Hand spraygun	m/s ²	<2,5
Spray lance	m/s ²	<2,5
Uncertainty K	m/s ²	0,5
Sound pressure level L _{pA} (EN 60704-1)	dB(A)	91
Uncertainty K _{pA}	dB(A)	2
Sound pressure level L _{WA} + Uncertainty K _{WA} (2001/14/EC)	dB(A)	111

Accessories and Spare Parts

- Only use accessories and spare parts which have been approved by the manufacturer. The exclusive use of original accessories and original spare parts ensures that the appliance can be operated safely and troublefree.
- At the end of the operating instructions you will find a selected list of spare parts that are often required.
- For additional information about spare parts, please go to the Service section at www.kaercher.com.

Warranty

The warranty terms published by the relevant sales company are applicable in each country. We will repair potential failures of your appliance within the warranty period free of charge, provided that such failure is caused by faulty material or defects in manufacturing. In the event of a warranty claim please contact your dealer or the nearest authorized Customer Service centre. Please submit the proof of purchase.

CE declaration

We hereby declare that the machine described below complies with the relevant basic safety and health requirements of the EU Directives, both in its basic design and construction as well as in the version put into circulation by us. This declaration shall cease to be valid if the machine is modified without our prior approval.

Product: Maximum pressure cleaners

Type: 1.025-xxx

Relevant EU Directives

2006/42/EC (+2009/127/EC)

2004/108/EC

2000/14/EC

Applied harmonized standards

EN ISO 12100-1

EN ISO 12100-2

pr EN 1829-1

EN 1829 -2

EN 13309: 2000

EN 55012: 2007 + A1: 2009

Applied conformity evaluation method

2000/14/EC: Appendix V

Sound power level dB(A)

Measured: 109

Guaranteed: 111

The undersigned act on behalf and under the power of attorney of the company management.

H. Jenner
CEO

S. Reiser
Head of Approbation

Authorised Documentation Representative
S. Reiser

Alfred Kärcher GmbH Co. KG
Alfred-Kärcher-Str. 28 - 40
71364 Winnenden (Germany)
Phone: +49 7195 14-0
Fax: +49 7195 14-2212
Winnenden, 2010/08/01

AE Kärcher FZE, P.O. Box 17416, Jebel Ali Free Zone (South), Dubai, United Arab Emirates,
☎+971 4 886-1177, www.kaercher.com

AR Kärcher S.A., Uruguay 2887 (1646) San Fernando, Pcia. de Buenos Aires
☎+54-11 4506 3343, www.karcher.com.ar

AT Alfred Kärcher Ges.m.b.H., Lichtblaustraße 7, 1220 Wien,
☎+43-1-25060-0, www.kaercher.at

AU Kärcher Pty. Ltd., 40 Koornang Road, Scoresby VIC 3179, Victoria,
☎+61-3-9765-2300, www.karcher.com.au

BE Kärcher N.V., Industrieweg 12, 2320 Hoogstraten,
☎+32-3-340 07 11, www.karcher.be

BR Kärcher Indústria e Comércio Ltda., Av. Professor Benedito Montenegro no 419, Betel, Paulínia - Estado de Sao Paulo, CEP 13.140-000
☎+55-19-3884-9100, www.karcher.com.br

CA Kärcher Canada Inc., 6535 Millcreek Road, Unit 67, Mississauga, ON, L5N 2M2,
☎+1-905-672-8233, www.karcher.ca

CH Kärcher AG, Industriestrasse, 8108 Dällikon, Kärcher SA, Croix du Péage, 1029 Villars-Ste-Croix,
☎0844 850 864, www.kaercher.ch

CN Kärcher (Shanghai) Cleaning Systems, Co., Ltd., Part F, 2nd Floor, Building 17, No. 33, XI YA Road, Waigaogiao Free Trade, Pudong, Shanghai, 200131
☎+86-21 5076 8018, www.karcher.cn

CZ Kärcher spol. s r.o., Modletice c.p. 141, CZ-251 01 Ricany,
☎+420/323/606 014, www.kaercher.cz

DE Alfred Kärcher Vertriebs-GmbH, Friedrich-List-Straße 4, 71364 Winnenden,
☎+49-7195/903-0, www.kaercher.de

DK Kärcher Rengøringsystemer A/S, Helge Nielsens Allé 7 A, 8723 Løsning,
☎+45-70206667, www.karcher.dk

ES Kärcher, S.A., Pol. Industrial Font del Radium, Calle Josep Trueta, 6-7, 08403 Granollers (Barcelona),
☎+34-902 17 00 68, www.karcher.es

F Kärcher S.A.S., 5, avenue des Coquelicots, Z.A. des Petits Carreaux, 94865 Bonneuil-sur-Marne,
☎+33-1-4399-6770, www.karcher.fr

FI Kärcher OY, Yrittäjätie 17, 01800 Klaukkala,
☎+358-207 413 600, www.karcher.fi

GB Kärcher (U.K.) Ltd., Kärcher House, Beaumont Road, Banbury, Oxon OX16 1TB,
☎+44-1295-752-000, www.karcher.co.uk

GR Kärcher Cleaning Systems A.E., 31-33, Nikitara str. & Konstantinoupoleos str., 136 71 Aharnes,
☎+30-210-2316-153, www.karcher.gr

HK Kärcher Limited, Unit 10, 17/F., Apec Plaza, 49 Hoi Yuen Road, Kwun Tong, Kowloon,
☎++(852)-2357-5863, www.karcher.com.hk

HU Kärcher Hungaria KFT, Tormásrét ut 2., (Vendelpark), 2051 Biatorbagy,
☎+36-23-530-64-0, www.kaercher.hu

I Kärcher S.p.A., Via A. Vespucci 19, 21013 Gallarate (VA),
☎+39-848-998877, www.karcher.it

IE Kärcher Limited (Ireland), 12 Willow Business Park, Nangor Road, Dublin 12,
☎(01) 409 7777, www.kaercher.ie

JP Kärcher (Japan) Co., Ltd., Irene Kärcher Building, No. 2, Matsusaka-Daira 3-chome, Taiwa-cho, Kurokawa-gun, Miyagi 981-3408,
☎+81-22-344-3140, www.karcher.co.jp

KR Karcher Co. Ltd. (South Korea), 2nd Floor, Youngjae Building, 50-1, 51-1, Sansoo-dong, Mapo-ku, Seoul 121-060,
☎+82-2-322 6598, www.karcher.co.kr

MX Karcher México, SA de CV, Av. Gustavo Baz Sur No. 29-C, Col. Naucalpan Centro, Naucalpan, Edo. de México, C.P. 53000 México,
☎+52-55-5357-04-28, www.karcher.com.mx

MY Karcher Cleaning Systems Sdn. Bhd., 71 & 73 Jalan TPK 2/8, Taman Perindustrian Kinrara, Seksyen 2, 47100 Puchong, Selangor Darul Ehsan, Malaysia,
☎+603 8073 3000, www.karcher.com.my

NL Kärcher B.V., Postbus 474, 4870 AL Etten-Leur,
☎0900-33 666 33, www.karcher.nl

NO Kärcher AS, Stanseveien 31, 0976 Oslo, Norway,
☎+47 815 20 600, www.karcher.no

NZ Karcher Limited, 12 Ron Driver Place, East Tamaki, Auckland, New Zealand,
☎+64 (9) 274-4603, www.karcher.co.nz

PL Kärcher Sp. z o.o., Ul. Stawowa 140, 31-346 Kraków,
☎+48-12-6397-222, www.karcher.pl

RO Karcher Romania srl, Sos. Odaii 439, Sector 1, RO-013606 BUKAREST,
☎+40 37 2709001, www.kaercher.ro

RU Karcher Ltd. Service Center, Leningradsky avenue, 68, Building 2, Moscow, 125315
☎+7-495 789 90 76, www.karcher.ru

SE Kärcher AB, Tagenevägen 31, 42502 Hisings-Kärä,
☎+46 (0)31-577 300, www.karcher.se

SGP Karcher South East Asia Pte. Ltd., 5 Toh Guan Road East, #01-00 Freight Links Express Distripark, Singapore 608831,
☎+65-6897-1811, www.karcher.com.sg

SK Kärcher Slovakia, s.r.o., Beniakovä 2, SK-94901 NITRA,
☎+421 37 6555 798, www.kaercher.sk

TR Kärcher Servis Ticaret A.S., 9 Eylül Mahallesi, 307 Sokak No. 6, Gazimir / Izmir,
☎+90-232-252-0708, +90-232-251-3578, www.karcher.com.tr

TW Karcher Limited, 7/F, No. 66, Zhongjijheng Rd., Sinjhuang City, Taipei County 24243, Taiwan,
☎+886-2-2991-5533, +886-800-666-825, www.karcher.com.tw

UA Kärcher TOV, Kilzeva doroga, 9, 03191 Kiev,
☎+380 44 594 7576, www.karcher.com.ua

USA To locate your local dealer please visit our web site at <http://www.karchercommercial.com> or call us at 888.805.9852

ZA Kärcher (Pty) Ltd., 144 Kuschke Street, Meadowdale, Edenvale, 1614,
☎+27-11-574-5360, www.karcher.co.za

Free Manuals Download Website

<http://myh66.com>

<http://usermanuals.us>

<http://www.somanuals.com>

<http://www.4manuals.cc>

<http://www.manual-lib.com>

<http://www.404manual.com>

<http://www.luxmanual.com>

<http://aubethermostatmanual.com>

Golf course search by state

<http://golfingnear.com>

Email search by domain

<http://emailbydomain.com>

Auto manuals search

<http://auto.somanuals.com>

TV manuals search

<http://tv.somanuals.com>