

## Operating Instructions

### WATERCLEAN 600 LP / MP



BTA 5.960-505.0

ETL 5.970-054.0 (LP 400V)  
5.970-055.0 (MP 400V)  
5.970-156.0 (LP 230V)  
5.970-157.0 (MP 230V)

A 2011201

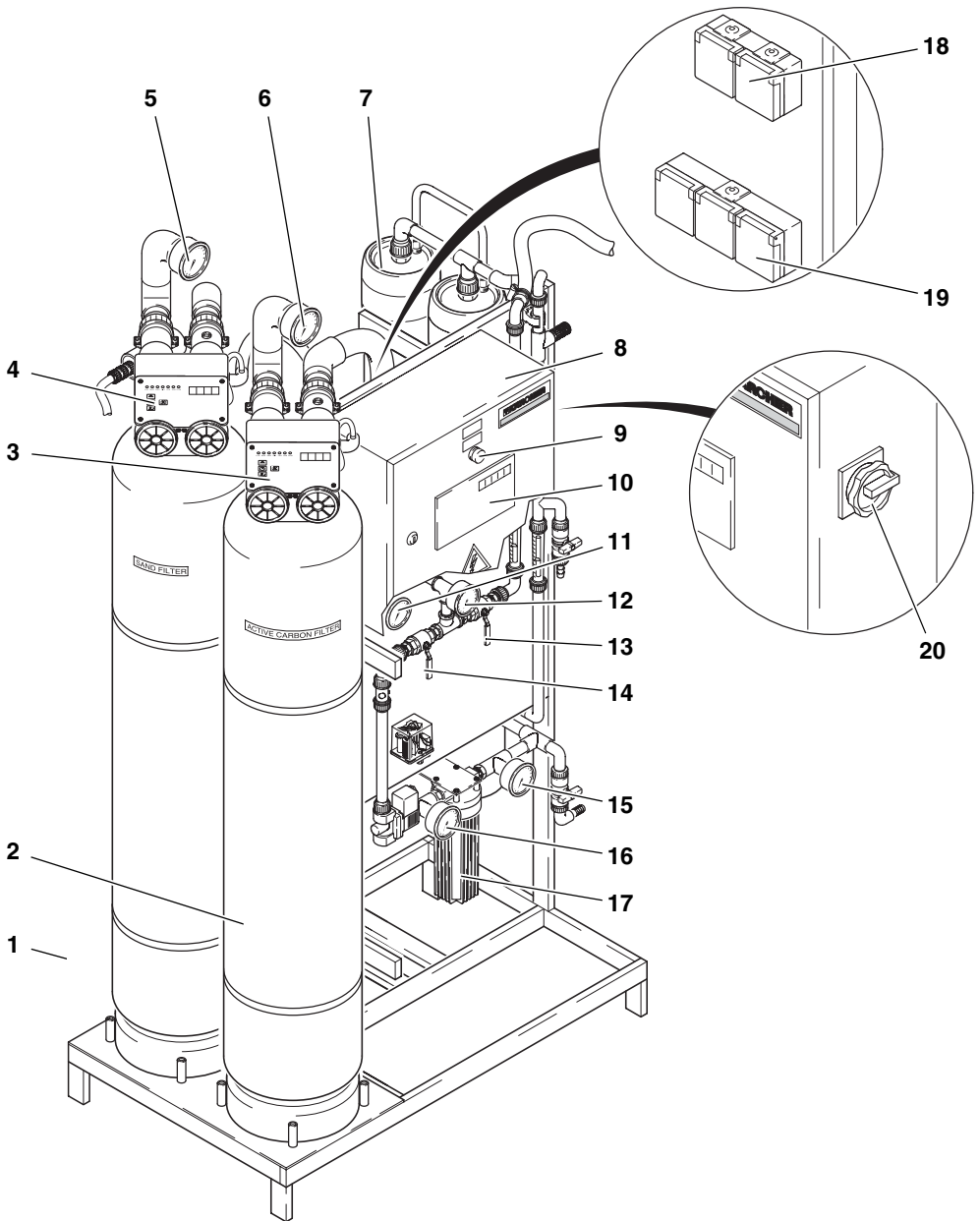

**Contents**

1 Safety Notes .....3  
 2 Intended Use .....3  
 3 Maintenance and Care .....4  
 3.1 Starting Operation .....4  
 3.1.1 Admission-pressure Unit .....4  
 3.1.2 Filling the Metering Stations .....4  
 3.1.3 Switching On the Equipment .....5  
 3.1.4 Operating Indicators .....5  
 3.2 During Operation .....5  
 3.2.1 Control and Corrective Action Intervals..5  
 3.2.2 Sand and Activated Carbon Filter .....6  
 3.2.3 Bleeding the Metering Pump .....6  
 3.2.4 Replacing the Fine Filter .....7  
 3.2.5 Fine Adjustment of the Operating Pressures .....7  
 3.2.6 Mixing the Chemicals .....8  
 3.3 Switching Off the Equipment .....9  
 4 Consumption Materials.....9  
 5 Malfunctions .....10  
 6 Technical Data .....11  
 7 EU Declaration of Conformity .....12

**Equipment Components**

- 1 Sand filter
- 2 Activated carbon filter
- 3 Control, activated carbon filter
- 4 Control, sand filter
- 5 Manometer, sand filter supply pressure
- 6 Manometer, activated carbon filter supply pressure
- 7 RO filter unit
- 8 Switch box
- 9 Operating mode switch
- 10 Control panel
- 11 Manometer, pump pressure
- 12 Manometer, concentrate pressure
- 13 Concentrate control valve
- 14 Pressure control valve
- 15 Manometer, fine filter supply pressure
- 16 Manometer, fine filter output pressure
- 17 Fine filter unit
- 18 Power outlets, sand and activated carbon filter
- 19 Power outlets (3x) for metering stations
- 20 Main switch

**1 Safety Notes**



Safe operation of the equipment is possible only when the operating instructions and safety notes are read completely, and the instructions contained therein are strictly followed.

**Drinking Water**

- Drinking water quality is ensured only when the equipment is controlled within the scheduled periods. Observe the given control intervals.
- Have the drinking water quality checked in regular intervals; the valid drinking water regulations are to be observed.

**Chemicals**

- Wear acid-resistant protective clothing (goggles and gloves).
- Store chemicals cool and dry, however, not below 5 °C.
- Keep chemicals at locations not accessible for children.
- Ensure good room ventilation and provide a washing facility.
- Have eye wash bottle readily available.

**Electrical Equipment**

- Work on the electrical equipment is to be carried out only by skilled persons for electrical work.
- Never touch damaged or cut through mains cables; pull the mains plug immediately, as required.
- Never operate the equipment with a damaged cable.

**2 Intended Use**

The equipment is used for conditioning of surface water, well water and river water.

Depending on the untreated water quality, the modular set-up enables secure separation of turbid materials, water hardeners, salts and bacteria/virus.

## 3 Maintenance and Care



The equipment may be put into operation only when set-up, installed and prepared for operation by an authorized **KÄRCHER specialist dealer**.

### 3.1 Starting Operation

Before starting operation:

- Make sure that the equipment is connected to the untreated water source and the respective transporting gear, e. g., admission-pressure unit.
- Ensure the unrestricted flow of the drinking water into a tank or a suitable device on the user side.



The drinking water must be able to run off without counterpressure. The height difference must not exceed 3 m.

#### 3.1.1 Admission-pressure Unit



In case an admission-pressure unit is necessary, it will be installed by a Kärcher service technician.

The admission-pressure unit consists of a pump (21) and a control device (22). The operating condition of the pump is indicated with three indicator lights:

- Green (24): Ready for operation
- Yellow (25): Pump delivering
- Red (26): Malfunction or water low

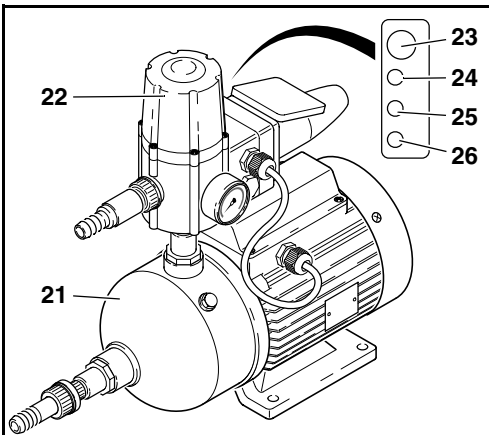

- The reset button (23) starts the pump after failure

#### 3.1.2 Filling the Metering Stations



If the system is equipped with one or more metering stations, it must be ensured that these are correctly filled and connected.

- Put on protective clothing.
- Open the lid (27) of the metering station (30).

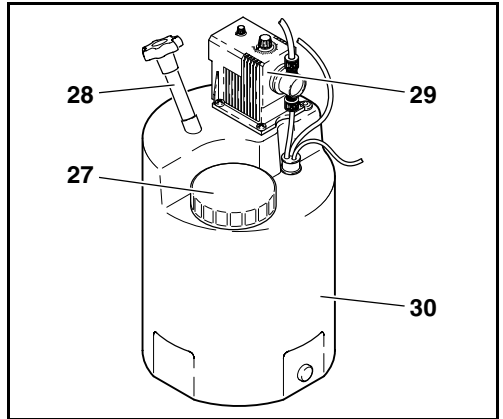

- Fill the respective chemical into the metering station according to Section 3.2.6.



The metering stations must not be mixed up or mistaken, meaning filled with the wrong chemical.

- Add the corresponding amount of chlorine-free drinking water.
- Shut the lid of the metering station.
- Pull the mixing rod (28) out of the metering station to the stop and push back in again. Repeat this procedure for approx. 5 minutes until the chemical is completely mixed.



If the metering container was completely empty, the metering pump (29) may have possibly drawn in air. In this case, bleed the air from the pump as described in Section 3.2.3.

### 3.1.3 Switching On the Equipment

- Check if the pumps of the metering station, sand and activated carbon filter are connected to the respective power outlets (18 / 19) at the switch box (8).
- Check if the operating mode switch (9) is in the correct position “Automatic” or “Hand”.



In the “Automatic” operating mode, the system is controlled via an external float switch in the drinking water tank.

In the “Hand” operating mode, the system is switched on and off manually via the main switch.

- Switch the main switch (20) to the “I” position; the system starts the drinking water production.

### 3.1.4 Operating Indicators

Display of the controls (3 / 4) of the **sand and activated carbon filters**:

- Display of the time
- LED line: Display of the weekday

Control of the **RO system**:

The following is alternately indicated on the two-line display of the control panel (10) of the RO system:

- Equipment/model No. and operating condition,
- Drinking water temperature and drinking water conductance value,
- Operating hours (\_ \_ \_ \_ \_h \_ \_min).

## 3.2 During Operation



Drinking water quality is ensured only when the following control intervals are met. In case deviations from the desired condition can not be eliminated through the measures mentioned, the drinking water production must be stopped and the Kärcher Service must be notified.

### 3.2.1 Control and Corrective Action Intervals

d...daily, w...weekly, m... monthly

Interval	Check/Activity	Target/Purpose	In Case of Deviation
d	Level, metering container	Sufficient amount/filling	Fill up; mixing chemicals, see Section 3.2.6
	Air bubbles in metering line	No air bubbles	Bleed metering pump, see Section 3.2.3
	Flow of drinking water based on the operational start-up value	Reduction of the drinking water flow up to 10 %	Fine adjustment, see Section 3.2.5 (1)
	Drinking water conductance value based on the operational start-up value	Increase of the drinking water conductance value up to 10 %	Fine adjustment, see Section 3.2.5 (2)
	Pressure difference between pump and concentrate pressure	15 % maximum above start-up difference	See Section 3.2.5 (3) Kärcher Service
	Hour meter for sand und activated carbon filter	Backwashing has occurred within the past 24 h	Kärcher Service
	Pressure difference, fine filter	≥ 0,8 bar	Replace fine filter, see Section 3.2.4
	Visual inspection of the equipment	No leakage	Kärcher Service
w	Fill out operating log		
m	Clean and flush the metering container		
	Visually check the untreated water pump	No damages/leaks detectable	Kärcher Service
	Float switch in the drinking water tank	No operational malfunctions detectable	Kärcher Service

\* for switching over the indication, see Section 3.2.2

### 3.2.2 Sand and Activated Carbon Filter

During operation, the sand and activated carbon filter control indicates the actual time. To change the indication:

- Press button (32) for approx. 5 s; the display (31) indicates the time of the regeneration.
- Press button (32) briefly; the display indicates the number of regenerations.

- Press the ADVANCE key button briefly; the display indicates the number of days and hours since the last regeneration.

- After a while the indication moves back to the current time.

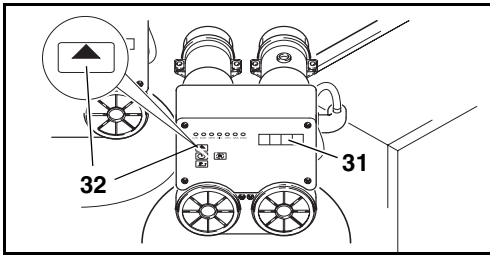

### 3.2.3 Bleeding the Metering Pump

The metering pump must be bled when the pump has drawn in air (e. g., because the metering container is completely empty).

- The system stops; the “Motor/hard water“ malfunction indication is shown in the display.



This malfunction indication is shown independent of which metering container is empty.

- Fill the empty metering container and mix the chemicals according to Section 3.2.6.

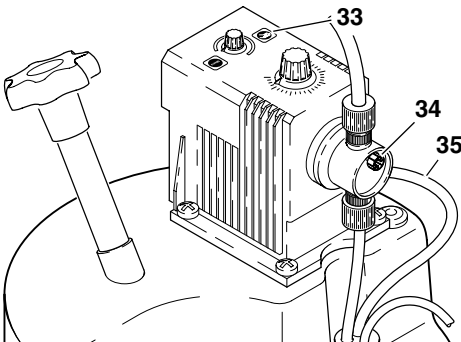

- Unscrew the bleeding screw (34) by one turn.
- Press the MANUAL pushbutton (33) until the medium flows without bubbles through the bleeding line (35) back into the container.

- Screw in the bleeding screw again.

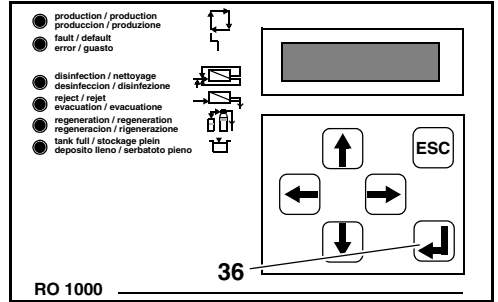

- On the control panel, acknowledge the malfunction indication with the RETURN key button (36); the system starts.

### 3.2.4 Replacing the Fine Filter

Check the pressure difference at manometers (15) and (16). Replace the filter insert when over 0.8 bar:

- Switch off the equipment at the main switch (20).
- Stop the untreated water supply.

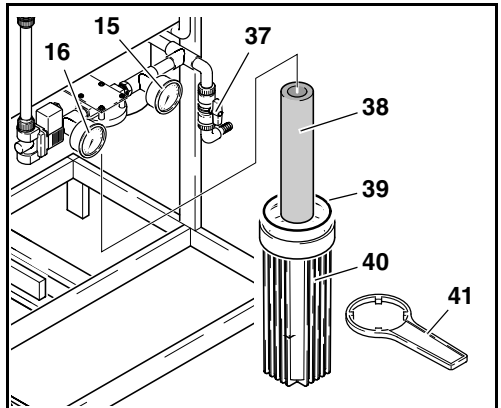

- Place a bucket under the untreated water drain cock (37) and open the cock.
- Wait until no more water emerges out of the cock, then shut the cock again.
- Attach the filter wrench (41) to the filter bowl (40) and screw off the filter bowl.



The filter bowl is still filled with water.

- Remove the filter insert (38) from the filter bowl and replace with a new one.

- Before screwing on the filter bowl, check the sealing ring (39) for damage.
- Screw on the filter bowl and tighten with the filter wrench.
- Open the untreated water supply again and start the system with the main switch.

**3.2.5 Fine Adjustment of the Operating Pressures**



In case of alterations to the system adjustments, the following values must not be exceeded under any circumstances:

- Pump pressure, max. 21 bar (MP) or 14 bar (LP)
- Drinking water amount, max. 650 l/h
- The concentrate amount must not exceed the operational start-up value



The system reacts somewhat time-delayed to alterations of the regulation valves. Therefore carry out the adjustment at the pressure control valve (14) and at the concentrate control valve (13) only in small steps, and wait until checking the respective effect.

**(1) Flow of drinking water has decreased from \_\_\_\_\_ to \_\_\_\_\_ l/h**

Read off the amount of drinking water at the flow meter (42) and compare with the value taken when starting operation (see operational start-up record).



If the flow of drinking water has decreased to \_\_\_\_\_ l/h, the following fine adjustment is to be carried out. If the fine adjustment does not lead to an increase in the drinking water flow, the Kärcher Service must be contacted.

- Slowly shut the pressure control valve (14) in clockwise direction until the desired amount is almost reached at the flow meter (42).
- Slowly shut the concentrate control valve (13) in clockwise direction until the respective set value is reached on both flow meters for concentrate (43) and drinking water (42).

Notice: The quantity of concentrate will increase. This is correct.

- Carry out a readjustment on both valve levers, if required.

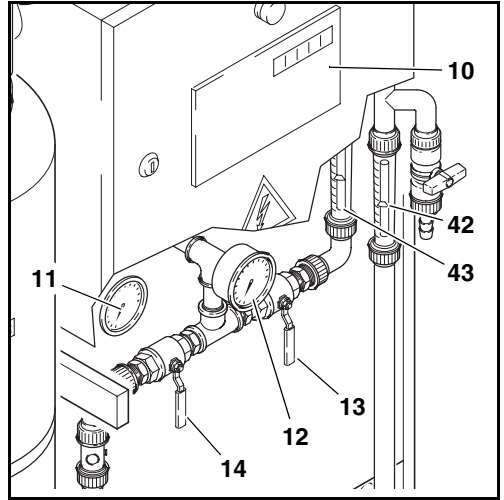

**(2) Conducting capacity of the drinking water has increased from \_\_\_\_\_ to \_\_\_\_\_ µS/cm**



Small increases of the drinking water conducting capacity do not influence the drinking water quality.

On the display of the control panel (10), read the current drinking water conductance value and compare with the value taken when starting operation (see operational start-up record).



If the drinking water conductance value has increased to \_\_\_\_\_ µS/cm, the following fine adjustment is to be carried out. If the fine adjustment does not lead to a decrease of the drinking water conductance value, the Kärcher Service must be contacted.

- Open the concentrate control valve (13) in counterclockwise direction in small steps until the conductance capacity has reached the set value.
- Shut the pressure control valve (14) in clockwise direction in small steps until the drinking water amount in the viewing glass (42) has reached the set value.



Notice: The amount of concentrate will increase. This is correct.

**Observe the maximum pressure of 21 bar (MP) or 14 bar (LP) at the manometer (11)!**

- Repeat the adjustment steps, if required. The original drinking water amount may possibly not quite be reached.

**(3) The difference between pump and concentrate pressure has increased by more than \_\_\_\_\_ bar**

- Read the values at the manometer for the pump pressure (11) and for the concentrate

pressure (12), and determine the differential pressure.

- Compare the differential pressure with the value taken when starting operation (see operational start-up record).



If the differential pressure has increased by more than \_\_\_\_\_ bar, then the RO filter membrane is clogged. Readjustment is no longer possible.

Stop the drinking water production and notify the Kärcher Service.

**3.2.6 Mixing the Chemicals**



When working with chemicals, always wear protective clothing.



Values for the metering of the various chemicals result from the untreated water analysis and the system capacity.

Upon starting operation, the Kärcher service technician enters the required metering amounts for your equipment into the following metering table.

**(1) Metering Table**

Metering Container	Chemical	Item No.	Metered Amount of the Chemical [ml] per 10 l Metering Solution
Pre-chlorination	RM 852 sterilization agent *	6.291-772.0	
	Chlorinated lime *	6.291-505.0	
Pre-flocculation	Ferrifloc	6.294-703.0	
Anti Scalant	RM 5000 hardness stabilizer	6.290-991.0	
Post chlorination	RM 852 sterilization agent *	6.291-772.0	
	Chlorinated lime *	6.291-505.0	

\* These chemicals can each be used alternatively

**(2) Metered Addition**

For mixing of the chemical, only **un-chlorinated** drinking water may be used.

This water is taken from the drinking water sampling valve (44).

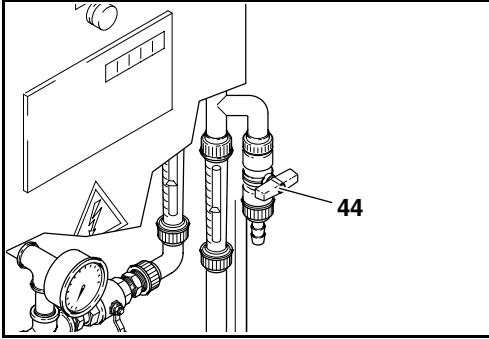

The metered addition is carried out dependent of the level in the metering container.

**Completely emptied metering container:**

- Fill 10 l of drinking water into the metering container.
- With a measuring cup, measure the 7.5 -fold amount mentioned in the "10 Liter Water" column of the respective chemical and fill into the container.
- Fill the container with drinking water to the "75 l" mark and mix according to Section 3.1.2.

**Partially emptied metering container:**

- Read off the level of the fluid with help of the scale at the metering container, e. g., 35 l.
- Determine the quantity to be refilled by subtracting the read level from the 75 l.  
Example:  $75 \text{ l} - 35 \text{ l} = 40 \text{ l}$ .
- Determine the required amount of the respective chemical from the metering table.  
Example:  $4 \times$  the amount for 10 l water.
- Measure the determined amount of the respective chemical and fill into the container.
- Refill amount of water to the "75 l" mark and mix in accordance with Section 3.1.2.

**3.3 Switching Off the Equipment**

If the equipment is not operated for periods exceeding 14 days, it must be preserved by the Kärcher Service. Otherwise permanent damage must be expected.

- Switch the main switch (20) to the "O" position; the equipment stops the drinking water production.



Never switch off the equipment overnight! Otherwise the automatic cleaning of the pre-filter is not carried through. Danger of damage to the equipment is given!

**4 Consumption Materials**

Product	Item No.
RM 852 sterilization agent 24 kg	6.291-772.0
Chlorinated lime 6 x 870 g	6.291-505.0
RM 5000 hardness stabilizer 23 kg	6.290-991.0
RM 5001 flocculation agent 10 l	6.294-703.0
RM 5001 flocculation agent 60 l	6.294-716.0
Filter element 5µ	6.414-466.0

## 5 Malfunctions

Malfunctions of the **RO system** are signaled with LEDs at the control panel (10) and indicated at the display.



In case of a malfunction, the system is generally switched off and the drinking water production is interrupted.

If the malfunction can not be corrected, stop the drinking water production and notify the Kärcher Service.

	Designation/Indication	Possible Cause	Corrective Action
LED	fault	Metering container empty Sensor signal missing	Fill metering container and acknowledge malfunction afterwards Kärcher Service
	regeneration	Flushing of the pre-filter is active	Not required, as the system switches on again automatically
	tank full	Drinking water tank full Switch defective	Not required, as the system switches on again automatically Check switch; if required, Kärcher Service
Display	CV exceeded	Conductance value of the drinking water too high	Kärcher Service
	Hard water	Metering container empty	Fill metering container and acknowledge malfunction afterwards
	Pressure malfunction	Pressure of untreated water too low	Check untreated water supply <ul style="list-style-type: none"> <li>• Installation on building side</li> <li>• Admission-pressure pump</li> <li>• Hoses for untreated water</li> </ul>

Malfunctions on the **admission-pressure unit** are indicated with the red LED (26) on the control unit of the admission-pressure unit.

Indication	Possible Cause	Corrective Action
Red LED lights	Untreated water supply disconnected	Check and reestablish the untreated water supply. After correcting the malfunction, press the "Reset" pushbutton (23).

## 6 Technical Data

Parameter	WTC 600 LP	WTC 600 MP
Ambient temperature	+1 °C – +50 °C	
Storage temperature (upon delivery)	to –10 °C	
Humidity	<100% r.F.	
Supply voltage	3*400 V 50 Hz * 1*230 V 50 Hz *	
Pre-filter controls: prim./sec.	230 V/12 V 50 Hz	
Metering pumps	220 – 240 V 50 – 60Hz	
Electrical protection	16 A	
Connected load	2.2kW	2.2 kW
Effective power consumption	1.5 kW	2.2 kW
Minimum temperature of untreated water	+5 °C	
Maximum temperature of untreated water	+35 °C	
Reference temperature	+15 °C	
pH-value of untreated water	6 – 9.5	
pH-value cleaning agent for cleaning the equipment	3 – 11	
System intake pressure	2 – 6 bar	
Capacity range	15000 l/day (±15 %)	
Maximum drinking water supply	650 l/h	
Dimensions: H x W x D		
WTC 600 LP/MP	1800 x 660 x 720 mm	
WTC 600 LP/MP - A	1800 x 1120 x 720 mm	
WTC 600 LP/MP - AM	1800 x 1120 x 720 mm	
Weight, in delivery condition		
WTC 600 LP/MP	135 kg	
WTC 600 LP/MP - A	155 kg	
WTC 600 LP/MP - AM	175 kg	
Designed for untreated water based on a maximum salt content of	2000 ppm	5000 ppm

\* depending on supply by the customer

## 7 EU Declaration of Conformity

We hereby declare that the equipment described below conforms to the relevant fundamental safety and health requirements of the appropriate EU Directive, both in its basic design and construction as well as in the version marketed by us.

This declaration will cease to be valid if any modifications are made to the machine without our express approval.

Product: **Water treatment plant**

Model: **1.024-xxx**

Relevant EU Directives: **EU - Machinery Directive (98/37/EU)**  
**EU - Low-Voltage Equipment Directive (73/23/EEC) amended by 93/68/EEC**  
**EU - Directive on Electromagnetic Compatibility (89/336/EEC) amended by 91/263/EEC, 92/31/EEC, 93/68/EEC**

Harmonized standards applied: **DIN EN ISO 14971**  
**DIN EN 50178**  
**DIN EN 60 204 – 1**  
**DIN EN 55 011 : 1998**  
**DIN EN 55 014 – 1 : 2000 + A1: 2001 + A2 : 2002**  
**DIN EN 55 014 – 2 : 1997 + A1: 2001**  
**DIN EN 61 000 – 3 – 2 : 2000**  
**DIN EN 61 000 – 3 – 3 : 1995 + A1: 2001**

National standards applied: **DIN 1988**

Winnenden



S. Reiser



H. Jenner

Appropriate internal measures have been taken to ensure that series-production units conform at all times to the requirements of current EU Directives and relevant standards.

The signatories are empowered to represent and act on behalf of the company management.

Alfred Kärcher Kommanditgesellschaft, Sitz Winnenden. Registergericht: Waiblingen, HRA 169.

Persönlich haftende Gesellschafterin: Kärcher Reinigungstechnik GmbH, Sitz Winnenden, 2404 Registergericht Waiblingen, HRB

Geschäftsführer: Dr. Bernhard Graf, Hartmut Jenner, Georg Metz

5.957-716  
06/05

## Free Manuals Download Website

<http://myh66.com>

<http://usermanuals.us>

<http://www.somanuals.com>

<http://www.4manuals.cc>

<http://www.manual-lib.com>

<http://www.404manual.com>

<http://www.luxmanual.com>

<http://aubethermostatmanual.com>

Golf course search by state

<http://golfingnear.com>

Email search by domain

<http://emailbydomain.com>

Auto manuals search

<http://auto.somanuals.com>

TV manuals search

<http://tv.somanuals.com>