

**REACH-INS
REFRIGERATORS**

KCBM180R

KCBM23R

KCBM48R

KCBM72R

FREEZERS

KCBM180F

KCBM23F

KCBM48F

KCBM72F

**FOOD PREP
TABLES**

SANDWICH

KCST27.8

KCST48.12

KCST60.16

KCST70.16

KCST70.18

MEGA

KCMT27.12

KCMT48.18

KCMT60.24

KCMT70.27

KCMT70.30

PIZZA

KCPT50.6

KCPT72.9

KCPT92.12

**UNDER COUNTERS
REFRIGERATORS**

KCUC27R

KCUC48R

FREEZERS

KCUC27F

KCUC48F

**GLASS DOOR
MERCHANTISERS**

REFRIGERATORS

KCGM10R

KCGM180R

KCGM24R

KCGM47R

FREEZERS

KCGM9F

KCGM24F

KCGM27F

BAR EQUIPMENT

SOLID DOOR

KCBB48S

KCBB60S

KCBB72S

GLASS DOOR

KCBB48G

KCBB60G

KCBB72G

BOTTLE COOLERS

KCBC50

KCBC65

MILK COOLERS

KCMC34R

KCMC49R

KCMC58R

CHEST FREEZERS

SOLID TOP

KCCF070Q

KCCF160Q

KCCF180Q

KCCF220Q

NOVELTY FREEZER

KCNF070Q

KCNF160Q

KCNF180Q

**DISCONTINUED
MODELS**

KRS220R

KFS220R

KGM220R

KCS070G

KCS150L

KCS200G

KCG070G

KCG150L

KCG200G

Kelvinator ®



REACH-INS



Dynamic Condenser improves performance in high temperature environments

Automatic Defrost Cooling System provides worry-free performance

1/4 HP Compressor

Mechanical Control

Internal Temperature Display

Adjustable Shelves

Spring-Assisted Hinge with 90-degree stay-open feature

Lock & Key protects the contents of the unit

Heavy Duty Casters

Reversible Door

Interior Lighting



Vinyl Heavy Duty Adjustable Shelves

Shelves that are easy to handle and keep clean.



NSF®-Certified Temperature

Durable and reliable for safety in food storage.



Heavy-Duty, Locking Casters

Keeps unit in place but allows position adjusting.

TECHNICAL SPECIFICATIONS

MODEL	KCBM180RQY
Product Line	Refrigerator
Capacity (Cu. Ft.)	17.89
Condenser Type	Dynamic
Automatic Defrost Cooling System	Yes
Compressor Horsepower	1/4
Exterior Finish	Textured Painted Steel
Interior Finish	Smooth Painted Steel
Shelves (Number/Type)	4/Vinyl-Coated Steel
Control	Mechanical
Temperature Display Location	Internal
Temperature Range	32 to 44°F
Voltage Rating	115V/5A
Run Amps	1.3
Plug Type	NEMA 5-15P
Shipping Weight (Lbs.)	275
Warranty	3 Year/5 Year



18 CU. FT. REACH-IN REFRIGERATOR

KCBM180RQY

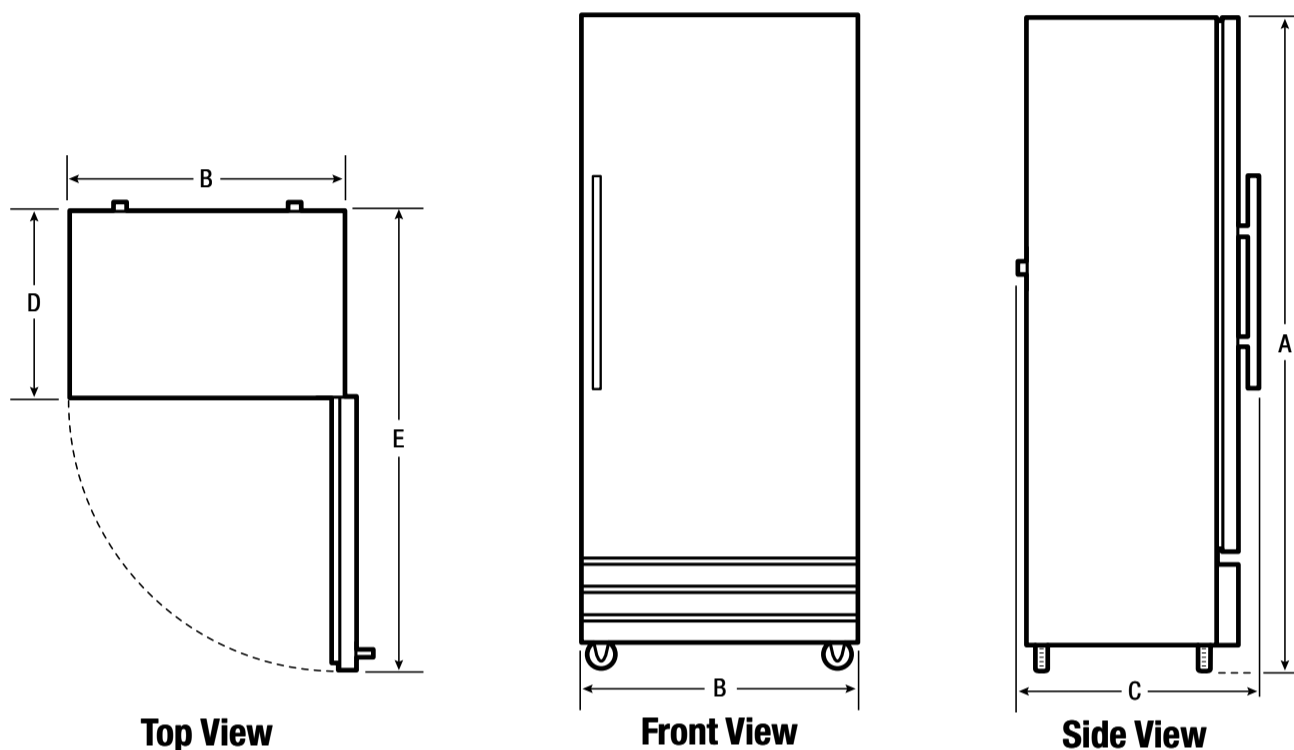

Plug Type (NEMA)
5-15P

EXTERIOR DIMENSIONS

Height A (Including Casters)	75"
Width B	32"
Overall Depth (Including Door & Handle) C	30-1/2"
Cabinet Depth D	26-1/2"
Depth (with Door 90° Open) E	57"

CERTIFICATIONS AND APPROVALS

ENERGY STAR® Qualified	Yes
Safety Certification	CSA
Sanitation Certification	NSF®

ACCESSORIES

Deep shelf (<i>Fits all except top position, white finish</i>)	216384002
Shallow top shelf (<i>Only fits top position, white finish</i>)	216386202
Trivet, white finish	216331802
Shelf support clips (<i>Sold as singles, requires 4 per shelf</i>)	297121900
Pan slide kit (<i>Includes 2 racks/4 clips, holds 8 pans 18" x 26"</i>)	PANRACKKIT
Casters, Front	297206600
Casters, Back	297206500
Caster hardware kit	297256300
Key for lock	216362800
Upright locks	216362700



USA • 10200 David Taylor Drive • Charlotte, NC 28262 • 1-866-738-1640 • kelvinator.com
CANADA • 5855 Terry Fox Way • Mississauga, ON L5V 3E4

KCBM180RQ 06/15

© 2015 Electrolux Home Products, Inc.

High standards of quality at Electrolux Home Products, Inc. mean we are constantly working to improve our products. We reserve the right to change specifications or discontinue models without notice.



Dynamic Condenser improves performance in high temperature environments

Automatic Defrost Cooling System provides worry-free performance

1/3 HP Compressor

Stainless Steel Exterior & Interior

Electronic Control

External Temperature Display

Removable Door Gasket

Adjustable Shelves

Self-Closing Door with 90-degree stay-open feature

Lock & Key protects the contents of the unit

Heavy Duty Casters

Reversible Door

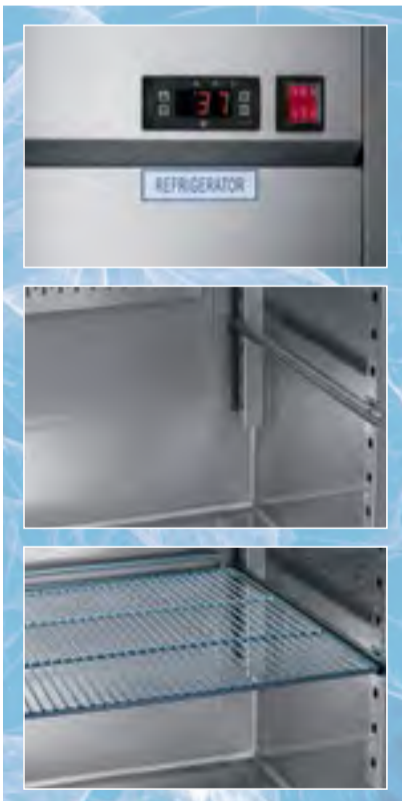

Electronic Digital Temperature Control

Quick set digital control and display for easy monitoring.

Stainless Steel Interior

Durable and easy to clean for daily commercial use.

Vinyl Heavy Duty Adjustable Shelves

Shelves that are easy to handle and keep clean.

TECHNICAL SPECIFICATIONS

MODEL	KCBM23R
Product Line	Refrigerator
Capacity (Cu. Ft.)	23.0
Condenser Type	Dynamic
Automatic Defrost Cooling System	Yes
Compressor Horsepower	1/3
Exterior Finish	Stainless Steel (430)
Interior Finish	Stainless Steel (304)
Shelves (Number/Type)	3/Vinyl-Coated Steel
Control	Electronic
Temperature Display Location	External
Temperature Range	32 to 50°F
Voltage Rating	115V/60Hz
Run Amps	7.4
Plug Type	NEMA 5-15P
Shipping Weight (Lbs.)	350
Warranty	3 Year/5 Year



23 CU. FT. REACH-IN REFRIGERATOR

KCBM23R

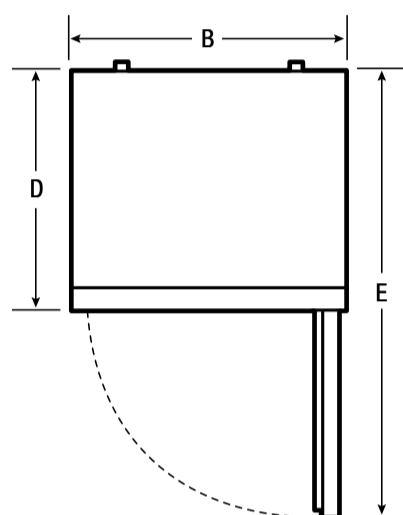

Top View

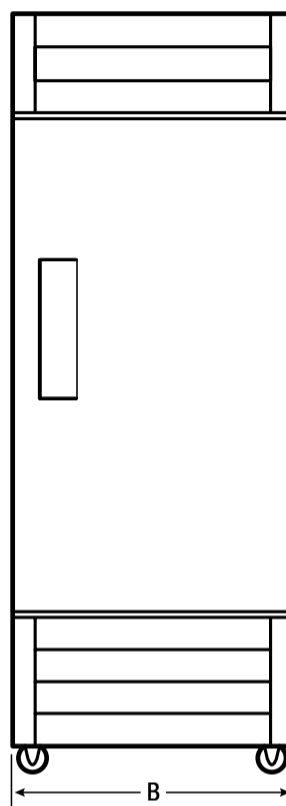

Front View

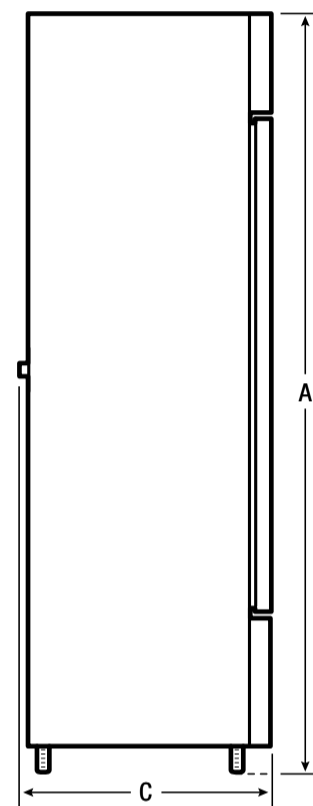

Side View



Plug Type (NEMA)
5-15P

EXTERIOR DIMENSIONS

Height A (Including Casters)	82"
Width B	29"
Overall Depth (Including Door & Handle) C	34"
Cabinet Depth D	32"
Depth (with Door 90° Open) E	58-1/2"

CERTIFICATIONS AND APPROVALS

ENERGY STAR® Qualified	Yes
Safety Certification	ETL
Sanitation Certification	ETL

ACCESSORIES

Shelf	5304492224
Shelf Rail	5304492223
Door Lock	5304492260
Key	5304492341



USA • 10200 David Taylor Drive • Charlotte, NC 28262 • 1-866-738-1640 • kelvinator.com
CANADA • 5855 Terry Fox Way • Mississauga, ON L5V 3E4

KCBM23R 06/15

© 2015 Electrolux Home Products, Inc.

High standards of quality at Electrolux Home Products, Inc. mean we are constantly working to improve our products. We reserve the right to change specifications or discontinue models without notice.



48 CU. FT. REACH-IN REFRIGERATOR

KCBM48R



Dynamic Condenser improves performance in high temperature environments

Automatic Defrost Cooling System provides worry-free performance

1/2 HP Compressor

Stainless Steel Exterior & Interior

Electronic Control

External Temperature Display

Removable Door Gaskets

Adjustable Shelves

Self-Closing Doors with 90-degree stay-open feature

Lock & Key protects the contents of the unit

Heavy Duty Casters



Electronic Digital Temperature Control

Quick set digital control and display for easy monitoring.

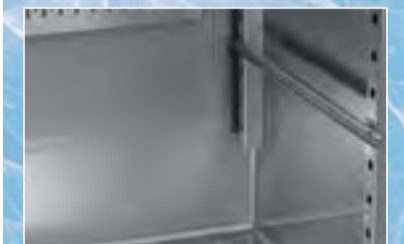

Stainless Steel Interior

Durable and easy to clean for daily commercial use.



Vinyl Heavy Duty Adjustable Shelves

Shelves that are easy to handle and keep clean.

TECHNICAL SPECIFICATIONS

MODEL	KCBM48R
Product Line	Refrigerator
Capacity (Cu. Ft.)	48.0
Condenser Type	Dynamic
Automatic Defrost Cooling System	Yes
Compressor Horsepower	1/2
Exterior Finish	Stainless Steel (430)
Interior Finish	Stainless Steel (304)
Shelves (Number/Type)	6/Vinyl-Coated Steel
Control	Electronic
Temperature Display Location	External
Temperature Range	32 to 50°F
Voltage Rating	115V/60Hz
Run Amps	9.4
Plug Type	NEMA 5-15P
Shipping Weight (Lbs.)	542
Warranty	3 Year/5 Year



48 CU. FT. REACH-IN REFRIGERATOR

KCBM48R

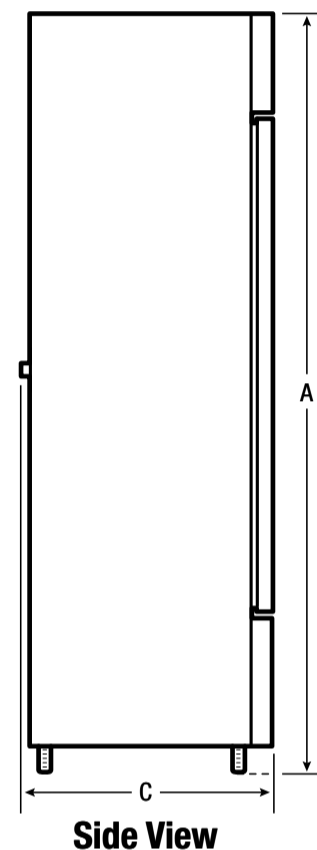
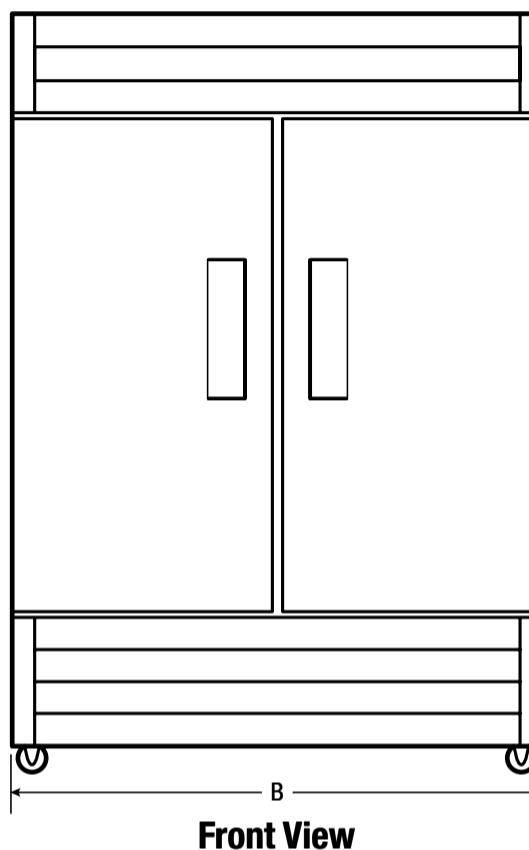
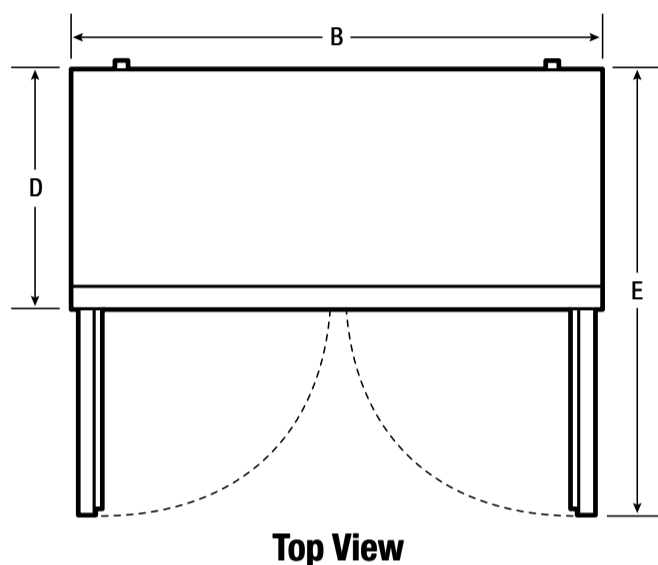

Plug Type (NEMA)
5-15P

EXTERIOR DIMENSIONS

Height A (Including Casters)	82"
Width B	54"
Overall Depth (Including Door & Handle) C	34"
Cabinet Depth D	32"
Depth (with Door 90° Open) E	57"

CERTIFICATIONS AND APPROVALS

ENERGY STAR® Qualified	Yes
Safety Certification	ETL
Sanitation Certification	ETL

ACCESSORIES

Shelf	5304492224
Shelf Rail	5304492223
Door Lock	5304492260
Key	5304492341



USA • 10200 David Taylor Drive • Charlotte, NC 28262 • 1-866-738-1640 • kelvinator.com
CANADA • 5855 Terry Fox Way • Mississauga, ON L5V 3E4

KCBM48R 06/15

© 2015 Electrolux Home Products, Inc.

High standards of quality at Electrolux Home Products, Inc. mean we are constantly working to improve our products. We reserve the right to change specifications or discontinue models without notice.



72 CU. FT. REACH-IN REFRIGERATOR

KCBM72R



Fin & Tube Condenser improves performance in high temperature environments

Automatic Defrost Cooling System provides worry-free performance

1 HP Compressor

Stainless Steel Exterior & Interior

Electronic Control

External Temperature Display

Removable Door Gaskets

Adjustable Shelves

Self-Closing Doors with 90-degree stay-open feature

Lock & Key protects the contents of the unit

Heavy Duty Casters



Electronic Digital Temperature Control

Quick set digital control and display for easy monitoring.

Stainless Steel Interior

Durable and easy to clean for daily commercial use.

Heavy Duty Adjustable Shelves

Shelves that are easy to handle and keep clean.

TECHNICAL SPECIFICATIONS

MODEL	KCBM72R
Product Line	Refrigerator
Capacity (Cu. Ft.)	72.0
Condenser Type	Fin & Tube
Automatic Defrost Cooling System	Yes
Compressor Horsepower	1
Exterior Finish	Stainless Steel (430)
Interior Finish	Stainless Steel (304)
Shelves (Number/Type)	9/Coated Steel
Control	Electronic
Temperature Display Location	External
Temperature Range	32 to 50°F
Voltage Rating	115V/60Hz
Run Amps	10.5
Plug Type	NEMA 5-20P
Shipping Weight (Lbs.)	659
Warranty	3 Year/5 Year



72 CU. FT. REACH-IN REFRIGERATOR

KCBM72R

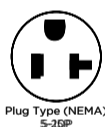
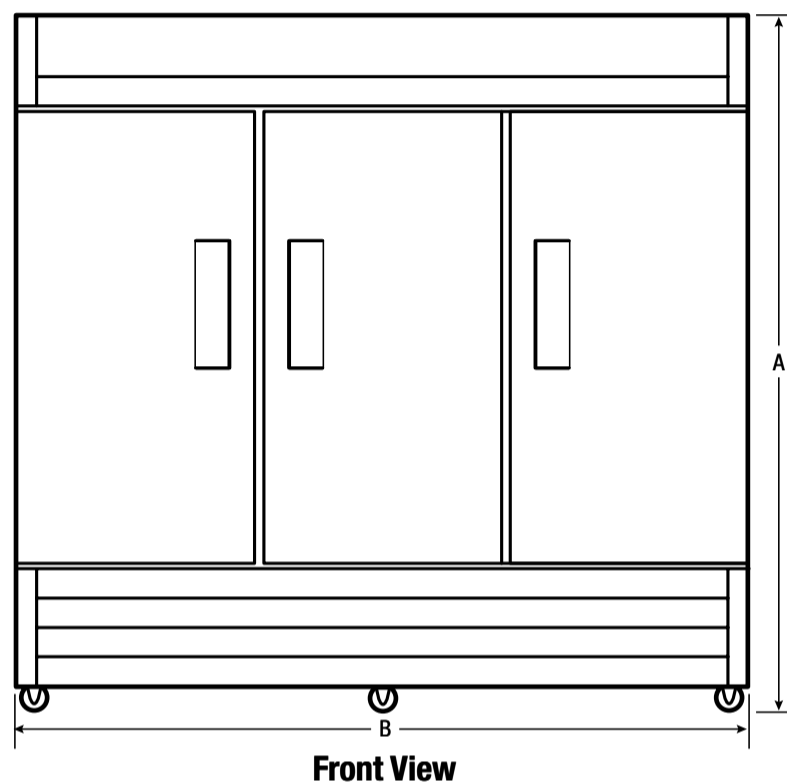
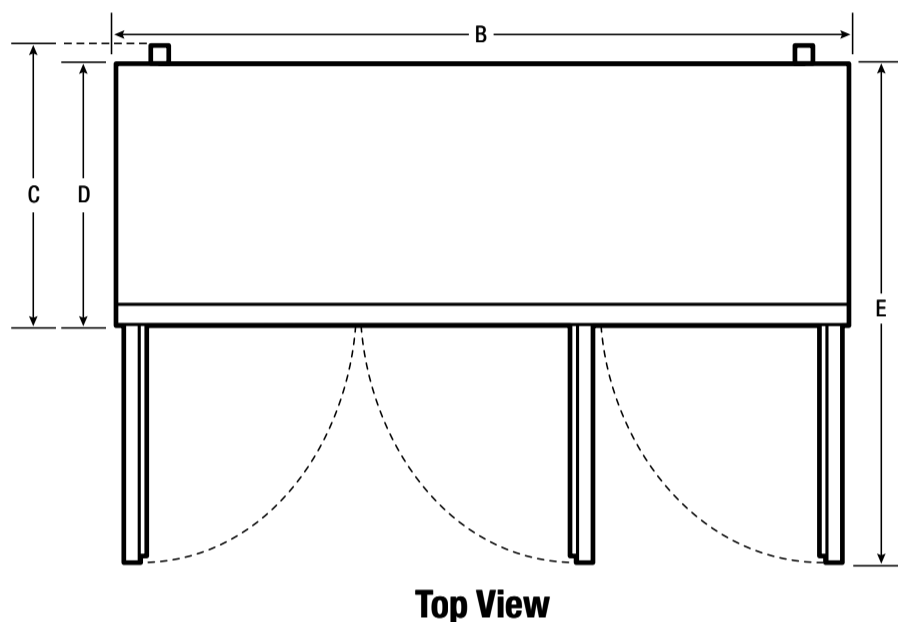

EXTERIOR DIMENSIONS

Height A (Including Casters)	82"
Width B	81"
Overall Depth (Including Door & Handle) C	34"
Cabinet Depth D	32"
Depth (with Door 90° Open) E	57-1/4"

CERTIFICATIONS AND APPROVALS

Safety Certification	ETL
Sanitation Certification	ETL

ACCESSORIES

Shelf	5304492224
Shelf Rail	5304492223
Door Lock	5304492260
Key	5304492341



USA • 10200 David Taylor Drive • Charlotte, NC 28262 • 1-866-738-1640 • kelvinator.com

CANADA • 5855 Terry Fox Way • Mississauga, ON L5V 3E4

KCBM72R 06/15

© 2015 Electrolux Home Products, Inc.

High standards of quality at Electrolux Home Products, Inc. mean we are constantly working to improve our products. We reserve the right to change specifications or discontinue models without notice.



18 CU. FT. REACH-IN FREEZER

KCBM180FQY



Dynamic Condenser improves performance in high temperature environments

Automatic Defrost Cooling System provides worry-free performance

1/2 HP Compressor

Mechanical Control

Internal Temperature Display

Adjustable Shelves

Spring-Assisted Hinge with 90-degree stay-open feature

Lock & Key protects the contents of the unit

Heavy Duty Casters

Reversible Door

Interior Lighting



Vinyl Heavy Duty Adjustable Shelves

Shelves that are easy to handle and keep clean.



NSF®-Certified Temperature

Durable and reliable for safety in food storage.



Heavy-Duty, Locking Casters

Keeps unit in place but allows position adjusting.

TECHNICAL SPECIFICATIONS

MODEL	KCBM180FQY
Product Line	Freezer
Capacity (Cu. Ft.)	18
Condenser Type	Dynamic
Automatic Defrost Cooling System	Yes
Compressor Horsepower	1/2
Exterior Finish	Textured Painted Steel
Interior Finish	Smooth Painted Steel
Shelves (Number/Type)	4/Vinyl-Coated Steel
Control	Mechanical
Temperature Display Location	Internal
Temperature Range	-10 to 10°F
Voltage Rating	115V/5A
Run Amps	2.3
Plug Type	NEMA 5-15P
Shipping Weight (Lbs.)	275
Warranty	3 Year/5 Year



18 CU. FT. REACH-IN FREEZER

KCBM180FQY

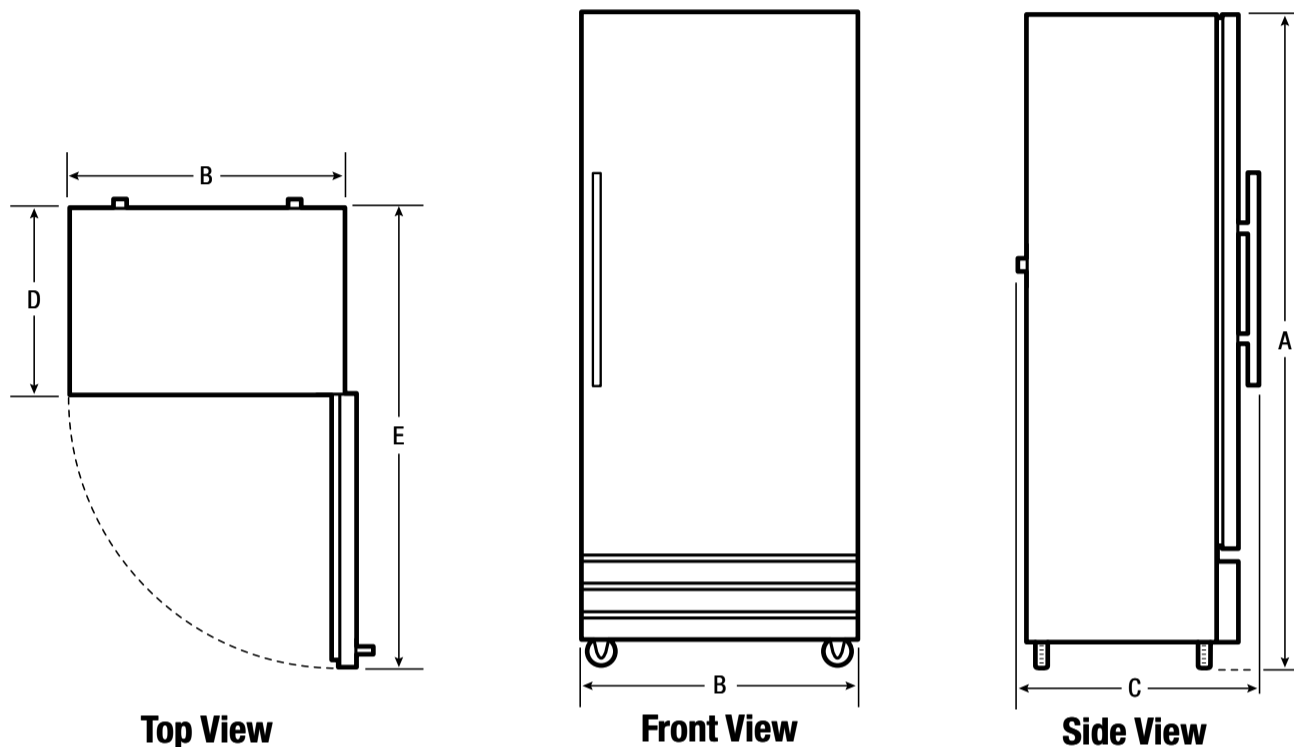

Plug Type (NEMA)
5-15P

EXTERIOR DIMENSIONS

Height A (Including Casters)	75"
Width B	32"
Overall Depth (Including Door & Handle) C	30-1/2"
Cabinet Depth D	26-1/2"
Depth (with Door 90° Open) E	57"

CERTIFICATIONS AND APPROVALS

ENERGY STAR® Qualified	Yes
Safety Certification	CSA
Sanitation Certification	NSF®

ACCESSORIES

Deep shelf (<i>Fits all except top position, white finish</i>)	216384002
Shallow top shelf (<i>Only fits top position, white finish</i>)	216386202
Trivet, white finish	216331802
Shelf support clips (<i>Sold as singles, requires 4 per shelf</i>)	297121900
Pan slide kit (<i>Includes 2 racks/4 clips, holds 8 pans 18" x 26"</i>)	PANRACKKIT
Casters, Front	297206600
Casters, Back	297206500
Caster hardware kit	297256300
Key for lock	216362800
Upright locks	216362700



USA • 10200 David Taylor Drive • Charlotte, NC 28262 • 1-866-738-1640 • kelvinator.com
CANADA • 5855 Terry Fox Way • Mississauga, ON L5V 3E4

KCBM180FQ 06/15

© 2015 Electrolux Home Products, Inc.

High standards of quality at Electrolux Home Products, Inc. mean we are constantly working to improve our products. We reserve the right to change specifications or discontinue models without notice.



23 CU. FT. REACH-IN FREEZER

KCBM23F



Dynamic Condenser improves performance in high temperature environments

Automatic Defrost Cooling System provides worry-free performance

3/4 HP Compressor

Stainless Steel Exterior & Interior

Electronic Control

External Temperature Display

Removable Door Gasket

Adjustable Shelves

Self-Closing Door with 90-degree stay-open feature

Lock & Key protects the contents of the unit

Heavy Duty Casters

Reversible Door



Electronic Digital Temperature Control

Quick set digital control and display for easy monitoring.

Stainless Steel Interior

Durable and easy to clean for daily commercial use.

Vinyl Heavy Duty Adjustable Shelves

Shelves that are easy to handle and keep clean.

TECHNICAL SPECIFICATIONS

MODEL	KCBM23F
Product Line	Freezer
Capacity (Cu. Ft.)	23.0
Condenser Type	Dynamic
Automatic Defrost Cooling System	Yes
Compressor Horsepower	3/4
Exterior Finish	Stainless Steel (430)
Interior Finish	Stainless Steel (304)
Shelves (Number/Type)	3/Vinyl-Coated Steel
Control	Electronic
Temperature Display Location	External
Temperature Range	-7 to 10°F
Voltage Rating	115V/60Hz
Run Amps	8.3
Plug Type	NEMA 5-15P
Shipping Weight (Lbs.)	358
Warranty	3 Year/5 Year



23 CU. FT. REACH-IN FREEZER

KCBM23F

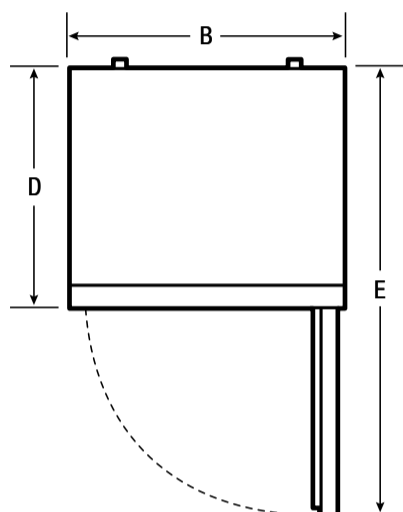

Top View

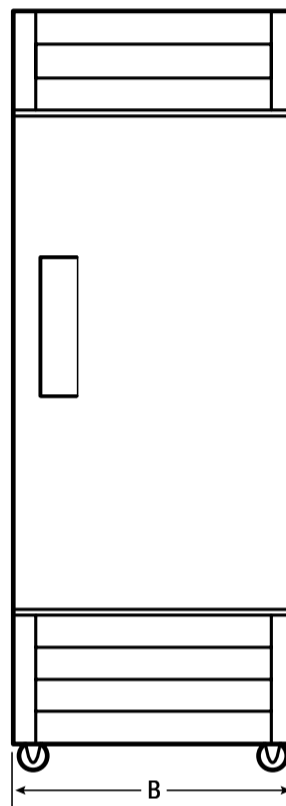

Front View

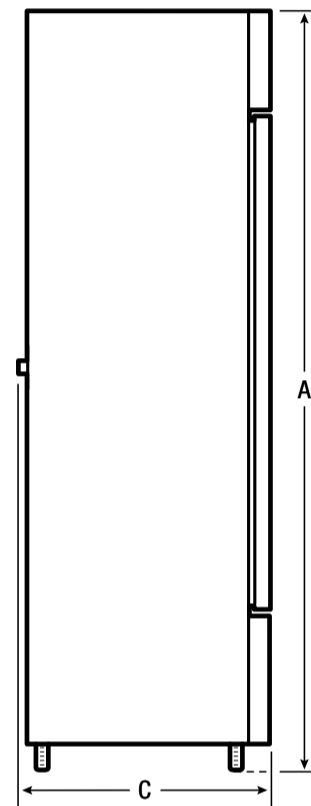

Side View



Plug Type (NEMA)
5-15P

EXTERIOR DIMENSIONS

Height A (Including Casters)	82"
Width B	29"
Overall Depth (Including Door & Handle) C	34"
Cabinet Depth D	32"
Depth (with Door 90° Open) E	58-1/2"

CERTIFICATIONS AND APPROVALS

ENERGY STAR® Qualified	Yes
Safety Certification	ETL
Sanitation Certification	ETL

ACCESSORIES

Shelf	5304492224
Shelf Rail	5304492223
Door Lock	5304492260
Key	5304492341



USA • 10200 David Taylor Drive • Charlotte, NC 28262 • 1-866-738-1640 • kelvinator.com
CANADA • 5855 Terry Fox Way • Mississauga, ON L5V 3E4

KCBM23F 06/15

© 2015 Electrolux Home Products, Inc.

High standards of quality at Electrolux Home Products, Inc. mean we are constantly working to improve our products. We reserve the right to change specifications or discontinue models without notice.



48 CU. FT. REACH-IN FREEZER

KCBM48F



Dynamic Condenser improves performance in high temperature environments

Automatic Defrost Cooling System provides worry-free performance

1 HP Compressor

Stainless Steel Exterior & Interior

Electronic Control

External Temperature Display

Removable Door Gaskets

Adjustable Shelves

Self-Closing Doors with 90-degree stay-open feature

Lock & Key protects the contents of the unit

Heavy Duty Casters



Electronic Digital Temperature Control

Quick set digital control and display for easy monitoring.

Stainless Steel Interior

Durable and easy to clean for daily commercial use.

Vinyl Heavy Duty Adjustable Shelves

Shelves that are easy to handle and keep clean.

TECHNICAL SPECIFICATIONS

MODEL	KCBM48F
Product Line	Freezer
Capacity (Cu. Ft.)	48.0
Condenser Type	Dynamic
Automatic Defrost Cooling System	Yes
Compressor Horsepower	1
Exterior Finish	Stainless Steel (430)
Interior Finish	Stainless Steel (304)
Shelves (Number/Type)	6/Vinyl-Coated Steel
Control	Electronic
Temperature Display Location	External
Temperature Range	-7 to 10°F
Voltage Rating	115V/60Hz
Run Amps	10.5
Plug Type	NEMA 5-20P
Shipping Weight (Lbs.)	559
Warranty	3 Year/5 Year

kelvinator.com



48 CU. FT. REACH-IN FREEZER

KCBM48F

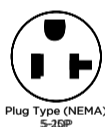
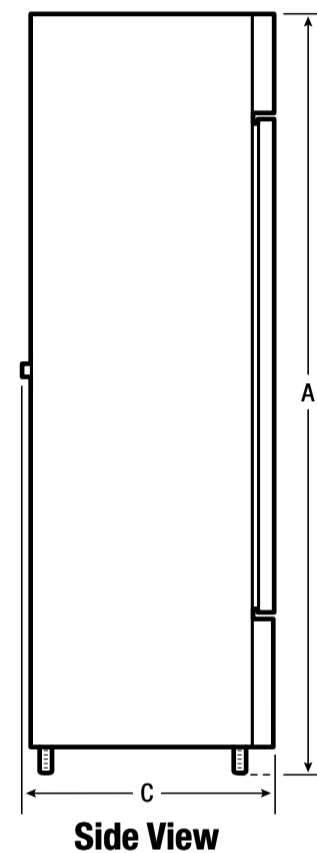
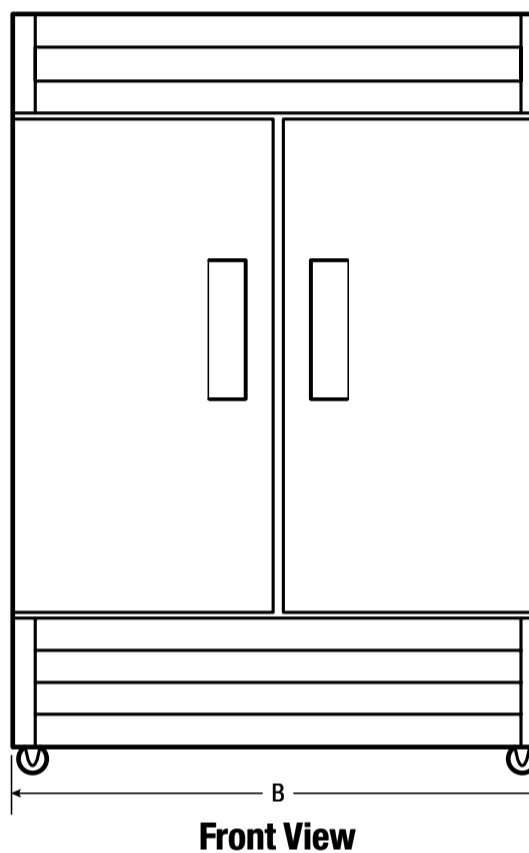
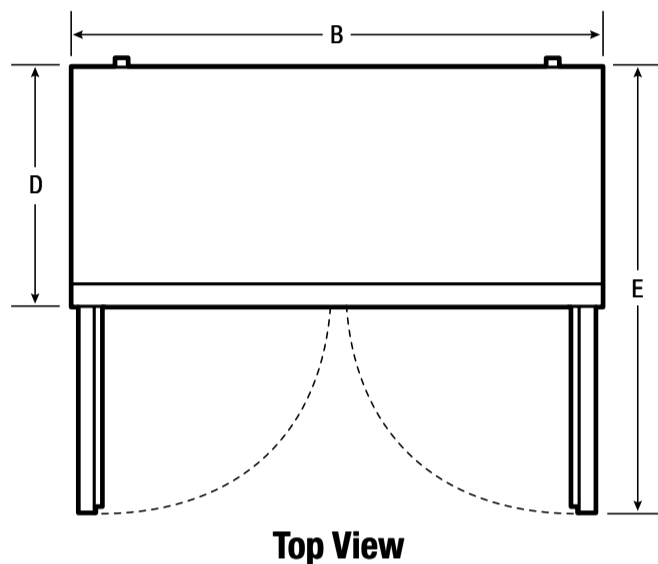

EXTERIOR DIMENSIONS

Height A (Including Casters)	82"
Width B	54"
Overall Depth (Including Door & Handle) C	34"
Cabinet Depth D	32"
Depth (with Door 90° Open) E	57"

CERTIFICATIONS AND APPROVALS

ENERGY STAR® Qualified	Yes
Safety Certification	ETL
Sanitation Certification	ETL

ACCESSORIES

Shelf	5304492224
Shelf Rail	5304492223
Door Lock	5304492260
Key	5304492341



USA • 10200 David Taylor Drive • Charlotte, NC 28262 • 1-866-738-1640 • kelvinator.com
 CANADA • 5855 Terry Fox Way • Mississauga, ON L5V 3E4

KCBM48F 06/15

© 2015 Electrolux Home Products, Inc.

High standards of quality at Electrolux Home Products, Inc. mean we are constantly working to improve our products. We reserve the right to change specifications or discontinue models without notice.



72 CU. FT. REACH-IN FREEZER

KCBM72F



Fin & Tube Condenser improves performance in high temperature environments

Automatic Defrost Cooling System provides worry-free performance

1 HP Compressor

Stainless Steel Exterior & Interior

Electronic Control

External Temperature Display

Removable Door Gaskets

Adjustable Shelves

Self-Closing Doors with 90-degree stay-open feature

Lock & Key protects the contents of the unit

Heavy Duty Casters



Electronic Digital Temperature Control

Quick set digital control and display for easy monitoring.

Stainless Steel Interior

Durable and easy to clean for daily commercial use.

Heavy Duty Adjustable Shelves

Shelves that are easy to handle and keep clean.

TECHNICAL SPECIFICATIONS

MODEL	KCBM72F
Product Line	Freezer
Capacity (Cu. Ft.)	72.0
Condenser Type	Fin & Tube
Automatic Defrost Cooling System	Yes
Compressor Horsepower	1
Exterior Finish	Stainless Steel (430)
Interior Finish	Stainless Steel (304)
Shelves (Number/Type)	9/Coated Steel
Control	Electronic
Temperature Display Location	External
Temperature Range	-7 to 10°F
Voltage Rating	115V/60Hz
Run Amps	10.5
Plug Type	NEMA 5-20P
Shipping Weight (Lbs.)	659
Warranty	3 Year/5 Year

kelvinator.com



72 CU. FT. REACH-IN FREEZER

KCBM72F

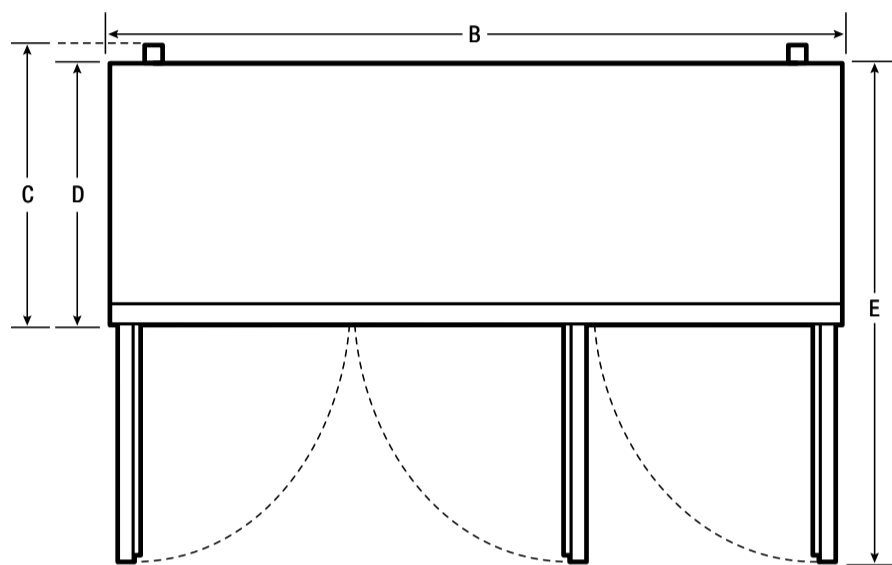

Top View

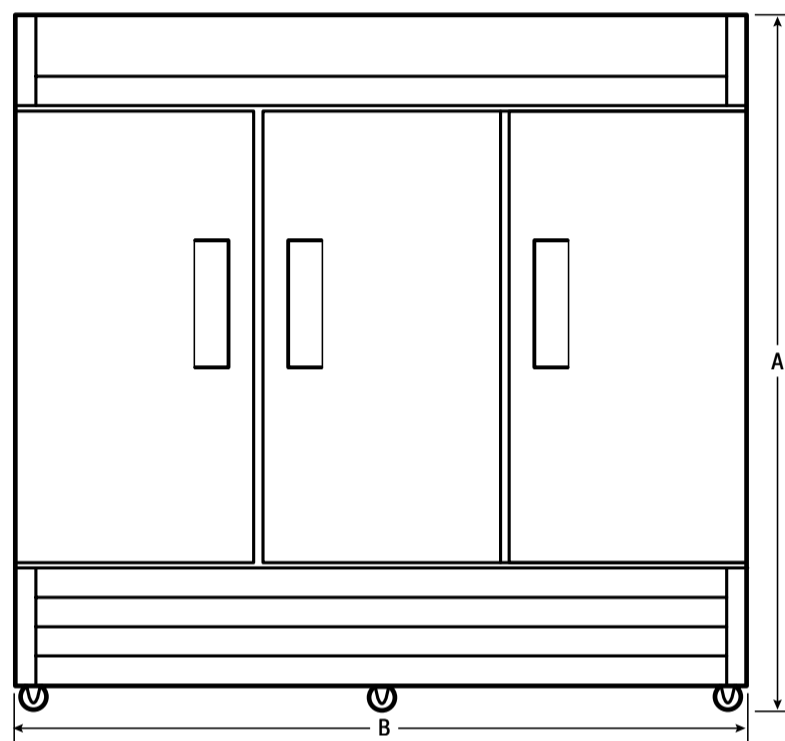

Front View

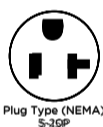

Plug Type (NEMA)
5-20P

EXTERIOR DIMENSIONS

Height A (Including Casters)	82"
Width B	81"
Overall Depth (Including Door & Handle) C	34"
Cabinet Depth D	32"
Depth (with Door 90° Open) E	57-1/2"

CERTIFICATIONS AND APPROVALS

Safety Certification	ETL
Sanitation Certification	ETL

ACCESSORIES

Shelf	5304492224
Shelf Rail	5304492223
Door Lock	5304492260
Key	5304492341



USA • 10200 David Taylor Drive • Charlotte, NC 28262 • 1-866-738-1640 • kelvinator.com
CANADA • 5855 Terry Fox Way • Mississauga, ON L5V 3E4

KCBM72F 06/15

© 2015 Electrolux Home Products, Inc.

High standards of quality at Electrolux Home Products, Inc. mean we are constantly working to improve our products. We reserve the right to change specifications or discontinue models without notice.

Kelvinator 



FOOD PREP
TABLES



6 CU. FT. SANDWICH / SALAD PREP TABLE

KCST27.8



Dynamic Condenser improves performance in high temperature environments

Automatic Defrost Cooling System provides worry-free performance

1/5 HP Compressor

Stainless Steel Exterior & Interior

Electronic Control

Removable Door Gasket

Holds 1/6 & 1/9 Pans

Adjustable Shelves Vinyl-Coated Steel

Self-Closing Door with 90-degree stay-open feature

Heavy Duty Casters



Electronic Digital Temperature Control

Quick set digital control and display for easy monitoring.

Stainless Steel Interior

Durable and easy to clean for daily commercial use.

Full-Depth Cutting Boards

Preparation area designed for work station convenience and safe food handling.

TECHNICAL SPECIFICATIONS

MODEL	KCST27.8
Product Line	Sandwich/Salad Prep Table
Capacity (Cu. Ft.)	6.0
Condenser Type	Dynamic
Automatic Defrost Cooling System	Yes
Compressor Horsepower	1/5
Exterior Finish	Stainless Steel (430)
Interior Finish	Stainless Steel (304)
Cutting Board Dimensions (HxWxD)	.79x27.40x9.50
Pan Allocation	(6) 1/6 & (2) 1/9
Shelves (Number/Type)	1/Vinyl-Coated Steel
Control	Electronic
Temperature Range	32 to 50°F
Voltage Rating	115V/60Hz
Run Amps	5.3
Plug Type	NEMA 5-15P
Shipping Weight (Lbs.)	220
Warranty	3 Year/5 Year

kelvinator.com



6 CU. FT. SANDWICH / SALAD PREP TABLE

KCST27.8

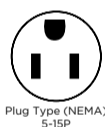
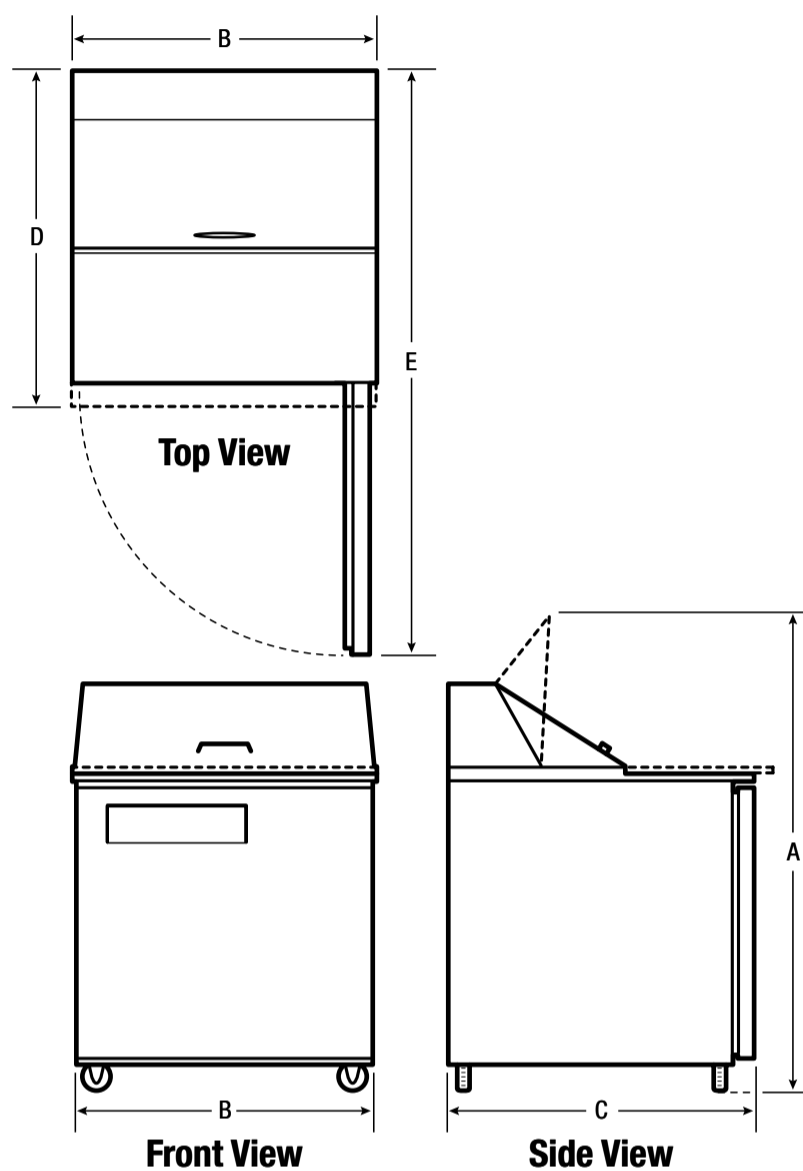

Plug Type (NEMA)
5-15P

EXTERIOR DIMENSIONS

Height with Lid Open (w/ Casters) A	47"
Width B	27"
Depth (Including Door & Handle) C	30"
Overall Depth (Including Cutting Board) D	30-5/8"
Depth (with Door 90° Open) E	54-1/2"

CERTIFICATIONS AND APPROVALS

Safety Certification	ETL
Sanitation Certification	ETL

ACCESSORIES

Shelf	5304486368
Shelf Clip	297121900
Pan Divider	5304486624
Cutting Board	5304486625



USA • 10200 David Taylor Drive • Charlotte, NC 28262 • 1-866-738-1640 • kelvinator.com
CANADA • 5855 Terry Fox Way • Mississauga, ON L5V 3E4

KCST27.8 06/15

© 2015 Electrolux Home Products, Inc.

High standards of quality at Electrolux Home Products, Inc. mean we are constantly working to improve our products. We reserve the right to change specifications or discontinue models without notice.



Dynamic Condenser improves performance in high temperature environments

Automatic Defrost Cooling System provides worry-free performance

1/3 HP Compressor

Stainless Steel Exterior & Interior

Electronic Control

Removable Door Gasket

Holds 1/6 Pans

Adjustable Shelves Vinyl-Coated Steel

Self-Closing Doors with 90-degree stay-open feature

Heavy Duty Casters



Electronic Digital Temperature Control

Quick set digital control and display for easy monitoring.

Stainless Steel Interior

Durable and easy to clean for daily commercial use.

Full-Depth Cutting Boards

Preparation area designed for work station convenience and safe food handling.

TECHNICAL SPECIFICATIONS

MODEL	KCST48.12
Product Line	Sandwich/Salad Prep Table
Capacity (Cu. Ft.)	12.0
Condenser Type	Dynamic
Automatic Defrost Cooling System	Yes
Compressor Horsepower	1/3
Exterior Finish	Stainless Steel (430)
Interior Finish	Stainless Steel (304)
Cutting Board Dimensions (HxWxD)	.79x46.69x10.55
Pan Allocation	(12) 1/6
Shelves (Number/Type)	2/Vinyl-Coated Steel
Control	Electronic
Temperature Range	32 to 50°F
Voltage Rating	115V/60Hz
Run Amps	7.8
Plug Type	NEMA 5-15P
Shipping Weight (Lbs.)	297
Warranty	3 Year/5 Year



12 CU. FT. SANDWICH / SALAD PREP TABLE

KCST48.12

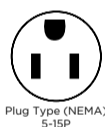
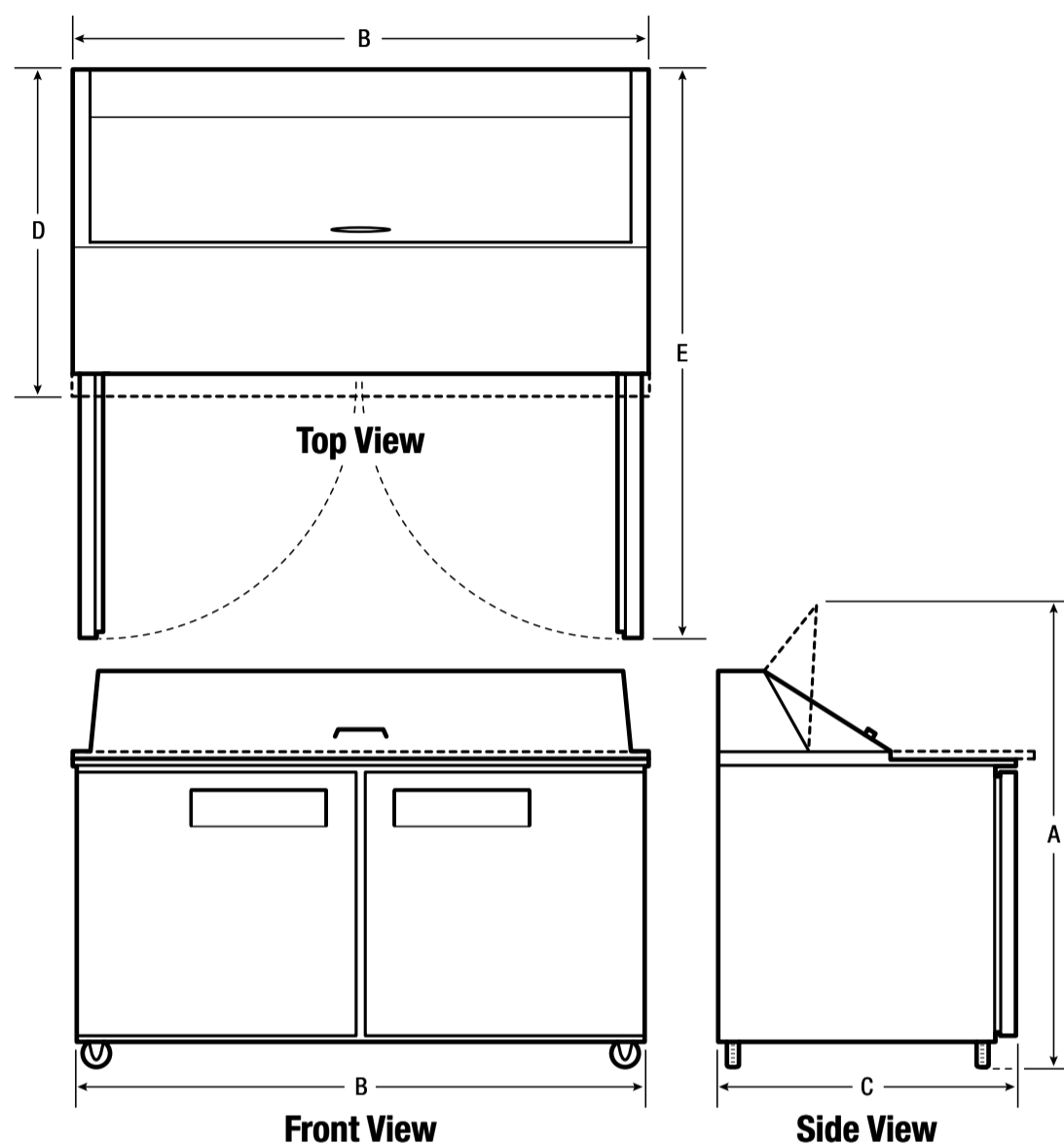

Plug Type (NEMA)
5-15P

EXTERIOR DIMENSIONS

Height with Lid Open (w/ Casters) A	51"
Width B	47"
Depth (Including Door & Handle) C	30"
Overall Depth (Including Cutting Board) D	30-5/8"
Depth (with Door 90° Open) E	54-1/2"

CERTIFICATIONS AND APPROVALS

Safety Certification	ETL
Sanitation Certification	ETL

ACCESSORIES

Shelf	5304486498
Shelf Clip	297121900
Pan Divider	5304486624
Cutting Board	5304486626



USA • 10200 David Taylor Drive • Charlotte, NC 28262 • 1-866-738-1640 • kelvinator.com
CANADA • 5855 Terry Fox Way • Mississauga, ON L5V 3E4

KCST48.12 06/15

© 2015 Electrolux Home Products, Inc.

High standards of quality at Electrolux Home Products, Inc. mean we are constantly working to improve our products. We reserve the right to change specifications or discontinue models without notice.



12 CU. FT. SANDWICH / SALAD PREP TABLE

KCST60.16



Fin & Tube Condenser improves performance in high temperature environments

Automatic Defrost Cooling System provides worry-free performance

1/5 HP Compressor

Stainless Steel Exterior & Interior

Electronic Control

Removable Door Gaskets

Holds 1/6 Pans

Adjustable Shelves Vinyl-Coated Steel

Self-Closing Doors with 90-degree stay-open feature

Heavy Duty Casters



Electronic Digital Temperature Control

Quick set digital control and display for easy monitoring.

Stainless Steel Interior

Durable and easy to clean for daily commercial use.

Full-Depth Cutting Board

Preparation area designed for work station convenience and safe food handling.

TECHNICAL SPECIFICATIONS

MODEL	KCST60.16
Product Line	Sandwich/Salad Prep Table
Capacity (Cu. Ft.)	12.0
Condenser Type	Fin & Tube
Automatic Defrost Cooling System	Yes
Compressor Horsepower	1/5
Exterior Finish	Stainless Steel (430)
Interior Finish	Stainless Steel (304)
Cutting Board Dimensions (HxWxD)	.79x60x8
Pan Allocation	(16) 1/6
Shelves (Number/Type)	2/Vinyl-Coated Steel
Control	Electronic
Temperature Range	32 to 50°F
Voltage Rating	115V/60Hz
Run Amps	5.3
Plug Type	NEMA 5-15P
Shipping Weight (Lbs.)	364
Warranty	3 Year/5 Year

kelvinator.com



12 CU. FT. SANDWICH / SALAD PREP TABLE

KCST60.16

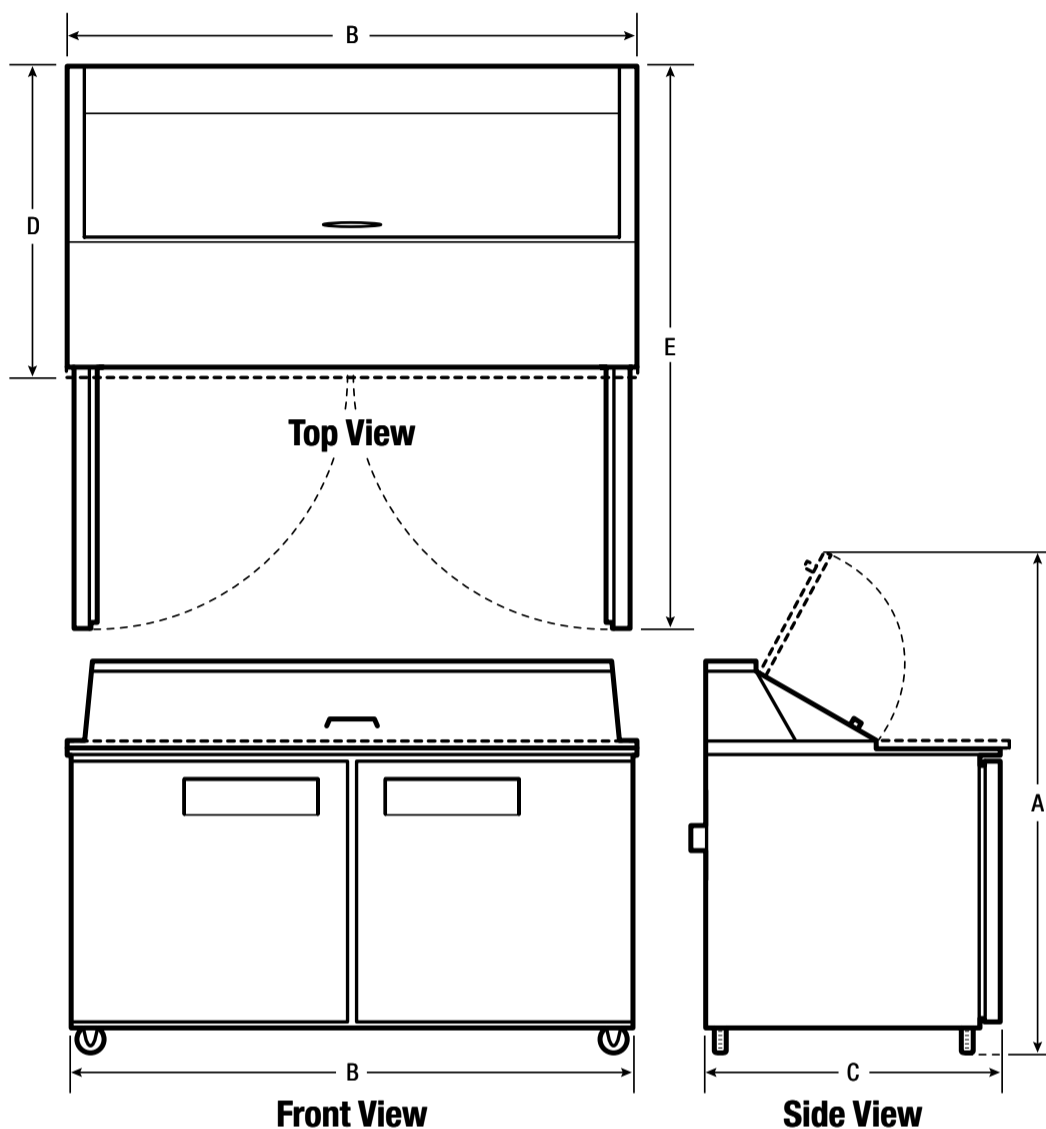

Plug Type (NEMA)
5-15P

EXTERIOR DIMENSIONS

Height with Lid Open (w/ Casters) A	47-3/4"
Width B	61-1/4"
Depth (Including Door & Handle) C	30"
Overall Depth (Including Cutting Board) D	29-1/4"
Depth (with Door 90° Open) E	55"

CERTIFICATIONS AND APPROVALS

Safety Certification	ETL
Sanitation Certification	ETL

ACCESSORIES

Shelf	5304497357
Shelf Clip	297121900
Pan Divider (End)	5304493460
Pan Divider (Middle)	5304493451
Cutting Board	5304497355



USA • 10200 David Taylor Drive • Charlotte, NC 28262 • 1-866-738-1640 • kelvinator.com
CANADA • 5855 Terry Fox Way • Mississauga, ON L5V 3E4

KCST60.16 06/15

© 2015 Electrolux Home Products, Inc.

High standards of quality at Electrolux Home Products, Inc. mean we are constantly working to improve our products. We reserve the right to change specifications or discontinue models without notice.



18 CU. FT. SANDWICH / SALAD PREP TABLE

KCST70.16



Dynamic Condenser improves performance in high temperature environments

Automatic Defrost Cooling System provides worry-free performance

1/2 HP Compressor

Stainless Steel Exterior & Interior

Electronic Control

Removable Door Gaskets

Holds 1/6 Pans

Adjustable Shelves Vinyl-Coated Steel

Self-Closing Doors with 90-degree stay-open feature

Heavy Duty Casters



Electronic Digital Temperature Control

Quick set digital control and display for easy monitoring.



Stainless Steel Interior

Durable and easy to clean for daily commercial use.



Full-Depth Cutting Boards

Preparation area designed for work station convenience and safe food handling.

TECHNICAL SPECIFICATIONS

MODEL	KCST70.16
Product Line	Sandwich/Salad Prep Table
Capacity (Cu. Ft.)	18.0
Condenser Type	Dynamic
Automatic Defrost Cooling System	Yes
Compressor Horsepower	1/2
Exterior Finish	Stainless Steel (430)
Interior Finish	Stainless Steel (304)
Cutting Board Dimensions (HxWxD)	.79 x 70.28 x 10.55
Pan Allocation	(16) 1/6
Shelves (Number/Type)	3/Vinyl-Coated Steel
Control	Electronic
Temperature Range	32 to 50°F
Voltage Rating	115V/60Hz
Run Amps	8.8
Plug Type	NEMA 5-15P
Shipping Weight (Lbs.)	388
Warranty	3 Year/5 Year

kelvinator.com



18 CU. FT. SANDWICH / SALAD PREP TABLE

KCST70.16

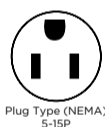
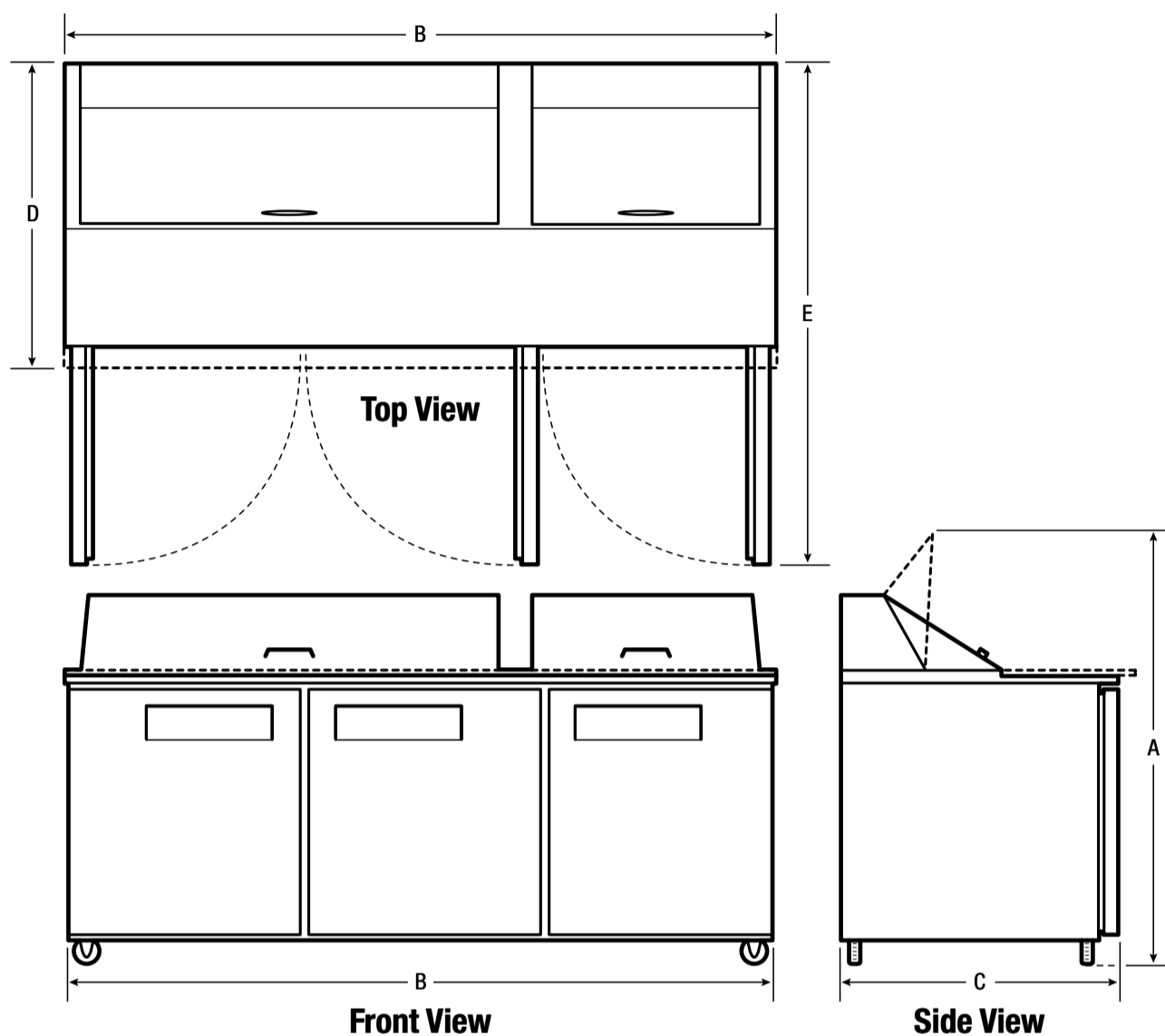

EXTERIOR DIMENSIONS

Height with Lid Open (w/ Casters) A	47-1/4"
Width B	70"
Depth (Including Door & Handle) C	30"
Overall Depth (Including Cutting Board) D	30-5/8"
Depth (with Door 90° Open) E	54-1/2"

CERTIFICATIONS AND APPROVALS

Safety Certification	ETL
Sanitation Certification	ETL

ACCESSORIES

Shelf	5304486545
Shelf Clip	297121900
Pan Divider	5304486624
Cutting Board	5304486627



USA • 10200 David Taylor Drive • Charlotte, NC 28262 • 1-866-738-1640 • kelvinator.com
 CANADA • 5855 Terry Fox Way • Mississauga, ON L5V 3E4

KCST70.16 06/15

© 2015 Electrolux Home Products, Inc.

High standards of quality at Electrolux Home Products, Inc. mean we are constantly working to improve our products. We reserve the right to change specifications or discontinue models without notice.



18 CU. FT. SANDWICH / SALAD PREP TABLE

KCST70.18



Fin & Tube Condenser improves performance in high temperature environments

Automatic Defrost Cooling System provides worry-free performance

1/2 HP Compressor

Stainless Steel Exterior & Interior

Electronic Controls

Removable Door Gaskets

Holds 1/6 Pans

Adjustable Shelves Vinyl-Coated Steel

Self-Closing Doors with 90-degree stay-open feature

Heavy Duty Casters



Electronic Digital Temperature Control

Quick set digital control and display for easy monitoring.

Stainless Steel Interior

Durable and easy to clean for daily commercial use.

Full-Depth Cutting Boards

Preparation area designed for work station convenience and safe food handling.

TECHNICAL SPECIFICATIONS

MODEL	KCST70.18
Product Line	Sandwich/Salad Prep Table
Capacity (Cu. Ft.)	18.0
Condenser Type	Fin & Tube
Automatic Defrost Cooling System	Yes
Compressor Horsepower	1/2
Exterior Finish	Stainless Steel (430)
Interior Finish	Stainless Steel (304)
Cutting Board Dimensions (HxWxD)	.79x70x8
Pan Allocation	(18) 1/6
Shelves (Number/Type)	3/Vinyl-Coated Steel
Control	Electronic
Temperature Range	32 to 50°F
Voltage Rating	115V/60Hz
Run Amps	8.8
Plug Type	NEMA 5-15P
Shipping Weight (Lbs.)	388
Warranty	3 Year/5 Year

kelvinator.com



18 CU. FT. SANDWICH / SALAD PREP TABLE

KCST70.18

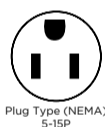
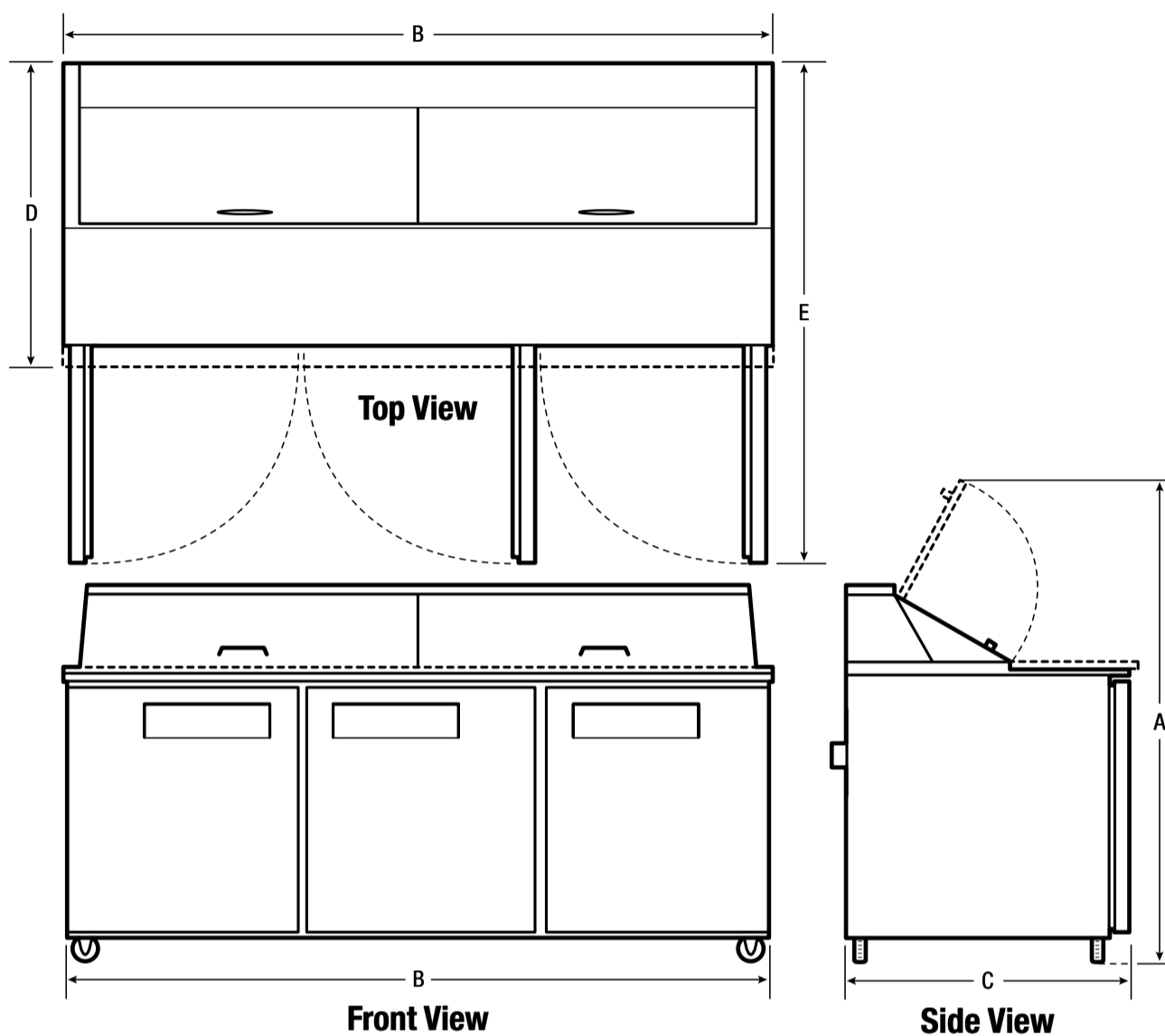

Plug Type (NEMA)
5-15P

EXTERIOR DIMENSIONS

Height with Lid Open (w/ Casters) A	47-3/4"
Width B	70-1/4"
Depth (Including Door & Handle) C	29-1/4"
Overall Depth (Including Cutting Board) D	30-1/2"
Depth (with Door 90° Open) E	55"

ACCESSORIES

Shelf	5304493593
Shelf Clip	297121900
Pan Divider (End)	5304493460
Pan Divider (Middle)	5304493451
Cutting Board	5304493521

CERTIFICATIONS AND APPROVALS

Safety Certification	ETL
Sanitation Certification	ETL



USA • 10200 David Taylor Drive • Charlotte, NC 28262 • 1-866-738-1640 • kelvinator.com
 CANADA • 5855 Terry Fox Way • Mississauga, ON L5V 3E4

KCST70.18 06/15

© 2015 Electrolux Home Products, Inc.

High standards of quality at Electrolux Home Products, Inc. mean we are constantly working to improve our products. We reserve the right to change specifications or discontinue models without notice.

6 CU. FT. MEGA TOP PREP TABLE

KCMT27.12



Dynamic Condenser improves performance in high temperature environments

Automatic Defrost Cooling System provides worry-free performance

1/4 HP Compressor

Stainless Steel Exterior & Interior

Electronic Control

Removable Door Gasket

Holds 1/6 & 1/9 Pans

Adjustable Shelves Vinyl-Coated Steel

Self-Closing Door with 90-degree stay-open feature

Heavy Duty Casters



Electronic Digital Temperature Control

Quick set digital control and display for easy monitoring.

Stainless Steel Interior

Durable and easy to clean for daily commercial use.

Full-Depth Cutting Boards

Preparation area designed for work station convenience and safe food handling.

TECHNICAL SPECIFICATIONS

MODEL	KCMT27.12
Product Line	Mega Top Prep Table
Capacity (Cu. Ft.)	6.0
Condenser Type	Dynamic
Automatic Defrost Cooling System	Yes
Compressor Horsepower	1/4
Exterior Finish	Stainless Steel (430)
Interior Finish	Stainless Steel (304)
Cutting Board Dimensions (HxWxD)	.79x27.40x6.97
Pan Allocation	(9) 1/6 & (3) 1/9
Shelves (Number/Type)	1/Vinyl-Coated Steel
Control	Electronic
Temperature Range	32 to 50°F
Voltage Rating	115V/60Hz
Run Amps	5.3
Plug Type	NEMA 5-15P
Shipping Weight (Lbs.)	242
Warranty	3 Year/5 Year



6 CU. FT. MEGA TOP PREP TABLE

KCMT27.12

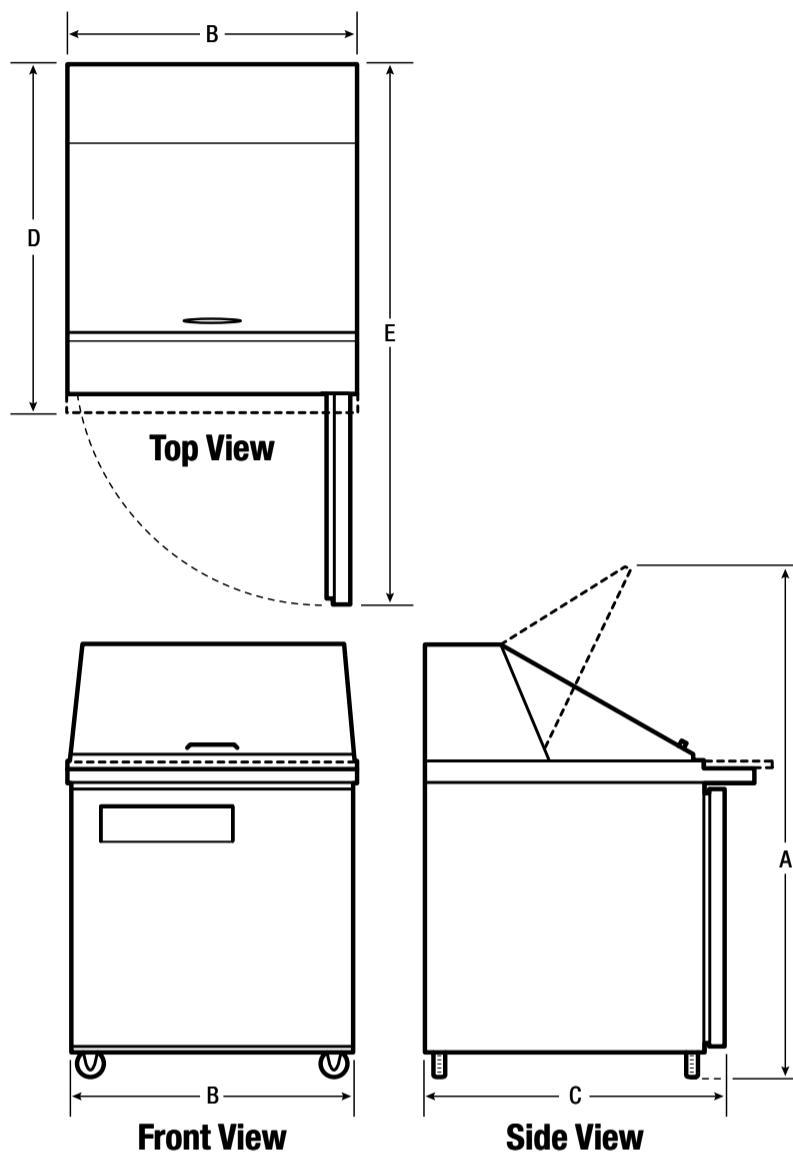

Plug Type (NEMA)
5-15P

EXTERIOR DIMENSIONS

Height with Lid Open (w/ Casters) A	47"
Width B	27"
Depth (Including Door & Handle) C	34"
Overall Depth (Including Cutting Board) D	34-5/16"
Depth (with Door 90° Open) E	54-1/2"

CERTIFICATIONS AND APPROVALS

Safety Certification	ETL
Sanitation Certification	ETL

ACCESSORIES

Shelf	5304486368
Shelf Clip	297121900
Pan Divider	5304486624
Cutting Board	5304486628



USA • 10200 David Taylor Drive • Charlotte, NC 28262 • 1-866-738-1640 • kelvinator.com

CANADA • 5855 Terry Fox Way • Mississauga, ON L5V 3E4

KCMT27.12 06/15

© 2015 Electrolux Home Products, Inc.

High standards of quality at Electrolux Home Products, Inc. mean we are constantly working to improve our products. We reserve the right to change specifications or discontinue models without notice.

12 CU. FT. MEGA TOP PREP TABLE

KCMT48.18



Dynamic Condenser improves performance in high temperature environments

Automatic Defrost Cooling System provides worry-free performance

1/3 HP Compressor

Stainless Steel Exterior & Interior

Electronic Control

Removable Door Gaskets

Holds 1/6 Pans

Adjustable Shelves Vinyl-Coated Steel

Self-Closing Doors with 90-degree stay-open feature

Heavy Duty Casters



Electronic Digital Temperature Control

Quick set digital control and display for easy monitoring.

Stainless Steel Interior

Durable and easy to clean for daily commercial use.

Full-Depth Cutting Boards

Preparation area designed for work station convenience and safe food handling.

TECHNICAL SPECIFICATIONS

MODEL	KCMT48.18
Product Line	Mega Top Prep Table
Capacity (Cu. Ft.)	12.0
Condenser Type	Dynamic
Automatic Defrost Cooling System	Yes
Compressor Horsepower	1/3
Exterior Finish	Stainless Steel (430)
Interior Finish	Stainless Steel (304)
Cutting Board Dimensions (HxWxD)	.79x46.69x6.97
Pan Allocation	(18) 1/6
Shelves (Number/Type)	2/Vinyl-Coated Steel
Control	Electronic
Temperature Range	32 to 50°F
Voltage Rating	115V/60Hz
Run Amps	7.8
Plug Type	NEMA 5-15P
Shipping Weight (Lbs.)	341
Warranty	3 Year/5 Year



12 CU. FT. MEGA TOP PREP TABLE

KCMT48.18

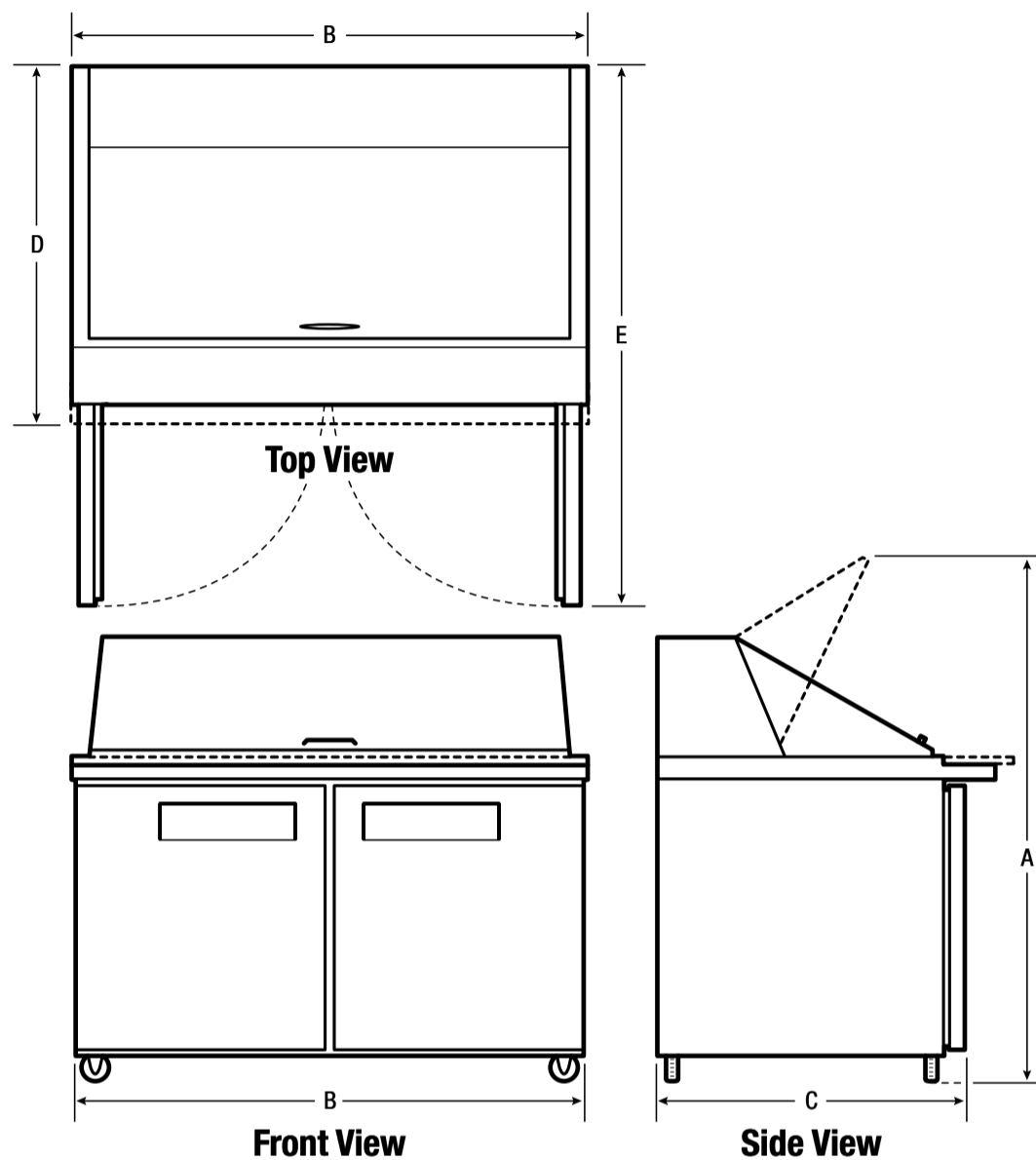

Plug Type (NEMA)
5-15P

EXTERIOR DIMENSIONS

Height with Lid Open (w/ Casters) A	47"
Width B	47"
Depth (Including Door & Handle) C	34"
Overall Depth (Including Cutting Board) D	34-5/16"
Depth (with Door 90° Open) E	54-1/2"

CERTIFICATIONS AND APPROVALS

Safety Certification	ETL
Sanitation Certification	ETL

ACCESSORIES

Shelf	5304486498
Shelf Clip	297121900
Pan Divider	5304486624
Cutting Board	5304486629



USA • 10200 David Taylor Drive • Charlotte, NC 28262 • 1-866-738-1640 • kelvinator.com
CANADA • 5855 Terry Fox Way • Mississauga, ON L5V 3E4

KCMT48.18 06/15

© 2015 Electrolux Home Products, Inc.

High standards of quality at Electrolux Home Products, Inc. mean we are constantly working to improve our products. We reserve the right to change specifications or discontinue models without notice.



12 CU. FT. MEGA TOP PREP TABLE

KCMT60.24



Fin & Tube Condenser improves performance in high temperature environments

Automatic Defrost Cooling System provides worry-free performance

1/3 HP Compressor

Stainless Steel Exterior & Interior

Electronic Control

Removable Door Gaskets

Holds 1/6 Pans

Adjustable Shelves Vinyl-Coated Steel

Self-Closing Doors with 90-degree stay-open feature

Heavy Duty Casters



Electronic Digital Temperature Control

Quick set digital control and display for easy monitoring.

Stainless Steel Interior

Durable and easy to clean for daily commercial use.

Full-Depth Cutting Boards

Preparation area designed for work station convenience and safe food handling.

TECHNICAL SPECIFICATIONS

MODEL	KCMT60.24
Product Line	Mega Top Prep Table
Capacity (Cu. Ft.)	12.0
Condenser Type	Fin & Tube
Automatic Defrost Cooling System	Yes
Compressor Horsepower	1/3
Exterior Finish	Stainless Steel (430)
Interior Finish	Stainless Steel (304)
Cutting Board Dimensions (HxWxD)	.79x60x11.5
Pan Allocation	(24) 1/6
Shelves (Number/Type)	2/Vinyl-Coated Steel
Control	Electronic
Temperature Range	32 to 50°F
Voltage Rating	115V/60Hz
Run Amps	5.3
Plug Type	NEMA 5-15P
Shipping Weight (Lbs.)	386
Warranty	3 Year/5 Year

kelvinator.com



12 CU. FT. MEGA TOP PREP TABLE

KCMT60.24

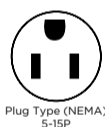
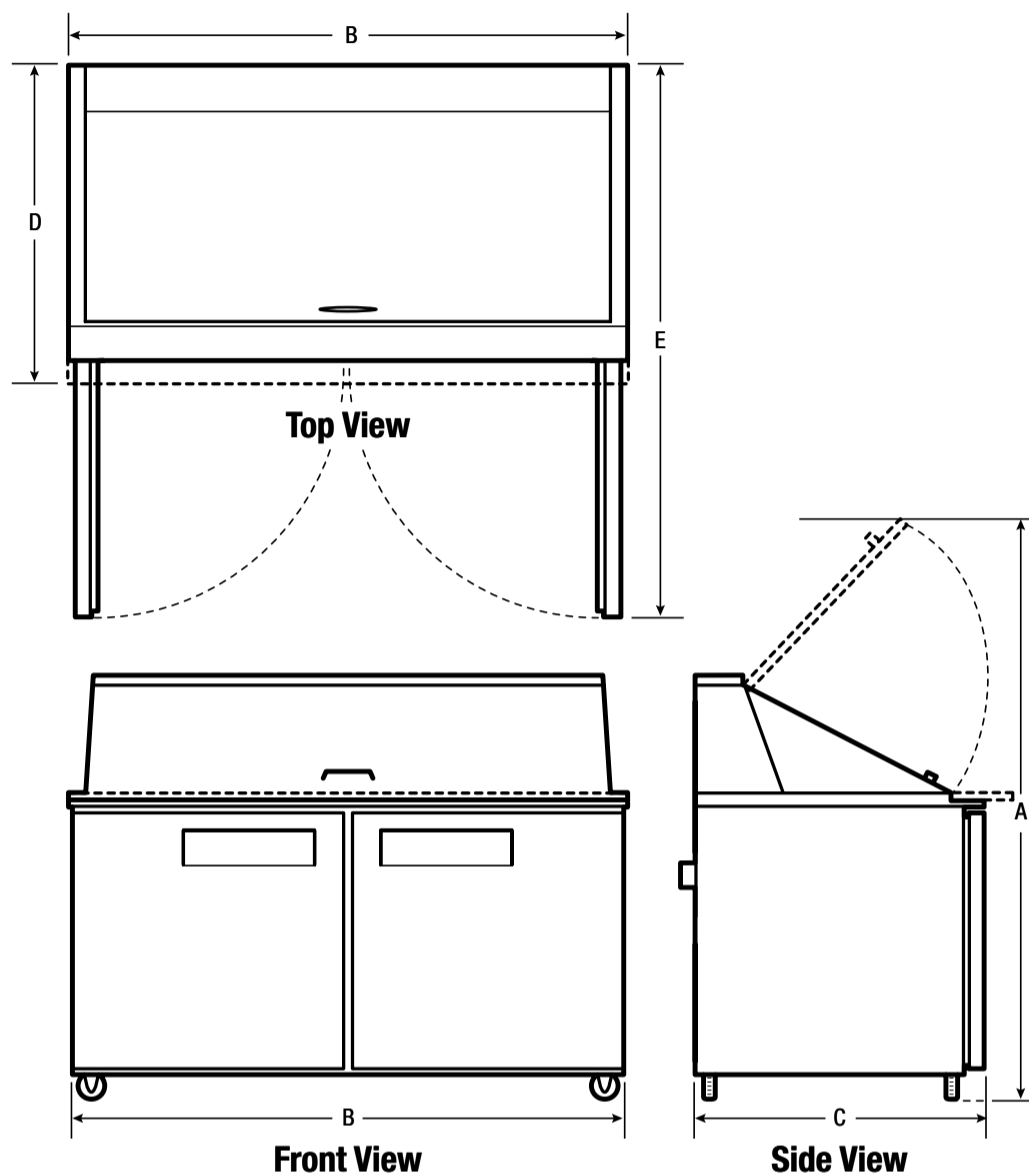

Plug Type (NEMA)
5-15P

EXTERIOR DIMENSIONS

Height with Lid Open (w/ Casters) A	52"
Width B	60"
Depth (Including Door & Handle) C	29-1/4"
Overall Depth (Including Cutting Board) D	35"
Depth (with Door 90° Open) E	55"

CERTIFICATIONS AND APPROVALS

Safety Certification	ETL
Sanitation Certification	ETL

ACCESSORIES

Shelf	5304497357
Shelf Clip	297121900
Pan Divider	5304493390
Cutting Board	5304497356



USA • 10200 David Taylor Drive • Charlotte, NC 28262 • 1-866-738-1640 • kelvinator.com
CANADA • 5855 Terry Fox Way • Mississauga, ON L5V 3E4

KCMT60.24 06/15

© 2015 Electrolux Home Products, Inc.

High standards of quality at Electrolux Home Products, Inc. mean we are constantly working to improve our products. We reserve the right to change specifications or discontinue models without notice.



18 CU. FT. MEGA TOP PREP TABLE

KCMT70.27



Dynamic Condenser improves performance in high temperature environments

Automatic Defrost Cooling System provides worry-free performance

1/3 HP Compressor

Stainless Steel Exterior & Interior

Electronic Control

Removable Door Gaskets

Holds 1/6 Pans

Adjustable Shelves Vinyl-Coated Steel

Self-Closing Doors with 90-degree stay-open feature

Heavy Duty Casters



Electronic Digital Temperature Control

Quick set digital control and display for easy monitoring.

Stainless Steel Interior

Durable and easy to clean for daily commercial use.

Full-Depth Cutting Boards

Preparation area designed for work station convenience and safe food handling.

TECHNICAL SPECIFICATIONS

MODEL	KCMT70.27
Product Line	Mega Top Prep Table
Capacity (Cu. Ft.)	18.0
Condenser Type	Dynamic
Automatic Defrost Cooling System	Yes
Compressor Horsepower	1/3
Exterior Finish	Stainless Steel (430)
Interior Finish	Stainless Steel (304)
Cutting Board Dimensions (HxWxD)	.79x70.28x6.97
Pan Allocation	(27) 1/6
Shelves (Number/Type)	2/Vinyl-Coated Steel
Control	Electronic
Temperature Range	32 to 50°F
Voltage Rating	115V/60Hz
Run Amps	9.2
Plug Type	NEMA 5-15P
Shipping Weight (Lbs.)	484
Warranty	3 Year/5 Year

kelvinator.com



18 CU. FT. MEGA TOP PREP TABLE

KCMT70.27

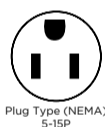
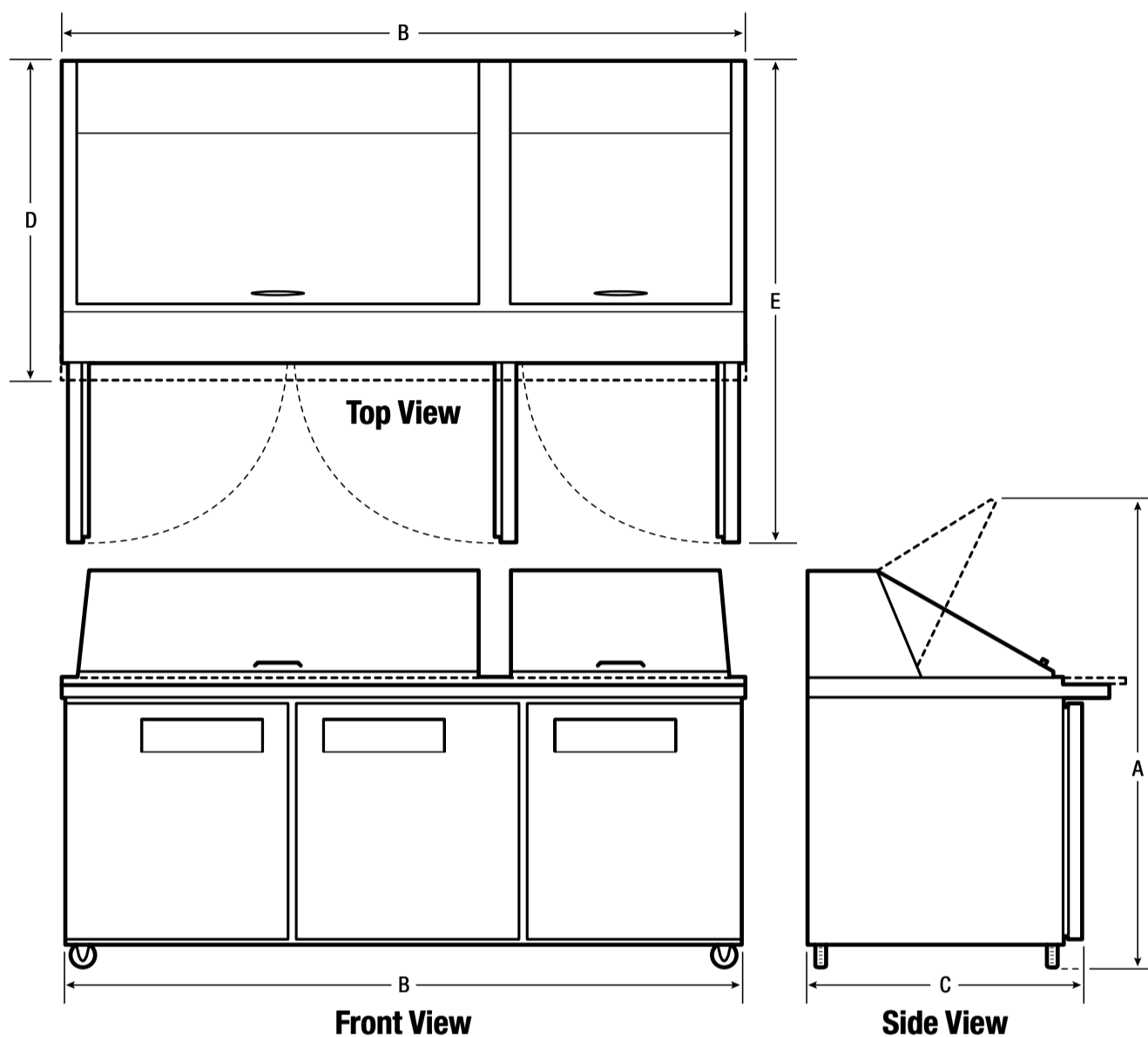

Plug Type (NEMA)
5-15P

EXTERIOR DIMENSIONS

Height with Lid Open (w/ Casters) A	51-1/4"
Width B	70"
Depth (Including Door & Handle) C	34"
Overall Depth (Including Cutting Board) D	34-5/16"
Depth (with Door 90° Open) E	54-1/2"

CERTIFICATIONS AND APPROVALS

Safety Certification	ETL
Sanitation Certification	ETL

ACCESSORIES

Shelf	5304486545
Shelf Clip	297121900
Pan Divider	5304486624
Cutting Board	5304486630



USA • 10200 David Taylor Drive • Charlotte, NC 28262 • 1-866-738-1640 • kelvinator.com
CANADA • 5855 Terry Fox Way • Mississauga, ON L5V 3E4

KCMT70.27 06/15

© 2015 Electrolux Home Products, Inc.

High standards of quality at Electrolux Home Products, Inc. mean we are constantly working to improve our products. We reserve the right to change specifications or discontinue models without notice.



18 CU. FT. MEGA TOP PREP TABLE

KCMT70.30



Fin & Tube Condenser improves performance in high temperature environments

Automatic Defrost Cooling System provides worry-free performance

1/2 HP Compressor

Stainless Steel Exterior & Interior

Electronic Control

Removable Door Gaskets

Holds 1/6 Pans

Adjustable Shelves Vinyl-Coated Steel

Self-Closing Doors with 90-degree stay-open feature

Heavy Duty Casters



Electronic Digital Temperature Control

Quick set digital control and display for easy monitoring.

Stainless Steel Interior

Durable and easy to clean for daily commercial use.

Full-Depth Cutting Boards

Preparation area designed for work station convenience and safe food handling.

TECHNICAL SPECIFICATIONS

MODEL	KCMT70.30
Product Line	Mega Top Prep Table
Capacity (Cu. Ft.)	18.0
Condenser Type	Fin & Tube
Automatic Defrost Cooling System	Yes
Compressor Horsepower	1/2
Exterior Finish	Stainless Steel (430)
Interior Finish	Stainless Steel (304)
Cutting Board Dimensions (HxWxD)	.79x70x8
Pan Allocation	(30) 1/6
Shelves (Number/Type)	3/Vinyl-Coated Steel
Control	Electronic
Temperature Range	32 to 50°F
Voltage Rating	115V/60Hz
Run Amps	9.2
Plug Type	NEMA 5-15P
Shipping Weight (Lbs.)	484
Warranty	3 Year/5 Year

kelvinator.com



18 CU. FT. MEGA TOP PREP TABLE

KCMT70.30

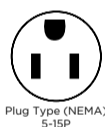
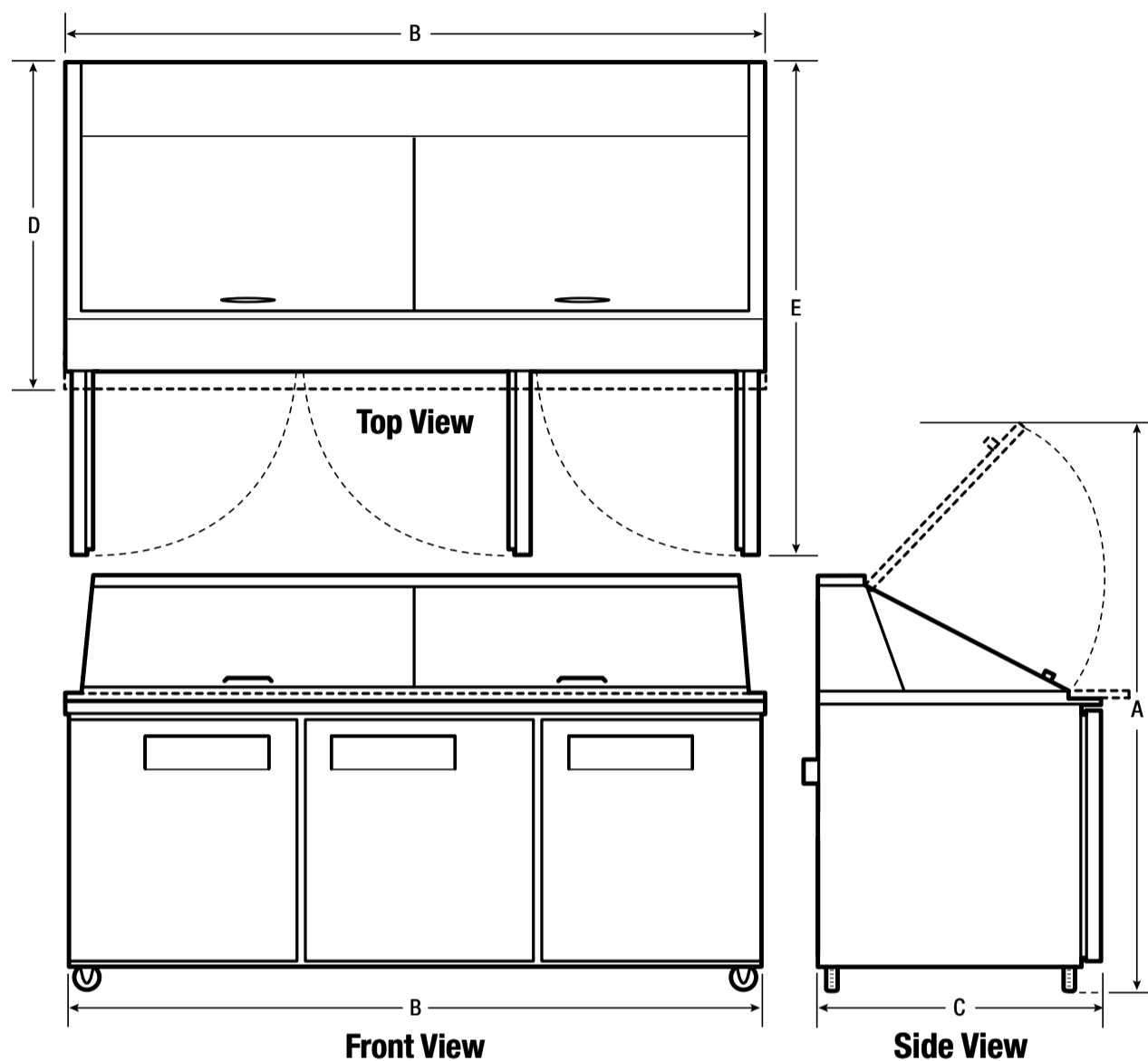

EXTERIOR DIMENSIONS

Height with Lid Open (w/ Casters) A	52"
Width B	70-1/4"
Depth (Including Door & Handle) C	29-1/4"
Overall Depth (Including Cutting Board) D	35"
Depth (with Door 90° Open) E	55"

CERTIFICATIONS AND APPROVALS

Safety Certification	ETL
Sanitation Certification	ETL

ACCESSORIES

Shelf	5304493593
Shelf Clip	297121900
Pan Divider	5304493390
Cutting Board	5304493522



USA • 10200 David Taylor Drive • Charlotte, NC 28262 • 1-866-738-1640 • kelvinator.com
CANADA • 5855 Terry Fox Way • Mississauga, ON L5V 3E4

KCMT70.30 06/15

© 2015 Electrolux Home Products, Inc.

High standards of quality at Electrolux Home Products, Inc. mean we are constantly working to improve our products. We reserve the right to change specifications or discontinue models without notice.

9 CU. FT. PIZZA PREP TABLE

KCPT50.6



Fin & Tube Condenser improves performance in high temperature environments

Automatic Defrost Cooling System provides worry-free performance

1/4 HP Compressor

Stainless Steel Exterior & Interior

Electronic Control

Removable Door Gaskets

Holds 1/3 Pans

Adjustable Shelves Vinyl-Coated Steel

Self-Closing Doors with 90-degree stay-open feature

Heavy Duty Casters



Electronic Digital Temperature Control

Quick set digital control and display for easy monitoring.

Stainless Steel Interior

Durable and easy to clean for daily commercial use.

Full-Depth Cutting Boards

Preparation area designed for work station convenience and safe food handling.

TECHNICAL SPECIFICATIONS

MODEL	KCPT50.6
Product Line	Pizza Prep Table
Capacity (Cu. Ft.)	9.0
Condenser Type	Fin & Tube
Automatic Defrost Cooling System	Yes
Compressor Horsepower	1/4
Exterior Finish	Stainless Steel (430)
Interior Finish	Stainless Steel (304)
Cutting Board Dimensions (HxWxD)	.79x50x19.5
Pan Allocation	(6) 1/3
Shelves (Number/Type)	1/Vinyl-Coated Steel
Control	Electronic
Temperature Display Location	External
Temperature Range	32 to 50°F
Voltage Rating	115V/60Hz
Run Amps	9.8
Plug Type	NEMA 5-15P
Shipping Weight (Lbs.)	331
Warranty	3 Year/5 Year



9 CU. FT. PIZZA PREP TABLE

KCPT50.6

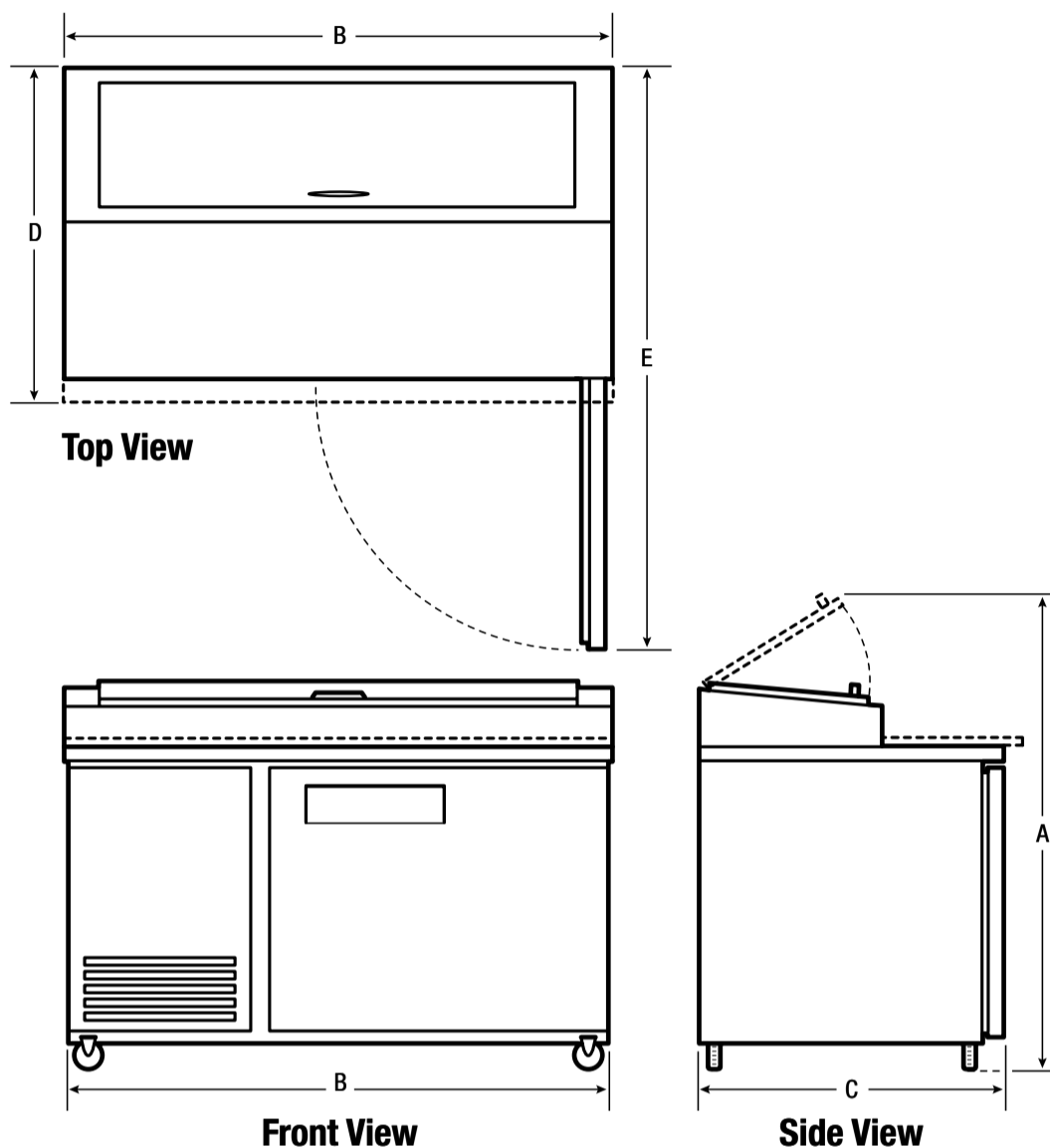

Plug Type (NEMA)
5-15P

EXTERIOR DIMENSIONS

Height with Lid Open (w/ Casters) A	56-3/4"
Width B	60"
Depth (Including Door & Handle) C	31-1/4"
Overall Depth (Including Cutting Board) D	37-3/4"
Depth (with Door 90° Open) E	54"

CERTIFICATIONS AND APPROVALS

Safety Certification	ETL
Sanitation Certification	ETL

ACCESSORIES

Shelf	5304493484
Shelf Clip	297121900
Pan Divider (End)	5304493482
Pan Divider (Middle)	5304493481
Cutting Board	5304497353



USA • 10200 David Taylor Drive • Charlotte, NC 28262 • 1-866-738-1640 • kelvinator.com
CANADA • 5855 Terry Fox Way • Mississauga, ON L5V 3E4

KCPT50.6 06/15

© 2015 Electrolux Home Products, Inc.

High standards of quality at Electrolux Home Products, Inc. mean we are constantly working to improve our products. We reserve the right to change specifications or discontinue models without notice.

16 CU. FT. PIZZA PREP TABLE

KCPT72.9



Dynamic Condenser improves performance in high temperature environments

Automatic Defrost Cooling System provides worry-free performance

1/3 HP Compressor

Stainless Steel Exterior & Interior

Electronic Control

Removable Door Gaskets

Holds 1/3 Pans

Adjustable Shelves Vinyl-Coated Steel

Self-Closing Doors with 90-degree stay-open feature

Heavy Duty Casters



Electronic Digital Temperature Control

Quick set digital control and display for easy monitoring.

Stainless Steel Interior

Durable and easy to clean for daily commercial use.

Full-Depth Cutting Boards

Preparation area designed for work station convenience and safe food handling.

TECHNICAL SPECIFICATIONS

MODEL	KCPT72.9
Product Line	Pizza Prep Table
Capacity (Cu.Ft.)	16.0
Condenser Type	Dynamic
Automatic Defrost Cooling System	Yes
Compressor Horsepower	1/3
Exterior Finish	Stainless Steel (430)
Interior Finish	Stainless Steel (304)
Cutting Board Dimensions (HxWxD)	.79 x 70.79 x 19.53
Pan Allocation	(9) 1/3
Shelves (Number/Type)	2/Vinyl-Coated Steel
Control	Electronic
Temperature Display Location	External
Temperature Range	32 to 50°F
Voltage Rating	115V/60Hz
Run Amps	9.8
Plug Type	NEMA 5-15P
Shipping Weight (Lbs.)	453
Warranty	3 Year/5 Year



16 CU. FT. PIZZA PREP TABLE

KCPT72.9

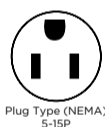
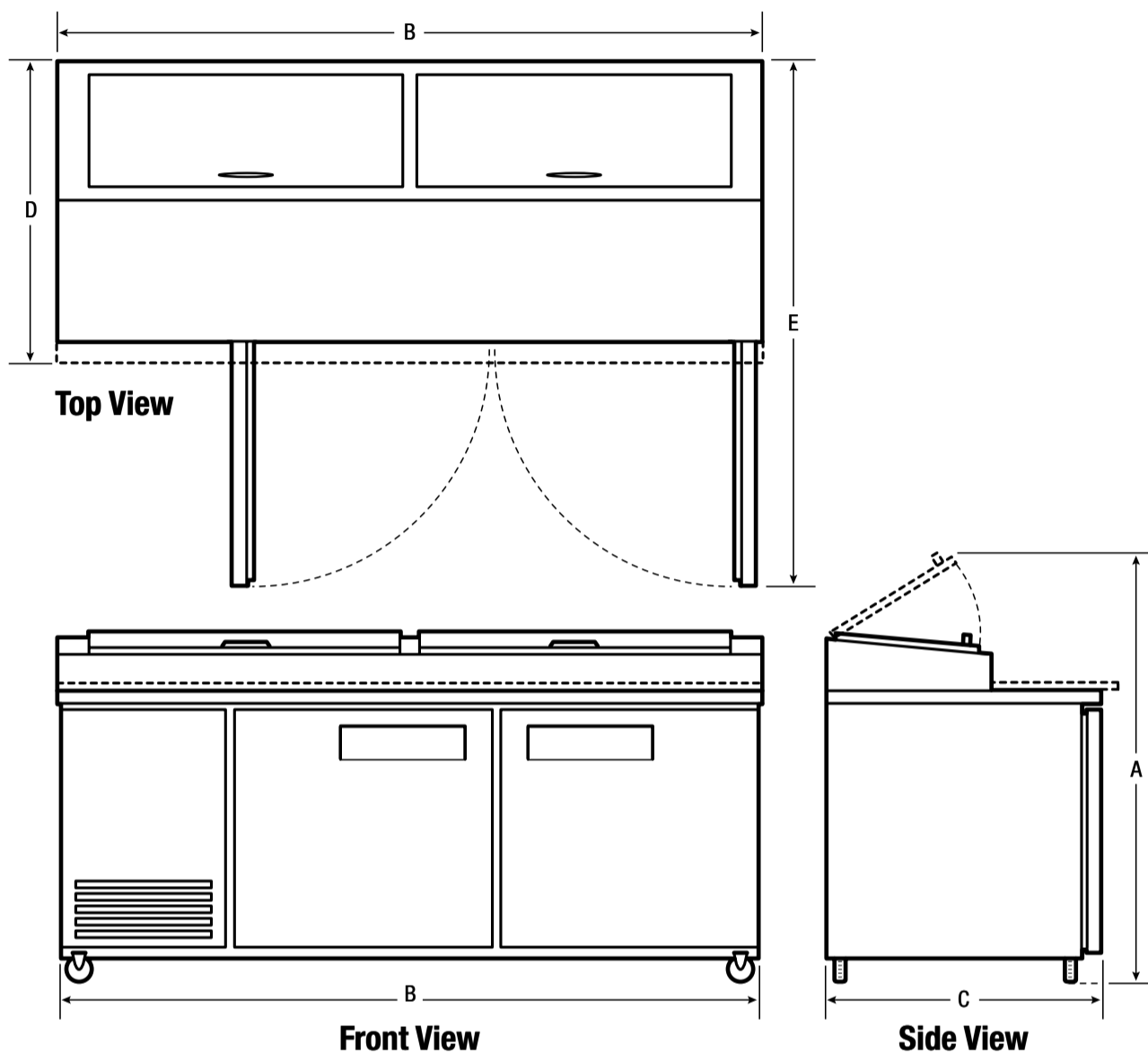

EXTERIOR DIMENSIONS

Height with Lid Open (w/ Casters) A	57-1/2"
Width B	71"
Depth (Including Door & Handle) C	32"
Overall Depth (Including Cutting Board) D	37-13/16"
Depth (with Door 90° Open) E	54-15/16"

CERTIFICATIONS AND APPROVALS

Safety Certification	ETL
Sanitation Certification	ETL

ACCESSORIES

Shelf	5304486796
Shelf Clip	297121900
Pan Divider	5304486621
Cutting Board	5304486622



USA • 10200 David Taylor Drive • Charlotte, NC 28262 • 1-866-738-1640 • kelvinator.com

CANADA • 5855 Terry Fox Way • Mississauga, ON L5V 3E4

KCPT72.9 06/15

© 2015 Electrolux Home Products, Inc.

High standards of quality at Electrolux Home Products, Inc. mean we are constantly working to improve our products. We reserve the right to change specifications or discontinue models without notice.

24 CU. FT. PIZZA PREP TABLE

KCPT92.12



Dynamic Condenser improves performance in high temperature environments

Automatic Defrost Cooling System provides worry-free performance

1/2 HP Compressor

Stainless Steel Exterior & Interior

Electronic Control

External Temperature Display

Removable Door Gaskets

Holds 1/3 Pans

Adjustable Shelves Vinyl-Coated Steel

Self-Closing Doors with 90-degree stay-open feature

Heavy Duty Casters



Electronic Digital Temperature Control

Quick set digital control and display for easy monitoring.

Stainless Steel Interior

Durable and easy to clean for daily commercial use.

Full-Depth Cutting Boards

Preparation area designed for work station convenience and safe food handling.

TECHNICAL SPECIFICATIONS

MODEL	KCPT92.12
Product Line	Pizza Prep Table
Capacity (Cu. Ft.)	24.0
Condenser Type	Dynamic
Automatic Defrost Cooling System	Yes
Compressor Horsepower	1/2
Exterior Finish	Stainless Steel (430)
Interior Finish	Stainless Steel (304)
Cutting Board Dimensions (HxWxD)	.79x91.81 x 19.53
Pan Allocation	(12) 1/3
Shelves (Number/Type)	3/Vinyl-Coated Steel
Control	Electronic
Temperature Display Location	External
Temperature Range	32 to 50°F
Voltage Rating	115V/60Hz
Run Amps	10.5
Plug Type	NEMA 5-15P
Shipping Weight (Lbs.)	489
Warranty	3 Year/5 Year



24 CU. FT. PIZZA PREP TABLE

KCPT92.12

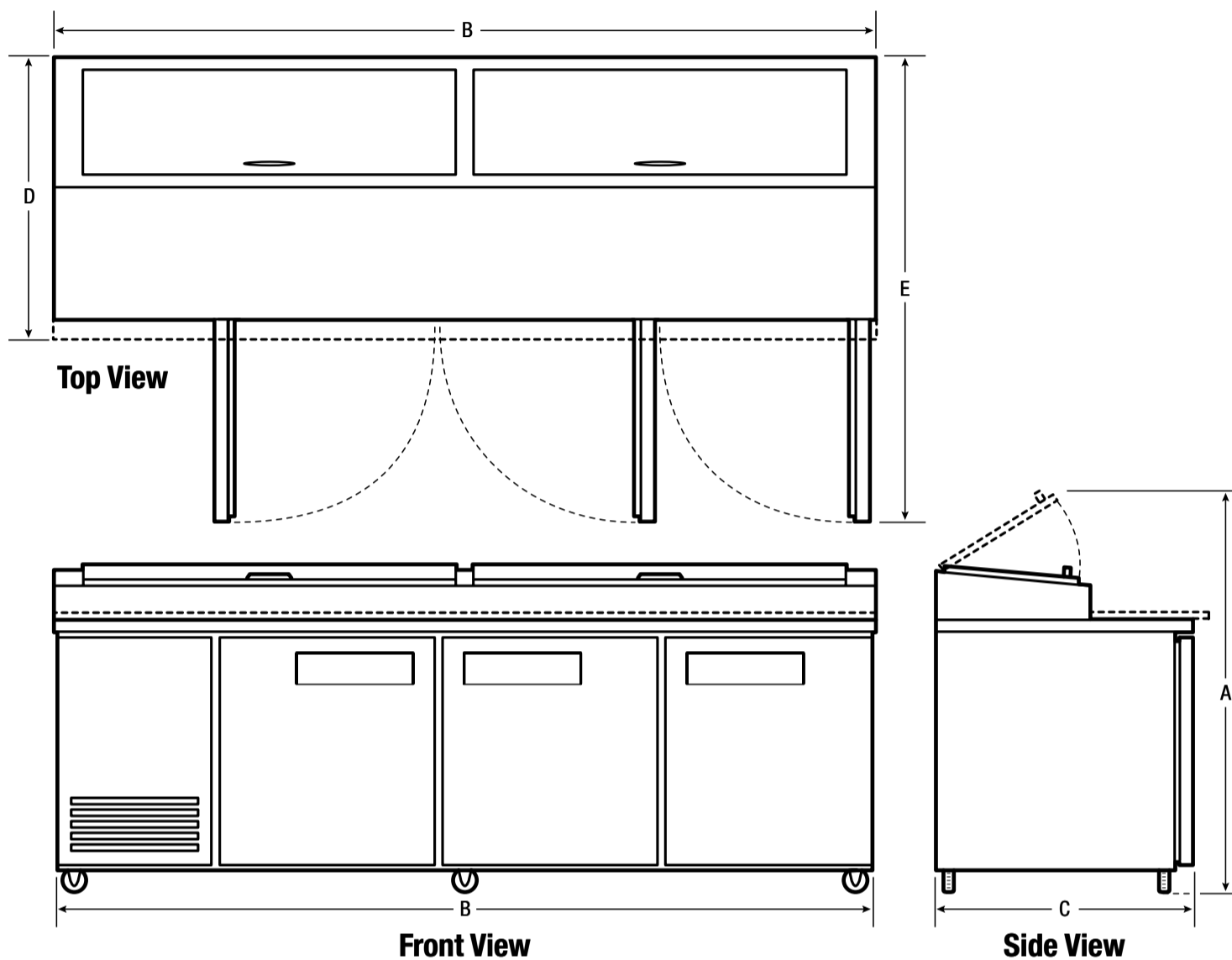

EXTERIOR DIMENSIONS

Height with Lid Open (w/ Casters) A	57-1/2"
Width B	92"
Depth (Including Door & Handle) C	32"
Overall Depth (Including Cutting Board) D	37-13/16"
Depth (with Door 90° Open) E	54-15/16"

CERTIFICATIONS AND APPROVALS

Safety Certification	ETL
Sanitation Certification	ETL

ACCESSORIES

Shelf	5304486826
Shelf Clip	297121900
Pan Divider	5304486621
Cutting Board	5304486623



USA • 10200 David Taylor Drive • Charlotte, NC 28262 • 1-866-738-1640 • kelvinator.com

CANADA • 5855 Terry Fox Way • Mississauga, ON L5V 3E4

KCPT92.12 06/15

© 2015 Electrolux Home Products, Inc.

High standards of quality at Electrolux Home Products, Inc. mean we are constantly working to improve our products. We reserve the right to change specifications or discontinue models without notice.

Kelvinator 



UNDER-COUNTERS

6 CU. FT. UNDER-COUNTER REFRIGERATOR

KCUC27R



Dynamic Condenser improves performance in high temperature environments

Automatic Defrost Cooling System provides worry-free performance

1/5 HP Compressor

Stainless Steel Exterior & Interior

Electronic Control

External Temperature Display

Removable Door Gasket

Adjustable Shelves Vinyl-Coated Steel

Self-Closing Door with 90-degree stay-open feature

Heavy Duty Casters

Reversible Door



Electronic Digital Temperature Control

Quick set digital control and display for easy monitoring.

Stainless Steel Interior

Durable and easy to clean for daily commercial use.

Vinyl Heavy Duty Adjustable Shelves

Shelves that are easy to handle and keep clean.

TECHNICAL SPECIFICATIONS

MODEL	KCUC27R
Product Line	Refrigerator
Capacity (Cu. Ft.)	6.0
Condenser Type	Dynamic
Automatic Defrost Cooling System	Yes
Compressor Horsepower	1/5
Exterior Finish	Stainless Steel (430)
Interior Finish	Stainless Steel (304)
Shelves (Number/Type)	1/Vinyl-Coated Steel
Control	Electronic
Temperature Display Location	External
Temperature Range	32 to 50°F
Voltage Rating	115V/60Hz
Run Amps	5.0
Plug Type	NEMA 5-15P
Shipping Weight (Lbs.)	207
Warranty	3 Year/5 Year



6 CU. FT. UNDER-COUNTER REFRIGERATOR

KCUC27R

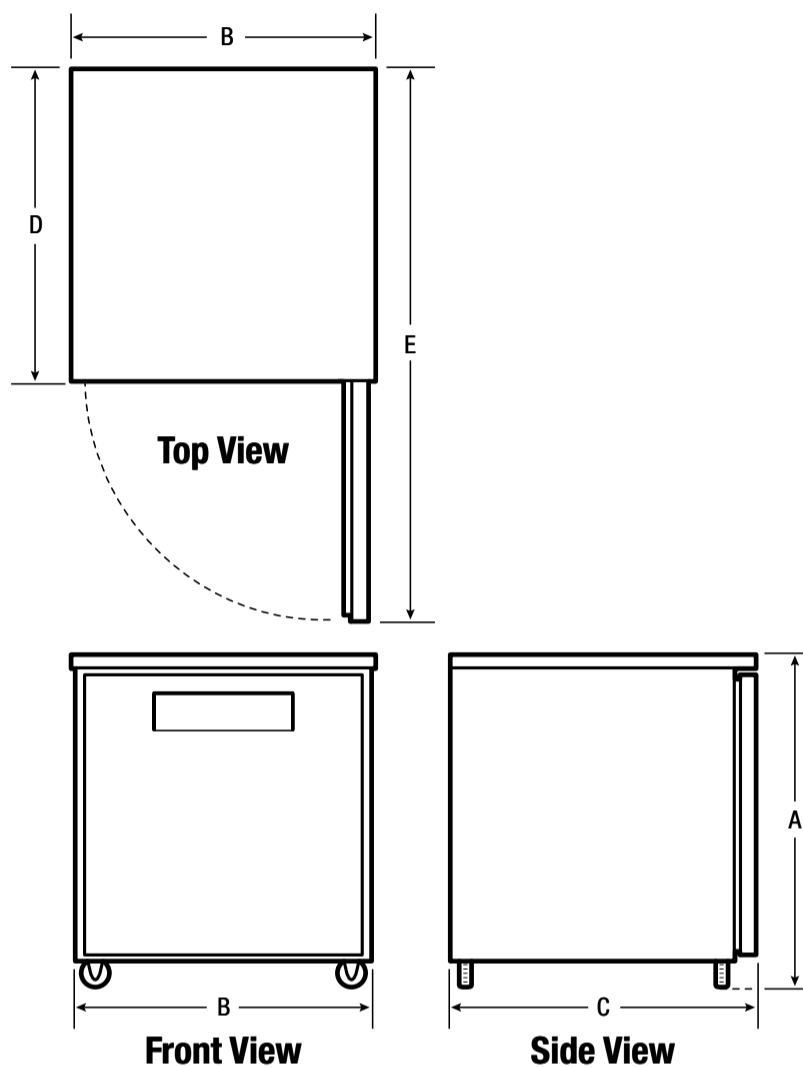

Plug Type (NEMA)
5-15P

EXTERIOR DIMENSIONS

Height A (Including Casters)	35"
Width B	27"
Overall Depth (Including Door & Handle) C	30"
Cabinet Depth D	27-1/16"
Depth (with Door 90° Open) E	54-1/2"

CERTIFICATIONS AND APPROVALS

Safety Certification	ETL
Sanitation Certification	ETL

ACCESSORIES

Shelf	5304486887
Shelf Clip	297121900



USA • 10200 David Taylor Drive • Charlotte, NC 28262 • 1-866-738-1640 • kelvinator.com
CANADA • 5855 Terry Fox Way • Mississauga, ON L5V 3E4

KCUC27R 06/15

© 2015 Electrolux Home Products, Inc.

High standards of quality at Electrolux Home Products, Inc. mean we are constantly working to improve our products. We reserve the right to change specifications or discontinue models without notice.



12 CU. FT. UNDER-COUNTER REFRIGERATOR

KCUC48R



Dynamic Condenser improves performance in high temperature environments

Automatic Defrost Cooling System provides worry-free performance

1/3 HP Compressor

Stainless Steel Exterior & Interior

Electronic Control

External Temperature Display

Removable Door Gaskets

Adjustable Shelves Vinyl-Coated Steel

Self-Closing Doors with 90-degree stay-open feature

Heavy Duty Casters



Electronic Digital Temperature Control

Quick set digital control and display for easy monitoring.

Stainless Steel Interior

Durable and easy to clean for daily commercial use.

Vinyl Heavy Duty Adjustable Shelves

Shelves that are easy to handle and keep clean.

TECHNICAL SPECIFICATIONS

MODEL	KCUC48R
Product Line	Refrigerator
Capacity (Cu. Ft.)	12.0
Condenser Type	Dynamic
Automatic Defrost Cooling System	Yes
Compressor Horsepower	1/3
Exterior Finish	Stainless Steel (430)
Interior Finish	Stainless Steel (304)
Shelves (Number/Type)	2/Vinyl-Coated Steel
Control	Electronic
Temperature Display Location	External
Temperature Range	32 to 50°F
Voltage Rating	115V/60Hz
Run Amps	5.4
Plug Type	NEMA 5-15P
Shipping Weight (Lbs.)	299
Warranty	3 Year/5 Year



12 CU. FT. UNDER-COUNTER REFRIGERATOR

KCUC48R

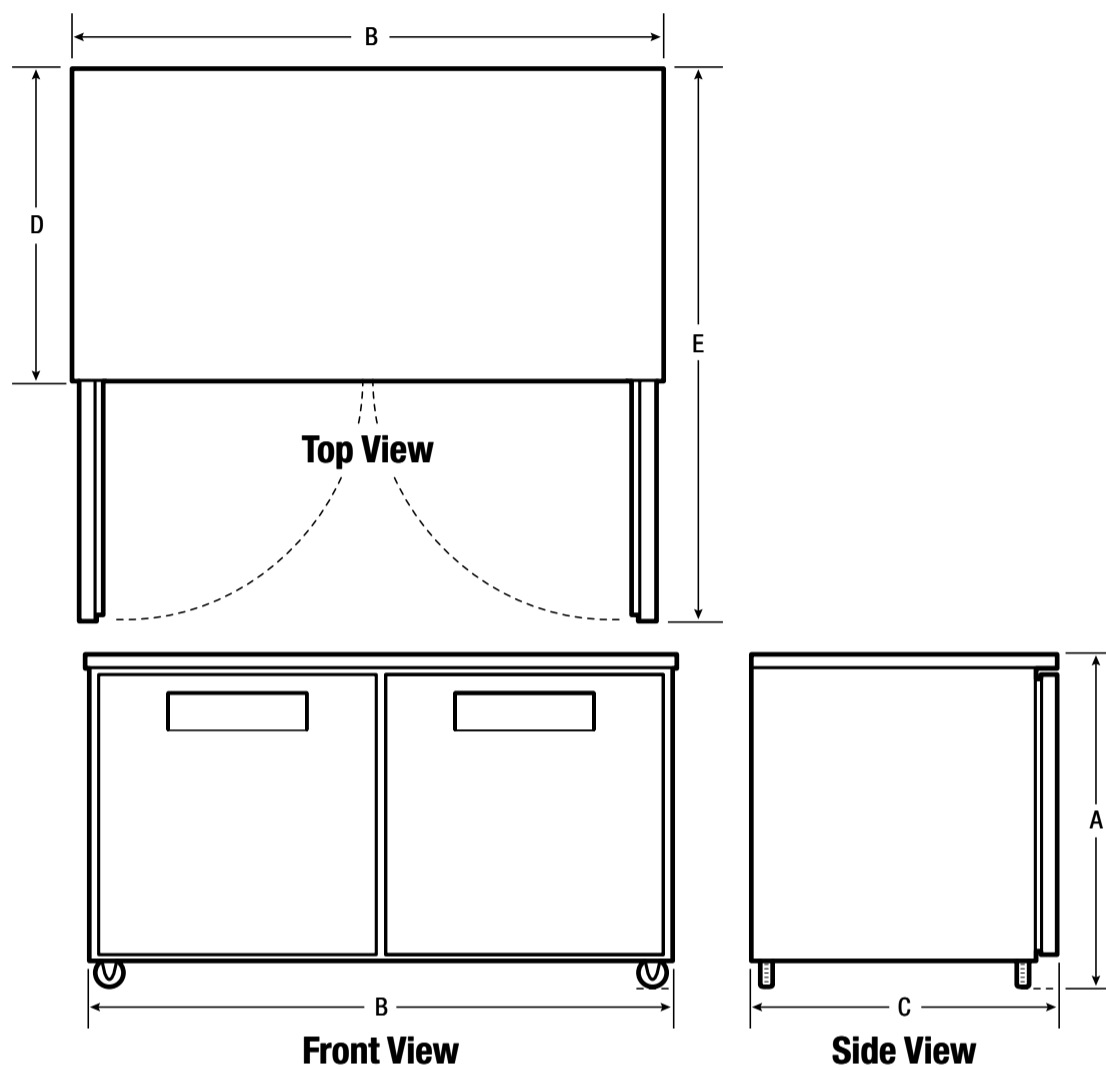

Plug Type (NEMA)
5-15P

EXTERIOR DIMENSIONS

Height A (Including Casters)	35"
Width B	47"
Overall Depth (Including Door & Handle) C	30"
Cabinet Depth D	27-1/16"
Depth (with Door 90° Open) E	54-1/2"

CERTIFICATIONS AND APPROVALS

Safety Certification	ETL
Sanitation Certification	ETL

ACCESSORIES

Shelf	5304486998
Shelf Clip	297121900



USA • 10200 David Taylor Drive • Charlotte, NC 28262 • 1-866-738-1640 • kelvinator.com
CANADA • 5855 Terry Fox Way • Mississauga, ON L5V 3E4

KCUC48R 06/15

© 2015 Electrolux Home Products, Inc.

High standards of quality at Electrolux Home Products, Inc. mean we are constantly working to improve our products. We reserve the right to change specifications or discontinue models without notice.



6 CU. FT. UNDER-COUNTER FREEZER

KCUC27F



Dynamic Condenser improves performance in high temperature environments

Automatic Defrost Cooling System provides worry-free performance

1/3 HP Compressor

Stainless Steel Exterior & Interior

Electronic Control

External Temperature Display

Removable Door Gasket

Adjustable Shelves Vinyl-Coated Steel

Self-Closing Door with 90-degree stay-open feature

Heavy Duty Casters

Reversible Door



Electronic Digital Temperature Control

Quick set digital control and display for easy monitoring.



Stainless Steel Interior

Durable and easy to clean for daily commercial use.



Vinyl Heavy Duty Adjustable Shelves

Shelves that are easy to handle and keep clean.

TECHNICAL SPECIFICATIONS

MODEL	KCUC27F
Product Line	Freezer
Capacity (Cu. Ft.)	6.0
Condenser Type	Dynamic
Automatic Defrost Cooling System	Yes
Compressor Horsepower	1/3
Exterior Finish	Stainless Steel (430)
Interior Finish	Stainless Steel (304)
Shelves (Number/Type)	1/Vinyl-Coated Steel
Control	Electronic
Temperature Display Location	External
Temperature Range	-7 to 10°F
Voltage Rating	115V/60Hz
Run Amps	5.4
Plug Type	NEMA 5-15P
Shipping Weight (Lbs.)	216
Warranty	3 Year/5 Year

kelvinator.com



6 CU. FT. UNDER-COUNTER FREEZER

KCUC27F

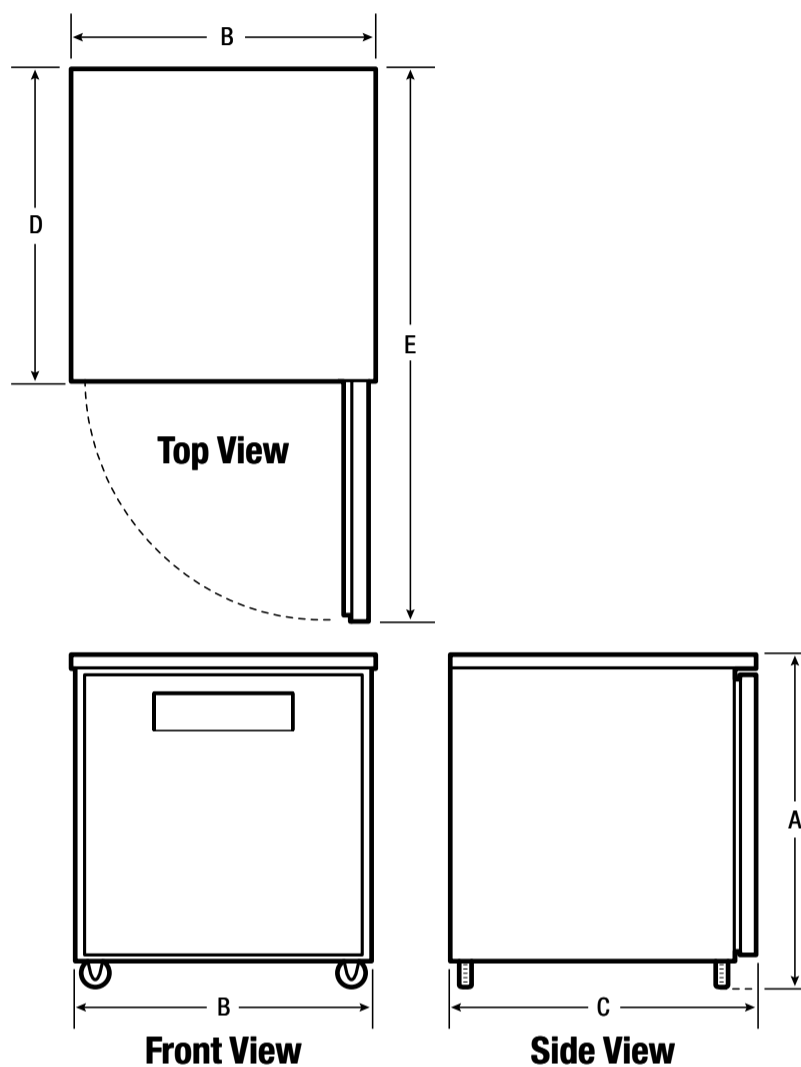

Plug Type (NEMA)
5-15P

EXTERIOR DIMENSIONS

Height A (Including Casters)	35"
Width B	27"
Overall Depth (Including Door & Handle) C	30"
Cabinet Depth D	27-1/16"
Depth (with Door 90° Open) E	54-1/2"

CERTIFICATIONS AND APPROVALS

Safety Certification	ETL
Sanitation Certification	ETL

ACCESSORIES

Shelf	5304486887
Shelf Clip	297121900



USA • 10200 David Taylor Drive • Charlotte, NC 28262 • 1-866-738-1640 • kelvinator.com
CANADA • 5855 Terry Fox Way • Mississauga, ON L5V 3E4

KCUC27F 06/15

© 2015 Electrolux Home Products, Inc.

High standards of quality at Electrolux Home Products, Inc. mean we are constantly working to improve our products. We reserve the right to change specifications or discontinue models without notice.



12 CU. FT. UNDER-COUNTER FREEZER

KCUC48F



Dynamic Condenser improves performance in high temperature environments

Automatic Defrost Cooling System provides worry-free performance

1/2 HP Compressor

Stainless Steel Exterior & Interior

Electronic Control

External Temperature Display

Removable Door Gaskets

Adjustable Shelves Vinyl-Coated Steel

Self-Closing Doors with 90-degree stay-open feature

Heavy Duty Casters



Electronic Digital Temperature Control

Quick set digital control and display for easy monitoring.

Stainless Steel Interior

Durable and easy to clean for daily commercial use.

Vinyl Heavy Duty Adjustable Shelves

Shelves that are easy to handle and keep clean.

TECHNICAL SPECIFICATIONS

MODEL	KCUC48F
Product Line	Freezer
Capacity (Cu. Ft.)	12.0
Condenser Type	Dynamic
Automatic Defrost Cooling System	Yes
Compressor Horsepower	1/2
Exterior Finish	Stainless Steel (430)
Interior Finish	Stainless Steel (304)
Shelves (Number/Type)	2/Vinyl-Coated Steel
Control	Electronic
Temperature Display Location	External
Temperature Range	-7 to 10°F
Voltage Rating	115V/60Hz
Run Amps	8.7
Plug Type	NEMA 5-15P
Shipping Weight (Lbs.)	313
Warranty	3 Year/5 Year

kelvinator.com



12 CU. FT. UNDER-COUNTER FREEZER

KCUC48F

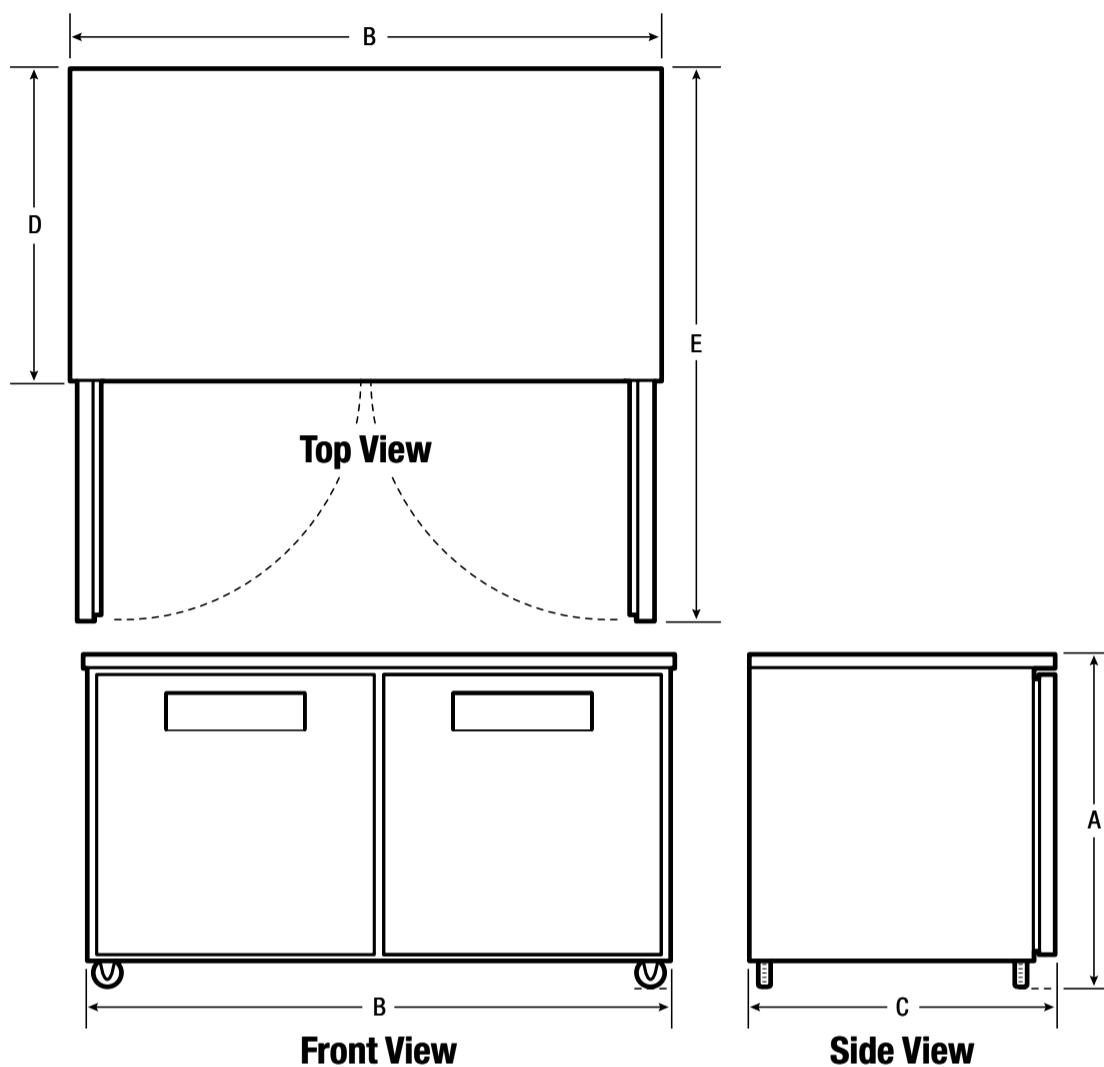

Plug Type (NEMA)
5-15P

EXTERIOR DIMENSIONS

Height A (Including Casters)	35"
Width B	47"
Overall Depth (Including Door & Handle) C	30"
Cabinet Depth D	27-1/16"
Depth (with Door 90° Open) E	54-1/2"

CERTIFICATIONS AND APPROVALS

Safety Certification	ETL
Sanitation Certification	ETL

ACCESSORIES

Shelf	5304486998
Shelf Clip	297121900



USA • 10200 David Taylor Drive • Charlotte, NC 28262 • 1-866-738-1640 • kelvinator.com
CANADA • 5855 Terry Fox Way • Mississauga, ON L5V 3E4

KCUC48F 06/15

© 2015 Electrolux Home Products, Inc.

High standards of quality at Electrolux Home Products, Inc. mean we are constantly working to improve our products. We reserve the right to change specifications or discontinue models without notice.

Kelvinator 



GLASS DOOR
MERCHANDISERS



10 CU. FT. GLASS DOOR MERCHANDISER

KCGM10R

REFRIGERATOR



Dynamic Condenser improves performance in high temperature environments

Automatic Defrost Cooling System provides worry-free performance

1/4 HP Compressor

Painted Steel/Painted Aluminum Exterior & Interior

Mechanical Control

External Temperature Display

Removable Door Gasket

Adjustable Shelves Vinyl-Coated Steel

Self-Closing Swing Door



Electronic Digital Temperature Display

Quick set digital display for easy monitoring.

Vinyl Heavy Duty Adjustable Shelves

Shelves that are easy to handle and keep clean.

Removable Door Gasket

User replaceable door gasket for easy replacement and cleaning.

TECHNICAL SPECIFICATIONS

MODEL	KCGM10R
Product Line	Refrigerator
Door(s)/Type	1 Door Swing
Capacity (Cu. Ft.)	10.0
Condenser Type	Dynamic
Automatic Defrost Cooling System	Yes
Compressor Horsepower	1/4
Exterior Finish	Painted Steel
Interior Finish	Painted Aluminum
Shelves (Number/Type)	4/Vinyl-Coated Steel
Control	Mechanical
Temperature Display Location	External
Temperature Range	32 to 50°F
Voltage Rating	115V/60Hz
Run Amps	3.1
Plug Type	NEMA 5-15P
Shipping Weight (Lbs.)	245
Warranty	3 Year/5 Year



10 CU. FT. GLASS DOOR MERCHANDISER

KCGM10R

REFRIGERATOR

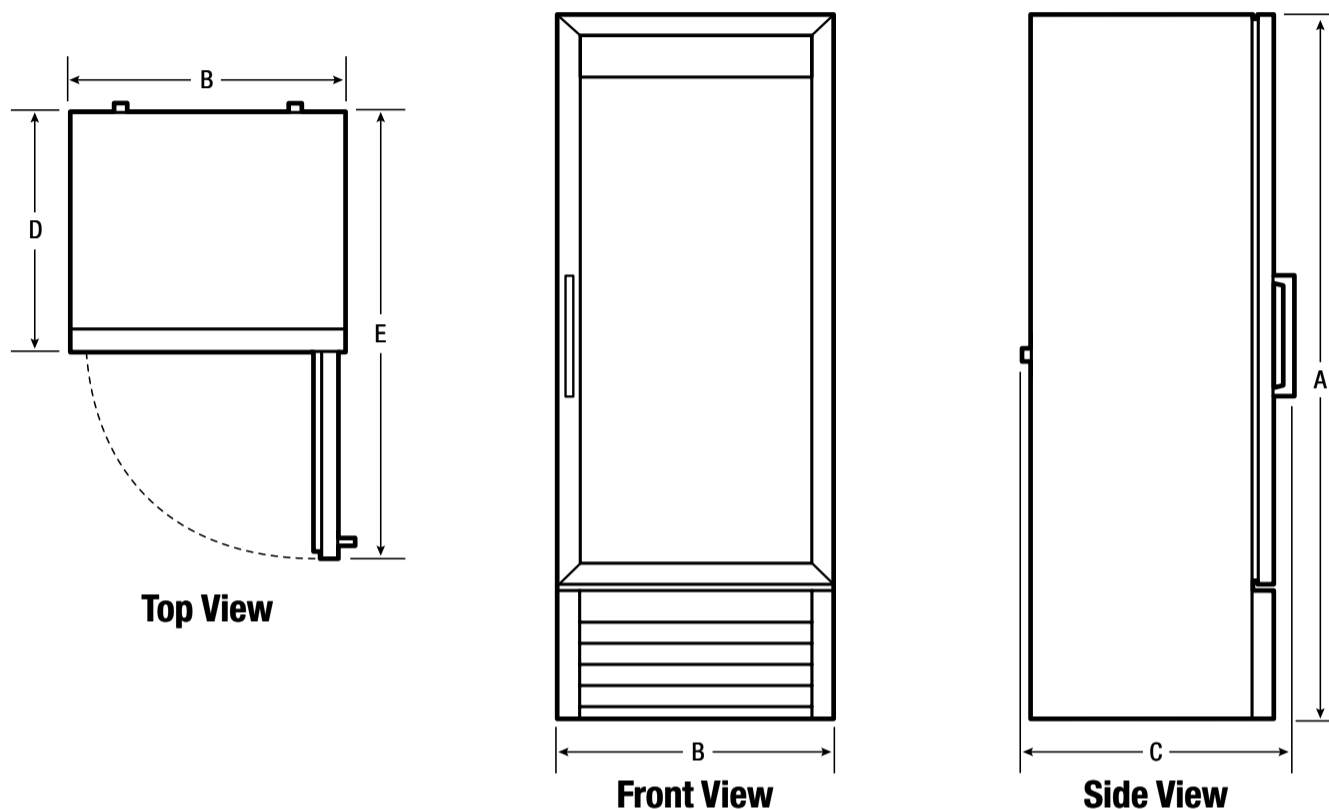

Plug Type (NEMA)
5-15P

EXTERIOR DIMENSIONS

Height A (Including Leveling Legs)	63"
Width B	22"
Overall Depth (Including Door & Handle) C	23"
Cabinet Depth D	19-3/4"
Depth (with Door 90° Open) E	41-1/2"

CERTIFICATIONS AND APPROVALS

Safety Certification	ETL
Sanitation Certification	ETL

ACCESSORIES

Shelf	5304487063
Shelf Clip	297121900



USA • 10200 David Taylor Drive • Charlotte, NC 28262 • 1-866-738-1640 • kelvinator.com
CANADA • 5855 Terry Fox Way • Mississauga, ON L5V 3E4

KCGM10R 06/15

© 2015 Electrolux Home Products, Inc.

High standards of quality at Electrolux Home Products, Inc. mean we are constantly working to improve our products. We reserve the right to change specifications or discontinue models without notice.



18 CU. FT. GLASS DOOR MERCHANDISER

KCGM180RQY

REFRIGERATOR



Dynamic Condenser improves performance in high temperature environments

Automatic Defrost Cooling System provides worry-free performance

1/4 HP Compressor

Painted Steel Exterior & Interior

Mechanical Control

Internal Temperature Display

Adjustable Shelves Vinyl-Coated Steel

Heavy Duty Casters

Interior Lighting



Vinyl Heavy Duty Adjustable Shelves

Shelves that are easy to handle and keep clean.

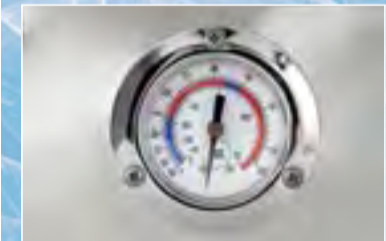

NSF®-Certified Temperature

Durable and reliable for safety in food storage.



Heavy-Duty, Locking Casters

Keeps unit in place but allows position adjusting.

TECHNICAL SPECIFICATIONS

MODEL	KCGM180RQY
Product Line	Refrigerator
Door(s)/Type	1 Door Swing
Capacity (Cu. Ft.)	18
Condenser Type	Dynamic
Automatic Defrost Cooling System	Yes
Compressor Horsepower	1/4
Exterior Finish	Textured Painted Steel
Interior Finish	Smooth Painted Steel
Shelves (Number/Type)	4/Vinyl-Coated Steel
Control	Mechanical
Temperature Display Location	Internal
Temperature Range	32 to 44°F
Voltage Rating	115V/5A
Run Amps	1.3
Plug Type	NEMA 5-15P
Shipping Weight (Lbs.)	275
Warranty	3 Year/5 Year

kelvinator.com



18 CU. FT. GLASS DOOR MERCHANDISER

KCGM180RQY

REFRIGERATOR

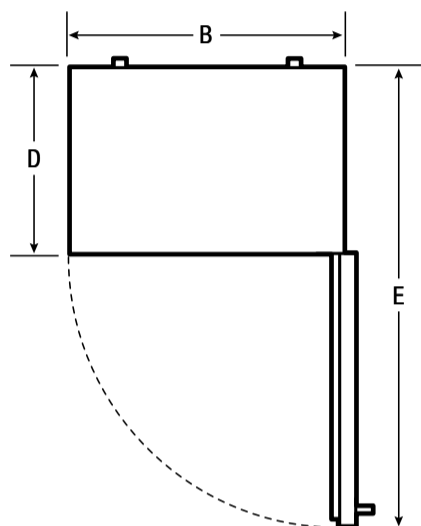

Top View

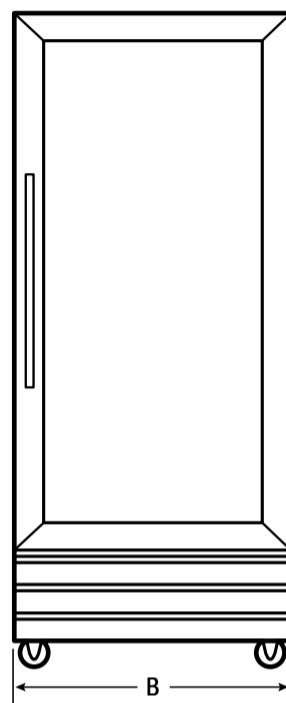

Front View

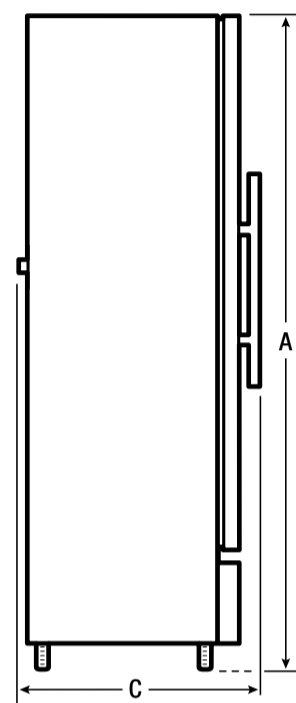

Side View



Plug Type (NEMA)
5-15P

EXTERIOR DIMENSIONS

Height A (Including Casters)	75"
Width B	32"
Overall Depth (Including Door & Handle) C	29-1/2"
Cabinet Depth D	26-1/2"
Depth (with Door 90° Open) E	57"

CERTIFICATIONS AND APPROVALS

ENERGY STAR® Qualified	Yes
Safety Certification	CSA
Sanitation Certification	NSF®

ACCESSORIES

Deep shelf, fits all except top position	216384002
Shelf support clips (Sold as singles, requires 4 per shelf)	297121900
Shallow top shelf (Only fits top position, white finish)	216386202
Trivet (White finish)	216681802



USA • 10200 David Taylor Drive • Charlotte, NC 28262 • 1-866-738-1640 • kelvinator.com
CANADA • 5855 Terry Fox Way • Mississauga, ON L5V 3E4

KCGM180RQ 06/15

© 2015 Electrolux Home Products, Inc.

High standards of quality at Electrolux Home Products, Inc. mean we are constantly working to improve our products. We reserve the right to change specifications or discontinue models without notice.

24 CU. FT. GLASS DOOR MERCHANDISER

KCGM24R

REFRIGERATOR



Dynamic Condenser improves performance in high temperature environments

Automatic Defrost Cooling System provides worry-free performance

1/3 HP Compressor

Painted Steel/Painted Aluminum Exterior & Interior

Mechanical Control

External Temperature Display

Removable Door Gasket

Adjustable Shelves Vinyl-Coated Steel

Self-Closing Swing Door



Electronic Digital Temperature Display

Quick set digital display for easy monitoring.

Vinyl Heavy Duty Adjustable Shelves

Shelves that are easy to handle and keep clean.

Removable Door Gasket

User replaceable door gasket for easy replacement and cleaning.

TECHNICAL SPECIFICATIONS

MODEL	KCGM24R
Product Line	Refrigerator
Door(s)/Type	1 Door Swing
Capacity (Cu. Ft.)	24.0
Condenser Type	Dynamic
Automatic Defrost Cooling System	Yes
Compressor Horsepower	1/3
Exterior Finish	Painted Steel
Interior Finish	Painted Aluminum
Shelves (Number/Type)	4/Vinyl-Coated Steel
Control	Mechanical
Temperature Display Location	External
Temperature Range	32 to 50°F
Voltage Rating	115V/60Hz
Run Amps	8.6
Plug Type	NEMA 5-15P
Shipping Weight (Lbs.)	363
Warranty	3 Year/5 Year



24 CU. FT. GLASS DOOR MERCHANDISER

KCGM24R

REFRIGERATOR

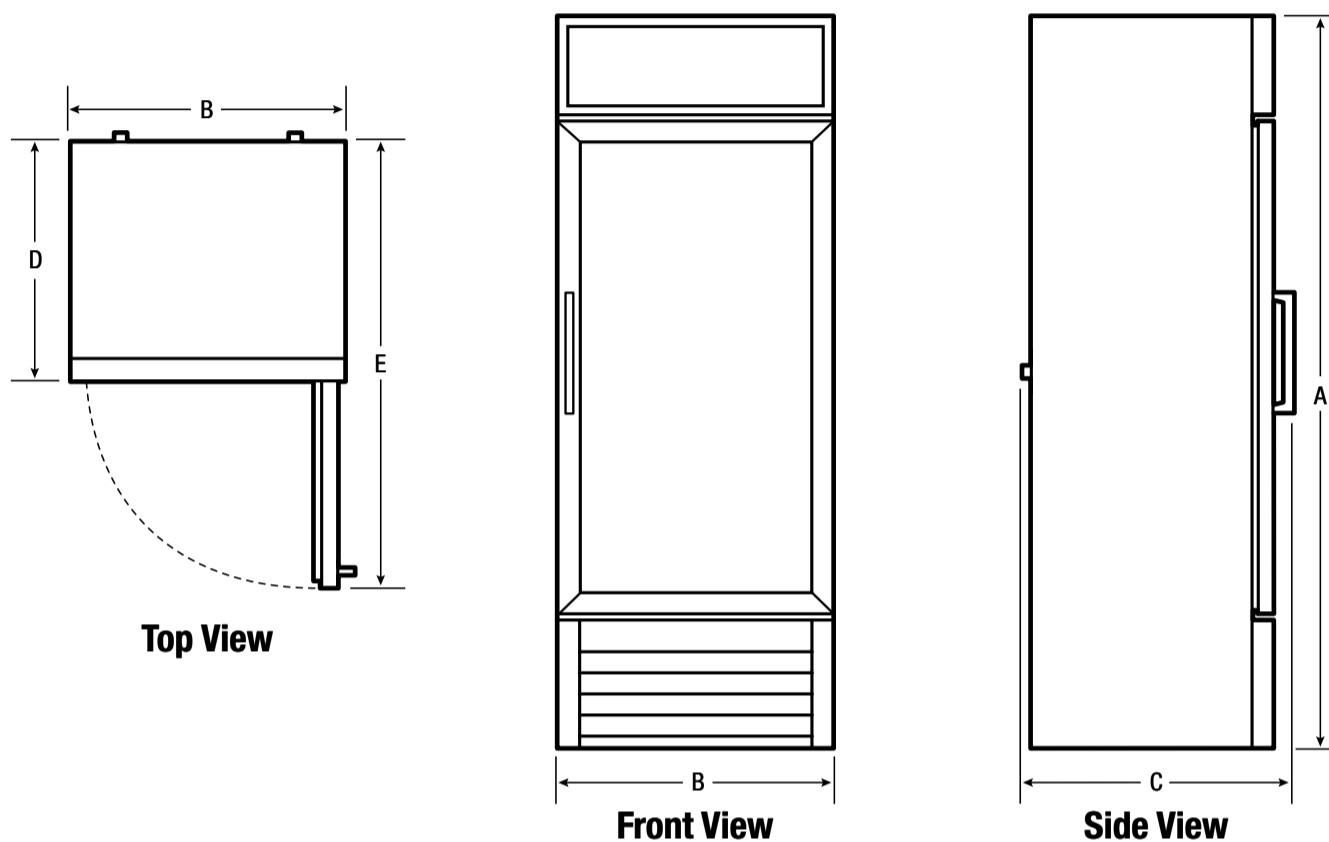

Plug Type (NEMA)
5-15P

EXTERIOR DIMENSIONS

Height A (Including Leveling Legs)	79"
Width B	28"
Overall Depth (Including Door & Handle) C	33-5/16"
Cabinet Depth D	31-5/16"
Depth (with Door 90° Open) E	58-1/2"

CERTIFICATIONS AND APPROVALS

Safety Certification	ETL
Sanitation Certification	ETL

ACCESSORIES

Shelf	5304487114
Shelf Clip	297121900



USA • 10200 David Taylor Drive • Charlotte, NC 28262 • 1-866-738-1640 • kelvinator.com
CANADA • 5855 Terry Fox Way • Mississauga, ON L5V 3E4

KCGM24R 06/15

© 2015 Electrolux Home Products, Inc.

High standards of quality at Electrolux Home Products, Inc. mean we are constantly working to improve our products. We reserve the right to change specifications or discontinue models without notice.



47 CU. FT. GLASS DOOR MERCHANDISER

KCGM47R

REFRIGERATOR



Dynamic Condenser improves performance in high temperature environments

Automatic Defrost Cooling System provides worry-free performance

1/2 HP Compressor

Painted Steel/Painted Aluminum Exterior & Interior

Mechanical Control

External Temperature Display

Adjustable Shelves Vinyl-Coated Steel

Self-Closing Sliding Doors

Heavy Duty Casters

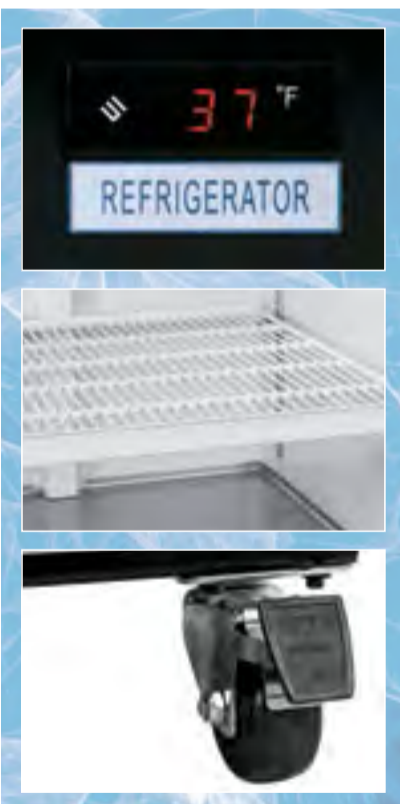

Electronic Digital Temperature Display

Quick set digital display for easy monitoring.

Vinyl Heavy Duty Adjustable Shelves

Shelves that are easy to handle and keep clean.

Heavy-Duty, Locking Casters

Keeps unit in place but allows position adjusting.

TECHNICAL SPECIFICATIONS

MODEL	KCGM47R
Product Line	Refrigerator
Door(s)/Type	2 Door Slide
Capacity (Cu. Ft.)	47.0
Condenser Type	Dynamic
Automatic Defrost Cooling System	Yes
Compressor Horsepower	1/2
Exterior Finish	Painted Steel
Interior Finish	Painted Aluminum
Shelves (Number/Type)	8/Vinyl-Coated Steel
Control	Mechanical
Temperature Display Location	External
Temperature Range	32 to 50°F
Voltage Rating	115V/60Hz
Run Amps	9.2
Plug Type	NEMA 5-15P
Shipping Weight (Lbs.)	486
Warranty	3 Year/5 Year

kelvinator.com



47 CU. FT. GLASS DOOR MERCHANDISER

KCGM47R

REFRIGERATOR

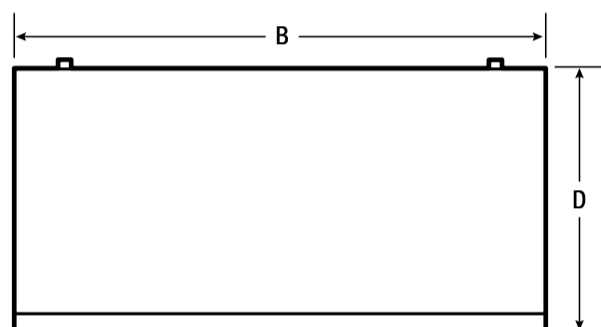

Top View

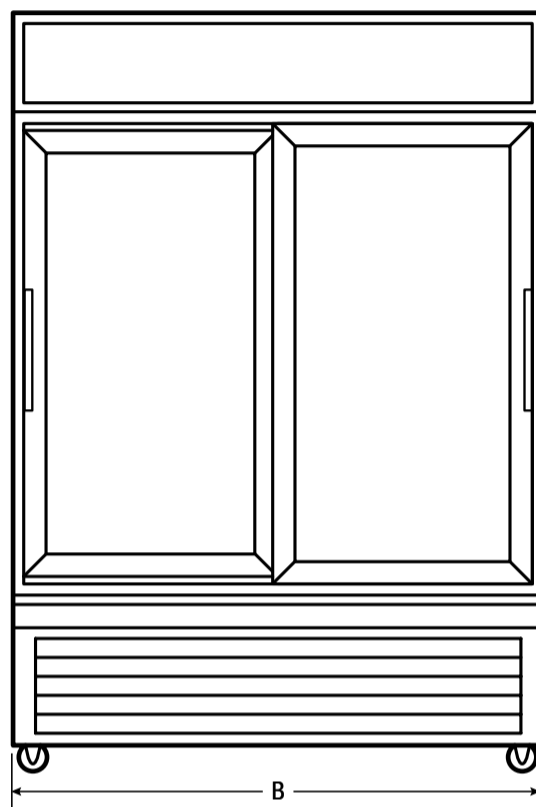

Front View

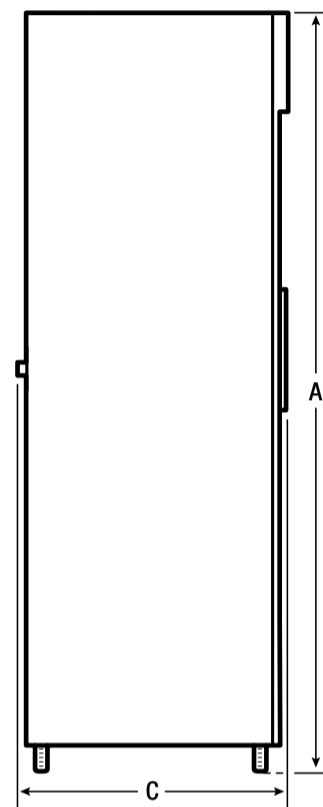

Side View



Plug Type (NEMA)
5-15P

EXTERIOR DIMENSIONS

Height A (Including Casters)	83"
Width B	53"
Overall Depth (Including Door & Handle) C	30-11/16"
Cabinet Depth D	30-1/2"

CERTIFICATIONS AND APPROVALS

Safety Certification	ETL
Sanitation Certification	ETL

ACCESSORIES

Shelf	5304487245
Shelf Clip	297121900

Kelvinator

USA • 10200 David Taylor Drive • Charlotte, NC 28262 • 1-866-738-1640 • kelvinator.com

CANADA • 5855 Terry Fox Way • Mississauga, ON L5V 3E4

KCGM47R 06/15

© 2015 Electrolux Home Products, Inc.

High standards of quality at Electrolux Home Products, Inc. mean we are constantly working to improve our products. We reserve the right to change specifications or discontinue models without notice.



9 CU. FT. GLASS DOOR MERCHANDISER

KCGM9F

FREEZER



Dynamic Condenser improves performance in high temperature environments

Automatic Defrost Cooling System provides worry-free performance

7/8 HP Compressor

Painted Steel/Painted Aluminum Exterior & Interior

Electronic Control

External Temperature Display

Removable Door Gasket

Adjustable Shelves Vinyl-Coated Steel

Self-Closing Swing Door



Electronic Digital Temperature Control

Quick set digital control and display for easy monitoring.



Vinyl Heavy Duty Adjustable Shelves

Shelves that are easy to handle and keep clean.



Removable Door Gasket

User replaceable door gasket for easy replacement and cleaning.

TECHNICAL SPECIFICATIONS

MODEL	KCGM9F
Product Line	Freezer
Door(s)/Type	1 Door Swing
Capacity (Cu. Ft.)	9.0
Condenser Type	Dynamic
Automatic Defrost Cooling System	Yes
Compressor Horsepower	7/8
Exterior Finish	Painted Steel
Interior Finish	Painted Aluminum
Shelves (Number/Type)	2/Vinyl-Coated Steel
Control	Electronic
Temperature Display Location	External
Temperature Range	-7 to 10°F
Voltage Rating	115V/60Hz
Run Amps	5.2
Plug Type	NEMA 5-15P
Shipping Weight (Lbs.)	251
Warranty	3 Year/5 Year

kelvinator.com



9 CU. FT. GLASS DOOR MERCHANDISER

KCGM9F

FREEZER

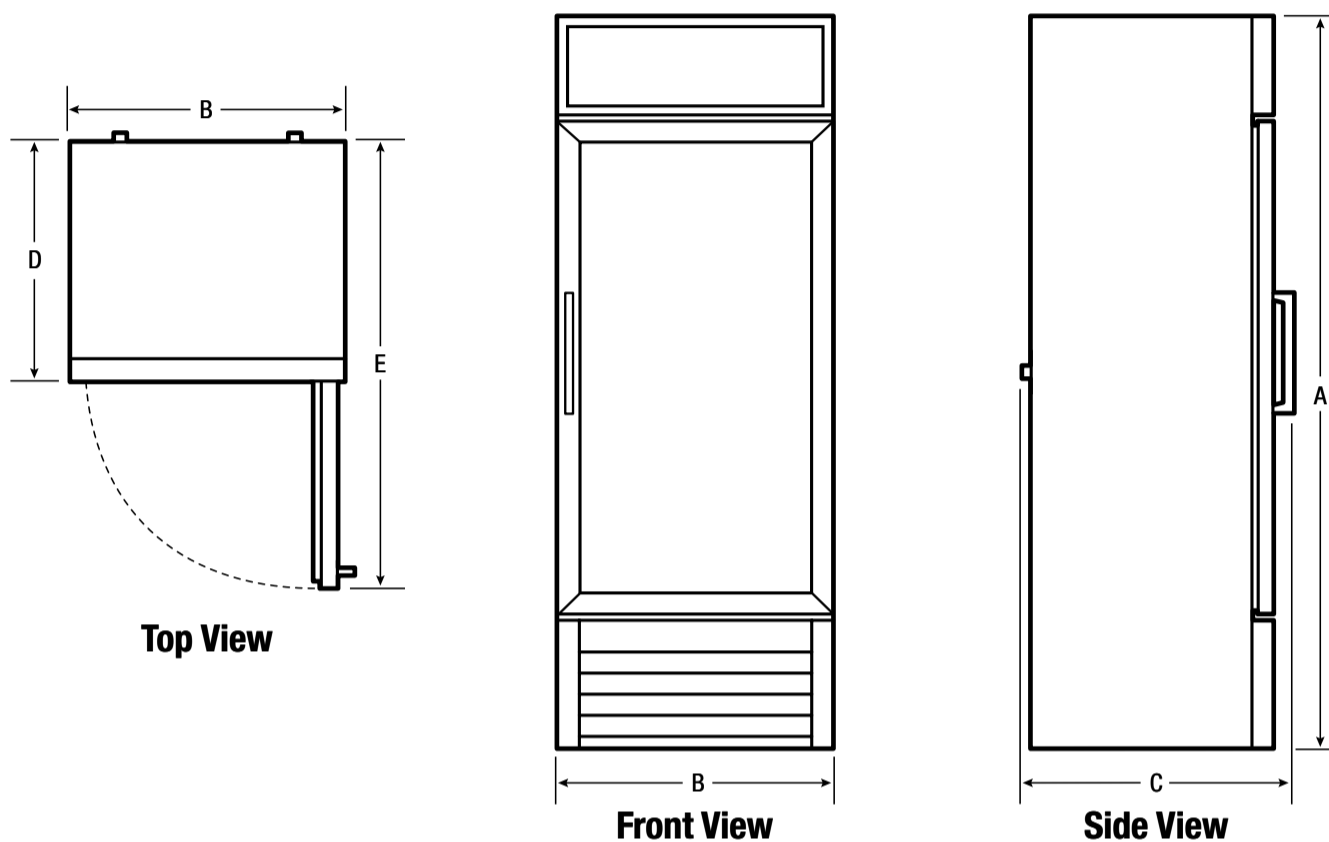

Plug Type (NEMA)
5-15P

EXTERIOR DIMENSIONS

Height A (Including Leveling Legs)	59"
Width B	27"
Overall Depth (Including Door & Handle) C	27-1/4"
Cabinet Depth D	24-1/16"
Depth (with Door 90° Open) E	51"

CERTIFICATIONS AND APPROVALS

Safety Certification	ETL
Sanitation Certification	ETL

ACCESSORIES

Shelf	5304487262
Shelf Clip	297121900



USA • 10200 David Taylor Drive • Charlotte, NC 28262 • 1-866-738-1640 • kelvinator.com
CANADA • 5855 Terry Fox Way • Mississauga, ON L5V 3E4

KCGM9F 06/15

© 2015 Electrolux Home Products, Inc.

High standards of quality at Electrolux Home Products, Inc. mean we are constantly working to improve our products. We reserve the right to change specifications or discontinue models without notice.



24 CU. FT. GLASS DOOR MERCHANDISER

KCGM24FB

FREEZER



Fin & Tube Condenser improves performance in high temperature environments

Automatic Defrost Cooling System provides worry-free performance

1 HP Compressor

Painted Steel/Painted Aluminum Exterior & Interior

Electronic Controls

External Temperature Display

Removable Door Gasket

Adjustable Shelves Vinyl-Coated Steel

Self-Closing Swing Door



Electronic Digital Temperature Display

Quick set digital display for easy monitoring.



Vinyl Heavy Duty Adjustable Shelves

Shelves that are easy to handle and keep clean.



Removable Door Gasket

User replaceable door gasket for easy replacement and cleaning.

TECHNICAL SPECIFICATIONS

MODEL	KCGM24FB
Product Line	Freezer
Door(s)/Type	1 Door Swing
Capacity (Cu. Ft.)	24.0
Condenser Type	Fin & Tube
Automatic Defrost Cooling System	Yes
Compressor Horsepower	1
Exterior Finish	Painted Steel
Interior Finish	Painted Aluminum
Shelves (Number/Type)	4/Vinyl-Coated Steel
Control	Electronic
Temperature Display Location	External
Temperature Range	-7 to 10°F
Voltage Rating	115V/60Hz
Run Amps	9.6
Plug Type	NEMA 5-20P
Shipping Weight (Lbs.)	407
Warranty	3 Year/5 Year

kelvinator.com



24 CU. FT. GLASS DOOR MERCHANDISER

KCGM24FB

FREEZER

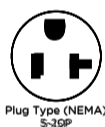
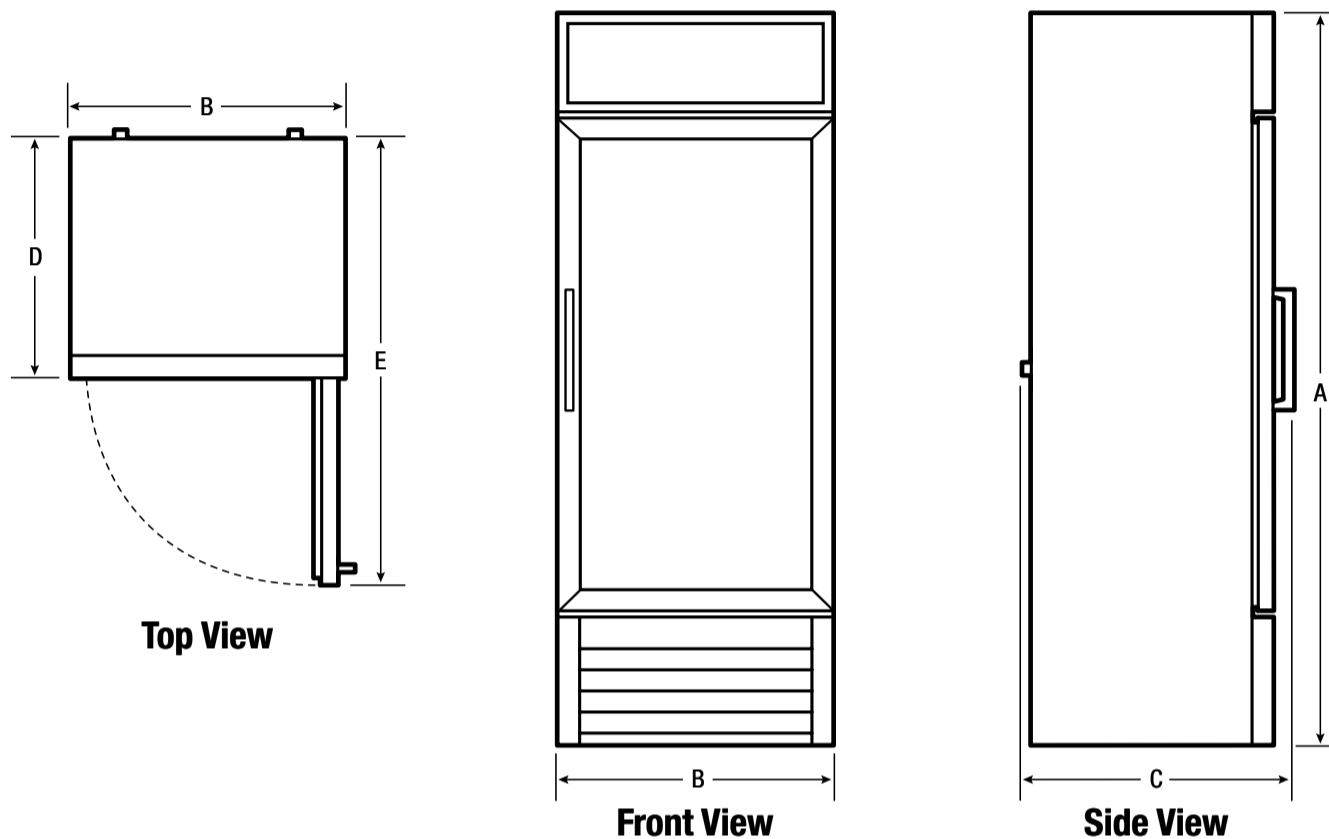

EXTERIOR DIMENSIONS

Height A (Including Leveling Legs)	83"
Width B	28"
Overall Depth (Including Door & Handle) C	32"
Cabinet Depth D	30"
Depth (with Door 90° Open) E	58-1/2"

CERTIFICATIONS AND APPROVALS

Safety Certification	ETL
Sanitation Certification	ETL

ACCESSORIES

Shelf	5304493131
Shelf Clip	297121900



USA • 10200 David Taylor Drive • Charlotte, NC 28262 • 1-866-738-1640 • kelvinator.com
 CANADA • 5855 Terry Fox Way • Mississauga, ON L5V 3E4

KCGM24F 06/15

© 2015 Electrolux Home Products, Inc.

High standards of quality at Electrolux Home Products, Inc. mean we are constantly working to improve our products. We reserve the right to change specifications or discontinue models without notice.



27 CU. FT. GLASS DOOR MERCHANDISER

KCGM27F

FREEZER



Dynamic Condenser improves performance in high temperature environments

Automatic Defrost Cooling System provides worry-free performance

1-1/3 HP Compressor

Painted Steel/Painted Aluminum Exterior & Interior

Electronic Controls

External Temperature Display

Removable Door Gaskets

Adjustable Shelves Vinyl-Coated Steel

Self-Closing Swing Doors

Heavy Duty Casters



TECHNICAL SPECIFICATIONS

MODEL	KCGM27F
Product Line	Freezer
Door(s)/Type	2 Door Swing
Capacity (Cu. Ft.)	27.0
Condenser Type	Dynamic
Automatic Defrost Cooling System	Yes
Compressor Horsepower	1-1/3
Exterior Finish	Painted Steel
Interior Finish	Painted Aluminum
Shelves (Number/Type)	8/Vinyl-Coated Steel
Control	Electronic
Temperature Display Location	External
Temperature Range	-7 to 10°F
Voltage Rating	115V/60Hz
Run Amps	9.6
Plug Type	NEMA 5-20P
Shipping Weight (Lbs.)	442
Warranty	3 Year/5 Year

Electronic Digital Temperature Control

Quick set digital control and display for easy monitoring.



Vinyl Heavy Duty Adjustable Shelves

Shelves that are easy to handle and keep clean.



Removable Door Gaskets

User replaceable door gaskets for easy replacement and cleaning.



kelvinator.com



27 CU. FT. GLASS DOOR MERCHANDISER

KCGM27F

FREEZER

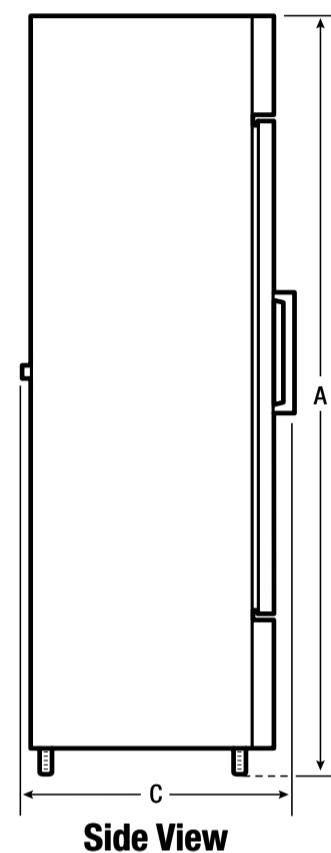
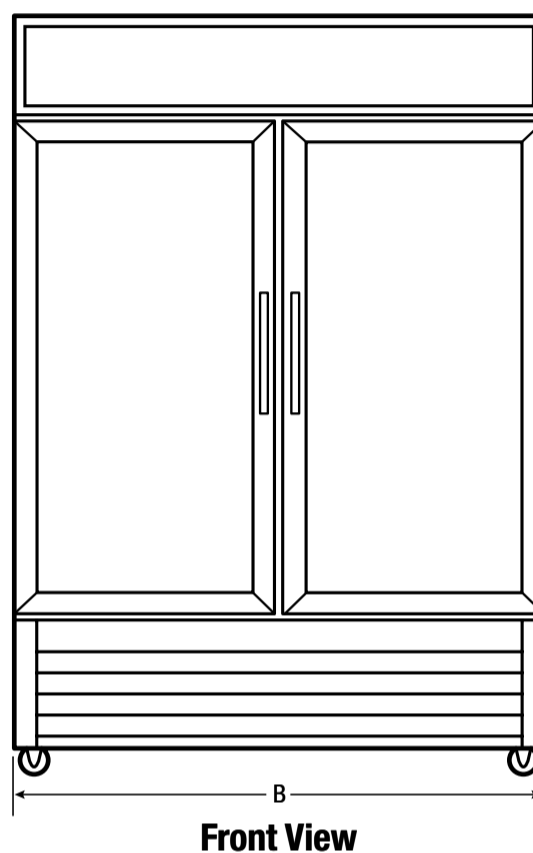
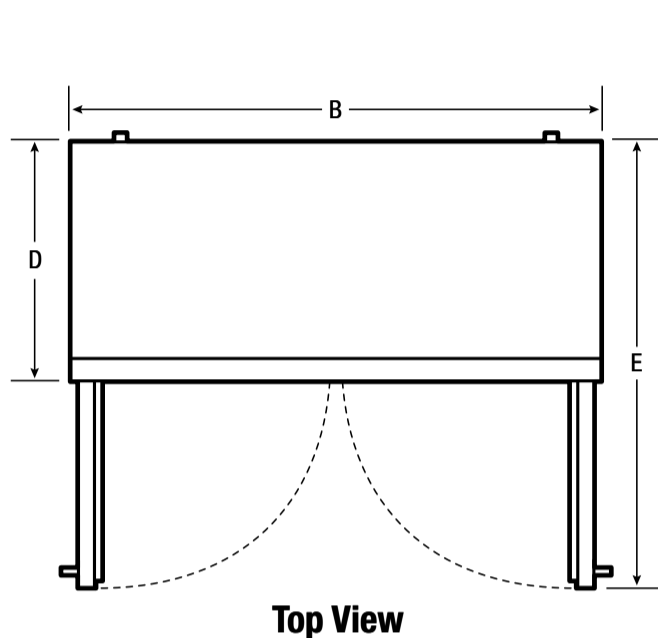

Plug Type (NEMA)
5-15P

EXTERIOR DIMENSIONS

Height A (Including Casters)	80"
Width B	49"
Overall Depth (Including Door & Handle) C	28"
Cabinet Depth D	26"
Depth (with Door 90° Open) E	49"

CERTIFICATIONS AND APPROVALS

Safety Certification	ETL
Sanitation Certification	ETL

ACCESSORIES

Shelf	5304487387
Shelf Clip	297121900



USA • 10200 David Taylor Drive • Charlotte, NC 28262 • 1-866-738-1640 • kelvinator.com
CANADA • 5855 Terry Fox Way • Mississauga, ON L5V 3E4

KCGM27F 06/15

© 2015 Electrolux Home Products, Inc.

High standards of quality at Electrolux Home Products, Inc. mean we are constantly working to improve our products. We reserve the right to change specifications or discontinue models without notice.

Kelvinator 



BAR
EQUIPMENT



11.8 CU. FT. BACK BAR REFRIGERATOR

KCBB48SB



Fin & Tube Condenser improves performance in high temperature environments

Automatic Defrost Cooling System provides worry-free performance

1/3 HP Compressor

**Painted Steel Exterior/
Stainless Steel Interior**

Mechanical Control

Adjustable Shelves Vinyl-Coated Steel

Stay-Open Self-Closing Doors

Locking Doors & Key protect the contents of the unit



Mechanical Control

Select temperatures as required.



Locking Doors

Secure the inventory.



Heavy Duty Adjustable Shelves

Shelves that are easy to handle and keep clean.

TECHNICAL SPECIFICATIONS

MODEL	KCBB48SB
Product Line	Refrigerator
Capacity (Cu. Ft.)	11.8
Condenser Type	Fin & Tube
Automatic Defrost Cooling System	Yes
Compressor Horsepower	1/3
Exterior Finish	Painted Steel
Interior Finish	Stainless Steel (304)
Shelves (Number/Type)	4/Vinyl-Coated Steel
Control	Mechanical
Temperature Display Location	External
Temperature Range	32 to 38°F
Voltage Rating	115V/60Hz
Run Amps	6.4
Plug Type	NEMA 5-15P
Shipping Weight (Lbs.)	350
Warranty	3 Year/5 Year



11.8 CU. FT. BACK BAR REFRIGERATOR

KCBB48SB

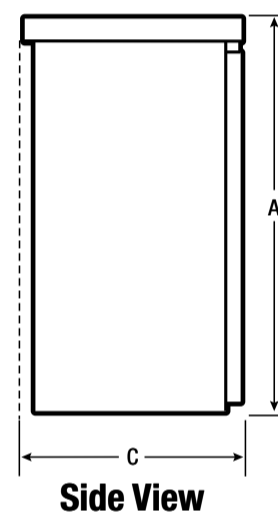
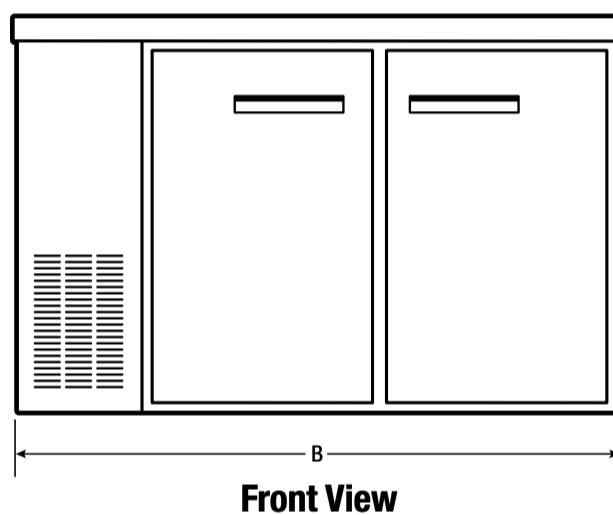
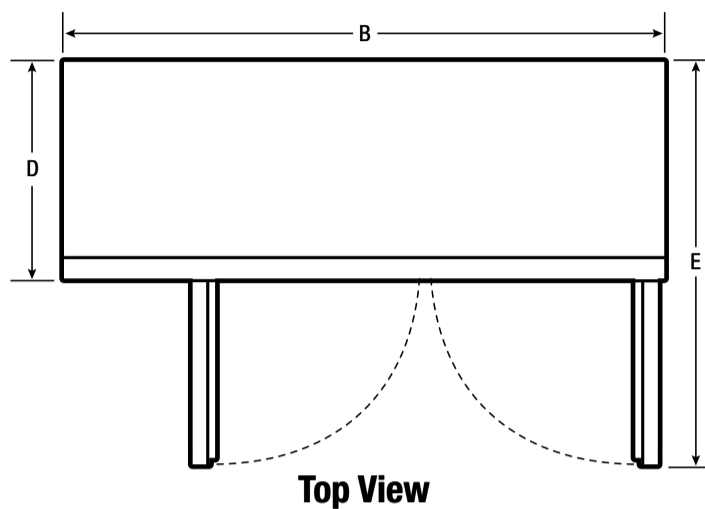

Plug Type (NEMA)
5-15P

EXTERIOR DIMENSIONS

Height A	36"
Width B	48-3/4"
Overall Depth (Including Door & Handle) C	24-1/2"
Cabinet Depth D	24-1/2"
Depth (with Door 90° Open) E	42"

CERTIFICATIONS AND APPROVALS

Safety Certification	ETL
Sanitation Certification	ETL

ACCESSORIES

Shelf	5304497341
Shelf Clip	297121900



USA • 10200 David Taylor Drive • Charlotte, NC 28262 • 1-866-738-1640 • kelvinator.com
CANADA • 5855 Terry Fox Way • Mississauga, ON L5V 3E4

KCBB48S 06/15

© 2015 Electrolux Home Products, Inc.

High standards of quality at Electrolux Home Products, Inc. mean we are constantly working to improve our products. We reserve the right to change specifications or discontinue models without notice.



15.8 CU. FT. BACK BAR REFRIGERATOR

KCBB60SB



Fin & Tube Condenser improves performance in high temperature environments

Automatic Defrost Cooling System provides worry-free performance

1/3 HP Compressor

**Painted Steel Exterior/
Stainless Steel Interior**

Mechanical Control

Adjustable Shelves Vinyl-Coated Steel

Stay-Open Self-Closing Doors

Locking Doors & Key protect the contents of the unit



Mechanical Control

Select temperatures as required.

Locking Doors

Secure the inventory.

Heavy Duty Adjustable Shelves

Shelves that are easy to handle and keep clean.

TECHNICAL SPECIFICATIONS

MODEL	KCBB60SB
Product Line	Refrigerator
Capacity (Cu. Ft.)	15.8
Condenser Type	Fin & Tube
Automatic Defrost Cooling System	Yes
Compressor Horsepower	1/3
Exterior Finish	Painted Steel
Interior Finish	Stainless Steel (304)
Shelves (Number/Type)	4/Vinyl-Coated Steel
Control	Mechanical
Temperature Display Location	External
Temperature Range	32 to 38°F
Voltage Rating	115V/60Hz
Run Amps	6.4
Plug Type	NEMA 5-15P
Shipping Weight (Lbs.)	380
Warranty	3 Year/5 Year

kelvinator.com



15.8 CU. FT. BACK BAR REFRIGERATOR

KCBB60SB

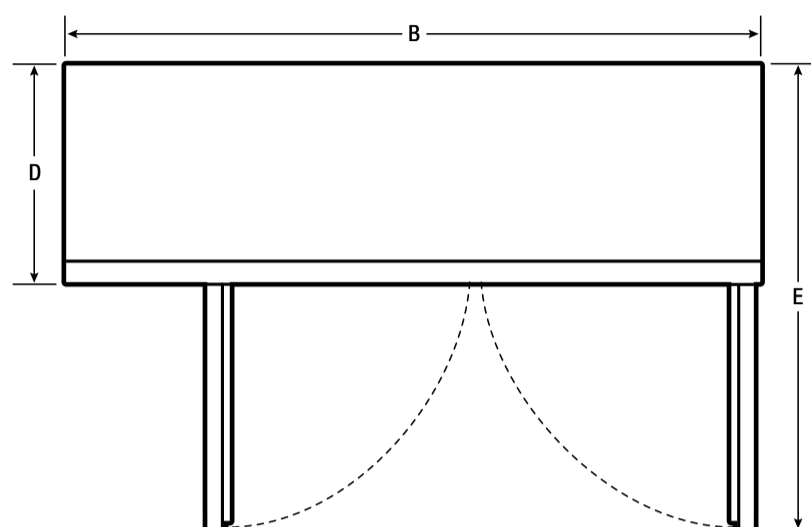

Top View

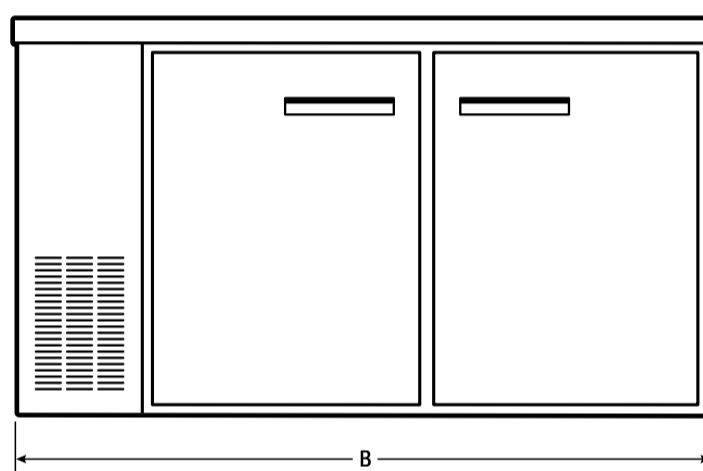

Front View

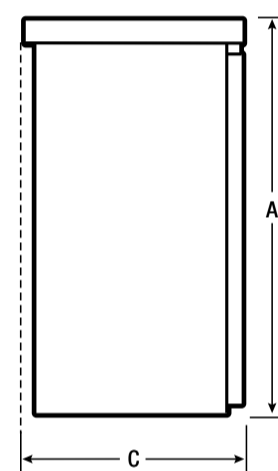

Side View



Plug Type (NEMA)
5-15P

EXTERIOR DIMENSIONS

Height A	36"
Width B	60-7/8"
Overall Depth (Including Door & Handle) C	24-1/2"
Cabinet Depth D	24-1/2"
Depth (with Door 90° Open) E	47-1/2"

CERTIFICATIONS AND APPROVALS

Safety Certification	ETL
Sanitation Certification	ETL

ACCESSORIES

Shelf	5304497342
Shelf Clip	297121900

Kelvinator

USA • 10200 David Taylor Drive • Charlotte, NC 28262 • 1-866-738-1640 • kelvinator.com

CANADA • 5855 Terry Fox Way • Mississauga, ON L5V 3E4

KCBB60S 06/15

© 2015 Electrolux Home Products, Inc.

High standards of quality at Electrolux Home Products, Inc. mean we are constantly working to improve our products. We reserve the right to change specifications or discontinue models without notice.



19.6 CU. FT. BACK BAR REFRIGERATOR

KCBB72SB



Fin & Tube Condenser improves performance in high temperature environments

Automatic Defrost Cooling System provides worry-free performance

1/3 HP Compressor

**Painted Steel Exterior/
Stainless Steel Interior**

Mechanical Control

Adjustable Shelves Vinyl-Coated Steel

Stay-Open Self-Closing Doors

Locking Doors & Key protect the contents of the unit



Mechanical Control

Select temperatures as required.

Locking Doors

Secure the inventory.

Heavy Duty Adjustable Shelves

Shelves that are easy to handle and keep clean.

TECHNICAL SPECIFICATIONS

MODEL	KCBB72SB
Product Line	Refrigerator
Capacity (Cu. Ft.)	19.6
Condenser Type	Fin & Tube
Automatic Defrost Cooling System	Yes
Compressor Horsepower	1/3
Exterior Finish	Painted Steel
Interior Finish	Stainless Steel (304)
Shelves (Number/Type)	6/Vinyl-Coated Steel
Control	Mechanical
Temperature Display Location	External
Temperature Range	32 to 38°F
Voltage Rating	115V/60Hz
Run Amps	6.4
Plug Type	NEMA 5-15P
Shipping Weight (Lbs.)	410
Warranty	3 Year/5 Year

kelvinator.com



19.6 CU. FT. BACK BAR REFRIGERATOR

KCBB72SB

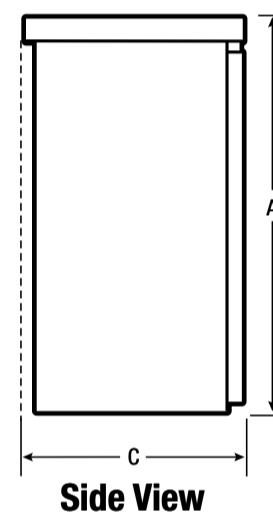
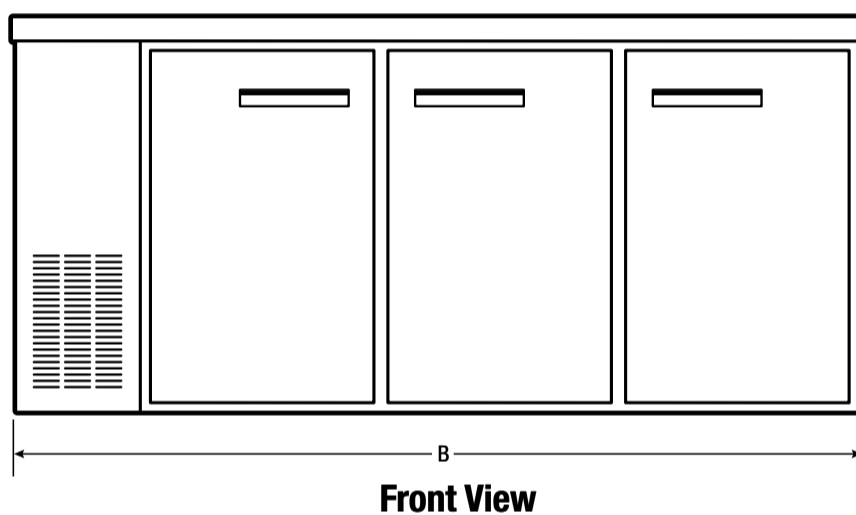
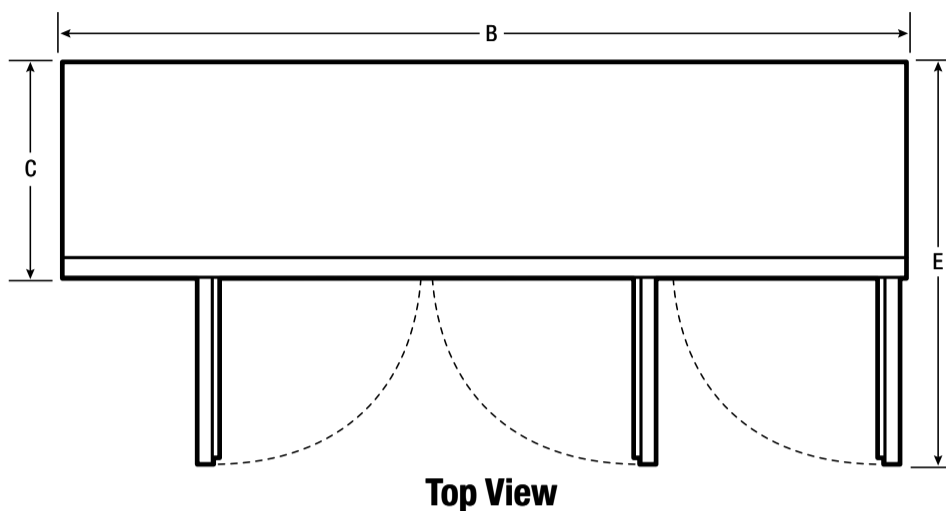

Plug Type (NEMA)
5-15P

EXTERIOR DIMENSIONS

Height A	36"
Width B	72-7/8"
Overall Depth (Including Door & Handle) C	24-1/2"
Cabinet Depth D	24-1/2"
Depth (with Door 90° Open) E	43"

CERTIFICATIONS AND APPROVALS

Safety Certification	ETL
Sanitation Certification	ETL

ACCESSORIES

Shelf	5304497343
Shelf Clip	297121900



USA • 10200 David Taylor Drive • Charlotte, NC 28262 • 1-866-738-1640 • kelvinator.com
CANADA • 5855 Terry Fox Way • Mississauga, ON L5V 3E4

KCBB72S 06/15

© 2015 Electrolux Home Products, Inc.

High standards of quality at Electrolux Home Products, Inc. mean we are constantly working to improve our products. We reserve the right to change specifications or discontinue models without notice.



11.8 CU. FT. BACK BAR REFRIGERATOR

KCBB48GB



Fin & Tube Condenser improves performance in high temperature environments

Automatic Defrost Cooling System provides worry-free performance

1/3 HP Compressor

**Painted Steel Exterior/
Stainless Steel Interior**

Mechanical Control

Adjustable Shelves Vinyl-Coated Steel

Stay-Open Self-Closing Doors

Locking Doors & Key protect the contents of the unit



Mechanical Control

Select temperatures as required.

Locking Doors

Secure the inventory.

Heavy Duty Adjustable Shelves

Shelves that are easy to handle and keep clean.

TECHNICAL SPECIFICATIONS

MODEL	KCBB48GB
Product Line	Refrigerator
Door(s)/Type	2 Door Swing
Capacity (Cu. Ft.)	11.8
Condenser Type	Fin & Tube
Automatic Defrost Cooling System	Yes
Compressor Horsepower	1/3
Exterior Finish	Painted Steel
Interior Finish	Stainless Steel (304)
Shelves (Number/Type)	4/Vinyl-Coated Steel
Control	Mechanical
Temperature Display Location	External
Temperature Range	32 to 38°F
Voltage Rating	115V/60Hz
Run Amps	6.4
Plug Type	NEMA 5-15P
Shipping Weight (Lbs.)	350
Warranty	3 Year/5 Year

kelvinator.com



11.8 CU. FT. BACK BAR REFRIGERATOR

KCBB48GB

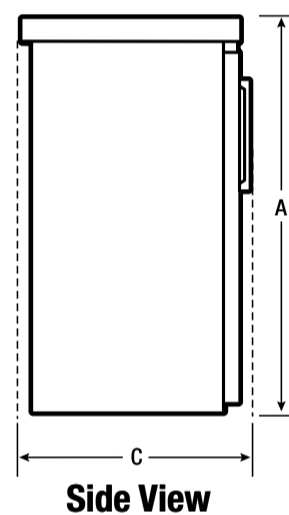
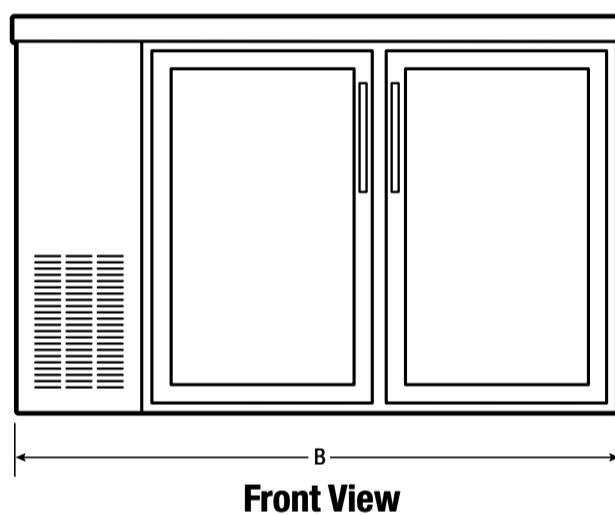
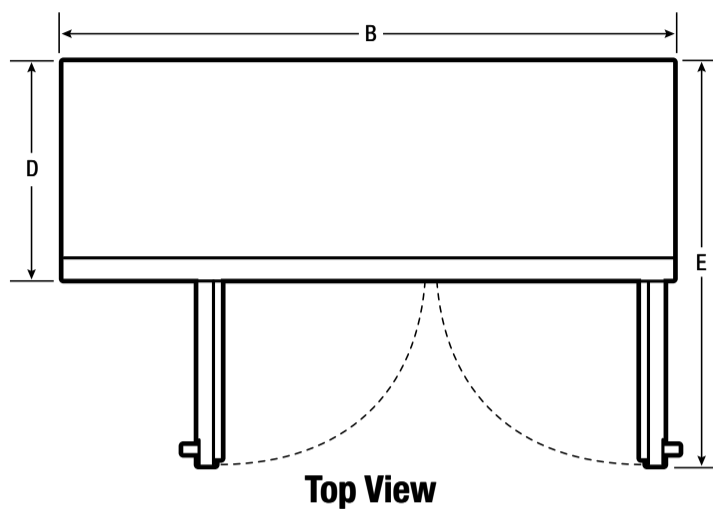

Plug Type (NEMA)
5-15P

EXTERIOR DIMENSIONS

Height A	36"
Width B	48-7/8"
Overall Depth (Including Door & Handle) C	24-1/2"
Cabinet Depth D	24-1/2"
Depth (with Door 90° Open) E	42"

CERTIFICATIONS AND APPROVALS

Safety Certification	ETL
Sanitation Certification	ETL

ACCESSORIES

Shelf	5304497341
Shelf Clip	297121900



USA • 10200 David Taylor Drive • Charlotte, NC 28262 • 1-866-738-1640 • kelvinator.com
CANADA • 5855 Terry Fox Way • Mississauga, ON L5V 3E4

KCBB48G 06/15

© 2015 Electrolux Home Products, Inc.

High standards of quality at Electrolux Home Products, Inc. mean we are constantly working to improve our products. We reserve the right to change specifications or discontinue models without notice.



15.8 CU. FT. BACK BAR REFRIGERATOR

KCBB60GB



Fin & Tube Condenser improves performance in high temperature environments

Automatic Defrost Cooling System provides worry-free performance

1/3 HP Compressor

**Painted Steel Exterior/
Stainless Steel Interior**

Mechanical Control

Adjustable Shelves Vinyl-Coated Steel

Stay-Open Self-Closing Doors

Locking Doors & Key protect the contents of the unit



Mechanical Control

Select temperatures as required.

Locking Doors

Secure the inventory.

Heavy Duty Adjustable Shelves

Shelves that are easy to handle and keep clean.

TECHNICAL SPECIFICATIONS

MODEL	KCBB60GB
Product Line	Refrigerator
Door(s)/Type	2 Door Swing
Capacity (Cu. Ft.)	15.8
Condenser Type	Fin & Tube
Automatic Defrost Cooling System	Yes
Compressor Horsepower	1/3
Exterior Finish	Painted Steel
Interior Finish	Stainless Steel (304)
Shelves (Number/Type)	4/Vinyl-Coated Steel
Control	Mechanical
Temperature Display Location	External
Temperature Range	32 to 38°F
Voltage Rating	115V/60Hz
Run Amps	6.4
Plug Type	NEMA 5-15P
Shipping Weight (Lbs.)	380
Warranty	3 Year/5 Year

kelvinator.com



15.8 CU. FT. BACK BAR REFRIGERATOR

KCBB60GB

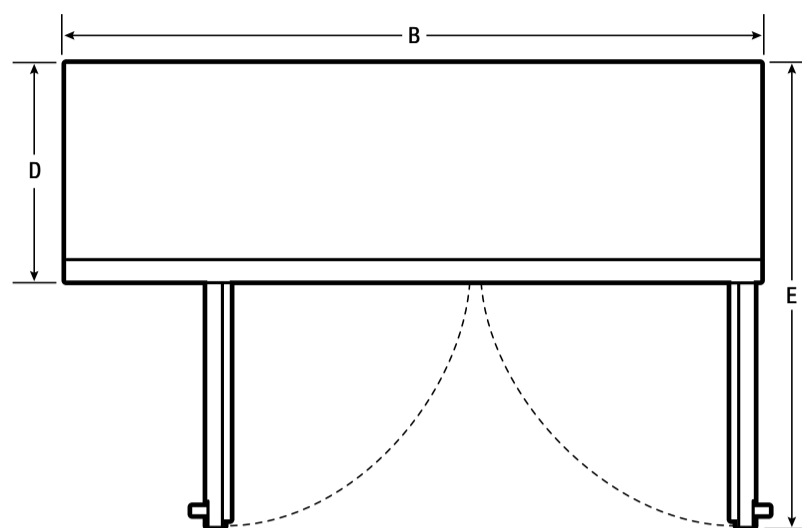

Top View

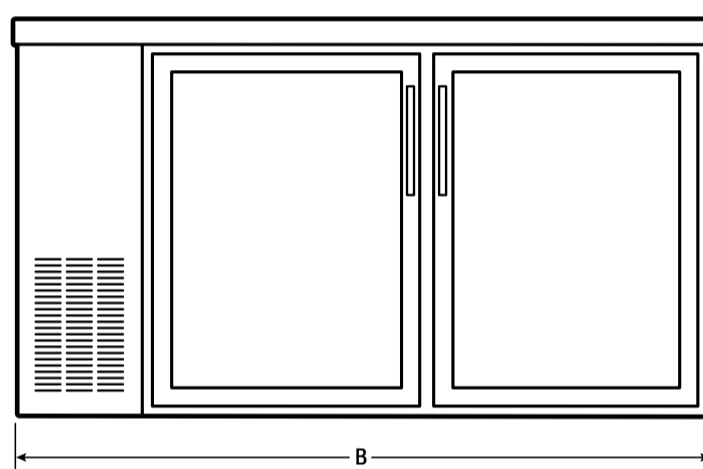

Front View

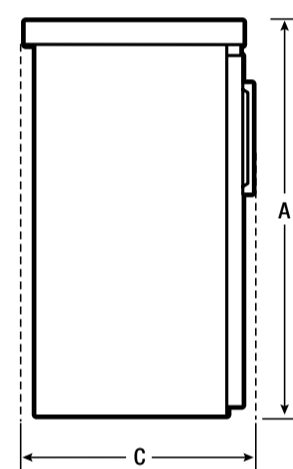

Side View



Plug Type (NEMA)
5-15P

EXTERIOR DIMENSIONS

Height A	36"
Width B	60-7/8"
Overall Depth (Including Door & Handle) C	24-1/2"
Cabinet Depth D	24-1/2"
Depth (with Door 90° Open) E	47-1/2"

CERTIFICATIONS AND APPROVALS

Safety Certification	ETL
Sanitation Certification	ETL

ACCESSORIES

Shelf	5304497342
Shelf Clip	297121900

Kelvinator

USA • 10200 David Taylor Drive • Charlotte, NC 28262 • 1-866-738-1640 • kelvinator.com

CANADA • 5855 Terry Fox Way • Mississauga, ON L5V 3E4

KCBB60G 06/15

© 2015 Electrolux Home Products, Inc.

High standards of quality at Electrolux Home Products, Inc. mean we are constantly working to improve our products. We reserve the right to change specifications or discontinue models without notice.



19.6 CU. FT. BACK BAR REFRIGERATOR

KCBB72GB



Fin & Tube Condenser improves performance in high temperature environments

Automatic Defrost Cooling System provides worry-free performance

1/3 HP Compressor

**Painted Steel Exterior/
Stainless Steel Interior**

Mechanical Control

Adjustable Shelves Vinyl-Coated Steel

Stay-Open Self-Closing Doors

Locking Doors & Key protect the contents of the unit



Mechanical Control

Select temperatures as required.

Locking Doors

Secure the inventory.

Heavy Duty Adjustable Shelves

Shelves that are easy to handle and keep clean.

TECHNICAL SPECIFICATIONS

MODEL	KCBB72GB
Product Line	Refrigerator
Door(s)/Type	3 Door Swing
Capacity (Cu. Ft.)	19.6
Condenser Type	Fin & Tube
Automatic Defrost Cooling System	Yes
Compressor Horsepower	1/3
Exterior Finish	Painted Steel
Interior Finish	Stainless Steel (304)
Shelves (Number/Type)	6/Vinyl-Coated Steel
Control	Mechanical
Temperature Display Location	External
Temperature Range	32 to 38°F
Voltage Rating	115V/60Hz
Run Amps	6.4
Plug Type	NEMA 5-15P
Shipping Weight (Lbs.)	410
Warranty	3 Year/5 Year

kelvinator.com



19.6 CU. FT. BACK BAR REFRIGERATOR

KCBB72GB

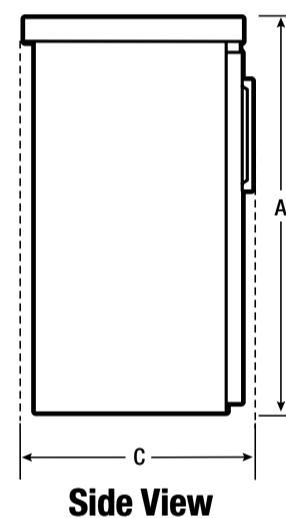
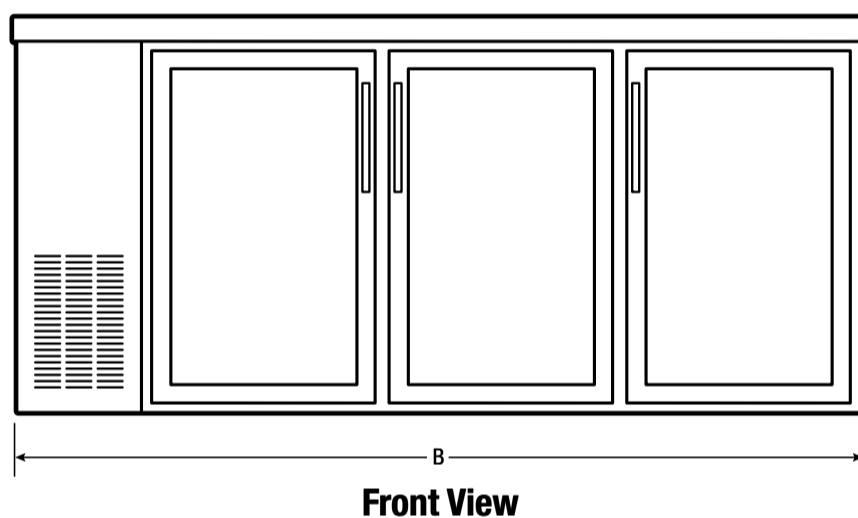
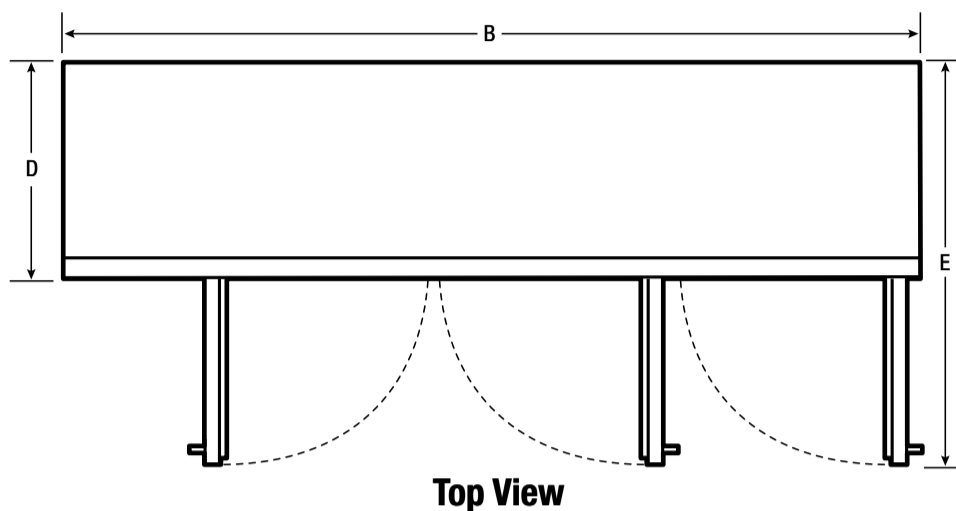

Plug Type (NEMA)
5-15P

EXTERIOR DIMENSIONS

Height A	36"
Width B	72-7/8"
Overall Depth (Including Door & Handle) C	24-1/2"
Cabinet Depth D	24-1/2"
Depth (with Door 90° Open) E	43"

CERTIFICATIONS AND APPROVALS

Safety Certification	ETL
Sanitation Certification	ETL

ACCESSORIES

Shelf	5304497343
Shelf Clip	297121900



USA • 10200 David Taylor Drive • Charlotte, NC 28262 • 1-866-738-1640 • kelvinator.com
CANADA • 5855 Terry Fox Way • Mississauga, ON L5V 3E4

KCBB72G 06/15

© 2015 Electrolux Home Products, Inc.

High standards of quality at Electrolux Home Products, Inc. mean we are constantly working to improve our products. We reserve the right to change specifications or discontinue models without notice.

13 CU. FT. BOTTLE COOLER

KCBC50



Dynamic Condenser improves performance in high temperature environments

Automatic Defrost Cooling System provides worry-free performance

1/3 HP Compressor

**Painted Steel Exterior/
Painted Aluminum Interior**

Mechanical Control

Adjustable Dividers Vinyl-Coated Steel

Locking Lids & Key protect the contents of the unit



Mechanical Control

Select temperatures as required.

Locking Lids

Secure the inventory.

Adjustable Dividers

Customize bottle storage effortlessly.

TECHNICAL SPECIFICATIONS

MODEL	KCBC50
Product Line	Bottle Cooler
Capacity (Cu. Ft.)	13.0
Capacity (Cases)	18 Cases (12 oz. Cans)
Condenser Type	Dynamic
Automatic Defrost Cooling System	Yes
Compressor Horsepower	1/3
Exterior Finish	Painted Steel
Interior Finish	Painted Aluminum
Dividers (Number/Type)	3/Vinyl-Coated Steel
Control	Mechanical
Temperature Range	32 to 50°F
Voltage Rating	115V/60Hz
Run Amps	8.0
Plug Type	NEMA 5-15P
Shipping Weight (Lbs.)	223
Warranty	3 Year/5 Year



13 CU. FT. BOTTLE COOLER

KCBC50

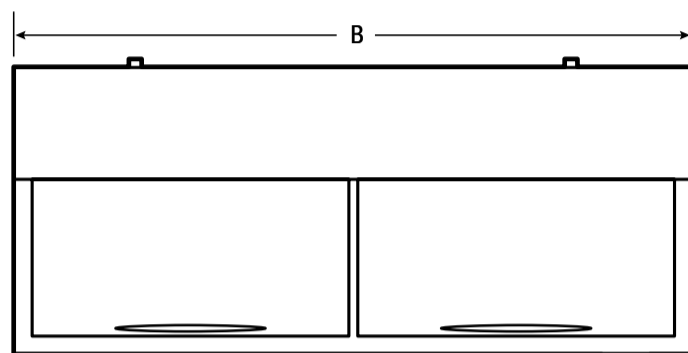

Top View

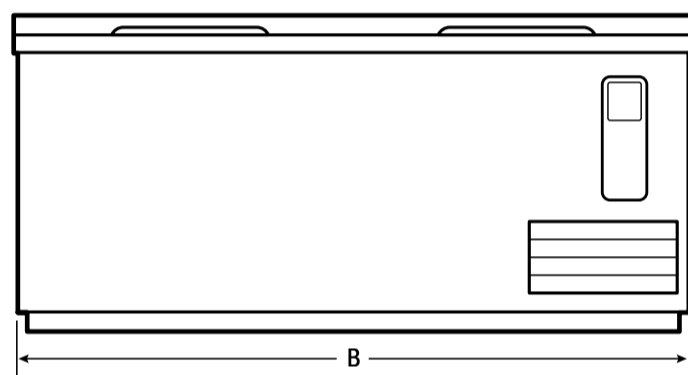

Front View

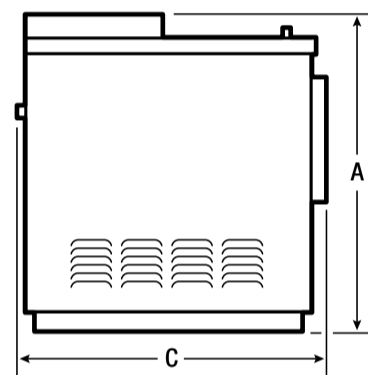

Side View



Plug Type (NEMA)
5-15P

EXTERIOR DIMENSIONS

Height A	34"
Width B	50"
Overall Depth (Including Door & Handle) C	28"

ACCESSORIES

Lock	5304486631
Divider Shelf	5304486632

CERTIFICATIONS AND APPROVALS

Safety Certification	ETL
Sanitation Certification	ETL



USA • 10200 David Taylor Drive • Charlotte, NC 28262 • 1-866-738-1640 • kelvinator.com
CANADA • 5855 Terry Fox Way • Mississauga, ON L5V 3E4

KCBC50 07/14

© 2015 Electrolux Home Products, Inc.

High standards of quality at Electrolux Home Products, Inc. mean we are constantly working to improve our products. We reserve the right to change specifications or discontinue models without notice.



18 CU. FT. BOTTLE COOLER

KCBC65



Dynamic Condenser improves performance in high temperature environments

Automatic Defrost Cooling System provides worry-free performance

1/3 HP Compressor

**Painted Steel Exterior/
Painted Aluminum Interior**

Mechanical Control

Adjustable Dividers Vinyl-Coated Steel

Locking Lids & Key protect the contents of the unit



Mechanical Control

Select temperatures as required.



Locking Lids

Secure the inventory.



Adjustable Dividers

Customize bottle storage effortlessly.

TECHNICAL SPECIFICATIONS

MODEL	KCBC65
Product Line	Bottle Cooler
Capacity (Cu. Ft.)	18.0
Capacity (Cases)	22 Cases (12 oz. Cans)
Condenser Type	Dynamic
Automatic Defrost Cooling System	Yes
Compressor Horsepower	1/3
Exterior Finish	Painted Steel
Interior Finish	Painted Aluminum
Dividers (Number/Type)	3/Vinyl-Coated Steel
Control	Mechanical
Temperature Range	32 to 50°F
Voltage Rating	115V/60Hz
Run Amps	8.5
Plug Type	NEMA 5-15P
Shipping Weight (Lbs.)	296
Warranty	3 Year/5 Year

kelvinator.com



18 CU. FT. BOTTLE COOLER

KCBC65

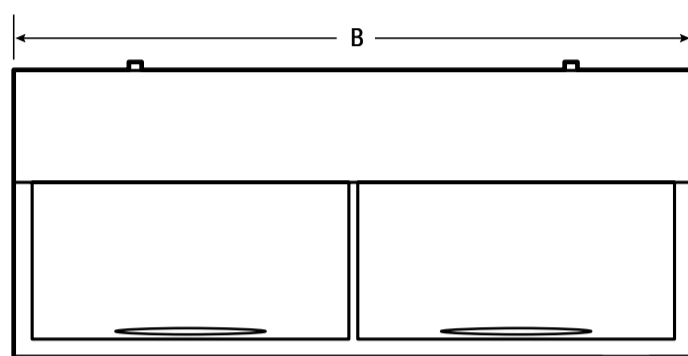

Top View

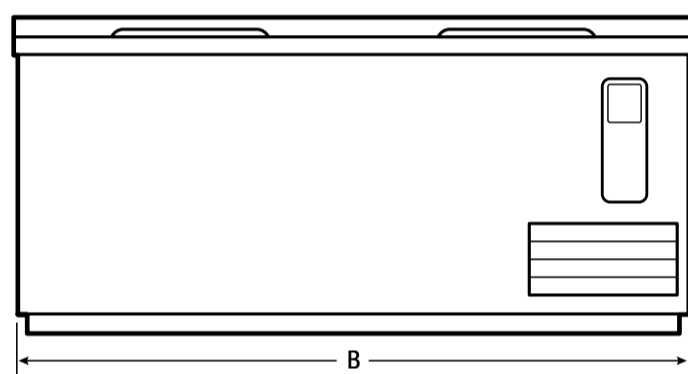

Front View

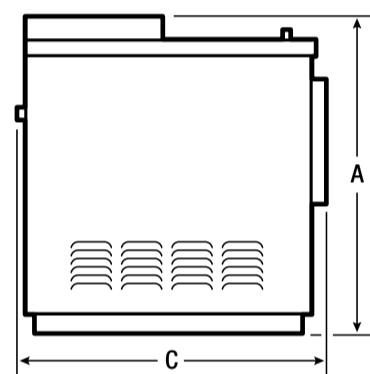

Side View



Plug Type (NEMA)
5-15P

EXTERIOR DIMENSIONS

Height A	34"
Width B	65"
Overall Depth (Including Door & Handle) C	28"

ACCESSORIES

Lock	5304486631
Divider Shelf	5304486632

CERTIFICATIONS AND APPROVALS

Safety Certification	ETL
Sanitation Certification	ETL

Kelvinator

USA • 10200 David Taylor Drive • Charlotte, NC 28262 • 1-866-738-1640 • kelvinator.com
CANADA • 5855 Terry Fox Way • Mississauga, ON L5V 3E4

KCBC65 07/14

© 2015 Electrolux Home Products, Inc.

High standards of quality at Electrolux Home Products, Inc. mean we are constantly working to improve our products. We reserve the right to change specifications or discontinue models without notice.

Kelvinator 



MILK
COOLERS

13.6 CU. FT. SCHOOL MILK COOLER

KCMC34RW



- 1/5 HP Compressor**
- Stainless Steel Interior**
- Electronic Controls**
- External Temperature Display**
- Removable Door Gasket**
- Locking Lid & Key** protect the contents of the unit
- Heavy Duty Casters**
- Interior Drain**



Electronic Digital Temperature Control

Quick set digital control and display for easy monitoring.

Stainless Steel Interior

Durable and easy to clean for daily commercial use.

Heavy-Duty, Locking Casters

Keeps unit in place but allows position adjusting.

TECHNICAL SPECIFICATIONS

MODEL	KCMC34RW
Product Line	Refrigerator
Capacity (Cu. Ft.)	13.6
Condenser Type	Fin & Tube
Automatic Defrost Cooling System	Yes
Compressor Horsepower	1/5
Exterior Finish	Painted Steel
Interior Finish	Stainless Steel (304)
Shelves (Number/Type)	1/Vinyl-Coated Steel
Control	Electronic
Temperature Display Location	Back Side
Temperature Range	32 to 50°F
Voltage Rating	115V/60Hz
Run Amps	6.4
Plug Type	NEMA 5-15P
Shipping Weight (Lbs.)	253
Warranty	3 Year/5 Year



13.6 CU. FT. SCHOOL MILK COOLER

KCMC34RW

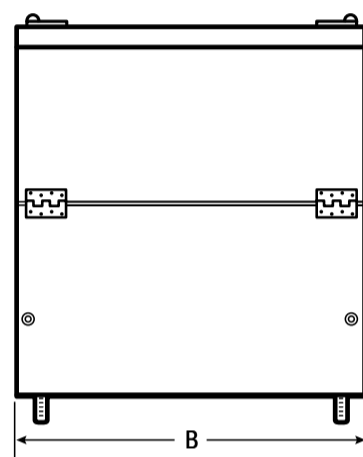

Front View

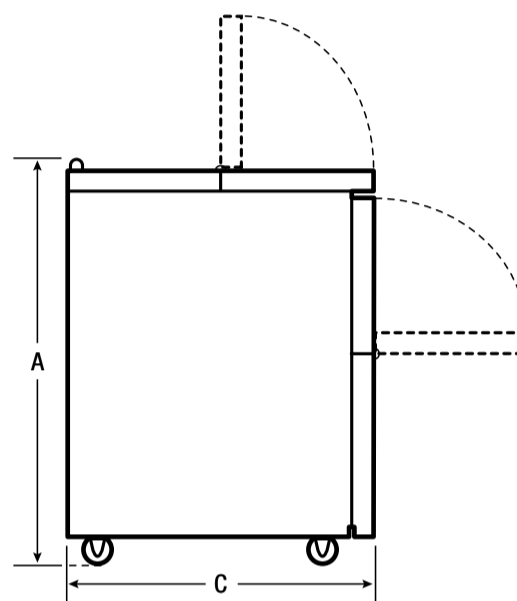

Side View



Plug Type (NEMA)
5-15P

EXTERIOR DIMENSIONS

Height A (Including Casters)	42"
Width B	34"
Cabinet Depth C	34"

CERTIFICATIONS AND APPROVALS

Safety Certification	ETL
Sanitation Certification	ETL

Kelvinator

USA • 10200 David Taylor Drive • Charlotte, NC 28262 • 1-866-738-1640 • kelvinator.com

CANADA • 5855 Terry Fox Way • Mississauga, ON L5V 3E4

KCMC34R 06/15

© 2015 Electrolux Home Products, Inc.

High standards of quality at Electrolux Home Products, Inc. mean we are constantly working to improve our products. We reserve the right to change specifications or discontinue models without notice.



- 1/5 HP Compressor**
- Stainless Steel Interior**
- Electronic Controls**
- External Temperature Display**
- Removable Door Gasket**
- Locking Lid & Key** protect the contents of the unit
- Heavy Duty Casters**
- Interior Drain**



Electronic Digital Temperature Control

Quick set digital control and display for easy monitoring.

Stainless Steel Interior

Durable and easy to clean for daily commercial use.

Heavy-Duty, Locking Casters

Keeps unit in place but allows position adjusting.

TECHNICAL SPECIFICATIONS

MODEL	KCMC49RW
Product Line	Refrigerator
Capacity (Cu. Ft.)	20.0
Condenser Type	Fin & Tube
Automatic Defrost Cooling System	Yes
Compressor Horsepower	1/5
Exterior Finish	Painted Steel
Interior Finish	Stainless Steel (304)
Shelves (Number/Type)	1/Vinyl-Coated Wire
Control	Electronic
Temperature Display Location	Back Side
Temperature Range	32 to 38°F
Voltage Rating	115V/60Hz
Run Amps	6.4
Plug Type	NEMA 5-15P
Shipping Weight (Lbs.)	364
Warranty	3 Year/5 Year



20.0 CU. FT. SCHOOL MILK COOLER

KCMC49RW

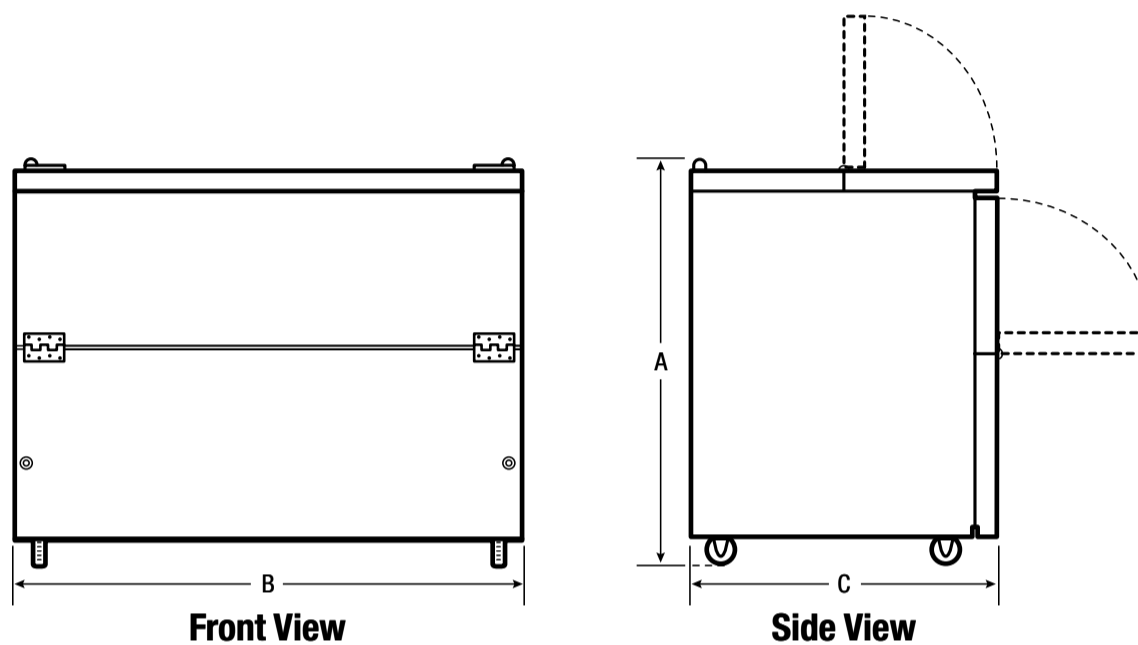

Plug Type (NEMA)
5-15P

EXTERIOR DIMENSIONS

Height A (Including Casters)	42"
Width B	49"
Cabinet Depth C	34"

CERTIFICATIONS AND APPROVALS

Safety Certification	ETL
Sanitation Certification	ETL

Kelvinator

USA • 10200 David Taylor Drive • Charlotte, NC 28262 • 1-866-738-1640 • kelvinator.com

CANADA • 5855 Terry Fox Way • Mississauga, ON L5V 3E4

KCMC49R 06/15

© 2015 Electrolux Home Products, Inc.

High standards of quality at Electrolux Home Products, Inc. mean we are constantly working to improve our products. We reserve the right to change specifications or discontinue models without notice.



24.0 CU. FT. SCHOOL MILK COOLER

KCMC58RW



- 1/5 HP Compressor**
- Stainless Steel Interior**
- Electronic Controls**
- External Temperature Display**
- Removable Door Gasket**
- Locking Lid & Key** protect the contents of the unit
- Heavy Duty Casters**
- Interior Drain**



Electronic Digital Temperature Control

Quick set digital control and display for easy monitoring.

Stainless Steel Interior

Durable and easy to clean for daily commercial use.

Heavy-Duty, Locking Casters

Keeps unit in place but allows position adjusting.

TECHNICAL SPECIFICATIONS

MODEL	KCMC58RW
Product Line	Refrigerator
Capacity (Cu. Ft.)	24.0
Condenser Type	Fin & Tube
Automatic Defrost Cooling System	Yes
Compressor Horsepower	1/5
Exterior Finish	Painted Steel
Interior Finish	Stainless Steel (304)
Shelves (Number/Type)	1/Vinyl-Coated Steel
Control	Electronic
Temperature Display Location	Back Side
Temperature Range	32 to 50°F
Voltage Rating	115V/60Hz
Run Amps	6.4
Plug Type	NEMA 5-15P
Shipping Weight (Lbs.)	407
Warranty	3 Year/5 Year

kelvinator.com



24.0 CU. FT. SCHOOL MILK COOLER

KCMC58RW

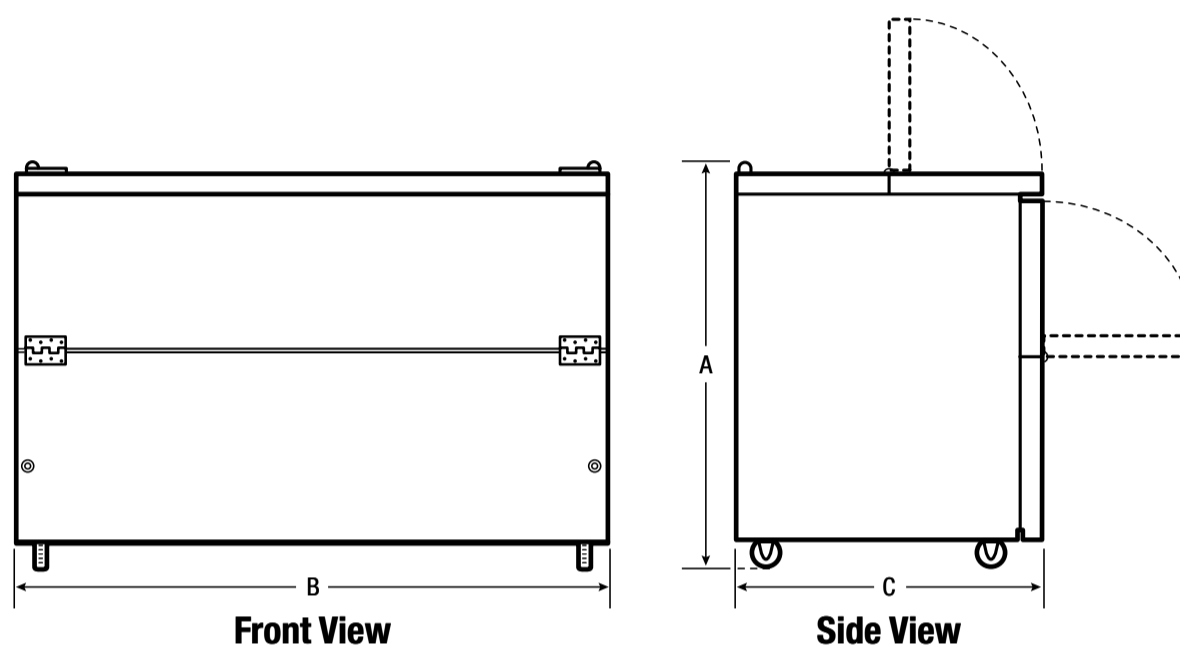

Plug Type (NEMA)
5-15P

EXTERIOR DIMENSIONS

Height A (Including Casters)	42"
Width B	58"
Cabinet Depth C	34"

CERTIFICATIONS AND APPROVALS

Safety Certification	ETL
Sanitation Certification	ETL

Kelvinator

USA • 10200 David Taylor Drive • Charlotte, NC 28262 • 1-866-738-1640 • kelvinator.com

CANADA • 5855 Terry Fox Way • Mississauga, ON L5V 3E4

KCMC58R 06/15

© 2015 Electrolux Home Products, Inc.

High standards of quality at Electrolux Home Products, Inc. mean we are constantly working to improve our products. We reserve the right to change specifications or discontinue models without notice.

Kelvinator 



CHEST
FREEZERS



7 CU. FT. CHEST FREEZER

KCCF070QW



- Static Condenser**
- 1/6 HP Compressor**
- Painted Steel Exterior & Interior**
- Mechanical Control**
- Internal Temperature Display**
- Freezer Basket**
- Locking Lids & Key** Protect the contents of the unit
- Heavy Duty Casters**



NSF®-Certified Basket

Durable and reliable for safety in food storage.

NSF®-Certified Temperature Gauge

Durable and reliable for safety in food storage.

Heavy-Duty, Locking Casters

Keeps unit in place but allows position adjusting.

TECHNICAL SPECIFICATIONS

MODEL	KCCF070QW
Product Line	Chest Freezer
Capacity (Cu. Ft.)	7.35
Condenser Type	Static
Automatic Defrost Cooling System	No
Compressor Horsepower	1/6
Exterior Finish	Textured Painted Steel
Interior Finish	Painted Steel
Freezer Baskets (Number/Type)	1/Wire
Control	Mechanical
Temperature Display Location	Internal
Temperature Range	-15 to 10°F
Interior Lighting	No
Voltage Rating	115V/5A
Run Amps	1.0
Plug Type	NEMA 5-15P
Shipping Weight (Lbs.)	82
Warranty	3 Year/5 Year

kelvinator.com



7 CU. FT. CHEST FREEZER

KCCF070QW

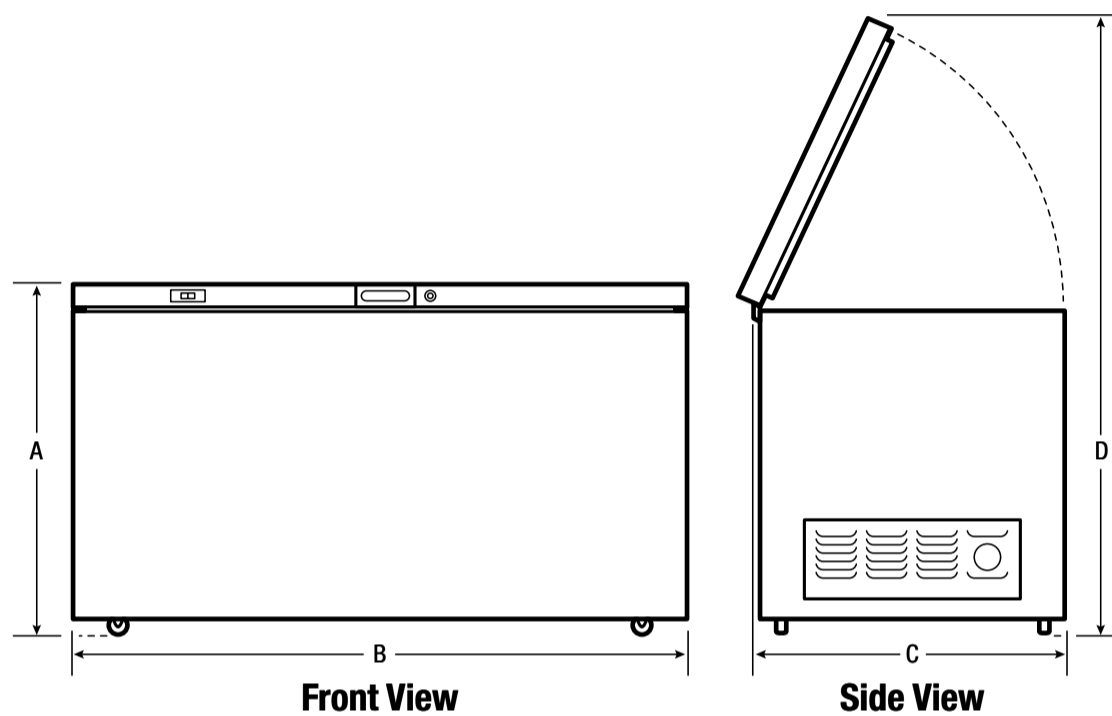

Plug Type (NEMA)
5-15P

EXTERIOR DIMENSIONS

Height A (Including Casters & Lid)	37"
Width B	37"
Cabinet Depth C	23-1/2"
Height (with Lid Open) D	55-5/16"

ACCESSORIES

Lock & Key	297090100
NSF® wire basket	297404901
Basket divider	296506200
NSF® thermometer	297070100

CERTIFICATIONS AND APPROVALS

ENERGY STAR® Qualified	Yes
Safety Certification	CSA
Sanitation Certification	NSF®

Kelvinator®

USA • 10200 David Taylor Drive • Charlotte, NC 28262 • 1-866-738-1640 • kelvinator.com

CANADA • 5855 Terry Fox Way • Mississauga, ON L5V 3E4

KCCF070Q 06/15

© 2015 Electrolux Home Products, Inc.

High standards of quality at Electrolux Home Products, Inc. mean we are constantly working to improve our products. We reserve the right to change specifications or discontinue models without notice.



16 CU. FT. CHEST FREEZER

KCCF160QW



- Static Condenser**
- 1/5 HP Compressor**
- Painted Steel Exterior & Interior**
- Mechanical Control**
- Internal Temperature Display**
- Freezer Basket**
- Locking Lids & Key** Protect the contents of the unit
- Heavy Duty Casters**



NSF®-Certified Basket

Durable and reliable for safety in food storage.

NSF®-Certified Temperature Gauge

Durable and reliable for safety in food storage.

Heavy-Duty, Locking Casters

Keeps unit in place but allows position adjusting.

TECHNICAL SPECIFICATIONS

MODEL	KCCF160QW
Product Line	Chest Freezer
Capacity (Cu. Ft.)	16
Condenser Type	Static
Automatic Defrost Cooling System	No
Compressor Horsepower	1/5
Exterior Finish	Textured Painted Steel
Interior Finish	Painted Steel
Freezer Baskets (Number/Type)	1/Wire
Control	Mechanical
Temperature Display Location	Internal
Temperature Range	-15 to 10°F
Interior Lighting	No
Voltage Rating	115V/5A
Run Amps	1.3
Plug Type	NEMA 5-15P
Shipping Weight (Lbs.)	179
Warranty	3 Year/5 Year

kelvinator.com



16 CU. FT. CHEST FREEZER

KCCF160QW

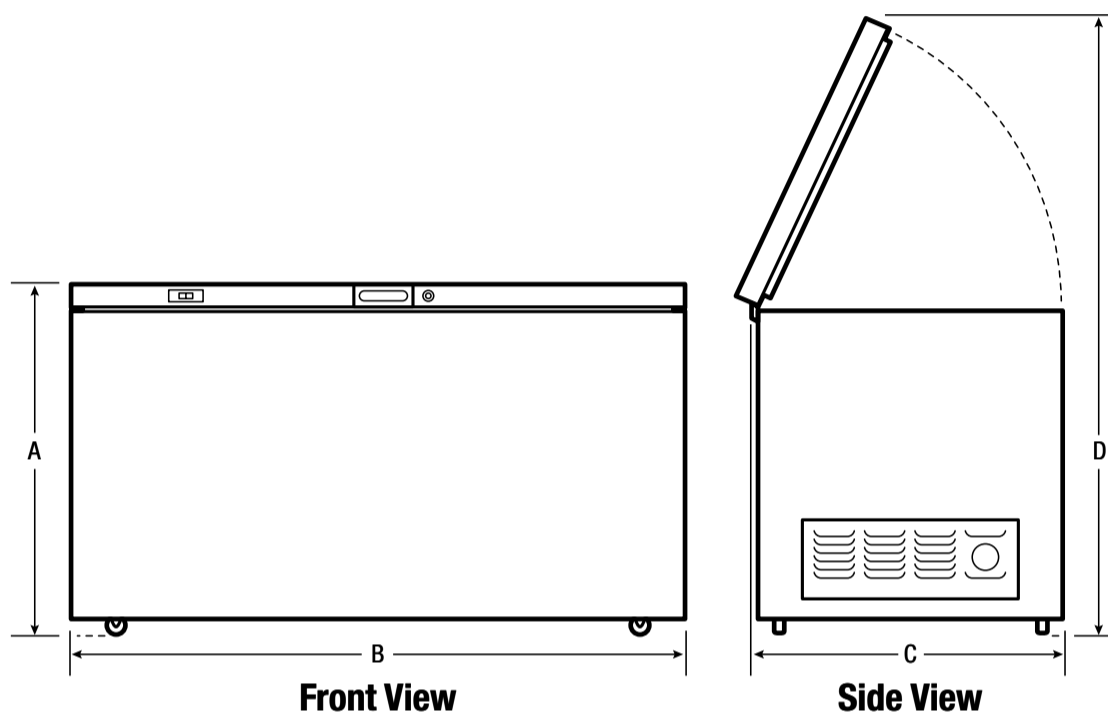

Plug Type (NEMA)
5-15P

EXTERIOR DIMENSIONS

Height A (Including Casters & Lid)	37"
Width B	56"
Cabinet Depth C	27-1/2"
Height (with Lid Open) D	62"

ACCESSORIES

Lock & Key	297090100
NSF® wire basket	297404901
Basket divider	296506200
NSF® thermometer	297070100

CERTIFICATIONS AND APPROVALS

ENERGY STAR® Qualified	Yes
Safety Certification	CSA
Sanitation Certification	NSF®



USA • 10200 David Taylor Drive • Charlotte, NC 28262 • 1-866-738-1640 • kelvinator.com
CANADA • 5855 Terry Fox Way • Mississauga, ON L5V 3E4

KCCF160Q 06/15

© 2015 Electrolux Home Products, Inc.

High standards of quality at Electrolux Home Products, Inc. mean we are constantly working to improve our products. We reserve the right to change specifications or discontinue models without notice.



18 CU. FT. CHEST FREEZER

KCCF180QW



- Static Condenser**
- 1/5 HP Compressor**
- Painted Steel Exterior & Interior**
- Mechanical Control**
- Internal Temperature Display**
- Freezer Basket**
- Locking Lids & Key** Protect the contents of the unit
- Heavy Duty Casters**
- Interior Lighting**



NSF®-Certified Basket

Durable and reliable for safety in food storage.

NSF®-Certified Temperature Gauge

Durable and reliable for safety in food storage.

Heavy-Duty, Locking Casters

Keeps unit in place but allows position adjusting.

TECHNICAL SPECIFICATIONS

MODEL	KCCF180QW
Product Line	Chest Freezer
Capacity (Cu. Ft.)	18
Condenser Type	Static
Automatic Defrost Cooling System	No
Compressor Horsepower	1/5
Exterior Finish	Textured Painted Steel
Interior Finish	Painted Steel
Freezer Baskets (Number/Type)	1/Wire
Control	Mechanical
Temperature Display Location	Internal
Temperature Range	-15 to 10°F
Interior Lighting	Yes
Voltage Rating	115V/5A
Run Amps	1.3
Plug Type	NEMA 5-15P
Shipping Weight (Lbs.)	200
Warranty	3 Year/5 Year

kelvinator.com



18 CU. FT. CHEST FREEZER

KCCF180QW

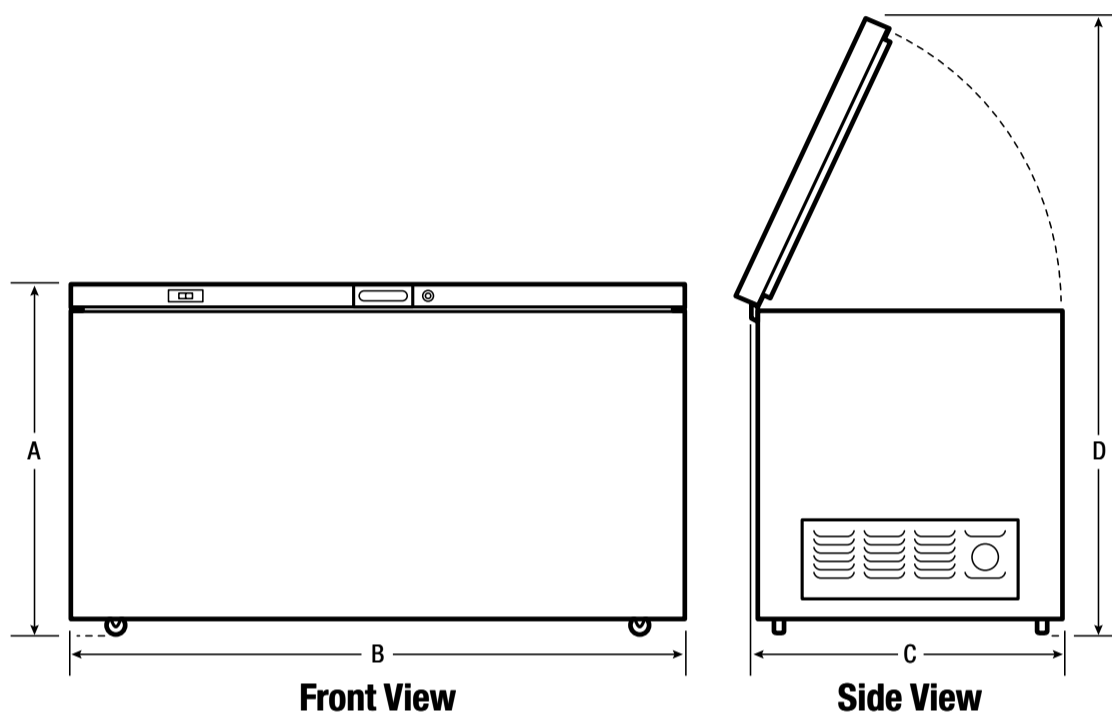

Plug Type (NEMA)
5-15P

EXTERIOR DIMENSIONS

Height A (Including Casters & Lid)	37"
Width B	61-1/2"
Cabinet Depth C	27-1/2"
Height (with Lid Open) D	62"

ACCESSORIES

Lock & Key	297090100
NSF® wire basket	297404901
Basket divider	296506200
NSF® thermometer	297070100

CERTIFICATIONS AND APPROVALS

ENERGY STAR® Qualified	Yes
Safety Certification	CSA
Sanitation Certification	NSF®

Kelvinator

USA • 10200 David Taylor Drive • Charlotte, NC 28262 • 1-866-738-1640 • kelvinator.com

CANADA • 5855 Terry Fox Way • Mississauga, ON L5V 3E4

KCCF180Q 06/15

© 2015 Electrolux Home Products, Inc.

High standards of quality at Electrolux Home Products, Inc. mean we are constantly working to improve our products. We reserve the right to change specifications or discontinue models without notice.



22 CU. FT. CHEST FREEZER

KCCF220QW



- Static Condenser**
- 1/4 HP Compressor**
- Painted Steel Exterior & Interior**
- Mechanical Control**
- Internal Temperature Display**
- Freezer Basket**
- Locking Lids & Key** Protect the contents of the unit
- Interior Lighting**



NSF®-Certified Basket

Durable and reliable for safety in food storage.

NSF®-Certified Temperature Gauge

Durable and reliable for safety in food storage.

Heavy-Duty, Locking Casters

Keeps unit in place but allows position adjusting.

TECHNICAL SPECIFICATIONS

MODEL	KCCF220QW
Product Line	Chest Freezer
Capacity (Cu. Ft.)	22
Condenser Type	Static
Automatic Defrost Cooling System	No
Compressor Horsepower	1/4
Exterior Finish	Textured Painted Steel
Interior Finish	Painted Steel
Freezer Baskets (Number/Type)	1/Wire
Control	Mechanical
Temperature Display Location	Internal
Temperature Range	-15 to 10°F
Interior Lighting	Yes
Voltage Rating	115V/5A
Run Amps	1.3
Plug Type	NEMA 5-15P
Shipping Weight (Lbs.)	221
Warranty	3 Year/5 Year

kelvinator.com



22 CU. FT. CHEST FREEZER

KCCF220QW

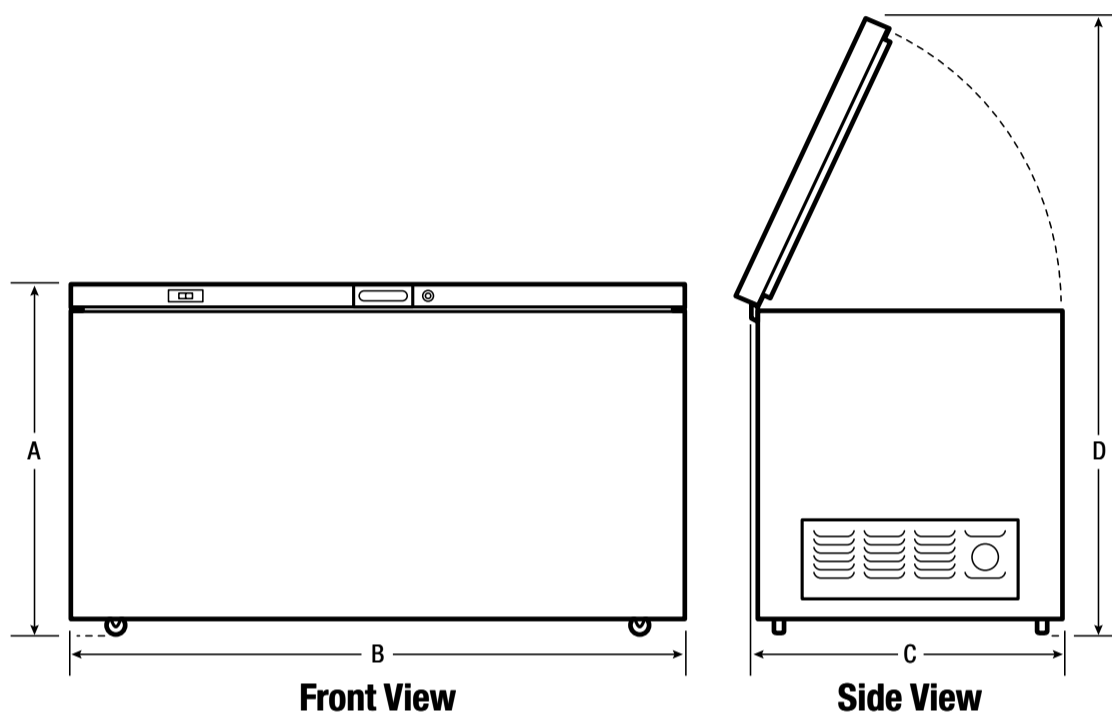

Plug Type (NEMA)
5-15P

EXTERIOR DIMENSIONS

Height A (Including Casters & Lid)	37"
Width B	73-1/2"
Cabinet Depth C	27-1/2"
Height (with Lid Open) D	62"

ACCESSORIES

Lock & Key	297090100
NSF® wire basket	297404901
Basket divider	296506200
NSF® thermometer	297070100

CERTIFICATIONS AND APPROVALS

ENERGY STAR® Qualified	Yes
Safety Certification	CSA
Sanitation Certification	NSF®

Kelvinator®

USA • 10200 David Taylor Drive • Charlotte, NC 28262 • 1-866-738-1640 • kelvinator.com

CANADA • 5855 Terry Fox Way • Mississauga, ON L5V 3E4

KCCF220Q 06/15

© 2015 Electrolux Home Products, Inc.

High standards of quality at Electrolux Home Products, Inc. mean we are constantly working to improve our products. We reserve the right to change specifications or discontinue models without notice.



7 CU. FT. NOVELTY FREEZER

KCNF070QW



- Static Condenser**
- 1/6 HP Compressor**
- Painted Steel Exterior & Interior**
- Mechanical Control**
- Internal Temperature Display**
- Freezer Basket**
- Locking Lids & Key** Protect the contents of the unit
- Heavy Duty Casters**



NSF®-Certified Basket

Durable and reliable for safety in food storage.

NSF®-Certified Temperature Gauge

Durable and reliable for safety in food storage.

Heavy-Duty, Locking Casters

Keeps unit in place but allows position adjusting.

TECHNICAL SPECIFICATIONS

MODEL	KCNF070QW
Product Line	Novelty Freezer
Capacity (Cu. Ft.)	7.37
Condenser Type	Static
Automatic Defrost Cooling System	No
Compressor Horsepower	1/6
Exterior Finish	Textured Painted Steel
Interior Finish	Painted Steel
Freezer Baskets (Number/Type)	1/Wire
Control	Mechanical
Temperature Display Location	Internal
Temperature Range	-10 to 10°F
Voltage Rating	115V/5A
Run Amps	1.0
Plug Type	NEMA 5-15P
Shipping Weight (Lbs.)	127
Warranty	3 Year/5 Year

kelvinator.com



7 CU. FT. NOVELTY FREEZER

KCNF070QW

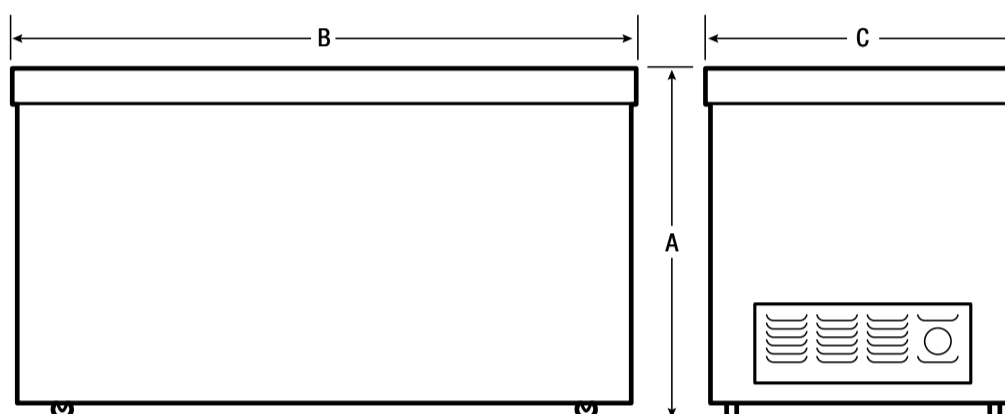

Plug Type (NEMA)
5-15P

EXTERIOR DIMENSIONS

Height A (Including Casters)	38"
Width B	37"
Cabinet Depth C	23-1/2"

ACCESSORIES

Lock Assembly	216621200
Key	297147700
NSF® wire basket	297405000
NSF® thermometer	297070100

CERTIFICATIONS AND APPROVALS

ENERGY STAR® Qualified	Yes
Safety Certification	CSA
Sanitation Certification	NSF®

Kelvinator®

USA • 10200 David Taylor Drive • Charlotte, NC 28262 • 1-866-738-1640 • kelvinator.com

CANADA • 5855 Terry Fox Way • Mississauga, ON L5V 3E4

KCNF070Q 06/15

© 2015 Electrolux Home Products, Inc.

High standards of quality at Electrolux Home Products, Inc. mean we are constantly working to improve our products. We reserve the right to change specifications or discontinue models without notice.



16 CU. FT. NOVELTY FREEZER

KCNF160QW



- Static Condenser**
- 1/5 HP Compressor**
- Painted Steel Exterior & Interior**
- Mechanical Control**
- Internal Temperature Display**
- Freezer Basket**
- Locking Lids & Key** protect the contents of the unit
- Heavy Duty Casters**



NSF®-Certified Basket
Durable and reliable for safety in food storage.

NSF®-Certified Temperature Gauge
Durable and reliable for safety in food storage.

Heavy-Duty, Locking Casters
Keeps unit in place but allows position adjusting.

TECHNICAL SPECIFICATIONS

MODEL	KCNF160QW
Product Line	Novelty Freezer
Capacity (Cu. Ft.)	16
Condenser Type	Static
Automatic Defrost Cooling System	No
Compressor Horsepower	1/5
Exterior Finish	Textured Painted Steel
Interior Finish	Painted Steel
Freezer Baskets (Number/Type)	1/Wire
Control	Mechanical
Temperature Display Location	Internal
Temperature Range	-10 to 10°F
Voltage Rating	115V/5A
Run Amps	1.3
Plug Type	NEMA 5-15P
Shipping Weight (Lbs.)	182
Warranty	3 Year/5 Year

kelvinator.com



16 CU. FT. NOVELTY FREEZER

KCNF160QW

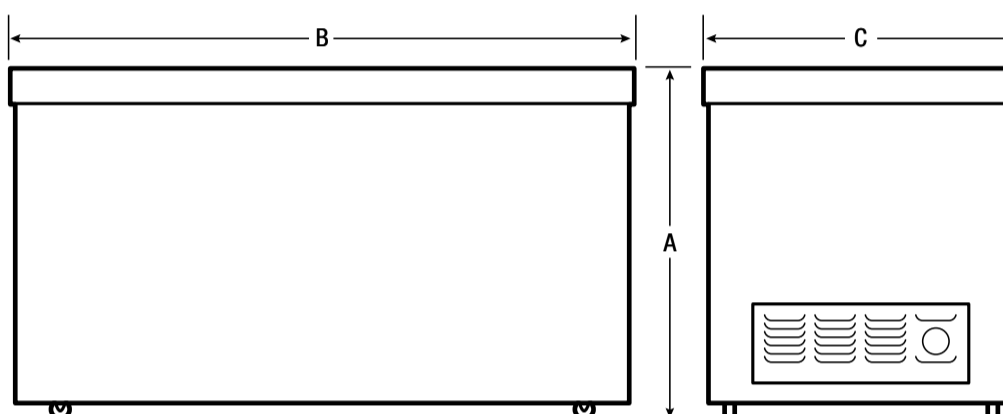

Plug Type (NEMA)
5-15P

EXTERIOR DIMENSIONS

Height A (Including Casters)	38"
Width B	56"
Cabinet Depth C	27-1/2"

ACCESSORIES

Lock Assembly	216621200
Key	297147700
NSF® wire basket	297405000
NSF® thermometer	297070100

CERTIFICATIONS AND APPROVALS

ENERGY STAR® Qualified	Yes
Safety Certification	CSA
Sanitation Certification	NSF®



USA • 10200 David Taylor Drive • Charlotte, NC 28262 • 1-866-738-1640 • kelvinator.com
CANADA • 5855 Terry Fox Way • Mississauga, ON L5V 3E4

KCNF160Q 06/15

© 2015 Electrolux Home Products, Inc.

High standards of quality at Electrolux Home Products, Inc. mean we are constantly working to improve our products. We reserve the right to change specifications or discontinue models without notice.



17 CU. FT. NOVELTY FREEZER

KCNF180QW



- Static Condenser**
- 1/5 HP Compressor**
- Painted Steel Exterior & Interior**
- Mechanical Control**
- Internal Temperature Display**
- Freezer Basket**
- Locking Lids & Key** protect the contents of the unit
- Heavy Duty Casters**



NSF®-Certified Basket
Durable and reliable for safety in food storage.

NSF®-Certified Temperature Gauge
Durable and reliable for safety in food storage.

Heavy-Duty, Locking Casters
Keeps unit in place but allows position adjusting.

TECHNICAL SPECIFICATIONS

MODEL	KCNF180QW
Product Line	Novelty Freezer
Capacity (Cu. Ft.)	17.47
Condenser Type	Static
Automatic Defrost Cooling System	No
Compressor Horsepower	1/5
Exterior Finish	Textured Painted Steel
Interior Finish	Painted Steel
Freezer Baskets (Number/Type)	1/Wire
Control	Mechanical
Temperature Display Location	Internal
Temperature Range	-10 to 10°F
Voltage Rating	115V/5A
Run Amps	1.3
Plug Type	NEMA 5-15P
Shipping Weight (Lbs.)	217
Warranty	3 Year/5 Year

kelvinator.com



17 CU. FT. NOVELTY FREEZER

KCNF180QW

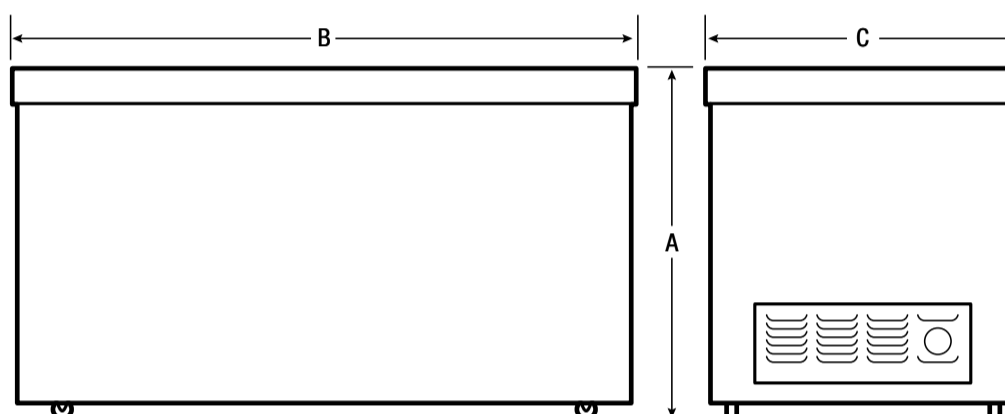

Plug Type (NEMA)
5-15P

EXTERIOR DIMENSIONS

Height A (Including Casters)	38"
Width B	61-1/4"
Cabinet Depth C	27-1/2"

ACCESSORIES

Lock Assembly	216621200
Key	297147700
NSF® wire basket	297405000
NSF® thermometer	297070100

CERTIFICATIONS AND APPROVALS

ENERGY STAR® Qualified	Yes
Safety Certification	CSA
Sanitation Certification	NSF®



USA • 10200 David Taylor Drive • Charlotte, NC 28262 • 1-866-738-1640 • kelvinator.com
CANADA • 5855 Terry Fox Way • Mississauga, ON L5V 3E4

KCNF180Q 06/15

© 2015 Electrolux Home Products, Inc.

High standards of quality at Electrolux Home Products, Inc. mean we are constantly working to improve our products. We reserve the right to change specifications or discontinue models without notice.

Kelvinator ®

DISCONTINUED
MODELS



18 CU. FT. REACH-IN REFRIGERATOR

KRS220RH



Dynamic Condenser improves performance in high temperature environments

Automatic Defrost Cooling System provides worry-free performance

1/3 HP Compressor

Mechanical Control

Internal Temperature Display

Adjustable Shelves

Self-Closing Doors with 90-degree stay-open feature

Lock & Key protects the contents of the unit

Heavy Duty Casters

Reversible Door



Vinyl Heavy Duty Adjustable Shelves

Shelves that are easy to handle and keep clean.



NSF®-Certified Temperature

Durable and reliable for safety in food storage.



Heavy-Duty, Locking Casters

Keeps unit in place but allows position adjusting.

TECHNICAL SPECIFICATIONS

MODEL	KRS220RH
Product Line	Refrigerator
Capacity (Cu. Ft.)	18.4
Condenser Type	Dynamic
Automatic Defrost Cooling System	Yes
Compressor Horsepower	1/3
Exterior Finish	Textured Painted Steel
Interior Finish	Smooth Painted Steel
Shelves (Number/Type)	3/Vinyl-Coated Steel
Control	Mechanical
Temperature Display Location	Internal
Temperature Range	32 to 44°F
Voltage Rating	120V/5A
Run Amps	1.3
Plug Type	NEMA 5-15P
Shipping Weight (Lbs.)	275
Warranty	3 Year/5 Year

kelvinator.com



18 CU. FT. REACH-IN REFRIGERATOR

KRS220RH

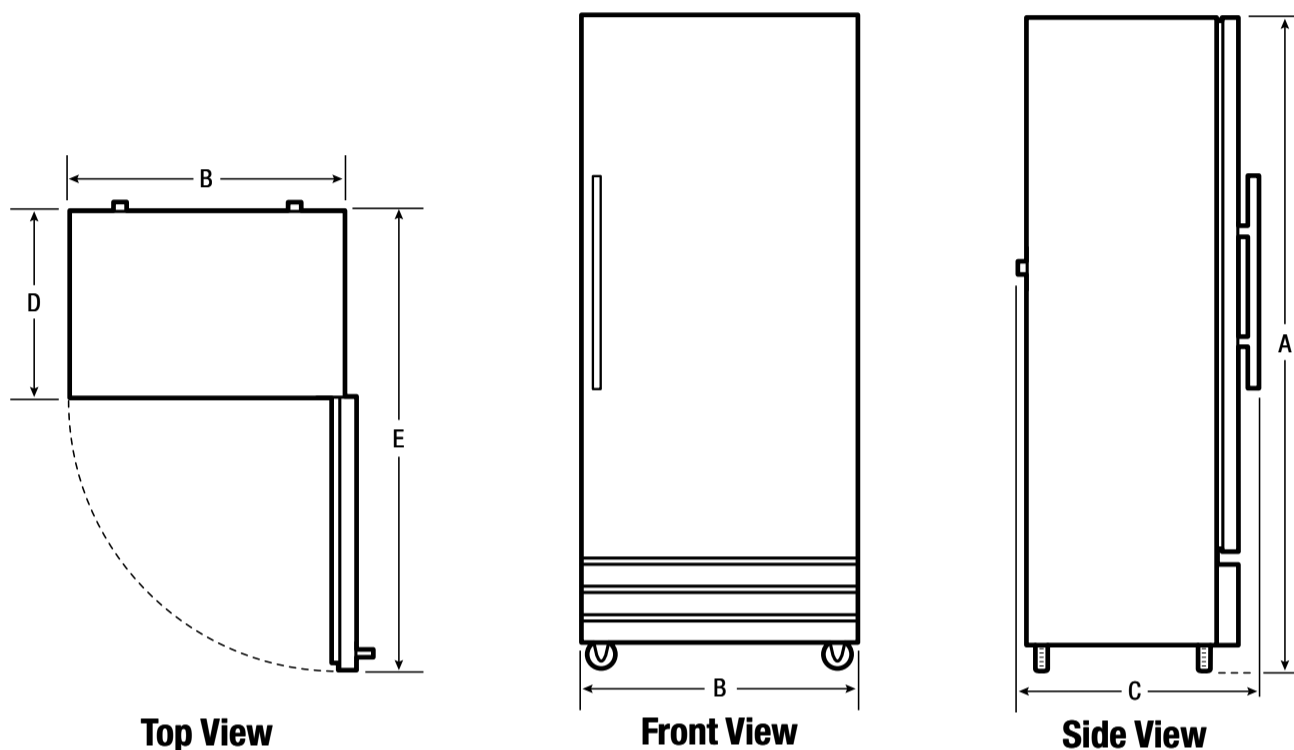

Plug Type (NEMA)
5-15P

EXTERIOR DIMENSIONS

Height A (Including Casters)	75-7/8"
Width B	32"
Overall Depth (Including Door & Handle) C	31-1/8"
Cabinet Depth D	26-3/8"
Depth (with Door 90° Open) E	59-3/8"

CERTIFICATIONS AND APPROVALS

ENERGY STAR® Qualified	Yes
Safety Certification	CSA
Sanitation Certification	NSF®

ACCESSORIES

Deep shelf (<i>Fits all except top position, white finish</i>)	216384002
Shallow top shelf (<i>Only fits top position, white finish</i>)	216386202
Trivet, white finish	216331802
Shelf support clips (<i>Sold as singles, requires 4 per shelf</i>)	297121900
Pan slide kit (<i>Includes 2 racks/4 clips, holds 8 pans 18" x 26"</i>)	PANRACKKIT
Casters, Front	297206600
Casters, Back	297206500
Caster hardware kit	297256300
Key for lock	216362800
Upright locks	216362700



USA • 10200 David Taylor Drive • Charlotte, NC 28262 • 1-866-738-1640 • kelvinator.com
CANADA • 5855 Terry Fox Way • Mississauga, ON L5V 3E4

KRS220RH 06/15

© 2015 Electrolux Home Products, Inc.

High standards of quality at Electrolux Home Products, Inc. mean we are constantly working to improve our products. We reserve the right to change specifications or discontinue models without notice.



18 CU. FT. REACH-IN FREEZER

KFS220RH



Dynamic Condenser improves performance in high temperature environments

Automatic Defrost Cooling System provides worry-free performance

1/2 HP Compressor

Mechanical Control

Internal Temperature Display

Adjustable Shelves

Self-Closing Doors with 90-degree stay-open feature

Lock & Key protects the contents of the unit

Heavy Duty Casters

Reversible Door



Vinyl Heavy Duty Adjustable Shelves

Shelves that are easy to handle and keep clean.



NSF®-Certified Temperature

Durable and reliable for safety in food storage.



Heavy-Duty, Locking Casters

Keeps unit in place but allows position adjusting.

TECHNICAL SPECIFICATIONS

MODEL	KFS220RH
Product Line	Freezer
Capacity (Cu. Ft.)	18.4
Condenser Type	Dynamic
Automatic Defrost Cooling System	Yes
Compressor Horsepower	1/2
Exterior Finish	Textured Painted Steel
Interior Finish	Smooth Painted Steel
Shelves (Number/Type)	3/Vinyl-Coated Steel
Control	Mechanical
Temperature Display Location	Internal
Temperature Range	-10 to 10°F
Voltage Rating	120V/5A
Run Amps	2.3
Plug Type	NEMA 5-15P
Shipping Weight (Lbs.)	275
Warranty	3 Year/5 Year

kelvinator.com



18 CU. FT. REACH-IN FREEZER

KFS220RH

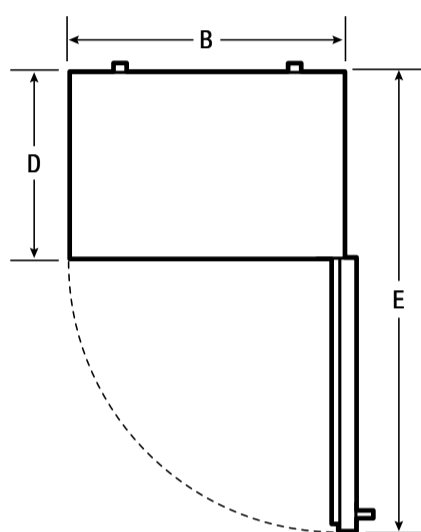

Top View

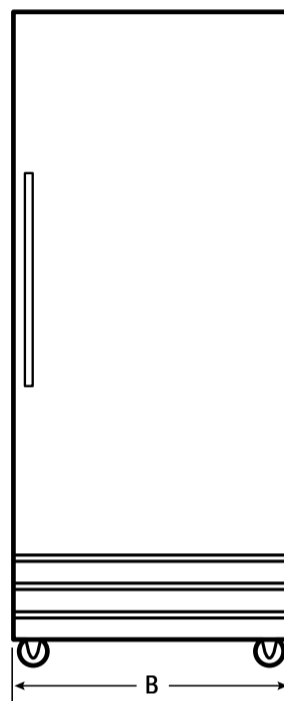

Front View

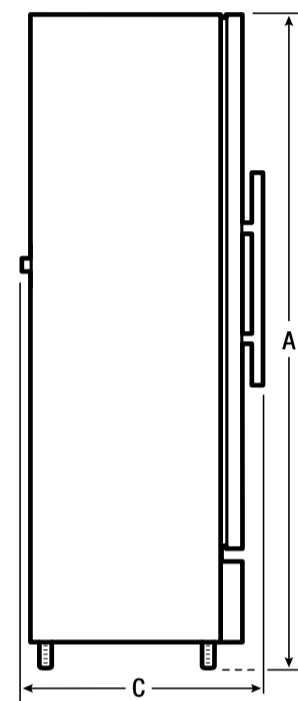

Side View



Plug Type (NEMA)
5-15P

EXTERIOR DIMENSIONS

Height A (Including Casters)	75-7/8"
Width B	32"
Overall Depth (Including Door & Handle) C	31-1/8"
Cabinet Depth D	26-3/8"
Depth (with Door 90° Open) E	59-3/8"

CERTIFICATIONS AND APPROVALS

ENERGY STAR® Qualified	Yes
Safety Certification	CSA
Sanitation Certification	NSF®

ACCESSORIES

Deep shelf (<i>Fits all except top position, white finish</i>)	216384002
Shallow top shelf (<i>Only fits top position, white finish</i>)	216386202
Trivet, white finish	216331802
Shelf support clips (<i>Sold as singles, requires 4 per shelf</i>)	297121900
Pan slide kit (<i>Includes 2 racks/4 clips, holds 8 pans 18" x 26"</i>)	PANRACKKIT
Casters, Front	297206600
Casters, Back	297206500
Caster hardware kit	297256300
Key for lock	216362800
Upright locks	216362700

Kelvinator®

USA • 10200 David Taylor Drive • Charlotte, NC 28262 • 1-866-738-1640 • kelvinator.com

CANADA • 5855 Terry Fox Way • Mississauga, ON L5V 3E4

KFS220RH 06/15

© 2015 Electrolux Home Products, Inc.

High standards of quality at Electrolux Home Products, Inc. mean we are constantly working to improve our products. We reserve the right to change specifications or discontinue models without notice.



20 CU. FT. GLASS DOOR MERCHANDISER

KGM220RH

REFRIGERATOR



Dynamic Condenser improves performance in high temperature environments

Automatic Defrost Cooling System provides worry-free performance

1/3 HP Compressor

Painted Steel Exterior & Interior

Mechanical Control

Internal Temperature Display

Adjustable Shelves Vinyl-Coated Steel

Heavy Duty Casters



Vinyl Heavy Duty Adjustable Shelves

Shelves that are easy to handle and keep clean.

NSF®-Certified Temperature

Durable and reliable for safety in food storage.

Heavy-Duty, Locking Casters

Keeps unit in place but allows position adjusting.

TECHNICAL SPECIFICATIONS

MODEL	KGM220RH
Product Line	Refrigerator
Door(s)/Type	1 Door Swing
Capacity (Cu. Ft.)	19.7
Condenser Type	Dynamic
Automatic Defrost Cooling System	Yes
Compressor Horsepower	1/3
Exterior Finish	Textured Painted Steel
Interior Finish	Smooth Painted Steel
Shelves (Number/Type)	4/Vinyl-Coated Steel
Control	Mechanical
Temperature Display Location	Internal
Temperature Range	32 to 44°F
Voltage Rating	120V/5A
Run Amps	1.3
Plug Type	NEMA 5-15P
Shipping Weight (Lbs.)	275
Warranty	3 Year/5 Year

kelvinator.com



20 CU. FT. GLASS DOOR MERCHANDISER

KGM220RH

REFRIGERATOR

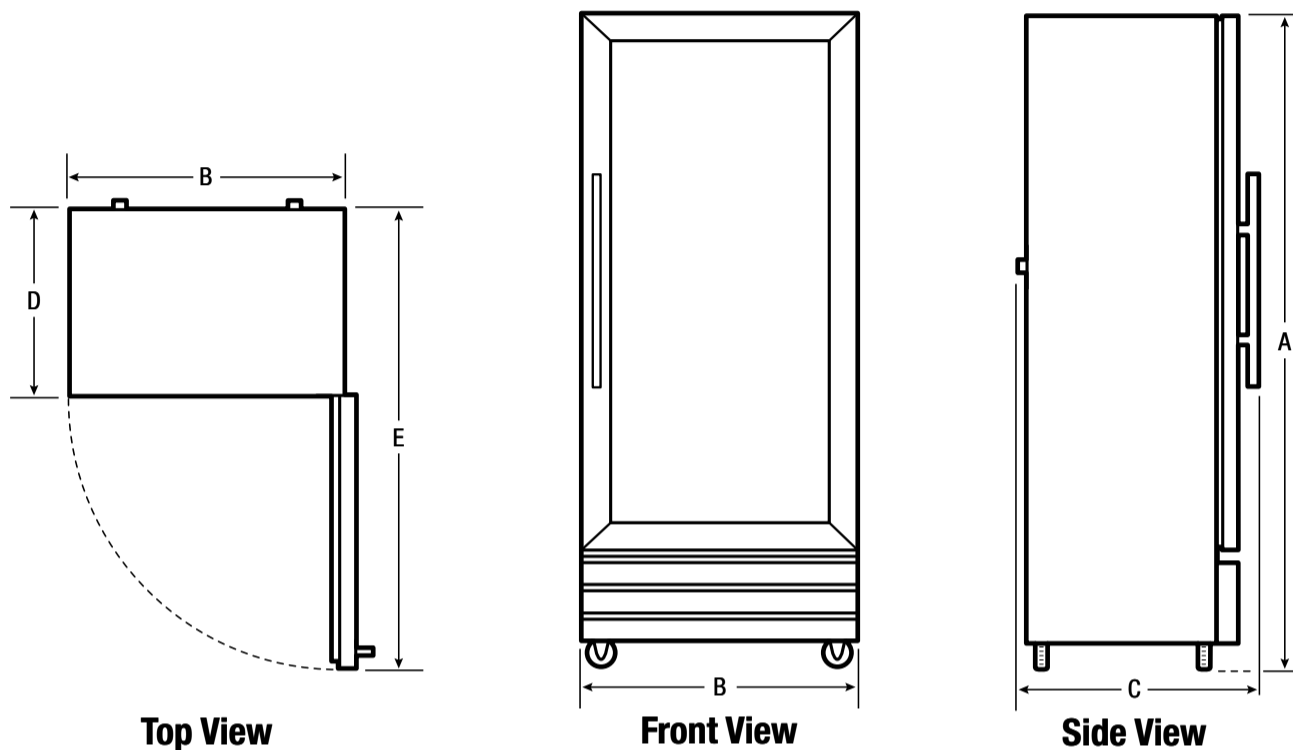

Plug Type (NEMA)
5-15P

EXTERIOR DIMENSIONS

Height A (Including Casters)	74-3/4"
Width B	32"
Overall Depth (Including Door & Handle) C	31-1/8"
Cabinet Depth D	26-3/8"
Depth (with Door 90° Open) E	59-3/8"

CERTIFICATIONS AND APPROVALS

ENERGY STAR® Qualified	Yes
Safety Certification	CSA
Sanitation Certification	NSF®

ACCESSORIES

Deep shelf, fits all except top position	216384002
Shelf support clips (Sold as singles, requires 4 per shelf)	297121900
Shallow top shelf (Only fits top position, white finish)	216386202
Trivet (White finish)	216681802



USA • 10200 David Taylor Drive • Charlotte, NC 28262 • 1-866-738-1640 • kelvinator.com
CANADA • 5855 Terry Fox Way • Mississauga, ON L5V 3E4

KGM220RH 06/15

© 2015 Electrolux Home Products, Inc.

High standards of quality at Electrolux Home Products, Inc. mean we are constantly working to improve our products. We reserve the right to change specifications or discontinue models without notice.



- Static Condenser**
- 1/5 HP Compressor**
- Painted Steel Exterior & Interior**
- Mechanical Control**
- Internal Temperature Display**
- Freezer Basket**
- Locking Lids & Key** Protect the contents of the unit
- Heavy Duty Casters**



NSF®-Certified Basket

Durable and reliable for safety in food storage.

NSF®-Certified Temperature Gauge

Durable and reliable for safety in food storage.

Heavy-Duty, Locking Casters

Keeps unit in place but allows position adjusting.

TECHNICAL SPECIFICATIONS

MODEL	KCS070G
Product Line	Chest Freezer
Capacity (Cu. Ft.)	7.2
Condenser Type	Static
Automatic Defrost Cooling System	No
Compressor Horsepower	1/5
Exterior Finish	Textured Painted Steel
Interior Finish	Painted Steel
Freezer Baskets (Number/Type)	1/Wire
Control	Mechanical
Temperature Display Location	Internal
Temperature Range	-15 to 10°F
Interior Lighting	No
Voltage Rating	120V/5A
Run Amps	1.0
Plug Type	NEMA 5-15P
Shipping Weight (Lbs.)	113
Warranty	3 Year/5 Year



7 CU. FT. CHEST FREEZER

KCS070G

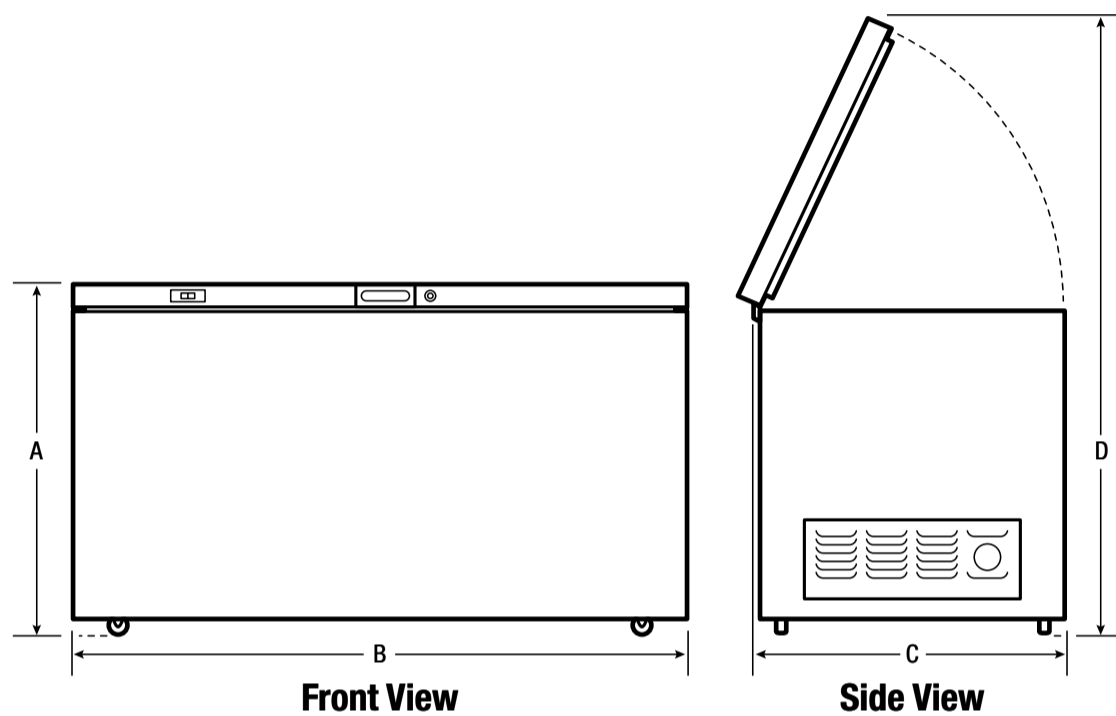

Plug Type (NEMA)
5-15P

EXTERIOR DIMENSIONS

Height A (Including Casters & Lid)	36-11/16"
Width B	35"
Cabinet Depth C	21-1/2"
Height (with Lid Open) D	55-5/16"

ACCESSORIES

Lock & Key	297090100
NSF® wire basket	297118501
Basket divider	296506200
NSF® thermometer	297070100

CERTIFICATIONS AND APPROVALS

ENERGY STAR® Qualified	Yes
Safety Certification	CSA
Sanitation Certification	NSF®

Kelvinator®

USA • 10200 David Taylor Drive • Charlotte, NC 28262 • 1-866-738-1640 • kelvinator.com

CANADA • 5855 Terry Fox Way • Mississauga, ON L5V 3E4

KCS070G 06/15

© 2015 Electrolux Home Products, Inc.

High standards of quality at Electrolux Home Products, Inc. mean we are constantly working to improve our products. We reserve the right to change specifications or discontinue models without notice.



15 CU. FT. CHEST FREEZER

KCS150L



- Static Condenser**
- 1/3 HP Compressor**
- Painted Steel Exterior & Interior**
- Mechanical Control**
- Internal Temperature Display**
- Freezer Basket**
- Locking Lids & Key** Protect the contents of the unit
- Heavy Duty Casters**
- Interior Lighting**



NSF®-Certified Basket

Durable and reliable for safety in food storage.

NSF®-Certified Temperature Gauge

Durable and reliable for safety in food storage.

Heavy-Duty, Locking Casters

Keeps unit in place but allows position adjusting.

TECHNICAL SPECIFICATIONS

MODEL	KCS150L
Product Line	Chest Freezer
Capacity (Cu. Ft.)	14.9
Condenser Type	Static
Automatic Defrost Cooling System	No
Compressor Horsepower	1/3
Exterior Finish	Textured Painted Steel
Interior Finish	Painted Steel
Freezer Baskets (Number/Type)	1/Wire
Control	Mechanical
Temperature Display Location	Internal
Temperature Range	-15 to 10°F
Interior Lighting	Yes
Voltage Rating	120V/5A
Run Amps	1.3
Plug Type	NEMA 5-15P
Shipping Weight (Lbs.)	169
Warranty	3 Year/5 Year

kelvinator.com



15 CU. FT. CHEST FREEZER

KCS150L

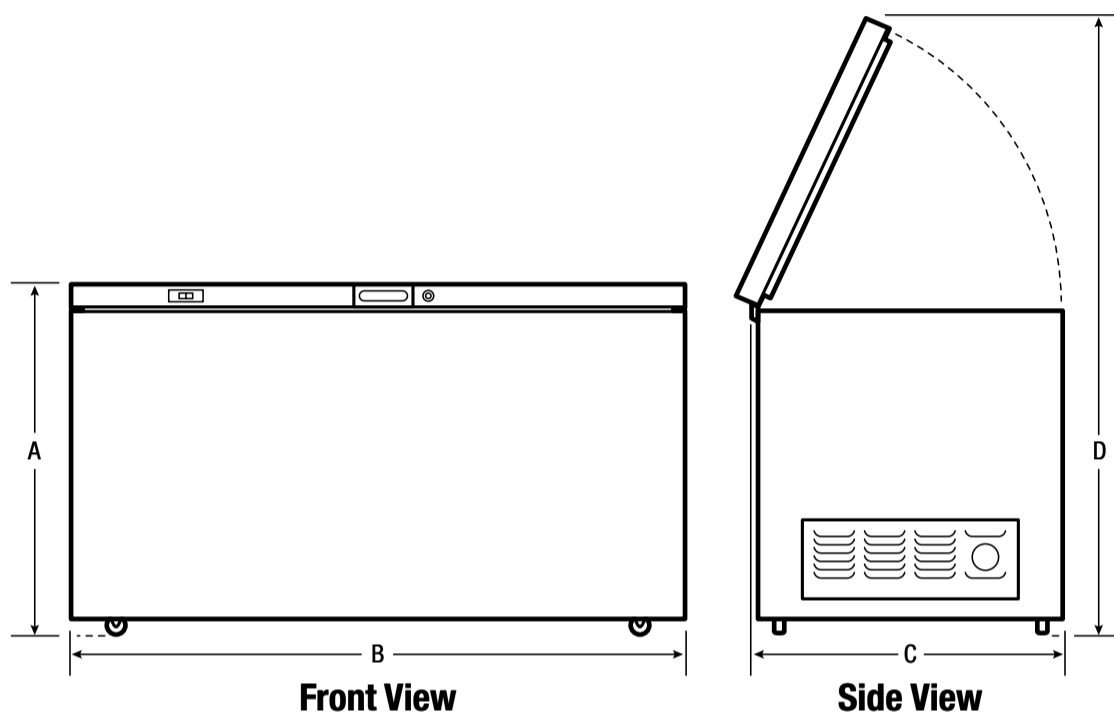

Plug Type (NEMA)
5-15P

EXTERIOR DIMENSIONS

Height A (Including Casters & Lid)	37-1/2"
Width B	48"
Cabinet Depth C	27-1/2"
Height (with Lid Open) D	60-13/16"

ACCESSORIES

Lock & Key	297090100
NSF® wire basket	297118601
Basket divider	296506200
NSF® thermometer	297070100

CERTIFICATIONS AND APPROVALS

ENERGY STAR® Qualified	Yes
Safety Certification	CSA
Sanitation Certification	NSF®

Kelvinator

USA • 10200 David Taylor Drive • Charlotte, NC 28262 • 1-866-738-1640 • kelvinator.com

CANADA • 5855 Terry Fox Way • Mississauga, ON L5V 3E4

KCS150L 06/15

© 2015 Electrolux Home Products, Inc.

High standards of quality at Electrolux Home Products, Inc. mean we are constantly working to improve our products. We reserve the right to change specifications or discontinue models without notice.



20 CU. FT. CHEST FREEZER

KCS200G



- Static Condenser**
- 1/3 HP Compressor**
- Painted Steel Exterior & Interior**
- Mechanical Control**
- Internal Temperature Display**
- Freezer Basket**
- Locking Lids & Key** Protect the contents of the unit
- Heavy Duty Casters**
- Interior Lighting**



NSF®-Certified Basket

Durable and reliable for safety in food storage.

NSF®-Certified Temperature Gauge

Durable and reliable for safety in food storage.

Heavy-Duty, Locking Casters

Keeps unit in place but allows position adjusting.

TECHNICAL SPECIFICATIONS

MODEL	KCS200G
Product Line	Chest Freezer
Capacity (Cu. Ft.)	19.9
Condenser Type	Static
Automatic Defrost Cooling System	No
Compressor Horsepower	1/3
Exterior Finish	Textured Painted Steel
Interior Finish	Painted Steel
Freezer Baskets (Number/Type)	1/Wire
Control	Mechanical
Temperature Display Location	Internal
Temperature Range	-15 to 10°F
Interior Lighting	Yes
Voltage Rating	120V/5A
Run Amps	1.3
Plug Type	NEMA 5-15P
Shipping Weight (Lbs.)	200
Warranty	3 Year/5 Year

kelvinator.com



20 CU. FT. CHEST FREEZER

KCS200G

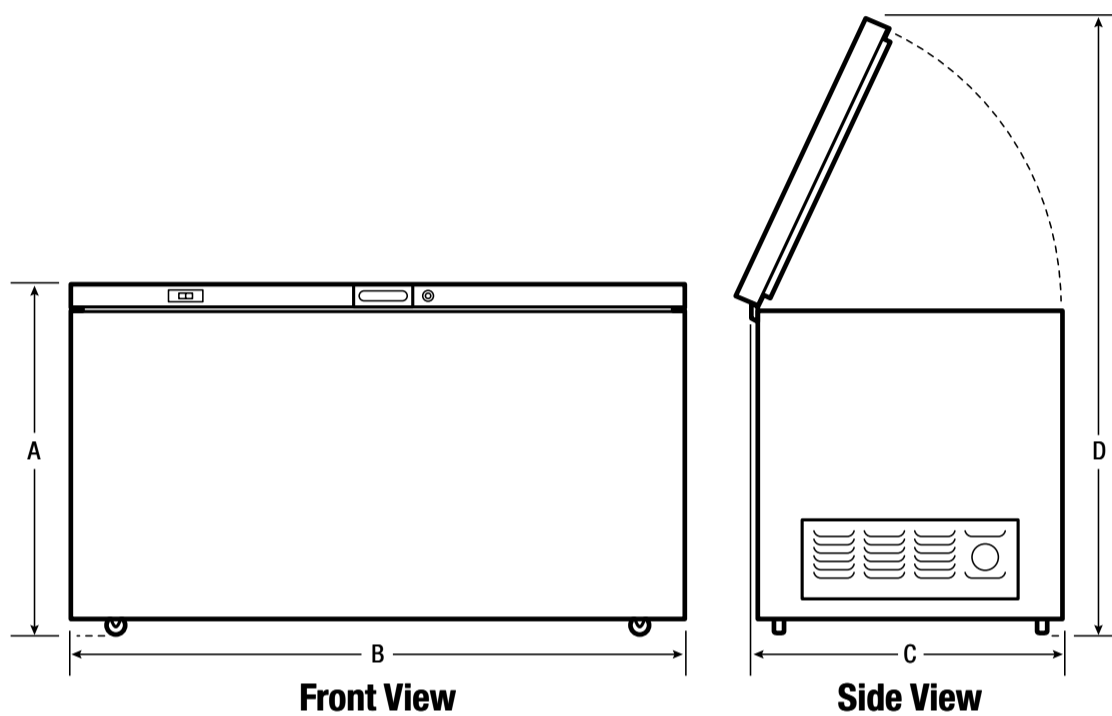

Plug Type (NEMA)
5-15P

EXTERIOR DIMENSIONS

Height A (Including Casters & Lid)	37-1/2"
Width B	61-1/4"
Cabinet Depth C	27-1/2"
Height (with Lid Open) D	60-13/16"

ACCESSORIES

Lock & Key	297090100
NSF® wire basket	297118601
Basket divider	296506200
NSF® thermometer	297070100

CERTIFICATIONS AND APPROVALS

ENERGY STAR® Qualified	Yes
Safety Certification	CSA
Sanitation Certification	NSF®

Kelvinator®

USA • 10200 David Taylor Drive • Charlotte, NC 28262 • 1-866-738-1640 • kelvinator.com

CANADA • 5855 Terry Fox Way • Mississauga, ON L5V 3E4

KCS200G 06/15

© 2015 Electrolux Home Products, Inc.

High standards of quality at Electrolux Home Products, Inc. mean we are constantly working to improve our products. We reserve the right to change specifications or discontinue models without notice.



7 CU. FT. NOVELTY FREEZER

KCG070G



Static Condenser

1/5 HP Compressor

Painted Steel Exterior & Interior

Mechanical Control

Internal Temperature Display

Freezer Basket

Locking Lids & Key Protect the contents of the unit

Heavy Duty Casters



NSF®-Certified Basket

Durable and reliable for safety in food storage.

NSF®-Certified Temperature Gauge

Durable and reliable for safety in food storage.

Heavy-Duty, Locking Casters

Keeps unit in place but allows position adjusting.

TECHNICAL SPECIFICATIONS

MODEL	KCG070G
Product Line	Novelty Freezer
Capacity (Cu. Ft.)	7.2
Condenser Type	Static
Automatic Defrost Cooling System	No
Compressor Horsepower	1/5
Exterior Finish	Textured Painted Steel
Interior Finish	Painted Steel
Freezer Baskets (Number/Type)	1/Wire
Control	Mechanical
Temperature Display Location	Internal
Temperature Range	-10 to 10°F
Voltage Rating	120V/5A
Run Amps	1.0
Plug Type	NEMA 5-15P
Shipping Weight (Lbs.)	127
Warranty	3 Year/5 Year

kelvinator.com



7 CU. FT. NOVELTY FREEZER

KCG070G

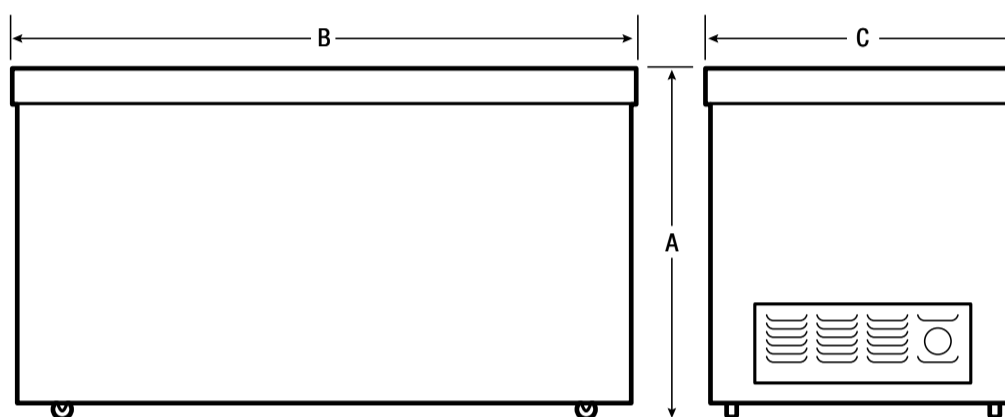

Plug Type (NEMA)
5-15P

EXTERIOR DIMENSIONS

Height A (Including Casters)	36-11/16"
Width B	35-3/4"
Cabinet Depth C	21-3/4"

ACCESSORIES

Lock Assembly	216621200
Key	297147700
NSF® wire basket	297118401
NSF® thermometer	297070100

CERTIFICATIONS AND APPROVALS

ENERGY STAR® Qualified	Yes
Safety Certification	CSA
Sanitation Certification	NSF®

Kelvinator®

USA • 10200 David Taylor Drive • Charlotte, NC 28262 • 1-866-738-1640 • kelvinator.com

CANADA • 5855 Terry Fox Way • Mississauga, ON L5V 3E4

KCG070G 06/15

© 2015 Electrolux Home Products, Inc.

High standards of quality at Electrolux Home Products, Inc. mean we are constantly working to improve our products. We reserve the right to change specifications or discontinue models without notice.



- Static Condenser**
- 1/3 HP Compressor**
- Painted Steel Exterior & Interior**
- Mechanical Control**
- Internal Temperature Display**
- Freezer Basket**
- Locking Lids & Key** protect the contents of the unit
- Heavy Duty Casters**

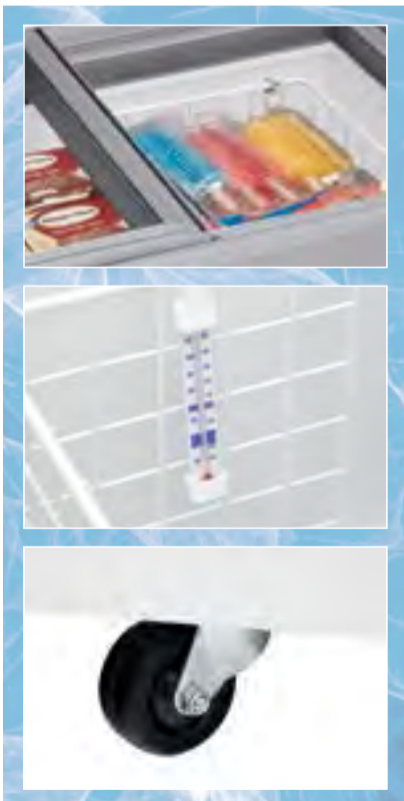

NSF®-Certified Basket
Durable and reliable for safety in food storage.

NSF®-Certified Temperature Gauge
Durable and reliable for safety in food storage.

Heavy-Duty, Locking Casters
Keeps unit in place but allows position adjusting.

TECHNICAL SPECIFICATIONS

MODEL	KCG150L
Product Line	Novelty Freezer
Capacity (Cu. Ft.)	14.8
Condenser Type	Static
Automatic Defrost Cooling System	No
Compressor Horsepower	1/3
Exterior Finish	Textured Painted Steel
Interior Finish	Painted Steel
Freezer Baskets (Number/Type)	1/Wire
Control	Mechanical
Temperature Display Location	Internal
Temperature Range	-10 to 10°F
Voltage Rating	120V/5A
Run Amps	1.3
Plug Type	NEMA 5-15P
Shipping Weight (Lbs.)	182
Warranty	3 Year/5 Year



15 CU. FT. NOVELTY FREEZER

KCG150L

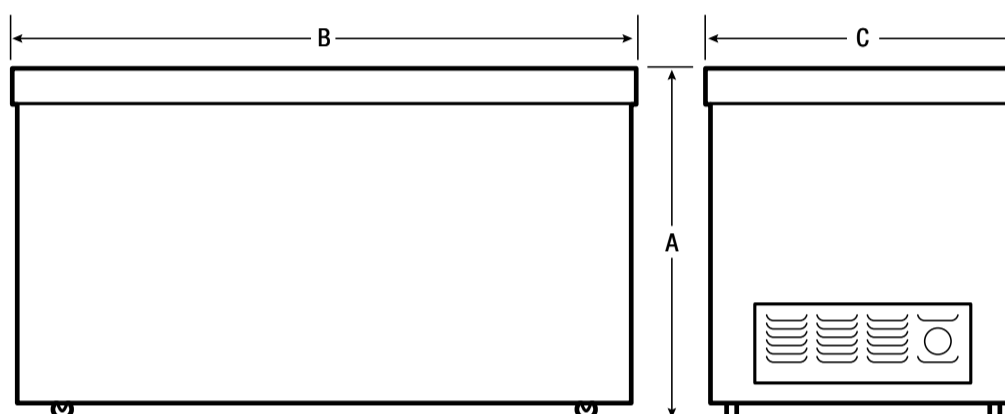

Plug Type (NEMA)
5-15P

EXTERIOR DIMENSIONS

Height A (Including Casters)	37-1/2"
Width B	48-3/4"
Cabinet Depth C	27-3/4"

ACCESSORIES

Lock Assembly	216621200
Key	297147700
NSF® wire basket	297117901
NSF® thermometer	297070100

CERTIFICATIONS AND APPROVALS

ENERGY STAR® Qualified	Yes
Safety Certification	CSA
Sanitation Certification	NSF®

Kelvinator®

USA • 10200 David Taylor Drive • Charlotte, NC 28262 • 1-866-738-1640 • kelvinator.com

CANADA • 5855 Terry Fox Way • Mississauga, ON L5V 3E4

KCG150L 06/15

© 2015 Electrolux Home Products, Inc.

High standards of quality at Electrolux Home Products, Inc. mean we are constantly working to improve our products. We reserve the right to change specifications or discontinue models without notice.



20 CU. FT. NOVELTY FREEZER

KCG200G



- Static Condenser**
- 1/3 HP Compressor**
- Painted Steel Exterior & Interior**
- Mechanical Control**
- Internal Temperature Display**
- Freezer Basket**
- Locking Lids & Key** protect the contents of the unit
- Heavy Duty Casters**



NSF®-Certified Basket

Durable and reliable for safety in food storage.

NSF®-Certified Temperature Gauge

Durable and reliable for safety in food storage.

Heavy-Duty, Locking Casters

Keeps unit in place but allows position adjusting.

TECHNICAL SPECIFICATIONS

MODEL	KCG200G
Product Line	Novelty Freezer
Capacity (Cu. Ft.)	19.8
Condenser Type	Static
Automatic Defrost Cooling System	No
Compressor Horsepower	1/3
Exterior Finish	Textured Painted Steel
Interior Finish	Painted Steel
Freezer Baskets (Number/Type)	1/Wire
Control	Mechanical
Temperature Display Location	Internal
Temperature Range	-10 to 10°F
Voltage Rating	120V/5A
Run Amps	1.3
Plug Type	NEMA 5-15P
Shipping Weight (Lbs.)	212
Warranty	3 Year/5 Year

kelvinator.com



20 CU. FT. NOVELTY FREEZER

KCG200G

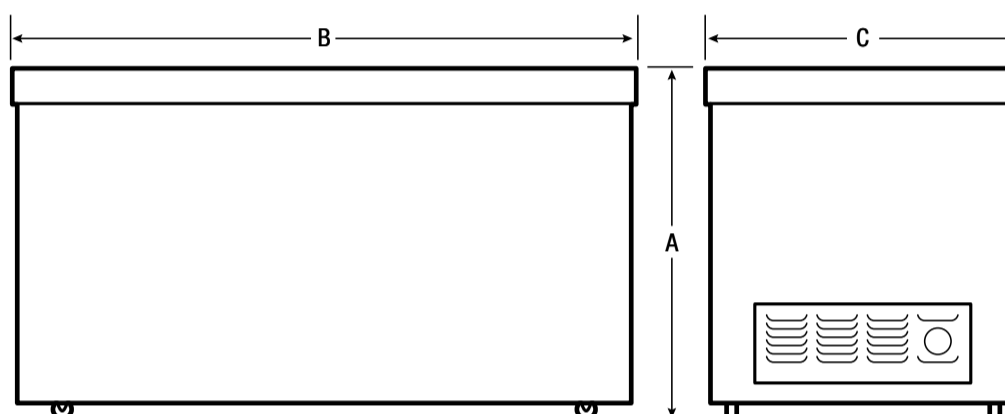

Plug Type (NEMA)
5-15P

EXTERIOR DIMENSIONS

Height A (Including Casters)	37-1/2"
Width B	62"
Cabinet Depth C	27-3/4"

ACCESSORIES

Lock Assembly	216621200
Key	297147700
NSF® wire basket	297117901
NSF® thermometer	297070100

CERTIFICATIONS AND APPROVALS

ENERGY STAR® Qualified	Yes
Safety Certification	CSA
Sanitation Certification	NSF®



USA • 10200 David Taylor Drive • Charlotte, NC 28262 • 1-866-738-1640 • kelvinator.com

CANADA • 5855 Terry Fox Way • Mississauga, ON L5V 3E4

KCG200G 06/15

© 2015 Electrolux Home Products, Inc.

High standards of quality at Electrolux Home Products, Inc. mean we are constantly working to improve our products. We reserve the right to change specifications or discontinue models without notice.

Free Manuals Download Website

<http://myh66.com>

<http://usermanuals.us>

<http://www.somanuals.com>

<http://www.4manuals.cc>

<http://www.manual-lib.com>

<http://www.404manual.com>

<http://www.luxmanual.com>

<http://aubethermostatmanual.com>

Golf course search by state

<http://golfingnear.com>

Email search by domain

<http://emailbydomain.com>

Auto manuals search

<http://auto.somanuals.com>

TV manuals search

<http://tv.somanuals.com>