

# KENWOOD

MONITOR WITH DVD RECEIVER

**DDX8019**

**DDX8039**

---

## INSTALLATION MANUAL

Kenwood Corporation

## Accessories

---

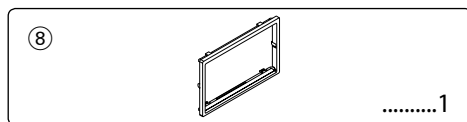
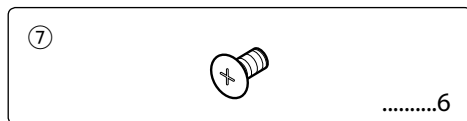
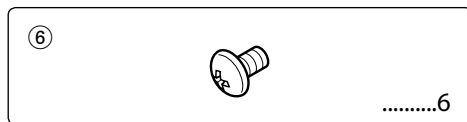
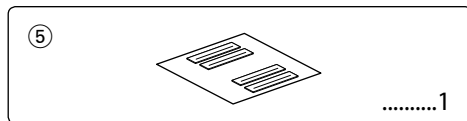
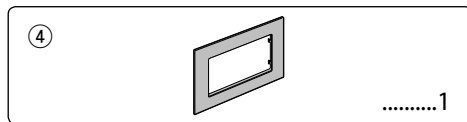
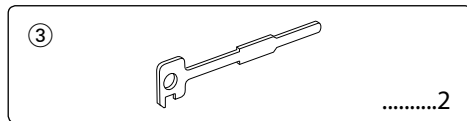
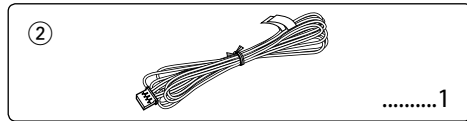
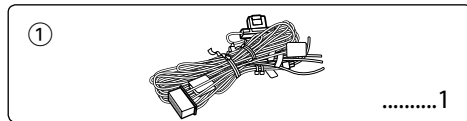

# Installation Procedure

1. To prevent a short circuit, remove the key from the ignition and disconnect the ⊖ battery.
2. Make the proper input and output wire connections for each unit.
3. Connect the speaker wires of the wiring harness.
4. Connect the wiring harness wires in the following order: ground, battery, ignition.
5. Connect the wiring harness connector to the unit.
6. Install the unit in your car.
7. Reconnect the ⊖ battery.
8. Press the reset button.

## ▲WARNING

- If you connect the ignition wire (red) and the battery wire (yellow) to the car chassis (ground), you may cause a short circuit, that in turn may start a fire. Always connect those wires to the power source running through the fuse box.
- Do not cut out the fuse from the ignition wire (red) and the battery wire (yellow). The power supply must be connected to the wires via the fuse.



- If the power is not turned ON (or it is ON, but will be OFF immediately), the speaker wire may have a short-circuit or touched the chassis of the vehicle and the protection function may have been activated. Therefore, the speaker wire should be checked.
- If your car's ignition does not have an ACC position, connect the ignition wires to a power source that can be turned on and off with the ignition key. If you connect the ignition wire to a power source with a constant voltage supply, as with battery wires, the battery may die.
- If the console has a lid, make sure to install the unit so that the faceplate will not hit the lid when closing and opening.
- If the fuse blows, first make sure the wires aren't touching to cause a short circuit, then replace the old fuse with one with the same rating.
- Insulate unconnected wires with vinyl tape or other similar material. To prevent a short circuit, do not remove the caps on the ends of the unconnected wires or the terminals.
- Connect the speaker wires correctly to the terminals to which they correspond. The unit may be damaged or fail to work if you share the ⊖ wires or ground them to any metal part in the car.
- When only two speakers are being connected to the system, connect the connectors either to both the front output terminals or to both the rear output terminals (do not mix front and rear). For example, if you connect the ⊕ connector of the left speaker to a front output terminal, do not connect the ⊖ connector to a rear output terminal.
- After the unit is installed, check whether the brake lamps, blinkers, wipers, etc. on the car are working properly.
- Mount the unit so that the mounting angle is 30° or less.
- This unit has the cooling fan (page 5) to decrease the internal temperature. Do not mount the unit in a place where the cooling fan of the unit are blocked. Blocking these openings will inhibit the cooling of the internal temperature and result in malfunction.

# Connection

**⚠** If you connect the ignition wire (red) and the battery wire (yellow) to the car chassis (ground), you may cause a short circuit, that in turn may start a fire. Always connect those wires to the power source running through the fuse box.

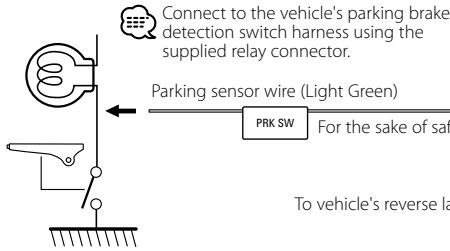
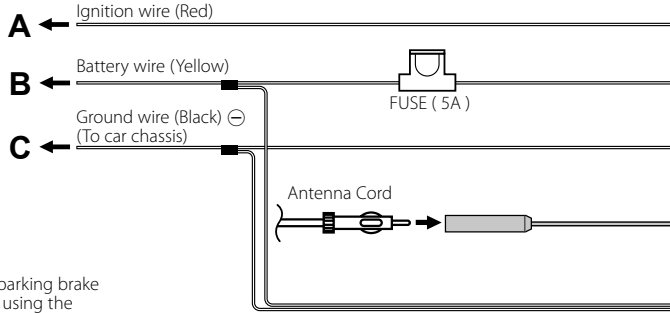
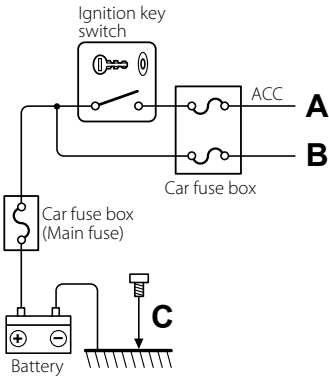

For the sake of safety, be sure to connect the parking sensor.

To vehicle's reverse lamp harness — Reverse sensor wire (Purple/White)

To car light control switch — Dimmer control wire (Orange/White)

To steering remote — Steering remote control input (Light Blue/Yellow)

Connect to the terminal that is grounded when either the telephone rings or during conversation. — Mute wire (Brown)

To connect the Kenwood navigation system, consult your navigation manual.

Depending on what antenna you are using, connect either to the control terminal of the motor antenna, or to the power terminal for the booster amplifier of the film-type antenna. — Motor antenna control wire (Blue)

When using the optional power amplifier, connect to its power control terminal. — Power control wire (Blue/White)

To "EXT.AMPCONT" terminal of the amplifier having the external amp control function. — External amplifier control wire (Pink/Black)

**⚠** If no connections are made, do not let the cable come out from the tab.

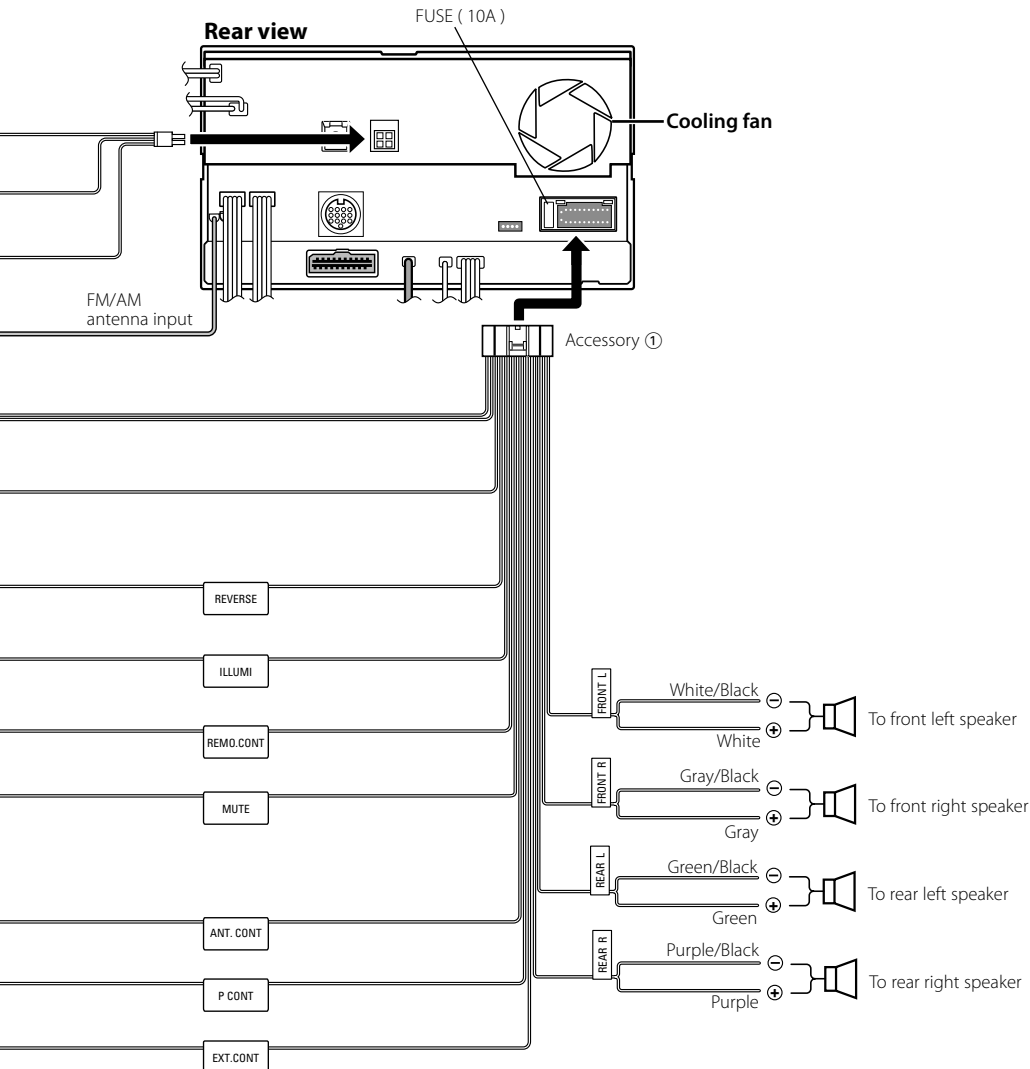

# System Connection

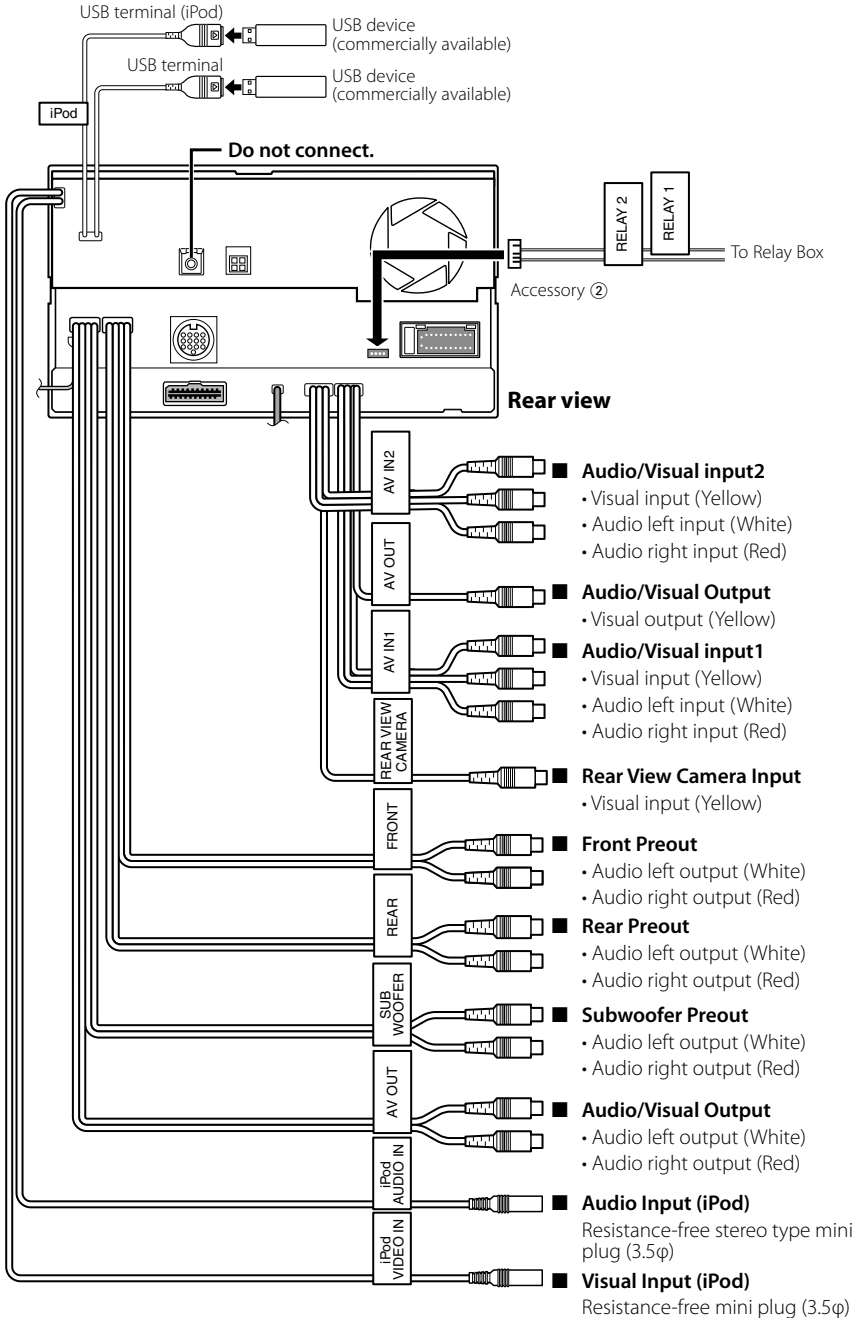

# Optional Accessory Connection

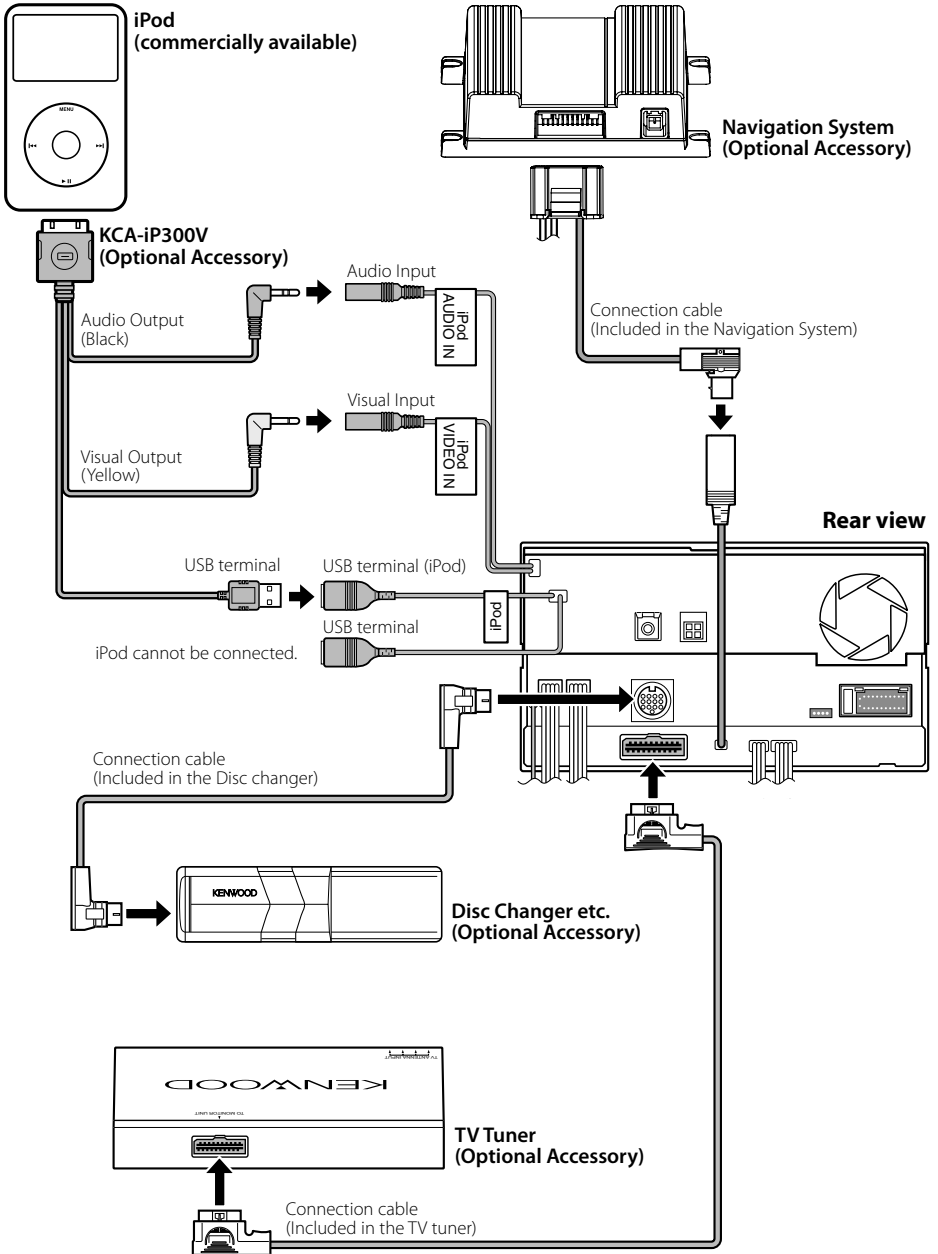

# Installing the Escutcheon

---

## For General Motors

---

1. Cut out accessory ④ to meet the shape of the opening of the center console.
2. Attach accessory ④ to the unit.

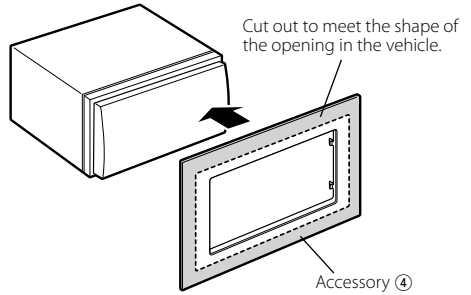

## For Volkswagen

---

1. Attach accessory ⑧ to the unit.

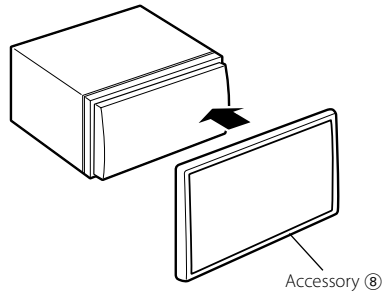



## For Toyota/Scion

1. Cut out accessory ④ as illustrated.

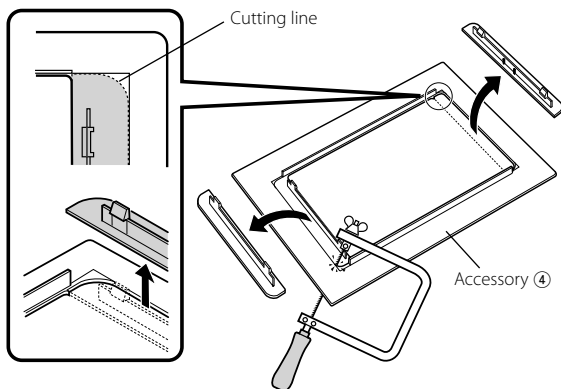

2. Fold double-sided adhesive (accessory ⑤) along the slit and attach it to accessory ④ cut-out against the center rib as illustrated. Use 2 pieces of accessory ⑤ for 1 accessory ④ cut-out.

3. Attach accessory ④ cut-out to the unit.

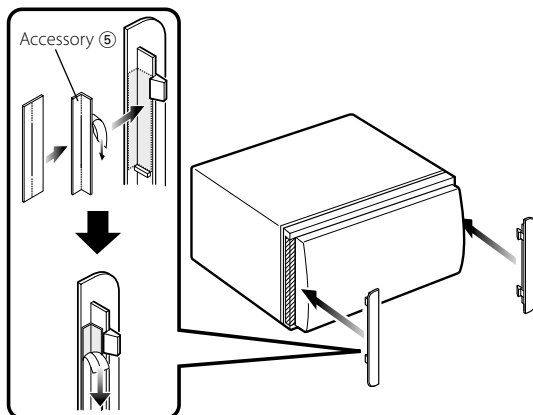

## Installation for Monitor/Player Unit

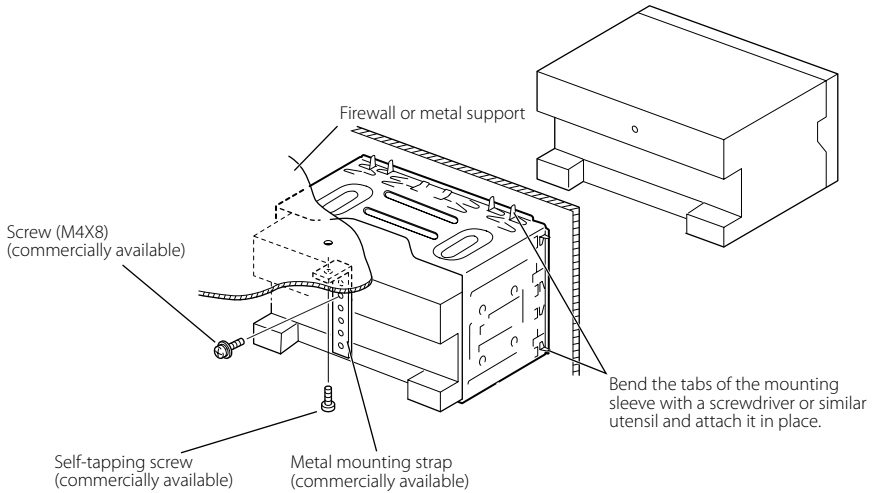

Make sure that the unit is installed securely in place. If the unit is unstable, it may malfunction (eg, the sound may skip).

## Installation on Toyota, Nissan or Mitsubishi Car using Brackets

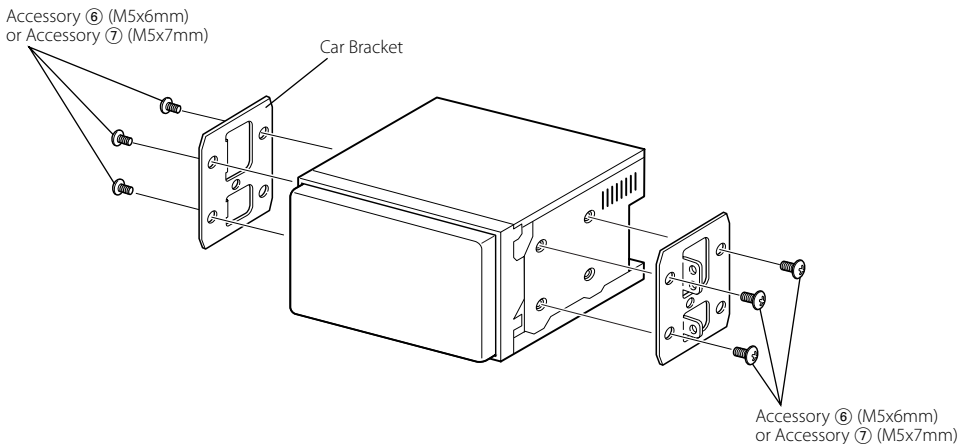

# Removing Monitor/Player Unit

## Removing the Hard Rubber Frame (escutcheon)

1. Engage the catch pins on the removal tool ③ and remove the two locks on the lower level. Lower the frame and pull it forward as shown in the figure.

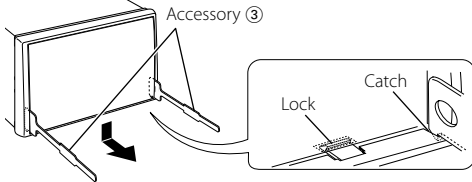

- The frame can be removed from the top side in the same manner.

2. When the lower level is removed, remove the upper two locations.

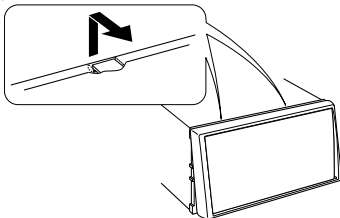

## Removing the Unit

1. Remove the hard rubber frame by referring to the removal procedure in the section <Removing the Hard Rubber Frame>.
2. Remove the Hex-head screw with integral washer (M4 x 8) on the back panel.
3. Insert the two removal tools ③ deeply into the slots on each side, as shown.

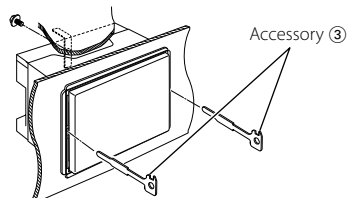

4. Lower the removal tool toward the bottom, and pull out the unit halfway while pressing towards the inside.

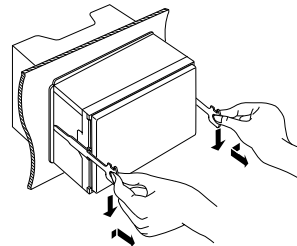

- Be careful to avoid injury from the catch pins on the removal tool.

5. Pull the unit all the way out with your hands, being careful not to drop it.

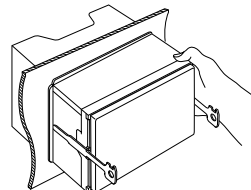



## Free Manuals Download Website

<http://myh66.com>

<http://usermanuals.us>

<http://www.somanuals.com>

<http://www.4manuals.cc>

<http://www.manual-lib.com>

<http://www.404manual.com>

<http://www.luxmanual.com>

<http://aubethermostatmanual.com>

Golf course search by state

<http://golfingnear.com>

Email search by domain

<http://emailbydomain.com>

Auto manuals search

<http://auto.somanuals.com>

TV manuals search

<http://tv.somanuals.com>