

KENWOOD

KAC-X811D **KAC-PS811D**

SUBWOOFER POWER AMPLIFIER ► page 2-9

INSTRUCTION MANUAL

KENWOOD CORPORATION

Safety precautions

▲WARNING

To prevent injury or fire, take the following precautions:

- When extending the ignition, battery, or ground wires, make sure to use automotive-grade wires or other wires with a 8 mm² (AWG 8) or more to prevent wire deterioration and damage to the wire coating.
- To prevent a short circuit, never put or leave any metallic objects (such as coins or metal tools) inside the unit.
- If the unit starts to emit smoke or strange smells, turn off the power immediately and consult your Kenwood dealer.
- Do not touch the unit during use because the surface of the unit becomes hot and may cause burns if touched.

▲CAUTION

To prevent damage to the machine, take the following precautions:

- Be sure the unit is connected to a 12V DC power supply with a negative ground connection.
- Do not open the top or bottom covers of the unit.
- Do not install the unit in a spot exposed to direct sunlight or excessive heat or humidity. Also avoid places with too much dust or the possibility of water splashing.
- When replacing a fuse, only use a new one with the prescribed rating. Using a fuse with the wrong rating may cause your unit to malfunction.
- To prevent a short circuit when replacing a fuse, first disconnect the wiring harness.

Available Control Units:

A KENWOOD's LX-Bus supporting Center Unit released in 2004 or later can control this unit. The operations of the (LX) AMP Control are explained in the Operation Manual of the Center Unit.

NOTE

- The LX AMP and the sensor unit cannot be connected simultaneously. You must connect any of them at a time.

NOTE

- If you experience problems during installation, consult your Kenwood dealer.
- If the unit does not seem to be working right, consult your Kenwood dealer.

Cleaning the unit

If the front panel gets dirty, turn off the power and wipe the panel with a dry silicon cloth or soft cloth.

▲CAUTION

Do not wipe the panel with a hard cloth or a cloth dampened by volatile solvents such as paint thinner and alcohol. They can scratch the surface of the panel and/or cause the indicator letters to peel off.

To prevent battery rise

When the unit is used in the ACC ON position without turning the engine ON, it depletes the battery. Use it after starting the engine.

Protection function

There is a Protection function installed in the unit to protect the unit and speakers from various problems. When Protection operates, the display informs you of the condition.

Display	Informations
"E-01"	When the inside of the unit is overheating.
"E-02"	When the unit has failed and direct current voltage is generated to the speaker's output. NOTE Turn the power OFF and release the protection. If the "E-02" code does not disappear, contact your Kenwood dealer.
"E-03"	When the speaker cord is shorted. When the speaker output is in contact with the vehicle ground.
"VOLT" display is blinked.	When voltage gets out of operation range.

Wiring

- Take the battery wire for this unit directly from the battery. If it's connected to the vehicle's wiring harness, it can cause blown fuses etc.
- If a buzzing noise is heard from the speakers when the engine is running, connect a line noise filter (optional) to each of the battery wire.
- Do not allow the wire to directly contact the edge of the iron plate by using Grommets.
- Connect the ground wire to a metal part of the car chassis that acts as an electrical ground passing electricity to the battery's negative ⊖ terminal. Do not turn the power on if the ground wire is not connected.
- Be sure to install a protective fuse in the power cord near the battery. The protective fuse should be the same capacity as the unit's fuse capacity or somewhat larger.
- For the power cord and ground, use a vehicle type (fireproof) power wiring cord with a current capacity greater than the unit's fuse capacity. (Use a power wiring cord with a diameter of 8 mm² (AWG 8) or greater.)
- When more than one power amplifier are going to be used, use a power supply wiring wire and protective fuse of greater current-handling capacity than the total maximum current drawn by each amplifier.

Speaker Selection

- The rated input power of the speakers that are going to be connected should be greater than the maximum output power (in Watts) of the amplifier. Use of speakers having input power ratings that are less than the output power of the amplifier will cause smoke to be emitted as well as damage.
- Use speakers that have an impedance of 1Ω or greater. When more than one set of speakers are going to be used, calculate the combined impedance of the speakers and then connect suitable speakers to the amplifier.

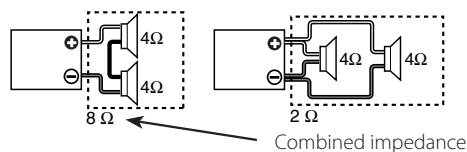

Installation

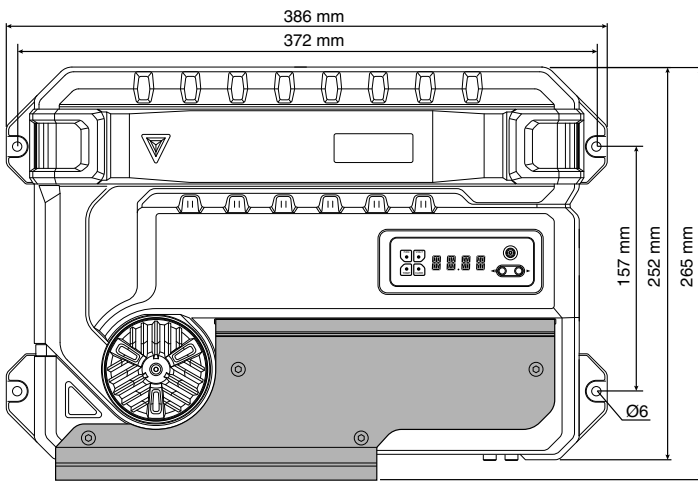

Accessories

Part name	External View	Number of Items
Self-tapping screws (ø5 × 18 mm)		4
Hexagon socket head cap screw (M4 × 8 mm)		4
Cover		1
Terminal cover (Power terminal)		1
Hexagon Wrench		1

Installation procedure

Since there are large variety of settings and connections possible according to applications, read the instruction manual well to select the proper setting and connection.

1. Remove the ignition key and disconnect the negative \ominus terminal of the battery to prevent short circuits.
2. Set the unit according to the intended usage.
3. Connect the input and output wires of the units.
4. Connect the speaker wires.
5. Connect the power wire, power control wire and grounding wire following this order.
6. Install the installation fittings in the unit.
7. Attach the unit.
8. Install the terminal cover.
9. Connect the negative \ominus terminal of the battery.

CAUTION

- Do not install in the below locations; (Unstable location, In a location that interferes with driving, In a location that gets wet, In a dusty location, In a place that gets hot, In a place that gets direct sunlight, In a location that gets hit by hot air)
- Do not install the unit under the carpet. Otherwise heat build-up occurs and the unit may be damaged.
- Install this unit in a location which allows heat to easily dissipate. Once installed, do not place any object on top of the unit.
- The surface temperature of the amplifier will become hot during use. Install the amplifier in a place where people, resins, and other substances that are sensitive to heat will not come into contact with it.
- This unit has cooling fan to decrease the internal temperature. Do not mount the unit in a place where the cooling fan and ducts of the unit are blocked. Blocking these openings will inhibit the cooling of the internal temperature and result in malfunction.
- When making a hole under a seat, inside the trunk, or somewhere else in the vehicle, check that there is nothing hazardous on the opposite side such as a gasoline tank, brake pipe, or wiring harness, and be careful not to cause scratches or other damage.
- Do not install near the dashboard, rear tray, or air bag safety parts.
- The installation to the vehicle should securely fasten the unit to a place in which it will not obstruct driving. If the unit comes off due to a shock and hits a person or safety part, it may cause injury or an accident.
- After installing the unit, check to make sure that electrical equipment such as the brake lamps, turn signal lamps and windshield wipers operate normally.

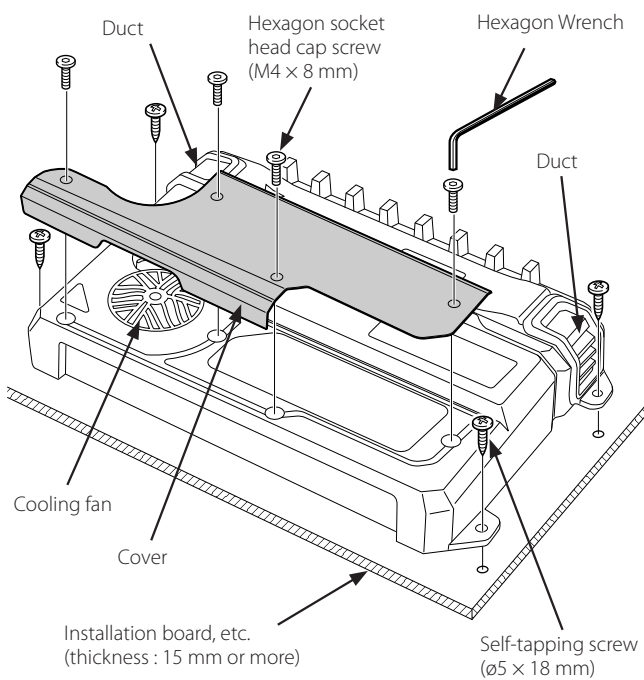

▲WARNING

To prevent fire caused by a short in the wiring, connect a fusible link or breaker nearby the battery's positive terminal.

▲CAUTION

- If sound is not output normally, immediately turn power off and check connections.
- Be sure to turn the power off before changing the setting of any switch.
- If the fuse blows, check wires for shorts, then replace the fuse with one of the same rating.
- Check that no unconnected wires or connectors are touching the car body. Do not remove caps from unconnected wires or connectors to prevent short circuits.
- Connect the speaker wires to appropriate speaker connectors separately. Sharing the negative wire of the speaker or grounding speaker wires to the metal body of the car can cause this unit to fail.
- After installation, check that the brake lamps, wipers, and wipers work properly.

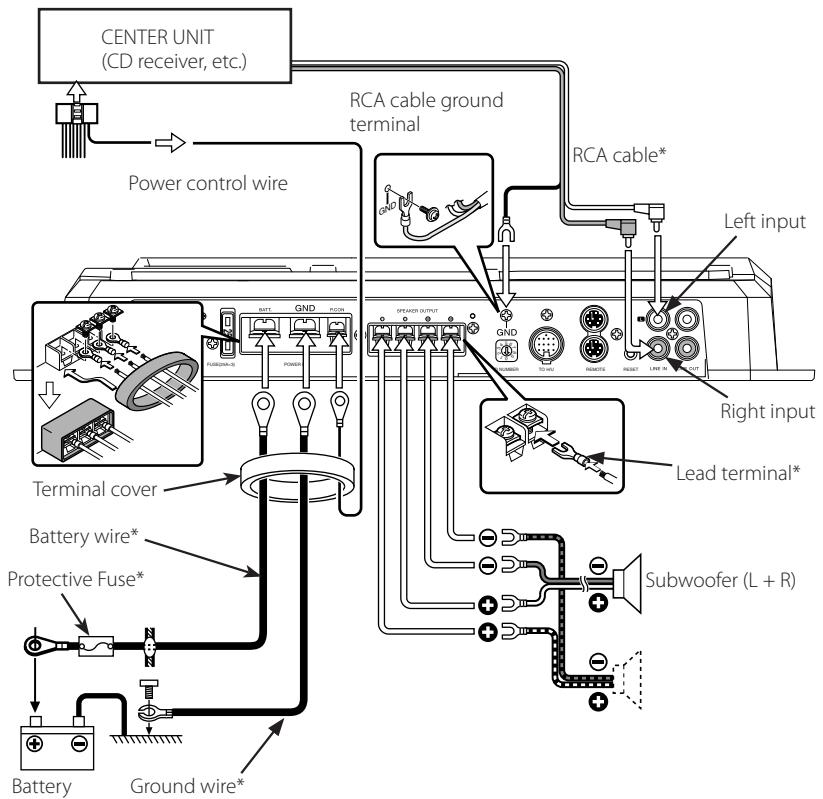

■ LX-Bus connection

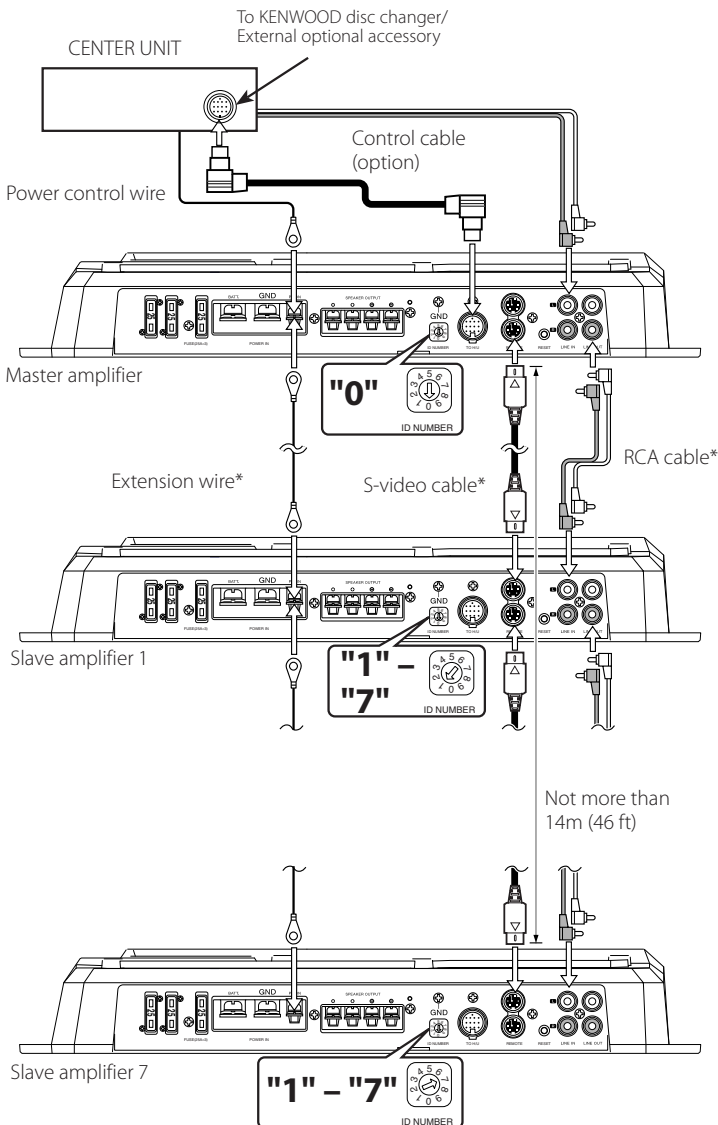

Set the ID number of the Master amplifier to "0". You can connect up to 7 Slave amplifiers. Assign them ID numbers "1" to "7" and do not duplicate them.

▲CAUTION

- Do not connect 2 Master amplifiers to the Center Unit. If done, you cannot control all amplifiers connected to the Center Unit.
- The LX AMP and the sensor unit cannot be connected simultaneously. You must connect any of them at a time.

NOTE

- The total length of S-video cables you can connect is 14 meters (46 ft) maximum. If the cable length exceeds this limit, you cannot control amps from the Center Unit.
- If you assign the same ID number to multiple amplifiers, they malfunction when you operate any of them from the Center Unit.
- If you assign ID number "8" or "9" to a Slave amplifier, it is not recognized by the Center Unit.

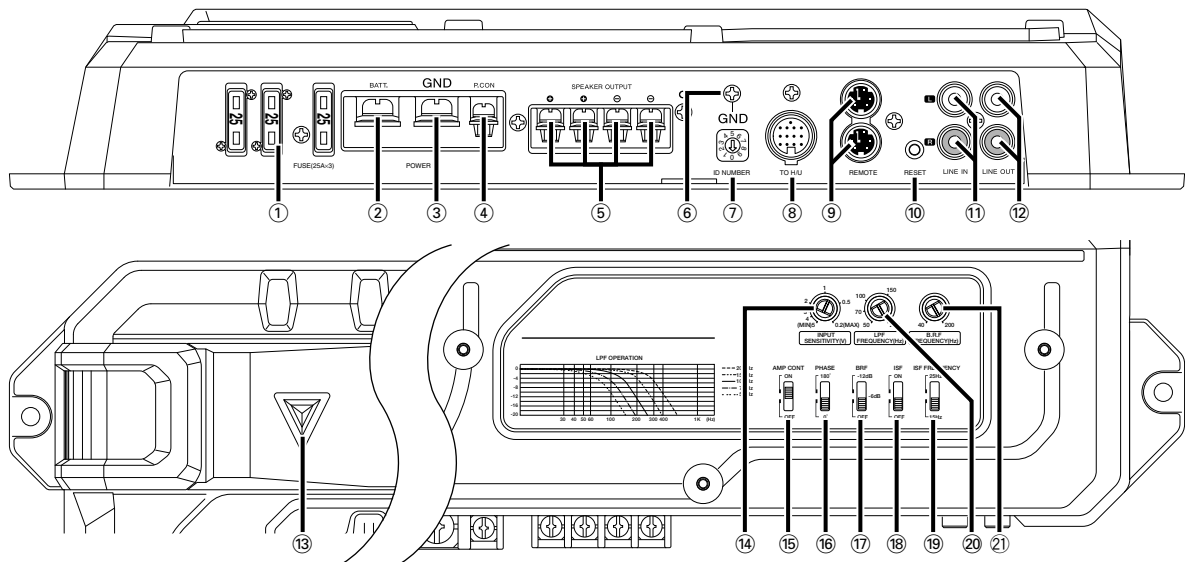

① **Fuse (25 A × 3)**

② **Battery terminal**

③ **Ground terminal**

④ **Power control terminal**

Controls the unit ON/OFF.

NOTE

Controls the unit power. Be sure to connect it with all the systems.

⑤ **Speaker output terminals**

As this unit accepts speakers with a minimum impedance of 1 ohm, connect speakers with 1-ohm or higher impedance to these terminals.

CAUTION

The rated input of the speakers should be no less than the maximum output of the amplifier. Otherwise malfunction may result.

⑥ **RCA cable ground lead terminal**

When using an RCA cable with a ground lead attached, connect the ground lead to this terminal.

⑦ **ID NUMBER switch**

Sets an amp identification number (ID) to be used for amplifier control from the Center Unit. Assign ID Number "0" to an amplifier when you use it as the Master amplifier. Assign ID Numbers "1" to "7" to amplifiers when you use them as Slave amplifiers. Do not duplicate these numbers.

NOTE

After you have changed ID numbers of amplifiers, turn Off the POWER switch of the Center Unit and turn it On again.

⑧ **TO H/U terminal**

After you have set the Master amplifier, connect it to the Center Unit.

⑨ **REMOTE terminals**

Used to connect to Slave amplifiers.

⑩ **RESET button**

Resets the microprocessor of the unit.

NOTE

The values you have set with the Amplifier Control are NOT reset.

⑪ **LINE IN terminal**

⑫ **LINE OUT terminal**

The signal that's input from the line input terminal is output.

⑬ **Power indicator**

Lights when the POWER switch is turned On.

The indicator flashes several seconds when the POWER switch is turned On or when the Protection function is activated.

⑭ **INPUT SENSITIVITY control**

Set this control according to the pre-output level of the center unit connected with this unit.

NOTE

For the pre-output level, refer to the "Specifications" in the instruction manual of the center unit.

⑮ **AMP CONT (amplifier control) switch**

Used to bypass the circuit when you do not control the sound with the Amplifier Control.

• **ON position:**

Allows you to control the sound with the Amplifier Control.

• **OFF position:**

Bypasses the Amplifier Control circuit.

NOTE

Amplifier control is possible even while OFF.

⑯ **PHASE switch**

When this switch is set "180°" (Reverse) the speaker output phase is reversed.

⑰ **BRF (band reject filter) switch**

When this switch is set to "-6dB"/"-12dB", frequencies in the band set with the "B.R.F. FREQUENCY" control are rejected and eliminated. The band rejection allows to reduce resonance inside the vehicle compartment and standing waves. (page 8)

⑱ **ISF (infrasonic filter) switch**

When this switch is set to "ON", the inaudible, ultralow frequencies below the frequency set with the "ISF FREQUENCY" switch are cut off. This improves the reproduction performance of the speakers by eliminating unnecessary oscillations which will not become sound.

⑲ **ISF FREQUENCY switch**

Switches the cutoff frequency when the "ISF" switch is set to "ON".

⑳ **LPF (Low-Pass Filter) FREQUENCY control**

This control adjusts the frequency band output from this unit.

㉑ **B.R.F. FREQUENCY control**

Sets the rejection frequency when the "BRF" switch is set to "-6dB"/"-12dB". (page 8)

Amplifier Control System

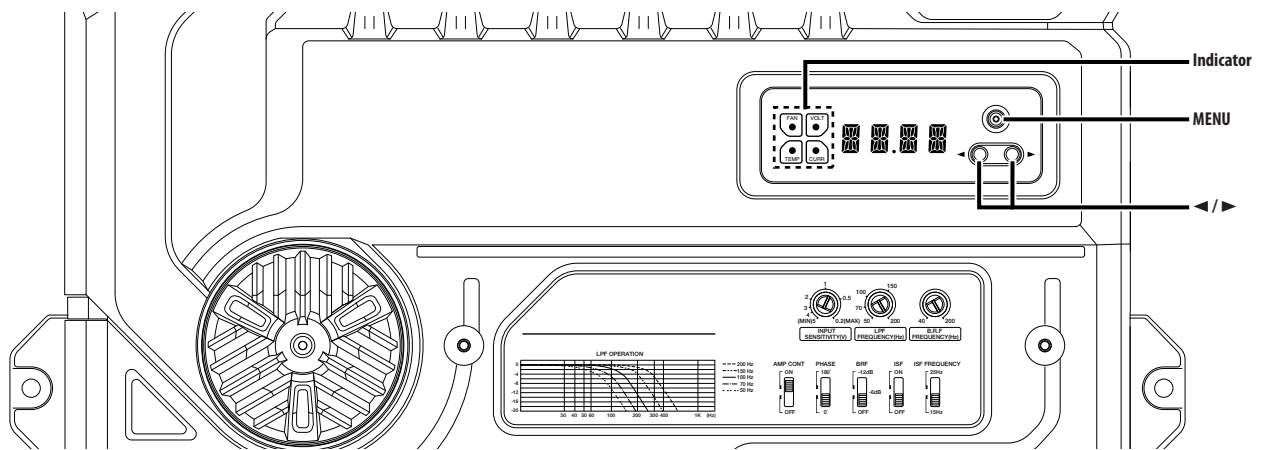

Display mode

You can set up the display items as follows:

1 Enter Menu mode

Press the [MENU] button.

"VOLT"/"CURR"/"TEMP"/"FAN" is displayed.

2 Select a display item

Press the [◀] or [▶] button.

The display items are switched in the following sequence.

Display	Information
"VOLT"	Indicates the source voltage (V).
"CURR"	Indicates the current consumption (A).
"TEMP"	Indicates the internal temperature (°F/°C).
"FAN"	Indicates the rotation speed of the cooling fan in 3 steps: "FAST", "SLOW" or "OFF".

3 Exit Menu mode

Press the [MENU] button for at least 1 second.

NOTE

When the internal temperature is -22°F/-30°C or less, "-22F"/"-30C" is displayed.

Separate Amp Control

You can control sounds using the Amplifier Control function of the unit.

1 Enter Menu mode

Press the [MENU] button.

2 Select the Menu item

Press the [MENU] button.

The setup items are displayed approximately 1 second first, then the set values are displayed.

3 Adjust the Menu item

Press the [◀] or [▶] button.

The setup items and set values are switched as follows.

Display	Range	Adjustment Item
"VOLT"/"CURR"/"TEMP"/"FAN"		For the operation method refer to 'Display mode'
"BASS"	60/80/100/200 (Hz)	Bass Center Frequency
"BA G"	B-15 — B+15 (dB)	Bass level
"BA Q"	Q1.00/Q1.25/Q1.50/Q2.00	Bass Q Factor
"EXT"	ON/OFF	When the bass extend is set to ON, low frequency response is extended by 20%.
"VOL"	-20 — 0 (dB)	Volume offset
"TEMP"	FAHR (Fahrenheit) or CELS (Centigrade)	The Fahrenheit or Centigrade temperature unit can be selected for the Display mode.
"DEFA"		For the operation method refer to 'Default'
"AMP"	0 — 7	The ID Number you have assigned is displayed.

4 Exit Menu mode

Press the [MENU] button for at least 1 second.

NOTE

When you hold down the [▶] button 3 or more seconds during ID number display ("AMP"), message "MEMO" is displayed and you can register the values you have set with the Amplifier Control. To call the Amplifier Control's values, hold down the [◀] button 3 or more seconds during ID number display ("AMP"). Then, you can recall the value when message "LOAD" is displayed.

Default

Resets all values you have set to the initial (default) values.

1 Enter Menu mode

Press the [MENU] button.

2 Select Default mode

Press the [MENU] button.

Select the "DEFA" display.

3 Resets the value to its default

Press the [▶] button for at least 2 seconds.

Message "----" is displayed, and the value is initialized.

4 Exit Menu mode

Press the [MENU] button for at least 1 second.

NOTE

Volume offset value can not be initialized.

Display Demonstration

The "VOLT"/"CURR"/"TEMP"/"FAN" items are displayed repeatedly.

Press the [MENU] button for at least 2 seconds.

The indicator flashes in the Demonstration mode.

Canceling the Demonstration mode

Press any button to cancel the Demonstration mode.

Control an Amp from Center Unit

You can control the sound by controlling amplifiers from the Center Unit.

1 Enter AMP Control mode

Select the AMP Control mode by following the 'AMP Control' procedure given on the Operation Manual of the Center Unit.

NOTE

Use the set item and value operation buttons by following the instructions given on the Operation Manual of the Center Unit.

2 Select an amp number to operate

Operate the desired set item with the Center Unit.

Select the "AMP NO"/"AMP CONTROL NO" display.

NOTE

When the Center Unit is in the STANDBY mode, message "AMP OFF" is displayed and you cannot operate the set items.

3 Set an ID number of Amp to operate

Set an amp's ID number on the Center Unit.

You can select an ID number of "0" to "7" of connected amps.

4 Select the AMP Control item for adjustment

Select the desired set item on the Center Unit.

5 Adjust the AMP Control item

You can set a value of each item on the Center Unit.

The set items and their values are switched and displayed as follows.

Display	Range	Adjustment Item
"VOLT"/"CURR"/"TEMP"/"FAN"		The amp state is displayed.
"VOLT"		Indicates the source voltage (V).
"CURR"		Indicates the current consumption (A).
"TEMP"		Indicates the internal temperature (°F/°C).
"FAN"		Indicates the rotation speed of the cooling fan in 3 steps: "FAST", "SLOW" or "OFF".
"BAS F"/"BASS FREQ"	60/80/100/200 (Hz)	Bass Center Frequency
"BAS G"/"BASS GAIN"	-15 — +15 (dB)	Bass level
"Q FA"/"Q FACTOR"	Q1.00/Q1.25/Q1.50/Q2.00	Bass Q Factor
"EXT"/"BASS EXT"	ON/OFF	When the bass extend is set to ON, low frequency response is extended by 20%.
"VOL"/"VOL OFFSET"	-20 — 0 (dB)	Volume offset
"AMP NO"/ "AMP CONTROL NO"	0 — 7	Select an ID number of the amp you use.

6 Exit AMP Control mode

Releases the Amp Control mode by the Center Unit.

NOTE

When you have controlled the bass or treble of the sound using the Equalizer or DSP function of the Center Unit, and when you amplify the same frequency as that controlled by the Amplifier Control, the sound may be distorted due to an input overflow.

Messages that may be displayed on the Center Unit

When you are selecting an item with the Amp Control, an error status of the amplifier is displayed on the Center Unit.

Display	Informations
"AMP × E-01"/"AMP × COND E-01"	When the inside of the unit is overheating. When the unit has failed and direct current voltage is generated to the speaker's output.
"AMP × E-02"/"AMP × COND E-02"	NOTE Turn the POWER switch Off and release the protection. If the error message continues, consult to the KENWOOD's dealership.
"AMP × E-03"/"AMP × COND E-03"	When the speaker cord is shorted. When the speaker output is in contact with the vehicle ground.
"AMP OFF"	When you use the Amp Control in the Standby mode.

NOTE

Number "x" on the display indicates the amp's ID number.

Band Reject Filter

The acoustic properties of vehicle compartment tend to cause oscillation due to resonance or unclearness of sound due to standing waves at certain frequencies. The band reject filter can solve the problems of resonance or unclear sound with minimum influence on the sound quality because it eliminates only the frequencies causing resonance or standing waves.

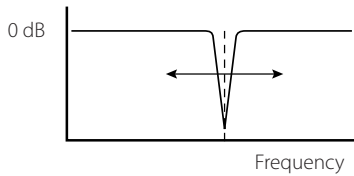

■ Adjustment method:

The band reject filter cuts only the limited frequencies to minimize influence on the sound quality. Therefore, its effect cannot be obtained unless the cutoff frequencies are set accurately to the frequencies causing resonance and standing waves. The band reject filter can be adjusted according to what you feel through your ears, but we recommend the use of a signal generator or a spectrum analyzer with a fine frequency measurement capability for the adjustment.

• Adjustment using a signal generator:

Output a sine wave, vary its frequency to find the frequencies at which the vehicle compartment resonates or volume increases (standing waves occur), and set the B.R.F. FREQUENCY control to the position with which the resonance and standing waves disappear.

• Adjustment using a spectrum analyzer:

Output white noise (sound in which all frequencies are at a certain level), find the peak frequency observed on the spectrum analyzer, and set the B.R.F. FREQUENCY control to the position with which the peak observed on the spectrum analyzer disappears.

Troubleshooting Guide

What might appear to be a malfunction in your unit may just be the result of slight misoperation or miswiring. Before calling service, first check the following table for possible problems.

PROBLEM	POSSIBLE CAUSE	SOLUTION
No sound. (Blown fuse.)	<ul style="list-style-type: none"> Input (or output) cables are disconnected. Protection circuit may be activated. Volume is too high. The speaker cord is shorted. 	<ul style="list-style-type: none"> Connect the input (or output) cables. Check connections by referring to "Protection function". Replace the fuse and use lower volume. After check the speaker cord and fixing the cause of the short, replace the fuse.
The output level is too small (or too large).	<ul style="list-style-type: none"> The input sensitivity adjusting control is not set to the correct position. 	<ul style="list-style-type: none"> Adjust the control correctly referring to "Controls".
The sound quality is bad. (The sound is distorted.)	<ul style="list-style-type: none"> The speakers wire are connected with wrong \oplus / \ominus polarity. A speaker wire is pinched by a screw in the car body. The switches may be set improperly. 	<ul style="list-style-type: none"> Connect them properly checking the \oplus / \ominus of the terminals and wires well. Connect the speaker wire again so that it is not pinched by anything. Set switches properly by referring to "Controls".
The sound does not change even when you have changed it with the Amplifier Control.	<ul style="list-style-type: none"> The AMP CONT has been turned "OFF". 	<ul style="list-style-type: none"> Turn the AMP CONT "ON".
The set value cannot be changed by the Amplifier Control of the unit.	<ul style="list-style-type: none"> The AMP Control of the Center Unit is being used. 	<ul style="list-style-type: none"> Release the AMP Control mode of the Center Unit.
The Amplifier Control cannot be operated from the Center Unit.	<ul style="list-style-type: none"> An incorrect ID number is used for the Master amplifier. The ID number of the amplifier has been changed. 	<ul style="list-style-type: none"> Always set the ID number of the Master amplifier to "0". After you have changed the ID number of an amplifier, turn Off the POWER switch of the Center Unit first, then turn it On again.

Specifications

Specifications subject to change without notice.

Audio Section	KAC-X811D
RMS Power Output (+B = 14.4 V, CEA-2006)	
(4 Ω) (1.0 % THD+N)	533 W
(2 Ω) (1.0 % THD+N)	919 W
(1 Ω) (1.0 % THD+N)	1016 W
Dynamic Power (+B = 14.4 V, CEA-2006)	566 W
Output Regulation (+B = 14.4 V, CEA-2006)	under 0.2 dB (4 Ω)
Signal to Noise Ratio (CEA-2006)	74 dBA (W/4 Ω)
(Bypass) (CEA-2006)	74 dBA (W/4 Ω)
Low Pass Filter Frequency (24 dB/oct.)	50 – 200 Hz (variable)
Infrasonic Filter Frequency (24 dB/oct.)	OFF / 15 / 25 Hz
Phase Inverter	0° (Normal) / 180° (Reverse)
Band Reject Filter Frequency	40 – 200 Hz (variable)
Frequency Response (+0, -3 dB)	5 Hz – 200 Hz
Sensitivity (rated output) (MAX.)	0.2 V
(MIN.)	5.0 V
Input Impedance	10 kΩ

Audio Section	KAC-PS811D
Max Power Output	1600 W
Rated Power Output (+B = 12.0 V)	
(4 Ω) (20 Hz – 200 Hz, 0.5 % THD)	300 W × 1
(2 Ω) (100 Hz, 0.5 % THD)	600 W × 1
Rated Power Output (+B = 14.4 V)	
(4 Ω) (20 Hz – 200 Hz, 0.5 % THD)	400 W × 1
(4 Ω) (DIN45324, +B = 14.4 V)	400 W × 1
(2 Ω) (100 Hz, 0.5 % THD)	800 W × 1
(1 Ω) (100 Hz, 1.0 % THD)	1000 W × 1
Low Pass Filter Frequency (24 dB/oct.)	50 – 200 Hz (variable)
Infrasonic Filter Frequency (24 dB/oct.)	OFF / 15 / 25 Hz
Phase Inverter	0° (Normal) / 180° (Reverse)
Band Reject Filter Frequency	40 – 200 Hz (variable)
Frequency Response (+ 0 , - 3 dB)	5 Hz – 200 Hz
Signal to Noise Ratio	100 dB
Sensitivity (rated output) (MAX.)	0.2 V
(MIN.)	5.0 V
Input Impedance	10 kΩ

Amplifier Control Section (EQ)	KAC-X811D/PS811D
Bass frequency	60 / 80 / 100 / 200 Hz
Bass level	-15 — +15 dB
Bass Q factor	1.00 / 1.25 / 1.50 / 2.00

General	KAC-X811D/PS811D
Operating Voltage	14.4 V (11 – 16 V allowable)
Current Consumption (+B = 12.0 V, 100 Hz, 10 % THD, 4 Ω)	55 A
Dimensions (W × H × D)	386 × 61 × 259.5 mm
.....	15-3/16 × 2-3/8 × 10-3/16 inch
Installation Size (W × H × D)	386 × 61 × 265 mm
.....	15-3/16 × 2-3/8 × 10-3/8 inch
Weight	4.07 kg (8.97 lbs)

KENWOOD

Free Manuals Download Website

<http://myh66.com>

<http://usermanuals.us>

<http://www.somanuals.com>

<http://www.4manuals.cc>

<http://www.manual-lib.com>

<http://www.404manual.com>

<http://www.luxmanual.com>

<http://aubethermostatmanual.com>

Golf course search by state

<http://golfingnear.com>

Email search by domain

<http://emailbydomain.com>

Auto manuals search

<http://auto.somanuals.com>

TV manuals search

<http://tv.somanuals.com>