



KeysFitness

e2.0

Owner's Manual KF-E2.0

Customer Service
(800) 340-0482

Manufactured By:
Keys Fitness Products
4009 Distribution Drive
Suite 250
Garland, TX 75041

CAUTION

Read all precautions and instructions in this manual before using this equipment.

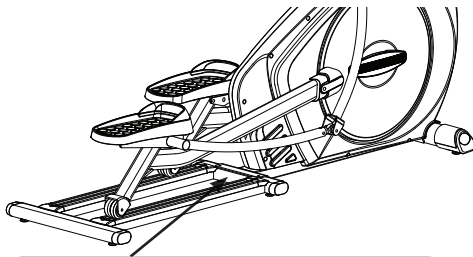

Model Name : KF-E2.0

Serial Number : _____

Serial Number can be found at the above specified location.

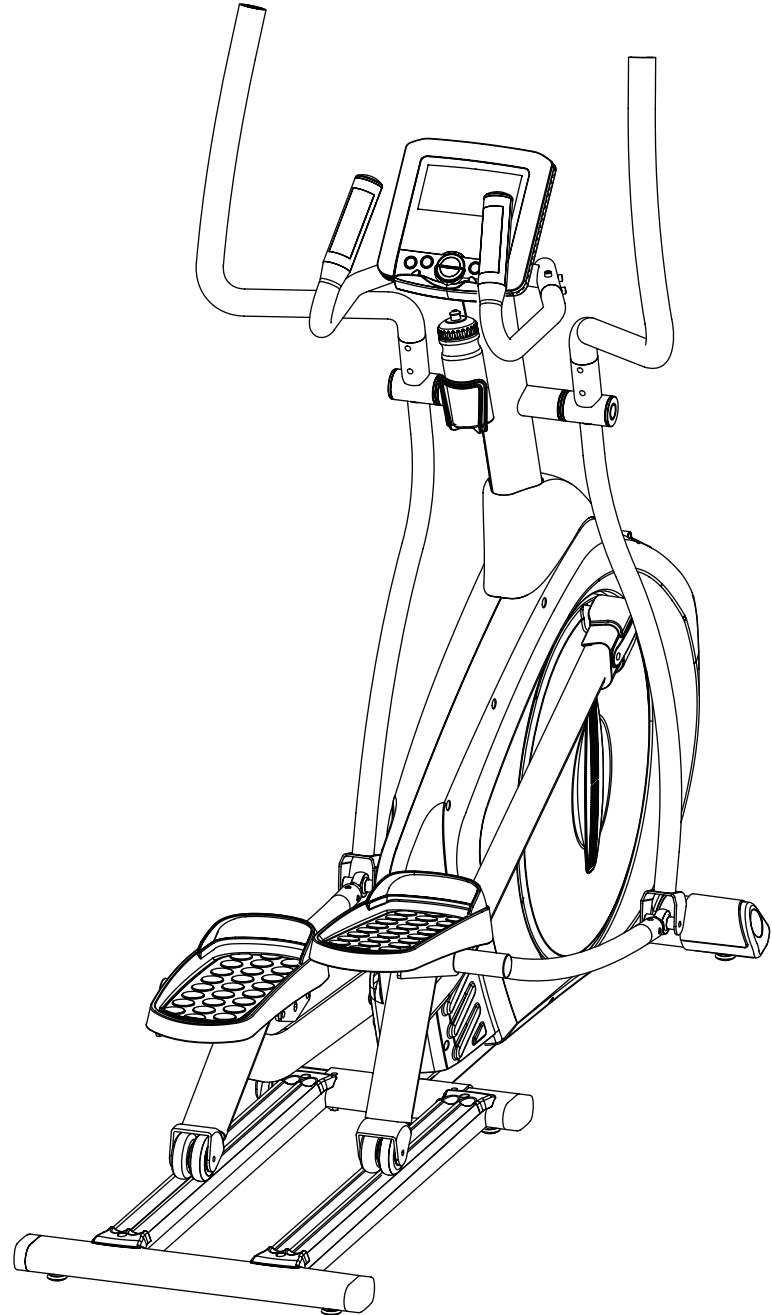

**315-00131
09/18 Rev 9.0**

TABLE OF CONTENTS

Table of Contents	2
Important Safety Information	3
Assembly	4
Parts Identifier	5
Assembly Steps	6
Console Information	18
Maintenance Instruction	25
Workout Information	27
Parts list	31
Exploded View	33
Warranty	35

THANK YOU

THANK YOU for making this unit a part of your exercise program. Keys Fitness Products Fitness assures the very best in value, appearance, durability and biomechanics. This manual will guide you through the assembly process. If at any time you are having trouble with the assembly or use of this product, then please contact us at our Keys Fitness Help line. We have trained service technicians on site to take care of you, our valued customer.

REGISTRATION CARD

To avoid unnecessary delays in warranty parts and to insure that a permanent record of your purchase is on file with our company, be sure to send in the warranty registration card or register on-line at www.keysfitness.com within 10 days of purchase.

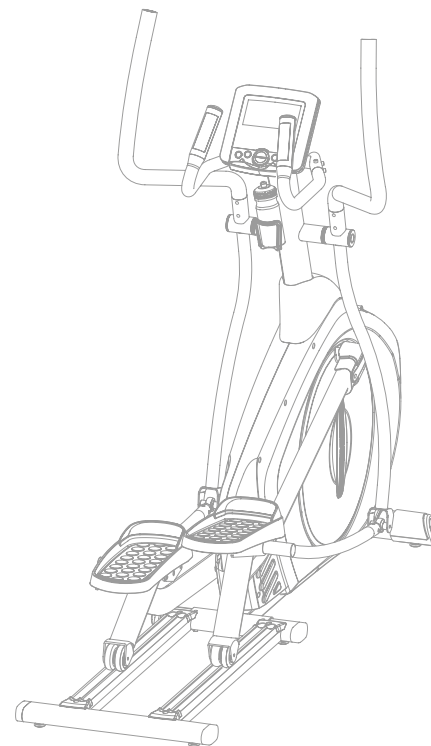

Keys Fitness series
 MODEL: KF-E2.0
 QUESTIONS?
 CALL

(800) 340-0482
 Monday-Friday
 8:30 am - 5:30 pm Central Time

WARNING! Before using this unit or starting any exercise program, consult your physician. This is especially important for persons over the age of 35 and/or persons with pre-existing health problems. The manufacturer or distributor assumes no responsibility for personal injury or property damage sustained by or through the use of this product. To reduce the risk of electrical shock, burns, fire, or other possible injuries to the user, it is important to review this manual and the following precautions before operation.

SAFETY PRECAUTIONS AND TIPS

1. It is the owner's responsibility to ensure that all users of this unit have read the Owner's Manual and are familiar with warnings and safety precautions.
2. This unit has a user maximum capacity of **275** pounds.
3. The unit should only be used on a level surface and is intended for indoor use only. The unit should not be placed in a garage, patio, or near water and should never be used while you are wet. Keys Fitness recommends a mat be placed under the unit to protect floor or carpet and for easier cleaning.
4. Follow safety information in regards to plugging in your unit. Do not run the power cord underneath your unit. Do not operate the unit with a damaged or frayed power cord.
5. Wear comfortable, good-quality walking or running shoes and appropriate clothing. Do not use the unit with bare feet, sandals, socks or stockings.
6. Always examine your unit before using to ensure all parts are in working order.
7. Allow the unit to fully stop before dismounting.
8. Pets should never be allowed near the unit.
9. Do not leave children unsupervised near or on the unit.
10. Never operate the unit where oxygen is being administered, or where aerosol products are being used.
11. Never insert any object or body parts into any opening.
12. For safety and to prevent damage to your unit, no more than one person should use the unit at a time.
13. Always unplug the unit before cleaning and/or servicing. Service to your unit should only be performed by an authorized service representative, unless authorized and/or instructed by the manufacturer.
14. Failure to follow these instructions will void the unit warranty.

Thank you for purchasing the Keys Fitness **KF-E2.0!** The quality product you have chosen was designed to meet your needs for cardiovascular exercise. Before you start, please read the Owner's Manual and become familiar with the operation of your new unit. Remember to take time to perform stretching exercises, provided in this manual, to help avoid injury. If you are taking medication, consult your physician to see what effect the medication will have on your exercise heart rate. If you have heart problems, you are not active, and/or are over the age of 35 years, do not use the pre-set programs or start an exercise program without first contacting and receiving approval from your physician. To avoid the risk of electrical shock, always keep the console dry. Do not spill liquids on the console. Keys Fitness recommends a sealed water bottle for beverages consumed while using the unit.



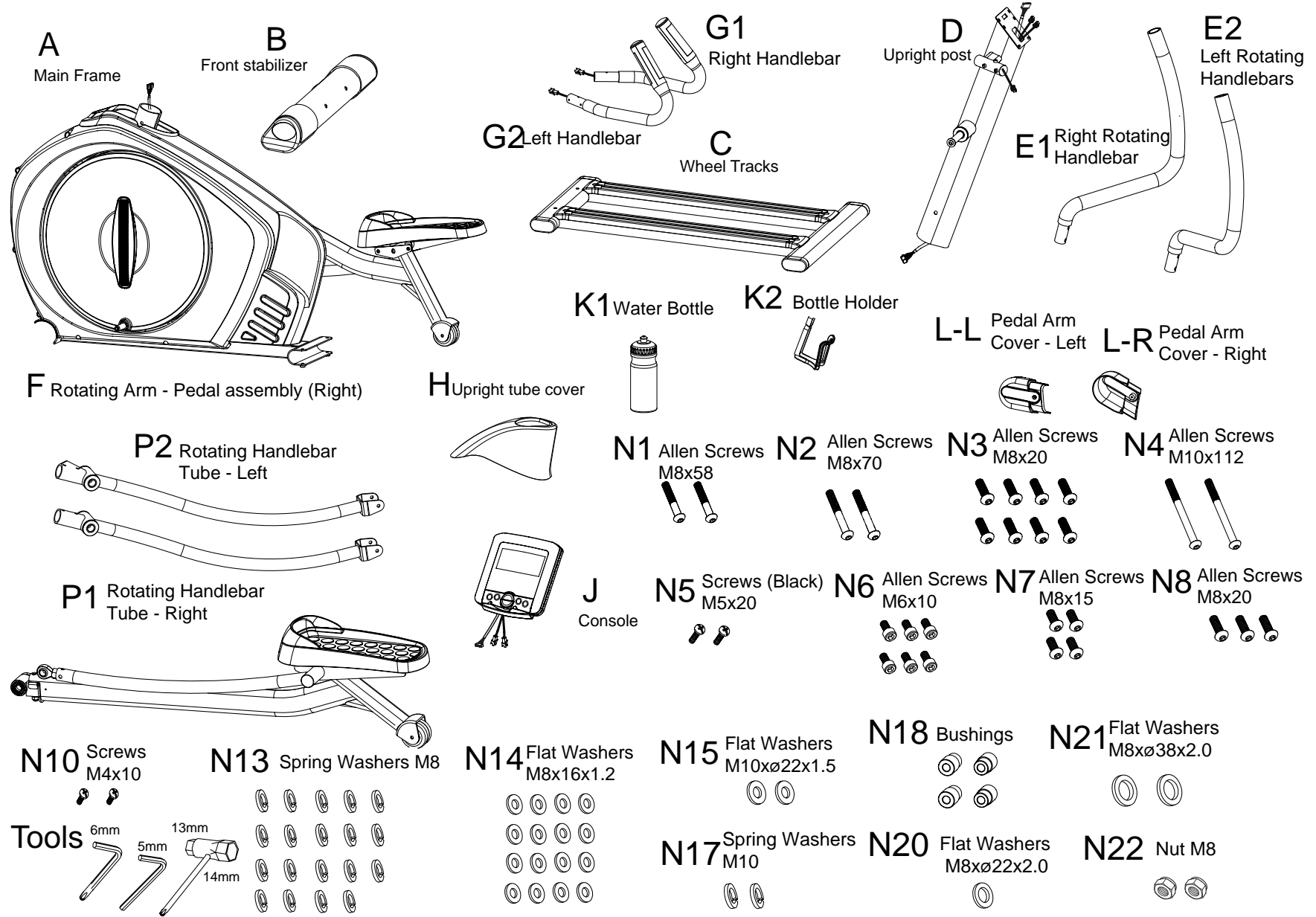

 Prior to assembly, remove components from the box and verify that all the listed parts were supplied.

1

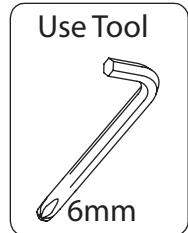

ASSEMBLY FOR FRONT STABILIZER

Secure the front stabilizer (B) to the main frame (A) using 2 allen screws (N4), 2 spring washers (N17) and 2 flat washers (N15).

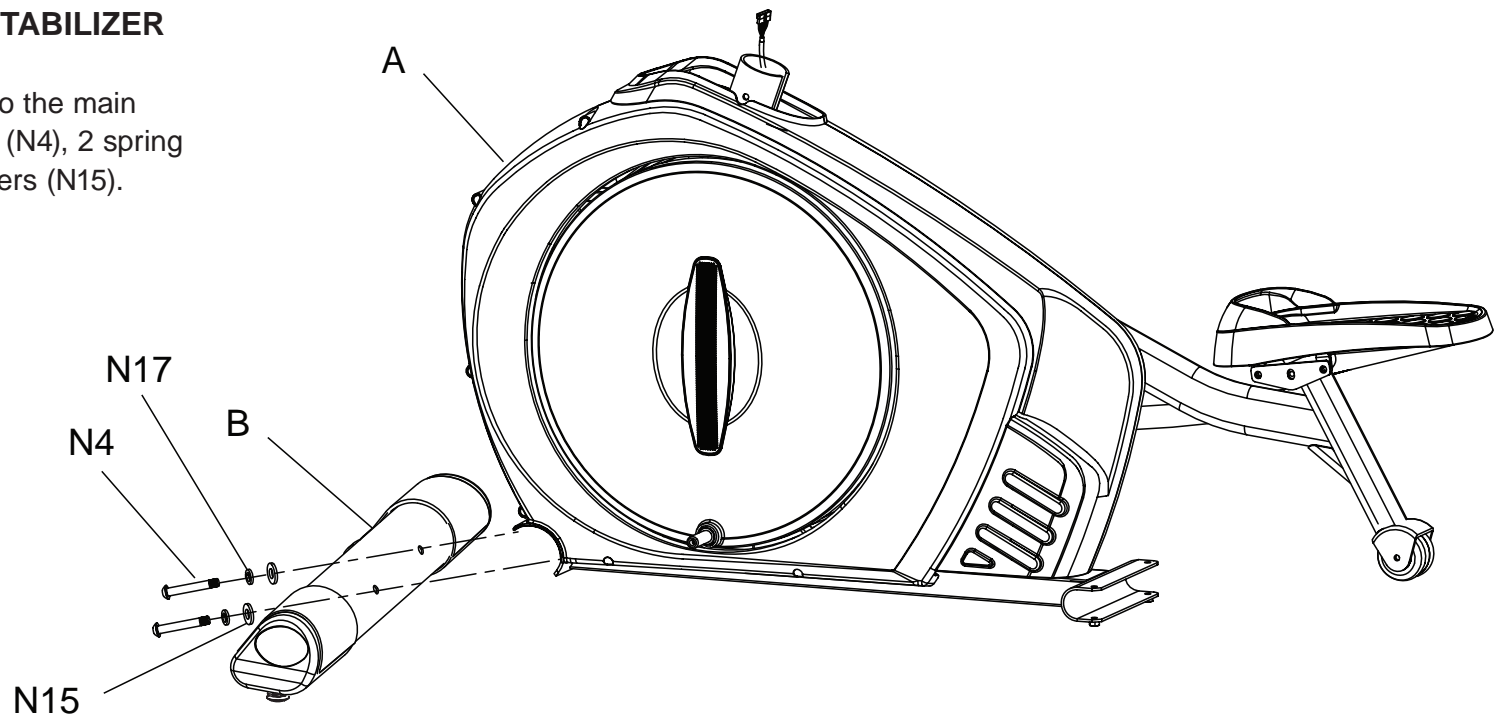

ASSEMBLY FOR REAR WHEEL TRACKS

Secure the rear wheel tracks (C) to the main frame (A) using screws (N1), springs washers (N13), and flat washers (N14).

2

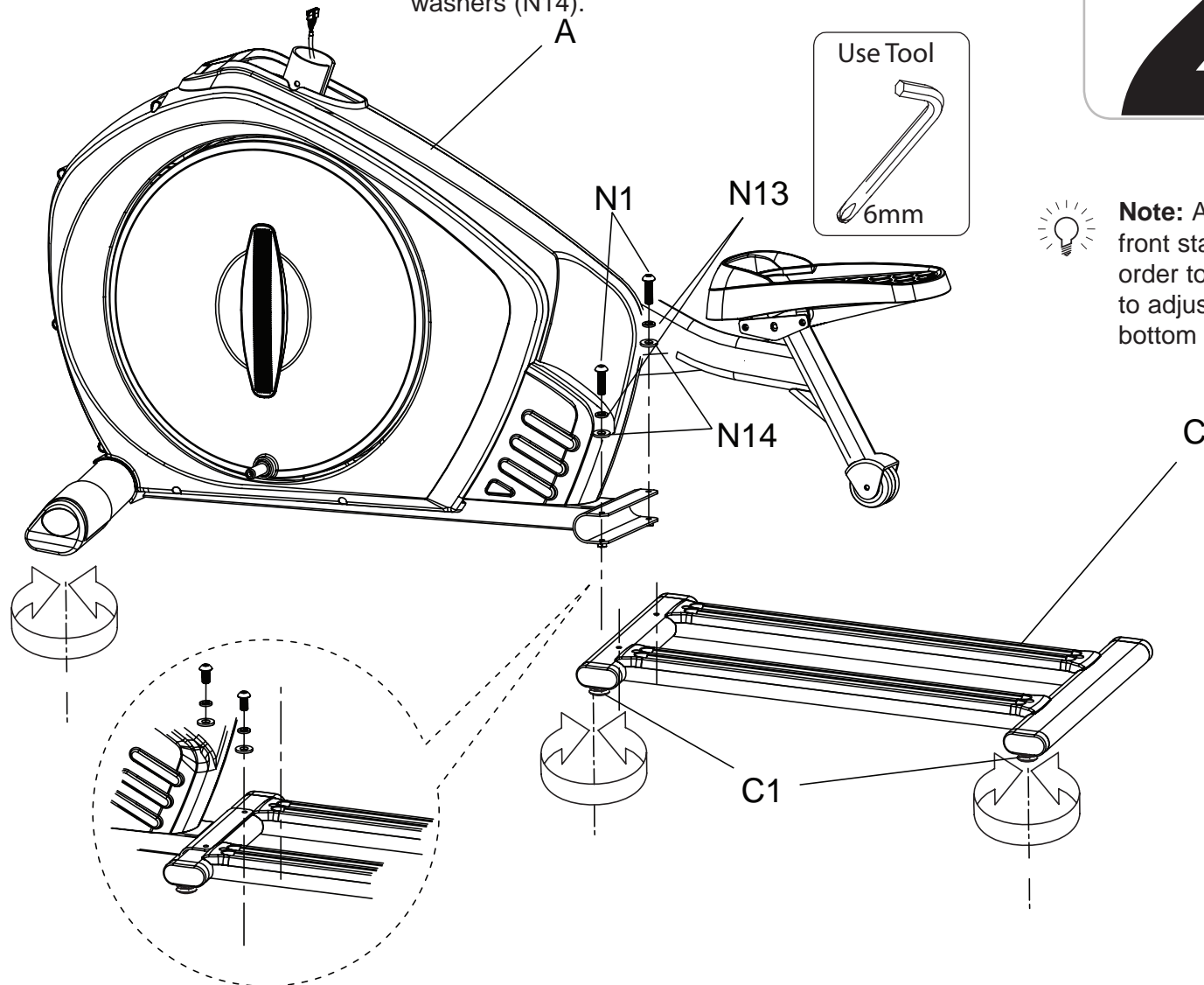

Note: After finishing the installation of both the front stabilizer bar and the rear wheel tracks, in order to add stability to the unit, you may need to adjust the levelers that are located on the bottom of the stabilizer bars.

3

ASSEMBLY FOR UPRIGHT POST

Step 1:

Insert the upright post cover (H) onto the upright post (D) from the bottom side.

Step 2:

Connect the lower sensor wire (A2) with the upper sensor wire (D2).

Step 3:

Mount the upright post (D) to the main frame (A) and secure using 4 allen screws (N7), 4 spring washers (N13), and 4 flat washers (N14).

Step 4:

Slide the console tube cover down to conceal tube connection.

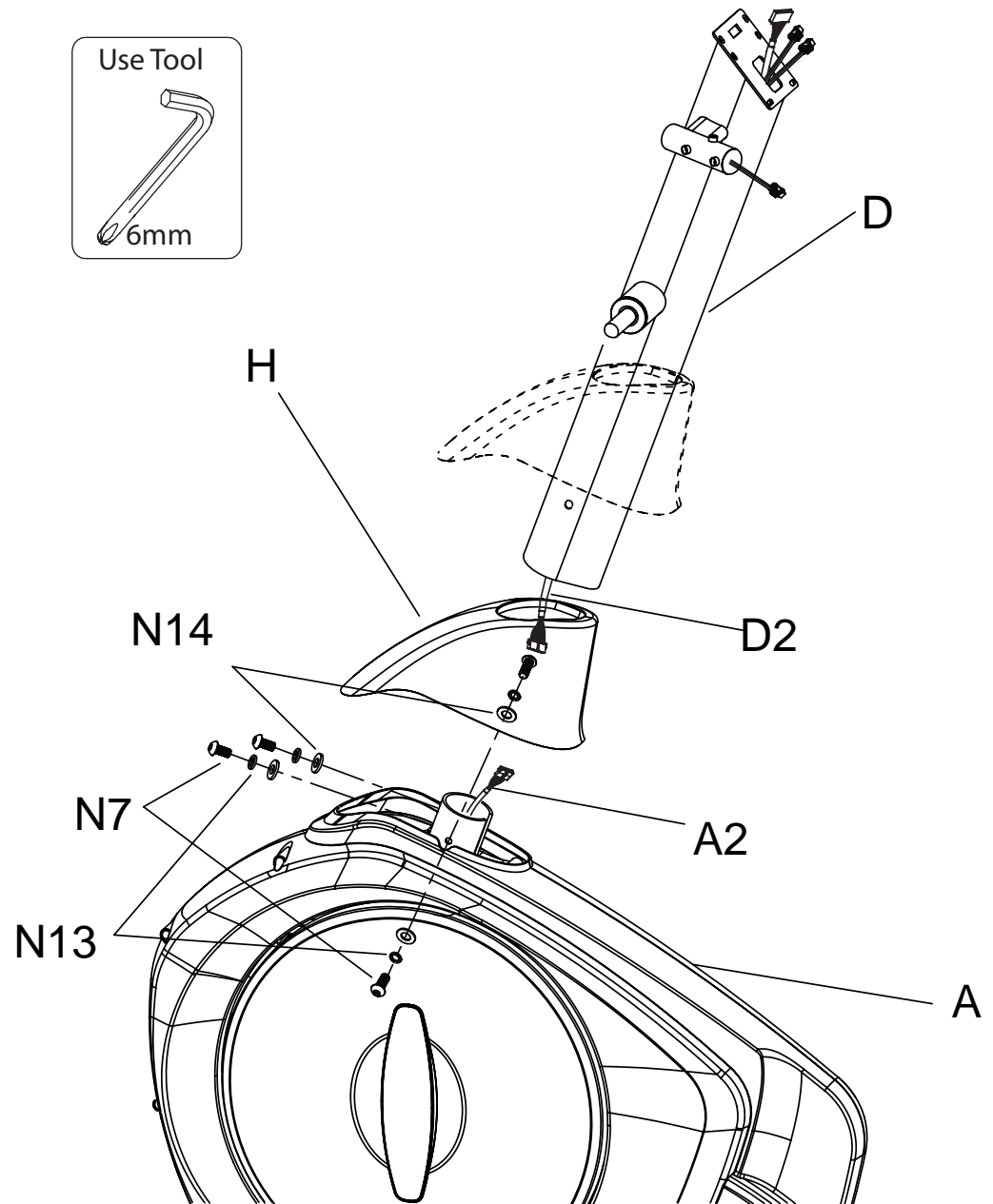

ASSEMBLY FOR STATIONARY HANDLEBARS

Step 1:

Connect the pulse wire (G1-1) from the right handlebar (G1) to the pulse wire (D2-1) from the upright post (D).

Step 2:

Attach the right stationary handlebar (G1) to the right handlebar mount on the upright post (D) and secure using 3 allen screws (N6).

Step 3:

Repeat steps 1 and 2 for the left stationary handlebar (G2).

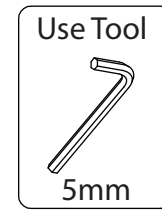
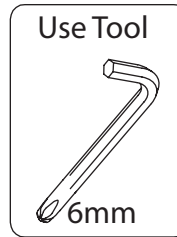
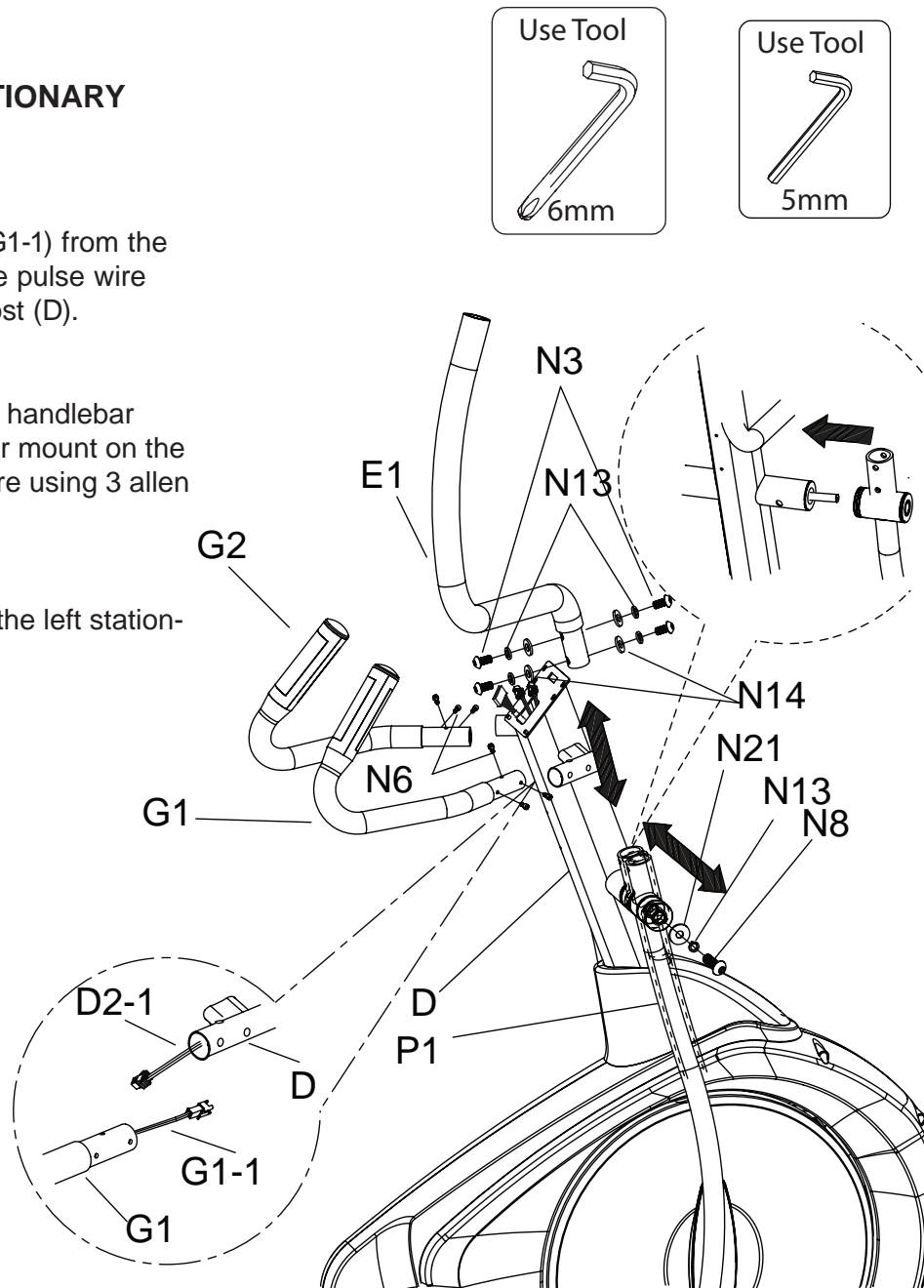

4

ASSEMBLY FOR RIGHT HANDLEBAR

Step 1:

Connect the right rotating handlebar tube (P1) to the upright post (D) at the arm joint and secure using allen screw (N8), spring washer (N13) and flat washer (N21).

Step 2:

Attach the right rotating handlebar (E1) to the right rotating handlebar tube (P1) and secure using 4 allen screws (N3), 4 spring washers (N13), and 4 flat washers (N14).

5

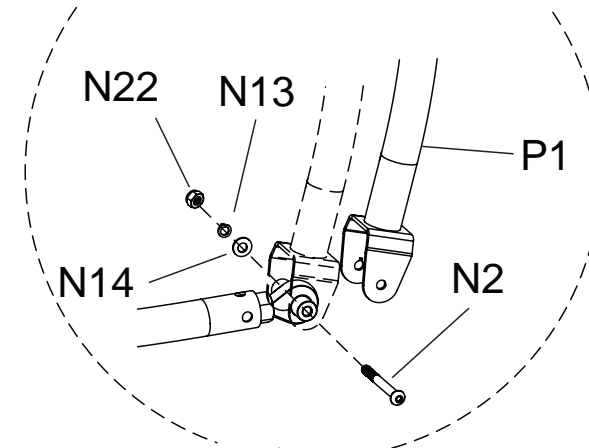
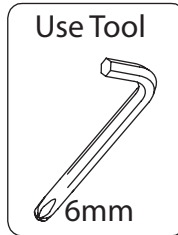

ASSEMBLY FOR RIGHT ROTATING HANDLEBAR TUBE

Step 1:

Insert 2 bushings (N18) on the tapered ends into the right pedal arm joint (A) - one for each side.

Step 2:

Attach the right pedal arm (A) to the right rotating handlebar tube (P1) and secure using allen screw (N2), spring washer (N13), flat washer (N14) and nut (N22).

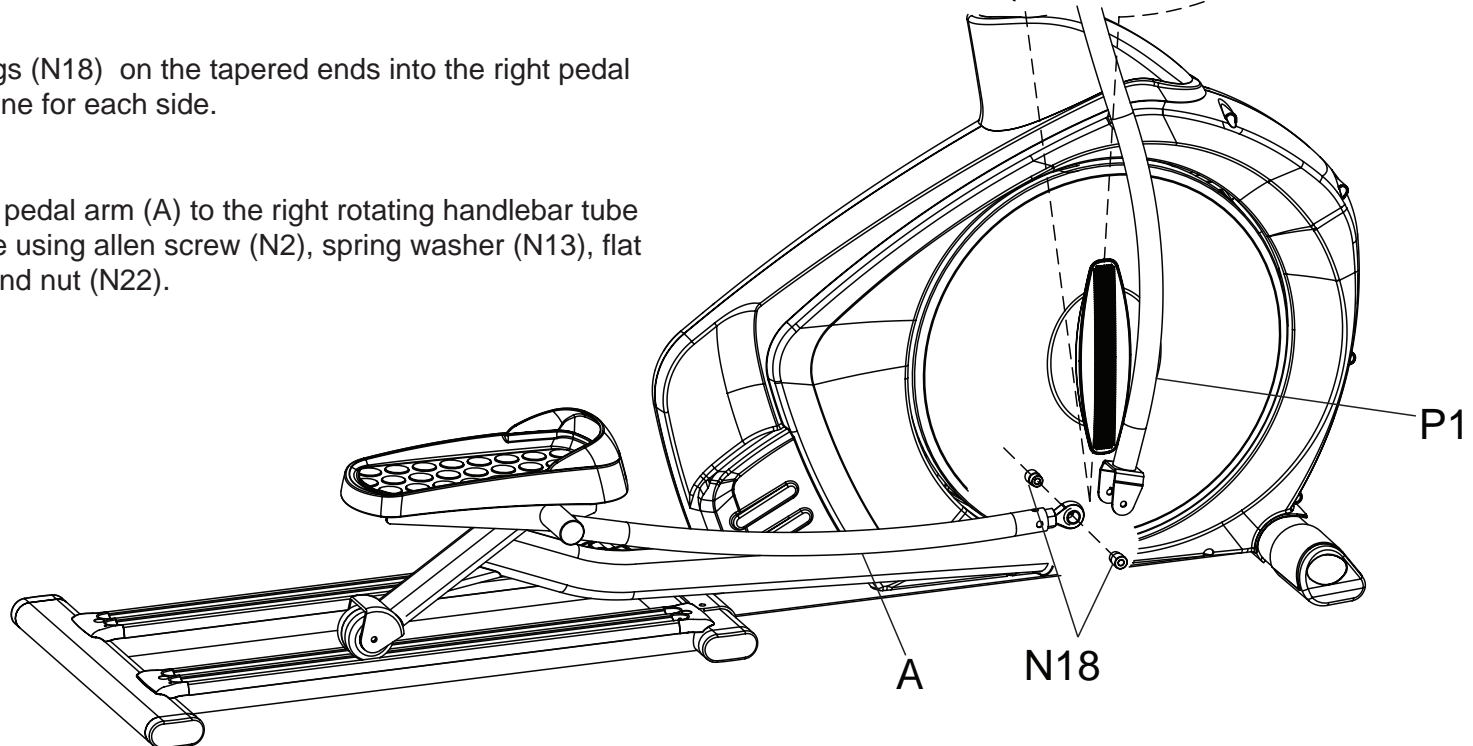

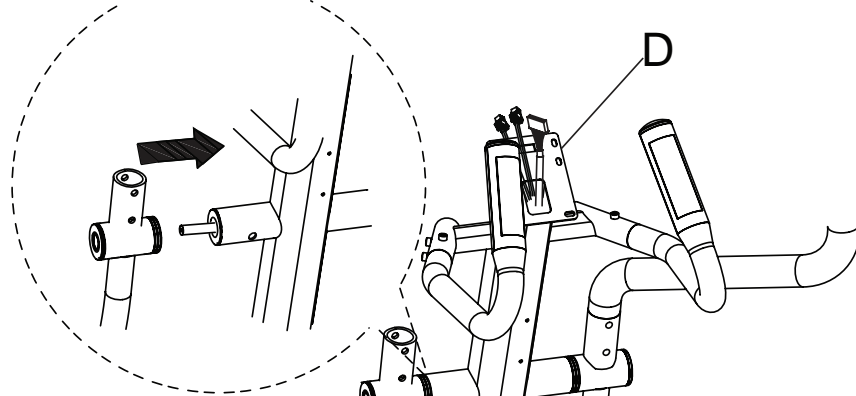
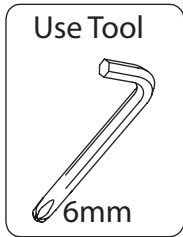

6

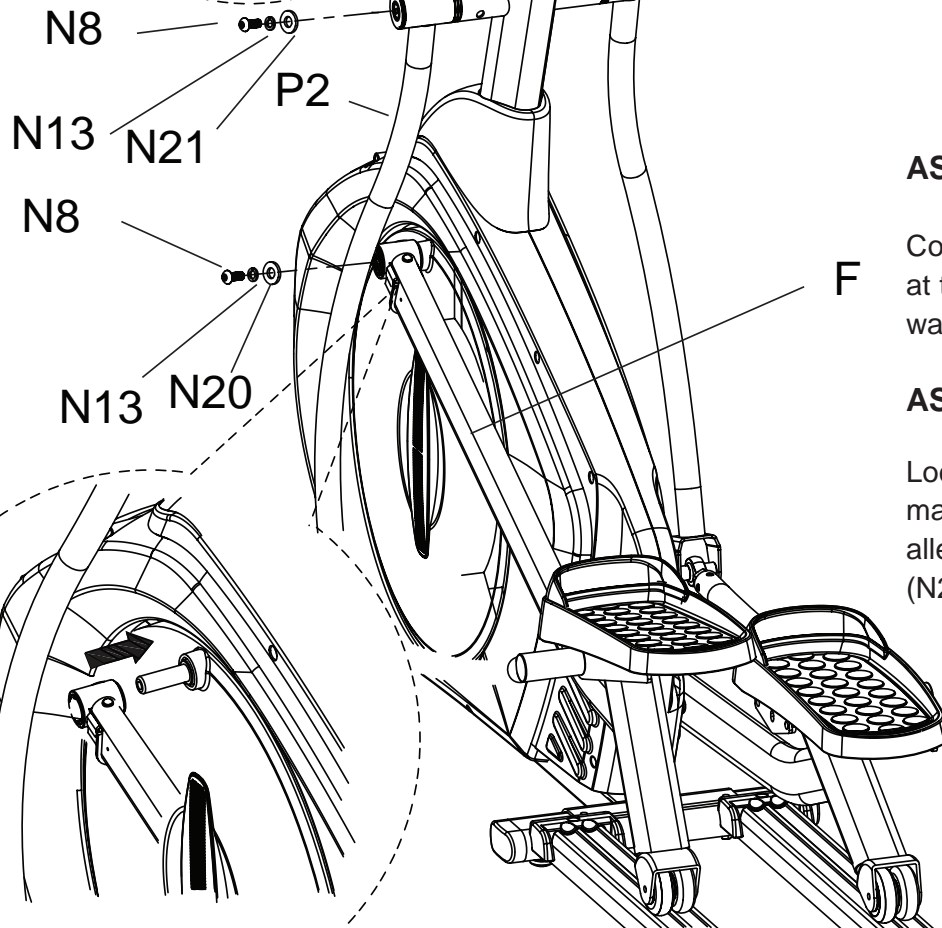

ASSEMBLY FOR LEFT ROTATING HANDLEBAR

Connect the left rotating arm (P2) to the upright post (D) at the arm joint and secure using allen screw (N8), spring washer (N13) and flat washer (N21).

ASSEMBLY FOR LEFT PEDAL

Locate the left pedal assembly (F) and attach it to the main frame (A) at the pedal tube mount. Secure with allen screw (N8), spring washer (N13) and flat washer (N20).

7

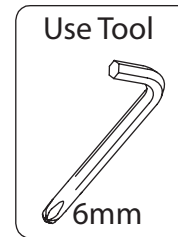
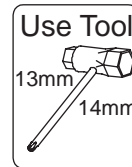

ASSEMBLY FOR LEFT ROTATING HANDLEBAR TUBE

Step 1:

Insert 2 bushings (N18) on the tapered ends into the left pedal arm joint (F) - one for each side.

Step 2:

Attach the left pedal arm (F) to the right rotating handlebar tube (P2) and secure using allen screw (N2), spring washer (N13), flat washer (N14) and nut (N22).

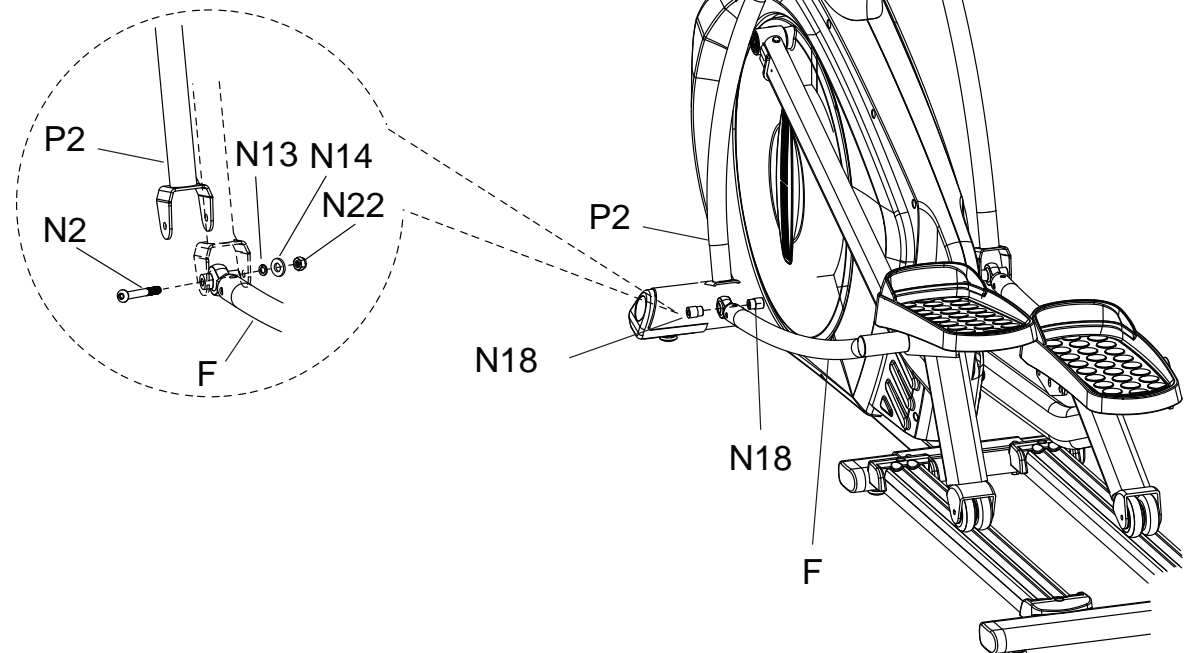

8

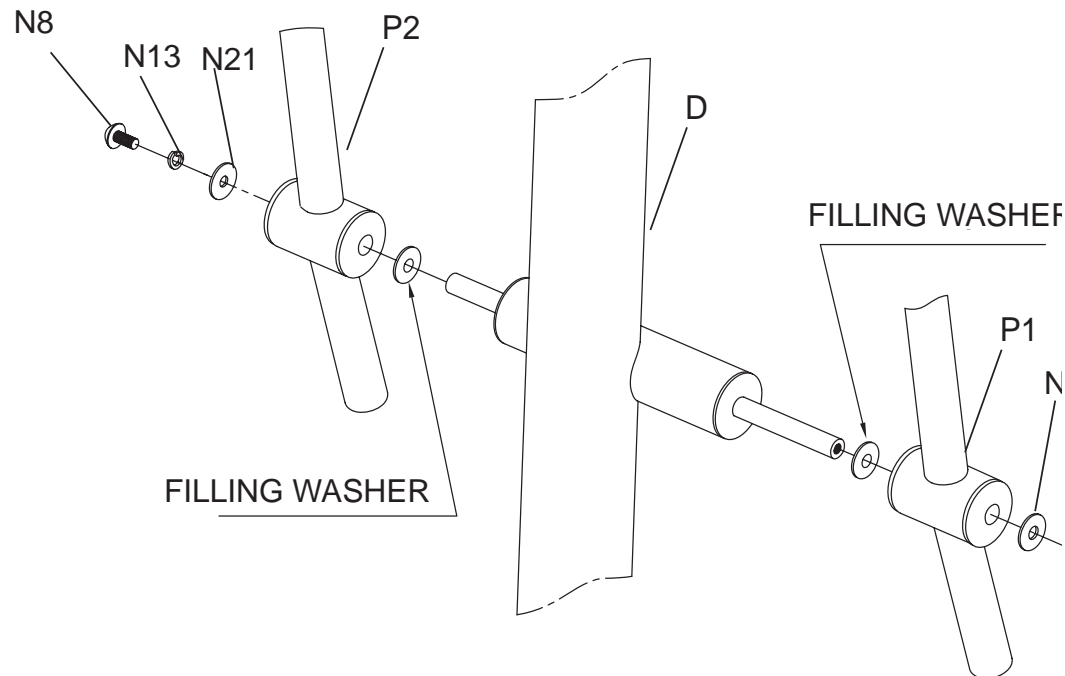

ASSEMBLY FOR FILLING WASHER

Step 1:

If the arms appear to have too much side to side movement, check and see if there is any gap in between the handlebar tube and the upright post arm joint by inserting one or more filling washers in the handlebar tube connection.

Step 2:

If there is a gap for the filling washer to fit, the handlebar(s) should be uninstalled to fit the filling washer in the handlebar joint. Note that the filling washer can be inserted on the right handlebar, left handlebar or both (2 filling washers have been included).

Step 3:

Re-install the handlebar assembly to the upright post.

9

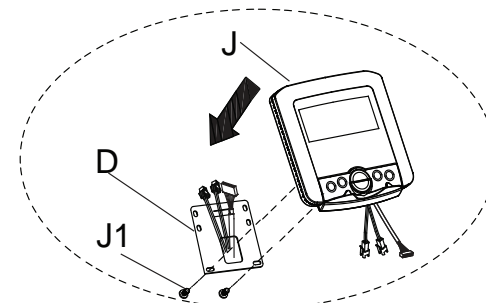
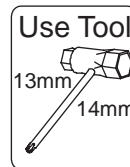
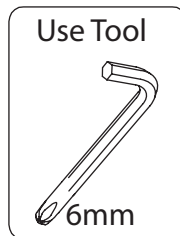

ASSEMBLY FOR LEFT ROTATING HANDLEBAR

Attach the left rotating handlebar (E2) to the left rotating handlebar tube (P2) and secure using 4 allen screws (N3), 4 spring washers (N13) and 4 flat washers (N14).

ASSEMBLY FOR PEDAL JOINT COVER

Step 1:

Install left pedal joint cover (L-L) to conceal pedal arm connection and secure using screw (N8).

Step 2:

Repeat step 1 on the right side with right pedal joint cover (L-R).

ASSEMBLY FOR CONSOLE

Step 1:

Remove the screws (J1) from the back of the console.

Step 2:

Connect the pulse wires, sensor wires and the toggle wires with the corresponding wires on the console.

Step 4:

Gently slide the wires down the upright post and secure the console (J) to the upright post (D) using the screws (J1).

14 Assembly

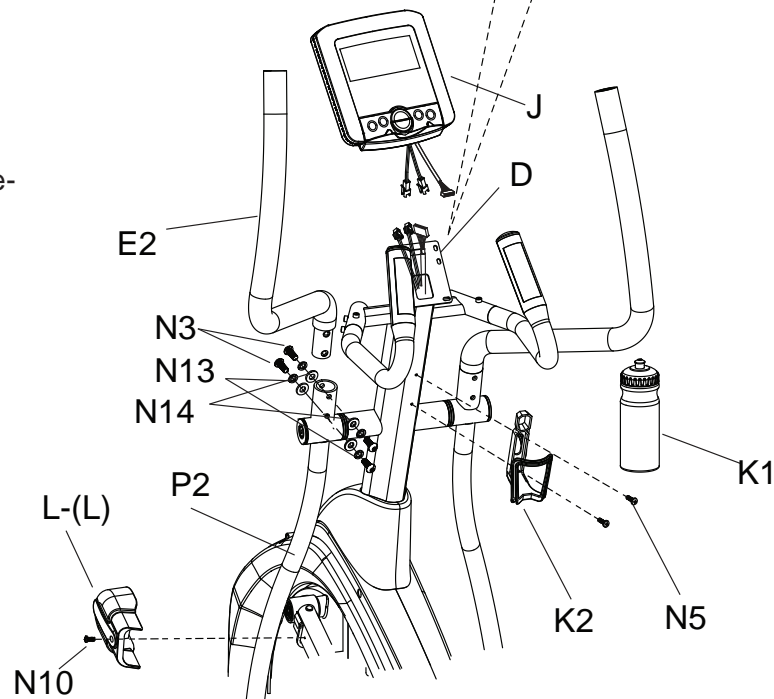

ASSEMBLY FOR WATER BOTTLE HOLDER

Step 1:

Attach the water bottle holder (K2) and secure to the upright post (D) using 2 screws (N5).

Step 2:

Place water bottle (K1) inside water bottle holder (K2).

e2.0

Congratulations!
You have completed the assembly of
your new Keys Fitness E2.0 Elliptical!

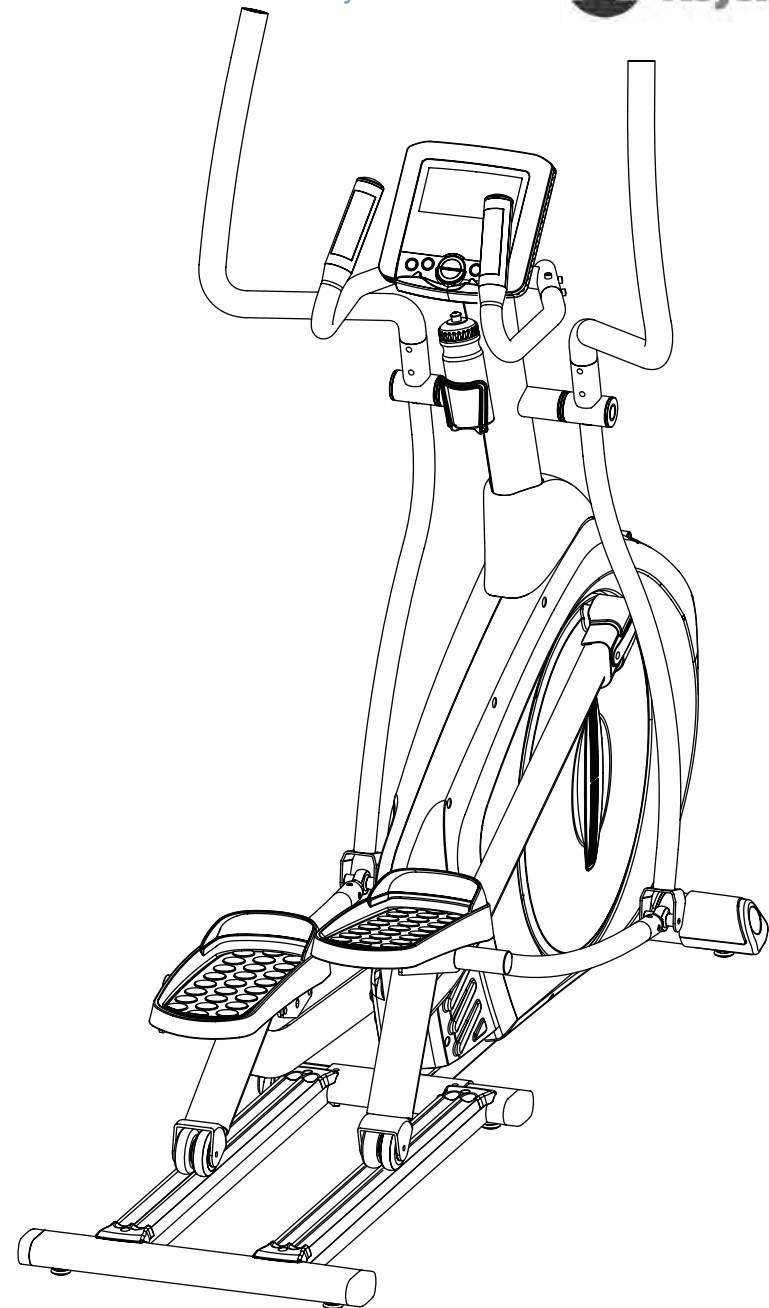

ADAPTOR PLUG-IN LOCATION

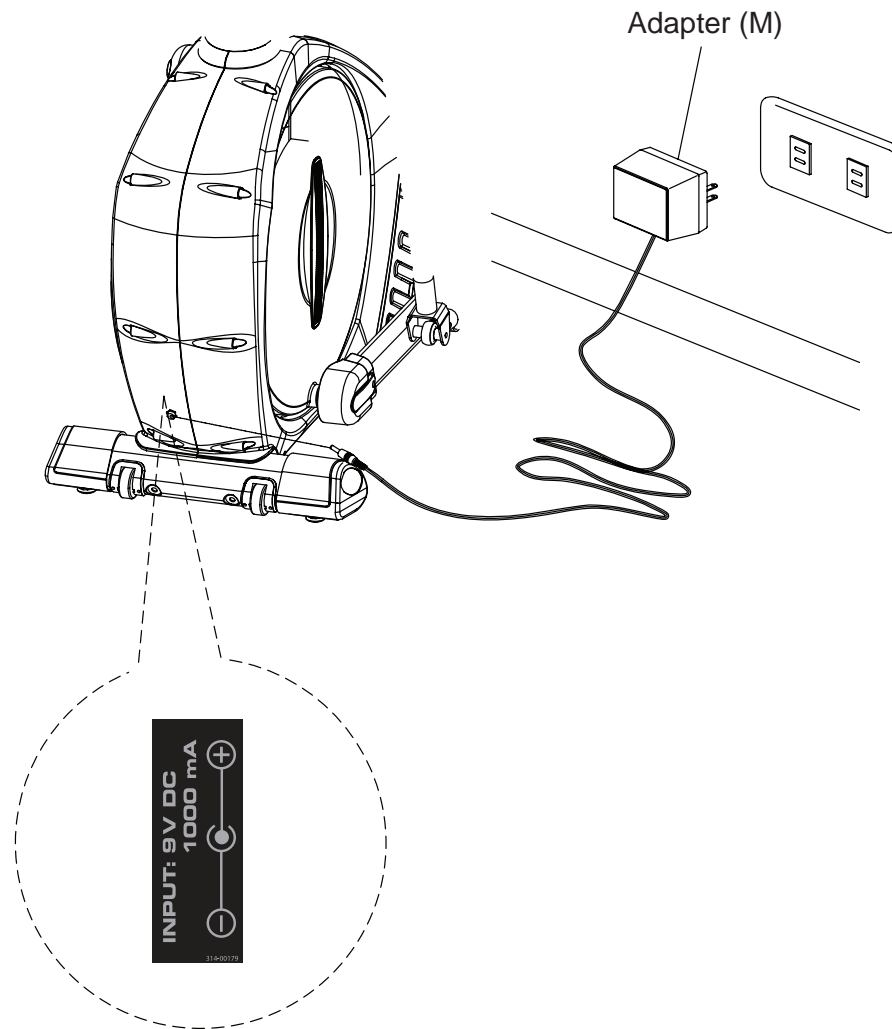

MOVING YOUR UNIT

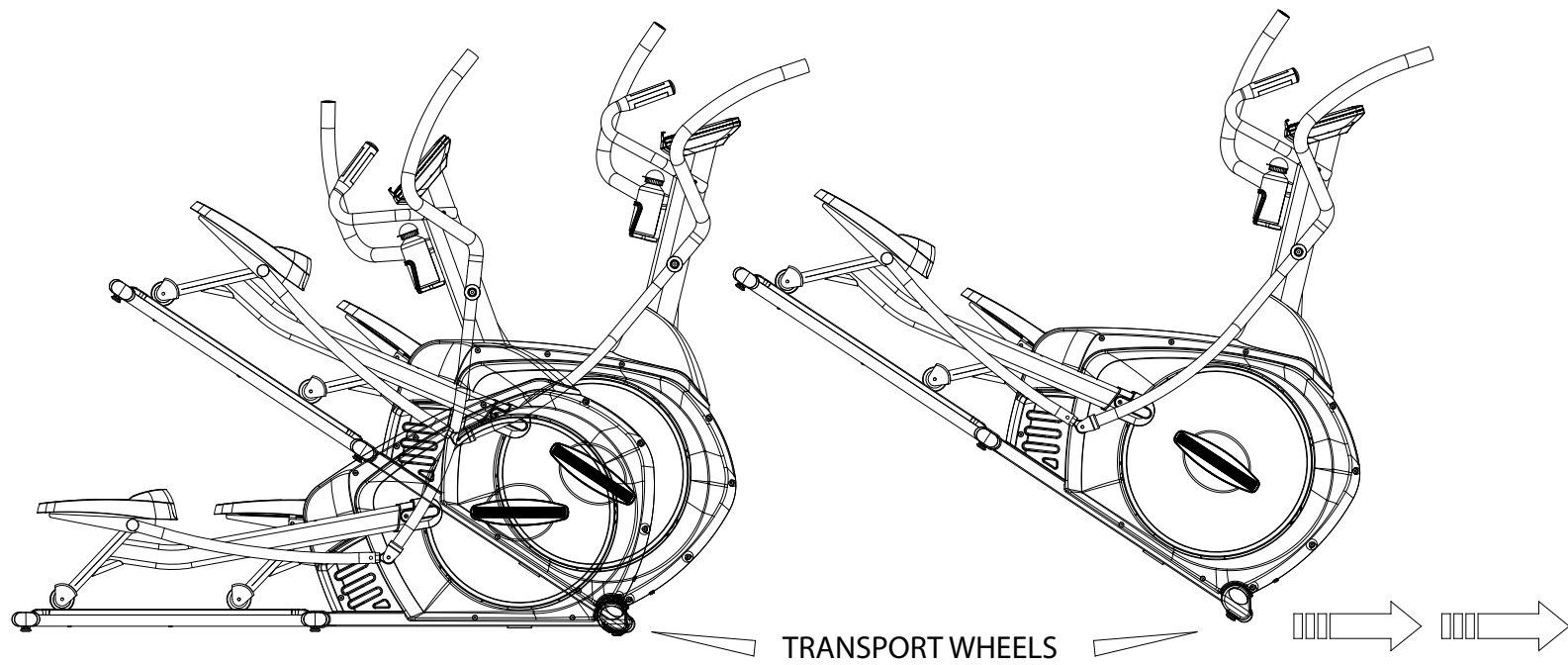



Console Information

www.keysfitness.com



DISPLAY:

- 1) **Program Selection**
Manual, Program (presets), and Watt
- 2) **Segment Program Profile**
Rows signify tension level, whereas columns signify interval of time
- 3) **Time**
- 4) **Speed**
- 5) **One touch program profile buttons**
- 6) **Start / Stop Key**
- 7) **Recovery Key**
Evaluates overall fitness level
- 8) **Up (+) and Down (-) Keys**
- 9) **Reset Key**
Resets function values to default
- 10) **Mode**
Confirms selection
- 11) **Distance**
- 12) **Watt / Calories**
- 13) **User Data Display**
Displays the user selected profile



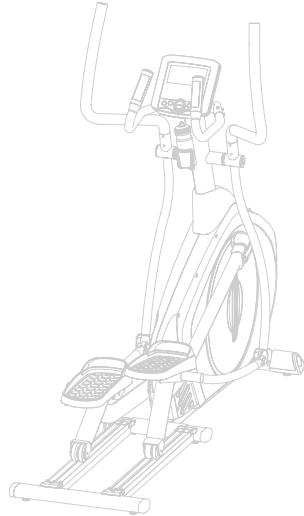

CONSOLE FUNCTION PARAMETERS

TIME	0:00~99:59.
WATTS	0~999 WATTS
CALORIES	0~9999
TEMPERATURE	0~60°C / 32~99°F
GENDER	FEMALE / MALE
AGE	10-99
HEIGHT	100-200 (CM) / 40-80 (INCH)
PULSE	P~30~240
HEART SYMBOL	ON / OFF blinks
PROGRAM	P1~P12
WATT CONSTANT	10~350 WATTS
PERSONAL	U1~U4
WEIGHT	20-150 (KG) / 40-350 (LB)

CONSOLE BUTTONS:

START/STOP:

This button is used to start or stop training

RECOVERY:

This button is used to begin the Recovery feature of the console (refer to Console Function section for more information).

UP/DOWN:

These buttons are used to change programs and settings. During your workout, these buttons are used to increase / decrease resistance.

RESET:

This button is used to return to main menu screen at any time. It is also used to reset all values to zero.

MODE:

This button is used as an enter key, and will allow user to move to the next setting that can be changed. When pressed and held for 2 seconds or more, console will go back to the user profile selection screen.

ONE TOUCH PROGRAM PROFILE BUTTONS:

These 12 program profile one touch buttons allow quicker selection to the desired type of workout.

CONSOLE FUNCTIONS:

TIME:

If a target time was not selected, time will count up from 00:00 to maximum 99:59. When working out with a target time, time will count down from target to 00:00. When selecting target time, use the +/- buttons, the time will change in 1 minute increments and can range from 1:00 min to 99:00 mins. Once target is accomplished, window will flash to signify the end of workout. You may press start button twice to continue.

SPEED:

Displays current training speed from 0.0 to maximum 99.9 KM or MPH.

RPM:

Displays current training revolutions per minute.

DISTANCE:

If a target distance was not selected, distance will count up from 0.00 to maximum 99.50. When working out with a target distance, distance will count down from target to 0.0. When selecting target time, use the +/- buttons, the distance will change in 0.1 mile increments and can range from 0.00 miles to 99.50 miles. Once target is accomplished, window will flash to signify the end of workout. You may press start button twice to continue.

CALORIES:

If target calories were not selected, calories will count up from 0 to maximum 990. When working out with target calories, will count down from target to 0. When selecting target calories, use the +/- buttons, the calories will change in 10 calorie increments and can range from 0 calories to 990 calories. Once target is accomplished, window will flash to signify the end of workout. You may press start button twice to continue.

WATT:

Displays current training watt figures. A watt is a measurement of the amount of power generated by the user based on the resistance and speed.

RECOVERY:

After your workout, press "RECOVERY" button and keep holding on hand grips. All function display will stop except "TIME" starts counting down from 00:60 to 00:00. Screen will display your heart rate recovery status rating between F1-F6. F1 is the best, F6 is the worst. User may keep exercising to improve the heart rate recovery status. (Press the RECOVERY button again to return the main display.)

TEMPERATURE:

Screen will display room temperature in sleep mode.

Score	Condition	Heart Rate (from test HR minus end HR)
F1	Excellent	Above 50
F2	Good	40 ~ 49
F3	Average	30 ~ 39
F4	Fair	20 ~ 29
F5	Poor	10 ~ 19
F6	Very Poor	Under 10

GENERAL INFORMATION:

1. Start pedaling or press any button to start Console.
2. The console will shut down after 4 minutes of no activity, and will display room temperature. Begin pedaling or press any button to bring console back to operational state.
3. To reset console press and hold the MODE or RESET button for 2 seconds.
4. To begin workout without inputting any values (Quick Start Mode), simply press START/STOP once the console is turned on. Change resistance during workout by pressing the +/- buttons.

Note: The values calculated or measured by the console are for exercise purposes only, not for medical purposes.

GETTING STARTED:

When console is first turned on, user will be able to select a user profile. There are four profiles to choose from, U0-U4. Each profile allows the user to enter his/her information, such as Gender, Age, Height and Weight. Entering this information will allow a more accurate tracking of calories. **NOTE:** U0's profile is not saved in the console memory - will reset when the unit is unplugged, while the profiles in U1-U4 are saved in the console memory and can be retrieved after unit is turned off. To begin, first select desired profile (U0-U4) that will be edited. Press MODE button to confirm selection. The console will now allow user to select his/her gender. Use the +/- buttons on the console to select user's gender. Press MODE to confirm selection. Next, enter user's age. Use the +/- buttons on the console to select user's age. Press MODE to confirm selection. The console will now allow user to enter his/her height. Use the +/- buttons on the console to select user's height. Note: Height will be shown in inches. Press MODE to confirm your selection. Finally, enter user's weight. Use the +/- buttons on the console or on the upper handlebars to select user's weight. Press MODE to confirm selection.

PROGRAM INSTRUCTIONS:

Once profile is either created or selected, user will select the type of workout desired. The available workouts include Manual, Program, and Watt. Please press the Up (+) or Down (-) buttons to select a workout. If one is chosen and you would like to choose another, press RESET to go back.

MANUAL PROGRAM:

The manual program allows the user to manually adjust tension settings throughout his/her workout. The default tension level is 1. You may set desired time, distance, calories, resistance, distance, and pulse rate for your workout. If desired, user may bypass all of this, and simply press START/STOP button and enter into quick start mode. After selecting user profile, use the +/- buttons until the word MANUAL is displayed on top of the console LCD screen. Press MODE to confirm. Resistance will flash in the display. Use the +/- buttons to set desired resistance level. Press MODE to confirm selection. Repeat steps for time, distance, pulse, and calories. Press START/STOP to begin exercising at any time. You can change the tension level at any time during your workout session by pressing the +/- buttons.

PRESET PROGRAMS:

The console comes with 12 preset programs. After selecting user profile, use the +/- buttons until Program is selected (the word PROGRAM is dis-

played on top of the console LCD screen). Press MODE button to confirm selection. Use the +/- buttons until desired program is blinking (P1-P12) or simply press the quick key program selection. Press MODE button to confirm selection. The console will now allow user to select the level of workout (shown as bar level with adjacent number 1-10) by using the +/- buttons until the desired level is selected. Press MODE button to confirm selection. Time will flash in the display. Use the +/- buttons to set desired time. Press MODE to confirm selection. Repeat steps for distance, calories, and pulse. Press START/STOP to begin exercising at any time. You can change the level at any time during your workout session by pressing the +/- buttons.

WATT PROGRAM:

The watt program allows the user to set a target watt value. The unit will then keep this watt level constant. This means that if you exercise quickly the tension will decrease. If you exercise slowly the tension will increase to maintain the watt value entered. After selecting user profile, use the Up (+) or Down (-) buttons until the word WATT is blinking on top of the console LCD screen. Press mode to confirm selection. Adjust the watt value by pressing the +/- buttons and press mode to confirm. Repeat steps for time, distance, calories, and pulse. Press START/STOP to begin exercising at any time.

CHANGING BETWEEN US STANDARD AND INTERNATIONAL:

To switch console from ML (Miles per hour) to KM (Kilometers per hour). First, press reset. Next, press both the Mode and Reset buttons at the same time and hold for 2 seconds. The console will beep and will display the new setting (ML for Standard and KM for Metric).

MONITORING YOUR HEART RATE:

To obtain the greatest cardiovascular benefits from your exercise workout, it is important to work within your target heart rate zone. The American Heart Association (AHA) defines this target as 60%-75% percent of your maximum heart rate. Your maximum heart rate may be roughly calculated by subtracting your age from 220. Your maximum heart rate and aerobic capacity naturally decreases as you age. This may vary from one person to another, but use this number to find your approximate effective target zone. For example, the maximum heart rate for an average 40 year-old is 180 bpm. The target heart rate zone is 60%-75% of 180 or 108-135 bpm. See Fitness Safety on next page.

Before beginning your workout, check your normal resting heart rate. Place your fingers lightly against your neck, or against your wrist over the main artery. After finding your pulse, count the number of beats in 10 seconds. Multiply the number of beats by six to determine your pulse rate per minute. We recommend taking your heart rate at these times; at rest, after warming up, during your workout and two minutes into your cool down, to accurately track your progress as it relates to better fitness. During your first several months of exercising, the AHA recommends aiming for the lower part of the target heart rate zone-60%, then gradually progressing up to 75%.

According to the AHA, exercising above 75% of your maximum heart rate may be too strenuous unless you are in top physical condition. Exercising below 60% of your maximum will result in minimal cardiovascular conditioning. Check your pulse recovery rate – If your pulse is over 100 bpm five minutes after you stop exercising, or if it's higher than normal the morning after exercising, your exertion may have been too strenuous for your current fitness level. Rest and reduce the intensity next time.

Fitness Safety - The Heart Rate chart indicates average rate zones for different ages. A variety of different factors (including medication, emotional state, temperature and other conditions) can affect the target heart rate zone that is best for you. Your physician or health care professional can help you determine the exercise intensity that is appropriate for your age and condition.

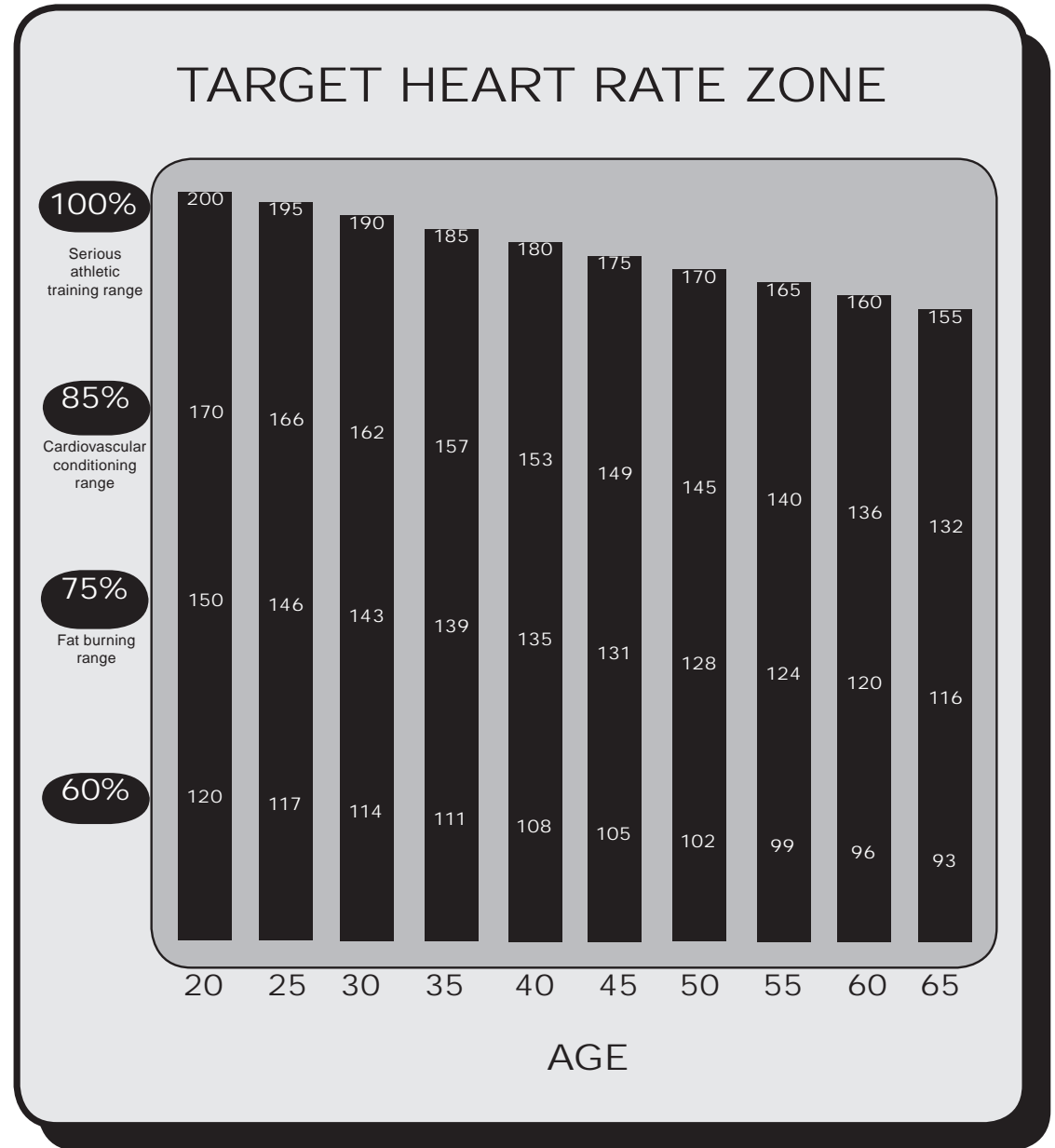

 **KeysFitness** **Maintenance Instruction**
www.keysfitness.com



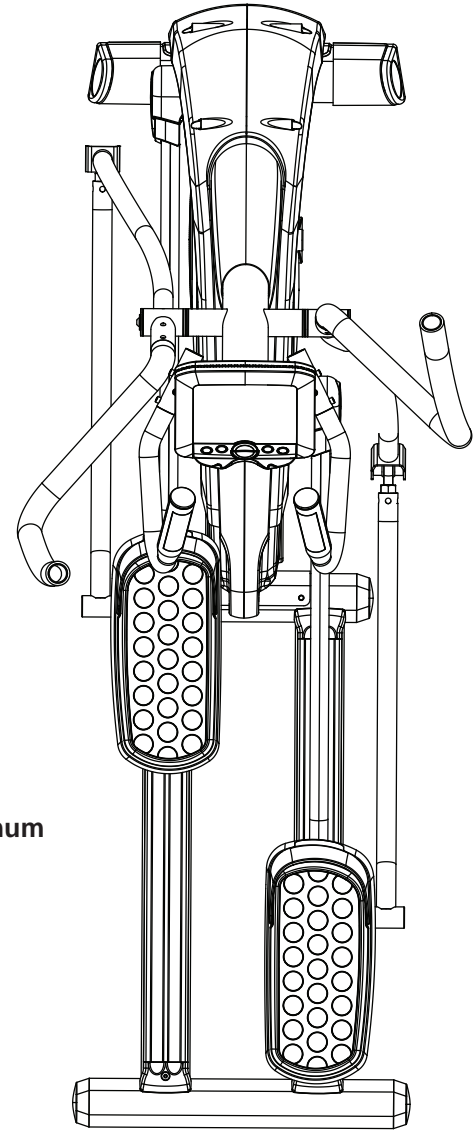

Wheel tracks must be kept clean of debris for optimum operation and product longevity.

 **KeysFitness** **Workout Information**
www.keysfitness.com



WARNING!

Before beginning this or any exercise program, you should consult your physician. This is especially important for individuals over the age of 35 or individuals with pre-existing health problems. Flexibility is a key to fitness. Stretch all major muscle groups at least two to three times per week after a 5 to 10 minute warmup. Stretch just to the point of a gentle tug. If you have back, joint, or other health problems, talk to your doctor first



Prone on Elbows

Lie on your stomach with your feet together. Rest on your forearms with your elbows directly under your shoulders. Relax lower back and abdomen into the floor. Hold for 30-60 seconds or until muscles feel looser



Supine Lumbar Rotation

Lie on your back with your knees bent. Keeping your knees together against the floor, roll your knees to one side until you feel a stretch in your back or hip. Hold for 30-60 seconds or until muscles feel looser. Repeat on opposite side.



Knees to Chest

Lie on your back. Bend your knees, and lift your feet off the floor. Grasp your knees with your arms and pull your knees toward your chest. Hold for 20 Repeat three to five times..



Cat and Camel

Rest on your hands and knees. Round your back by contracting your abdominal muscles and tucking in your pelvis; hold for five seconds. Then allow your back to sag toward the floor as you lift your chest and head; hold for five seconds. Repeat the combination 10 times.



Cervical Side Bends

Tilt your head gently toward one shoulder, keeping your shoulders level and your face pointed straight ahead. Hold for five seconds, then tilt your head toward the other shoulder. and hold for five seconds. Repeat five times on each side.



Shoulder Circles

In a smooth, continuous motion, make a circle with your shoulders: Raise them up towards your ears, pull them together behind you, lower them to a resting position, then roll them forward. Repeat then roll them forward. Repeat 10 times.



Wrist Extensor

Extend your right arm in front of you with your palm up and your elbow straight. Point your fingertips toward the floor by bending at the wrist. Using your left hand, pull the back of your right hand toward you gently. Hold for 20 seconds; repeat three to five times with each arm.



Wrist Flexor

Extend your right arm in front of you, palm down, elbow straight. Point your fingertips toward the floor by bending at the wrist. Using your left hand, pull your right palm toward you gently. Hold for 20 seconds; repeat three to five times with each arm.



Triceps Stretch

Place your right hand behind your head, palm facing your head. With your left hand, grasp your right elbow and pull downward until you feel a stretch in the back of your right arm. Hold for 20 seconds; repeat three to five times with each arm.



One-Arm Pectoralis Stretch

Stand against an immobile structure like a wall or a tree. While facing the wall, raise your right hand out to your side at chest height, palm against the wall. Turn your body toward the left, away from the wall and your extended arm, until you feel a stretch. Hold for 20 seconds; repeat three to five times with each arm.



Piriformis Stretch

Lie on your back. Bend your right knee and lift it halfway to your chest. Grasp your knee with your left hand and pull it toward your left shoulder, keeping both buttocks against the floor. Hold for 20 seconds; repeat three to five times with each leg.



Groin (Adductors) Stretch

Sitting with your back straight, bring the soles of your feet together. Let your knees lower toward the floor. Hold for 30-60 seconds or until muscles feel looser.



Calf Stretch

Face a solid structure such as a wall with your left foot ahead of your right, toes straight ahead. Bend your left knee, press your hips forward, and lean into the wall. Keep both heels down, your right leg straight, and your left knee over your ankle. Hold for 20 seconds; repeat three to five times with each leg.



Standing Quadriceps Stretch

Steady yourself with one hand. With the other, grab outside leg at ankle, keeping body straight from knee to hip. Gently pull foot up and towards the buttocks until you feel a stretch along the front of the thigh. Thigh should be pulled straight back and not drift to outside. Hold 20-30 seconds. For variation, grab opposite ankle (i.e., grab right ankle with left hand). Do two to three repetitions per leg.



Achilles Stretch

Face the wall with your left foot ahead of your right, toes straight ahead. Bend both knees, press your hips forward, and lean into the wall. Keep both heels down and both knees in line with your feet. Hold for 20 seconds; repeat three to five times with each leg.

 **KeysFitness** **Parts Information**
www.keysfitness.com





www.keysfitness.com

KF-E2.0 Parts List Rev A

Ref #	Description	Qty	Ref #	Description	Qty
A1	MAIN FRAME	1	F1-15	PEDAL JOINT	1
A1-1	SCREW	1	F1-16	WASHER(M10)	1
A1-2	UPPER IRON (T=3.0)	1	F1-17	WASHER(M10X20X2.3t)	1
A1-3	LOWER IRON (T=3.0)	1	F1-18	NUT(M10)	1
A1-4	SENSOR WIRE	1	F1-19	METAL BUSHING	2
A1-5	DC CORD	1	F1-20	FIXING SPACER	1
A2	SENSOR WIRE	1	F1-21	WASHER(M8X28X2.0t)	1
A2-1	CROSSHEAD SCREW FOR AXLE(M6X10)	4	F1-22	SPRING(M8)	3
A2-2	SCREW(M6X14L)	3	F1-23	SCREW(M8X20L)	1
A2-3	WASHER(M6X16X1.5T)	3	F1-24	SCREW(M8X78L)	1
A2-4	BUSHING(9X6.1X5.3L)	3	F1-25	SPRING (M8)	1
A3	DRIVE WHEEL	1	F1-26	WASHER (M8X16X1.2t)	1
A3-1	AXLE (19.98X146.6L)	1	F1-27	NUT (M8)	1
A3-2	CROSSHEAD SCREW FOR AXLE (M6X18L)	4	F1-28	BUSHING	1
A3-3	MAGNET	1	F1-29	WHEEL(70)	2
A3-4	CLIP (C21)	2	F2-1	PEDAL TUBE (LEFT)	1
A3-5	BEARING FOR AXLE (6004ZZ)	2	F2-3	UNIVERSAL JOINT	1
A4	BELT(69J-1428)	1	F2-9	CUSHION PAD	1
A5	FLYWHEEL (# 260X10Kg)	1	F2-10	SCREW(M5X12L)	6
A5-2	HOUSING FOR MAGNET	1	F2-11	PEDAL	1
A5-3	SCREW(M8X52L)	1	F2-12	SCREW (M4X20L)	3
A5-4	NUT(M6)	4	F2-13	FRONT COVER FOR PEDAL	1
A5-5	NUT(M8)	1	F2-14	PEDAL TUBE (LEFT)	1
A5-6	CLIP(C12)	2	F2-15	NUT(M10)	1
A5-7	BEARING(6001ZZ)	2	F2-16	WASHER(M10X20X2.3t)	1
A5-8	WHEEL AXLE(12X120L)	1	F2-17	WASHER(M10)	1
A5-9	WASHER (M10X21X2.0t)	2	F2-18	JOINT FOR PEDAL TUBE	1
A5-10	PRESSING SPRING	1	F2-19	BEARING(6003ZZ)	2
A5-11	NUT(3/8X26)	2	F2-20	WHEEL(70)	2
A5-12	SPRING	1	F2-21	BUSHING	1
A5-13	BEARING(6203ZZ)	2	F2-22	NUT (M8)	1
A5-14	CLIP(C17)	1	F2-23	SCREW(M8X20L)	1
A5-15	WASHER(M6)	4	F2-25	SPRING(M8)	3
A6	TENSION CONNECTOR	1	F2-26	WASHER(M8X28X2.0t)	1
A6-1	TENSION CABLE	1	F2-27	FIXING SPACER	1
A6-2	NUT	1	F2-28	METAL BUSHING	2
A7	CRANK (R)	1	F2-29	SCREW(M8X78L)	1
A8	CRANK (L)	1	F2-30	SPRING(M8)	1
A9	SCREW (M5X20L)	16	F2-31	WASHER (M8X16X1.2t)	1
A9-1	NUT (M10XP1.0)	2	F2-32	WASHER(M8X16X1.2)	4
A9-2	TURNING CONNECTOR	1	G1	FRONT HANDLEBAR(RIGHT)	1
A9-3	TURNING CONNECTOR	1	G1-1	HAND PULSE SENSOR WIRE	1
A9-4	TURING PLATE (R)	1	G1-2	SCREW (M3X35L)	2
A9-5	TURING PLATE (L)	1	G1-3	HAND PULSE	1
A10	CHAIN COVER (R)	1	G1-4	HAND PULSE	1
A11	CHAIN COVER (L)	1	G1-5	END CAP	1
A12	SCREW(M4X25)	8	G1-6	END CAP	1
A12-1	SCREW(M4X15)	2	G1-7	PAD FOR HAND PULSE	1
A13	SCREW (#10-32 X3/4)	4	G1-8	PAD FOR HAND PULSE	1
B	FRONT STABILIZER	1	G2	FRONT HANDLEBAR(LEFT)	1
B1	ADJUSTED END	2	G2-1	HAND PULSE SENSOR WIRE	1
B2	IRON	2	G2-2	SCREW(M3X35L)	2
B3	END CAP(R)	1	G2-3	HAND PULSE	1
B4	END CAP(L)	1	G2-4	HAND PULSE	1
B5	WHEEL	2	G2-5	END CAP	1
B6	SCREW (#8-32 X5/8)	4	G2-6	END CAP	1
C	SLIDE TRACK	1	G2-7	PAD FOR HAND PULSE	1
C1	ADJUSTED END	2	G2-8	PAD FOR HAND PULSE	1
C2	IRON	4	H	DECORATION COVER	1
C3	END CAP	4	J	MONITOR	1
C4	DECORTATION COVER FOR TRACK	4	J1	SCREW	2
C5	SCRREW (#10-32 X3/4)	4	K1	WATER BOTTLE	1
C6	SCREW(M5X13L)	6	K2	BOTTLE HONDEL	1
C7	WASHER (M5X15X1.5)	6	L-(L)	DECORATION COVER OF PEDAL TUBE	1
C8	NUT (M5)	6	L-(R)	DECORATION COVER OF PEDAL TUBE	1
C9	ALUMINUM TRACKING	2	M	ADAPTOR	1
D	CENTRAL SUPPORT TUBE	1	N1	SCREW (M8X58)	2
D1-1	HAND PULSE SENSOR WIRE	1	N2	SPRING (M8X70)	2
D2	SNNSOR WIRE	1	N3	SCREW(M8X20)	8
D2-1	HAND PULSE SENSOR WIRE	1	N4	SCREW (M10X112L)	2
D3	END CAP	6	N5	SCREW(M5X20)	2
E1	SIDE HANDLE BAR(R)	1	N6	SCREW(M6X10)	6
E1-1	SPONGE	1	N7	SCREW(M8X15)	4
E1-2	END CAP	1	N8	SCREW(M8X20)	3
E2	SIDE HANDLE BAR(L)	1	N10	SCREW(M4X10)	6
E2-1	SPONGE	1	N13	SPRING WASHER(M8)	19
E2-2	END CAP	1	N14	WASHER(M8X16X1.2)	16
F1	PEDAL TUBE (RIGHT)	1	N15	WASHER(M10X22X1.5)	2
F1-3	UNIVERSAL JOINT (M16)	1	N17	SPRING WASHER(M10)	2
F1-8	CUSHION PAD	1	N18	BUSHING	4
F1-9	SCREW (M5X12L)	6	N20	WASHER(M8X22X2.0)	1
F1-10	PEDAL	1	N21	WASHER(M8X38X2.0)	2
F1-11	DECORATION COVER FOR FRONT PEDAL	1	N22	NUT (M8)	2
F1-12	SCREW (M4X20L)	3	P1	RIGHT MOVING HANDLE BAR	1
F1-13	PEDAL TUBE (RIGHT)	1	P2	LEFT MOVING HANDLE BAR	1
F1-14	BEARING(6003ZZ)	2	#	BOLT PACK	1

32 Parts List

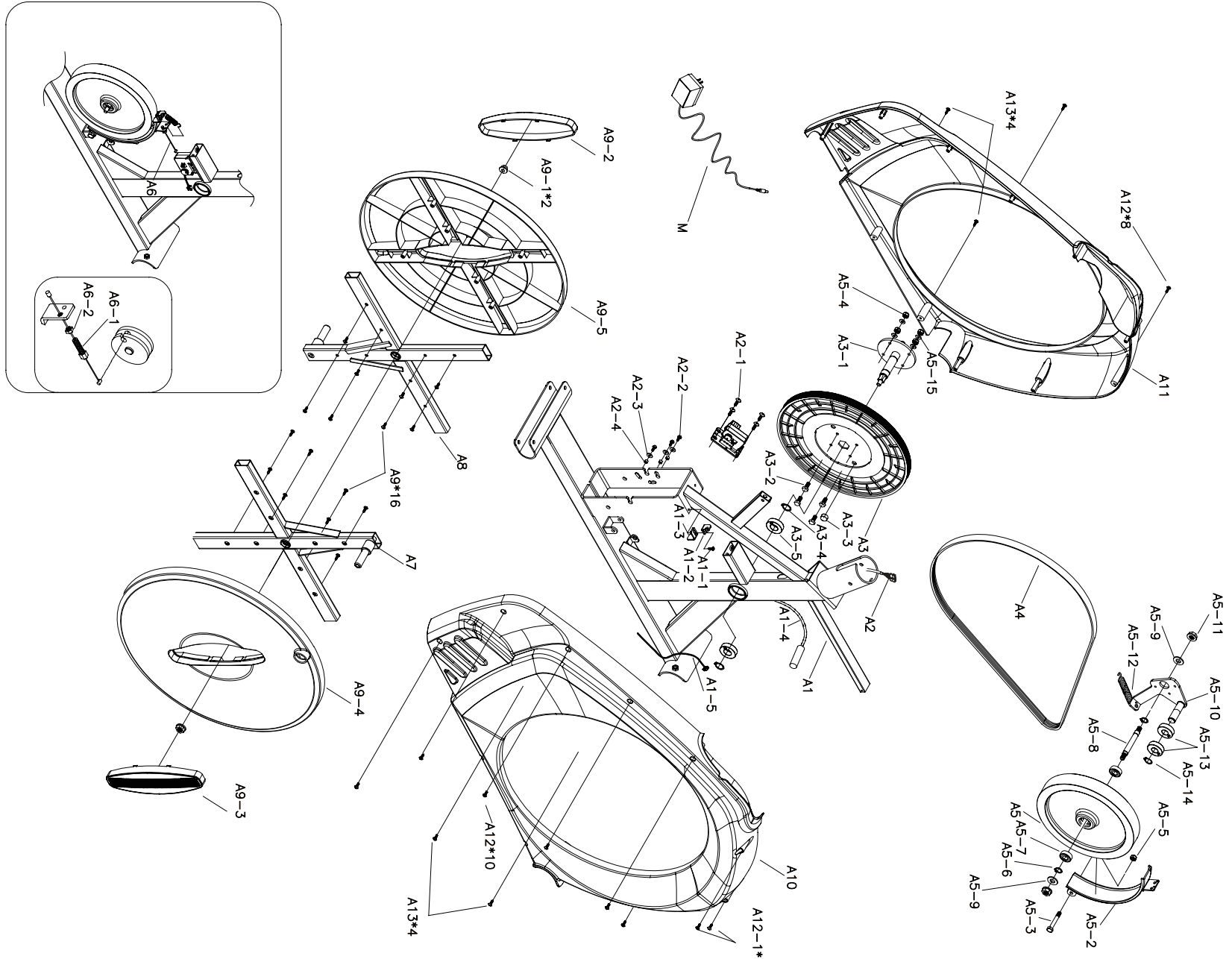

Residential and Personal Use Limited Warranty

PLEASE READ THESE WARRANTY TERMS AND CONDITIONS FULLY AND CAREFULLY BEFORE USING YOUR Keys Fitness EQUIPMENT. BY USING THE EQUIPMENT, YOU ARE CONSENTING TO BE BOUND BY THE FOLLOWING TERMS AND CONDITIONS.

Frame: Lifetime **Parts:** 3 years

Labor: 1 year

Limited Warranty

This Limited Warranty applies in the United States and Canada to Products manufactured or distributed by Keys Fitness, L.P. under the Keys Fitness ("Keys Fitness Products") brand name (as used herein, the "Product" or "Products"). The warranty period to the original purchaser is listed above, and commences on the date of original purchase of the product, unless otherwise authorized by Keys Fitness Products. Keys Fitness Products warrants that the Product purchased from Keys Fitness Products or from an authorized Keys Fitness reseller "dealer" (for residential or personal use only, unless otherwise authorized by Keys Fitness Products in writing), is free from defects in Materials and Workmanship relevant to the functionality of the Product at initial startup, under normal use, and during the applicable warranty period, unless otherwise determined by Keys Fitness Products.

This warranty excludes expendable parts if primary cause for warranty claim is wear. Expendable parts pertain to components on the Product that are prone to normal wear and tear. These items vary by Product, and can include (but not limited to) hand grips, skid pads, pedals, pedal straps, poly-v belts, console overlays, toggle switch/button overlays, (luster free or dull) ekg plates, decals, and any other items that are not essential to the operation of the Product, unless otherwise determined by Keys Fitness Products.

This warranty extends only to you, the original purchaser. It is not transferable to anyone who subsequently purchases (or receives as a gift) the Product from you. Your sales receipt, showing the date/place of purchase and serial number (if applicable) of the Product, is your proof of purchase, and may be required by Keys Fitness Products any time a warranty parts (or service) claim is made or if no warranty record exists for the product.

Exclusive Remedies

During the warranty period listed above, Keys Fitness Products will repair a Product by correcting any minor issues (either by phone or online support) that might be causing the Product failure. Should a technical service and support representative be unable to correct the issue, Keys Fitness Products may replace the parts (with new parts or at the option of Keys Fitness Products, with serviceable used parts, that are equivalent to new parts in performance) that become defective, malfunction, or otherwise fail to conform to this Limited Warranty under normal use.

Replacement parts shall be warranted for 30 days from the shipment reception date or through the end of the 'replaced' part warranty period, whichever is longer. Any replacement parts, required past the warranty period listed above, shall be subject to purchase at retail price, plus any added shipping and handling charges associated to the delivery of the part. Note that replacement parts may be available only through the lifetime (as defined) of the Product. In conforming to this warranty, Keys Fitness Products (as the manufacturer) reserves the right to change manufacturers or vendors of any part to cover the existing warranty.

Keys Fitness Products may also provide service (if deemed necessary and if applicable) at no charge to you during (and not to exceed) the service warranty period listed above, in an attempt to repair the Product. Should the Product require service at your request or out of the limited warranty period, Keys Fitness Products can furnish contact information for local (to your area) Keys Fitness Products authorized service providers. Service quotes, costs, and scheduling will be strictly dependent on service provider rates and mutual (consumer/provider) service agreements. Keys Fitness Products is not responsible for any service repair costs accrued through the use of authorized Keys Fitness Products service providers at your request or out of the limited warranty period (without written consent from Keys Fitness Products), beyond the limitations outlined on this warranty.

Replacements and Returns

If after a reasonable number of attempts, a defect has not been repaired (or the Product is deemed non-repairable by Keys Fitness Products technical service and support staff), Keys Fitness Products, based on a case by case review, may opt to replace the Product, or recommend an alternate resolution, such as a warranty buy-out (Product cost, subject to deduction of a reasonable charge for usage) or a credit. Keys Fitness Products, as a manufacturer, reserves the right to replace the Product with a Factory-Reconditioned Product that meets or exceed standards comparable to those of the replaced Product.

The warranty covering the replacement Product shall expire on the date the original warranty for the replaced Product would have expired, unless otherwise determined by Keys Fitness Products.

Conditions and Restrictions

This warranty DOES NOT (A) cover shipping and handling charges, export taxes, custom duties and taxes, or any other charges associated with transportation of the parts or Product, beyond the initial courtesy period of 60 days from original date of purchase of the Product; (B) extend to Products not purchased from Keys Fitness Products or from an authorized Keys Fitness Products reseller; (C) extend to Products purchased from online auction sites; (D) cover any extended, additional, or third party warranties if not offered exclusively by Keys Fitness Products in writing; (E) cover Products installed at fee based facilities/commercial environments (gyms, homes used as wellness centers, etc.); (F) cover Products installed in light institutional environments (non fee-based facilities include for example, and not be way of limitation, fire houses, police departments, rehab centers, hospitals, clinics, apartment complexes, club houses, etc.); (G) cover service calls to correct installation, perform maintenance, or instruct owners on how to use the equipment; or (H) cover a Product on which the serial number has been purposefully or accidentally defaced or removed and there is no proof of purchase available (if serial number is applicable), unless authorized by Keys Fitness Products in writing or otherwise stated on this warranty.

This Limited Warranty becomes void for Products that have been damaged or rendered defective as a result of (a) accident, misuse, or abuse (including but not limited to exceeding the Keys Fitness Products listed, maximum weight limit); (b) use of parts not manufactured or sold by Keys Fitness Products; (c) modification of the Product; (d) normal wear and tear; (e) operation on incorrect power supplies; (f) ***failure to perform (or performing improper) maintenance; (g) service by anyone other than Keys Fitness Products, or an authorized Keys Fitness Products warranty service provider; (h) floods, fires, earthquakes, lightning strikes, power surges, and other unavoidable acts of nature; (i) residential mis-wires; or (k) incorrect setup, installation, or assembly. Should any Product (submitted for warranty parts replacement) be found ineligible under the terms outlined on this warranty, an estimate for parts purchase (if available) can be furnished at your request.

* Parts is herein defined exclusively, for all intents and purposes, and pertaining to this Limited Manufacturer Warranty, as components or Materials essential to the functionality of the Product.

**Lifetime of a Product, is herein defined exclusively, for all intents and purposes, and pertaining to this Limited Manufacturer Warranty, as the time period 7 years beyond the end of production cycle of a Product in question.

Disclaimer and Release

EXCEPT AS EXPRESSLY SET FORTH IN THIS WARRANTY, Keys Fitness Products MAKES NO OTHER WARRANTIES, EXPRESSED OR IMPLIED, INCLUDING ANY IMPLIED WARRANTIES OF MERCHANTABILITY AND FITNESS FOR A PARTICULAR PURPOSE. Keys Fitness Products EXPRESSLY DISCLAIMS ALL WARRANTIES NOT STATED IN THIS LIMITED WARRANTY. ANY IMPLIED WARRANTIES THAT MAY BE IMPOSED BY LAW ARE LIMITED TO THE TERMS OF THIS LIMITED WARRANTY. NEITHER Keys Fitness Products NOR ANY OF ITS AFFILIATES SHALL BE RESPONSIBLE FOR INCIDENTAL OR CONSEQUENTIAL DAMAGES. SOME STATES DO NOT ALLOW LIMITATIONS ON IMPLIED WARRANTIES OR THE EXCLUSION OR LIMITATION OF INCIDENTAL OR CONSEQUENTIAL DAMAGES, SO THE ABOVE LIMITATIONS OR EXCLUSIONS MAY NOT APPLY TO YOU. THIS LIMITED WARRANTY GIVES YOU SPECIFIC LEGAL RIGHTS AND YOU MAY ALSO HAVE OTHER RIGHTS THAT MAY VARY FROM STATE TO STATE. THIS IS THE ONLY EXPRESS WARRANTY APPLICABLE TO Keys Fitness Products-BRANDED PRODUCTS. Keys Fitness Products NEITHER ASSUMES NOR AUTHORIZES ANYONE TO ASSUME FOR IT ANY OTHER EXPRESS WARRANTY.



www.keysfitness.com

Keys Fitness, L.P.

4009 Distribution Drive, Suite 250

Garland, Texas 75041

Customer Service: 1-800-340-0482

Free Manuals Download Website

<http://myh66.com>

<http://usermanuals.us>

<http://www.somanuals.com>

<http://www.4manuals.cc>

<http://www.manual-lib.com>

<http://www.404manual.com>

<http://www.luxmanual.com>

<http://aubethermostatmanual.com>

Golf course search by state

<http://golfingnear.com>

Email search by domain

<http://emailbydomain.com>

Auto manuals search

<http://auto.somanuals.com>

TV manuals search

<http://tv.somanuals.com>