

[Table of Contents](#)



# FS-1900

**Ecosys** Page Printer

**Operation Guide**

---

---

## Caution on Installation

---

NO LIABILITY IS ASSUMED FOR ANY DAMAGE CAUSED BY IMPROPER INSTALLATION.

## Notice on Software

---

SOFTWARE USED WITH THIS PRINTER MUST SUPPORT THE PRINTER'S EMULATION MODE. The printer is factory-set to emulate the PCL. The emulation mode can be changed by following the procedures described in [Chapter 1](#).

## Notice on This Guide

---

The information in this guide is subject to change without notification. Additional pages may be inserted in future editions. The user is asked to excuse any technical inaccuracies or typographical errors in the present edition.

No responsibility is assumed if accidents occur while the user is following the instructions in this guide. No responsibility is assumed for defects in the printer's firmware (contents of its read-only memory).

This guide, any copyrightable subject matter sold or provided with or in connection with the sale of the page printer, are protected by copyright. All rights are reserved. Copying or other reproduction of all or part of this guide, any copyrightable subject matter without the prior written consent of Kyocera Corporation is prohibited. Any copies made of all or part of this guide, any copyrightable subject matter must contain the same copyright notice as the material from which the copying is done.

## Regarding Tradenames

---

PRESCRIBE is a registered trademark of Kyocera Corporation. KPDL and KIR (Kyocera Image Refinement) are trademarks of Kyocera Corporation.

Diablo 630 is a product of Xerox Corporation. IBM Proprinter X24E is a product of International Business Machines Corporation. Epson LQ-850 is a product of Seiko Epson Corporation.

Hewlett-Packard, PCL, and PJI are registered trademarks of Hewlett-Packard Company. Centronics is a trade name of Centronics Data Computer Inc. PostScript is a registered trademark of Adobe Systems Incorporated. Macintosh is a registered trademark of Apple Computer, Inc. Microsoft, Windows, and Windows NT are registered trademarks of Microsoft Corporation. PowerPC and Microdrive are trademarks of International Business Machines Corporation. CompactFlash is a trademark of SanDisk Corporation. ENERGY STAR is a U.S. registered mark. All other brand and product names are registered trademarks or trademarks of their respective companies.

This Kyocera Mita page printer uses PeerlessPrintXL to provide the HP LaserJet compatible PCL6 language emulation. PeerlessPrintXL is a trademark of The Peerless Group, Redondo Beach, CA 90278, U.S.A.

This product was developed using the Tornado™ Real Time Operating System and Tools from Wind River Systems.

**AGFA**  This product contains UFST™ and MicroType® from Agfa Corporation.



---

## IBM PROGRAM LICENSE AGREEMENT

---

THE DEVICE YOU HAVE PURCHASED CONTAINS ONE OR MORE SOFTWARE PROGRAMS ("PROGRAMS") WHICH BELONG TO INTERNATIONAL BUSINESS MACHINES CORPORATION ("IBM"). THIS DOCUMENT DEFINES THE TERMS AND CONDITIONS UNDER WHICH THE SOFTWARE IS BEING LICENSED TO YOU BY IBM. IF YOU DO NOT AGREE WITH THE TERMS AND CONDITIONS OF THIS LICENSE, THEN WITHIN 14 DAYS AFTER YOUR ACQUISITION OF THE DEVICE YOU MAY RETURN THE DEVICE FOR A FULL REFUND. IF YOU DO NOT SO RETURN THE DEVICE WITHIN THE 14 DAYS, THEN YOU WILL BE ASSUMED TO HAVE AGREED TO THESE TERMS AND CONDITIONS.

The Programs are licensed not sold. IBM, or the applicable IBM country organization, grants you a license for the Programs only in the country where you acquired the Programs. You obtain no rights other than those granted you under this license.

The term "Programs" means the original and all whole or partial copies of it, including modified copies or portions merged into other programs. IBM retains title to the Programs. IBM owns, or has licensed from the owner, copyrights in the Programs.

### 1. License

Under this license, you may use the Programs only with the device on which they are installed and transfer possession of the Programs and the device to another party.

If you transfer the Programs, you must transfer a copy of this license and any other documentation to the other party. Your license is then terminated. The other party agrees to these terms and conditions by its first use of the Program.

You may not:

- 1) use, copy, modify, merge, or transfer copies of the Program except as provided in this license;
- 2) reverse assemble or reverse compile the Program; or
- 3) sublicense, rent, lease, or assign the Program.

### 2. Limited Warranty

The Programs are provided "AS IS."

THERE ARE NO OTHER WARRANTIES COVERING THE PROGRAMS (OR CONDITIONS), EXPRESS OR IMPLIED, INCLUDING, BUT NOT LIMITED TO, THE IMPLIED WARRANTIES OF MERCHANTABILITY AND FITNESS FOR A PARTICULAR PURPOSE.

Some jurisdictions do not allow the exclusion of implied warranties, so the above exclusion may not apply to you.

### 3. Limitation of Remedies

IBM's entire liability under this license is the following:

- 1) For any claim (including fundamental breach), in any form, related in any way to this license, IBM's liability will be for actual damages only and will be limited to the greater of:
  - a) the equivalent of U.S.\$25,000 in your local currency; or
  - b) IBM's then generally available license fee for the Program

This limitation will not apply to claims for bodily injury or damages to real or tangible personal property for which IBM is legally liable.

IBM will not be liable for any lost profits, lost savings, or any incidental damages or other economic consequential damages, even if IBM, or its authorized supplier, has been advised of the possibility of such damages. IBM will not be liable for any damages claimed by you based on any third party claim. This limitation of remedies also applies to any developer of Programs supplied to IBM. IBM's and the developer's limitations of remedies are not cumulative. Such developer is an intended beneficiary of this Section. Some jurisdictions do not allow these limitations or exclusions, so they may not apply to you.

### 4. General

You may terminate your license at any time. IBM may terminate your license if you fail to comply with the terms and conditions of this license. In either event, you must destroy all your copies of the Program. You are responsible for payment of any taxes, including personal property taxes, resulting from this license. Neither party may bring an action, regardless of form, more than two years after the cause of action arose. If you acquired the Program in the United States, this license is governed by the laws of the State of New York. If you acquired the Program in Canada, this license is governed by the laws of the Province of Ontario. Otherwise, this license is governed by the laws of the country in which you acquired the Program.

---

## Typeface Trademark Acknowledgement

---

All resident fonts in this printer are licensed from Agfa Corporation.

Helvetica, Palatino and Times are registered trademarks of Linotype-Hell AG.

ITC Avant Garde Gothic, ITC Bookman, ITC ZapfChancery and ITC Zapf Dingbats are registered trademarks of International Typeface Corporation.

## Agfa Japan License Agreement

---

1. "Software" shall mean the digitally encoded, machine readable, scalable outline data as encoded in a special format as well as the UFST Software.
2. You agree to accept a non-exclusive license to use the Software to reproduce and display weights, styles and versions of letters, numerals, characters and symbols ("Typefaces") solely for your own customary business or personal purposes at the address stated on the registration card you return to Agfa Japan. Under the terms of this License Agreement, you have the right to use the Fonts on up to three printers. If you need to have access to the fonts on more than three printers, you need to acquire a multi-user license agreement which can be obtained from Agfa Japan. Agfa Japan retains all rights, title and interest to the Software and Typefaces and no rights are granted to you other than a License to use the Software on the terms expressly set forth in this Agreement.
3. To protect proprietary rights of Agfa Japan, you agree to maintain the Software and other proprietary information concerning the Typefaces in strict confidence and to establish reasonable procedures regulating access to and use of the Software and Typefaces.
4. You agree not to duplicate or copy the Software or Typefaces, except that you may make one backup copy. You agree that any such copy shall contain the same proprietary notices as those appearing on the original.
5. This License shall continue until the last use of the Software and Typefaces, unless sooner terminated. This License may be terminated by Agfa Japan if you fail to comply with the terms of this License and such failure is not remedied within thirty (30) days after notice from Agfa Japan. When this License expires or is terminated, you shall either return to Agfa Japan or destroy all copies of the Software and Typefaces and documentation as requested.
6. You agree that you will not modify, alter, disassemble, decrypt, reverse engineer or decompile the Software.
7. Agfa Japan warrants that for ninety (90) days after delivery, the Software will perform in accordance with Agfa Japan-published specifications, and the diskette will be free from defects in material and workmanship. Agfa Japan does not warrant that the Software is free from all bugs, errors and omissions.  
THE PARTIES AGREE THAT ALL OTHER WARRANTIES, EXPRESSED OR IMPLIED, INCLUDING WARRANTIES OF FITNESS FOR A PARTICULAR PURPOSE AND MERCHANTABILITY, ARE EXCLUDED.
8. Your exclusive remedy and the sole liability of Agfa Japan in connection with the Software and Typefaces is repair or replacement of defective parts, upon their return to Agfa Japan.  
IN NO EVENT WILL AGFA JAPAN BE LIABLE FOR LOST PROFITS, LOST DATA, OR ANY OTHER INCIDENTAL OR CONSEQUENTIAL DAMAGES, OR ANY DAMAGES CAUSED BY ABUSE OR MISAPPLICATION OF THE SOFTWARE AND TYPEFACES.
9. New York, U.S.A. law governs this Agreement.
10. You shall not sublicense, sell, lease, or otherwise transfer the Software and/or Typefaces without the prior written consent of Agfa Japan.
11. Use, duplication or disclosure by the Government is subject to restrictions as set forth in the Rights in Technical Data and Computer Software clause at FAR 252-227-7013, subdivision (b)(3)(ii) or subparagraph (c)(1)(ii), as appropriate. Further use, duplication or disclosure is subject to restrictions applicable to restricted rights software as set forth in FAR 52.227-19 (c)(2).
12. YOU ACKNOWLEDGE THAT YOU HAVE READ THIS AGREEMENT, UNDERSTAND IT, AND AGREE TO BE BOUND BY ITS TERMS AND CONDITIONS. NEITHER PARTY SHALL BE BOUND BY ANY STATEMENT OR REPRESENTATION NOT CONTAINED IN THIS AGREEMENT. NO CHANGE IN THIS AGREEMENT IS EFFECTIVE UNLESS WRITTEN AND SIGNED BY PROPERLY AUTHORIZED REPRESENTATIVES OF EACH PARTY. BY OPENING THIS DISKETTE PACKAGE, YOU AGREE TO ACCEPT THE TERMS AND CONDITIONS OF THIS AGREEMENT.

## Cautions for Toner Handling

---

- Do not incinerate toner and toner containers. Dangerous sparks may cause burn.
- Never open the toner container or waste toner box.
- Make sure not to inhale the toner, and not to rub your eyes or touch your mouth with the hands stained with the toner. And make sure not to stick to your skin.
- For the disposal of old toner container and waste toner box, consult your dealer. Or dispose of the toner or toner containers in accordance with Federal, state and Local rules and regulations.
- Keep away the toner container and the waste toner box from children.

# Contents

<b>Introduction .....</b>	<b>ix</b>
Features .....	x
For More Information.....	xii
Guide to the Operation Guide.....	xii
<b>Chapter 1 Using the Operator Panel .....</b>	<b>1-1</b>
Understanding the Operator Panel .....	1-2
Message Display .....	1-2
Interface Indicator .....	1-3
Paper Size Indicator.....	1-3
Paper Type Indicator .....	1-4
READY, DATA, and ATTENTION Indicators .....	1-4
Keys .....	1-5
Menu System Road Map.....	1-6
Printing Test Pages .....	1-12
Menu Map .....	1-12
Status Page.....	1-14
Service Status Page .....	1-18
Network Card Interface Status Page.....	1-19
Font Lists.....	1-21
Received Data Dumping.....	1-23
Paper Handling.....	1-24
Setting the Paper Size .....	1-24
Setting the Paper Size in Paper Cassette .....	1-24
Setting the Paper Size in MP Tray .....	1-28
Setting the Paper Type .....	1-30
Setting the Paper Type in Paper Cassette .....	1-30
Setting the Paper Type in MP Tray .....	1-31
Custom Paper Type .....	1-32
Resetting the Custom Paper Type .....	1-36
MP Tray Mode.....	1-37
Selecting the Paper Feed Source .....	1-38
Output Stack.....	1-39
Overriding A4 and Letter Size Difference.....	1-40

Pagination .....	1-41
Emulation .....	1-41
Changing the Emulation .....	1-41
Alternative Emulation for KPD L Emulation .....	1-42
Printing KPD L Errors .....	1-43
Font .....	1-44
Default font .....	1-44
Default Font Size .....	1-46
Changing Type for Courier/Letter Gothic .....	1-47
Setting the Character Pitch for Courier/Letter Gothic .....	1-48
Code Set .....	1-49
Number of Copies .....	1-50
Printing Orientation .....	1-51
KIR (Kyocera Image Refinement) .....	1-52
Ecoprint .....	1-54
Resolution .....	1-55
e-MPS .....	1-56
Quick Copy .....	1-57
Proof and Hold .....	1-59
Printing a Private Job .....	1-61
Storing a Print Job .....	1-63
Printing a Code Job .....	1-65
Printing a List of Code Jobs .....	1-67
Retrieving Jobs from Virtual Mailbox (VMB) .....	1-68
Printing a List of VMB .....	1-69
e-MPS Configuration .....	1-70
Interface .....	1-74
Parallel Interface Mode .....	1-74
USB Interface Mode .....	1-75
Serial Interface Parameters .....	1-76
Network Interface Parameters .....	1-78
Operating the Storage Device .....	1-81
Activating the RAM Disk .....	1-81
Reading Data .....	1-83
Writing Data .....	1-84
Deleting Data .....	1-86
Reading Fonts from a CompactFlash Card .....	1-87
Formatting a Storage Device .....	1-88
Printing a List of Data Names .....	1-89

Configuration .....	1-91
Page Protect Mode .....	1-91
Linefeed (LF) Action .....	1-92
Carriage-Return (CR) Action .....	1-93
Wide A4 Pitch.....	1-94
Print Density .....	1-95
Total Printed Pages.....	1-96
Toner Counter Resetting .....	1-96
Message Language.....	1-97
Automatic Form Feed Timeout.....	1-99
Sleep Timer Setting .....	1-100
Printer Resetting .....	1-102
Resource Protection .....	1-103
Alarm (Buzzer) Setting.....	1-104
Auto Continue Setting .....	1-105
<b>Chapter 2 Paper Selection.....</b>	<b>2-1</b>
General Guidelines.....	2-2
Paper Availability .....	2-2
Paper Specifications.....	2-2
Selecting the Right Paper.....	2-3
Special Paper .....	2-7
Transparency (Overhead Projection Film) .....	2-7
Adhesive-Backed Labels.....	2-8
Paper Type .....	2-11
<b>Chapter 3 Maintenance .....</b>	<b>3-1</b>
Toner Container Replacement .....	3-2
Toner Container Replacement Interval.....	3-2
Replenishing Toner.....	3-3
Waste Toner Box Replacement .....	3-6
Replacing the Waste Toner Box.....	3-6
Cleaning .....	3-9
Cleaning the Charger Wire .....	3-9
Cleaning the Charger Grid.....	3-10
Paper Transfer Unit.....	3-12

<b>Chapter 4 Troubleshooting .....</b>	<b>4-1</b>
General Guide.....	4-2
Print Quality Problems .....	4-3
Indicators and Messages .....	4-6
Indicators.....	4-6
Maintenance Messages .....	4-7
Error Messages .....	4-10
Correcting a Paper Jam.....	4-12
Jam at the Paper Cassette or Inside the Printer .....	4-14
Paper Jam at the Option Duplexer .....	4-16
Paper Jam at the Option Sorter .....	4-18
Jam at the MP Tray.....	4-20
<b>Appendix A Fonts .....</b>	<b>A-1</b>
<b>Appendix B Options.....</b>	<b>B-1</b>
Available Options .....	B-2
Expanding the Printer Memory.....	B-3
Installing Option Units .....	B-9
PF-60 Paper Feeder .....	B-9
DU-60 Duplexer .....	B-12
SO-60 Sorter.....	B-15
EF-60 Envelope Feeder .....	B-21
PT-4/PT-60 Face-up Output Tray .....	B-25
Network Interface Card.....	B-26
Microdrive (Hard Disk).....	B-28
CompactFlash (Memory) Card.....	B-30
<b>Appendix C Host Computer Interface.....</b>	<b>C-1</b>
Parallel Interface .....	C-2
Parallel Interface Communication Modes .....	C-2
Interface Signals .....	C-2
USB Interface .....	C-5
Specifications .....	C-5
Interface Signals .....	C-5
Serial Interface (Option) .....	C-6
RS-232C Interface.....	C-6
RS-422A Interface.....	C-7



---

Contents

RS-232C/RS-422A Protocol .....	C-9
PRESCRIBE FRPO D0 Command.....	C-10
RS-232C Cable Connection .....	C-11
Obtain a Suitable RS-232C Cable.....	C-11
Connecting the Printer to the Computer .....	C-11
<b>Appendix D Specifications .....</b>	<b>D-1</b>
<b>Glossary .....</b>	<b>Glossary-1</b>
<b>Index .....</b>	<b>Index-1</b>

---

# Introduction

---

The Kyocera Mita page printer has many extremely desirable features. It was designed to make a contribution to a cleaner environment as well as to represent the latest generation of page printer technology.

This section contains the following subsections.

- **Features**
- **For More Information...**
- **Guide to the Operation Guide**

---

## Features

### **Ultra long life modules**

The drum, developer, and fuser have been designed for ultra long life.

### **Amorphous silicon drum**

The drum has been developed using Kyocera's unique ceramic technology using amorphous silicon.

### **KIR (Kyocera Image Refinement)**

This is Kyocera's original smoothing function. It uses software to enhance the printer's resolution and produce high-quality printing. The default setting is On.

### **Superb print quality**

Using 1200 dpi resolution in Fast 1200 mode, the printout is close to typeset quality. Also, with Kyocera Image Refinement (KIR) technology, high quality printing can be achieved even at 300 dpi and 600 dpi.

### **Large paper capacity**

Approximately 500 sheets can be loaded into the paper cassette, and about 100 sheets can be loaded into the MP tray.

### **Wide variety of print media**

As well as standard paper, the printer will print on transparency, labels and other types of special purpose media.

### **Sleep Mode**

Conserves energy during the printer's idle periods.

### **Ecoprint**

Extends the toner yield by reducing the amount of toner used on the page.

### **USB (Universal Serial Bus) Interface**

This printer supports USB Revision 1.1 standards. Connection to a computer with a USB interface gives a higher communication speed than parallel interface connection.

### **Standard Bi-directional Parallel Interface**

Supports high-speed data exchange with the computer.

---

### **Wide Variety of Available Fonts**

The printer comes with 80 PCL/PS compatible fonts and a line printer bitmap font installed.

### **PRESCRIBE Command Language**

PRESCRIBE provides features including advanced graphics capabilities that allow you to print any conceivable outline shape or solid form. Also provided are a variety of special effects, such as patterned fills, gray-scale shading, a user-accessible print image model, and multiple page orientations and print directions within the same page.

### **Job Retention**

Allows you to save print jobs onto the Microdrive installed in the printer. It print them out later at the operator panel. The following four types of job retention are available: quick copy, proof and hold, private printing, and stored jobs.

### **Display of printer messages in any of five languages**

English, French, German, Italian, or Spanish. As an option it is also possible to download the messages in other languages. Please contact your Kyocera Mita dealer.

### **Microdrive (hard disk unit) slot for various functions such as job retention, VMB, and more**

By saving print jobs onto the Microdrive, they can be printed out at the operator panel when desired. The electronic sort function can be used for much faster printing.

### **CompactFlash card slot for option fonts, macros, forms, etc.**

Data in the CompactFlash card can be selectively read from the printer's operator panel.

### **PDF417 Two-dimensional Barcode**

The printer includes a capability that allows the user to implement two-dimensional stacked barcode symbology PDF417 (Portable Data File 417).

### **SNMP compliance**

The printer complies with Simple Network Management Protocol (SNMP). The SNMP is used for providing and transferring management information (MIB) between the printer and the host computer.

### **Support for network printer monitor utility (KM-NET VIEWER)**

Allows network wide management of printers. See the readme file in the *Kyocera Mita Digital Library* CD-ROM (comes with the printer) for details.

---

## For More Information...

Item	Description
Installation Guide (paper manual)	Describes procedures from printer setup to printing a test page.
Operation Guide (this guide)	Guides you through topics concerning the operations and maintenance of the printer.
Printer Driver Guide	Describes how to install and set the printer driver. This manual is contained in the CD-ROM supplied with the printer.
PRESCRIBE Programming Manual	Describes how to use the PRESCRIBE commands and their parameters in detail for experienced users. This manual is contained in the CD-ROM supplied with the printer.
PDF417 Two-Dimensional Bar Code Implementation Manual	Includes a PDF417 overview and explains PRESCRIBE commands for use with two-dimensional barcodes. This manual is contained in the CD-ROM supplied with the printer.

## Guide to the Operation Guide

This *Operation Guide* has the following chapters:

### Chapter 1 Using the Operator Panel

This chapter explains the message display, indicators and keys on the operator panel, and how to make various settings from the operator panel.

### Chapter 2 Paper Selection

This chapter explains the types of paper that can be used with the printer.

### Chapter 3 Maintenance

This chapter explains how to replace the toner container, waste toner box, and how to care for your printer.

### Chapter 4 Troubleshooting

This chapter explains how to handle printer problems that may occur, such as paper jams.

### Appendix A Fonts

This appendix explains about fonts and lists the printer's internal fonts.

---

## Appendix B Options

This appendix explains how to expand the printer's memory and how to install each option unit.

## Appendix C Host Computer Interface

This appendix explains the pin assignment and specifications for the printer's parallel interface, USB interface, and optional serial interface.

## Appendix D Specifications

This appendix lists the printer's specifications.

## Glossary

This glossary explains the terminology used in this guide.

The following symbols are used to attract your attention in this guide. The symbols and their meanings are as follows:



Note

Indicates tips or advice useful for operation.



Caution

Indicates situations that are potentially hazardous to the human body or devices.



Warning

Indicates situations that are potentially extremely hazardous to the human body or devices.



Option

Indicates operations that can be performed or are effective only when the required option unit is installed.

---

# Chapter 1      **Using the Operator Panel**

---

This chapter explains the following topics:

- **Understanding the Operator Panel**
- **Printing Test Pages**
- **Paper Handling**
- **Pagination**
- **e-MPS**
- **Interface**
- **Operating the Storage Device**
- **Configuration**

## Understanding the Operator Panel

The operator panel has a LCD message display, three indicators, and eight keys.

Messages that appear on the display and functions of indicators and keys are explained in the sections that follows.

### Message Display

The message display gives information in the form of short messages. The eight messages listed below are displayed during normal warm-up and printing.

Other messages that may appear when the printer needs the operator's attention are explained in [Chapter 4](#).

Message	Meaning
Self test	The printer is self-testing after power-up.
Please wait	The printer is warming up and is not ready. When the printer is switched on for the first time after the toner container is installed, (Adding toner) also appears.
Ready	The printer is ready to print.
Processing	The printer is receiving data, generating graphics, reading a CompactFlash card/Microdrive, or printing.
Sleeping	The printer is in sleep mode. The printer wakes from sleep mode whenever the <b>GO</b> key on the operator panel is pressed, the cover is opened or closed, or data is received. The printer then warms up and goes online. The time that the printer takes to enter sleep mode depends on the sleep timer setting.
Cancelling data	Jobs inside the printer are being canceled. To cancel a job, see the table on page <a href="#">1-5</a> .
Waiting	The printer is waiting for the end-of-job command before printing the last page. Pressing the <b>GO</b> key allows you to obtain the last page immediately.
FormFeed Time Out	The printer is printing the last page after a waiting period.



## Interface Indicator



The interface indicator shows the interface that is currently used. It uses the following abbreviations:

PAR	Standard bi-directional parallel interface
USB	Standard USB interface
SER	Option serial interface (RS-232C)
OPT	Option network interface card
---	No interface is active.



Note

**Each interface has a timeout time of 30 seconds during which the other interface should wait to receive a print job. Even a print job has been complete on the interface, you should wait for this period until the other interface begins printing the job.**

## Paper Size Indicator



This indicator indicates the paper size of the current paper cassette. The following abbreviations are used to indicate the paper sizes.

Message Display	Paper Size	Message Display	Paper Size
A4	ISO A4 (21 × 29.7 cm)	EX	Executive (7-1/4 × 10-1/2 inches)*
A5	ISO A5 (14.8 × 21 cm)	#6	Commercial 6-3/4 (3-5/8 × 6-1/2 inches)*
A6	ISO A6 (10.5 × 14.8 cm)*	#9	Commercial 9 (3-7/8 × 8-7/8 inches)*
B5	JIS B5 (18.2 × 25.6 cm)	O2	Oficio II (8-1/2 × 13 inches)*
B6	JIS B6 (12.8 × 18.2 cm)*	ST	Statement (5-1/2 × 8-1/2 inches)*
LT	Letter (8-1/2 × 11 inches)	FO	Folio (210 × 330 mm)*
LG	Legal (8-1/2 × 14 inches)	HA	Japanese Postcard (10 × 14.8 cm)*
MO	Monarch (3-7/8 × 7-1/2 inches)*	OH	Return Postcard (20 × 14.8 cm)*
BU	Business (4-1/8 × 9-1/2 inches)*	Y2	Envelope (Youkei 2) (114 × 162 mm)*
DL	ISO DL (11 × 22 cm)*	Y4	Envelope (Youkei 4) (105 × 235 mm)*
C5	ISO C5 (16.2 × 22.9 cm)*	CU	Custom Size (14.8 × 21 cm to 21.6 × 35.6 cm)
b5	ISO B5 (17.6 × 25 cm)*		

\* With only the MP tray feeding.



Note

**While the printer is processing data, the SIZE indicator indicates the paper size selected by the application software.**

## Paper Type Indicator

This shows the paper type defined for the current paper cassette. Automatic cassette switching is available according to the paper type.

The paper type can be specified at the operator panel. See *Custom Paper Type* on page 1-32.

The following abbreviations are used to indicate the paper type.



Message Display	Paper Type	Message Display	Paper Type
None	Auto	ROUGH	Rough
PLAIN	Plain	LETTERHEA	Letterhead
TRNSPRNCY	Transparency*	COLOR	Color
PREPRINTE	Preprinted	PREPUNCH	Prepunched
LABELS	Labels*	ENVELOPE	Envelope*
BOND	Bond	CARDSTOCK	Cardstock*
RECYCLED	Recycled	CUSTOM1 (to 8)	Custom 1 (to 8)
VELLUM	Vellum*		

\* With only the MP tray feeding.

## READY, DATA, and ATTENTION Indicators

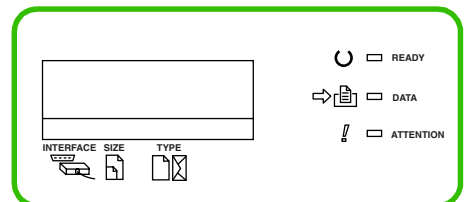
The following indicators light during normal operation and when the printer needs attention.



Indicator	Description
 <input type="checkbox"/> READY	<p><b>Flashing:</b> Indicates when an error occurs that you can clear by yourself.</p> <p><b>Lit:</b> Indicates that the printer is on-line. The printer prints received data.</p> <p><b>Off:</b> Indicates that the printer is off-line. Data can be received but will not be printed. Also indicates when printing is automatically stopped due to occurrence of an error.</p>
 <input type="checkbox"/> DATA	<p><b>Flashing:</b> Indicates data transfer is taking place.</p> <p><b>Lit:</b> Indicates either that data is being processed, or that data is being written to the memory card.</p>
 <input type="checkbox"/> ATTENTION	<p><b>Flashing:</b> Indicates when the printer needs maintenance attention or the printer is warming up (Please wait).</p> <p><b>Lit:</b> Indicates when a problem or an error occurs that you can clear by yourself. (For example, paper jam occurs.)</p>





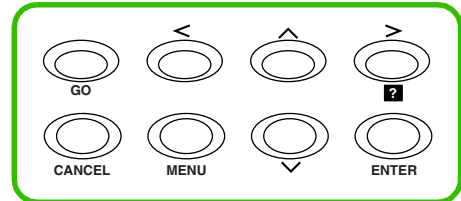



## Keys

The operator panel keys are used to configure the printer. Note the certain keys have the secondary function.



Note

Settings made with these keys effect only the interface currently in use.

Key	Function
	<ul style="list-style-type: none"> <li>• Switches the printer on-line and off-line.</li> <li>• Prints and feed out one page.</li> <li>• Cancels specific errors.</li> </ul>
	<ul style="list-style-type: none"> <li>• Cancels a printing job. To cancel, proceed as follows: <b>1</b> Check if Processing is displayed in the message display. <b>2</b> Press the <b>CANCEL</b> key. <b>3</b> Print Cancel? appears in the message display and then interface to be canceled. Parallel USB Serial (appears only when an option serial interface board kit is installed) Option (appears only when an option network interface card is installed) Press the <b>CANCEL</b> key again if you wish to stop the cancellation of printing.</li> <li><b>4</b> Select the interface to cancel using the ^ or v key and then press the <b>ENTER</b> key. Printing from the selected interface will stop. Cancelling data appears in the message display and printing stops after the current page is printed.</li> <li>• Resets numeric values, or cancels a setting procedure.</li> <li>• Used to stop the sounding of the alarm buzzer an error occurs.</li> </ul>
	<ul style="list-style-type: none"> <li>• When pressed during mode selection, terminates the setting and the printer returns to the Ready condition.</li> <li>• Used to select the emulation, font, character code set; to read an CompactFlash card, and more.</li> </ul>
	Used to access a desired item or enter numeric values. In some of the control procedures, the > and < keys are used to enter or exit a sub item.
	Used to access a desired item or enter of numeric values. In some of the control procedures, the > and < keys are used to enter or exit a sub item.
	Used as the < key in the mode selection function.
	<ul style="list-style-type: none"> <li>• Used as the &gt; key in the mode selection function.</li> <li>• Displays online help messages on the message display when paper jam errors occur. When pressed in the Ready condition, displays explanations of online help messages. When pressed while the online help is displayed, cancels the online help.</li> </ul>
	Finalizes numeric values and other selections.

## Menu System Road Map

This section explains how to use the menu selection system. The **MENU** key on the operator panel allows you to use the menu to set or change the printer environment such as the number of copies to make, emulation, etc., to your specific needs. Settings can be made when Ready is indicated on the printer message display.



Note

**The printer obeys the most recently received printer settings sent from the application software, or from the printer driver, which take priority over operator panel settings.**

The following is the hierarchy diagram of the menu selection system of the printer.

The vertical transition is made with the ^ and v keys and horizontal transition is made with the > and < keys. To change or finalize configuration on an item, use the **ENTER** key.

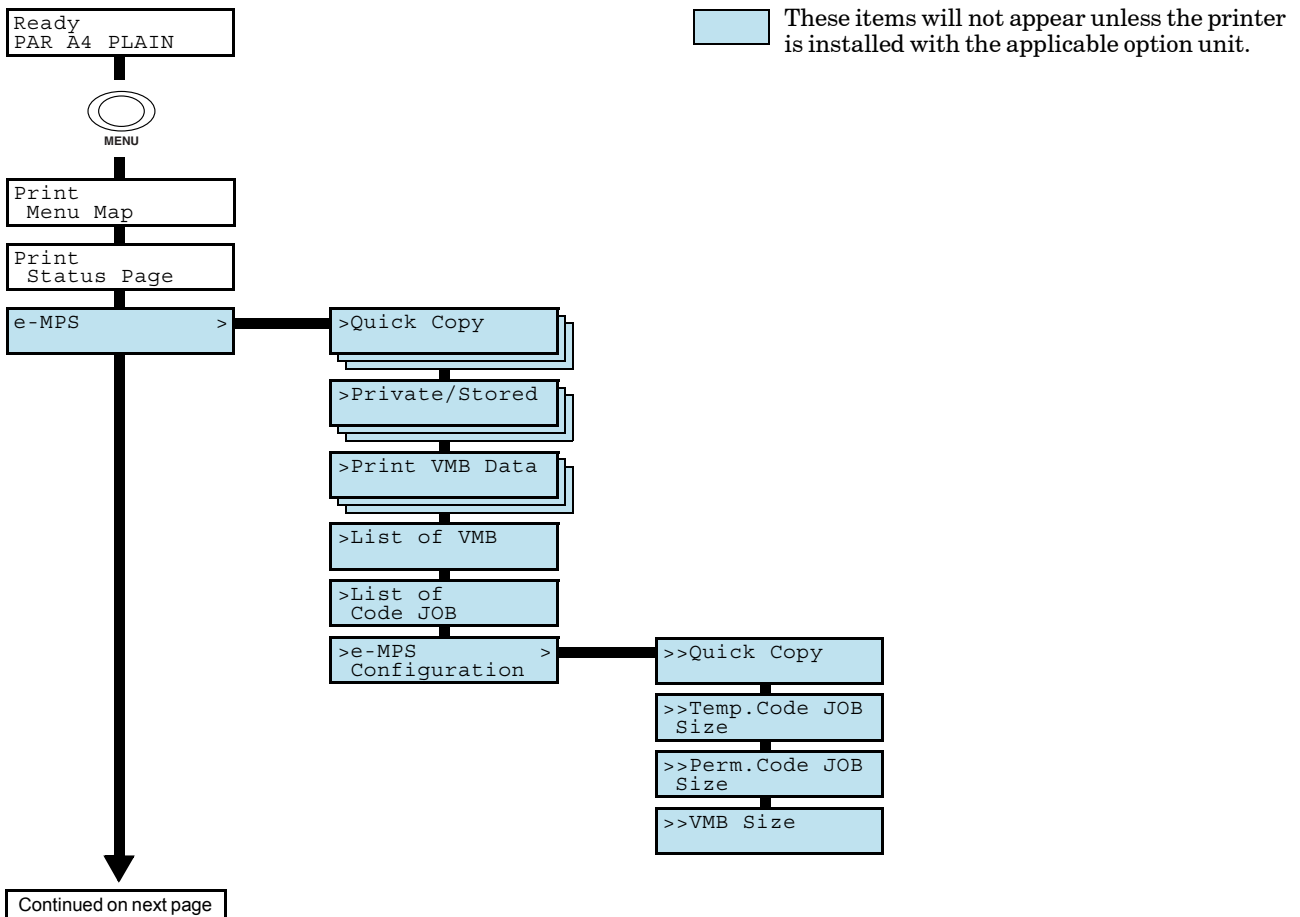

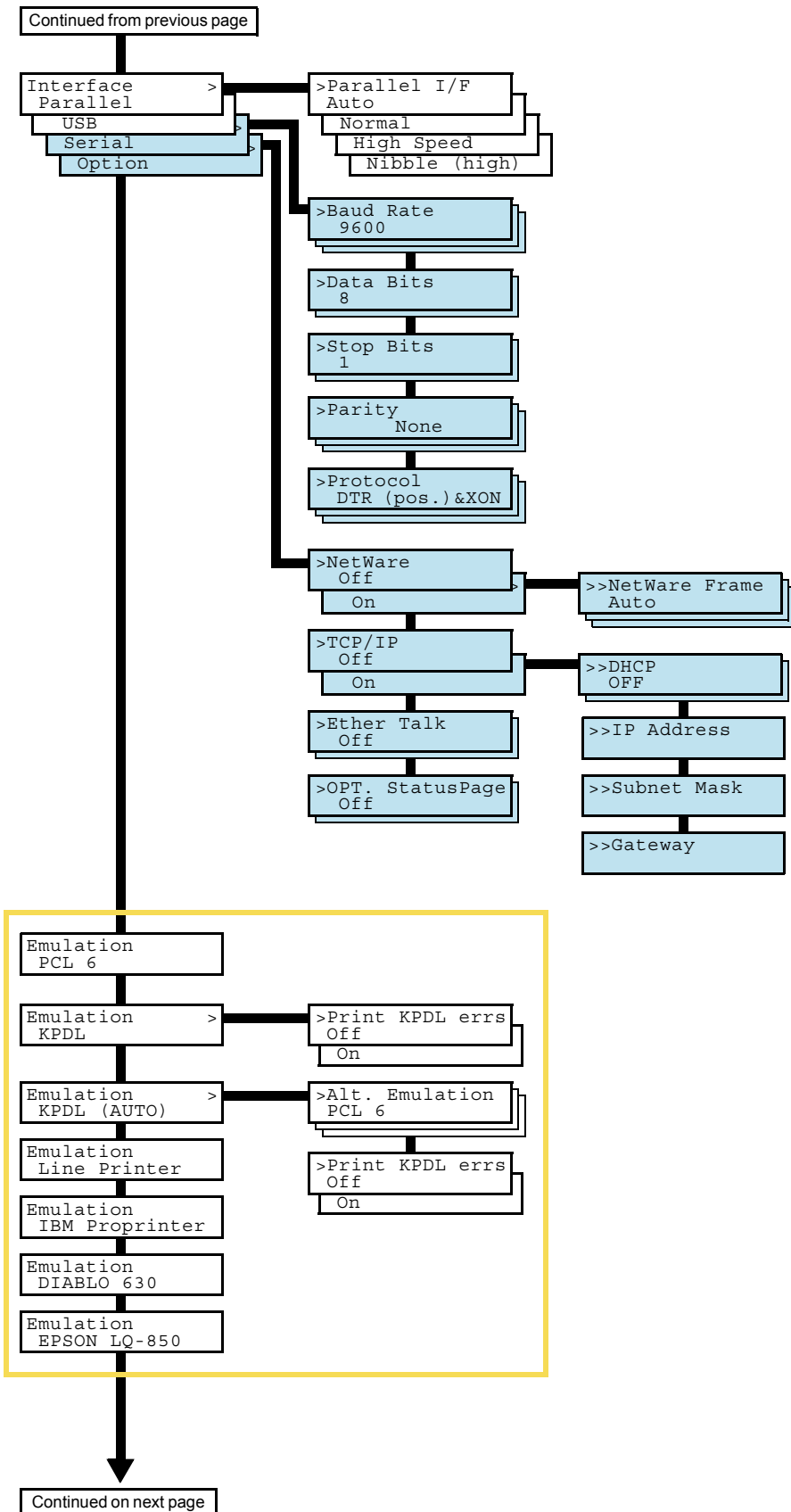

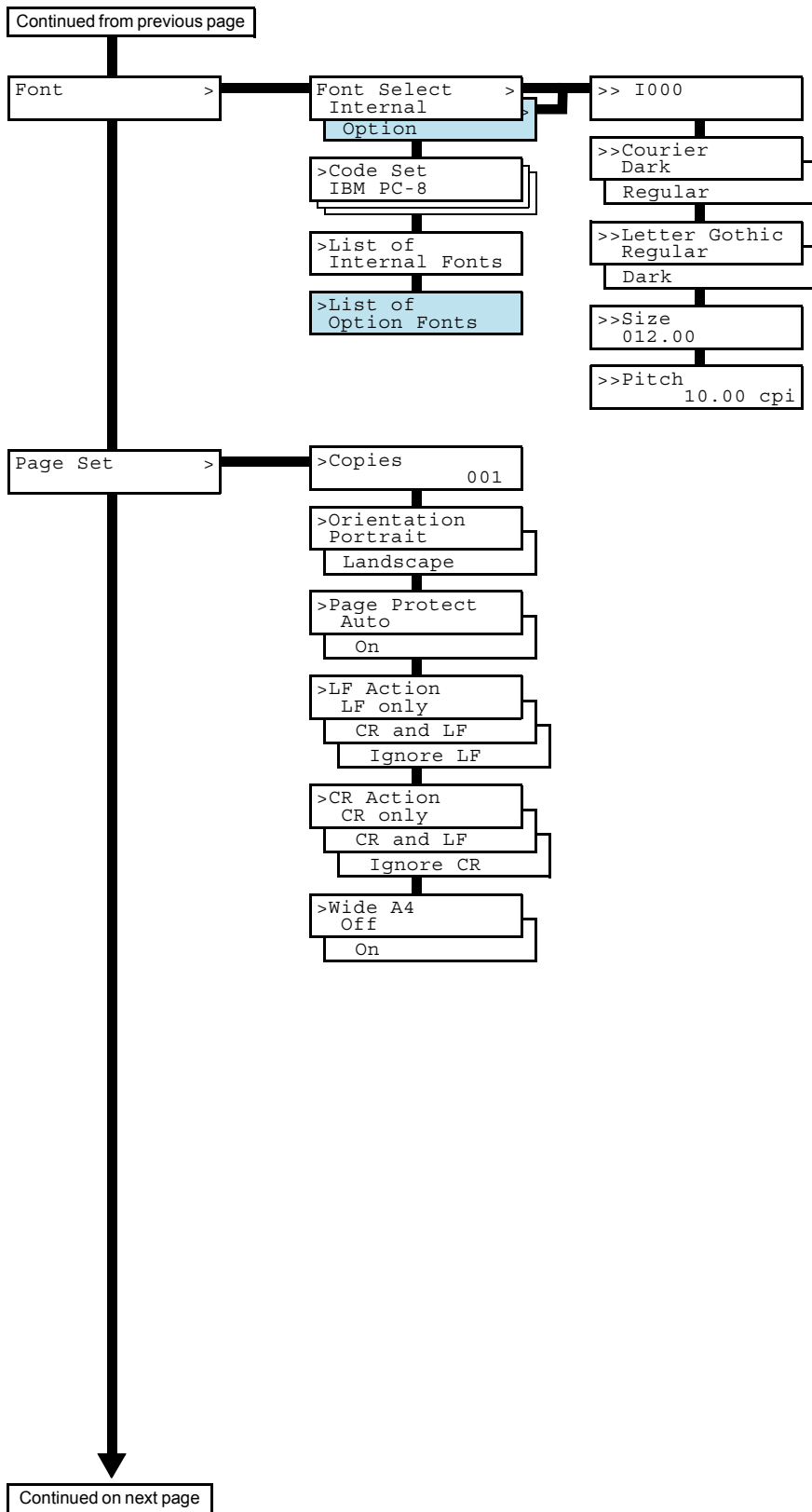

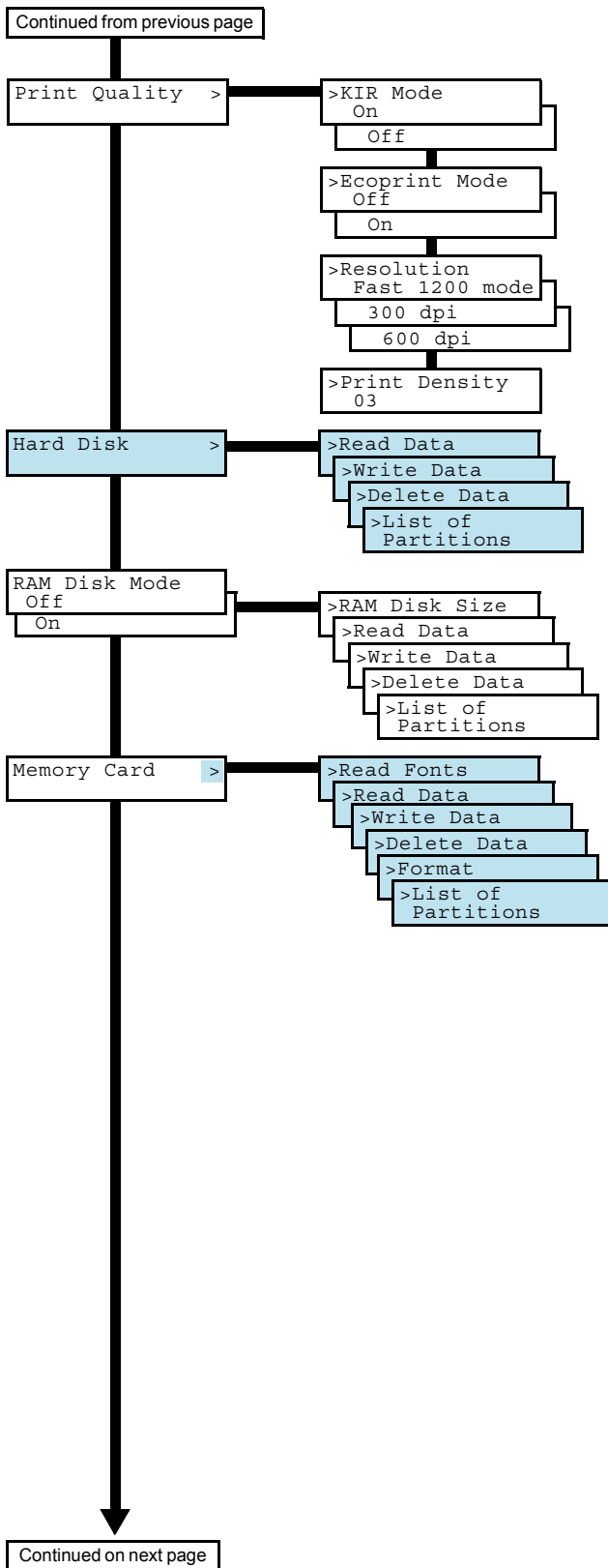

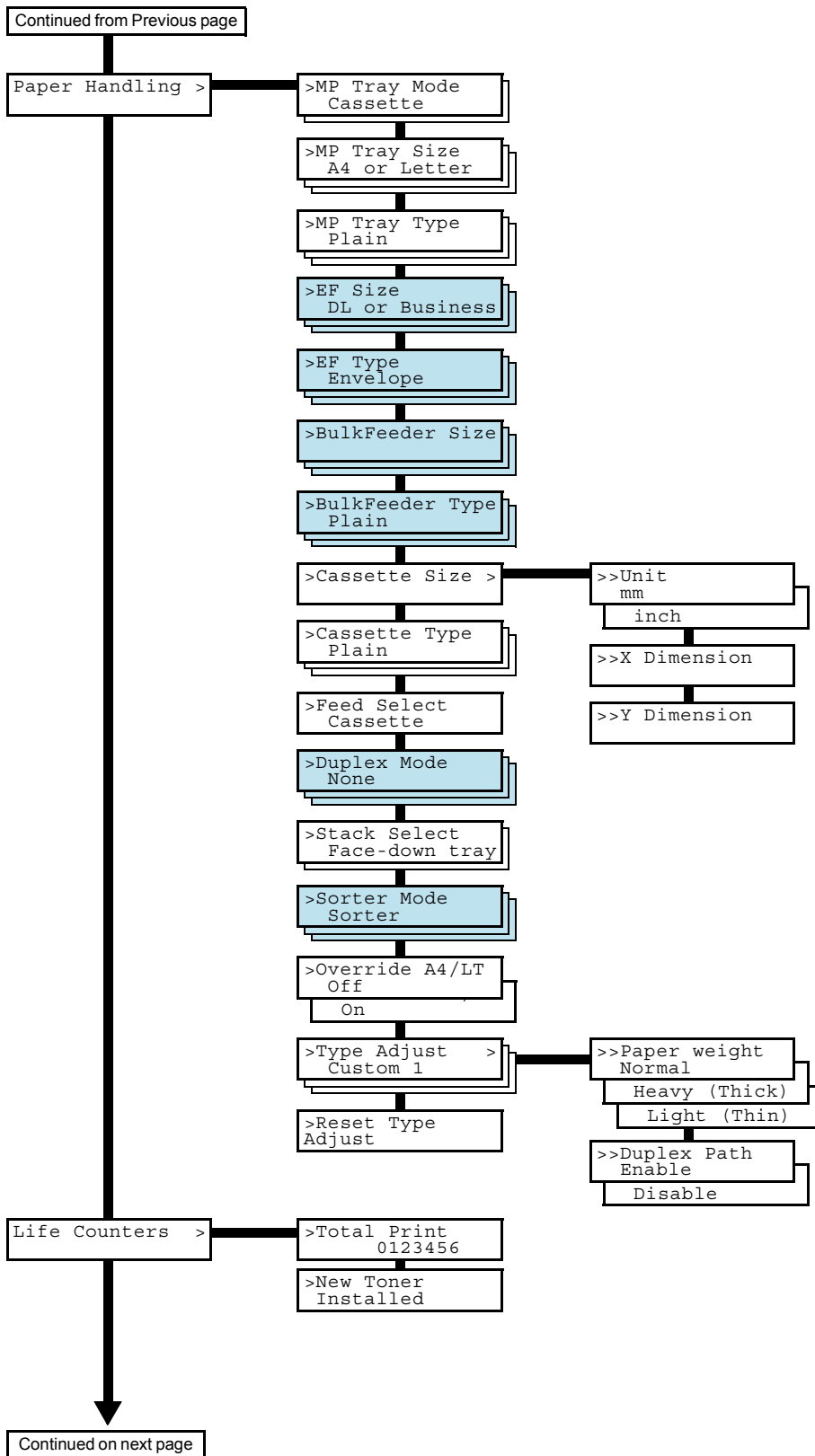



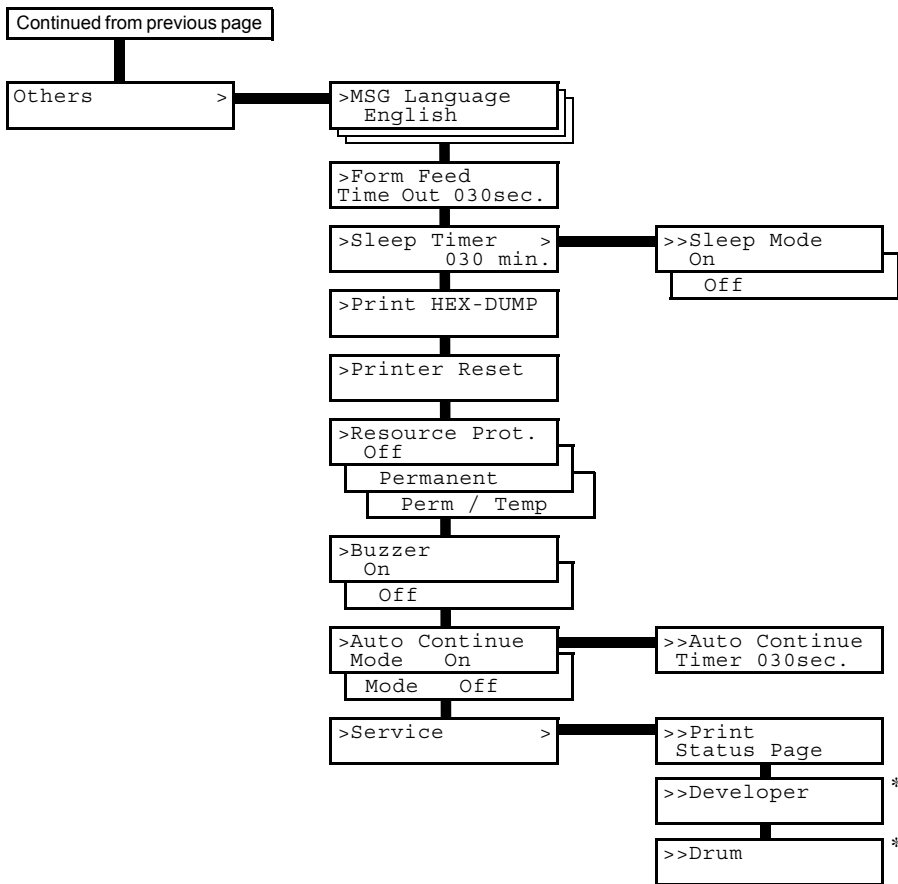

\* Since this menu is provided for service, normally you need not use it.

## Printing Test Pages

This section explains the procedure for printing the printer's internal information using the menu selection system. The menu map is useful as a reference to guide yourself through the menu selection system.

The status page is a list of parameters and settings for most basic printer configurations. You may be required to produce a status page when requesting service to the printer.

### Menu Map

The printer prints a full list of menu selection system. Note that menus indicated on the list may vary depending on which option units are installed on the printer.

- 1** Press the **MENU** key.
- 2** Press the **^** or **v** key repeatedly until `Print Menu Map` appears.

```
Print
Menu Map
```

- 3** Press the **ENTER** key. A question mark (?) appears.

```
Print
Menu Map ?
```

- 4** Press the **ENTER** key again. The printer prints a menu map.

Sample MENU MAP

**KYOCERA**  
*mita*

**Ecosys**® FS-1900 Page Printer

## MENU MAP

The menu map is structured as follows:

- Column 1 (18 items):** A vertical list of menu items, each with a header and a list of sub-items. The 1st, 3rd, 5th, 7th, 9th, 11th, 13th, 15th, and 17th items are highlighted with a grey background.
- Column 2 (18 items):** A vertical list of menu items, each with a header and a list of sub-items. The 1st, 3rd, 5th, 7th, 9th, 11th, 13th, 15th, and 17th items are highlighted with a grey background.
- Column 3 (10 items):** A vertical list of menu items, each with a header and a list of sub-items. The 1st, 3rd, 5th, 7th, and 9th items are highlighted with a grey background.

## Status Page

If you want to check the printer's current status, including memory available and option settings, you can find the information you need on the status page.

- 1** Press the **MENU** key.
- 2** Press the **^** or **v** key repeatedly until `Print Status Page` appears.

```
Print
Status Page
```

- 3** Press the **ENTER** key. A question mark (?) appears.

```
Print
Status Page ?
```

- 4** Press the **ENTER** key again. The printer prints a status page.

For a full description of the status page, see the following pages.

The following is a sample status page. The numbers below refer to the contents explained on the following pages.

**KYOCERA mita Ecosys FS-1900 Page Printer**

**STATUS PAGE**

Firmware Version: \_\_\_\_\_ Released: \_\_\_\_\_

**Hardware Information**

.....  
.....  
.....  
.....  
.....

**Memory**

.....  
.....  
.....  
.....  
.....

**Page Information**

.....  
.....  
.....

**Installed Options**

.....  
.....  
.....

**Network Status**

.....  
.....  
.....

**Emulation**

.....  
.....  
.....  
.....

**Error Log**

.....

**Toner Gauge**

0 \_\_\_\_\_ 100

**Interfaces**

.....  
.....  
.....  
.....  
.....  
.....

**KIR Test pattern**  ON



Items and values on the status page may vary depending on the printer's firmware version.

Note

### **1 — Software Version**

This information shows the firmware version and date of issue of the printer.

### **2 — Hardware Information**

This information shows various printer settings, such as the size and type of the paper in the paper cassettes.

### **3 — Memory**

This shows the amount of total memory installed in the printer, the amount of currently available memory, and the current status of the RAM disk. See *Operating the Storage Device* on page **1-81**.

### **4 — Page Information**

This shows the print resolution, number of copies, and the total page count.

### **5 — Installation Options**

This shows the option(s) installed in the printer.

### **6 — Network Status**

This shows the IP address, Subnet Mask address, and Default Gateway address for the network interface card installed in the printer.

### **7 — Emulation**

This shows all available emulations of the printer. The printer is shipped from the factory with PCL 6 emulation selected as the default.

### **8 — Error Log**

This shows the last three instances of the following four types of errors, listing them in the order of their occurrence: KPDL Error Press GO; Memory overflow Press GO; Print overrun Press GO; File not found Press GO. The most recent error is displayed on the top line of the Error Log. For error remedies, see section *Error Messages* on page **4-10**. Error information is cleared when the printer's power is turned off.

### **9 — Toner Gauge**

This shows the approximate level of remaining toner. When the value is 100, the toner container is full.

## **10 — Interface Information**

This information shows the default font and the default emulation for all interfaces installed in the printer.

## **11 — KIR Test Pattern**

KIR is the Kyocera Mita's original smoothing function. This test pattern shows the effect of the KIR (Kyocera Image Refinement) system.

## Service Status Page

The service status page contains printer settings information that is more detailed than the standard status page and is therefore for mostly service purposes. However, since there is a great deal of information available on the service status page that may be helpful to you, the procedure for printing it out is given below.

- 1** Press the **MENU** key.
- 2** Press the **^** or **∨** key repeatedly until `Others >` appears.

```
Others >
```

- 3** Press the **>** key.
- 4** Press the **^** or **∨** key repeatedly until `>Service >` appears.

```
>Service >
```

- 5** Press the **>** key.
- 6** Press the **^** or **∨** key repeatedly until `>>Print Status Page` appears.

```
>>Print  
Status Page
```

- 7** Press the **ENTER** key. A question mark (?) appears.

```
>>Print  
Status Page ?
```

- 8** Press the **ENTER** key again. The printer prints a service status page.



## Network Card Interface Status Page



To use this function, the network interface card must be installed on the printer.

You can print out a status page for the network interface. The network interface card status page shows the firmware version, the network addresses, and other information under various network protocols about the network interface card. The default setting is On (print). If the setting is changed to Off (not print) as follows, however, the network interface status page will be printed when the printer status page is printed.



Printing out a network interface card status page may not be possible with some network interface cards. For details, see the manual for the network interface card.

- 1 Press the **MENU** key.
- 2 Press the **^** or **∨** key repeatedly until `Interface >` appears.

```
Interface >
Parallel
```

- 3 Press the **ENTER** key. A blinking question mark (?) appears.

```
Interface
? Parallel
```

If you want to abandon the interface selection procedure, press the **CANCEL** key. The interface remains unchanged.

- 4 Press the **^** or **∨** key repeatedly until `Option` appears.

```
Interface
? Option
```

- 5 Press the **ENTER** key again. A `>` appears.

```
Interface >
Option
```

- 6 Press the **>** key and then press the **^** or **∨** key repeatedly until the message display indicates `>Opt. StatusPage`.

```
>Opt. StatusPage
On
```

- 7** The default setting is On. If it is set to Off, change it as follows. Press the **ENTER** key. A blinking question mark (?) appears.

```
>Opt. StatusPage
? Off
```

- 8** Select On using the ^ or v key.

```
>Opt. StatusPage
? On
```

- 9** Press the **ENTER** key again.

```
>Opt. StatusPage
  On
```

- 10** Press the **MENU** key. The message display returns to Ready.

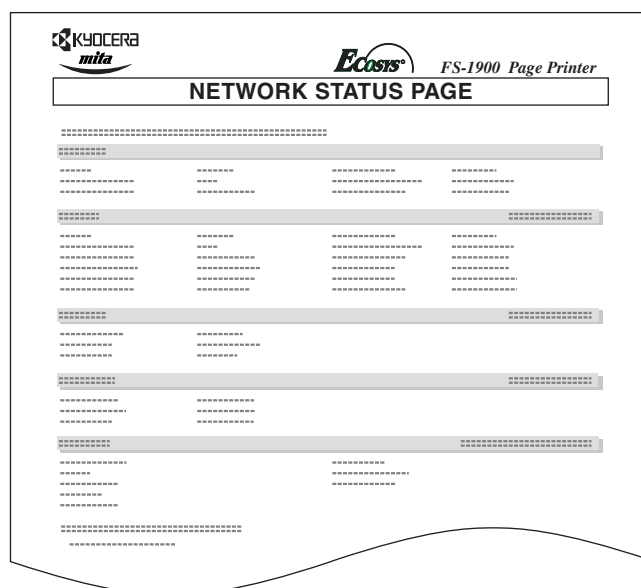

## Font Lists

To help in selecting fonts, you can print the lists of the fonts including option fonts.

**1** Press the **MENU** key.

**2** Press the  $\wedge$  or  $\vee$  key repeatedly until `Font >` appears.

```
Font >
```

**3** Press the `>` key.

**4** Press the  $\wedge$  or  $\vee$  key repeatedly until `>Font Select>` appears.

```
>Font Select >
Internal
```

**5** To print a list of the internal fonts, check that `Internal` is displayed. To print a list of option fonts, press the **ENTER** key. Press the  $\wedge$  or  $\vee$  key repeatedly until the message display indicates `Option` and press the **ENTER** key.

**6** Press the  $\wedge$  or  $\vee$  key repeatedly until `>List of Internal Fonts` or `>List of Option Fonts` appears.

```
>List of
Internal Fonts
```

**7** Press the **ENTER** key. A question mark (?) appears.

```
>List of
Internal Fonts?
```

**8** Press the **ENTER** key again. Processing appears, then `Ready`. The printer prints a list of fonts with a short sample and font ID (number) for each font.



## Received Data Dumping

It is possible to print data received by the printer as hexadecimal code for the purposes of debugging programs and files.

- 1 Press the **MENU** key.
- 2 Press the **^** or **∨** key repeatedly until `Others >` appears.

```
Others >
```

- 3 Press the **>** key.
- 4 Press the **^** or **∨** key repeatedly until `>Print HEX-DUMP` appears.

```
>Print HEX-DUMP
```

- 5 Press the **ENTER** key. A question mark (?) appears.

```
>Print HEX-DUMP?
```

- 6 Press the **ENTER** key again. `Processing` appears for a second, and then `Waiting` appears.

```
Processing
```



```
Waiting
```

- 7 Send data to be dumped to the printer. The message `Processing` will be displayed during receiving the data.

Once the dumped data you require has been output, it is possible to cancel the printing of any further dumped data by taking the printer offline by pressing the **GO** key and then pressing the **CANCEL** key.

- 8 Once all data has been received, the message `Waiting` will appear. Press the **GO** key to finish printing.

## Paper Handling

This section explains how to use the operator panel to change the paper size and type for each paper source, the mode for the MP (multi-purpose) tray, and other settings regarding paper handling.

### Setting the Paper Size

Set the paper sizes according to the sizes of paper to be set in the paper cassette and the MP tray.

If they do not match, printing will not be made on the correct size paper when automatic paper size selection is made by the application software (printer driver).

#### Setting the Paper Size in Paper Cassette

To set the standard sizes A5, A4, B5, Letter, and Legal (for U. S. A. only) size for the paper cassette, use the following procedure to set the paper size dial of the paper cassette.

If you use a non-standard size, see [Custom Paper Size](#) on next page.

Properly set the paper into the paper cassette. For details about the adjustment of the paper guides and paper stopper inside the paper cassette, set the [Installation Guide](#) supplies with the printer.

- 1 Turn the paper size dial so that the size of the paper you are going to use appears in the paper size window.

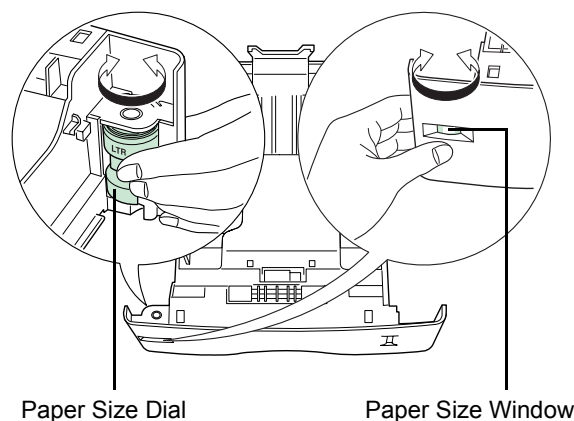

- 2 Adjust the paper guides and paper stopper inside the paper cassette to the size of the paper to be used and load the paper into the cassette.

The paper size setting for the paper cassette is completed.

## Custom Paper Size

In addition to the standard sizes A5, A4, B5, Letter, and Legal (for U. S. A. only) size for the paper cassette, paper of other sizes can be fed as custom sizes. When placing paper of sizes other than A5, A4, B5, Letter, or Legal (for U. S. A. only) into the paper cassette, set the size of the paper to be used into the printer by following the procedure given below. If an option paper feeder (PF-60) is installed, custom sizes for its paper cassette can be set using the same procedure.

This menu appears when the paper size dial of the paper cassette is set to **CUSTOM**.

Properly set the paper into the paper cassette. For details about the adjustment of the paper guides and paper stopper inside the paper cassette, see the *Installation Guide* supplied with the printer.

## Setting Paper Size Dial

Use the following procedure to set the paper size dial to **CUSTOM**.

- 1** Pull out the paper cassette from the printer and turn the paper size dial to **CUSTOM**. See *step 1* in *Setting the Paper Size in Paper Cassette*.
- 2** Adjust the paper guides and paper stopper inside the paper cassette to the size of the paper to be used and load the paper into the cassette.

When using non-standard size paper, read the next section to set the paper size from the operator panel.

## Setting a custom size from the Operator Panel

Set the size of the paper loaded in the paper cassette into the printer from the printer operator panel.

- 1** Press the **MENU** key.
- 2** Press the  $\wedge$  or  $\vee$  key repeatedly until `Paper Handling >` appears.

`Paper Handling >`

- 3** Press the **>** key.

- 4 Press the  $\wedge$  or  $\vee$  key repeatedly until `>Cassette Size >` appears.

If option paper feeders are added, `Cassette 1 Size` will appear for the standard paper cassette and `Cassette 2 Size`, `Cassette 3 Size`, and `Cassette 4 Size` will appear for the option paper feeders.

```
>Cassette Size >
```

Set the unit of measurement as described in the next section.

### Selecting the Unit of Measurement

Then, use the following procedure to set the unit of measurement.

- 1 Press the `>` key.
- 2 Press the  $\wedge$  or  $\vee$  key repeatedly until `>>Unit` appears. The unit of measurement can be selected between millimeters and inches. The current unit of measurement is displayed (the default setting is mm).

```
>>Unit  
mm
```

- 3 Press the **ENTER** key. A blinking question mark (?) appears.

```
>>Unit  
? mm
```

- 4 Select mm or inch using the  $\wedge$  or  $\vee$  key.
- 5 Press the **ENTER** key.

Set the dimensions of paper as described in the next section.



### Entering the Width and Length

Then, use the following procedure to set the paper size.

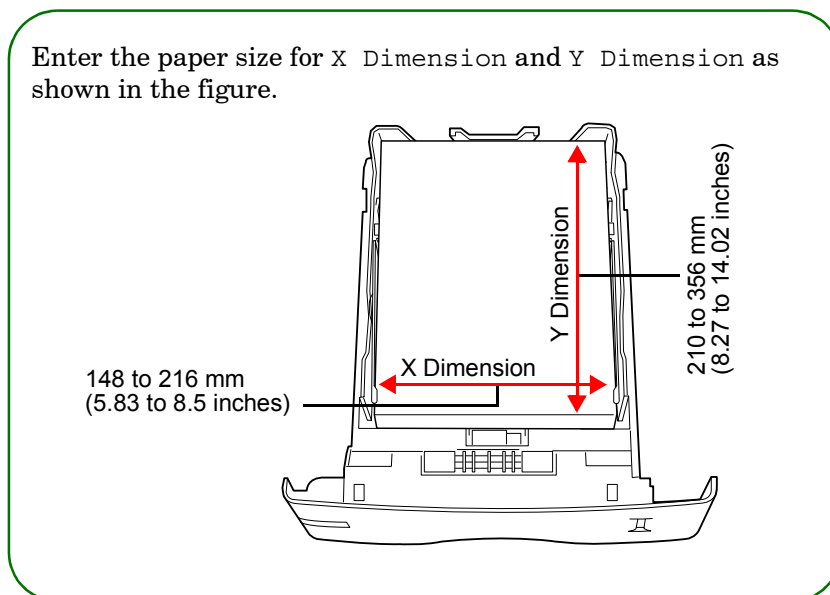

- 1 When the unit of measurement is set, press the  $\vee$  key.  $\gg$ X Dimension appears as shown below (the paper width setting).

```
>>X Dimension
      216 mm
```

- 2 Press the **ENTER** key. A blinking cursor (  $\_$  ) appears.

```
>>X Dimension
      216 mm
          ^
```

- 3 Press the  $\wedge$  or  $\vee$  key to increase or decrease the value of the figure where the cursor is blinking and display the desired width. The width can be set between 148 and 216 mm (5.83 to 8.5 inches). You can use the  $\gg$  and  $\ll$  keys to move the cursor right and left.
- 4 Display the paper width and press the **ENTER** key.
- 5 When the width is set, press the  $\vee$  key.  $\gg$ Y Dimension appears (the paper length setting). Set the desired length in the same way as the width. The length can be set between 210 and 356 mm (8.27 to 14.02 inches).
- 6 Display the paper length, press the **ENTER** key.

- 7 Press the **MENU** key. The message display returns to Ready.

To print using the custom size set above, define the same custom size on the printer driver. For details, see [Setting Custom Paper Size in Printer Driver Guide](#).

### Setting the Paper Size in MP Tray

When using the MP tray in the cassette mode, you should set the same paper size to the MP tray as that is used to format the job to print. The factory default setting is A4 or Letter.

This menu does not appear when the option envelope feeder is installed on the printer.

For more details about the paper sizes that can be fed from the MP tray, see [Chapter 2](#).

- 1 Press the **MENU** key.
- 2 Press the  $\wedge$  or  $\vee$  key repeatedly until Paper Handling > appears.

```
Paper Handling >
```

- 3 Press the > key.
- 4 Press the  $\wedge$  or  $\vee$  key repeatedly until >MP Tray Size appears.

```
>MP Tray Size  
A4
```

- 5 Press the **ENTER** key. A blinking question mark (?) appears.

```
>MP Tray Size  
? A4
```

- 6** Press the  $\wedge$  or  $\vee$  key to display the desired MP tray size. The display changes as shown below.

A4  
Executive  
Letter  
Legal  
Custom  
Oficio II  
Statement  
Folio  
Youkei 2  
Youkei 4  
Hagaki  
OufukuHagaki  
Monarch  
Business  
Comm. #9  
Comm. #6 3/4  
DL  
C5  
A6  
B6  
A5  
B5  
ISO B5

- 7** When the desired paper size is displayed, press the **ENTER** key.

- 8** Press the **MENU** key. The message display returns to Ready.

The paper size setting for the MP tray is completed.

## Setting the Paper Type

Set the paper types according to the paper to be set in the cassette and the MP tray.

### Setting the Paper Type in Paper Cassette

Make this setting to match the paper type fed from the paper cassette of the printer. If the paper type is set correctly, you can perform printing using the media type selection function from the application software (printer driver). The factory default setting is `Plain`.

For more details about the paper types that can be fed from the paper cassette, see [Chapter 2](#).

- 1 Press the **MENU** key.
- 2 Press the  $\wedge$  or  $\vee$  key repeatedly until `Paper Handling >` appears.

```
Paper Handling >
```

- 3 Press the  $>$  key.
- 4 Press the  $\wedge$  or  $\vee$  key repeatedly until `>Cassette Type` appears.

```
>Cassette Type  
Plain
```

- 5 Press the **ENTER** key. A blinking question mark (?) appears.

```
>Cassette Type  
? Plain
```

- 6 Press the  $\wedge$  or  $\vee$  key to display the desired cassette type. The display changes as shown below.

```
Plain  
Preprinted  
Bond  
Recycled  
Rough  
Letterhead  
Color  
Prepunched  
Custom (1 to 8)
```

- 7 When the desired cassette type is displayed, press the **ENTER** key.
- 8 Press the **MENU** key. The message display returns to `Ready`.

## Setting the Paper Type in MP Tray

You can automatically select the paper cassette according to the selection made by the application software (printer driver). The factory default setting is Plain.

This menu does not appear when the option envelope feeder is installed on the printer.

For more details about the paper types that can be fed from the MP tray, see [Chapter 2](#).

- 1 Press the **MENU** key.
- 2 Press the **^** or **v** key repeatedly until Paper Handling > appears.

```
Paper Handling >
```

- 3 Press the **>** key.
- 4 Press the **^** or **v** key repeatedly until >MP Tray Type appears.

```
>MP Tray Type  
Plain
```

- 5 Press the **ENTER** key. A blinking question mark (?) appears.

```
>MP Tray Type  
? Plain
```

- 6 Press the ^ or v key to display the desired MP tray type. The display changes as shown below.

```
Plain
Transparency
Preprinted
Labels
Bond
Recycled
Vellum
Rough
Letterhead
Color
Prepunched
Envelope
Cardstock
Custom (1 to 8)
```

- 7 When the desired MP tray type is displayed, press the **ENTER** key.

- 8 Press the **MENU** key and the message display returns to Ready.

## Custom Paper Type

The following describes the procedure used to set a user-defined paper type for the printer. Eight custom user settings may be registered. After having been set, any of these may be called up when setting the paper type for a paper source.

The paper weight and duplex path can be set (see [Setting the Paper Weight](#) on page 1-34, and [Setting the Duplex Path](#) on page 1-35) after selecting the paper type to be customized as follows. For how to reset the customized settings, see [Resetting the Custom Paper Type](#) on page 1-36.

- 1 Press the **MENU** key.
- 2 Press the ^ or v key repeatedly until Paper Handling > appears.

```
Paper Handling >
```

- 3 Press the > key.
- 4 Press the ^ or v key repeatedly until >Type Adjust > appears.

```
>Type Adjust >
Custom 1
```

- 5** Press the **ENTER** key. A blinking question mark (?) appears.

```
>Type Adjust  >  
? Custom 1
```

- 6** Press the ^ or v key to display the desired paper type. The display changes as shown below.

```
Custom (1 to 8)  
Plain  
Transparency  
Preprinted  
Labels  
Bond  
Recycled  
Vellum  
Rough  
Letterhead  
Color  
Prepunched  
Envelope  
Cardstock
```

- 7** When the paper type to be customized is displayed, press the **ENTER** key.
- 8** Press the > key and proceed to *Setting the Paper Weight* on the following page.

Proceed to *Setting the Paper Weight* and *Setting the Duplex Path* starting from the following page.

### Setting the Paper Weight

You can set the paper thickness for your custom paper type to be customized.

**1** Display the custom paper type (see *Custom Paper Type* on page [1-32](#)) and press the > key.

**2** Press the ^ or v key repeatedly until >>Paper Weight appears.

```
>>Paper Weight
Normal
```

**3** Press the **ENTER** key. A blinking question mark (?) appears.

```
>>Paper Weight
? Normal
```

**4** Press the ^ or v key to display the desired paper thickness. The display changes as shown below. For details of the default setting for each paper type, see *Paper Type* on page [2-11](#).

```
Normal
Heavy (Thick)
Light (Thin)
```

**5** When the desired paper thickness displayed, press the **ENTER** key.

**6** Press the **MENU** key. The message display returns to Ready.

If the paper type is set to `Custom` and the option `duplexer` is installed on the printer, duplex printing can be enabled and disabled. See *Setting the Duplex Path* on the following page.



## Setting the Duplex Path



To use this function, the duplexer must be installed on the printer.

If the paper type is set to Custom and the option duplexer is installed on the printer, you can set whether or not to enable duplex printing as follows. The default setting is Enable.

- 1 Display the custom paper type (see *Custom Paper Type* on page [1-32](#)) and press the > key.
- 2 Press the ^ or v key repeatedly until >>Duplex path appears.
 

```
>>Duplex path
  Enable
```
- 3 Press the **ENTER** key. A blinking question mark (?) appears.
 

```
>>Duplex path
? Enable
```
- 4 Select Enable or Disable using the ^ or v key. For details of the default setting for each paper type, see *Paper Type* on page [2-11](#).
- 5 Press the **ENTER** key.
- 6 Press the **MENU** key. The message display returns to Ready.

The custom paper type setting is completed.

### Resetting the Custom Paper Type

Resets the settings of Custom 1 to 8 that are set in *Custom Paper Type* on page [1-32](#).

- 1** Press the **MENU** key.
- 2** Press the **^** or **v** key repeatedly until Paper handling > appears.

```
Paper Handling >
```

- 3** Press the **>** key.
- 4** Press the **^** or **v** key repeatedly until >Reset Type Adjust appears.

```
>Reset Type  
Adjust
```

- 5** Press the **ENTER** key. A question mark (?) appears.

```
>Reset Type  
Adjust ?
```

- 6** Press the **ENTER** key. All the customized paper weight and duplex path settings will be reset to the default. The message display returns to Ready.

## MP Tray Mode

The MP tray can be used in either of two modes – first or cassette. The MP tray feed paper differently depending on the mode:

- **Cassette Mode**  
This is the default mode. The MP tray acts in the same manner as other paper source. The printer can correctly feed paper from any paper source as you command on the printer driver. The cassette mode provides a faster printing speed than the first mode.
- **First Mode**  
The MP tray automatically feeds paper placed on the MP tray overriding another paper source that is selected on the printer driver. After all paper sheets in the MP tray have been used up (approximately 100 sheets [A4 size, 0.11 mm thickness]), paper will be fed from the paper source originally selected. This mode is convenient to feed paper of special size or type without reloading the current paper source. However, the MP tray must be kept empty if you desire to feed paper from the intended paper source.

This menu does not appear when the option envelope feeder is installed on the printer.



Note

**The maximum capacity for the MP tray of 100 sheets is based on A4 paper. If you use Legal size paper on the MP tray, the number of paper you use should be considerably smaller than 100 sheets to avoid possible paper jam.**

To switch the MP tray to First mode, proceed as follows:

- 1** Press the **MENU** key.
- 2** Press the **^** or **∨** key repeatedly until **Paper Handling >** appears.

```
Paper Handling >
```

- 3** Press the **>** key.
- 4** Press the **^** or **∨** key repeatedly until **>MP Tray Mode** appears.

```
>MP Tray Mode  
Cassette
```

- 5** Press the **ENTER** key. A blinking question mark (?) appears.

```
>MP Tray Mode
? Cassette
```

- 6** Select `First` or `Cassette` using the `^` or `v` key.
- 7** Press the **ENTER** key.
- 8** Press the **MENU** key. The message display returns to `Ready`.

## Selecting the Paper Feed Source

You can select from which paper source printing will be performed. If no option units are installed, the only selections are the paper cassette and MP tray of the printer. If option paper feeders are installed, they can also be selected using the manner described below.

- 1** Press the **MENU** key.
- 2** Press the `^` or `v` key repeatedly until `Paper Handling >` appears.

```
Paper Handling >
```

- 3** Press the `>` key.
- 4** Press the `^` or `v` key repeatedly until `>Feed Select` appears.

```
>Feed Select
Cassette
```

- 5** Press the **ENTER** key. A blinking question mark (?) appears.

```
>Feed Select
? Cassette
```

- 6** Select `MP tray` or `Cassette` using the `^` or `v` key.
- 7** Press the **ENTER** key.
- 8** Press the **MENU** key. The message display returns to `Ready`.

## Output Stack

The following procedure allows you to select whether printouts will be received by the face-down output tray or to the face-up output tray. If an option sorter is installed, it can also be selected using the manner described below.

- 1 Press the **MENU** key.
- 2 Press the  $\wedge$  or  $\vee$  key repeatedly until Paper Handling > appears.

```
Paper Handling >
```

- 3 Press the > key.
- 4 Press the  $\wedge$  or  $\vee$  key repeatedly until >Stack Select appears.

```
>Stack Select  
Face-down tray
```

- 5 Press the **ENTER** key. A blinking question mark (?) appears.

```
>Stack Select  
? Face-down tray
```

- 6 Press the  $\wedge$  or  $\vee$  key to display the desired destination. The output tray changes as shown below.

```
Face-down tray (Printer's face-down output tray) [Default]  
Face-up tray (Printer's face-up output tray) [Option face-up  
tray required]
```

- 7 When the desired paper source displayed, press the **ENTER** key.
- 8 Press the **MENU** key. The message display returns to Ready.

## Overriding A4 and Letter Size Difference

This selects whether to enable or disable the difference between A4 size and Letter size. Under the default setting of `Off`, the paper size of the paper source is matched to the paper size formatting the jobs. If these differ, a corresponding error message is displayed. When this is set to `On`, printing is performed even if the actual paper size differs from the paper size formatting the jobs.

- 1 Press the **MENU** key.
- 2 Press the  $\wedge$  or  $\vee$  key repeatedly until `Paper Handling >` appears.

```
Paper Handling >
```

- 3 Press the `>` key.
- 4 Press the  $\wedge$  or  $\vee$  key repeatedly until `>Override A4/LT` appears.

```
>Override A4/LT  
Off
```

- 5 Press the **ENTER** key. A blinking question mark (?) appears.

```
>Override A4/LT  
? Off
```

- 6 Select `On` or `Off` using the  $\wedge$  or  $\vee$  key.
- 7 Press the **ENTER** key.
- 8 Press the **MENU** key. The message display returns to `Ready`.

## Pagination

The items regarding pagination can be made from the operator panel. The items that can be set are shown below.

- Emulation
- Font
- Code Set
- Number of Copies
- Printing Orientation
- KIR (Kyocera Image Refinement)
- Ecoprint
- Resolution

## Emulation

The following procedure allows you to select the printer's emulation mode.

### Changing the Emulation

To change the emulation mode, proceed as follows:

- 1** Press the **MENU** key.
- 2** Press the **^** or **∨** key repeatedly until **Emulation** appears. One of the emulation modes shown below appears, indicating the current emulation.

```
PCL 6 (default)
KPD L
KPD L (AUTO)
Line Printer
IBM Proprinter
DIABLO 630
EPSON LQ-850
```

KPD L is the Kyocera's implementation of the PostScript page description language.

- 3** Press the **ENTER** key. A blinking question mark (?) appears.

```
Emulation
?PCL 6
```

- 4** Press the **^** or **∨** key repeatedly until the desired emulation mode appears.

- 5 Press the **ENTER** key.
- 6 Press the **MENU** key. The message display returns to Ready.

### Alternative Emulation for KPD L Emulation

The auto KPD L (KPD L (AUTO)) emulation enables the printer to automatically change the emulation mode according to the print job received. The alternative emulation can be selected using the operator panel. The default alternative emulation is PCL 6.

- 1 Press the **MENU** key.
- 2 Press the ^ or v key repeatedly until Emulation appears.

```
Emulation
PCL 6
```

- 3 Press the **ENTER** key. A blinking question mark (?) appears.

```
Emulation
?PCL 6
```

- 4 Press the ^ or v key repeatedly until the message display indicated KPD L (AUTO) appears.

```
Emulation
?KPD L (AUTO)
```

- 5 Press the **ENTER** key.
- 6 Press the > key. When > Print KPD L Errs is displayed, press the ^ or v key. The display cycles through the emulation in the following order:

```
PCL 6 (default)
Line Printer
IBM Proprinter
DIABLO 630
EPSON LQ-850
```

- 7 Press the **ENTER** key. A blinking question mark (?) appears.

```
>Alt. Emulation
?PCL 6
```



- 8 Press the  $\wedge$  or  $\vee$  key repeatedly until the desired alternative emulation appears.
- 9 Press the **ENTER** key.
- 10 Press the **MENU** key. The message display returns to Ready.

## Printing KPD L Errors

The printer can print error descriptions when printing error occurs during KPD L emulation. The default is `Off` – the printer does not print KPD L errors.

- 1 Press the **MENU** key.
- 2 Press the  $\wedge$  or  $\vee$  key repeatedly until `Emulation >` appears.

```
Emulation
PCL 6
```

- 3 Press the **ENTER** key. A blinking question mark (?) appears.

```
Emulation
?PCL 6
```

- 4 Select `KPD L` or `KPD L (AUTO)` using the  $\wedge$  or  $\vee$  key.

```
Emulation
?KPD L
```

- 5 Press the **ENTER** key.
- 6 Press the `>` key. The message display changes to that shown below. If `>Alt`. Emulation is displayed when the `KPD L (AUTO)` emulation is selected, press the  $\wedge$  or  $\vee$  key to change it.

```
>Print KPD L Errs
Off
```

- 7 Press the **ENTER** key. A blinking question mark (?) appears.

```
>Print KPD L Errs
? Off
```

- 8 Select On using the ^ or v key.

```
>Print KPDL Errs
? On
```

- 9 Press the **ENTER** key.
- 10 Press the **MENU** key. The message display returns to Ready.

## Font

You can select the default font for the current interface. In addition to the internal fonts, all fonts that are downloaded to the printer memory, or fonts stored on a CompactFlash card, Microdrive, or option ROM, can be selected as the default font.

In this menu, you can also set the type and pitch for Courier and Letter Gothic.

### Default font

- 1 Press the **MENU** key.
- 2 Press the ^ or v key repeatedly until Font > appears.

```
Font >
```

- 3 Press the > key.
- 4 Press the ^ or v key repeatedly until >Font Select > appears.

```
>Font Select >
  Internal
```

- 5 To select an internal font, check that Internal is displayed. If Internal is not displayed, press the **ENTER** key. Press the ^ or v key repeatedly until the message display indicates Internal and press the **ENTER** key.

To select an option font, press the **ENTER** key. Press the ^ or v key repeatedly until the message display indicates Option and press the **ENTER** key. This operation is possible only when option fonts are installed in the printer.

- 6** Press the > key. The message display changes to that show below.

```
>> I000
```

The letter before the number indicates the type of font as shown below:

Letter	Description
I	Internal font
S	Soft (down load) font
M	Fonts in an option CompactFlash card
H	Fonts in a RAM disk or option Microdrive.
O	Fonts in an option ROM

- 7** Press the **ENTER** key. A blinking question mark (?) appears.

```
>>?I000
```

- 8** Press the ^ or v key repeatedly until the desired font number appears. For font numbers of the internal fonts, see [List of Fonts](#) on page [A-2](#).

- 9** When the desired font is displayed, press the **ENTER** key.

- 10** Press the **MENU** key. The message display returns to Ready.

## Default Font Size

The following procedure determines the size of the default font. If the default font is a fixed font such as Courier or Letter Gothic, the character pitch can be changed instead of the font size.

- 1 Press the **MENU** key.
- 2 Press the **^** or **∨** key repeatedly until `Font >` appears.

```
Font >
```

- 3 Press the **>** key.
- 4 Press the **^** or **∨** key repeatedly until `>Font Select >` appears.

```
>Font Select >
Internal
```

- 5 Check that `Internal` is displayed and press the **>** key.
- 6 Press the **^** or **∨** key repeatedly until `>>Size` appears.

```
>>Size
012.00 point(s)
```

- 7 Press the **ENTER** key. A blinking cursor (`_`) appears.

```
>>Size
012.00_ point(s)
```

- 8 Press the **^** or **∨** key to increase or decrease the value of the figure where the cursor is blinking. The font size can be set between 4 and 999.75 points, in 0.25-point increments. You can use the **>** or **<** key to move the cursor right and left.
- 9 When the desired size is displayed, press the **ENTER** key.
- 10 Press the **MENU** key. The message display returns to `Ready`.

## Changing Type for Courier/Letter Gothic

Courier or Letter Gothic font type can be selected as Regular or Dark. For example, to change the type of Courier, proceed as follows:

**1** Press the **MENU** key.

**2** Press the  $\wedge$  or  $\vee$  key repeatedly until `Font >` appears.

```
Font >
```

**3** Press the `>` key.

**4** Press the  $\wedge$  or  $\vee$  key repeatedly until `>Font Select >` appears.

```
>Font Select >
Internal
```

**5** Check that `Internal` is displayed and press the `>` key.

**6** Press the  $\wedge$  or  $\vee$  key repeatedly until `>>Courier` appears.

```
>>Courier
Regular
```

**7** Press the **ENTER** key. A blinking question mark (?) appears.

```
>>Courier
? Regular
```

**8** Select `Regular` or `Dark` using the  $\wedge$  or  $\vee$  key.

**9** Press the **ENTER** key.

**10** Press the **MENU** key and the message display returns to `Ready`.

### Setting the Character Pitch for Courier/Letter Gothic

The character pitch for fixed fonts is adjustable when the default font is Courier or Letter Gothic.

**1** Press the **MENU** key.

**2** Press the **^** or **∨** key repeatedly until `Font >` appears.

```
Font >
```

**3** Press the **>** key.

**4** Press the **^** or **∨** key repeatedly until `>Font Select >` appears.

```
>Font Select >
Internal
```

**5** Check that `Internal` is displayed and press the **>** key.

**6** Press the **^** or **∨** key repeatedly until `>>Pitch` appears.

```
>>Pitch
10.00 cpi
```

**7** Press the **ENTER** key. A blinking cursor (`_`) appears.

```
>Pitch
10.00 cpi
```

**8** Press the **^** or **∨** key to increase or decrease the value of the figure where the cursor is blinking. The character pitch can be set between 0.44 and 99.99 characters per inch, in 0.01 character-per-inch increments. You can use the **>** or **<** keys to move the cursor right and left.

**9** When the desired size is displayed, press the **ENTER** key.

**10** Press the **MENU** key. The message display returns to `Ready`.

## Code Set

You can change the character code set. Available character code sets vary depending on the current font. (The default is IBM PC-8.)

- 1** Press the **MENU** key.
- 2** Press the **^** or **∨** key repeatedly until `Font >` appears.

```
Font >
```

- 3** Press the **>** key. Press the **^** or **∨** key until `> Code Set` appears.

```
>Code Set
  IBM PC-8
```

- 4** Press the **ENTER** key. A blinking question mark (?) appears.

```
>Code Set
?IBM PC-8
```

- 5** Press the **^** or **∨** key until the desired character code set appears.
- 6** Press the **ENTER** key.
- 7** Press the **MENU** key. The message display returns to `Ready`.

## Number of Copies

You can set the number of copies to be printed of each page for the current interface. The number of copies can be set between 1 and 999.

- 1 Press the **MENU** key.
- 2 Press the **^** or **v** key repeatedly until `Page set >` appears.

```
Page Set      >
```

- 3 Press the **>** key.
- 4 Press the **^** or **v** key repeatedly until `>Copies` appears.

```
>Copies      001
```

- 5 Press the **ENTER** key. A blinking cursor ( `_` ) appears.

```
>Copies      001
```

- 6 Press the **^** or **v** key to increase or decrease the value of the figure where the cursor is blinking. It can be set between 1 and 999. You can use the **>** and **<** keys to move the right and left.
- 7 When the desired size is displayed, press the **ENTER** key.
- 8 Press the **MENU** key. The message display returns to `Ready`.



## Printing Orientation

The default orientation of the page can be selected from the portrait (upright) and landscape (sideways) page orientation.

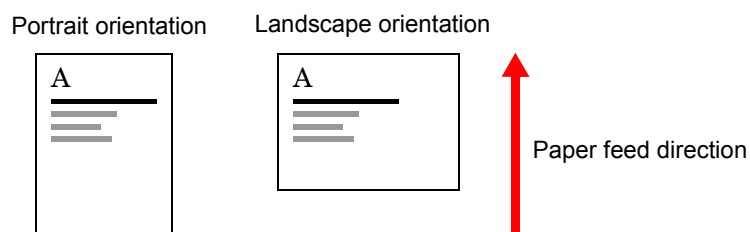

- 1** Press the **MENU** key.
- 2** Press the  $\wedge$  or  $\vee$  key repeatedly until Page Set > appears.
 

Page Set >
- 3** Press the > key.
- 4** Press the  $\wedge$  or  $\vee$  key repeatedly until >Orientation appears.
 

>Orientation  
Portrait
- 5** Press the **ENTER** key. A blinking question mark (?) appears.
 

>Orientation  
? Portrait
- 6** Select Portrait or Landscape using the  $\wedge$  or  $\vee$  key.
- 7** Press the **ENTER** key.
- 8** Press the **MENU** key. The message display returns to Ready.

## KIR (Kyocera Image Refinement)

This printer incorporates the KIR (Kyocera Image Refinement) smoothing function. This function provides high print quality by providing software enhancement of print resolution.



Set the print density to 3 when setting the KIR mode. For details on print density, see page 1-95.

Look at the check line, the last line on a status page, to make the optimum KIR mode setting.

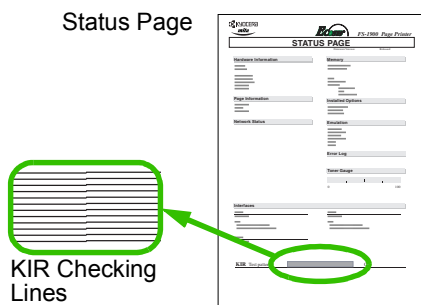

### Optimized stripes

The current KIR setting is optimal.

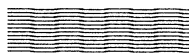

### Dark vertical stripes

Set the KIR mode to Off. Try printing the status page again. If you still get dark vertical stripes, adjust the print density control to a lighter setting.



### White vertical stripes

Set the KIR mode to On. Try printing the status page again. If you still get white vertical stripes, adjust the print density control to a darker setting.

- 1** Press the **MENU** key.
- 2** Press the  $\wedge$  or  $\vee$  key repeatedly until `Print Quality >` appears.

```
Print Quality >
```

- 3** Press the `>` key.
- 4** Press the  $\wedge$  or  $\vee$  key repeatedly until `>KIR Mode` appears.

```
>KIR Mode
  On
```

- 5** Press the **ENTER** key. A blinking question mark (?) appears.

```
>KIR Mode
? On
```

- 6** Select `On` or `Off` using the  $\wedge$  or  $\vee$  key.
- 7** Press the **ENTER** key.
- 8** Press the **MENU** key. The message display returns to `Ready`.

## Ecoprint

The Ecoprint enables you to reduce the amount of toner consumed on the page so as to save your printing costs. You can set to Ecoprint mode on, as follows. (The factory default setting is Off.)

The Ecoprint setting has no effect on the print speed.

The Ecoprint mode setting is On when the printing image becomes lighter, yet very readable.



Ecoprint setting is **Off**  
(default).



Ecoprint setting is **On**

- 1 Press the **MENU** key.
- 2 Press the ^ or v key repeatedly until Print Quality > appears.

```
Print Quality >
```

- 3 Press the > key.
- 4 Press the ^ or v key repeatedly until >Ecoprint Mode appears.

```
>Ecoprint Mode  
Off
```

- 5 Press the **ENTER** key. A blinking question mark (?) appears.

```
>Ecoprint Mode  
? Off
```

- 6 Select On or Off using the ^ or v key.
- 7 Press the **ENTER** key.
- 8 Press the **MENU** key. The message display returns to Ready.

## Resolution

Proceed as follows to set the default print resolution from four ways — 300 dpi, 600 dpi, and Fast 1200 mode. The clarity of printed characters and graphics becomes sharper in this order.

- 1** Press the **MENU** key.
- 2** Press the **^** or **v** key repeatedly until `Print Quality >` appears.

```
Print Quality >
```

- 3** Press the **>** key.
- 4** Press the **^** or **v** key repeatedly until `>Resolution` appears.

```
>Resolution
Fast 1200 mode
```

- 5** Press the **ENTER** key. A blinking question mark (?) appears.

```
>Resolution
? Fast 1200 mode
```

- 6** Select Fast 1200 mode, 300 dpi or 600 dpi using the **^** or **v** key.
- 7** Press the **ENTER** key.
- 8** Press the **MENU** key. The message display returns to Ready.

## e-MPS



To use the e-MPS system, an option Microdrive must be installed in the printer.

e-MPS is an abbreviation for 'enhanced-Multiple Printing System' which implements the following functions that are available from the printer driver:

- Job Retention
- Job Storage

In either job mode, when printing a document, the print data is transferred from the computer to the printer then stored on the printer's Microdrive. Since copies of the document are printed using the stored data, printing is performed faster with less computer spooling time and less network traffic.

### Job Retention

Job Retention has four modes as summarized below. These modes are selected when you choose on the printer driver through the application software:

Mode	Quick Copy	Proof and Hold	Private Print	Stored Job
Primary function	To later print additional copies	To proof the first copy before printing multiple copies	To hold the document in printer to prevent unauthorized access	To electronically store documents such as fax cover pages
Storing started	Printer driver	Printer driver	Printer driver	Printer driver
Retrieved by	Operator panel	Operator panel	Operator panel	Operator panel
Default number of copies printed at retrieval	Same as storing	One less	Same as storing	One
Maximum number of jobs stored*	32, expandable to 50	32, expandable to 50	Private jobs are deleted automatically once it is retrieved.	Depends on the capacity of Microdrive.
PIN security	No	No	Yes	Yes (Option)
Data after printing	Stored	Stored	Stored	Stored
Data at power off	Deleted	Deleted	Deleted	Stored
Microdrive required**	Yes	Yes	Yes	Yes

\* Jobs in excess will cause the earlier ones to be deleted.

\*\* RAM disk does not work for e-MPS.

## Job Storage

Job storage stores print jobs either temporarily or permanently, or in virtual mailboxes, as you click an appropriate radio button on the printer driver when printing from a computer.

## Virtual Mailbox

Virtual mailbox is part of Job Storage, which stores print jobs on the Microdrive without printing. It enables you to retrieve jobs later from the operator panel, or the *KM-NET Job Manager* utility (in the CD-ROM).

Each mailbox may be used by an individual who desires to share the printer in this mode. By default, each mailbox is numbered from 'Tray 001,' 'Tray 002,'... etc. To 'post' a job in one of these mailboxes, you assign a numbered mailbox on the printer driver when printing.

To retrieve the stored job for printing, see *Retrieving Jobs from Virtual Mailbox (VMB)* on page 1-68.



Note

**The virtual mailbox can be used in PCL 6 emulation only.**

## Quick Copy

This mode enables you to print the requested number of copies of a job, simultaneously storing the job on the Microdrive. When additional copies are required, you can reprint the required number of copies from the printer operator panel. To print a job as a quick copy job, see *Printer Driver Guide*.

The default number of print jobs that can be stored on the Microdrive is 32. This value can be increased to up to 50 from the e-MPS Configuration menu. For details, see *e-MPS Configuration* on page 1-70. When the number of jobs reaches the limit, the oldest job will be overwritten by the new one.

When the printer is turned off, all stored jobs will be deleted.

## Printing Additional Copies using Quick Copy

To print additional copies of a job stored in the printer:

- 1** Press the **MENU** key.
- 2** Press the **^** or **∨** key repeatedly until e-MPS > appears.

e-MPS >
---------

- 3** Press the **>** key.

- 4** Press the ^ or v key repeatedly until >Quick Copy appears followed by the user name (Harold, in this example). The user name is assigned at printing using the printer driver.

```
>Quick Copy
Harold
```

- 5** Press the **ENTER** key. A blinking question mark (?) appears before the user name.

```
>Quick Copy
?Harold
```

- 6** Press the ^ or v key to display the desired user name, Arlen, in this example.

```
>Quick Copy
?Arlen
```

- 7** Press the **ENTER** key. The job name entered in the printer driver (Report, in this example) appear with a blinking question mark (?) before the letters.

```
>Arlen
?Report
```

- 8** Press the ^ or v key to scroll to the desired job title.

- 9** Press the **ENTER** key. The number of copies to be printed can be set. To increase the copy count, press the ^ key; to decrease the copy count, press the v key.

```
>Report
Copies      001
```

- 10** Press the **ENTER** key to finalize the copy count. The printer prints the specified number of copies for the job.



### Deleting a Quick Copy Job

All quick copy jobs are automatically deleted when the printer is turned off. If you desire to explicitly delete a stored quick copy job, proceed as follows:

- 1 Follow steps 1 through 8 in the above section to let the title of the job displayed.
- 2 When the title of the job is displayed, e.g. Report, below, press the **ENTER** key. The cursor below the copy count starts to blink.

```
>Report
Copies      001
```

- 3 Press the  $\vee$  key repeatedly until Delete appears below the title.

```
>Report
Delete
```

- 4 Press the **ENTER** key. The stored quick copy job is deleted.

### Proof and Hold

When you print multiple copies, this mode first prints one copy so that you can proof it before continuing to print the remaining copies. Since you can proof the printouts before printing the remaining copies, wastage of paper can be reduced.

The printer prints one copy and, at the same time, saves the print job on the Microdrive. You can also change the number of copies when resuming printing from the operator panel.

When the printer is turned off, all stored jobs will be deleted.

### Printing Remaining Copies of a Proof and Hold Job

Printing a Proof and Hold job on the operator panel is similar to printing a quick copy job. To print remaining copies of a job held in the printer:

- 1 Press the **MENU** key.
- 2 Press the  $\wedge$  or  $\vee$  key repeatedly until e-MPS > appears.

```
e-MPS      >
```

- 3 Press the > key.

- 4** Press the ^ or v key repeatedly until >Quick Copy appears followed by the user name (Harold, in this example). The user name is assigned at printing using the printer driver.

```
>Quick Copy
Harold
```

- 5** Press the **ENTER** key. A blinking question mark (?) appears before the user name.

```
>Quick Copy
?Harold
```

- 6** Press the ^ or v key to display the desired user name, Arlen, in this example.

```
>Quick Copy
?Arlen
```

- 7** Press the **ENTER** key. The job name entered in the printer driver (Report, in this example) appear with a blinking question mark (?) before the letters.

```
>Arlen
?Report
```

- 8** Press the ^ or v key to scroll to the desired job title.

- 9** Press the **ENTER** key. The number of copies to be printed can be set. To increase the copy count, press the ^ key; to decrease the copy count, press the v key.

```
>Report
Copies      001
```

- 10** Press the **ENTER** key to finalize the copy count. The printer prints the specified number of copies for the job.

## Printing a Private Job

In private printing, you can specify that a job is not printed until you release the job from the operator panel. At sending the job from the application software, you should specify a 4-digit access code in the printer driver. The job is released for printing by entering the access code on the operator panel. Thus, this function ensures confidentiality of the print job.

When the printer is turned off, all the print jobs will be deleted.

### Releasing a Private Job

To print a private job through the operator panel:

- 1 Press the **MENU** key.
- 2 Press the **^** or **∨** key repeatedly until e-MPS > appears.

```
e-MPS >
```

- 3 Press the **>** key.
- 4 Press the **^** or **∨** key repeatedly until >Private/Stored appears. The name entered in the printer driver (Harold, in this example) also appears.

```
>Private/Stored
Harold
```

- 5 Press the **ENTER** key. A blinking question mark (?) before a user name appears.

```
>Private/Stored
?Harold
```

- 6 Press the **^** or **∨** key to display the desired user name (Arlen, in this example).

```
>Private/Stored
?Arlen
```

- 7 Press the **ENTER** key. The user name and the job name (Agenda, in this example) entered in the printer driver appear with a blinking question mark (?).

```
>Arlen
?Agenda
```

- 8** Press the  $\wedge$  or  $\vee$  key to display the desired job title.
- 9** Press the **ENTER** key. The ID input line appears. Enter the four-digit access code entered in the printer driver and press the **ENTER** key. To enter the ID, press the  $\lt$  or  $\gt$  key to move the cursor to the number to be changed and then enter the correct number by pressing the  $\wedge$  or  $\vee$  key.

```
>Agenda
ID          0000
```

- 10** You can set the number of copies to be printed. To increase the copy count, press the  $\wedge$  key; to decrease the copy count, press the  $\vee$  key.

```
>Agenda
Copies      001
```

- 11** Press the **ENTER** key to finalize the copy count. The printer prints the specified number of copies for the job.

### Deleting a Private Job

To delete a stored private job, proceed as follows:

- 1** Follow steps 1 through 8 in the above section.
- 2** When the title of the job to be printed is displayed (Agenda, in this example), press the **ENTER** key. Enter the four-digit access code entered in the printer driver and press the **ENTER** key.

```
>Agenda
Copies      001
```

- 3** Press the  $\vee$  key repeatedly until Delete appears for the number of copies.

```
>Agenda
Delete
```

- 4** Press the **ENTER** key. The private job is deleted from the Microdrive.

## Storing a Print Job

The procedure below allows you to store print jobs to the Microdrive that are frequently needed such as fax cover pages, check lists, and order forms, for printing at any later time using the operator panel.

The print jobs will not be deleted when the printer is turned off.

### Releasing a Stored Job

To print a stored job through the operator panel:

- 1 Press the **MENU** key.
- 2 Press the **^** or **∨** key repeatedly until e-MPS > appears.

```
e-MPS >
```

- 3 Press the **>** key.
- 4 Press the **^** or **∨** key repeatedly until >Private/Stored appears. The name entered in the printer driver (Harold, in this example) also appears.

```
>Private/Stored
Harold
```

- 5 Press the **ENTER** key. A blinking question mark (?) before a user name appears.

```
>Private/Stored
?Harold
```

- 6 Press the **^** or **∨** key to display the desired user name (Arlen, in this example).

```
>Private/Stored
?Arlen
```

- 7 Press the **ENTER** key. The user name and the job name (Agenda, in this example) entered in the printer driver appear with a blinking question mark (?).

```
>Arlen
?Agenda
```

- 8 Press the ^ or v key to display the desired job title.
- 9 Press the **ENTER** key. If you entered an access code for the printer driver, the ID input line appears. Enter the four-digit access code entered in the printer driver and press the **ENTER** key. To enter the ID, press the < or > key to move the cursor to the number to be changed and then enter the correct number by pressing the ^ or v key.

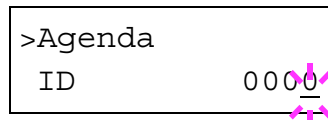

- 10 You can specify the number of copies to print. To increase the copy count, press the ^ key; to decrease the v key.

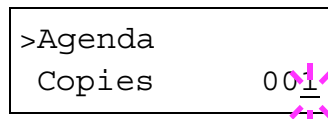

- 11 Press the **ENTER** key to finalize the copy count. The printer prints the specified number of copies for the job.

### Deleting a Stored Job

To delete a stored job, proceed as follows:

- 1 Follow steps 1 through 8 in the above section.
- 2 When the title of the job to be printed is displayed (Agenda, in this example), press the **ENTER** key. If you entered an access code for the printer driver, enter the four-digit access code and press the **ENTER** key.

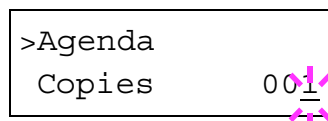

- 3 Press the v key repeatedly until Delete appears for the number of copies.

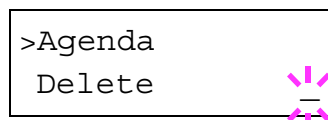

- 4 Press the **ENTER** key. The stored job is deleted from the Microdrive.

## Printing a Code Job

Install the KM-NET Job Manager software from the *Kyocera Mita Digital Library* CD-ROM supplied with the printer. To do this, from the CD-ROM **Main Menu**, select **Printer Utilities > Install KM-NET Job Manager**.

- 1** Browse through Windows **Start > Programs > KYOCERA MITA > KM-Net > Job Manager**.
- 2** Enter the password for the software. **Job Manager** will start.
- 3** Click the **Add printer** icon (below). Select the **Local** or **Network** port.



Note

If you use the local parallel port to connect to the printer, make sure that the printer driver is set to print to a local port. To check this out, click the **Details** tab of the printer **Properties**, and note the **Print to the following port** setting.

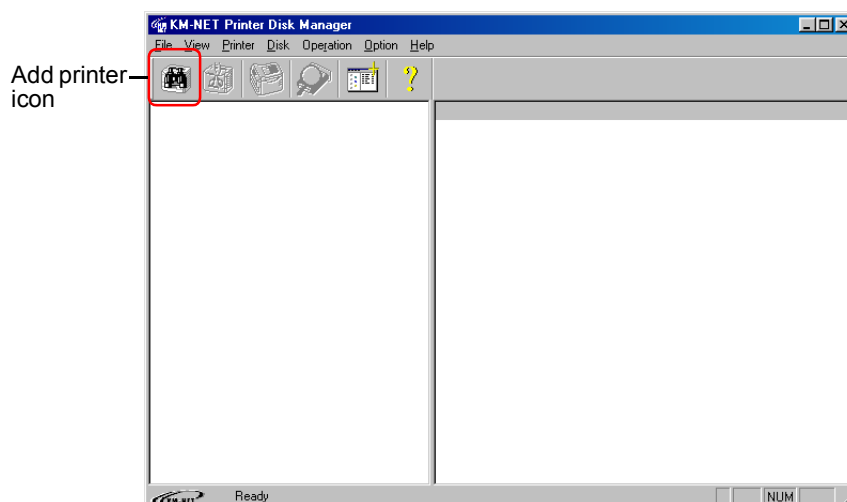

- 4** Follow the wizard until the **Select printer** dialog box is reached. When the printer is found in the **Printer List**, click (highlight) it, then **Finish**.

- 5** Double click **Model Name** on the list. The jobs currently stored in the printer are shown. To print the job, right click **Job name** and then click **Print** on the drop down list that appears.

It is possible to select more than one job at a time by right clicking a job one by one while pressing the Shift key on the computer keyboard.

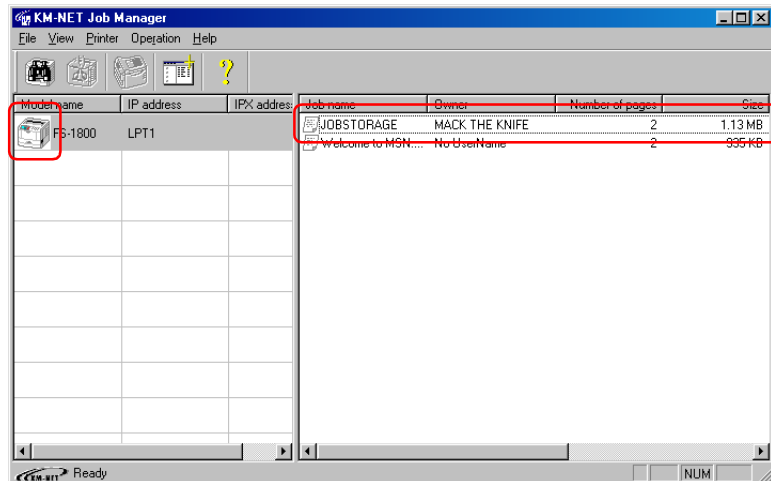

The job remains intact even after printing. To permanently delete the job in the hard disk, right click the job name on **Job Manager**, then click **Delete** on the drop down list that appears.



## Printing a List of Code Jobs

If you select Permanent Job Storage on the printer driver, you can have a List of Code Job printed using the operator panel.

**1** Press the **MENU** key.

**2** Press the  $\wedge$  or  $\vee$  key repeatedly until e-MPS > appears.

```
e-MPS >
```

**3** Press the > key.

**4** Press the  $\wedge$  or  $\vee$  key repeatedly until >List of Code JOB appears.

```
>List of  
Code JOB
```

**5** Press the **ENTER** key. A question mark (?) appears.

```
>List of  
Code JOB ?
```

**6** Press the **ENTER** key again. The printer prints a Code Job list.

## Retrieving Jobs from Virtual Mailbox (VMB)



To use this mode, an option Microdrive must be installed in the printer.

To retrieve the jobs posted in the virtual mailbox, proceed as follows.

- 1 Press the **MENU** key.
- 2 Press the **^** or **∨** key repeatedly until e-MPS > appears.

```
e-MPS >
```

- 3 Press the **>** key.
- 4 Press the **^** or **∨** key repeatedly until >Print VMB Data appears. The virtual mailbox number will also appear.

```
>Print VMB Data  
Tray001:
```

- 5 Press the **ENTER** key. A blinking question mark (?) appears.

```
>Print VMB Data  
Tray001?
```

- 6 Press the **ENTER** key. The document in the mailbox is printed and automatically deleted from the mailbox.

## Printing a List of VMB

A Virtual Mailbox list includes the jobs currently stored in the mailboxes.

- 1 Press the **MENU** key.
- 2 Press the **^** or **∨** key repeatedly until e-MPS > appears.

```
e-MPS      >
```

- 3 Press the **>** key.
- 4 Press the **^** or **∨** key repeatedly until >List of VMB appears.

```
>List of VMB
```

- 5 Press the **ENTER** key. A question mark (?) appears.

```
>List of VMB ?
```

- 6 Press the **ENTER** key again. The printer prints a list of jobs currently posted in the virtual mailboxes.

## e-MPS Configuration



You can change the following parameters for e-MPS operation:

- Maximum number of Quick Copy/Proof and Hold jobs
- Maximum space assigned to temporary code jobs
- Maximum space assigned to permanent code jobs
- Maximum space assigned to virtual mailboxes



The total amount of storage areas specified must not exceed the total size of the Microdrive. Otherwise, you may only be able to accommodate print jobs of a smaller amount of print jobs than specified.

### Changing the Maximum Number of Quick Copy/Proof and Hold Jobs

This changes maximum number of Quick Copy/Proof and Hold jobs from 0 to 50. The default is 32.

- 1 Press the **MENU** key.
- 2 Press the **^** or **∨** key repeatedly until `e-MPS >` appears.

```
e-MPS >
```

- 3 Press the **>** key.
- 4 Press the **^** or **∨** key repeatedly until `>e-MPS Configuration >` appears.

```
>e-MPS >  
Configuration
```

- 5 Press the **>** key.
- 6 Press the **^** or **∨** key repeatedly until `>>Quick Copy` appears.

```
>>Quick Copy  
32
```

- 7 Press the **ENTER** key. A blinking cursor (`_`) appears.

```
>>Quick Copy  
32
```

- 8 Press the **^** or **∨** key to increase or decrease the value at the blinking cursor. The value can be set between 0 and 50. Use the **>** and **<** keys to move the cursor right and left.
- 9 When the desired maximum number of jobs is set, press the **ENTER** key.
- 10 Press the **MENU** key. The message display returns to Ready.

### Maximum Space Assigned to Temporary Code Jobs

This changes the Microdrive space that holds temporary code jobs. You can change the maximum space from 0 to 9999 (megabytes). The actual maximum size depends on the size of free hard disk space, however. The default size is 50 MB.

- 1 Press the **MENU** key.
- 2 Press the **^** or **∨** key repeatedly until e-MPS > appears.

```
e-MPS      >
```

- 3 Press the **>** key.
- 4 Press the **^** or **∨** key repeatedly until >e-MPS Configuration > appears.

```
>e-MPS      >
Configuration
```

- 5 Press the **>** key.
- 6 Press the **^** or **∨** key repeatedly until >>Temp. Code JOB Size appears.

```
>>Temp. Code JOB
Size      050MB
```

- 7 To change the maximum disk space, press the **ENTER** key. A blinking cursor ( **\_** ) appears.

```
>>Temp. Code JOB
Size      050MB
```

- 8** Press the ^ or v key to increase or decrease, respectively, the value at the blinking cursor. Use the > and < keys to move the cursor right and left.
- 9** When the desired size is displayed, press the **ENTER** key.
- 10** Press the **MENU** key. The message display returns to Ready.

### Maximum Space Assigned to Permanent Code Jobs

This changes the Microdrive space that holds permanent code jobs. You can change the maximum space from 0 to 9999 (megabytes). The actual maximum size depends on the size of free Microdrive space, however. The default size is 50 MB.

- 1** Press the **MENU** key.
- 2** Press the ^ or v key repeatedly until e-MPS > appears.

```
e-MPS      >
```

- 3** Press the > key.
- 4** Press the ^ or v key repeatedly until >e-MPS Configuration > appears.

```
>e-MPS      >
Configuration
```

- 5** Press the > key.
- 6** Press the ^ or v key repeatedly until >>Perm. Code JOB Size appears.

```
>>Perm. Code JOB
Size          050MB
```

- 7** Press the **ENTER** key. A blinking cursor ( \_ ) appears.

```
>>Perm. Code JOB
Size          050MB
```

- 8** Press the ^ or v key to increase or decrease, respectively, the value at the blinking cursor. Use the > and < keys to move the cursor right and left.

- 9 When the desired size is displayed, press the **ENTER** key.
- 10 Press the **MENU** key. The message display returns to Ready.

### Maximum Space Assigned to Virtual Mailboxes

This changes the Microdrive space for virtual mailboxes. You can change the maximum space from 0 to 9999 (megabytes). The actual maximum size depends on the size of free Microdrive space, however. The default size is 50 MB.

- 1 Press the **MENU** key.
- 2 Press the **^** or **v** key repeatedly until e-MPS > appears.

```
e-MPS >
```

- 3 Press the **>** key.
- 4 Press the **^** or **v** key repeatedly until >e-MPS Configuration > appears.

```
>e-MPS >
Configuration
```

- 5 Press the **>** key.
- 6 Press the **^** or **v** key repeatedly until >>VMB Size appears.

```
>>VMB Size
050MB
```

- 7 Press the **ENTER** key. A blinking cursor (    ) appears.

```
>>VMB Size
050MB
```

- 8 Press the **^** or **v** key to increase or decrease, respectively, the value at the blinking cursor. Use the **>** and **<** keys to move the cursor right and left.
- 9 When the desired size is displayed, press the **ENTER** key.
- 10 Press the **MENU** key. The message display returns to Ready.

## Interface

The printer is equipped with both a parallel and USB interface. Option serial interface board kit and network interface card can also be installed. Various printing environment parameters such as the default emulation can be changed independently on different interfaces by using the printer's menu selection system. Before select the interface to apply the changes in the procedure described below.



Note

**This interface selection described below does not select which interface data will be received from. The printer automatically selects an interface data is received.**

### Parallel Interface Mode

The parallel interface mode of this printer supports a bi-directional/high-speed mode. Normally, this interface is used under the default setting AUTO. For details, see [Appendix C](#). After setting the interface, be sure to reset the printer or turn the power off at least once. The new setting will be enabled thereafter.

- 1 Press the **MENU** key.
- 2 Press the **^** or **v** key repeatedly until `Interface >` appears. One of the interface names shown below appears, indicating the current interface.

```
Parallel (default)
USB
Serial (when a serial interface board kit is installed)
Option (when a network interface card is installed)
```

- 3 Press the **ENTER** key. A blinking question mark (?) appears.

```
Interface
? Parallel
```

If `Parallel` is not displayed, press the **^** or **v** key repeatedly until it is `Parallel`.

If you want to abandon the interface selection procedure, press the **CANCEL** key. The interface remains unchanged.

- 4 Press the **ENTER** key again.
- 5 Press the **>** key. The message display changes to the communication mode menu.



- 6** Press the **ENTER** key. A blinking question mark (?) appears.

```
>Parallel I/F
? AUTO
```

- 7** Press the ^ or v key to display the desired mode. The display changes as shown below. Press the **ENTER** key.

```
AUTO (default)
Normal
High Speed
Nibble (high)
```

- 8** Press the **MENU** key. The message display returns to Ready.

## USB Interface Mode

About USB interface, for details, see [Appendix C](#).

- 1** Press the **MENU** key.
- 2** Press the ^ or v key until Interface > appears. One of the interface names shown below appears, indicating the current interface.

```
Parallel (default)
USB
Serial (when a serial interface board kit is installed)
Option (when a network interface card is installed)
```

- 3** Press the **ENTER** key. A blinking question mark (?) appears.

```
Interface
? Parallel
```

- 4** Press the ^ or v key until USB appears.

```
Interface
? USB
```

- 5** Press the **ENTER** key.
- 6** Press the **MENU** key. The message display returns to Ready.

## Serial Interface Parameters



This section applies to the printers having the option serial interface board kit (IB-10E) installed.

The baud rate, data bits, stop bits, parity, and protocol for the serial interface can be set as follows:

- 1 Press the **MENU** key.
- 2 Press the **^** or **∨** key repeatedly until `Interface >` appears. One of the interface names shown below appears, indicating the current interface.

Parallel (default)  
USB  
Serial (when a serial interface board kit is installed)  
Option (when a network interface card is installed)

- 3 Press the **ENTER** key. A blinking question mark (?) appears.

```
Interface
? Parallel
```

If you want to abandon the interface selection procedure, press the **CANCEL** key. The interface remains unchanged.

- 4 Press the **^** or **∨** key repeatedly until `Serial` appears.

```
Interface
? Serial
```

- 5 Press the **ENTER** key again.

- 6** Press the > key. Each time the ^ or v key is pressed, the setting item and current setting change as shown below.

```
>Baud Rate
  9600
```

Definable baud rates: 1200, 2400, 4800, 9600 (default), 19200, 38400, 57600, 115200



```
>Data Bits
  8
```

Definable data bits: 7, 8 (default)



```
>Stop Bits
  1
```

Definable stop bits: 1 (default), 2



```
>Parity
  None
```

Definable parity: None (default), Odd, Even, Ignore



```
>Protocol
  DTR (pos.) &XON
```

Definable protocol: DTR (pos.) &XON (default), DTP (positive), DTR (negative), XON/XOFF, ETX/ACK

- 7** Display the setting item to be changed and press the **ENTER** key. A question mark (?) appears.

The following example explains how to change the baud rate. The settings for other items can be changed in a similar manner.

```
>Baud Rate
?  9600
```

- 8** Press the ^ or v key to display the desired setting. The setting changes as shown below.

The baud rate can be selected from 1200, 2400, 4800, 9600 (default), 19200, 38400, 57600, and 115200.



Note

- Some computers may not be compatible with a baud rate of 115200 bps. If you set the baud rate to 115200 and communication problems occur, lower the baud rate.**

- 9** Display the desired baud rate and press the **ENTER** key.
- 10** Press the **MENU** key. The message display returns to Ready.

## Network Interface Parameters



**This section applies to the printers having the option network card installed.**

To make your printer supports TCP/IP, Netware, and EtherTalk networks, you will need to install the option network interface card in the printer and make the proper settings as explained in this section.

Using the operator panel, you can:

- Activate or deactivate TCP/IP, NetWare, and EtherTalk
- Activate or deactivate DHCP
- Enter IP address, subnet mask address, and default gateway address

To confirm or change network card parameters, proceed as follows:

- 1** Press the **MENU** key.
- 2** Press the  $\wedge$  or  $\vee$  key repeatedly until `Interface >` appears. One of the interface names shown below appears, indicating the current interface.

```
Parallel (default)
USB
Serial (when a serial interface board kit is installed)
Option (when a network interface card is installed)
```

- 3** Press the **ENTER** key. A blinking question mark (?) appears.



```
Interface
? Parallel
```

- 4** Press the  $\wedge$  or  $\vee$  key repeatedly until `Option` appears.

```
Interface
? Option
```

- 5** Press the **ENTER** key again.

- 6** Press the > key. Each time the ^ or v key is pressed, the display changes as shown below.

>NetWare > On	<p><b>Range</b></p> <p>Set this item to On when you connect to a network using NetWare. In submenu (&gt;), frame mode can be selected from Auto, Ethernet, 802.2, and 802.3.</p>
	
>TCP/IP > On	<p>Set this item to On when you connect to a network using TCP/IP. Submenu (&gt;) has items including DHCP, IP address, subnet mask address, and gateway address.</p>
	
>EtherTalk Off	<p>EtherTalk must be activated (On) for networking with Macintosh computers.</p>
	
>Opt. StatusPage On	<p>When the item is set to On, the printer prints out a network status page when it prints the printer status. See page <a href="#">1-19</a></p>

- 7** The following example explains how to activate TCP/IP protocol to connect the printer in the network. You can select Netware or EtherTalk in a similar manner.

>TCP/IP >  
On

If TCP/IP is currently Off is displayed, select On using the ^ or v key. Press the **ENTER** key again.

>TCP/IP ? On		>TCP/IP > On
-----------------	---	-----------------

- 8** Press the > key. Each time the ^ or v key is pressed, the item changes as shown below.

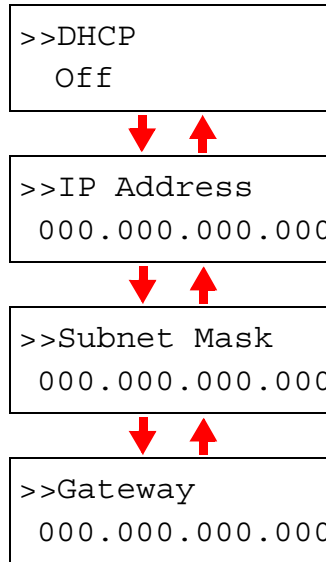

- 9** Display the item to be set and press the **ENTER** key. For DHCP, a question mark (?) appears. For IP Address, Subnet Mask, and Gateway, the cursor ( \_ ) blinks.
- 10** For DHCP, select On or Off using the ^ or v key. For IP Address, Subnet Mask, and Gateway addresses, press the ^ or v key to change the number (000 to 255) where the cursor is blinking. You can use the > and < key to move the cursor right and left.

To obtain these addresses, consult your network administrator.

- 11** Press the **ENTER** key.
- 12** Press the **MENU** key. The message display returns to Ready.

## Operating the Storage Device

The printer supports three types of storage devices: CompactFlash card, Microdrive, and RAM disk.

The printer is equipped with a slot for a CompactFlash card and a Microdrive. By inserting a CompactFlash card or Microdrive into the printer, the following operations become available. For details about the handling of the CompactFlash card and Microdrive, see [Appendix B](#).

The following procedure assumes use of a CompactFlash card. The similar procedure can be applied when using the Microdrive.



Note

**You can format the Microdrive using the operator panel when the first time you installed a new Microdrive. About formatting a new Microdrive.**

### Activating the RAM Disk

The RAM disk is a memory space shared within the printer memory that can temporarily store print jobs for electronic sorting. The stored print job can then be used to print multiple copies of the job reducing the total amount of period required to print the whole job. It acts similar to the option Microdrive except that the data is effective only during the printer is powered up.

To set up the RAM disk, the option Microdrive must not be installed.

To use the RAM disk, activate and enter the desired size of the RAM disk in the manner described below. The maximum RAM disk size can be calculated as follows:

Maximum RAM size = Total printer memory - 9 MB

For example, if the total memory installed in your printer is 144 MB, you can set 135 MB of RAM disk. If you attempt to set the RAM disk size beyond this restriction, the printer automatically round it down so that the size is always 9 MB less than the total printer memory. Once the RAM disk size is set, the printer must be reset.

By default, the RAM disk is not activated (Off). To confirm the RAM disk size or activate the RAM disk, proceed as follows:

- 1** Press the **MENU** key.
- 2** Press the **^** or **∨** key repeatedly until RAM Disk Mode > appears.

RAM Disk Mode Off
----------------------

- 3** The default setting is Off. Press the **ENTER** key. A blinking question mark (?) appears. Select On using the ^ or v key, and then press the **ENTER** key.

```
RAM Disk Mode
? On
```

- 4** Press the > key to display >RAM Disk Size.

```
>RAM Disk Size
      0007 Mbyte
```

- 5** Press the **ENTER** key again, and change the RAM disk size using the ^ or v key. It is not possible to make a setting that exceeds total printer memory. The default value for the RAM disk is the total printer memory minus 9 MB. This parameter may be set anywhere from 0001 to 1024 depending on the available printer memory.

- 6** When the desired RAM disk size is displayed, press the **ENTER** key.

- 7** Press the **MENU** key and restart the printer. The setting will be activated after restart.



## Reading Data

To read data on a CompactFlash card, Microdrive, or the RAM disk use the following procedure:

- 1** Press the **MENU** key.
- 2** Press the **^** or **∨** key repeatedly until Memory Card >, Hard Disk > or RAM Disk Mode > appears.

```
Memory Card >
```

- 3** Press the **>** key.
- 4** Press the **^** or **∨** key repeatedly until >Read Data appears. The data name also appears.

```
>Read Data  
data name
```

- 5** Press the **ENTER** key. A blinking question mark (?) appears before the data name.

```
>Read Data  
?data name
```

- 6** Press the **^** or **∨** key to display the desired data name.
- 7** Press the **ENTER** key. Processing appears and the reading of data from the storage device starts.

## Writing Data

You can write data to a CompactFlash card, the Microdrive, or the RAM disk using the operator panel. When writing data to the storage device, a name is automatically assigned to the data. The CompactFlash card or the Microdrive or the RAM disk must be formatted. Otherwise, the >Write Data message explained below will not appear on the display. To format a CompactFlash card or the Microdrive or the RAM disk, see [Formatting a Storage Device](#) on page 1-88.



Note

**You can format the Microdrive or the RAM disk using the operator panel when the first time you installed a new Microdrive or the RAM disk. About formatting a new Microdrive.**

After writing is complete, you can print a list of data stored in the storage device for confirmation. See [Printing a List of Data Names](#) on page 1-89.

To write data to a CompactFlash card, the Microdrive or the RAM disk, proceed as follows:

- 1 Press the **MENU** key.
- 2 Press the ^ or v key repeatedly until Memory Card >, Hard Disk > or RAM Disk Mode > appears.

```
Memory Card >
```

- 3 Press the > key.
- 4 Press the ^ or v key repeatedly until >Write Data appears.

```
>Write Data
```

- 5 Press the **ENTER** key. A question mark (?) appears.

```
>Write Data ?
```

- 6 Press the **ENTER** key. Processing appears, then Waiting.

## 7 In this state, send the file from the computer to the printer.

The file is written onto the storage device given a destination name (also referred to as a partition name) which the printer automatically assigns one after another as follows:

DataS001 (first data),  
DataS002 (second data),  
DataS003 (third data)...

In the example above, if the file *TEST.TXT* is the first data to be written onto the storage device, the destination name will be *DataS001*.

As the printer receives data, the message display changes to Processing, then when the end of the data is received, the message display changes to Waiting.

## 8 Check that the message display has changed to Waiting, then press the GO key. This writes the file to the memory card and instructs the printer to automatically print out a CompactFlash card write information page as shown below.

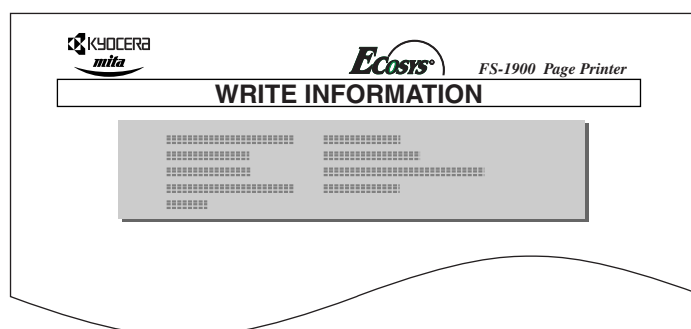

**Partition Type.** Type of data written (currently only type 2 is supported).

**Partition Name.** Name of data written.

**Write Partition Length.** Length (size) of the data written.

**Others.** Additional information, such as error information.

When the write information page is printed, the message display returns to Ready.

If the writing was not completed successfully, an error code appears on the message display. For details, see [Error Messages](#) on page 4-10. If this happens, press the GO key. The message display returns to Ready.

- Repeat above steps until you have transferred all data (files) that you want to write to the CompactFlash card. Each time you finish writing data, a CompactFlash card write information page is printed from the printer showing the information explained in step 4 above, but pertaining only to the data just written. To see all data contained in the CompactFlash card at once, print a list of data names as explained on page [1-89](#), *Printing a List of Data Names*.

## Deleting Data

You can use the printer's operator panel to delete data from a CompactFlash card, the Microdrive or the RAM disk.

- Press the **MENU** key.
- Press the **^** or **v** key repeatedly until Memory Card >, Hard Disk > or RAM Disk Mode > appears.

```
Memory Card >
```

- Press the **>** key.
- Press the **^** or **v** key repeatedly until > Delete Data appears. The data name also appears.

```
>Delete Data  
data name
```

- Press the **ENTER** key. A blinking question mark (?) appears before the data name.

```
>Delete Data  
?data name
```

- Press the **^** or **v** key to display the desired data name.
- Press the **ENTER** key. Processing appears and the data is deleted from the CompactFlash card.

## Reading Fonts from a CompactFlash Card

If a font (CompactFlash) card is already inserted into the slot when the printer is turned on, the fonts are automatically read into the printer.

To re-read fonts into the printer from a CompactFlash card, proceed as follows.

- 1 Press the **MENU** key.
- 2 Press the **^** or **v** key repeatedly until `Memory Card >` appears.

```
Memory Card >
```

- 3 Press the **>** key.
- 4 Press the **^** or **v** key repeatedly until `>Read fonts` appears.

```
>Read fonts
```

- 5 Press the **ENTER** key. A question mark (?) appears.

```
>Read fonts ?
```

- 6 Press the **ENTER** key. Processing appears and the reading of fonts from the CompactFlash card starts.
- 7 When the reading of fonts ends, the message display returns to `>Read fonts`.
- 8 Press the **MENU** key. The message display returns to `Ready`.

## Formatting a Storage Device

A new CompactFlash card or Microdrive must be formatted before it can be used in the printer. You can format the storage device using the printer operator panel.



- **Formatting will destroy any existing data on a storage device.**
- **You can format the Microdrive using the operator panel when the first time you installed a new Microdrive. About formatting a new Microdrive.**

To format a CompactFlash card or the Microdrive, use the following procedure:

- 1** Press the **MENU** key.
- 2** Press the **^** or **∨** key repeatedly until `Memory Card >` or `Hard Disk >` appears.

```
Memory Card >
```

- 3** Press the **>** key.
- 4** Press the **^** or **∨** key repeatedly until `>Format` appears.

```
>Format
```

- 5** Press the **ENTER** key. A question mark (?) appears.

```
>Format ?
```

- 6** Press the **ENTER** key. Processing appears and formatting of the CompactFlash card starts.

When the formatting is successfully completed, the printer automatically prints out a format information page as shown below.

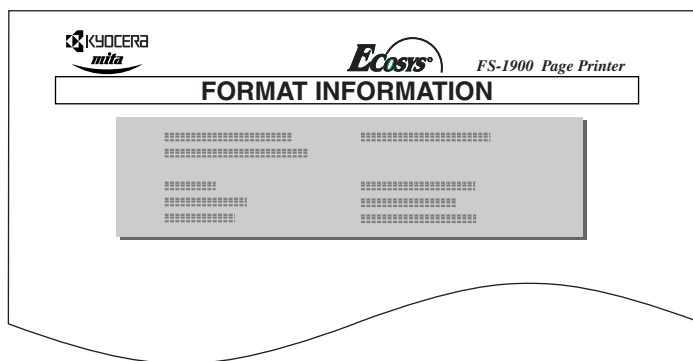

**Capacity.** The total size of the CompactFlash card or the Microdrive memory.

**Used Space.** The size the printer uses for its system.

**Free Space.** The size remaining in the CompactFlash card or the Microdrive for storing data.

When the format information is printed, the message display returns to Ready.

## Printing a List of Data Names

The printer prints a list of all data names (referred to as partitions) stored in the storage device for reference. (Printing a list is also available for a font card.)

To print a list of data names for the CompactFlash card, the Microdrive, or the RAM disk proceed as follows.

- 1** Press the **MENU** key.
- 2** Press the **^** or **∨** key repeatedly until Memory Card >, Hard Disk >, or RAM Disk Mode > appears.

```
Memory Card >
```

- 3** Press the **>** key.
- 4** Press the **^** or **∨** key repeatedly until >List of Partitions appears.

```
>List of
Partitions
```

- 5** Press the **ENTER** key. A question mark (?) appears.

```
>List of
Partitions ?
```

- 6** Press the **ENTER** key. Processing appears and the printing of the list starts.

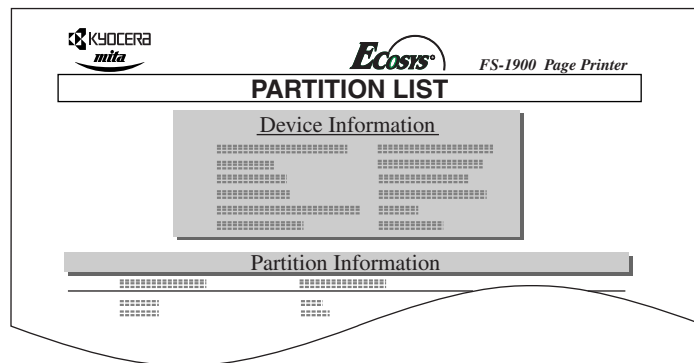

The list provides the following information that are automatically generated by the printer about data currently stored in the storage device:

- Device Name/Number.** Description for the storage device. For example, 'MEMORY CARD/A' is indicated for a memory card.
- Capacity.** Total capacity of the storage device in bytes.
- Used Space.** The total space used for data stored in the storage device in bytes.
- Free Space.** The space remaining in the storage device for storing more data, including the memory space required by the printer for its file system.
- Partition Name.** The name assigned automatically by the printer for written data.
- Partition Size.** Size of the written data in bytes.
- Partition Type.** The type identifying the written data, i.e., whether it is host data (Data) or font data (Font).

When the list of file names (partition list) for the storage device is printed, the display returns to Ready.



## Configuration

This section explains the details of printer settings. The following items are covered.

- Page Protect Mode
- Linefeed (LF) Action
- Carriage-Return (CR) Action
- Wide A4 Pitch
- Print Density
- Total Printed Pages
- Toner Counter Resetting
- Message Language
- Automatic Form Feed Timeout
- Sleep Timer Setting
- Printer Resetting
- Resource Protection
- Alarm (Buzzer) Setting
- Auto Continue Setting

### Page Protect Mode

The Page Protect Menu does not normally appear, however, Page Protect will be forcibly set to On if a print overrun error occurs due to insufficient printer memory. When this has happened, be sure to reset Page Protect to Auto (default) in order to maintain the optimum use of printer memory.

- 1** Press the **MENU** key.
- 2** Press the **^** or **∨** key repeatedly until `Page set >` appears.

```
Page set >
```

- 3** Press the **>** key.
- 4** Press the **^** or **∨** key repeatedly until `>Page Protect` appears.

```
>Page Protect
  On
```

- 5** Press the **ENTER** key. A blinking question mark (?) appears.

```
>Page Protect
? On
```

- 6** Press the  $\wedge$  or  $\vee$  key repeatedly until `Auto` appears.

```
>Page Protect
? Auto
```

- 7** Press the **ENTER** key.

- 8** Press the **MENU** key. The message display returns to `Ready`.

## Linefeed (LF) Action

This procedure instructs the printer what to do when it receives a linefeed code (character code 0AH).

- 1** Press the **MENU** key.

- 2** Press the  $\wedge$  or  $\vee$  key repeatedly until `Page set >` appears.

```
Page set >
```

- 3** Press the `>` key.

- 4** Press the  $\wedge$  or  $\vee$  key repeatedly until `>LF Action` appears.

```
>LF Action
LF only
```

- 5** Press the **ENTER** key. A blinking question mark (?) appears.

```
>LF Action
? LF only
```

- 6** Press the  $\wedge$  or  $\vee$  key repeatedly until desired linefeed action appears.

LF only	A linefeed is performed. (default)
CR and LF	A linefeed and carriage return are performed.
Ignore LF	The linefeed is ignored.

- 7** When the desired action is displayed, press the **ENTER** key.

- 8** Press the **MENU** key. The message display returns to `Ready`.

## Carriage-Return (CR) Action

This procedure instructs the printer what to do when it receives a carriage-return code (character code 0DH)

- 1 Press the **MENU** key.
- 2 Press the **^** or **v** key repeatedly until `Page set >` appears.

```
Page set >
```

- 3 Press the **>** key.
- 4 Press the **^** or **v** key repeatedly until `>CR Action` appears.

```
>CR Action
CR only
```

- 5 Press the **ENTER** key. A blinking question mark (?) appears.

```
>CR Action
? CR only
```

- 6 Press the **^** or **v** key repeatedly until desired carriage-return action appears.

CR only	A carriage-return is performed. (Default)
CR and LF	A carriage-return and linefeed are performed.
Ignore CR	The carriage-return code is ignored.

- 7 When the desired action is displayed, press the **ENTER** key.
- 8 Press the **MENU** key. The message display returns to `Ready`.

## Wide A4 Pitch

Turn this to On to increase the maximum number of characters that can be printed in a line for A4 page (78 characters at 10 pitch) and Letter size page (80 characters at 10 pitch). This setting is effective in only PCL 6 emulation.

- 1** Press the **MENU** key.
- 2** Press the  $\wedge$  or  $\vee$  key repeatedly until Page set > appears.

```
Page set      >
```

- 3** Press the > key.
- 4** Press the  $\wedge$  or  $\vee$  key repeatedly until >Wide A4 appears.

```
>Wide A4
  Off
```

- 5** Press the **ENTER** key. A blinking question mark (?) appears.

```
>Wide A4
? Off
```

- 6** Select On or Off using the  $\wedge$  or  $\vee$  key.
- 7** Press the **ENTER** key.
- 8** Press the **MENU** key. The message display returns to Ready.

## Print Density

The print density can be adjusted in five steps: from 01 (light) to 05 (dark). The factory setting is 03.

- 1 Press the **MENU** key.
- 2 Press the ^ or v key repeatedly until Print Quality > appears.

```
Print Quality >
```

- 3 Press the > key.
- 4 Press the ^ or v key repeatedly until >Print Density appears.

```
>Print Density  
03
```

- 5 Press the **ENTER** key. A blinking question mark (?) appears.

```
>Print Density  
? 03
```

- 6 Select the print density from five steps from 01 (light) to 05 (dark) using the ^ or v key.
- 7 Press the **ENTER** key.
- 8 Press the **MENU** key. The message display returns to Ready.

## Total Printed Pages

This procedure displays the total number of printed pages.

- 1 Press the **MENU** key.
- 2 Press the  $\wedge$  or  $\vee$  key repeatedly until `Life Counters >` appears.

```
Life Counters >
```

- 3 Press the  $>$  key.
- 4 Press the  $\wedge$  or  $\vee$  key repeatedly until `>Total Print` appears, the total number of printed pages displayed.

```
>Total Print  
0012345
```

- 5 Press the **MENU** key. The message display returns to `Ready`.

## Toner Counter Resetting

When the toner container is replaced, reset the toner counter as follows so that an accurate toner gauge measurement is indicated on the status page. Note that if this operation is performed when the toner container is not replaced, the toner gauge measurement will not be indicated correctly.

Also refer to the *Installation Guide* supplied with the toner kit when replacing the toner container.

- 1 Press the **MENU** key.
- 2 Press the  $\wedge$  or  $\vee$  key repeatedly until `Life Counters >` appears.

```
Life Counters >
```

- 3 Press the  $>$  key.
- 4 Press the  $\wedge$  or  $\vee$  key repeatedly until `>New Toner Installed` appears

```
>New Toner  
Installed
```

- 5** Press the **ENTER** key. A question mark (?) appears.

```
>New Toner
  Installed ?
```

- 6** Press the **ENTER** key. The toner counter is reset. The message display returns to Ready.

## Message Language

You can select the language of the messages on the message display by following the procedure given below. You can optionally download messages in order language. Contact your Kyocera Mita dealer for information.

- 1** Press the **MENU** key.
- 2** Press the **^** or **v** key repeatedly until **Others >** appears.

```
Others >
```

- 3** Press the **>** key.
- 4** Press the **^** or **v** key repeatedly until **>MSG Language** appears. The default message language is English.

```
>MSG Language
  English
```

- 5** To change the language, press the **ENTER** key. A blinking question mark (?) appears.

```
>MSG Language
? English
```

- 6** Press the  $\vee$  key. The display cycles through the available selections in the following order (The  $\wedge$  key cycles in the reverse order):

>MSG Language  
? English



>Langue  
? Francais



>Anzeigesprache  
? Deutsch



>Lingua  
? Italiano



>Idioma  
? Español

- 7** Press the **ENTER** key.

- 8** Press the **MENU** key. The message display returns to Ready.



## Automatic Form Feed Timeout

When the printer receives no data for a certain time, it time out and releases the current interface: it prints whatever data it has in its buffer and feeds out the page. You can adjust the time-out time as follows:

- 1 Press the **MENU** key.
- 2 Press the  $\wedge$  or  $\vee$  key repeatedly until Others > appears.

```
Others >
```

- 3 Press the > key.
- 4 Press the  $\wedge$  or  $\vee$  key repeatedly until >Form Feed Time appears. The default setting is 30 seconds.

```
>Form Feed  
Time Out 030sec.
```

- 5 Press the **ENTER** key. A blinking cursor (    ) appears.

```
>Form Feed Time.  
Time Out 030sec.
```

- 6 Press the  $\wedge$  or  $\vee$  key to increase or decrease the value of the figure where the cursor is blinking and set the desired time. The time can be set between 0 and 495 seconds, in 5-second increments. You can use the > and < keys to move the cursor right and left.
- 7 Display the desired time and press the **ENTER** key.
- 8 Press the **MENU** key. The message display returns to Ready.

## Sleep Timer Setting

The printer has a sleep timer to conserve power when the printer is not printing, processing, or receiving data. You can adjust the timer value, the length of time the printer waits before entering sleeping mode in the absence of data.

- 1 Press the **MENU** key.
- 2 Press the **^** or **v** key repeatedly until `Others >` appears.

```
Others >
```

- 3 Press the **>** key.
- 4 Press the **^** or **v** key repeatedly until `>Sleep Timer >` appears. The default setting is 015 min.

```
>Sleep Timer >  
015 min.
```

- 5 Press the **ENTER** key. A blinking cursor ( **\_** ) appears.

```
>Sleep Timer  
015 min.
```

- 6 Press the **^** or **v** key to increase or decrease the value of the figure where the cursor is blinking and set the desired time. The timer can be set between 5 and 240 min, in 5-minute increments. You can use the **>** and **<** keys to move the cursor right and left.
- 7 Press the **ENTER** key.
- 8 Press the **MENU** key. The message display returns to `Ready`.

### Turning Off the Sleep Timer

You can turn off the sleep timer function by following the procedure given below.

- 1 Press the **MENU** key.
- 2 Press the **^** or **∨** key repeatedly until `Others >` appears.

```
Others >
```

- 3 Press the **>** key.
- 4 Press the **^** or **∨** key repeatedly until `>Sleep Timer >` appears.

```
>Sleep Timer >  
015 min.
```

- 5 Press the **>** key and display `>>Sleep Mode.`

```
>>Sleep Mode  
On
```

- 6 Press the **ENTER** key. A blinking question mark (?) appears.

```
>>Sleep Mode  
? On
```

- 7 Select `Off` using the **^** or **∨** key.

```
>>Sleep Mode  
? Off
```

- 8 Press the **ENTER** key.
- 9 Press the **MENU** key. The message display returns to `Ready`.

## Printer Resetting

The procedure described below resets the printer's temporary conditions, such as the current unit of measurement, page orientation, font, character code set, margins, etc., set by commands to their default values.

- 1** Press the **MENU** key.
- 2** Press the **^** or **∨** key repeatedly until `Others >` appears.

```
Others >
```

- 3** Press the **>** key.
- 4** Press the **^** or **∨** key repeatedly until `>Printer Reset` appears.

```
>Printer Reset
```

- 5** Press the **ENTER** key. A question mark (?) appears.

```
>Printer Reset ?
```

- 6** Press the **ENTER** key again. `Self test` appears while the printer is resetting itself, then `Please wait` followed by `Ready`.

```
Self test
```



```
Please wait
```



```
Ready
```

## Resource Protection

When you switch from the PCL 6 emulation to another, all downloaded fonts and macros are lost. Resource protection preserves these PCL resources in memory so that they are intact when you change the emulation back to PCL 6.



Note

**Resource protection requires extra memory to store the downloaded fonts and macros. The total size of the printer memory recommended for using the resource protection option is affected by several factors. See [Appendix B](#).**

- 1** Press the **MENU** key.
- 2** Press the  $\wedge$  or  $\vee$  key repeatedly until `Others >` appears.
 

```
Others >
```
- 3** Press the `>` key.
- 4** Press the  $\wedge$  or  $\vee$  key repeatedly until `>Resource Prot.` appears.
 

```
>Resource Prot.
  Off
```
- 5** Press the **ENTER** key. A blinking question mark (?) appears.
 

```
>Resource Prot.
? Off
```
- 6** Press the  $\wedge$  or  $\vee$  key to display the desired mode. The display changes as shown below.
 

```
Off (default)
Permanent
Perm / Temp
```
- 7** When the desired mode is displayed, press the **ENTER** key.
- 8** Press the **MENU** key. The message display returns to `Ready`.

## Alarm (Buzzer) Setting

In addition to the message displayed when the paper supply is exhausted, or when paper jamming occurs, an audio warning is made to sound. This is useful, for example, when the printer is in a location some distance from the user.

The audio alarm is set to **On** when leaving the factory. If the alarm is set to **Off**, it is made not to sound.

- 1 Press the **MENU** key.
- 2 Press the **^** or **∨** key repeatedly until **Others >** appears.

```
Others >
```

- 3 Press the **>** key.
- 4 Press the **^** or **∨** key repeatedly until **Buzzer** appears.

```
>Buzzer  
On
```

- 5 Press the **ENTER** key. A blinking question mark (?) appears.

```
>Buzzer  
? On
```

- 6 Select **On** or **Off** using the **^** or **∨** key.
- 7 Press the **ENTER** key.
- 8 Press the **MENU** key. The message display returns to **Ready**.

## Auto Continue Setting

If an error that still allows you to continue printing occurs (Memory overflow Press GO, Print overrun Press GO, KPDL error Press GO, and File not found Press GO), the next received data is automatically printed after a set period of time elapses. For example, if the printer is shared over a network as a network printer and one person causes one of the above errors, after the set period of time elapses, the data sent from the next person is printed.

- 1 Press the **MENU** key.
- 2 Press the  $\wedge$  or  $\vee$  key repeatedly until Others > appears.

```
Others >
```

- 3 Press the > key.
- 4 Press the  $\wedge$  or  $\vee$  key repeatedly until Auto Continue > appears.

```
>Auto Continue >  
Mode On
```

- 5 Press the **ENTER** key. A blinking question mark (?) appears.

```
>Auto Continue  
Mode ? On
```

- 6 Select On or Off using the  $\wedge$  or  $\vee$  key.
- 7 Press the **ENTER** key.
- 8 Press the **MENU** key. The message display returns to Ready.

### Setting the Auto Continue Recovery Time

Follow the procedure given below to change the recovery time for Auto Continue.

**1** Press the **MENU** key.

**2** Press the **^** or **∨** key repeatedly until `Others >` appears.

```
Others >
```

**3** Press the **>** key.

**4** Press the **^** or **∨** key repeatedly until `>Auto Continue Mode >` appears.

```
>Auto Continue >
Mode On
```

**5** Press the **>** key and display `>>Auto Continue Timer.`

**6** Press the **ENTER** key. A blinking cursor ( `_` ) appears.

```
>>Auto Continue
Timer 000Sec.
```

**7** Press the **^** or **∨** key to increase or decrease the value of the figure where the cursor is blinking and set the desired time. The time must be set between 000 and 495 seconds, in 5-second increments. If set to 000, printing will be continued immediately without allowing any time interval. You can use the **>** and **<** keys to move the cursor right and left.

**8** Display the desired time and press the **ENTER** key.

**9** Press the **MENU** key. The message display returns to `Ready.`



---

## Chapter 2      **Paper Selection**

---

This chapter explains the following topics:

- **General Guidelines**
- **Special Paper**
- **Paper Type**

## General Guidelines

The printer is designed to print on high-quality copier bond paper (the kind used in ordinary dry copier machines), but it can also accept a variety of other types of paper within the limits specified below.



Note

**The manufacturer assumes no liability for problems that occur when paper not satisfying these requirements is used.**

Selection of the right paper is important. Using the wrong paper can result in paper jams, misfeeding, curling, poor print quality, and paper waste, and in extreme cases can damage the printer. The guidelines given below will increase the productivity of your office by ensuring efficient, trouble-free printing and reducing wear and tear on the printer.

### Paper Availability

Most types of paper are compatible with a variety of machines. Paper intended for xerographic copiers can also be used with the printer.

There are three general grades of paper: economy, standard, and premium. The most significant difference between grades is the ease with which they pass through the printer. This is affected by the smoothness, size, and moisture content of the paper, and the way in which the paper is cut. The higher the grade of paper you use, the less risk there will be of paper jams and other problems, and the higher the level of quality your printed output will reflect.

Differences between paper from different suppliers can also affect the printer's performance. A high-quality printer cannot produce high-quality results when the wrong paper is used. Low-priced paper is not economical in the long run if it causes printing problems.

Paper in each grade is available in a range of basis weights (defined later). The traditional standard weights are 16, 20, and 28 pounds (60 to 105 g/m<sup>2</sup>).

### Paper Specifications

The following table summarizes the basic paper specifications. Details are given on the following pages.

Item	Specification
Weight	Cassette: 60 to 105 g/m <sup>2</sup> (16 to 28 lb/ream) MP tray: 60 to 200 g/m <sup>2</sup> (16 to 53 lb/ream)
Thickness	0.086 to 0.110 mm (3.4 to 4.3 mils)
Dimensional accuracy	±0.7 mm (±0.0276 inches)
Squareness of corners	90° ±0.2°
Moisture content	4 to 6 %
Direction of grain	Long grain
Pulp content	80 % or more

## Selecting the Right Paper

Laser printing is a process involving laser light, electrostatic discharge, toner, and heat. In addition, as the paper passes through the printer it undergoes considerable sliding, bending, and twisting motions. A high-quality printing paper matching the printer's requirements withstands all these stresses, enabling the printer to turn out clean, crisp printed copies consistently.

Remember that all paper is not the same. Some of the factors to consider when selecting paper for the printer are as follows:

### Condition of the Paper

Avoid using paper that is bent at the edges, curled, dirty, torn, embossed, or contaminated with lint, clay, or paper shreds.

Use of paper in these conditions can lead to illegible printing, misfeeding, and paper jams, and can shorten the life of the printer. In particular, avoid using paper with a surface coating or other surface treatment. The paper should have as smooth and even a surface as possible.

### Composition

Do not use paper that has been coated or surface-treated and contains plastic or carbon. The heat of fusing can cause such paper to give off harmful fumes.

Bond paper should contain at least 80 % pulp. Not more than 20 % of the total paper content should consist of cotton or other fibers.

### Paper Size

Cassettes and an MP tray are available for the paper sizes listed in the table below. The dimensional tolerances are  $\pm 0.7$  mm ( $\pm 0.0276$  inches) for the length and width. The angle at the corners must be  $90^\circ \pm 0.2^\circ$ .

Multi-purpose tray	Size	Cassette or multi-purpose tray	Size
Monarch	3-7/8 × 7-1/2 inches	Legal	8-1/2 × 14 inches
Business	4-1/8 × 9-1/2 inches	Letter	8-1/2 × 11 inches
ISO A6	105 × 148 mm	ISO A4	210 × 297 mm
ISO DL	11 × 22 cm	ISO A5	148 × 210 mm
ISO C5	16.2 × 22.9 cm	JIS B5	182 × 257 mm
ISO B5	17.6 × 25 cm	Custom	Cassette: 148 to 216 mm × 210 to 297 mm For U. S. A.: 5-13/16 to 8-1/2 inches × 8-1/4 to 14 inches  MP tray: 70 to 216 mm × 148 to 297 mm (2-13/16 to 8-1/2 inches × 5-13/16 to 11-11/16 inches)
Executive	7-1/4 × 11/2 inches		
Commercial 9	3-7/8 × 8-7/8 inches		
Commercial 6-3/4	3-5/8 × 6-1/2 inches		
JIS B6	128 × 182 mm		
Oficio II	8-1/2 × 13 inches		
Statement	5-1/2 × 8-1/2 inches		
Folio	210 × 330 mm		
Hagaki	100 × 148 mm		
Ofuku-Hagaki	148 × 200 mm		
Youkei 2	114 × 162 mm		
Youkei 4	105 × 235 mm		

### Smoothness

The paper should have a smooth, uncoated surface. Paper with a rough or sandy surface can cause voids in the printed output. Paper that is too smooth, however, can cause multiple feeding and fogging problems. (Fogging is a gray background effect.)

### Basis Weight

Basis weight is the weight of a standard quantity of paper. In the traditional system, the standard quantity is a ream consisting of 500 sheets measuring 17 × 22 inches each. In the metric system the standard quantity is 1 square meter.

Paper that is too light or too heavy can cause misfeeding, jams, and premature wear of the printer. Uneven paper weight can cause multiple feeds, print defects, poor toner fusing, blurring, and other print quality problems. The proper weight is 60 to 105 g/m<sup>2</sup> for the paper cassette, and 60 to 200 g/m<sup>2</sup> for the MP tray.

### Paper Weight Equivalence Table

Paper weight is listed with expression in U.S. bond weight (lb) and European metric ( $\text{g/m}^2$ ). The shaded point indicates the standard weight.

<b>U. S. Bond Weight (lb)</b>	16	17	20	21	22	24	27	28	32	34	36	39	42	43	47	53
<b>Europe Metric Weight (<math>\text{g/m}^2</math>)</b>	60	64	75	80	81	90	100	105	120	128	135	148	157	163	176	199

### Thickness (Caliper)

Thick paper is referred to as high-caliper paper and thin paper as low-caliper paper. The paper used with the printer should be neither extremely thick nor extremely thin. If you are having problems with paper jams, multiple feeds, and faint printing, the paper you are using may be too thin. If you are having problems with paper jams and blurred printing, the paper may be too thick. The proper thickness is 0.086 to 0.110 mm (3.4 to 4.3 mils).

### Moisture Content

Moisture content is defined as the percent ratio of moisture to the dry mass of the paper. Moisture can affect the paper's appearance, feedability, curl, electrostatic properties, and toner fusing characteristics.

The moisture content of the paper varies with the relative humidity in the room. When the relative humidity is high and the paper absorbs moisture, the paper edges expand, becoming wavy in appearance. When the relative humidity is low and the paper loses moisture, the edges shrink and tighten, and print contrast may suffer.

Wavy or tight edges can cause misfeeding and alignment anomalies. The moisture content of the paper should be 4 to 6%.

To ensure the proper moisture content, it is important to store the paper in a controlled environment. Some tips on moisture control are:

- Store paper in a cool, dry location.
- Keep the paper in its wrapping as long as possible. Rewrap paper that is not in use.
- Store paper in its original carton. Place a pallet, etc., under the carton to separate it from the floor.
- After removing paper from storage, let it stand in the same room as the printer for 48 hours before use.
- Avoid leaving paper where it is exposed to heat, sunlight, or damp.

### Paper Grain

When paper is manufactured, it is cut into sheets with the grain running parallel to the length (long grain) or parallel to the width (short grain). Short grain paper can cause feeding problems in the printer. All paper used in the printer should be long grain.

### Other Paper Properties

**Porosity:** Refers to the density of the paper structure; that is, how openly or compactly the fibers are bonded.

**Stiffness:** Limp paper can buckle inside the printer, while paper that is too stiff may bind. Either way the result is a paper jam.

**Curl:** Most paper has a natural tendency to curl in one direction. The paper should be loaded so that the natural curl is downward, to counteract the upward curl imparted by the printer. Printed sheets will then come out flat. Most paper also has a top and bottom surface. Loading instructions are usually given on the paper package.



**If the paper is considerably curled in one direction, e.g. when the paper was used to print on one side, try to roll the paper in the opposite direction to counteract the curl. Printed sheets will then come out flat.**

**Electrostatic properties:** During the printing process, the paper is electrostatically charged to attract the toner. The paper must be able to release this charge so that printed sheets do not cling together in the output tray.

**Whiteness:** The contrast of the printed page depends on the whiteness of the paper. Whiter paper provides a sharper, brighter appearance.

**Quality control:** Uneven sheet size, corners that are not square, ragged edges, welded (uncut) sheets, and crushed edges and corners can cause the printer to malfunction in various ways. A quality paper supplier should take considerable care to ensure that these problems do not occur.

**Packaging:** Paper should be packed in a sturdy carton to protect it from damage during transport. Quality paper obtained from a reputable supplier is usually properly packaged.

## Special Paper

This section explains printing on special paper. The page printer can use the following types of special paper. In this case, set the media type according to the table below.

Paper type	Media type
Colored paper	Color
Preprinted paper	Preprinted
Overhead projector transparencies	Transparency
Postcards	Cardstock
Envelopes	Envelope
Labels	Labels

When using the above types of paper, be sure to use products that are specified for use with photocopiers and/or page printers. Feed paper other than colored paper or pre-printed paper from the MP (multi-purpose) tray.

Use paper that is sold specifically for use with copiers (heat-fusing type). Label paper and envelopes should not be placed in the cassette; they must be fed manually and delivered in the face up stack.

Since the composition and quality of special paper vary considerably, special paper is more likely than white bond paper to give trouble during printing. No liability will be assumed if moisture, etc., given off in printing on special paper causes harm to the machine or operator.



Note

**Before purchasing any type of special paper, test a sample on the printer and check that print quality is satisfactory.**

Specifications for each type of special paper are given below.

### Transparency (Overhead Projection Film)

Transparency must be able to withstand the heat of fusing during the printing process. It should satisfy the conditions given in the table below.

Item	Specification
Tolerance of heat	Must tolerate at least 190 °C (374 °F)
Thickness	0.100 to 0.110 mm (3.9 to 4.3 mils)
Material	Polyester
Dimensional accuracy	±0.7 mm (±0.0276 inch)
Squareness of corners	90° ± 0.2°

To avoid trouble, transparency must be delivered face-up.

If transparency jams frequently, pull the top of the sheet very gently as it leaves the printer.

## Adhesive-Backed Labels

The basic rule for printing on adhesive labels is that the adhesive must never come into contact with any part of the printer. Adhesive paper sticking to the drum or rollers will damage the printer.



Note

**Be sure to feed label paper from the MP tray. Feeding label paper from a paper cassette may cause printer failure.**

Label paper has a structure comprised of three layers, as shown in the figure below. The top sheet is printed on. The adhesive layer consists of pressure-sensitive adhesives. The carrier sheet (also called the linear or backing sheet) holds the labels until use. Due to the complexity of its composition, adhesive-backed label paper is particularly likely to give trouble in printing.

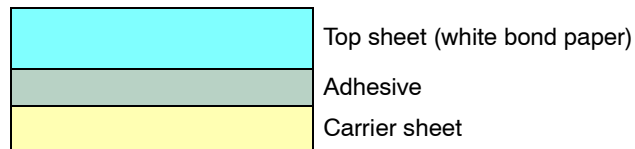

Adhesive label paper must be entirely covered by its top sheet, with no spaces between the individual labels. Labels with spaces in between are apt to peel off, causing serious paper jam problems.

Some label paper is manufactured with an extra margin of top sheet around the edge. Do not remove the extra top sheet from the carrier sheet until after printing is finished.

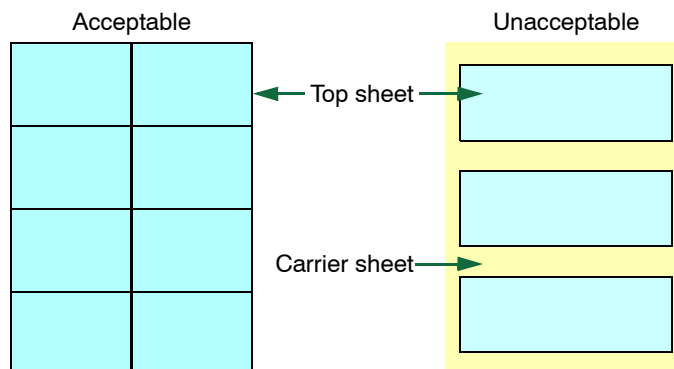



The table below lists the specifications for adhesive label paper.

Item	Specification
Weight of top sheet	44 to 74 g/m <sup>2</sup> (12 to 20 lb/ream)
Composite weight	104 to 151 g/m <sup>2</sup> (28 to 40 lb/ream)
Thickness of top sheet	0.086 to 0.107 mm (3.9 to 4.2 mils)
Composite thickness	0.115 to 0.145 mm (4.5 to 5.7 mils)
Moisture content	4 to 6 % (composite)

### Envelopes

The printer can print on envelopes using paper with a basis weight of 60 to 79 g/m<sup>2</sup> (16 to 21 lb/ream). Envelopes must be manually fed.

An envelope is a more complex object than a single sheet of paper. For this reason, it may not be possible to obtain consistent print quality over the entire envelope surface.

Many envelopes have a diagonal grain orientation (See [Paper Grain](#) on page 2-6). This orientation is more likely to wrinkle and crease on its way through the printer. Before purchasing envelopes for use with the printer, test a sample to verify the envelope's suitability.

Do not use envelopes that have an encapsulated liquid adhesive.

Avoid long printing runs consisting of envelopes only. Extensive envelope printing can cause premature printer wear.

To avoid jamming due to curled envelopes, do not leave more than approximately 10 printed envelopes stacked in the paper trays during multiple envelope printing.

### Colored Paper

Colored paper should satisfy the same conditions as white bond paper, listed in [Paper Specifications](#) on page 2-2. In addition, the pigments used in the paper must be able to withstand the heat of fusing during the printing process (up to 200 °C or 392 °F).

### Preprinted Paper

Preprinted paper should have a bond paper base. The preprinted ink must be able to withstand the heat of fusing during the printing process, and must not be affected by silicone oil.

Do not use paper with any kind of surface treatment, such as the type of paper commonly used for calendars.

### **Recycled Paper**

Select recycled paper that meets the same specifications as the white bond paper (see *Paper Specifications* on page **2-2**) except whiteness.



Note

**Before purchasing recycled paper, test a sample on the printer and check that the print quality is satisfactory.**

## Paper Type

The printer is capable of printing under the optimum setting for the type of paper being used.

Setting the paper type for the paper source from the printer's operator panel will cause the printer to automatically select the paper source and print in the mode best suited to that type of paper.

A different paper type setting can be made for each paper source including the MP tray. Not only can preset paper types be selected, but it is also possible for you to define and select customized paper types. See [Custom Paper Type](#) on page 1-32.

The following types of paper can be set.

Paper source Paper Type	MP tray	Paper Cassette	Paper Weight	Duplex path (MP tray available only in Cassette mode)
Plain	Yes	Yes	Normal	Yes
Transparency	Yes	No	Heavy (Thick)	No
Preprinted	Yes	Yes	Normal	Yes
Labels	Yes	No	Normal	No
Bond	Yes	Yes	Normal	Yes
Recycled	Yes	Yes	Normal	Yes
Vellum	Yes	No	Light (Thin)	No
Rough	Yes	Yes	Normal	Yes
Letterhead	Yes	Yes	Normal	Yes
Color	Yes	Yes	Normal	Yes
Prepunched	Yes	Yes	Normal	Yes
Envelope	Yes	No	Normal	No
Cardstock	Yes	No	Heavy (Thick)	No
Custom 1 (to 8)*	Yes	Yes	Normal	Yes

Yes: Can be stored No: Cannot be stored

\* This is a paper type defined and registered by the user. Up to eight types of user settings may be defined. For details on [Custom Paper Type](#) on page 1-32.

---

## Chapter 3      **Maintenance**

---

This chapter explains how to replace the toner container and how to clean parts such as the registration roller and charger wire.

This chapter explains the following topics:

- **Toner Container Replacement**
- **Waste Toner Box Replacement**
- **Cleaning**

## Toner Container Replacement

The toner container in the printer should be replaced as soon as the message display shows `Toner low TK-50` or soon after. If you continue to use the printer, eventually the toner supply will be exhausted at which point the printer will stop printing and the `Replace toner Clean printer` message will be shown instructing you to install a new toner kit.

### Toner Container Replacement Interval

Assuming an average toner coverage of 5% and Ecoprint mode turned off, the toner container will need replacing approximately once every 10,000 pages.\*

- \* For a new printer with a toner kit installed for the first time, the number of copies that can be printed will be approximately 5,000.

#### Toner Kits to be Used

Name: TK-50 (10,000 pages)  
Contents: Toner container  
Waste toner box  
Wiper cloth  
Grid cleaner  
2 plastic bags (for disposal of the old toner container and waste toner box)  
Installation Guide



Note

- **Be sure to distance items such as floppy disks during toner container replacement.**
- **Be sure to clean the inside of the printer when replacing the toner container. For details, see [Cleaning](#) on page 3-9.**
- **Use of original Kyocera Mita toner kits is highly recommended to prevent printer trouble and ensure the long life of the printer.**

## Replenishing Toner

- 1 Open the printer top cover all the way.

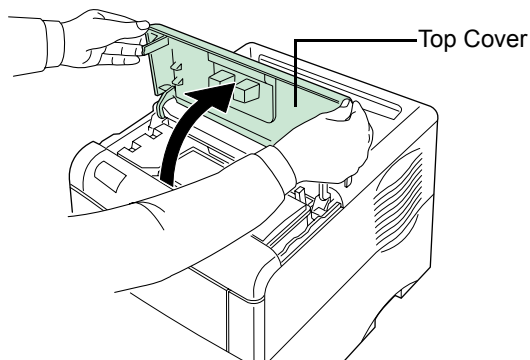

- 2 Pull the lock lever (green colored) to the right and gently lift the old toner container.

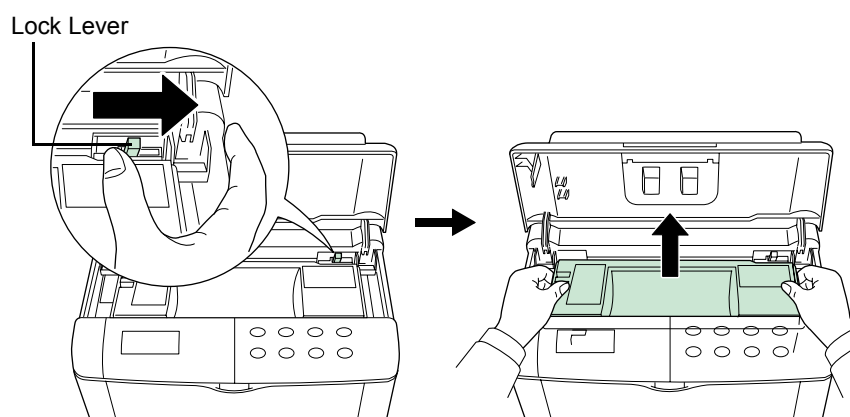

Note

- Keep the toner container as level as possible while removing.

- 3 Put the old toner container in the plastic bag supplied with the toner kit and dispose of it.

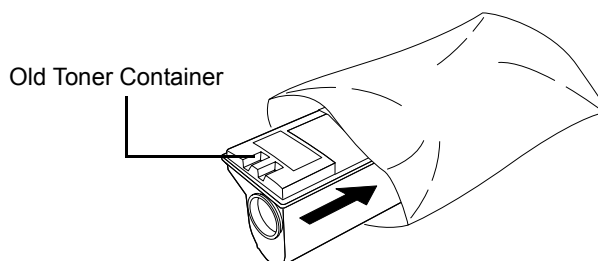

Note

- The old toner container may be incinerated without the risk of generating harmful gas.

**4** Take the new toner container from the bag.

**5** With the label side down, thoroughly shake the toner container (in the direction of the arrows) ten times or more. This ensures that the toner is evenly distributed inside.

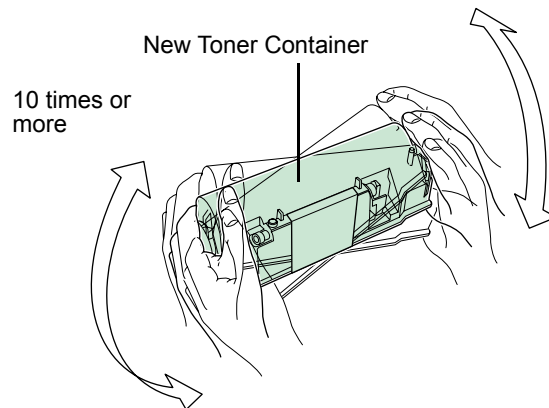

**6** Carefully remove the protective seal (orange colored).

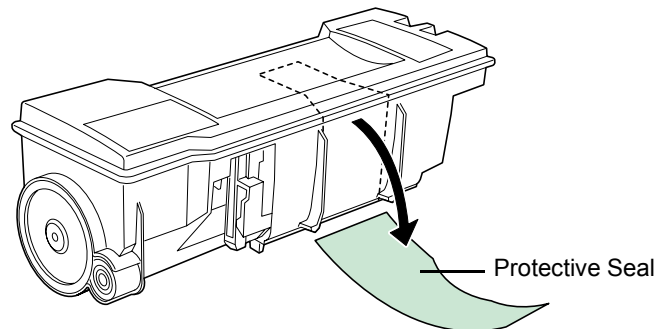

**7** Install the toner container into the printer.

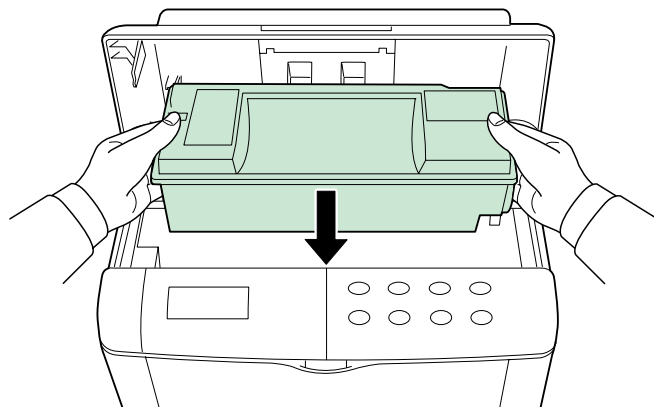

- 8** Push firmly on the top of the toner container at the positions marked **PUSH HERE**.

When the toner container fits into place, it will lock with a clicking sound.

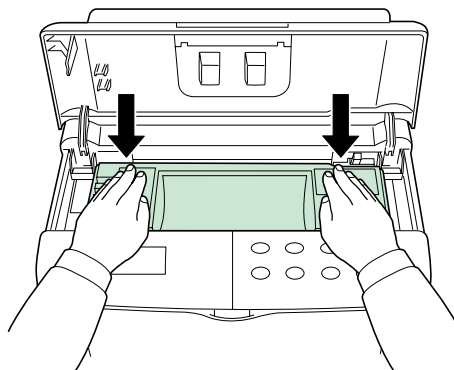

- 9** Close the top cover.

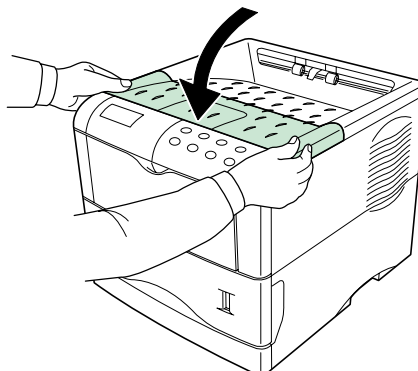

Note

It is necessary to clean the inside of the printer after replacing the toner container. If the toner container is replaced when **Replace toner Clean printer** is displayed, **Clean printer Press GO** will appear after replacement. After cleaning the inside of the printer (see [Cleaning](#) on page 3-9), the message will disappear when the GO key is pressed, and the printer will be ready for printing.



## Waste Toner Box Replacement

### Replacing the Waste Toner Box



Note

When replacing the toner container, the used waste toner box in the printer should also be replaced with the new one from the new toner kit.

- 1 Open the left cover on the left side of the printer.

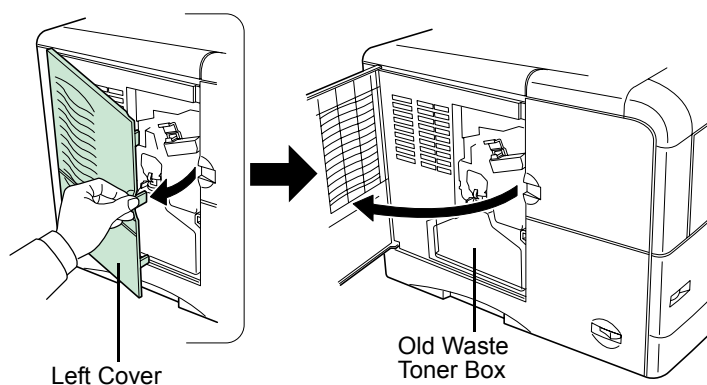

- 2 While holding the waste toner box, press the lock lever and then gently remove the waste toner box.

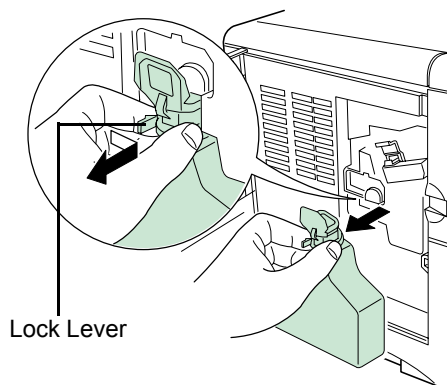

Note

Remove the waste toner box as gently as possible so as not to scatter the toner inside. Do not let the opening of the waste toner box face downward.

- 3** Cap the waste toner box after removing from the printer.

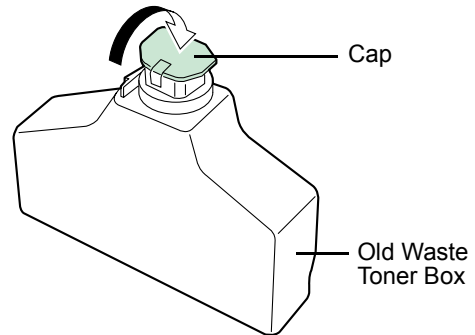

- 4** To avoid toner spilling, place the capped waste toner box in the plastic bag supplied before proper disposal.

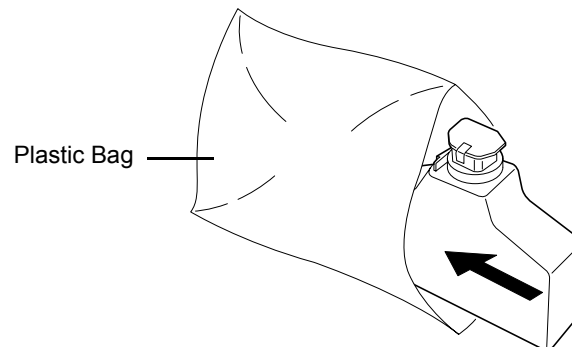

- 5** Open the cap of the new waste toner box.

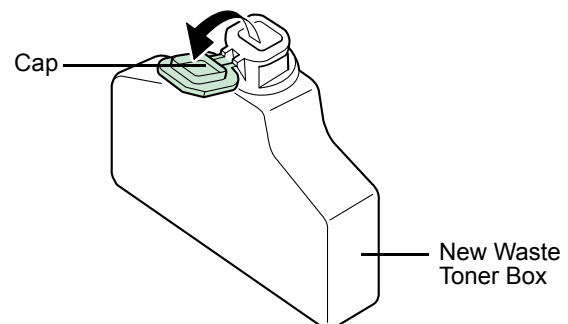

- 6** Insert the new waste toner box as shown in the figure below. The box will be locked when it fits into place.

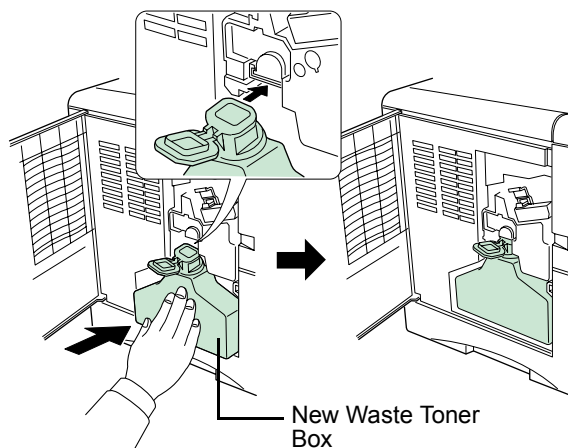

- 7** Ensure that it is correctly inserted and close the left cover.



The printer parts must be cleaned when replacing the toner container. See [Cleaning](#) on page [3-9](#).

- 8** When the toner container is replaced, reset the toner counter (see [Toner Counter Resetting](#) on page [1-96](#)).

## Cleaning

To avoid print quality problems, the following printer parts must be cleaned with every toner container replacement. In addition, the charger wire and paper transfer unit should be cleaned from time to time, or whenever print quality problems occur.



Note

If the toner container was replaced when **Replace toner Clean printer was displayed**, **Clean printer Press GO** will appear after replacement. After cleaning the inside of the printer following the procedure shown below, press the **GO** key; the message will disappear and the printer will be ready for printing.

### Cleaning the Charger Wire

The charger wire is a part in the drum unit that needs to be periodically cleaned. You can clean the charger wire by pulling the cleaning knob as instructed below.

- 1 Open the left cover on the left side of the printer.

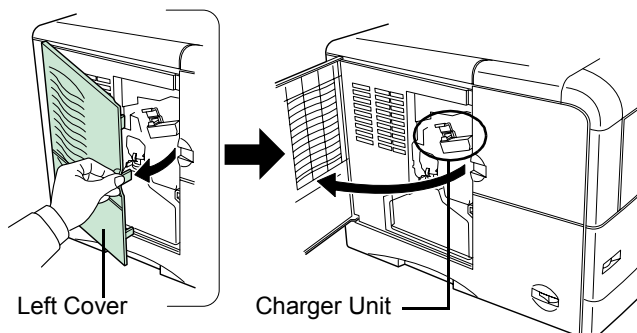

- 2 Pull the cleaning knob (green colored) slowly in and out a few times. This cleans charger wire inside the printer.

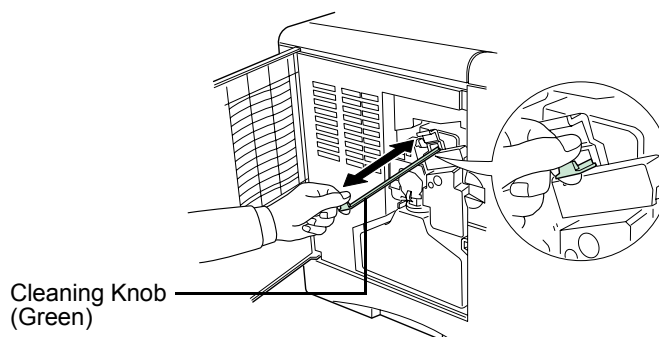

## Cleaning the Charger Grid

The charger grid is a part located at the bottom of the charger unit, which also needs to be cleaned. You should use a grid cleaner attaching it to the printer and pull out the charger unit as instructed below.

- 1 Take the grid cleaner from protective bag in the new toner kit, and remove the cap.

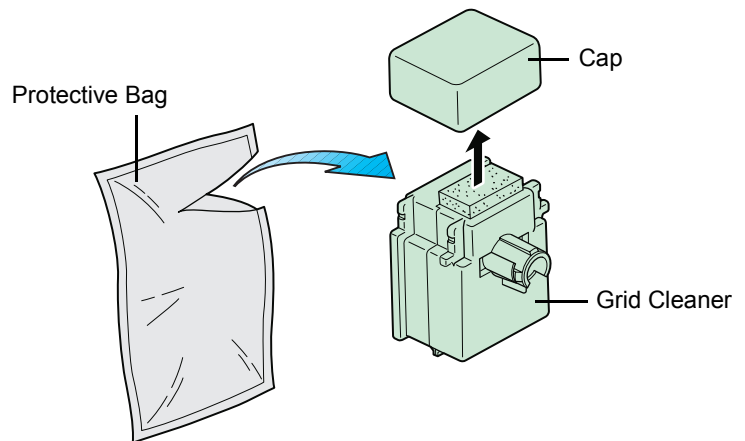

Note

The grid cleaner pad is supplied with water soaked. Perform the following procedure before the pad dries.

- 2 Attach the grid cleaner to the printer with the pad at the top, as shown in the figure.

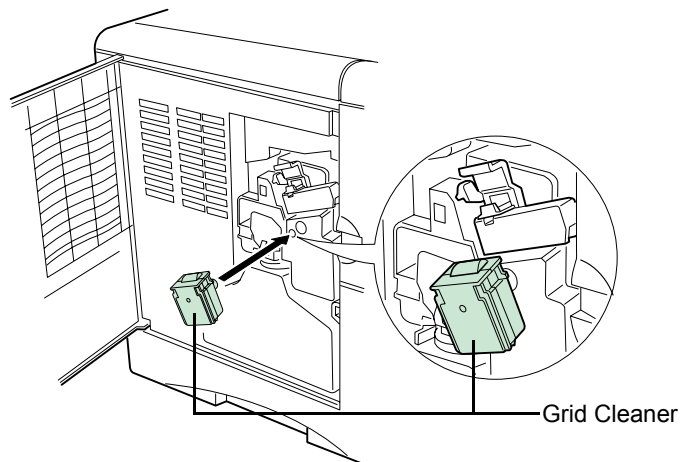

- 3** Slowly pull out and then push back in the charger unit at least 5 times. It is easier to pull out the charger unit for the first time if it is raised slightly, as shown in the figure.

This cleans grid part underneath the charger unit.

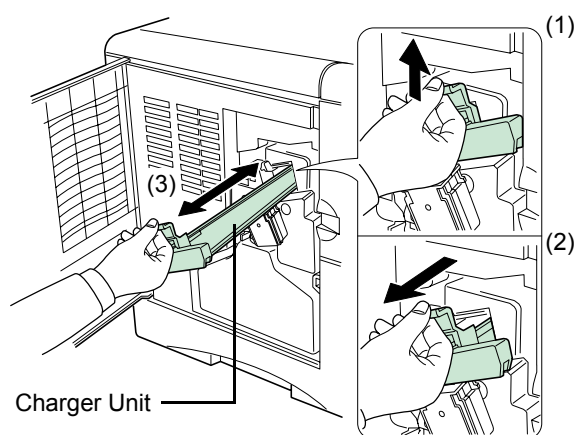

- 4** Remove the grid cleaner from the printer and dispose of it. The grid cleaner is not re-usable.

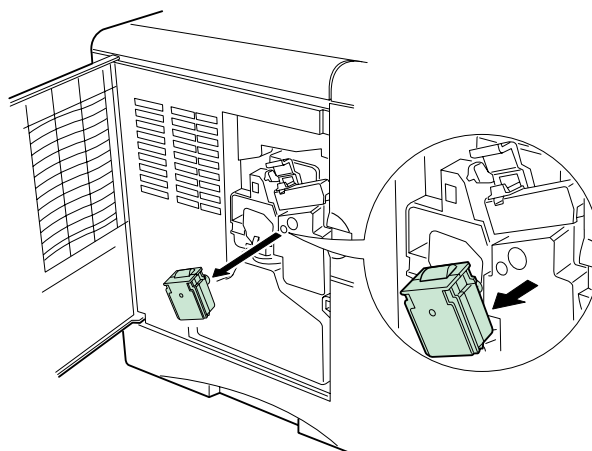

- 5 After cleaning the charger wire and grid, push the charger unit all the way in and close the left cover.



## Paper Transfer Unit

To avoid print quality problems due to paper dust and debris, clean the paper transfer unit in the following manner.

- 1 While pulling the paper transfer unit release lever (green colored), pull out the paper transfer unit.

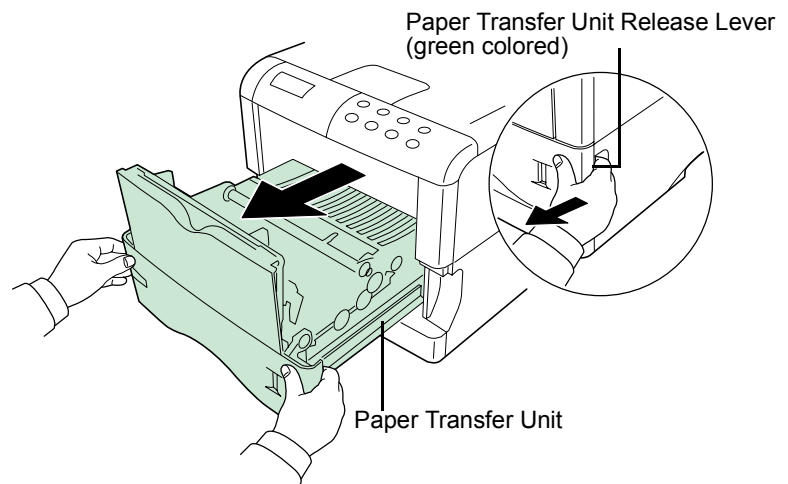

- 2 Wipe away the paper dust on the registration roller and the paper ramp using the wiper cloth included in the toner kit.

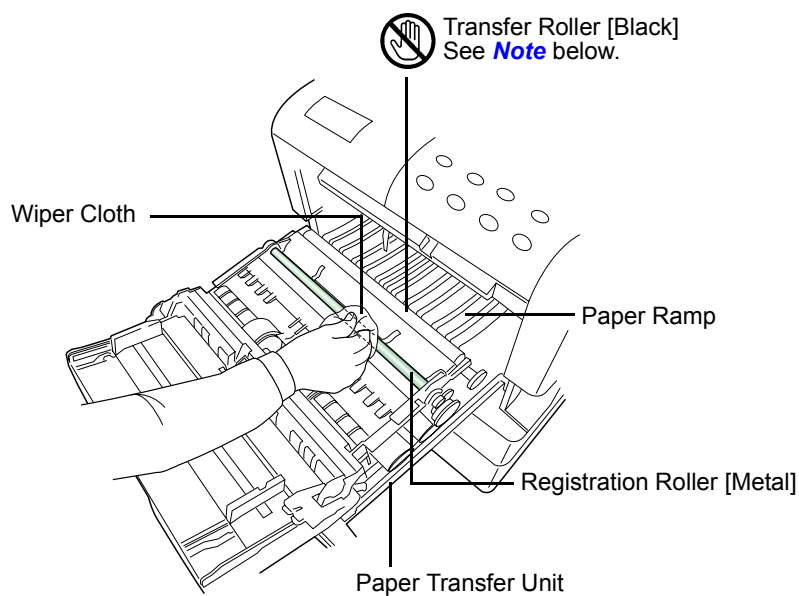

Note

**Be careful not to touch the transfer roller (the black roller) during cleaning as this may adversely affect print quality.**



---

## Chapter 4      **Troubleshooting**

---

This chapter explains how to handle printer problems that may occur. If a problem cannot be corrected, contact your Kyocera Mita dealer.

This chapter explains the following topics:

- **General Guide**
- **Print Quality Problems**
- **Indicators and Messages**
- **Correcting a Paper Jam**

## General Guide

There are quite a few printer problems that you can deal with by yourself. This section explains how to correct these problems. Therefore, if some kind of problem should occur, check the following before concluding the printer is broken.

Symptom	Check Items	Corrective Action	
The printer will not print from the computer.	Check the <b>READY</b>  indicator.	Off	Look through the items below and check anything that seems appropriate.
		Flashing	An error has occurred. For details on error warnings and remedies, see <i>Indicators</i> on page 4-6.
		Lit	See the appropriate item below.
	Check the <b>ATTENTION</b> indicator.	Flashing	See <i>Indicators</i> on page 4-6
		Lit	
A maintenance message appears in the message display.		See <i>Maintenance Messages</i> on page 4-7	
Print quality is not good.		See <i>Print Quality Problems</i> on page 4-3.	
Paper is jammed.		See <i>Correcting a Paper Jam</i> on page 4-12.	
Nothing lights on the operator panel even when power is turned on and the fan makes no noise.	Check that the power cord is properly plugged into the power outlet.	Turn off the printer's power, plug in the power cord securely, and try turning on the printer's power again.	
	Check that the power switch is really in the ON ( ) position.		
The printer prints a status page, but data from the computer is not being printed normally.	Check the interface cable.	Connect both ends of the interface cable securely. Try replacing the printer cable. For details on the parallel interface for this printer, see <i>Appendix C</i> .	
	Check program files and application software.	Try printing another file or using another print command. If the problem occurs only with a specific file or application, check the printer settings for that application.	

If you still cannot correct a printer problem even after checking the above, please contact your Kyocera Mita dealer.

## Print Quality Problems

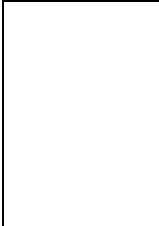
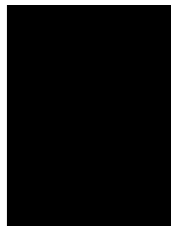
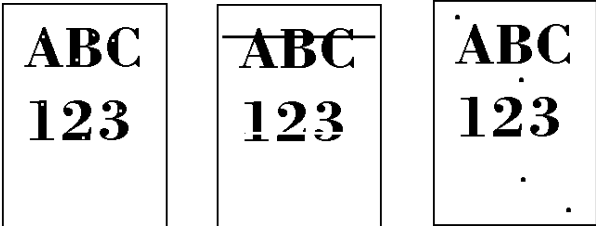

As the following table shows, there are many possible causes of print quality problems, such as blank output as. The troubleshooting procedure for each type of problem is explained below. If you still can not solve the problem, contact your Kyocera Mita dealer.

Printed Results	Corrective Action
<p>Completely blank printout</p> 	<p><b>Check the developer unit.</b> Open the printer top cover and check that the developer unit is inserted correctly and check that the developer's connector is connected properly.</p> <p><b>Check the toner container.</b> Open the printer top cover and check that the toner container is correctly installed in the printer. See <a href="#">Toner Container Replacement</a> on page 3-2.</p>
<p>All-black printout</p> 	<p><b>Check the charger unit.</b> Open the printer left cover and check that the charger unit is correctly installed.</p>
<p>Dropouts, horizontal streaks, stray dots</p> 	<p><b>Clean the charger wire.</b> Open the printer left cover. Pull the cleaning knob (green colored) slowly in and out a few times. See <a href="#">Cleaning</a> on page 3-9.</p>

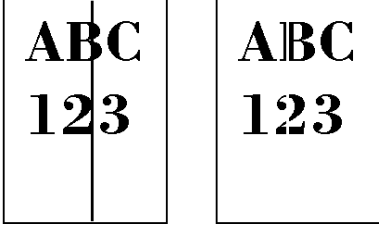
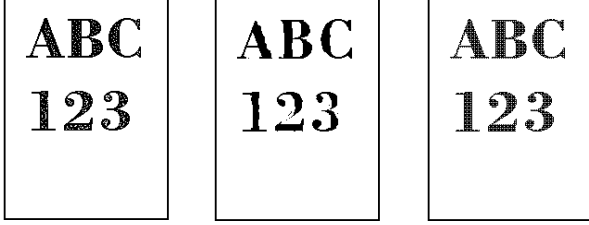
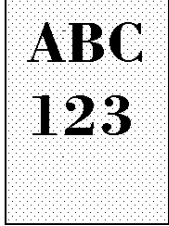
(Continued on next page)

Printed Results	Corrective Action
<p>Black or white vertical streaks</p> 	<p><b>Check the operator panel.</b> If the Toner low TK-50 message is displayed and the <b>ATTENTION</b> indicator is flashing, install a new toner kit. See <a href="#">Toner Container Replacement</a> on page 3-2.</p> <p><b>Clean the charger wire.</b> Open the printer left cover. Pull the cleaning knob (green colored) slowly in and out a few times. See <a href="#">Cleaning</a> on page 3-9.</p>
<p>Faint or blurred printing</p> 	<p><b>Check the Ecoprint setting.</b> When this setting is On, switch it to Off on the Operator Panel. (See <a href="#">Ecoprint</a> on page 1-54)</p> <p><b>Check the operator panel.</b></p> <ul style="list-style-type: none"> <li>• If the Toner low TK-50 message is displayed and the <b>ATTENTION</b> indicator is flashing, install a new toner kit. See <a href="#">Toner Container Replacement</a> on page 3-2.</li> <li>• Set the print density from the operator panel to a higher level than the current setting. See <a href="#">Print Density</a> on page 1-95.</li> <li>• Make sure the paper type setting is correct. See <a href="#">Paper Type</a> on page 2-11</li> </ul> <p><b>Clean the charger wire.</b> Open the printer left cover. Pull the cleaning knob (green colored) slowly in and out a few times. See <a href="#">Cleaning</a> on page 3-9</p>
<p>Grey background.</p> 	<p><b>Check the operator panel.</b> If the Toner low TK-50 message is displayed and the <b>ATTENTION</b> indicator is flashing, install a new toner kit. See <a href="#">Toner Container Replacement</a> on page 3-2.</p> <p><b>Check the print density.</b> Display the print density menu from the operator panel and select a lighter density setting. See <a href="#">Print Density</a> on page 1-95.</p> <p><b>Clean the charger wire.</b> Open the printer's left cover. Pull the cleaning knob (green colored) slowly in and out a few times. See <a href="#">Toner Container Replacement</a> on page 3-2.</p> <p><b>Check the charger unit installation.</b> Open the printer left cover and check that the charger unit is correctly installed and seated as far as it will go. See <a href="#">Cleaning</a> on page 3-9.</p>

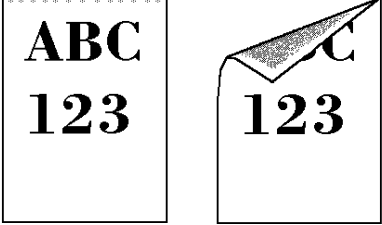





(Continued on next page)

Printed Results	Corrective Action
<p>Dirt on the top edge or back of the paper</p> 	<p><b>Check the paper chute and the ramp.</b>            Pull out the paper transfer unit and check for toner on the paper ramp. Clean the paper ramp using a soft, dry, lint-free cloth. See <a href="#">Cleaning</a> on page <a href="#">3-9</a>.</p> <p><b>Check the transfer roller.</b>            If the transfer roller is dirty with toner, try printing several pages.</p>
<p>Characters out of position.</p> 	<p><b>Check the file or program.</b>            Check whether the problem is being caused by a PRESCRIBE command error. If the problem occurs only with a specific file or program, the most likely cause is an error in a parameter to a command or command syntax.</p>

## Indicators and Messages

The tables on the following pages indicate how to respond to problems indicated by the operator panel indicators and messages.

### Indicators

Indicator	Name	Condition	Description
  READY	Ready indicator	Flashing	An error occurs that you can clear by yourself.
		Lit	The printer is on-line. The printer is ready to print.
		Off	The printer is off-line. The printer stores but does not print received data. Also indicates when printing is automatically stopped due to occurrence of an error.
  DATA	Data indicator	Flashing	Data transfer is taking place.
		Lit	Either data is being processed, or data is being written onto the option CompactFlash card or Microdrive.
  ATTENTION	Attention indicator	Flashing	The printer needs maintenance attention or the printer is warming up (Please wait).
		Lit	A problem or an error occurs that you can clear by yourself. (For example, a paper jam occurs.)
		Off	Operations are normal.



## Maintenance Messages

The following table lists maintenance messages that you can deal with by yourself. If Call service person appears, turn off the printer, disconnect the power cord, and contact your Kyocera Mita dealer.

Message	Corrective Action
Add paper (paper source)	The paper has run out. Supply paper according to the paper source displayed (paper cassette, MP tray, or optional paper feeder). Messages indicating the printer status (Ready, Please wait, Processing*, Waiting, and FormFeed Time Out*) are displayed alternately. * These messages will not appear if the number of copies is set to 2 or more.
Call service person F0	The <b>ATTENTION</b> indicator turns on and the <b>READY</b> indicator goes off. Indicates a problem with the controller and the operator panel. Call a service person. The printer does not operate when this message is displayed.
Call service ####	The <b>ATTENTION</b> indicator turns on. Indicates a controller error. Call a service person. The printer does not operate when this message is displayed.
Call service ####:0123456	The <b>ATTENTION</b> indicator turns on. Indicates a mechanical error. Call a service person. 0123456 indicates the number of printed pages.
Cassette # not loaded	The paper cassette may not be properly inserted into the printer. Reinsert the paper cassette. The paper source number (#) is only displayed when there is an option paper feeder installed.
Check waste toner box	The waste toner box is not installed. After installing the waste toner box, you should be able to print. Replace the old waste toner box with the new one which is included in the toner kit. The message will also be shown if the waste toner box has become full. The waste toner box should be replaced when the message display eventually shows Toner low TK-50. See <a href="#">Toner Container Replacement</a> on page 3-2.
Clean printer Press GO	Please clean the inside of the printer. See <a href="#">Cleaning</a> on page 3-9. This message will be displayed when replacing the toner container after the message Replace toner TK-50 is displayed. After cleaning the inside of the printer, press the <b>GO</b> key and the printer will be ready for printing. If Auto Continue is set to On, printing will be automatically resumed after a preset period of time.
Close duplexer rear cover	Open the option duplexer rear cover, then close tightly.
Close left cover	Open the left cover, then close tightly.
Close sorter rear cover	Open the sorter rear cover, then close tightly.
Close stacker cover	Open the stacker cover, then close tightly.
Close top cover	Open the top cover, then close tightly.
Close paper transfer unit	Open the paper transfer unit, then close tightly.
Face-down tray paper full	The face-down output tray has become full (approx. 250 pages). You must remove all printed pages from the face-down output tray. When the printer senses that the face-down output tray is empty again, it will continue printing into the face-down output tray.

 :Alarm buzzer sounds when an error occurs. Press the **CANCEL** key to stop the alarm buzzer.

(Continued on next page)

Message	Corrective Action
Load Cassette # (paper size)/(paper type)*  *(paper size) and (paper type) are displayed flashing alternately. 	There is data for printing that matches with a paper cassette setting (paper size, paper type), but there is no paper in the paper cassette. Set paper into the paper source as displayed on the operator panel, and press the <b>GO</b> key to restart printing. However, the paper source number (#) is only displayed when there is an option paper feeder installed.  Or, if you want to print from a different paper source press the ^ and v key to display Use alternative? and you can change the source for paper feeding.  After selecting a paper source and pressing the <b>MENU</b> key, Paper Handling > appears. By pressing the > key, the paper type settings menu appears. After setting the correct paper type, press the <b>ENTER</b> key and printing starts.
Load MP tray (paper size)/(paper type)  *(paper size) and (paper type) are displayed flashing alternately. 	There is no paper cassette set (paper size, paper type) that matches with the data for printing, so printing is done from the MP tray. Set paper into the MP tray that matches the paper size and type shown on the display and press the <b>GO</b> key to restart printing.  Or, if you want to print from a different paper source press the ^ and v key to display Use alternative? and you can change the source for paper feeding.  After selecting a paper source and pressing the <b>MENU</b> key, Paper Handling > appears. By pressing the > key, the paper type settings menu appears. After setting the correct paper type, press the <b>ENTER</b> key and printing starts.
Missing duplex drawer	The duplex drawer is either not installed or incorrectly inserted. Insert the duplex drawer securely.
Option interface Error	A failure has occurred with the option network interface card. Check the option interface installed in the printer.
Paper jam #####	Open the top cover or the paper transfer unit and correct the paper jam (or paper mis-feeding in the paper cassette). The location of the paper jam is also indicated in place of the #'s. Online help messages which are useful for correcting the paper jam will be displayed by pressing the ? key. (See <a href="#">Correcting a Paper Jam</a> on page 4-12)
Remove paper sorter tray ##	There is still paper in the option sorter's tray indicated by # when the power was turned on or the sorter's mode was switched. Remove all the paper inside the sorter.
Replace toner Clean printer	Replace the toner container using a new toner kit. The printer does not operate when this message is displayed. See <a href="#">Toner Container Replacement</a> on page 3-2.
Sorter tray ## paper full	The sorter tray indicated by # is now full. Remove some of the paper from the sorter tray concerned.
Toner low TK-50	Replace the toner container using a new toner kit. See <a href="#">Toner Container Replacement</a> on page 3-2.

 :Alarm buzzer sounds when an error occurs. Press the **CANCEL** key to stop the alarm buzzer.

(Continued on next page)



<b>Message</b>	<b>Corrective Action</b>
Unsupported external device	An unsupported option hardware has been installed. Be sure to install proper option hardware compatible with the FS-1900.
Warning image adapt	Printing job cannot be done in current resolution because there is not enough internal memory. Try adding more memory or changing resolution. See <a href="#">Appendix B</a> .
Warning low memory	The printer's internal memory is running low due to the number of fonts and macros downloaded. Print a status page to see how much user memory is left, and try deleting unnecessary fonts and macros. See <a href="#">Appendix B</a> .

## Error Messages

The following table lists error messages that can be dealt with by the user.

Message	Corrective Action
File not found Press GO	VMB: A VMB tray that was specified for output does not contain any jobs, or the VMB tray is not being used. Confirm the VMB tray. If Auto Continue is set to On, printing will be automatically resumed after a preset period of time. See <a href="#">Auto Continue Setting</a> on page <a href="#">1-105</a> .
Format error Memory card	This message appears when the printer is in the ready state and the CompactFlash (memory) card is not formatted, and therefore cannot be read or written. Follow the procedure in <a href="#">Formatting a Storage Device</a> on page <a href="#">1-88</a> to format the card.
Format error Hard disk	Initialization (formatting) of the Microdrive is required. Initialize the Microdrive. (See <a href="#">Operating the Storage Device</a> on page <a href="#">1-81</a> .)
Hard disk err ## Press GO	Look at the error code given in place of ## and refer to the corresponding description given below. 01: Microdrive format error. If this error recurs even if the power has been turned off and then on, reformat the Microdrive. 02: The disk system is not installed. Recheck the requirements for using the system and the devices. 04: There is no available Microdrive space. Delete unnecessary files, etc., in order to free up space. 05: The specified file does not exist in the Microdrive. 06: There is no memory available to the Microdrive system. Increase the available memory. 10: Formatting is not possible because host data is being spooled on the Microdrive. Wait until the Microdrive is ready, and then format. 85: VMB; Alias error (the alias setting was lost, or the VMB tray corresponding to the alias does not exist). Set the alias again. 97: Code job; The number of permanent code job reached the limit value, and no more can be saved. Either delete some unnecessary jobs, etc., or increase the limit. 99: A print job for the specified ID does not exist in the Microdrive.
I/F occupied	This message is displayed when you attempt to use the printer's operator panel to change the environmental settings on the interface from which data are presently being received.
ID error	The ID entered for a private job, or a stored job is not correct. Check the ID that is set using the printer driver.
Insert the same memory card	You have inserted the wrong CompactFlash (memory) card when the Insert again message was displayed. Remove the wrong CompactFlash card from the printer's CompactFlash card slot and insert the correct CompactFlash card. The printer again reads it from the beginning of the data.
KPDL error ## Press GO	Current print processing cannot continue. To print out an error report, display > Print KPDL errs from the mode select menu, and select On. Press the <b>GO</b> key to resume printing. You can abandon printing by the <b>CANCEL</b> key. If Auto Continue is set to On, printing will be automatically resumed after a preset period of time. See <a href="#">Auto Continue Setting</a> on page <a href="#">1-105</a> .

 :Alarm buzzer sounds when an error occurs. Press the **CANCEL** key to stop the alarm buzzer.

(Continued on next page)

Message	Corrective Action
Memory card err Insert again	The CompactFlash card is accidentally removed from the printer's memory card slot during reading. If you continue reading the memory card, insert the same memory card into the slot again. The printer again reads it from the beginning of the data. <b>Note: We recommend that you follow the reading procedure from the beginning to ensure correct reading of the memory card.</b>
Memory overflow Press GO	The total amount of data received by the printer exceeds the printer's internal memory. Try adding more memory (expansion DIMM). Press the <b>GO</b> key to resume printing. You can abandon printing by the <b>CANCEL</b> key. If Auto Continue is set to On, printing will be automatically resumed after a preset period of time. See <a href="#">Auto Continue Setting</a> on page <a href="#">1-105</a> .
MemoryCard err## Press GO	This message appears when an error occurs during access to the CompactFlash card using the PRESCRIBE RWER command or from the printer's operator panel. Look at the error code given in place of ## and refer to the corresponding description given below. 01: The CompactFlash card does not meet specifications. This CompactFlash card cannot be used by this printer. Insert a CompactFlash card which can be used by this printer. (See <a href="#">CompactFlash (Memory) Card</a> on page <a href="#">B-30</a> .) 02: The CompactFlash card is not installed. Recheck the requirements for using the CompactFlash card. 04: The capacity of the CompactFlash card is insufficient. Clean up files. 05: Specified file not on CompactFlash card. 06: No memory for use by CompactFlash card. Expand printer memory.
Paper path error	There is no paper cassette in the feeder, or the cassette is not inserted properly. After reinserting the paper cassette, you should be able to print. When two or more option feeders are installed and the lowest one is selected, the same message will appear if any of the upper paper feeder and the printer cassette is improperly installed.
Print overrun Press GO	The data transferred to the printer was too complex to print on a page. Press the <b>GO</b> key to resume printing. (The page may break in some pages.) You can abandon printing by the <b>CANCEL</b> key. <b>Note: After this message is displayed, page protect mode will be On. To maintain optimum use of memory during printing, display &gt;Page protect from the operator panel, and re-select Auto.</b> See <a href="#">Page Protect Mode</a> on page <a href="#">1-91</a> . If Auto Continue is set to On, printing will be automatically resumed after a preset period of time. See <a href="#">Auto Continue Setting</a> on page <a href="#">1-105</a> .
RAM disk error ## Press GO	Look at the error code given in place of ## and refer to the corresponding description given below. 01: Abnormal format. Try turning the power off and on again. 02: RAM disk mode is Off. Turn RAM disk mode On. 04: No disk space. Clean up files. 05: Specified file not on disk. 06: No memory for use by disk system. Expand printer memory.
Virtual mail box full	The storage area for the VMB is full. Print out accumulated VMB data.

 :Alarm buzzer sounds when an error occurs. Press the **CANCEL** key to stop the alarm buzzer.

## Correcting a Paper Jam

The Paper jam message is displayed on the message display when paper becomes stuck in the paper transport system, the paper feed timing is incorrect, or paper fails to feed at all. The jam can be corrected by removing the paper.

The printer goes off-line when the Paper jam message is displayed.

When a paper jam occurs, a paper jam message and the paper jam location are indicated on the message display. Details of the messages and paper jam locations are as follows:

Paper jam message	Paper jam location	Description	Reference page
Paper jam Cassette 1	<b>A</b>	Paper is jammed at the paper cassette or inside the printer.	<a href="#">4-14</a>
Paper jam Cassette 2 (to 4)	<b>B</b>	Paper is jammed at the option paper feeder's cassette.	<a href="#">4-14</a>
Paper jam Duplexer	<b>C</b>	Paper is jammed inside the rear cover of the option duplexer or at the duplexer drawer.	<a href="#">4-16</a>
Paper jam Sorter	<b>D</b>	Paper is jammed at the option sorter.	<a href="#">4-18</a>
Paper jam MP Tray	<b>E</b>	Paper is jammed at the MP tray.	<a href="#">4-20</a>

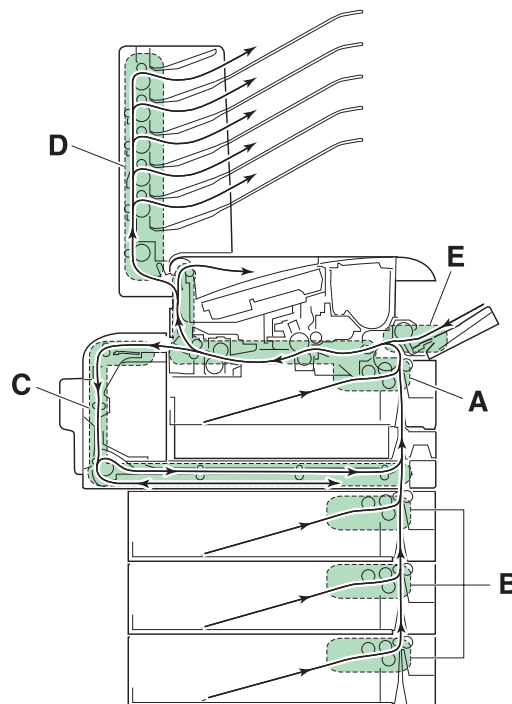

When the jammed paper has been removed, open and close the printer's top cover or the paper transfer unit. Then the printer automatically warms up, goes on-line, and continues printing. Depending on the point at which the jam occurred, the printer may or may not print the jammed page.

If paper jams occur frequently, try using a different type of paper, replace with paper from another ream, turn the stack of paper over, or turn the paper the other way around. Read the information in **Chapter 2**. Also, look for tiny pieces of paper that may have been torn off and overlooked when the jammed paper was removed.

If you cannot solve the problem by changing the paper, there may be a problem with the printer. Call a service person.



**When pulling the paper, pull it gently so as not to tear it. Torn pieces of paper are difficult to remove and may be easily overlooked, deterring the jam recovery.**

#### Online help messages

With the online help message function, this printer can display the procedure to correct a paper jam on the message display. When a paper jam message is displayed, press the **?** key. The display will show `Please wait` after the jammed paper has been removed.

Pressing the **∨** key at the online help message display shows the next step; pressing the **∧** key shows the previous step.

To exit the online help message display, press the **?** key. The previously shown paper jam message appears.

Online help messages that can be displayed when a paper jam occurs and their respective corrective actions are given below:

### Jam at the Paper Cassette or Inside the Printer

Paper jam  
Cassette 1



-- HELP START --  
Press **?** key

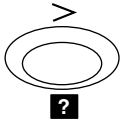

Paper is jammed at the paper cassette or inside the printer. Remove the jammed paper using the procedure given below.

While the display alternates between the paper jam message and HELP START, press the **?** key. An online help message appears.

Examples of online help messages

Open  
▼cassette 1 and



▲pull out paper  
▼transfer unit



▲then remove  
▼the paper jam.

**1** Pull out the paper cassette and remove the jammed paper.



**2** Push the paper cassette back in. While pulling the paper transfer unit release lever (green colored), pull out the paper transfer unit.

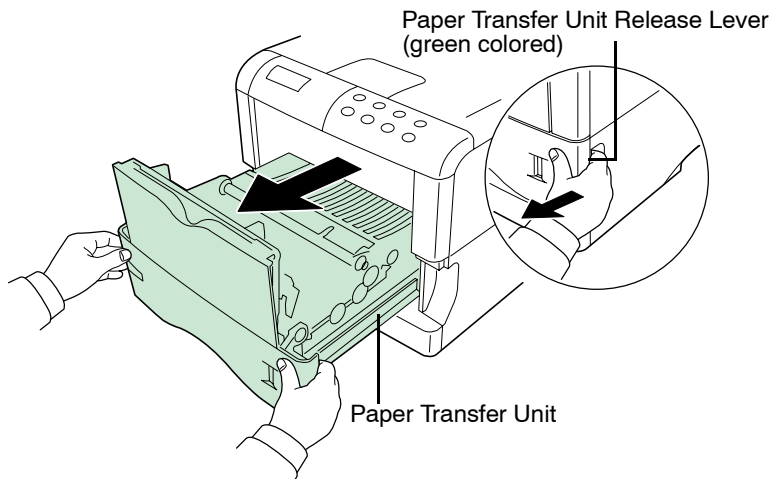

- 3** If paper is jammed before the registration roller, remove it as shown in **A**. If paper is jammed under the registration roller, remove it as shown in **B**.

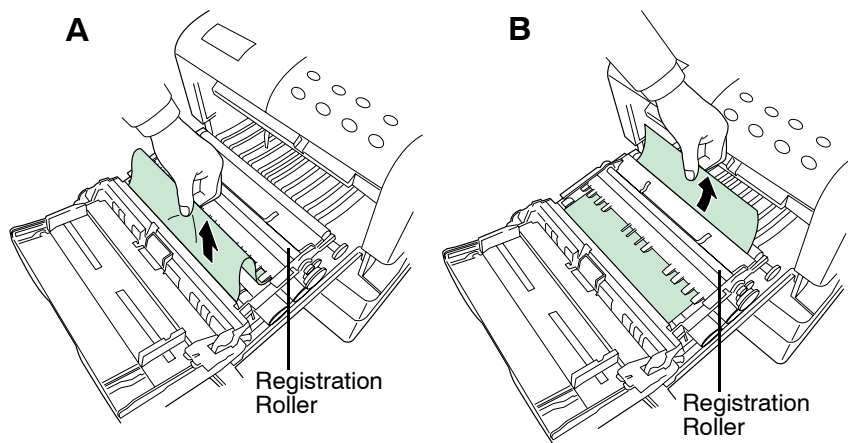

- 4** Open the rear cover and remove the jammed paper.

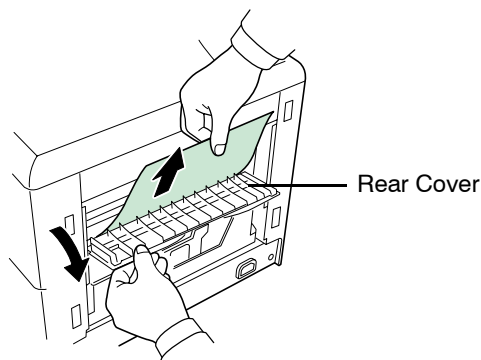
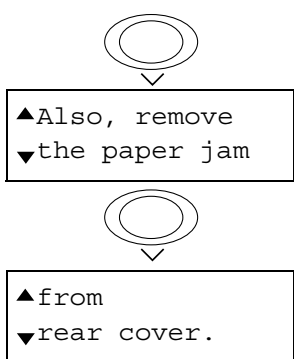

- 5** Push the paper cassette and paper transfer unit back in and close the rear cover.

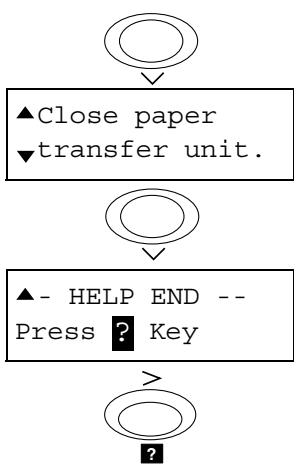

### Paper Jam at the Option Duplexer

Paper jam  
Duplexer



-- HELP START --  
Press **?** key

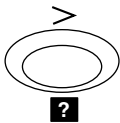

Paper is jammed inside the rear cover of the option duplexer or at the duplexer drawer. Remove the jammed paper using the procedure given below.

While the display alternates between the paper jam message and HELP START, press the **?** key. An online help message appears.

Examples of online help messages

Open duplexer  
▼rear cover and



▲remove  
▼the paper jam.

**1**

Open the rear cover of the duplexer and remove the jammed paper.

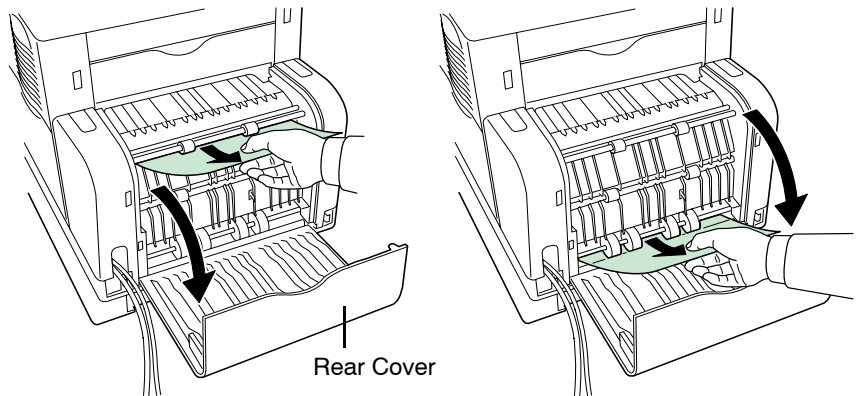

▲Pull out  
▼duplex drawer,

**2**

Pull out the duplex drawer.

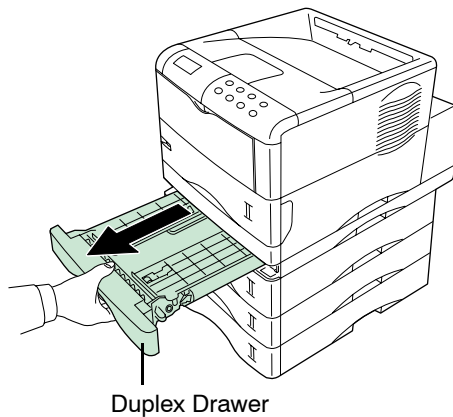



○  
▼  
▲and remove  
▼the paper jam.

**3** Remove the jammed paper.

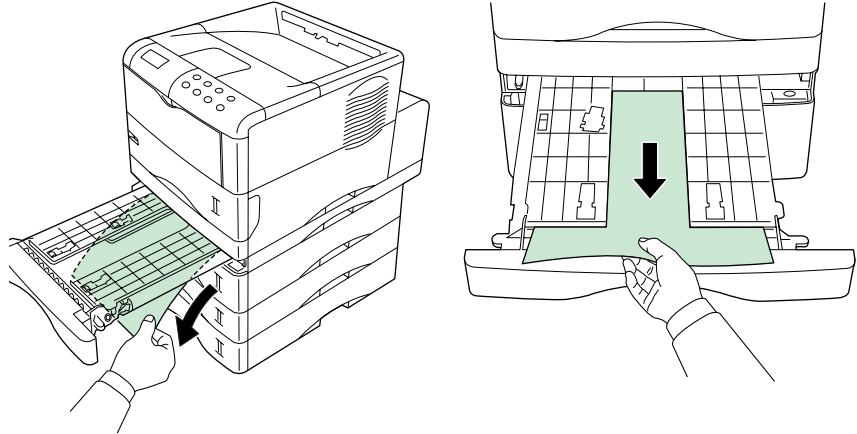

○  
▼  
▲Close  
▼rear cover

**4** Close the rear cover of the duplexer and the duplex drawer.

○  
▼  
▲and  
▼duplex drawer.

○  
▼  
▲- HELP END --  
Press **?** Key

○  
▼  
**?**

### Paper Jam at the Option Sorter

Paper jam  
Sorter



-- HELP START --  
Press **?** key

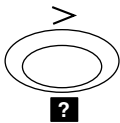

Paper is jammed at the option sorter. Remove the jammed paper using the procedure given below.

While the display alternates between the paper jam message and HELP START, press the **?** key. An online help message appears.

Examples of online help messages

Open sorter  
▼rear cover



▲and remove  
▼the paper jam

**1** Open the rear cover of the option sorter.

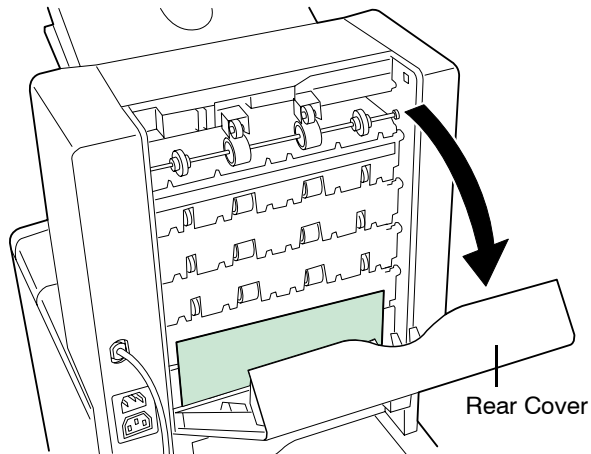

**2** Remove the jammed paper. If both ends of the paper are inside the sorter, turn the paper feed gears in the direction of the arrows. The paper can then be removed easily.

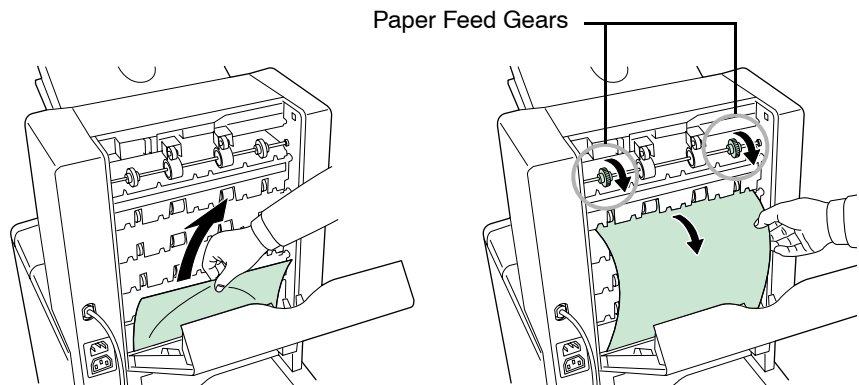

**3** Close the rear cover of the option sorter.

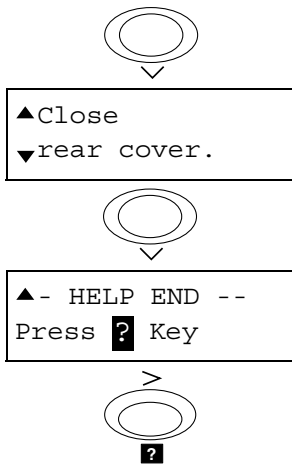

### Jam at the MP Tray

Paper jam  
MP tray



-- HELP START --  
Press **?** key

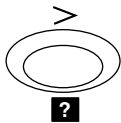

Paper is jammed at the MP tray. Remove the jammed paper using the procedure given below.

While the display alternates between the paper jam message and HELP START, press the **?** key. An online help message appears.

Examples of online help messages

Check the  
▼MP tray and



▲remove  
▼the paper jam.



▲Open and close  
▼top cover to



▲release paper  
▼jam error.



▲- HELP END --  
Press **?** Key



- 1 Remove the paper jammed at the MP tray.
- 2 Open and close the top cover (the paper jam error will be reset).

---

## Appendix A   **Fonts**

---

This appendix explains the types of fonts you can use with the printer. A font is a set of characters of a particular design. The design is referred to as a *typeface*. Several characteristics identify a font. These include the code set (For details on the code sets, read the *Programming Manual* on the supplied CD-ROM), spacing, pitch, height, style, stroke weight, and typeface family.

---

## List of Fonts

This section contains a full list of the printer's internal fonts. The printer has 80 PCL/PS compatible fonts and a bitmap font for a line printer. You can print the same font list from the printer by using the printer's operator panel key. To print a list of fonts, refer to **Font Lists** on page **1-21**.

Font may be downloaded to the printer's memory from a option Compact-Flash card or Microdrive.

### PCL (Scalable and Bitmap) Fonts

Font number	Font samples
0	This is a sample of Courier font.
1	This is a sample of CGTimes font.
2	<b>This is a sample of CGTimes-Bd font.</b>
3	<i>This is a sample of CGTimes-It font.</i>
4	<b><i>This is a sample of CGTimes-BdIt font.</i></b>
5	This is a sample of CGOmega font.
6	<b>This is a sample of CGOmega-Bd font.</b>
7	<i>This is a sample of CGOmega-It font.</i>
8	<b><i>This is a sample of CGOmega-BdIt font.</i></b>
9	<i>This is a sample of Coronet font.</i>
10	<b>This is a sample of Clarendon-Cd font.</b>
11	This is a sample of Univers-Md font.
12	<b>This is a sample of Univers-Bd font.</b>
13	<i>This is a sample of Univers-MdIt font.</i>
14	<b><i>This is a sample of Univers-BdIt font.</i></b>
15	This is a sample of Univers-MdCd font.
16	<b>This is a sample of Univers-BdCd font.</b>
17	<i>This is a sample of Univers-MdCdIt font.</i>
18	<b><i>This is a sample of Univers-BdCdIt font.</i></b>
19	This is a sample of AntiqueOlive font.
20	<b>This is a sample of AntiqueOlive-Bd font.</b>
21	<i>This is a sample of AntiqueOlive-It font.</i>
22	This is a sample of GaramondAntiqua font.
23	<b>This is a sample of Garamond-Hlb font.</b>
24	<i>This is a sample of Garamond-Krsv font.</i>
25	<b><i>This is a sample of Garamond-HlbKrsv font.</i></b>
26	<i>This is a sample of Marigold font.</i>
27	This is a sample of Albertus-Md font.

---

Font  
number    Font samples

---

- 28    **This is a sample of Albertus-ExBd font.**
- 29    This is a sample of Arial font.
- 30    **This is a sample of Arial-Bd font.**
- 31    *This is a sample of Arial-It font.*
- 32    ***This is a sample of Arial-BdIt font.***
- 33    This is a sample of TimesNewRoman font.
- 34    **This is a sample of TimesNewRoman-Bd font.**
- 35    *This is a sample of TimesNewRoman-It font.*
- 36    ***This is a sample of TimesNewRoman-BdIt font.***
- 37    This is a sample of Helvetica font.
- 38    **This is a sample of Helvetica-Bd font.**
- 39    *This is a sample of Helvetica-Ob font.*
- 40    ***This is a sample of Helvetica-BdOb font.***
- 41    This is a sample of Helvetica-Nr font.
- 42    **This is a sample of Helvetica-NrBd font.**
- 43    *This is a sample of Helvetica-NrOb font.*
- 44    ***This is a sample of Helvetica-NrBdOb font.***
- 45    This is a sample of Palatino font.
- 46    **This is a sample of Palatino-Bd font.**
- 47    *This is a sample of Palatino-It font.*
- 48    ***This is a sample of Palatino-BdIt font.***
- 49    This is a sample of ITCAvantGardeGothic-Bk font.
- 50    **This is a sample of ITCAvantGardeGothic-Dm font.**
- 51    *This is a sample of ITCAvantGardeGothic-BkOb font.*
- 52    ***This is a sample of ITCAvantGardeGothic-DmOb font.***
- 53    This is a sample of ITCBookman-Lt font.
- 54    **This is a sample of ITCBookman-Dm font.**
- 55    *This is a sample of ITCBookman-LtIt font.*
- 56    ***This is a sample of ITCBookman-DmIt font.***
- 57    This is a sample of NewCenturySchoolbook-Rom font.
- 58    **This is a sample of NewCenturySchoolbook-Bd font.**
- 59    *This is a sample of NewCenturySchoolbook-It font.*
- 60    ***This is a sample of NewCenturySchoolbook-BdIt font.***
- 61    This is a sample of Times-Rom font.
- 62    **This is a sample of Times-Bd font.**
- 63    *This is a sample of Times-It font.*
- 64    ***This is a sample of Times-BdIt font.***
- 65    *This is a sample of ITCZapfChancery-MdIt font.*
- 66    Τηισ ισ α σαμπλε οφ Συμβολ φοντ. (Symbol)
- 67    Τηισ ισ α σαμπλε οφ ΣυμβολΠΣ φοντ. (SymbolPS)





---

## KPDL Fonts (1)

**This is a sample of Albertus-ExtraBold font.**

This is a sample of Albertus-Medium font.

This is a sample of AntiqueOlive font.

**This is a sample of AntiqueOlive-Bold font.**

*This is a sample of AntiqueOlive-Italic font.*

This is a sample of Arial font.

**This is a sample of Arial-Bold font.**

***This is a sample of Arial-BoldItalic font.***

*This is a sample of Arial-Italic font.*

This is a sample of AvantGarde-Book font.

*This is a sample of AvantGarde-BookOblique font.*

**This is a sample of AvantGarde-Demi font.**

***This is a sample of AvantGarde-DemiOblique font.***

**This is a sample of Bookman-Demi font.**

***This is a sample of Bookman-DemiItalic font.***

This is a sample of Bookman-Light font.

*This is a sample of Bookman-LightItalic font.*

This is a sample of CGOmega font.

**This is a sample of CGOmega-Bold font.**

***This is a sample of CGOmega-BoldItalic font.***

*This is a sample of CGOmega-Italic font.*

This is a sample of CGTimes font.

**This is a sample of CGTimes-Bold font.**

***This is a sample of CGTimes-BoldItalic font.***

*This is a sample of CGTimes-Italic font.*

**This is a sample of Clarendon-Condensed-Bold font.**

*This is a sample of Coronet font.*

This is a sample of Courier font.

**This is a sample of Courier-Bold font.**

***This is a sample of Courier-BoldOblique font.***

*This is a sample of Courier-Oblique font.*

This is a sample of CourierPCL font.

**This is a sample of CourierPCL-Bd font.**

***This is a sample of CourierPCL-BoldItalic font.***

*This is a sample of CourierPCL-Italic font.*

This is a sample of Garamond-Antiqua font.

**This is a sample of Garamond-Halbfett font.**

*This is a sample of Garamond-Kursiv font.*

*This is a sample of Garamond-KursivHalbfett font.*



---

## Appendix B Options

---

This appendix explains how to expand the printer's memory and how to install each option unit. Also refer to the manuals of the respective option units.

This appendix explains the following option units:

- **Expanding the Printer Memory**
- **PF-60 Paper Feeder**
- **DU-60 Duplexer**
- **SO-60 Sorter**
- **EF-60 Envelope Feeder**
- **PT-4/PT-60 Face-up Output Tray**
- **Network Interface Card**
- **Microdrive (Hard Disk)**
- **CompactFlash (Memory) Card**

## Available Options

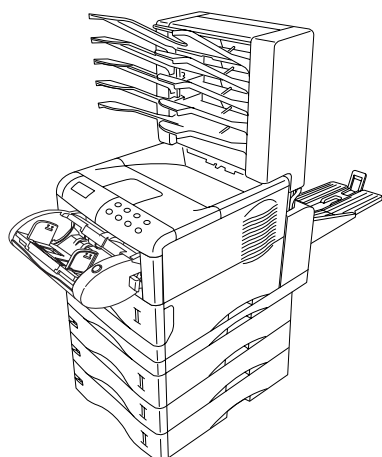
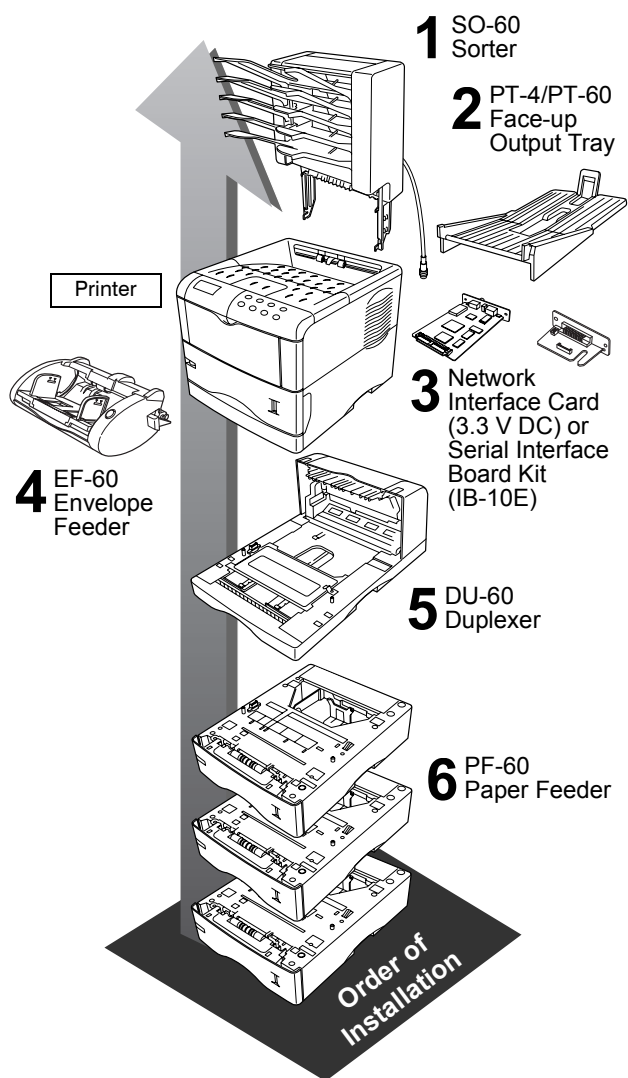

Printer combined with options

	<b>SO-60 Sorter</b>
1	Equipped with five trays each with 200 sheets capacity. Performs sorting, collating, and mailbox functions. Attaches to the top of the printer.
2	<b>PT-4/PT-60 Face-up Output Tray</b> This is a face-up tray. It attaches to the rear of the printer.
3	<b>Network Interface Card (IB-21)</b> Enables printing from multiple computers via a network if you install the special-purpose utility KPrint. (KPrint is included in the Kyocera Mita Network Library CD-ROM supplied with IB-21.) For details, see <a href="#">Configuration Guide</a> in the CD-ROM supplied with IB-21.
	<b>Serial Interface Board Kit (IB-10E)</b> Connect to the computer's serial printer port with a serial cable.
4	<b>EF-60 Envelope Feeder</b> Holds more envelopes at a time than the MP tray. It can be attached to the front of the printer after the MP tray has been removed.
5	<b>DU-60 Duplexer</b> Performs duplex printing for short edge and long edge binding. Attaches to the bottom of the printer.
6	<b>PF-60 Paper Feeder</b> Holds approximately 500 sheets of A5 to A4/Letter and Legal size paper. Up to three paper feeders can be attached to the bottom of the printer.
	<b>Other Options</b>
	<ul style="list-style-type: none"> <li>• <b>Bulk Feeder (PF-8E)</b> Holds approximately 2,000 sheets of A5 to A4/Letter and Legal size paper. It can be attached to the front of the printer after the MP tray has been removed.</li> <li>• <b>Bulk Stacker (HS-8E)</b> This bulk stacker can hold up to 2,000 copies for a continuous, voluminous output. It attaches to the rear of the printer.</li> <li>• <b>Paper Cassette (PC-60LG)</b> Holds A5 to A4/Letter and Legal size paper.</li> <li>• <b>Microdrive (Hard Disk Unit)</b> Enables the electronic sorting and job retention functions. To be inserted into the slot designed for it on the main circuit board of the printer. See your dealer for purchasing information regarding the Microdrives that are best suited for use with this printer.</li> <li>• <b>CompactFlash Card</b> This is a microchip card that may contain option fonts, macros, and forms. Insert the card into the card slot located near the handle on the right of the printer. See your dealer for purchasing information regarding the CompactFlash Cards that are best suited for use with this printer.</li> <li>• <b>Memory DIMM</b> See your dealer for purchasing information of the DIMM that are best suited for use with this printer. See <a href="#">Expanding the Printer Memory</a> for the installation procedure.</li> </ul>

## Expanding the Printer Memory

This section explains how to expand the printer's memory. Expanded printer memory enables you to print more complex pages, download more fonts, and define more macros.

This section first explains how to remove the main circuit board and then how to install a DIMM (Dual In-line Memory Module) on the main circuit board.

This printer comes supplied with 16 MB of memory installed. Two sockets are provided for expanding the printer memory to allow more complex printing jobs and increase the printing speed. By installing DIMM into your printer, the memory in the printer can be increased to a maximum of 144 MB.



Note

**The expansion memory should be installed only by a Kyocera Mita authorized dealer or Kyocera Mita certified technician. Kyocera Mita shall not be liable for damage due to improper installation of the expansion memory.**

### Removing the Main Circuit Board

The main circuit board of the printer is equipped with two sockets for memory expansion. Expansion memory is available in the form of DIMM.



Note

The following instructions are intended for the technician only.

#### Notes on Handling the Main Circuit Board and DIMM

Protect the electronics by taking these precautions:

- Before touching the main circuit board and DIMM, touch a water pipe or other large metal object to discharge yourself of static electricity. While doing the work, it is recommended that you wear an antistatic wrist strap.
- Touch the main circuit board and DIMM only at the edges.

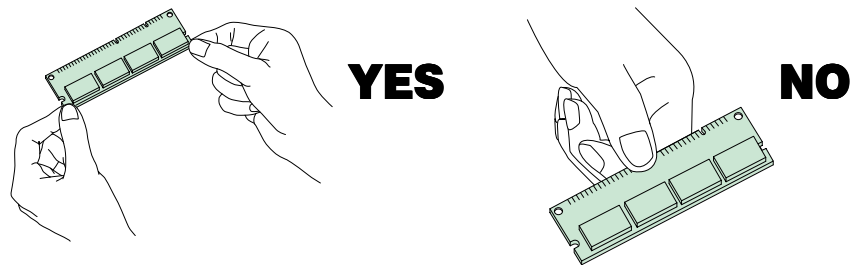

### Removing the Main Circuit Board from the Printer



Note

Be sure to remove the CompactFlash Card (memory card) first if inserted in the printer's card slot.

Remove the main circuit board completely from the printer as follows:

- 1 Turn the printer off and unplug its power cord. Disconnect the printer from the host computer.

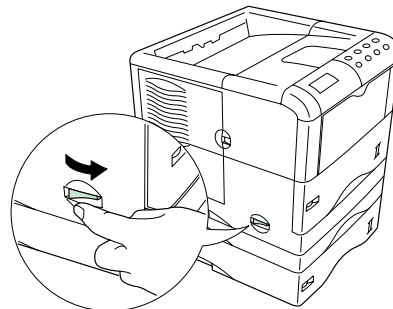

- 2** Remove the two screws from the printer's rear panel.

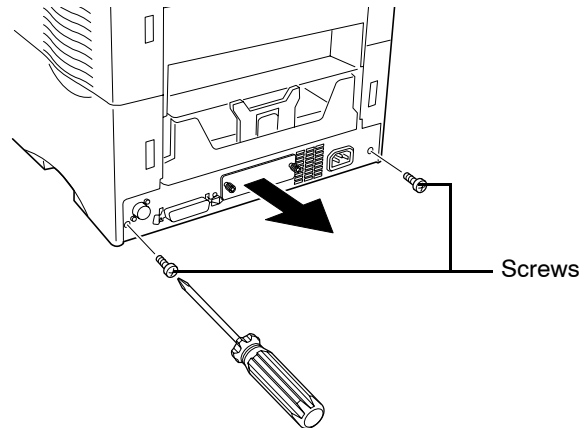

- 3** Pull the main circuit board all the way out of the printer.

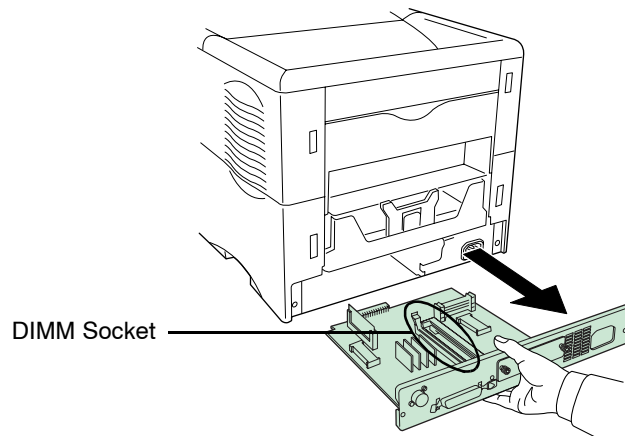

Note

**Before pulling the main circuit board out, clear away the area, behind the printer. Foreign objects, accidentally sticking to the back of the main circuit board, can cause serious damage to the printer.**

Install the DIMM as described on the following page.

### DIMM to be used

16 MB, 32 MB, 64 MB, and 128 MB DIMM can be used for memory expansion. See your Kyocera Mita dealer for purchasing information of the DIMM that are best suited for use with this printer.

### Installing DIMM

Insert the DIMM into the socket as shown below.

- 1** Remove the DIMM from its package.
- 2** Open the clips on both ends of the DIMM socket.
- 3** Insert the DIMM into the socket, so that the notches on the DIMM align with the corresponding protusions in the socket.
- 4** Close the clips of the DIMM socket to secure the DIMM.
- 5** When you finish installing the DIMM, reinsert the main circuit board into the printer by reversing the removal procedure.

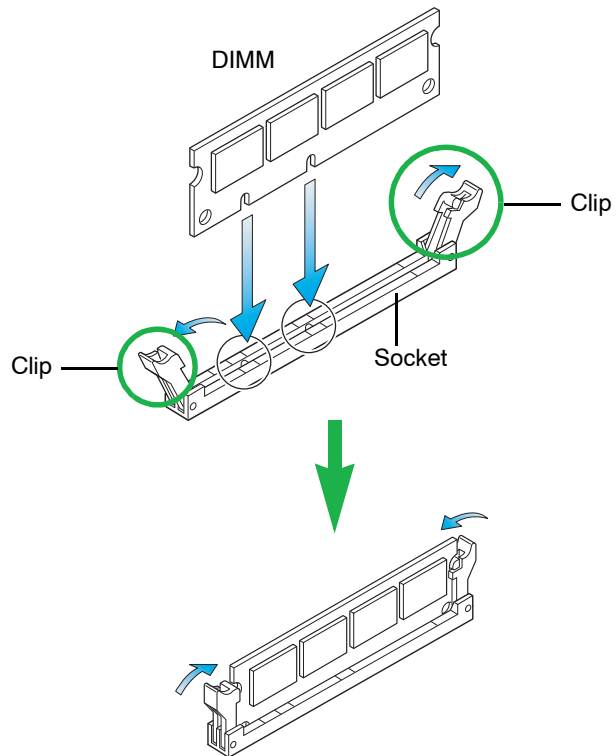



### Removing DIMM

To remove a DIMM, carefully pull the end clips outwards, then pull the DIMM out of the socket.

Return the main circuit board to the printer by reversing the procedure explained in *Removing the Main Circuit Board from the Printer*.

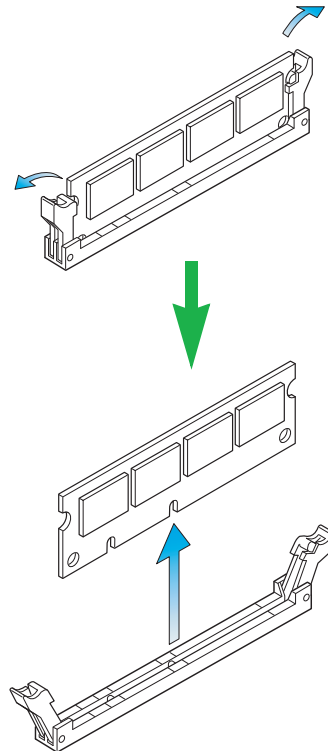

### Testing the Expansion Memory

After you finish installing DIMM in the printer, test the printer to see if the installation was successful.

To test the expansion memory, proceed as follows:

- 1** Make sure printer is turned off. Plug the power cord into the printer and turn the printer on.
- 2** Press the **MENU** key on the operator panel.
- 3** Press the **^** and **v** key repeatedly until Print Status Page appears.
- 4** Press the **ENTER** key twice.
- 5** If the installation was successful, the amount of memory shown on the status page will correspond with the amount of expanded memory. (The factory installed memory size is 16 MB.)

### Adjusting the Memory on the Printer Driver

After you install the additional memory to the printer, follow the instructions below to set the printer driver so that the printer can use the memories efficiently.

- 1 Click the Windows **Start** button, point to **Settings** then click **Printers**.
- 2 Right click the **Kyocera Mita FS-1900 KX** icon, and click **Properties**.  
The **Properties** dialog box will open. Click the **Device Settings** tab.
- 3 Enter the total memory size installed to the printer (up to 144 MB) in the **Memory** box.

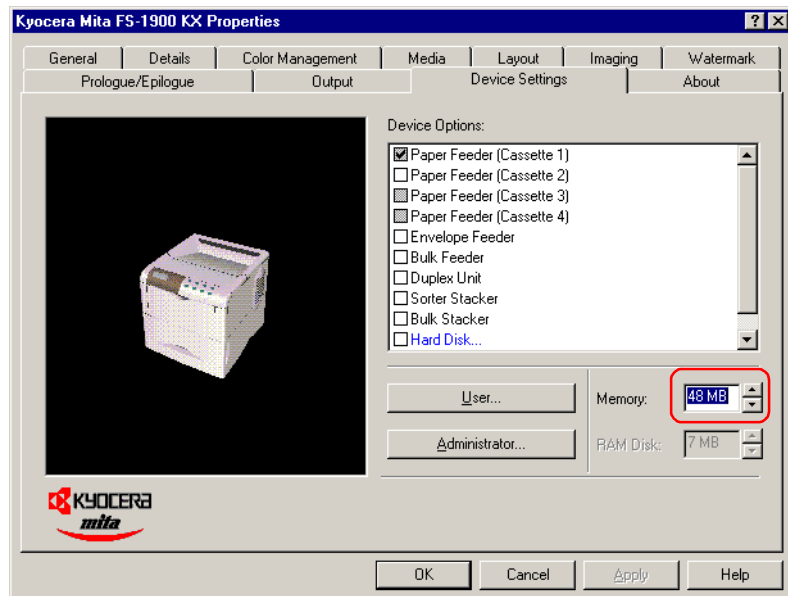

- 4 Click the **OK** button to close the window.

## Installing Option Units

### PF-60 Paper Feeder

Up to three option paper feeders can be installed below the printer. A paper feeder can hold approximately 500 sheets of paper at a time. By using option paper feeders in conjunction with the printer paper cassette, which can also hold approximately 500 sheets of paper, up to approximately 2,000 sheets of paper can be fed continuously. The paper cassette of the paper feeder can feed Legal size paper.



Note

**When installing more than one paper feeder, first stack the paper feeders together.**

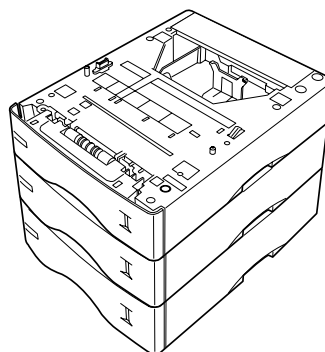

- 1** Turn off the printer and disconnect the power cord and printer cable.
- 2** Gently place the printer on top of the paper feeder(s).

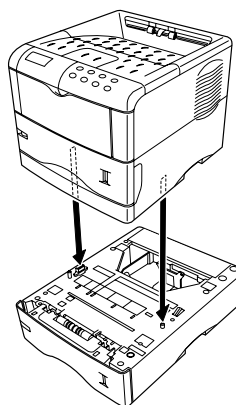

- 3** Pull the paper cassette all the way out of the paper feeder.

- 4** Push down the bottom plate until it locks.

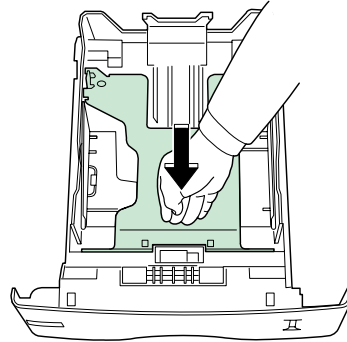

- 5** Set the paper size dial to the size of paper to be used.

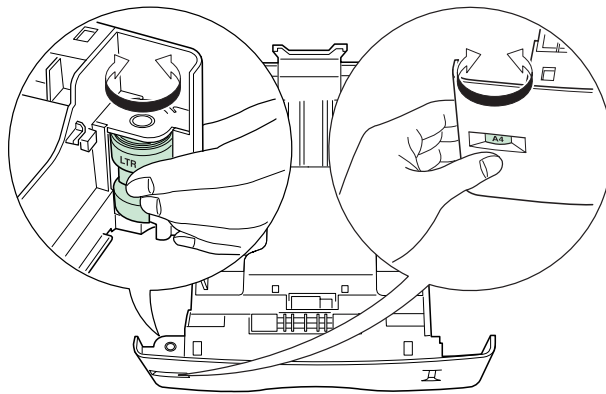

- 6** Adjust the paper guides and paper stopper to the size of paper to be used.

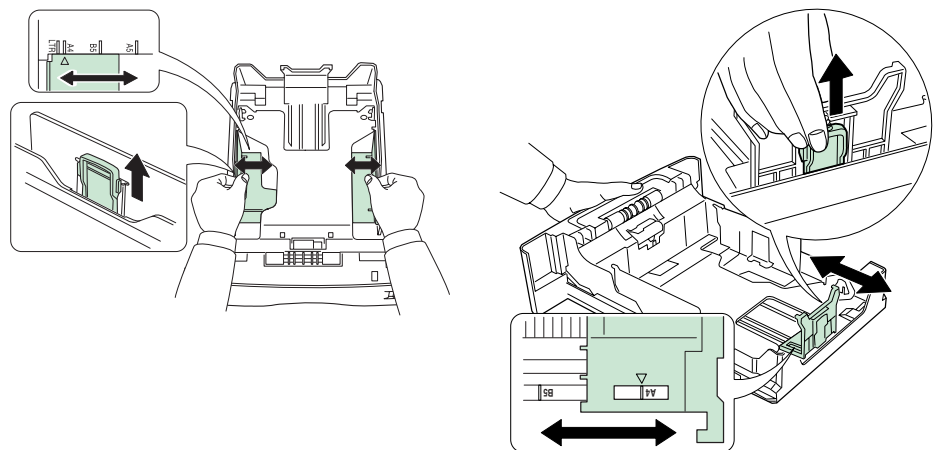

## 7 Load paper.

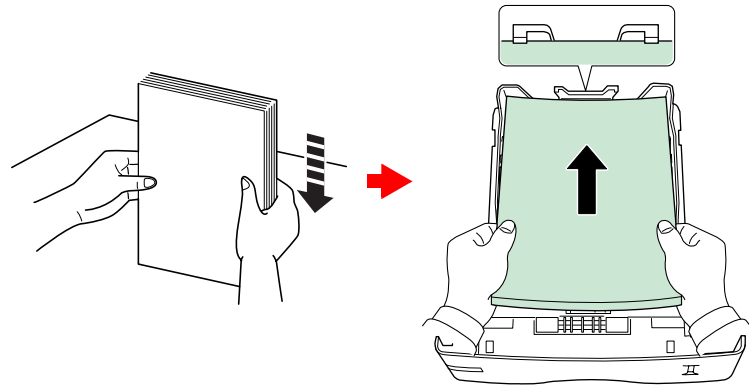

Note

- Do not load more paper than will fit under the load limits on the paper guides.
- The paper cassette will hold approximately 500 sheets of paper with a 80 g/m<sup>2</sup> (21 lb) basis weight, or with a thickness of 0.11 mm.

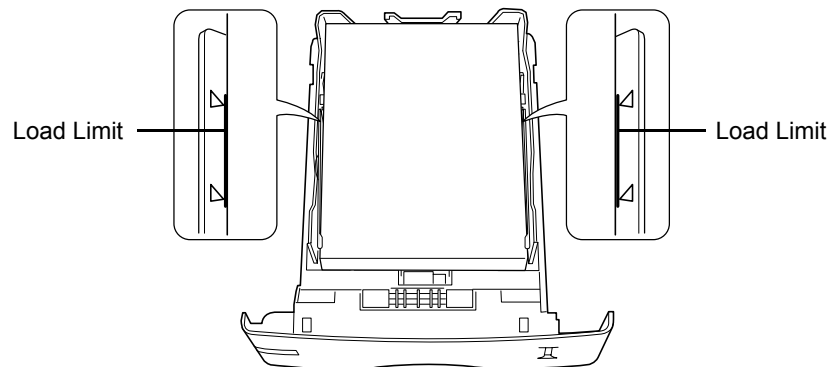

## 8 Set the stack of paper so that it is under the clips as shown in the figure.

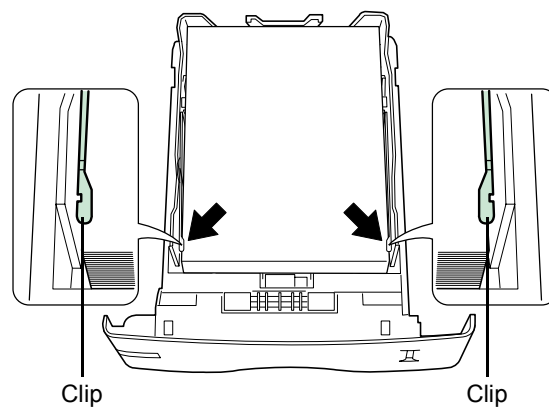

## 9 Insert the paper cassette back in.

## DU-60 Duplexer

Install the option duplexer immediately below the printer. By combining the two binding modes (short edge bind and long edge bind) with the two printing orientations (portrait and landscape), duplex printing is possible in four different methods. Duplex printing can be specified from the application (printer driver).

- 1** Remove the nine tapes and the pad from the duplexer.

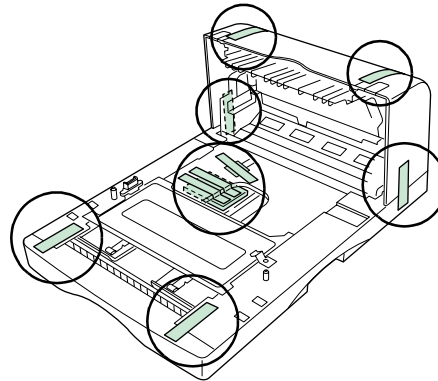

- 2** While pushing the rear cover release lever inward, remove the duplexer rear cover.

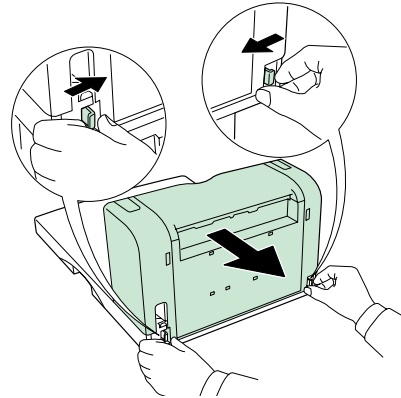

- 3** Turn off the printer and disconnect the power cord and printer cable.

- 4** Gently place the printer on top of the duplexer.

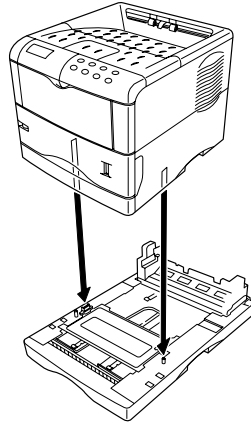

- 5** Connect the printer cable (parallel interface cable, USB interface cable, serial interface cable or network interface cable) according to your operation environment.

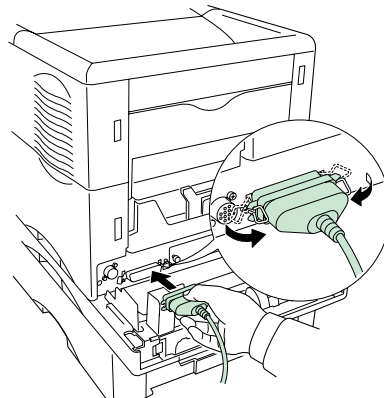

- 6** Connect the power cord to the printer.

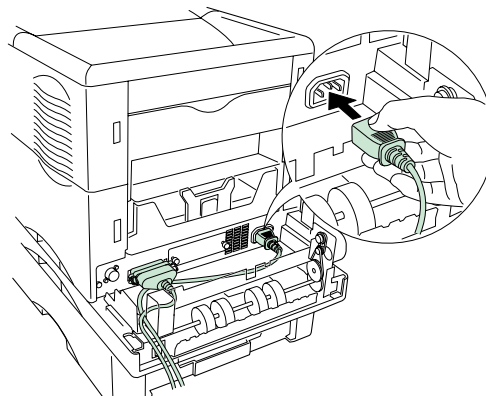

- 7** Pass the connected cable and power cord through the opening in the duplexer.

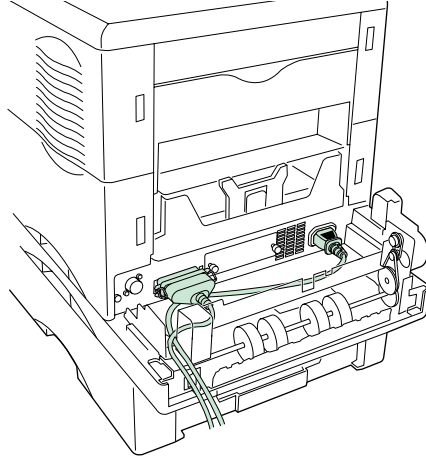

- 8** Install the duplexer rear cover.

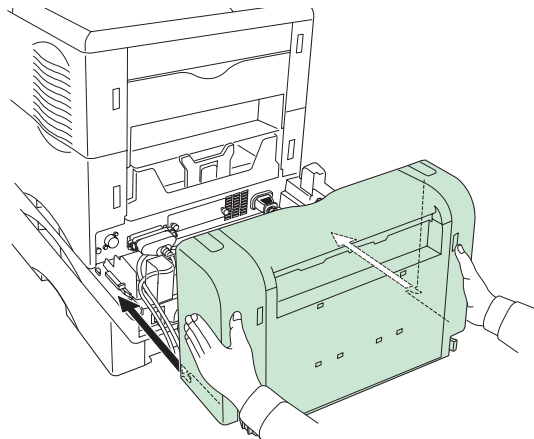



## SO-60 Sorter

Install the option sorter on top of the printer. It is equipped with five sorter trays, with a capacity of 200 sheets each. There are three modes in which printouts can be received: the sorter mode, the collator mode, and the mail box mode (for details about the modes, refer to the *Printer Drivers Guide*).

The following installation procedure explains how to install the sorter when the option paper feeder (PF-60) and duplexer (DU-60) have already been installed.

- 1 Unpack the sorter and place it on its side.
- 2 Remove the tapes from the sorter.

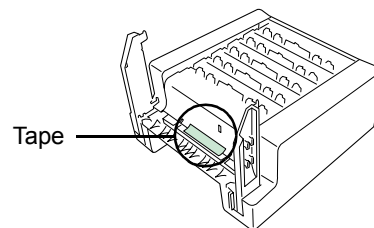
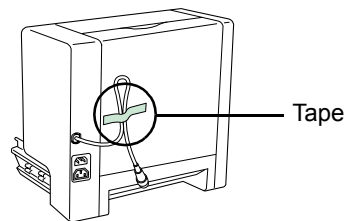

- 3 Unfold the two attachment legs of the sorter.

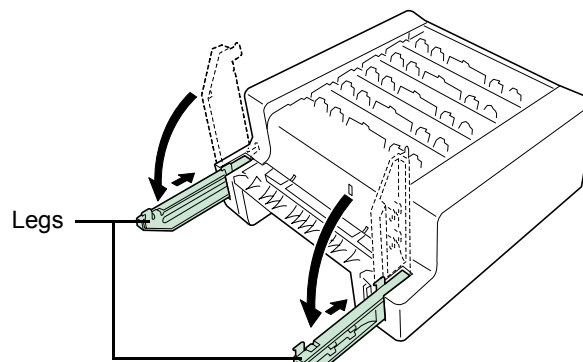

- 4 Turn off the printer and disconnect the power cord and printer cable.

- 5** If the duplexer is installed, remove the duplexer rear cover, power cord, and printer cable.

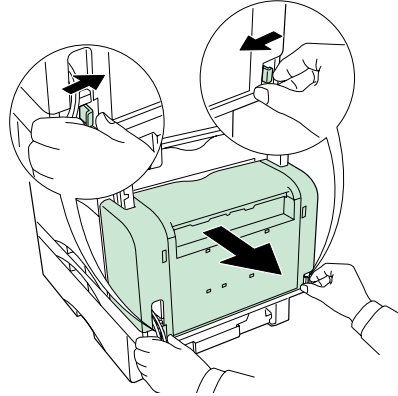

- 6** Remove the sorter connection cover from the printer. Store the removed cover in a safe place.

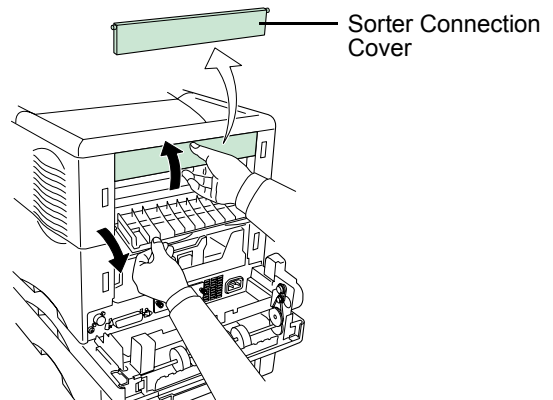

- 7** Install the sorter by inserting the four hooks on its attachment legs into the notches in the printer.

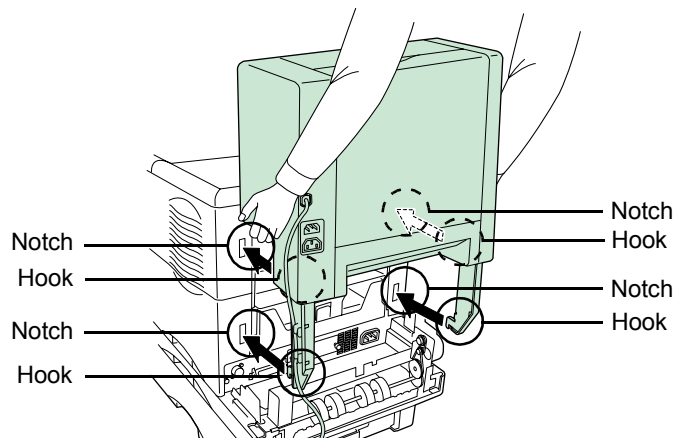

- 8** Push the sorter down. The levers of the attachment legs are in the lock position.

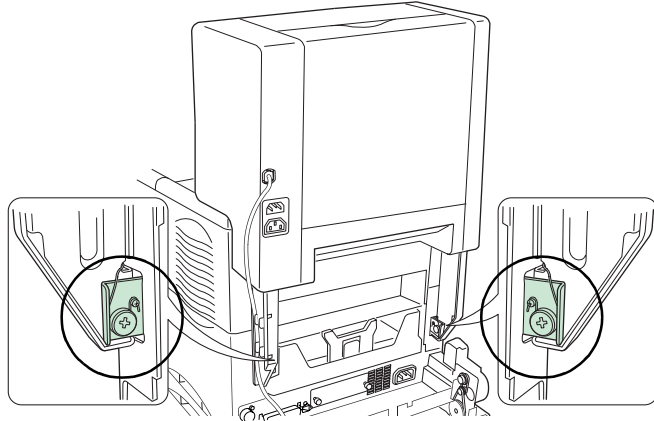

When removing the sorter, unlock the attachment legs by releasing the levers as shown in the figure one by one, and then lift the sorter.

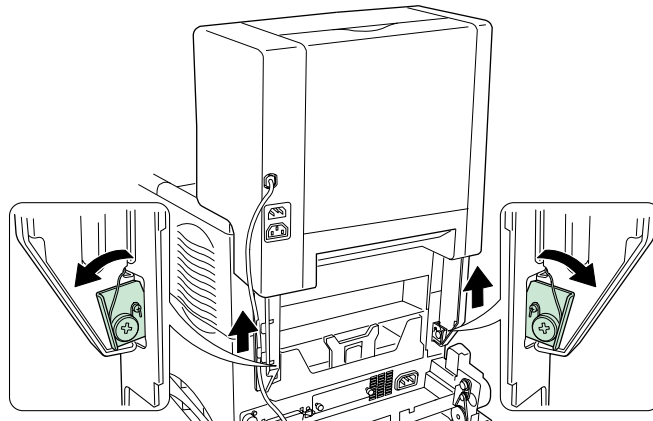

- 9** Connect the sorter cable to the printer.

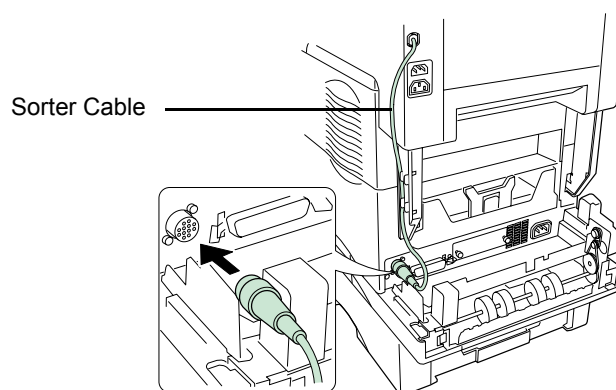

When disconnecting the sorter cable, hold the grip on the connector as shown in the figure and then pull it out.

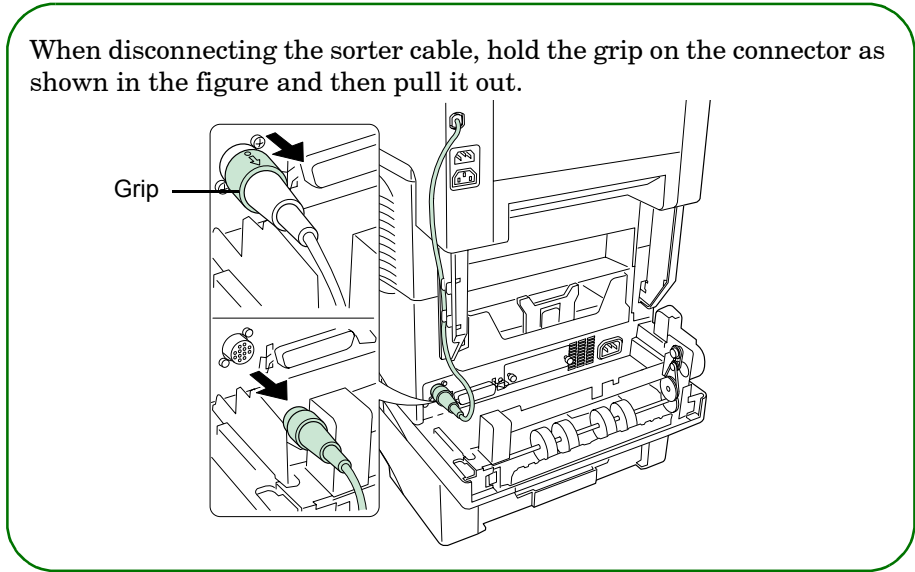

**10** The sorter is equipped with two power cord sockets. The upper one is to be connected to a power outlet and the lower one is to be connected to the printer.

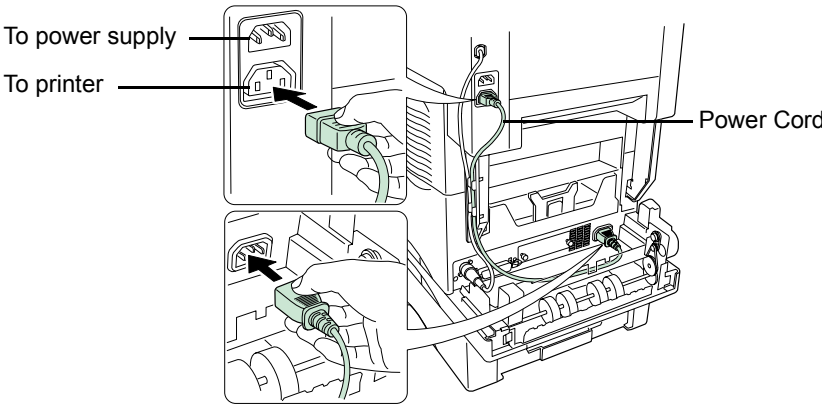

**11** Secure the connected sorter cable and power cord to an attachment leg on the sorter.

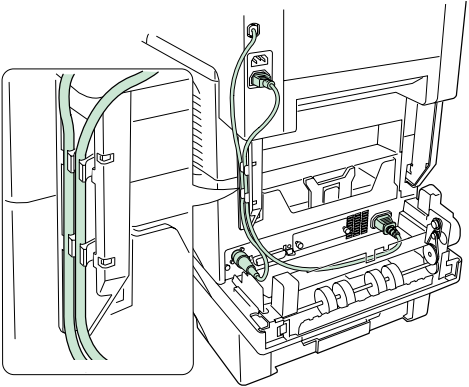

- 12** If the duplexer is installed, secure the power cord to the duplexer. Take care not to loosen the power cord.

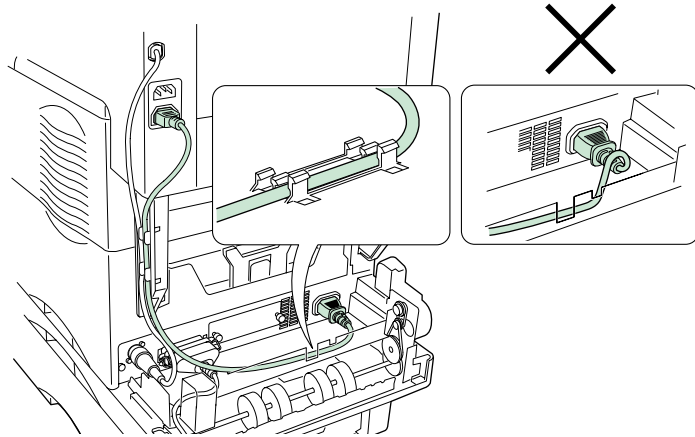

- 13** If the duplexer is installed, remove the two cut-out portions from the upper part of the duplexer rear cover removed in step 5.

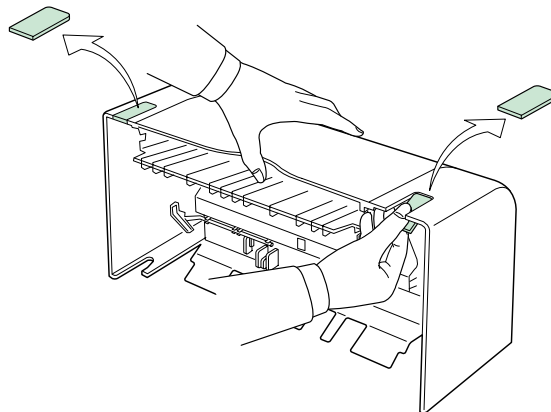

- 14** Reinstall the duplexer rear cover.

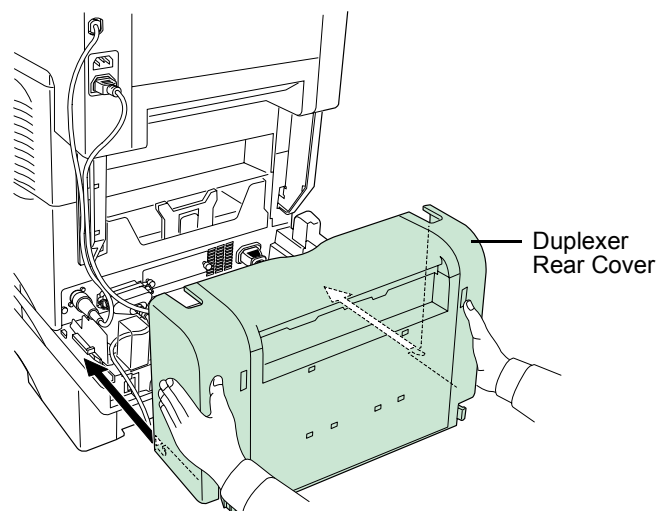

**15** Install the five sorter trays to the sorter.

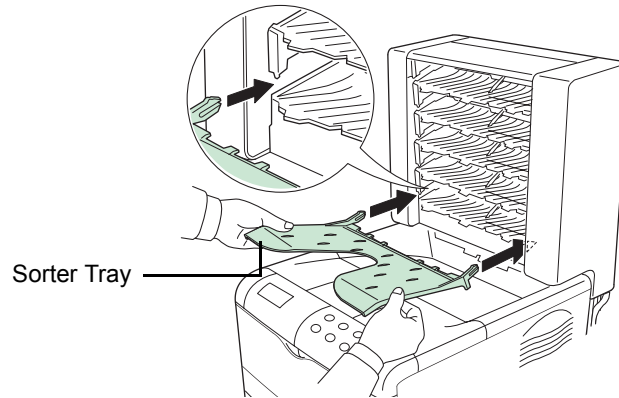

**16** Connect the power cord supplied with the printer to the sorter.

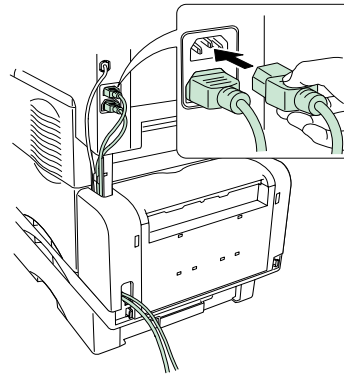

**Do not move or lift the printer with the sorter installed.**

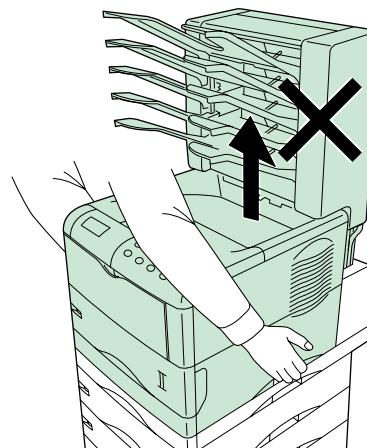

## EF-60 Envelope Feeder

Install the option envelope feeder at the front of the printer. By installing the envelope feeder, you can print on a wide variety of different envelope sizes. And the EF-60 feeds envelopes automatically, making it easy to print on large quantities of envelopes at one time.

### Installing the envelope feeder on the printer



Note

Turn OFF the power to the printer before installing the envelope feeder.

- 1 Pull the printer's paper transfer unit release lever (green colored), then draw the paper transfer unit fully out of the printer.

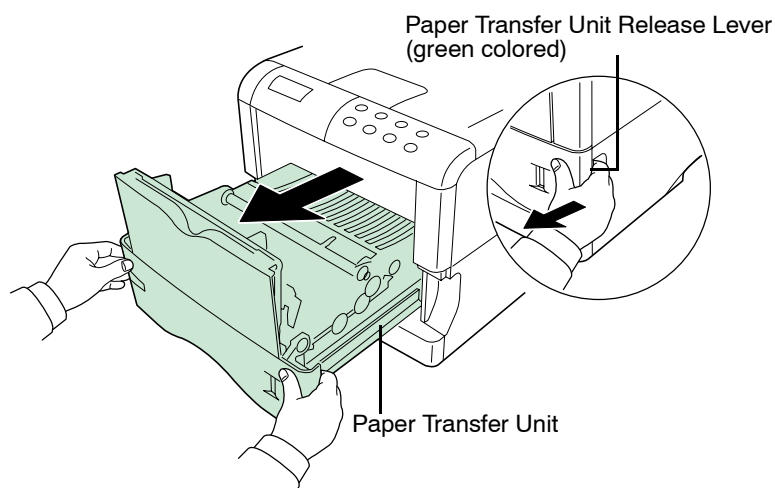

- 2 Gently tilt the MP tray toward the printer until that it rests on its side as shown in the figure, and remove the MP tray from the printer by lifting it straight upward.

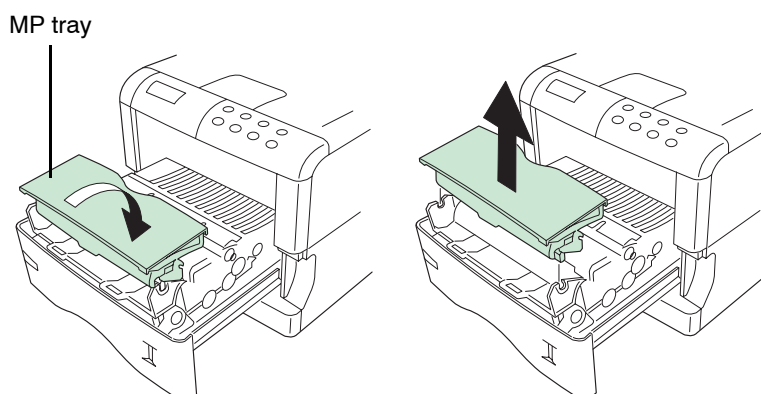

- 3 Fit both ends of the envelope feeder into their mountings on the paper transfer unit as shown in the figure and lay the envelope feeder down toward you.

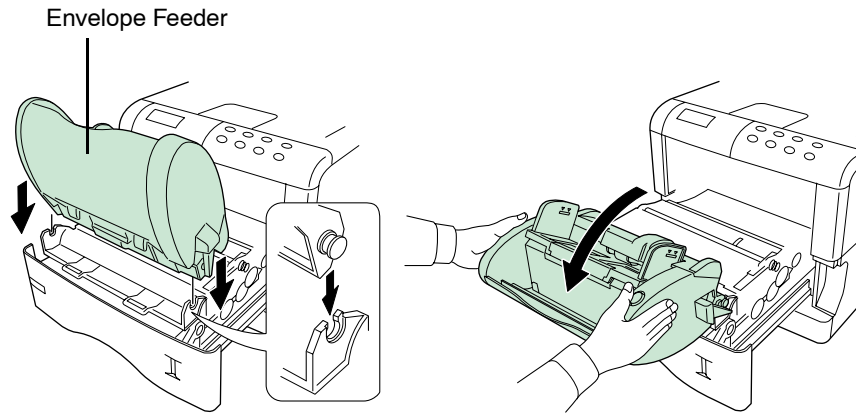

- 4 Return the paper transfer unit into the printer with the envelope feeder mounted.

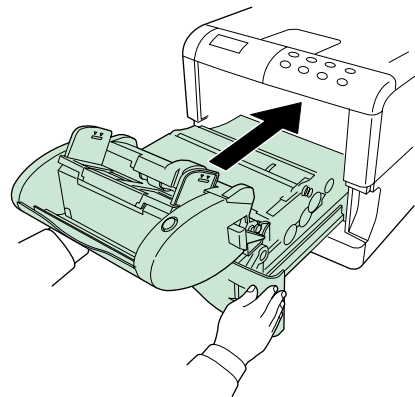

### Load envelopes into the envelope feeder

- 1 Push the bottom tray downward, as shown in the figure, until you hear a clicking sound to secure it.

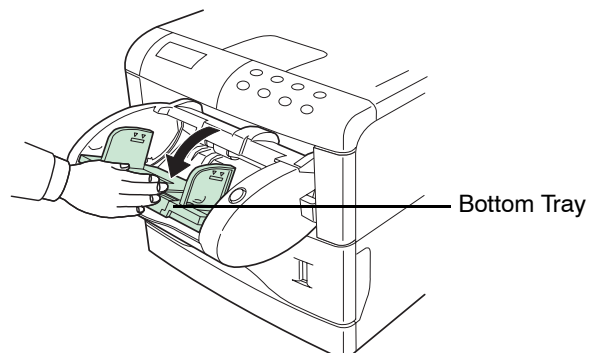



- 2** Pull out the sub-tray that matches the size of the envelopes.

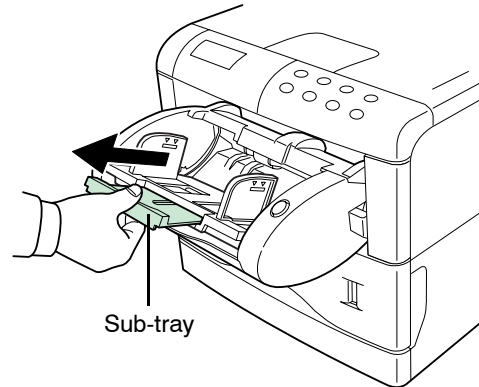

- 3** Load envelopes into the envelope feeder so that they feed in face up, right edge first. Then adjust the envelope feeder's paper guides to the width of the envelope.

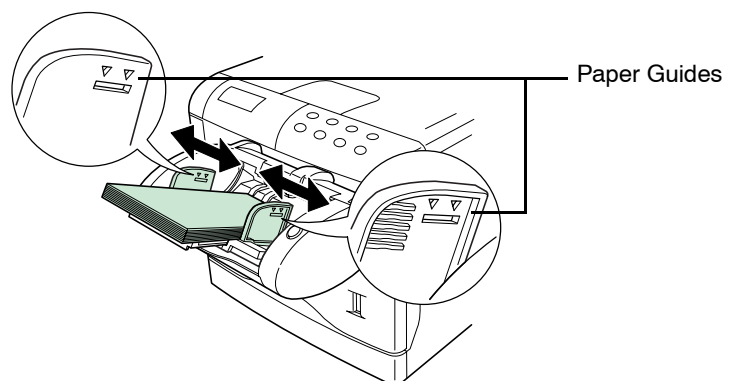

Note

- Do not set different types of envelopes into the feeder at the same time.
- Do not load envelopes into the envelope feeder higher than the limitation marks (▼▼) on either side of the feeder.
- Do not force paper into the envelope feeder. Damage to the mechanism may result.

- 4** Press the paper setting button. The envelope feeder's bottom tray is lifted and envelopes that are fed are secured to the envelope feeder.

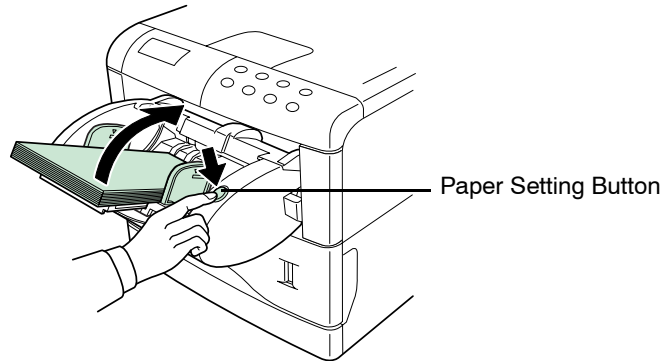

Note

- Paper feed errors may occur when using large envelopes. If this happens, remove the envelopes and move the switch to the up (  ) position as shown in the figure. This improves seating of the envelopes in the envelope feeder.
- Do not touch envelopes while they are being fed, or attempt to pull an envelope back once it starts being fed. Damage to the mechanism may result.
- To avoid trouble, we recommend that envelopes be delivered face-up using the option face-up output tray. Refer to *next page*.

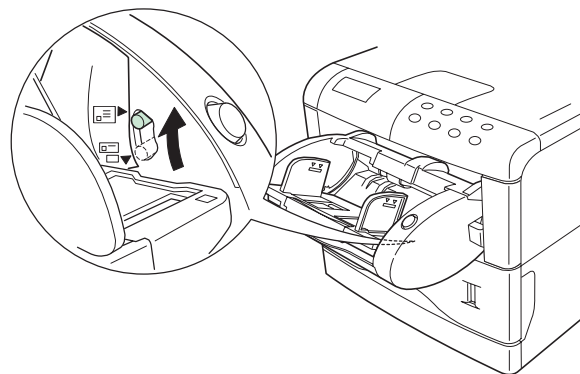

## PT-4/PT-60 Face-up Output Tray

Use the face-up output tray when you wish paper to be stacked with the printed side facing up (reverse order), or when you are printing on envelopes, postcards, transparencies, or thick paper. When installing it directly to the printer, use PT-4. If an option duplexer has been installed, use PT-60.

- 1 Install the paper stopper according to the size of paper to be used. (same for both PT-4 and PT-60)

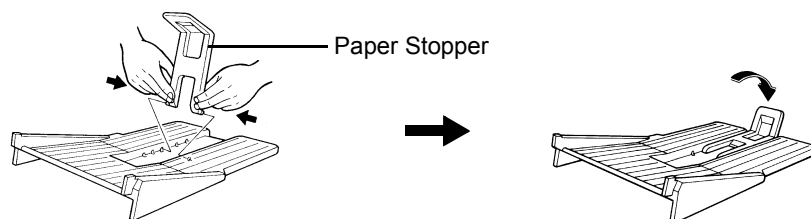
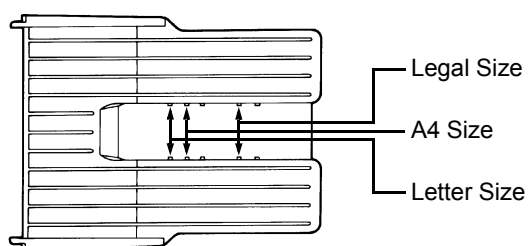

- 2 Install the face-up output tray on the rear of the printer.

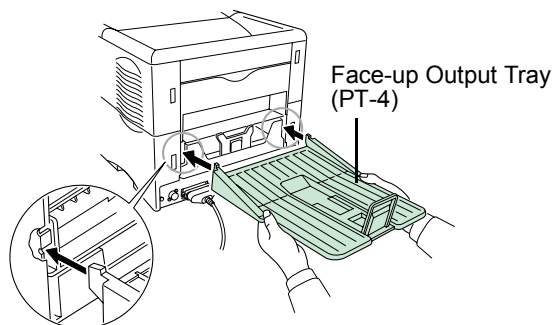

When installing directly to the printer

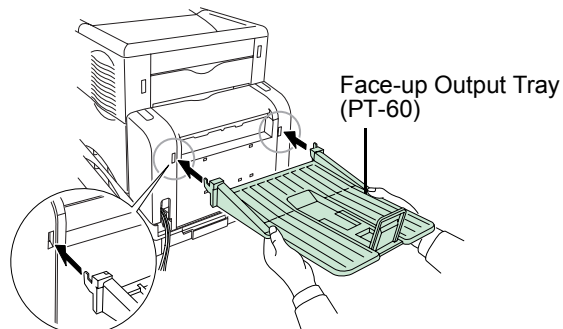

If a duplexer has been installed to the printer

## Network Interface Card

Insert the option network interface card into the option interface slot at the rear of the printer. The network interface card enables the printer to be used in a network.

- 1** Turn off the printer and disconnect the power cord and printer cable.
- 2** Remove the two screws from the option interface slot cover.

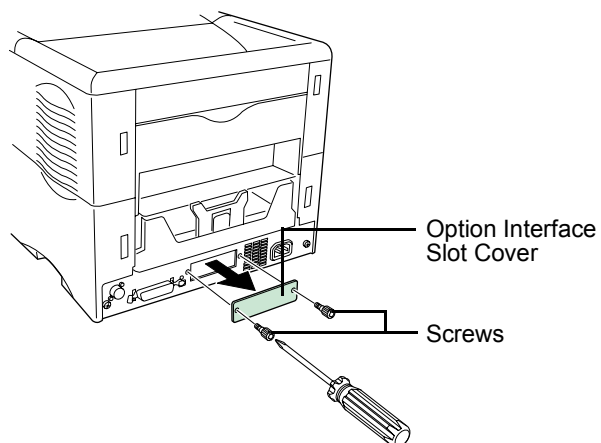

- 3** Insert the network interface card and secure it with the screws removed in step 2.

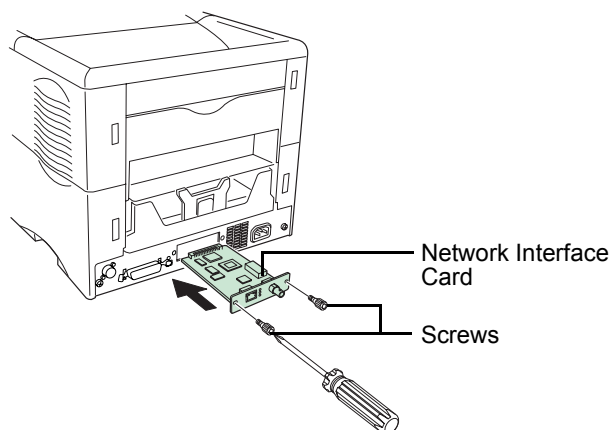

- 4** Connect the network cable.

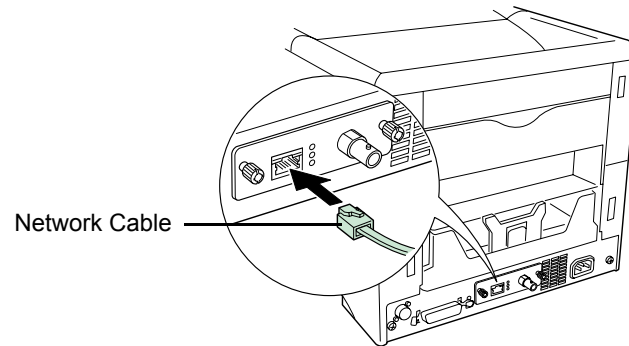

- 5** Set the network address from the printer operator panel (for details about the modes, see [Network Interface Parameters](#) on page [1-78](#)).

## Microdrive (Hard Disk)

Insert the Microdrive into its slot on the main circuit board of the printer. If a Microdrive is installed in the printer, received data can be rasterized and stored on this Microdrive. This enables high-speed printing of multiple copies using an electric sort function. Also, you can use the e-MPS functions. For details, see [e-MPS](#) on page [1-56](#).

For details of available Microdrives, see your dealer.

- 1** Turn off the printer and disconnect the power cord and printer cable.
- 2** Remove the two screws from the rear panel.

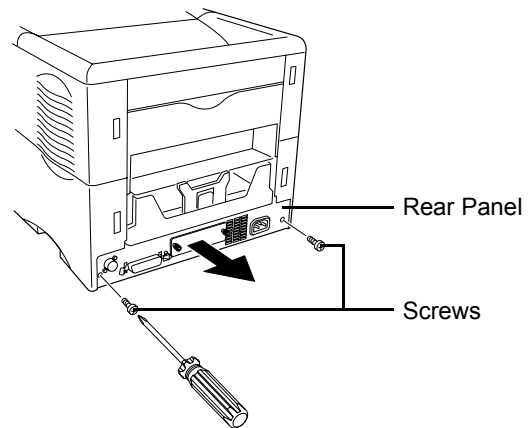

- 3** Pull the main circuit board all the way out of the printer.

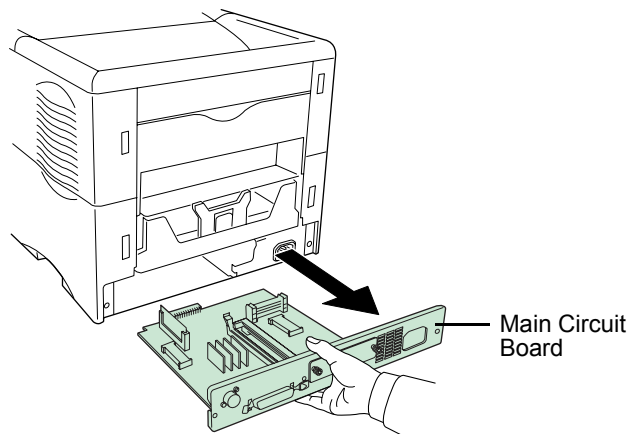

- 4** Install the Microdrive into its slot on the main circuit board.

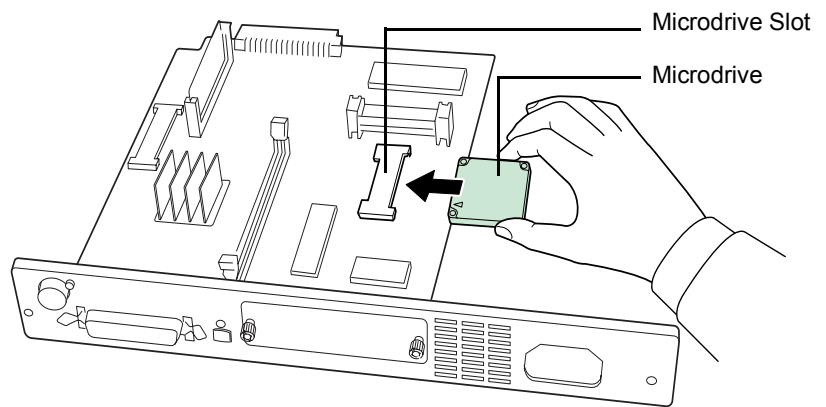

- 5** Return the main circuit board to the printer by reversing the procedure followed when removing it.

## CompactFlash (Memory) Card

Insert the CompactFlash card into the card slot located near the handle on the right of the printer. A CompactFlash card is a microchip card that may contain option fonts, macros, forms, etc. The printer reads the contents of the card into its internal memory when printer is turned on. The presence of this data in the printer memory can be confirmed on the status printout.

For details of available CompactFlash cards, see your dealer.

- 1 Turn off the printer.



Note

**Do not insert or remove a CompactFlash card while power is on. If the CompactFlash card is removed while the printer is on, damage could result in the printer's electronics or the CompactFlash card.**

- 2 Insert the CompactFlash card in the slot. Insert it face up, connector end first. Push it in all the way.

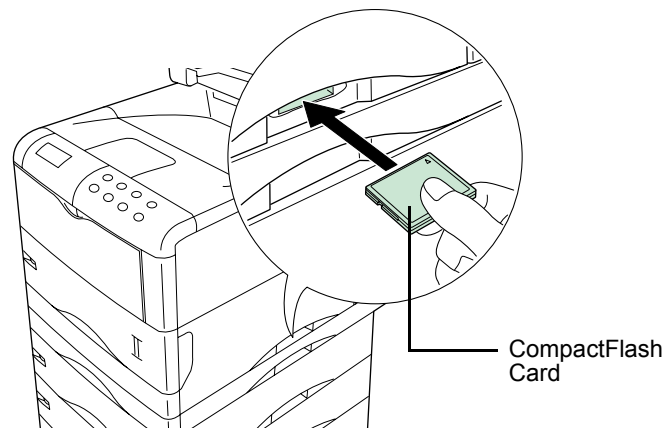



---

## Appendix C **Host Computer Interface**

---

This appendix explains the signals used in the printer's parallel and RS-232C interfaces. It also lists pin assignments, signal functions, timings, connector specifications, and voltage levels. The RS-232C protocols are also covered. Finally, it explains how to use the printer in a multi-computer environment.

This appendix explains the following topics:

- **Parallel Interface**
- **USB Interface**
- **Serial Interface (Option)**
- **RS-232C/RS-422A Protocol**
- **RS-232C Cable Connection**

## Parallel Interface

### Parallel Interface Communication Modes

The printer features fast data transmission with the parallel interface. The parallel interface mode can be activated from the operator panel. See [Parallel Interface Mode](#) on page 1-74.



Note

**Use a parallel printer cable that complies with the IEEE1284 standard.**

#### **Auto [default]**

The printer automatically changes its communication mode to the one the host computer is currently using.

#### **Nibble (high)**

High speed data communication is used in compliance with the IEEE1284 standard. Ordinarily, you should leave this setting unchanged.

#### **Normal**

The printer uses the standard communication method prescribed for Centronics interfaces.

#### **High-speed**

This mode enables faster data transmission between the printer and the host computer. (Select this mode if printing problems occur when the printer is connected to a workstation.)

### Interface Signals

The pins of the parallel interface connector carry the signals listed in the table in [Parallel Connector Pin Assignment](#) on page C-3. Asterisks in the table indicate signals that are active low. The table also indicates whether each signal is incoming or outgoing with respect to the printer.

## Parallel Connector Pin Assignment

Pin	In/out	Description
1	In	Strobe* [nStrobe]
2	In/Out	Data 0 [Data 1]
3	In/Out	Data 1 [Data 2]
4	In/Out	Data 2 [Data 3]
5	In/Out	Data 3 [Data 4]
6	In/Out	Data 4 [Data 5]
7	In/Out	Data 5 [Data 6]
8	In/Out	Data 6 [Data 7]
9	In/Out	Data 7 [Data 8]
10	Out	Acknowledge* [nAck]
11	Out	Busy [Busy]
12	Out	Paper Empty [PErrror], returns paper empty status if FRPO O2=2
13	Out	Select (Online) [nSelect], returns off-line status if FRPO O2=2
14	In	Auto-feed [nAutoFd]
15	-	Not connected
16	-	0 V DC
17	-	Chassis GND
18	-	+5 V DC
19	-	Ground
20	-	Ground
21	-	Ground
22	-	Ground
23	-	Ground
24	-	Ground
25	-	Ground
26	-	Ground
27	-	Ground
28	-	Ground
29	-	Ground
30	-	Ground
31	In	Ignored [nInit]
32	Out	Error*, returns error status if FRPO O2=2 [nFault]
33	-	Not connected
34	-	Not connected
35	Out	Power Ready
36	In	Ignored [nSelectIn]

[\*]: Signal names in the Auto mode and Nibble (high) mode (IEEE1284). In the Auto mode and Nibble (high) mode, these signals are bi-directional.

Detailed descriptions of the signals follow.

**Strobe\* [nStrobe] (Pin 1)**

A negative-going Strobe\* pulse causes the printer to read and latch the data on the Data 0 [1] to Data 7 [8] signal lines.

**Data 0 [1] to Data 7 [8] (Pins 2 to 9)**

These eight signals form the data byte sent from the host computer to the printer. Data 7 [8] is the most significant bit.

**Acknowledge\* [nAck] (Pin 10)**

This negative-going pulse acknowledges the previous character received by the printer.

**Busy [Busy] (Pin 11)**

This signal is high when the printer is busy and low when it is able to accept more data.

**Paper Empty [PError] (Pin 12)**

This signal goes high when the printer has received a print job and run out of paper.

**Select [Online] (Pin 13)**

This signal is high when the printer is online and low when the printer is offline. It goes low when the **GO** key is pressed to set the printer offline.

**+5 V DC (Pin 18)**

This line is connected to the printer's +5 V DC line (+5 V  $\pm$ 0.5 V, maximum 400 mA, fused).

**Error\* [nFault] (Pin 32)**

When the high-speed parallel line control is on (FRPO O2=2), this line returns error status.

**Power Ready (Pin 35)**

This signal is high when the printer is turned on.



Note

**The Paper Empty, Online, and Error signals are not used unless enabled by the FRPO command (O2 parameter).**

## USB Interface

This printer supports the USB (Universal Serial Bus) Revision 1.1 standards. USB interface specifications and interface signals are as follows.

### Specifications

#### Basic specification

Complies with the USB Revision 1.1 standards.

#### Connectors

Printer: B-type receptacle (female) with upstream port

Cable: B-type plug (male)

#### Cable

Use shielded cable that complies with the USB Revision 1.1 standards and not longer than 5 meters (16 feet).

#### Transfer Mode

Full speed (max. 12 Mbps)

#### Power Control

Self-power device

### Interface Signals

Pin	Signal	Description
1	Vbus	Power supply (+5 V)
2	D-	Data transmission
3	D+	Data transmission
4	GND	Signal ground
Shell		Shield

## Serial Interface (Option)

Installing the optional serial interface board kit (IB-10E) in the printer enables connection to a computer with an RS-232C or RS-422A standard serial interface.

### RS-232C Interface

#### Interface Signals

The pins of the printer's RS-232C interface connector carry the signals listed in table below. The table also indicates whether each signal is incoming or outgoing with respect to the printer.

Pin	In/out	Signal	Description
1	-	FG	Frame ground
2	Out	TXD	Transmit Data
3	In	RXD	Receive Data
4	Out	RTS	Request To Send
5	In	CTS	Clear To Send
6	In	DSR	Data Set Ready
7	-	SG	Signal Ground
20	Out	DTR	Data Terminal Ready

Brief descriptions of the signals follow.

#### **FG - Frame Ground - (Pin 1)**

This pin is connected directly to the printer frame.

#### **TXD - Transmit Data - (Pin 2)**

This output carries asynchronous data sent by the printer to the computer. It is used mainly in handshaking protocols.

#### **RXD - Receive Data - (Pin 3)**

This input carries serial asynchronous data sent by the computer to the printer.

#### **RTS - Request To Send - (Pin 4)**

This output is always held high (above 3 volts).

#### **CTS - Clear To Send - (Pin 5)**

#### **DSR - Data Set Ready - (Pin 6)**

Unused.

**SG - Signal Ground - (Pin 7)**

All signals can transmit between the printer and the host computer to send each signal with a signal ground.

**DTR - Data Terminal Ready - (Pin 20)**

This output is used as a buffer nearly-full handshake line. It is held high (above 3 volts) when the buffer can accept more data.

**RS-232C Interface Voltage Levels**

The voltage levels of the interface signals conform to EIA RS-232C specifications. SPACE is from 3 volts to 15 volts. MARK is from -3 volts to -15 volts. Voltages between -3 volts and 3 volts are undefined.

**RS-422A Interface**

The serial interface is set to the RS-232C mode as the factory default. However, by changing the jumper connector on the IB-10E interface board, the interface can be changed to the RS-422A mode.

**In the RS-232C mode**, the printer can be connected to a personal computer (or similar device) equipped with an RS-232C serial interface. (The serial interface is set to the RS-232C mode as the factory default.)

**In the RS-422A mode**, the printer can be connected to a personal computer (or similar device) equipped with an RS-422A serial interface.



Note

**Changing of the jumper connector should be carried out only by a Kyocera Mita authorized dealer or Kyocera Mita certified technician. Kyocera Mita shall not be liable for damage due to improper changing of the jumper connector.**

**Interface Signals**

The pins in the printer's RS-422A interface connector carry the signals listed in table below.

Pin	In/out	Signal	Description
1	-	FG	Frame ground
3	In	RDA	Receive data Inverted
7	-	SG	Signal ground
9	Out	SDA	Send data Inverted
10	Out	SDB	Send data
11	-	-	+5V DC
18	In	RDB	Receive data

### **Overview of Signals (RS-422A)**

#### **FG - Frame Ground - (Pin 1)**

This pin is connected directly to the printer frame.

#### **SG - Signal Ground - (Pin 7)**

All signals can transmit between the printer and the host computer to send each signal with a signal ground.

#### **RDB - Receive Data - (Pin 18)**

#### **RDA - Receive Data Inverted - (Pin 3)**

These pins carry asynchronous data sent from the computer to the printer. (differential input)

#### **SDB - Send Data - (Pin 10)**

#### **SDA - Send Data Inverted - (Pin 9)**

These pins carry asynchronous data sent from the printer to the computer. (differential output)

### **RS-422A Interface Voltage Levels**

The interface signal voltage levels conform with the EIA RS-422A standard. The differential voltage varies from 200 mV to 6 V.

### **SERIAL Connector**

The connector marked "IOIO" (RS-232C/RS-422A) on the rear panel is a DB-25S connector. Use a DB-25P connector (or equivalent) for the connector on the cable.



## RS-232C/RS-422A Protocol

A protocol is a set of rules the computer follows in sending data to the printer. The RS-232C/RS-422A parameters are stored in battery backed-up memory. They are indicated on the status printout. They can be changed by the FRPO (firmware reprogram) command described in the *Programming Manual* provided on the CD-ROM supplied with the printer. The parameters and their identification codes are given below.

### H1: Baud rate

Parameter value	Baud rate
12	1200
24	2400
48	4800
96	9600
19	19200
38	38400
57	57600
11	115200

The factory setting is 9600 baud.

### H2: Data bits

7 or 8, factory-set to 8.

### H3: Stop bits

1 or 2, factory-set to 1.

### H4: Parity

Parameter value	Meaning
0	None
1	Odd
2	Even
3	Ignore

The factory setting is "None" (0 on the status printout).

**H5: Protocol logic**

Parameter value	Meaning
0	Combination of 1 and 3 below
1	DTR/DSR, positive logic
2	DTR/DSR, negative logic
3	XON/XOFF
4	ETX/ACK
5	XON/XOFF recognized only as protocol

The factory setting is 0.

**H6: Buffer nearly-full threshold**

This is a percentage from 0 to 99. The factory setting is 90.

**H7: Buffer nearly-empty threshold**

This is a percentage from 0 to 99. The factory setting is 70.

The factory settings of the buffer nearly-full and nearly-empty thresholds (H6 and H7) are subject to change without notification.

The gap between the nearly-full and nearly-empty thresholds allows the computer to send a fairly large amount of data in a continuous stream.

**H8: Received-data buffer size**

This is the size of the input buffer, specified in units of 10 Kbytes. The factory-set value is 6, meaning 60 Kbytes.



Note

Since DTR/DSR protocol is not used with the RS-422A standard, select a parameter value other than 0, 1, or 2 for the H5 setting when using the RS-422A interface.

**PRESCRIBE FRPO D0 Command**

The PRESCRIBE FRPO D0 command provides control over XON/XOFF operation when an error occurs on the serial interface. The following table summarizes the error status corresponding to different D0 values.

		Serial interface error	
		Error not handled	Error handled
Timing of XON transfer to host while Ready or Waiting	XON sent every 3-5 seconds	D0=0 (default)	D0=1
	XON not sent	D0=10	D0=11

---

## RS-232C Cable Connection

### Obtain a Suitable RS-232C Cable

Make sure that the RS-232C cable is wired correctly. The cable must be a null modem cable; that is, one in which pin 2 on either end of the cable is connected to pin 3 on the other end. You cannot use a straight cable such as IBM communication adapter cable type 1502067 unless you purchase a null modem adapter.

### Connecting the Printer to the Computer

Check that the power of both the printer and the computer is switched off.

- 1** Discharge yourself of static electricity by touching a metal object such as a doorknob.
- 2** Remove the plastic cap from the printer's RS-232C interface connector.
- 3** Plug the printer end of the RS-232C interface cable into the printer's RS-232C connector and screw it in place.
- 4** Plug the other end of the cable into the computer's RS-232C interface connector.
- 5** Switch on the printer's power.
- 6** The printer's RS-232C parameters are factory-set to the following values:

Baud rate=9600 bps, data bits (character length)=8 bits, stop bits=1, parity=none

The two RS-232C protocols are XON/XOFF and DTR. The printer performs both of them simultaneously, using positive logic for DTR.

If you are uncertain as to the printer's current parameter settings, you can reset them to the values listed above. See [Serial Interface Parameters](#) on page 1-76.

- 7** Set the computer to the same parameters as the printer. On many computers this can be done by setting DIP switches before the power is turned on. Another method is as follows:

With Windows 95/98/Me, make settings as follows:

- 1 Click on **Start** button in the Windows 95/98/Me Task Bar and align the cursor with **Settings**, then click on **Control Panel** from among the items displayed.
- 2 The control panel folder opens. Double click on **System**.
- 3 **System Properties** opens. Click on the **Device Manager** tab, then click on the **COM** port to be used.

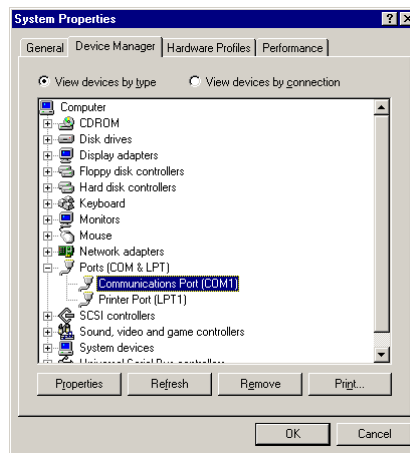

- 4 Click on **Properties** button.
- 5 The Properties sheet is displayed for the selected **COM** port. Click on the **Port Settings** tab and set the port properties.

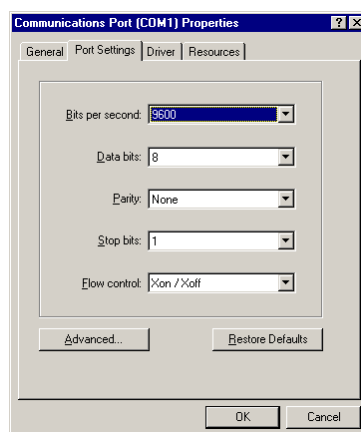

- 6 After setting the properties, click **OK** button.

In DOS, enter the following commands:

```
C:\>MODE COM1:96,N,8,1,P
```

```
C:\>MODE LPT1:=COM1
```

To test the interface, enter the following:

```
CTRL P
```

```
C:\>DIR
```

```
CTRL P
```

The software settings made using the above procedures are temporary. On most computers, permanent settings must be made with DIP switches.

---

## **Appendix D Specifications**

---

## Specifications

Item	Description
<b>Printing method</b>	Electrophotography, laser scan
<b>Printing speed</b>	18 pages/minute (A4 size) when printing multiple copies of the same page
<b>Resolution</b>	Fast 1200 mode with KIR [Kyocera Image Refinement] 600 dpi with KIR (Kyocera Image Refinement) 300 dpi with KIR (Kyocera Image Refinement)
<b>First print</b>	Approx. 19 seconds or less (A4 size), depending on input data
<b>Warm-up time</b>	Approx. 9 seconds or less (from sleep mode) Approx. 16 seconds or less (from power on) at 23 °C, 120 or 230 V
<b>Controller</b>	PowerPC 405 (200 MHz)
<b>Main memory</b>	16 MB, expandable up to 144 MB
<b>Interfaces</b>	Parallel: IEEE1284, 1 USB: Revision 1.1, 1 Option: Serial interface/Network interface card, 1
<b>Memory card slot</b>	1 (CompactFlash card)
<b>Hard disk slot</b>	1 (Microdrive)
<b>Self test</b>	Performed at power-up
<b>Maximum duty cycle</b>	65,000 pages/month
<b>Drum</b>	Amorphous silicon drum
<b>Developer</b>	Mono-component dry developer
<b>Main charger</b>	Positive scorotron charger
<b>Transferring</b>	Negative charger roller
<b>Separation</b>	Curvature separation
<b>Drum cleaning</b>	Blade cleaner
<b>Drum discharging</b>	Illumination by eraser LED array
<b>Fuser</b>	Heat roller and pressure roller
<b>Toner saving</b>	Ecoprint mode
<b>Paper</b>	Plain paper (See <a href="#">Chapter 2</a> )
<b>Paper feed trays</b>	Cassette: A5 to A4/Letter universal cassette 148 to 216 mm × 210 to 297 mm. Holds 500 sheets of thickness 0.11 mm For U. S. A.: A5 to A4/Letter and Legal universal cassette 5-13/16 to 8-1/2" × 8-1/4 to 14" MP tray: 70 to 216 mm (2-3/4 to 8-1/2") × 148 to 297 mm (5-13/16 to 11-11/16") (see page <a href="#">2-4</a> ). Holds 100 sheets of thickness 0.11 mm
<b>Capacity of output trays</b>	Face-down tray — 250 sheets of thickness 0.11 mm Face-up output tray (Option) — PT-4: 250 sheets of thickness 0.11 mm PT-60: 100 sheets of thickness 0.11 mm
<b>Ambient conditions</b>	Temperature: 10 to 32.5 °C (50 to 90.5 °F) Humidity: 20 to 80 % RH Optimum conditions: 23 °C (73.4 °F), 60 % RH Altitude: Max. 2,000 m (6,500 feet) Illumination: Max. 1,500 lux

Item	Description
<b>Power requirements</b>	120 V, 60 Hz, max. 7.2 A (U. S. A./Canada) 220–240 V, 50 Hz/60 Hz, max. 3.6 A (European countries) Max. allowable voltage fluctuation: $\pm 10\%$ Max. allowable frequency fluctuation: $\pm 2\%$ .
<b>Power consumption</b>	Max.: 961 W During sleep mode: 12 W
<b>Operating noise (in accordance with ISO 7779 [Bystander Position, sound pressure level at the front])</b>	During printing: LpA = 53 dB (A) During standby: LpA = 35 dB (A) During sleep mode: Immeasurably low
<b>Dimensions</b>	345 (13-9/16) wide $\times$ 300 (11-13/16) high $\times$ 390 mm (18-1/4") deep [(:) U. S. A.]
<b>Weight</b>	13 kg (28-5/8 lb), main unit only



---

# Glossary

---

### **Cassette mode**

This is an operation mode for the MP tray. When this mode is used, approximately 100 sheets of plain paper can be fed continuously, the same as for the cassette.

### **dpi (dots per inch)**

This indicates the number of dots printed per inch, and is the unit of printer resolution.

### **Ecoprint**

This is a printing mode that controls toner consumption. Pages printed in the Ecoprint mode are lighter than pages printed in the normal mode. The default setting is Off.

### **Emulation**

This refers to emulation of manufacturers' printers. The printer emulates operation of the following printers: PCL, Line printer, IBM Proprinter, DIABLO 630, EPSON LQ-850, KPDL.

### **Expansion memory**

This option is used to increase printer memory. The printer has an expansion socket, into which you can install a 16 MB, 32 MB, 64 MB, or 128 MB DIMM (Dual Inline Memory Module). See your Kyocera Mita dealer to purchase the DIMM that is best suited for use with this printer.

### **Face-up output tray**

Tray installed at the rear of the printer. Select paper output to the face-up output tray when printing on postcards, envelopes, or labels.

### **First mode**

This is an operation mode for the MP tray. When the MP tray setting is set to first mode (priority printing from the MP tray) with paper inserted in the MP tray, the first paper will always feed from there even if another paper source is selected. The printer is set to the cassette mode (another MP tray operation mode) as the factory default, but you can change this setting from the operator panel.

### **IEEE1284**

This is a standard used when connecting a printer to a computer, and was established by the Institute of Electrical and Electronic Engineers in 1994.

### **KIR (Kyocera Image Refinement)**

This is Kyocera's original smoothing function. It uses software to enhance the printer's resolution and produce high-quality printing. The default setting is On.

### **KM-NET VIEWER**

This is a network management tool that can be used with the Kyocera Mita FS series. You can view information for printers connected to the network using SNMP commands. **KM-NET VIEWER** is contained on the *Kyocera Mita Digital Library* CD-ROM supplied with the printer.

### **Kyocera Mita Digital Library**

This is contained on the CD-ROM supplied with the printer. The contents of the CD-ROM include guides, printer drivers, and various utilities.

### **MB (mega byte)**

This unit is used to express data quantities and memory capacities. 1 MB is equivalent to 1024 kB, or 1,048,576 bytes.

## MP tray

This is an abbreviation for Multi-Purpose tray. The MP tray is used instead of the cassette when printing on envelopes, postcards, transparency sheets, and labels.

## Offline

The printer can receive data, but cannot print. Turn the printer online if you want to print.

## Online

The printer can output received data.

## Operator panel

This is located on the top of the printer. The panel consists of the message display three indicators and eight keys. The message display shows the printer's status. Press the keys when you want to switch the printer between online and offline status, or to cancel printing.

## Outline font

With outline fonts, characters outlines are represented by numerical expressions, and fonts can be enlarged, reduced, or painted in different ways by changing the numeric values of those expressions. Printing remains clear even if you enlarge fonts, since the letters are defined by an outline. You can specify font size in steps of 0.25 points up to 999.75 points.

## Parallel interface

With this interface, data transfer between the printer and the computer takes place on 8-bit chunks. The printer can perform IEEE1284 compatible bi-directional communications.

## Printer driver

The printer driver makes it possible for you to print data created using application software. The printer driver for either the printer is on the *Kyocera Mita Digital Library* CD-ROM supplied with the printer. Install the printer driver on the computer connected to the printer.

## RAM disk

This is a virtual disk drive that uses part of the printer's memory. With RAM disk you can set any memory size arbitrarily, and use electronic sorting (to reduce print time).

## Simple Network Management Protocol (SNMP)

This is a protocol for the management of networks that use TCP/IP (Transmission Control Protocol/Internet Protocol).

## Sleep mode

This mode is activated after a specified amount of time elapses. The printer goes into economy mode and a minimum amount of power is consumed. You can change the amount of time before the printer goes into sleep mode from the printer's operator panel. The default setting is 15 minutes.

## Status page

This lists printer conditions, such as the printer's memory, the total number of copies printed, and paper source settings.

## USB (Universal Serial Bus)

An interface standard for low to middle speed serial interfaces. This printer supports USB revision 1.1. The maximum transfer rate is 12 Mbps and the maximum cable length is 5 meters (16 feet).

---

# Index

---

---

## A

Adhesive label 2-8  
Alarm (Buzzer) setting 1-104  
Amorphous silicon drum *viii*  
Auto continue 1-105

## C

Cassette size 1-24  
Charger unit 3-11  
Cleaning 3-9  
    charger wire 3-9  
    grid cleaner 3-10  
    paper transfer unit 3-12  
Cleaning knob 3-9  
Code job 1-67, 1-72  
CompactFlash card *ix*, 1-81, B-2, B-30

## D

Developer unit 4-3  
DIMM B-4  
Duplexer (DU-60) 4-16, B-12

## E

Ecoprint *viii*, 1-54  
e-MPS 1-56, 1-70  
Emulation 1-16, 1-41, *Glossary-2*  
Envelope feeder (EF-60) B-21  
Envelopes 2-9  
Error messages 4-10  
Expansion memory *Glossary-2*

## F

Face-up output tray (PT-4/  
PT-60) B-25, *Glossary-2*  
Font A-1  
Font lists 1-21

## G

Grid cleaner 3-2, 3-10

## I

IB-10E B-2, C-6  
Indicators 1-4, 4-6  
Interface *viii*, 1-3, C-1  
Internal font A-2

## J

Job retention *ix*

## K

Keys 1-5  
KIR 1-17, 1-52  
KM-NET VIEWER *ix*, *Glossary-2*  
Kyocera Mita Digital Library *ix*, *Glossary-2*

## L

Left cover 3-6, 3-9

## M

Main circuit board B-4, B-28  
Maintenance messages 4-7  
Memory expansion B-4  
Menu map 1-12  
Menu system road map 1-6  
Message display 1-2  
Message language 1-97  
Microdrive 1-81, B-2, B-28  
MP tray 1-24  
    cassette mode 1-37, *Glossary-2*  
    first mode 1-37, *Glossary-2*  
    paper guides 1-25

## N

Network *ix*, 1-3, 1-78  
Network interface card 1-19, B-2  
    status page 1-19

## O

Online help messages 1-5, 4-13  
Operator panel 1-2, *Glossary-3*  
    indicators 1-4  
    INTERFACE indicator 1-3  
    message display 1-2  
    SIZE indicator 1-3  
    TYPE indicator 1-4  
Options B-2  
Orientation 1-51

## P

Paper 2-1  
    adhesive labels 2-8

---

colored paper 2-9  
condition 2-3  
envelope 2-9  
grain 2-6  
preprinted paper 2-9  
recycled paper 2-10  
size 2-4  
special paper 2-7  
specifications 2-2  
thickness 2-5  
type 2-7  
weight 2-4  
Paper cassette 1-3, B-9  
  clip B-11  
  load limit B-11  
Paper feeder (PF-60) B-9  
Paper guide 1-25  
Paper jam 4-12  
Paper size dial 1-24, 1-25, B-10  
Paper size window 1-24  
Paper stopper 1-25, B-10, B-25  
Paper transfer unit release lever 3-12  
Parallel interface 1-3, 1-74, C-2, *Glossary-3*  
  bi-directional/high-speed *viii*  
  communication modes C-2  
  pin assignment C-3  
PDF417 *ix, x*  
Plastic bag 3-2  
PRESCRIBE command *ix, x, C-10*  
PRESCRIBE Programming Manual *x*  
Print density 1-95  
Print quality 4-3  
Printer driver 1-6, B-8, *Glossary-3*  
Printer drivers guide *x*  
Protocol 1-76, C-9

## R

RAM disk 1-81, *Glossary-3*  
Recycled paper 2-10  
Registration roller 3-13, 4-15  
Resolution 1-55  
Resource protection 1-103  
RS-232C 1-76, C-6, C-9, C-11  
RS-422A C-7, C-9

## S

Serial interface 1-76, C-6  
  protocol 1-76, C-9  
  RS-232C mode C-6  
  RS-422A mode C-7

Serial interface board kit (IB-10E) B-2, C-6  
Service status page 1-18  
Simple Network Management Protocol  
  (SNMP) *ix, Glossary-3*  
Sleep mode *viii, 1-2, 1-100, Glossary-3*  
Sleep timer 1-2, 1-100  
Sorter (SO-60) 4-18, B-15  
Specifications D-1  
Status page 1-14

## T

TK-50 3-2  
Toner container 3-2  
  dispose 3-3  
  grid cleaner 3-10  
  lock lever 3-3  
  protective seal 3-4  
  replacement 3-2  
Toner gauge 1-16, 1-96  
Toner kit 3-2  
Top cover 3-3  
Troubleshooting  
  error messages 4-10  
  indicators 4-6  
  interface 4-2  
  maintenance messages 4-7  
  quality problems 4-3  
Two-dimensional bar code (PDF417) *ix, x*  
Typeface A-1

## U

USB interface *viii, 1-3, 1-75, C-5, Glossary-3*

## V

Virtual Mailbox (VMB) 1-68

## W

Waste toner box 3-2, 3-6  
Windows C-12  
Wiper cloth 3-2, 3-13







# Printer Driver Guide

for FS-1900

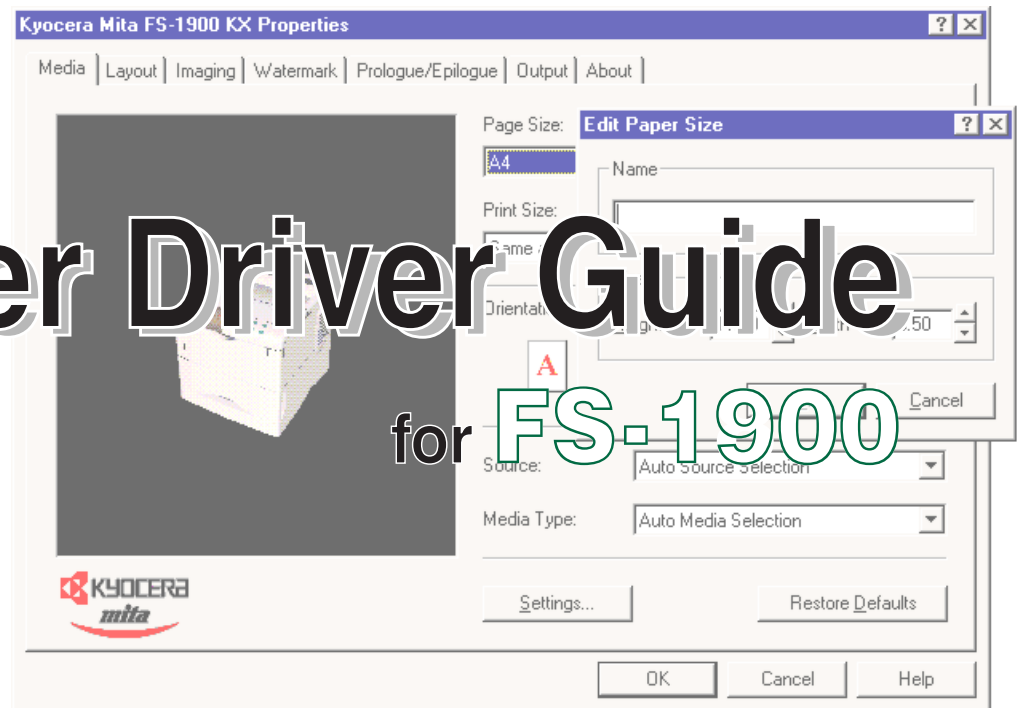



---

## Notice

---

The information in this guide is subject to change without notification. Additional pages may be inserted in future editions. The user is asked to excuse any technical inaccuracies or typographical errors in the present edition.

No responsibility is assumed if accidents occur while the user is following the instructions in this guide. No responsibility is assumed for defects in the printer's firmware (contents of its read-only memory).

This guide, any copyrightable subject matter sold or provided with or in connection with the sale of the page printer, are protected by copyright. All rights are reserved. Copying or other reproduction of all or part of this guide, any copyrightable subject matter without the prior written consent of Kyocera Corporation is prohibited. Any copies made of all or part of this guide, any copyrightable subject must contain the same copyright notice as the material from which the copying is done.

## Regarding Tradenames

---

Microsoft, and Windows are registered trademarks of Microsoft Corporation. PCL is a registered trademark of Hewlett-Packard Company. PostScript is a registered trademark of Adobe Systems Incorporated. Microdrive is trademark of International Business Machines Corporation. CompactFlash is a trademark of SanDisk Corporation. All other brand and product names are registered trademarks or trademarks of their respective companies.

---

## Preface

This guide contains information on how to install, configure, and use the printer drivers for the Kyocera Mita FS-1900 printer. The printer drivers and other utility software are supplied on the **Kyocera Mita Digital Library CD-ROM**, other additional CD-ROM, and from the Internet. The driver CD-ROM's is included with the printer.

The CD-ROM's supports different printer drivers for the following operating systems:

- Microsoft Windows 95, Windows 98, and Windows Me
- Microsoft Windows NT 4.0, and Windows 2000
- Apple Macintosh OS 7 or greater
- IBM OS/2 Version 2.0 or greater
- Linux

The guide focuses on using the printer driver on Windows Me.

The latest Kyocera Mita printer drivers and utilities are readily available at the following web site:

<http://www.kyocera.com/w2k>.



Note

**For improvement purpose, the user interface design and functionalities of the printer driver may vary depending on the version. The diagrams used throughout this guide are only for examples.**

---

# Contents

<b>Chapter 1 Installing the Printer Driver.....</b>	<b>1-1</b>
Using Parallel Interface.....	1-1
Using USB Interface .....	1-8
<b>Chapter 2 Adding Optional Devices .....</b>	<b>2-1</b>
Installing the Paper Feeder (PF-60).....	2-1
Installing the Duplexer (DU-60).....	2-3
Installing the Sorter (SO-60) .....	2-4
Installing the Envelope Feeder (EF-60).....	2-5
Installing the Microdrive (Hard Disk) .....	2-6
Selecting the Printer Description Language and Entering User Name .....	2-7
<b>Chapter 3 Printing from Windows Applications.....</b>	<b>3-1</b>
Basic Printing Task.....	3-1
Setting Custom Paper Size.....	3-3
Advanced Media Settings .....	3-5
Cover Mode.....	3-5
Page Insert .....	3-8
Transparency Interleaving .....	3-10
Printing Multiple Pages per Sheet.....	3-12
Changing the Size of the Document.....	3-13
Changing the Resolution.....	3-14
Adjusting Grayscale .....	3-15
TrueType Fonts .....	3-16
Watermark Printing.....	3-17
Using the Duplexer (DU-60) .....	3-19
Using the Sorter (SO-60).....	3-21
e-MPS.....	3-24
Using Job Retention.....	3-26
Quick Copy Printing .....	3-26
Proof and Hold Printing .....	3-28
Private Printing .....	3-30
Stored Job Printing (Job Storage).....	3-32
Virtual Mailbox Printing .....	3-34
Printing a Code Job.....	3-39

## Chapter 1 Installing the Printer Driver



Note

If you want to use the printer as a USB printer, you should install the USB device driver first. See [Using USB Interface](#) on page 1-8 for instruction.

### Using Parallel Interface

When you insert the **Kyocera Mita Digital Library** CD-ROM supplied with the printer into your computer, the setup screen is automatically displayed. To install the printer driver, follow the on-screen instructions.

- 1 Set the **Kyocera Mita Digital Library** CD-ROM in your computer's CD-ROM drive.

After a few moments, the **License Agreement** window opens.



Note

If this screen does not appear, click the **Windows Start** button and select **Run**. Type the following in the **Command Line** text box:

```
[CD drive letter]:\setup
```

Click the **OK** button. After a few moments, the **License Agreement** window appears.

- 2 Click **View License Agreement**. The License Agreement PDF opens. Read the terms and conditions.



If you do not have Adobe Acrobat Reader installed on your computer, the following dialog box will open. Click the **Yes** button and install it.

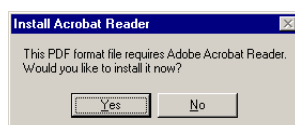

- 3 Close the **License Agreement PDF**. On the previous **License Agreement** window, click **Accept** to accept the agreement. After a few moments, the **Main Menu** appears.
- 4 Click **Install Drivers**. The **Kyocera Mita Setup Wizard** begins. Click the **Next** button.

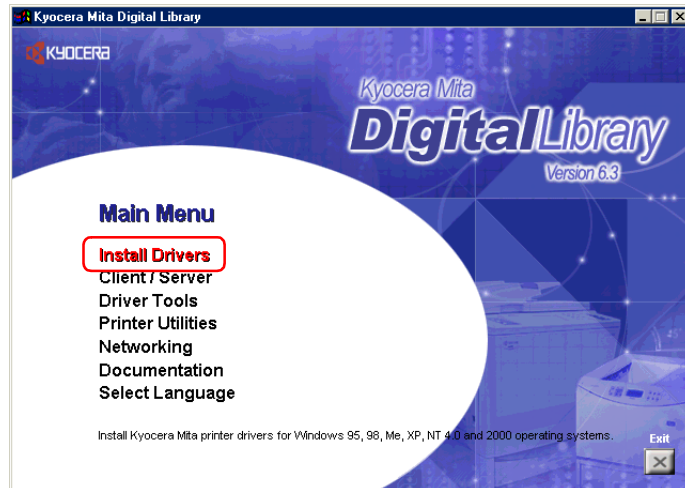

- 5 In the **Select a device model** window, click **FS-1900**.

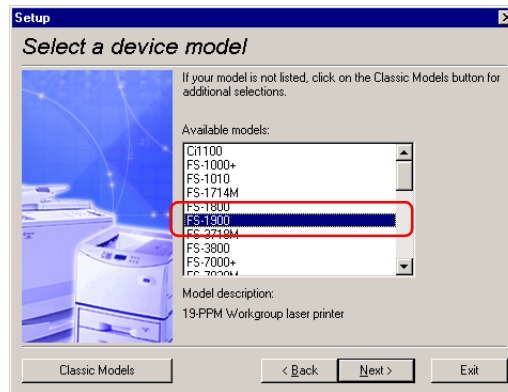

Click the **Next** button.

- 6** In the **Select a driver language** window, click the language you want.

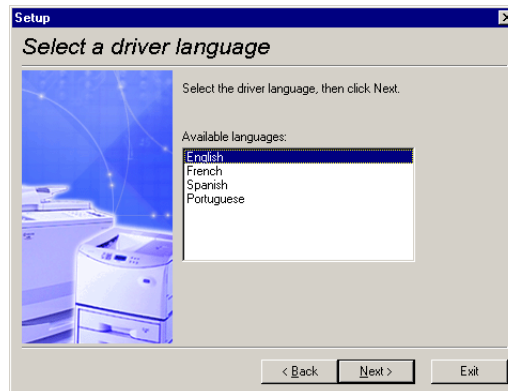

Click the **Next** button.

- 7** **Kyocera Mita FS-1900 KX** is highlighted in the **Available drivers** list box.

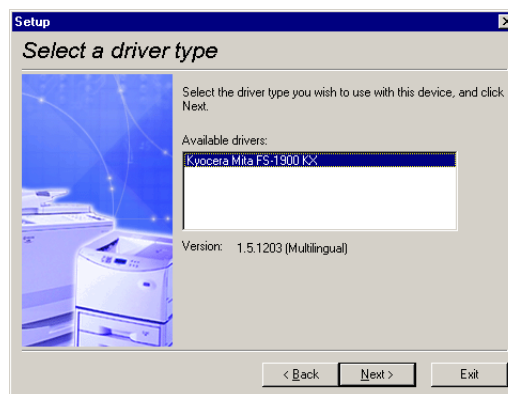

Click the **Next** button.

- 8** In this window, you can choose whether you want to install **TrueType screen fonts** and/or **Prologue/Epilogue** tab. Click the appropriate option(s).

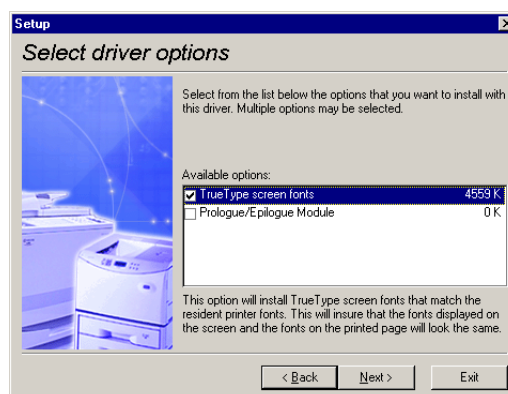

Click the **Next** button.

**9** In the **Device connection** window, select the type of connection between the printer and your computer.

If you want to connect to a network, contact your network administrator.

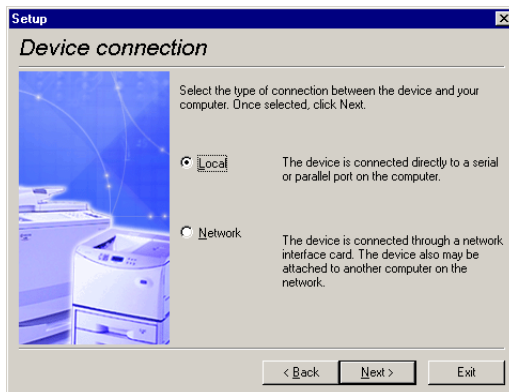

Click the **Next** button.

**10** In the **Select a device port** window, select the interface you want to use for connecting to the printer.

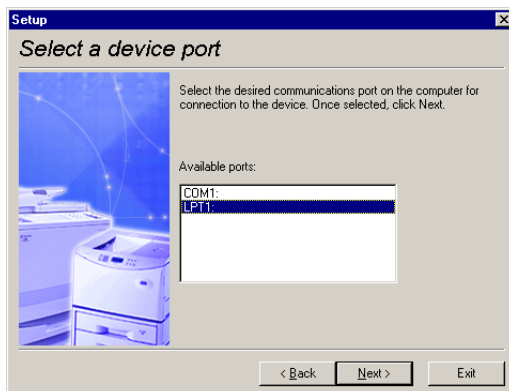

Click the **Next** button.

- 11** In the **Select a device name** window, enter a unique name for the printer, if desired.

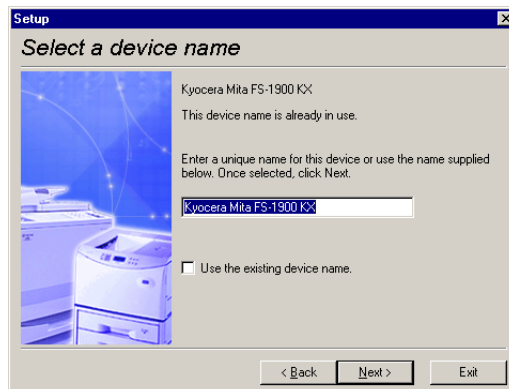

Click the **Next** button.

- 12** If you want to use the printer as the default printer, click the **Yes** button.

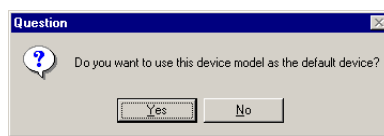

- 13** In the **Begin installation** window, click the **Next** button.

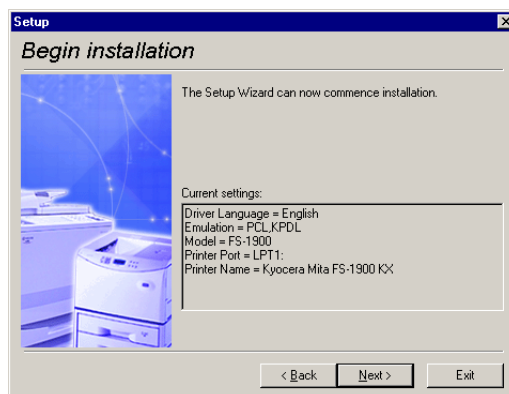



**14** Click the **Finish** button to restart the computer.

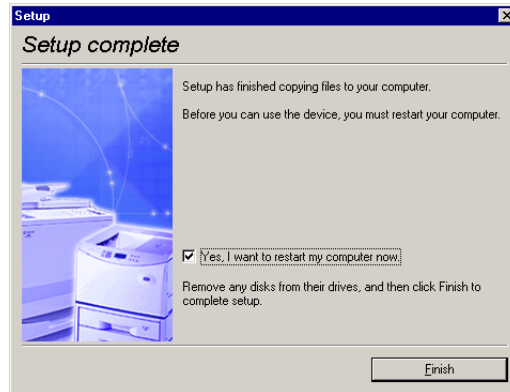

**Confirming the Installation**

After you restart the printer, follow the instructions below to make sure if the printer driver has been installed correctly.

**1** Click the Windows **Start** button, point **Setting**, and click **Printers** to make sure the **Kyocera Mita FS-1900 KX** icon has been added to the **Printers** window.

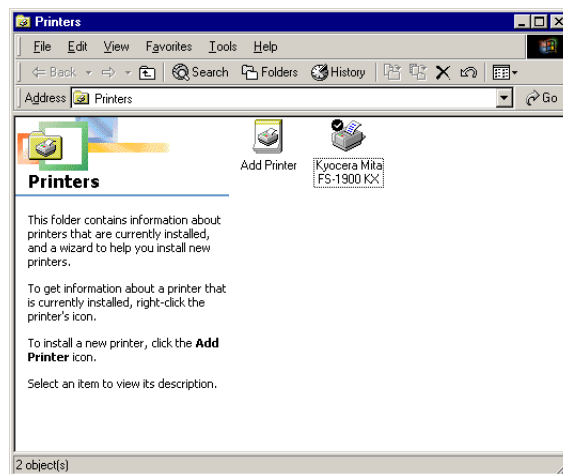

- 2** Right click the **Kyocera Mita FS-1900 KX** icon and select **Properties**. The following dialog will open. Click the **Details** tab to make sure the port you have selected in **step 11** on page **1-5** is shown in the **Print to the following port list**.

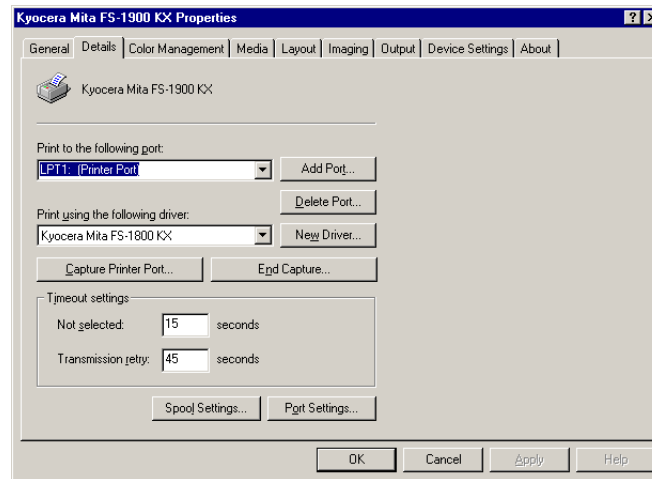

Click the **OK** button to close the window. Proceed to **Adding Optional Devices** on page **2-1** to make default settings.

## Using USB Interface

You can print to the printer's USB connector if Windows 98/Me or Windows 2000 is running on your computer. You need to connect the printer to your computer using a USB cable.

### Installing the USB Printing Support

This section explains you how to install the **USB Printing Support** as well as the printer driver onto your Windows Me computer. If you are using Windows 98 or 2000, you can use the similar procedure. Follow the instructions displayed on the screen.

- 1 Turn on the computer and the printer, then insert the **Kyocera Mita Digital Library** CD-ROM into the computer's CD-ROM drive
- 2 Connect the printer and the computer using a USB cable.
- 3 The Windows Plug and Play function will detect the printer automatically and the **Add New Hardware Wizard** will open. Select **Automatic search for a better driver**.



Click the **Next** button.

- 4 The following dialog box will open when the installation has been completed. The above completes installing the **USB Printing Support**. Proceed to the next section.



Click the **Finish** button.

## Installing the Printer Driver for USB

- 1 Subsequently the installation of the printer driver will begin. Select **Automatic search for a better driver.**

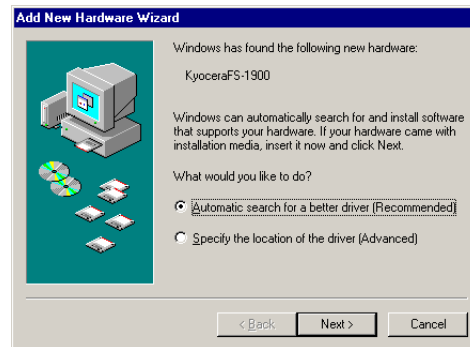

Click the **Next** button.

- 2 Select the printer driver to be used. Normally, select the **Kyocera Mita FS-1900KX** driver displayed at the lower part.

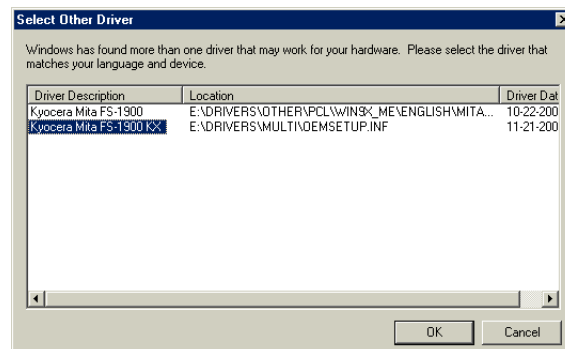

Click the **OK** button.

- 3 **Add Printer Wizard** will open. Follow the instructions shown on the wizard and complete the installation of the printer driver.

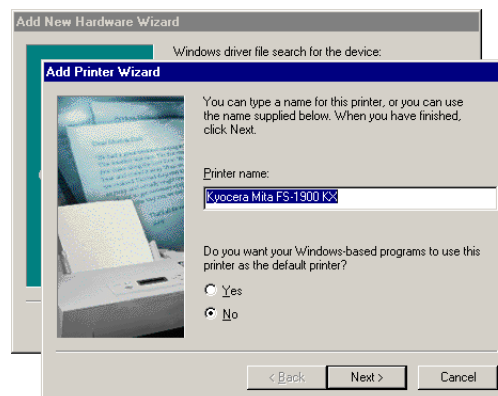

- 4** Click the Windows **Start** button, point **Setting**, and click **Printers** to make sure the **Kyocera Mita FS-1900 KX** icon has been added to the **Printers** window.



- 5** Right click the **Kyocera Mita FS-1900 KX** icon and select **Properties**. The following dialog will open. Click the **Details** tab to make sure **USB 001 (Virtual printer port for USB)** is selected for the **Print to the following port list**.

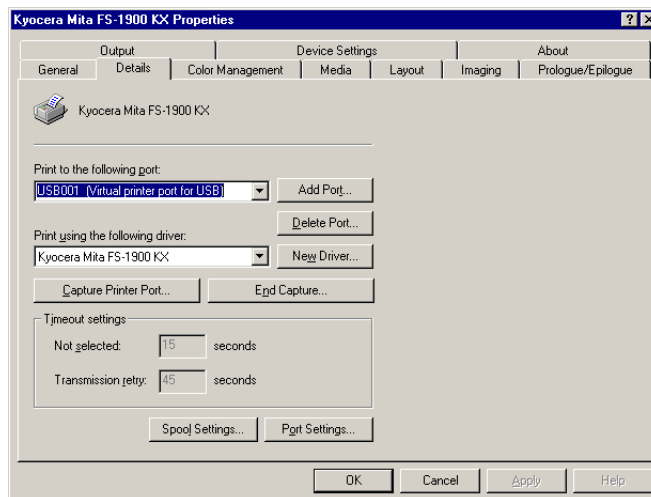

Click the **OK** button to close the window. Proceed to the next section.

## Chapter 2 Adding Optional Devices

This section explains how to set defaults on option units installed on the printer. Setting made in this way will become effective for all application software. To temporarily change the settings, make printer settings from the application. See [Chapter 3, Printing from Windows Applications](#).

The printer driver online help will describe the printer settings in more detail.

The **Device Settings** tab enables you to setup optional devices such as paper feeders so that the printer can recognize them. Each printer has a unique set of options that are listed in the **Device Settings** window. If you have attached one or more printer options, check that option.

### Installing the Paper Feeder (PF-60)

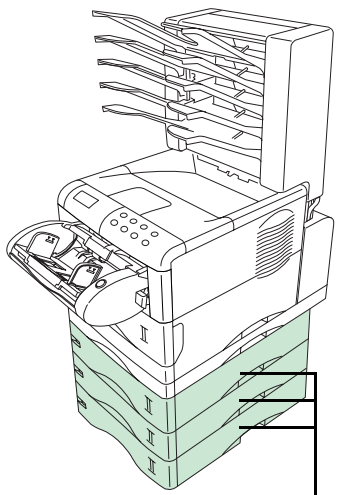

Paper Feeder

Check that the option paper feeder (PF-60) is installed on the printer correctly.

- 1 Browse through Windows **Start > Settings > Printers**.
- 2 Right click on the **Kyocera Mita FS-1900 KX** icon and then click **Properties**.

The **Properties** dialog box is displayed.

- 3 Click the **Device Settings** tab.

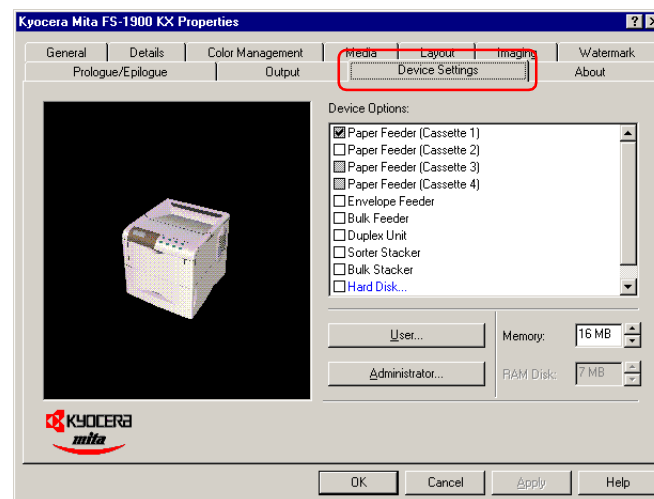

- 4** Check **Paper Feeder** in the **Device Options** list box. **Paper Feeder (Cassette 1)** is the standard printer cassette. If three optional paper feeders have been installed, check **Paper Feeder (Cassette 2)**, **Paper Feeder (Cassette 3)**, and **Paper Feeder (Cassette 4)** sequentially.

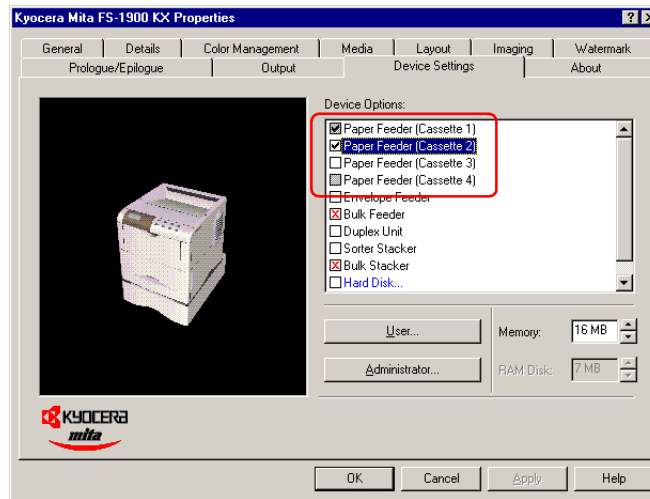

- 5** Click the **OK** button.

## Installing the Duplexer (DU-60)

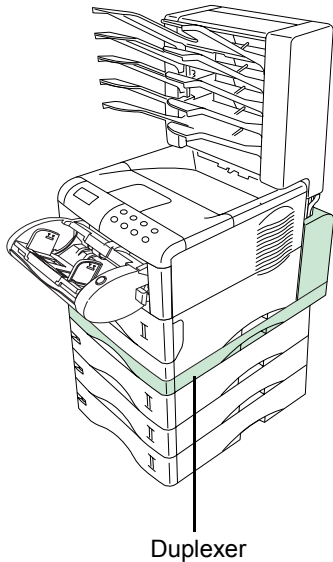

Check that the option duplexer (DU-60) is installed on the printer correctly.

- 1 Browse through Windows **Start > Settings > Printers**.
- 2 Right click on the **Kyocera Mita FS-1900 KX** icon and then click **Properties**.

The **Properties** dialog box is displayed.

- 3 Click the **Device Settings** tab.

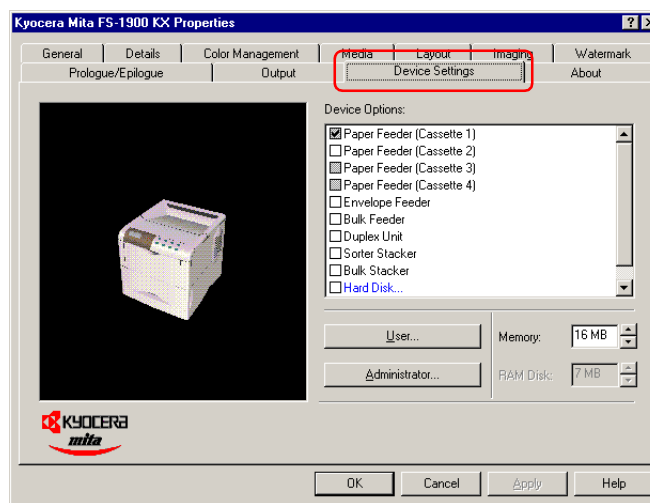

- 4 Click **Duplex Unit** in the **Device Options** list box.

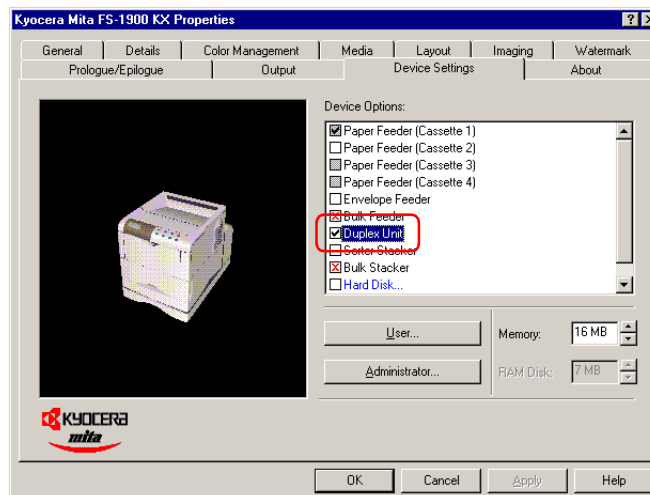

- 5 Click the **OK** button.



### Installing the Sorter (SO-60)

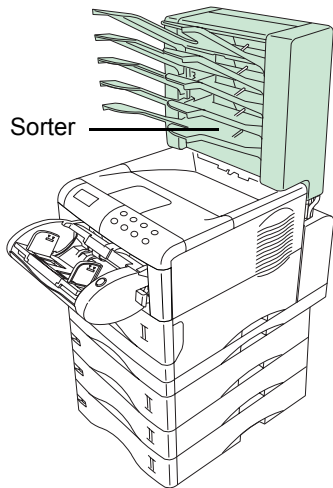

Check that the option sorter (SO-60) is installed on the printer correctly.

- 1 Browse through Windows **Start > Settings > Printers**.
- 2 Right click on the **Kyocera Mita FS-1900 KX** icon and then click **Properties**.

The **Properties** dialog box is displayed.

- 3 Click the **Device Settings** tab.

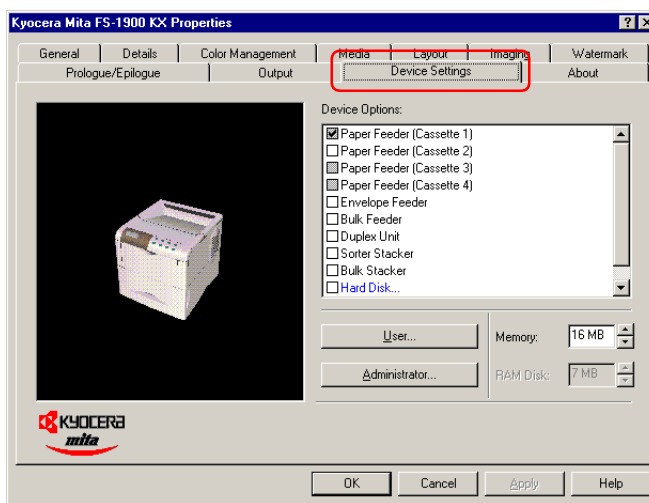

- 4 Click **Sorter Stacker** in the **Device Options** list box.

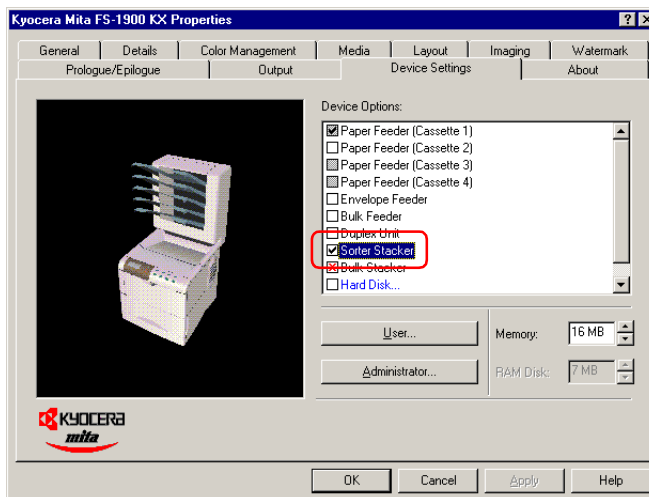

- 5 Click the **OK** button.

## Installing the Envelope Feeder (EF-60)

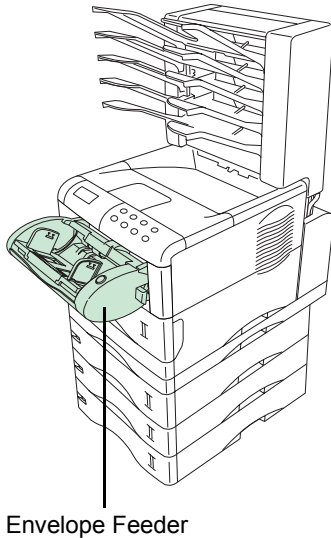

Check that the option envelope feeder (EF-60) is installed on the printer correctly.

- 1 Browse through Windows **Start > Settings > Printers**.
- 2 Right click on the **Kyocera Mita FS-1900 KX** icon and then click **Properties**.

The **Properties** dialog box is displayed.

- 3 Click the **Device Settings** tab.

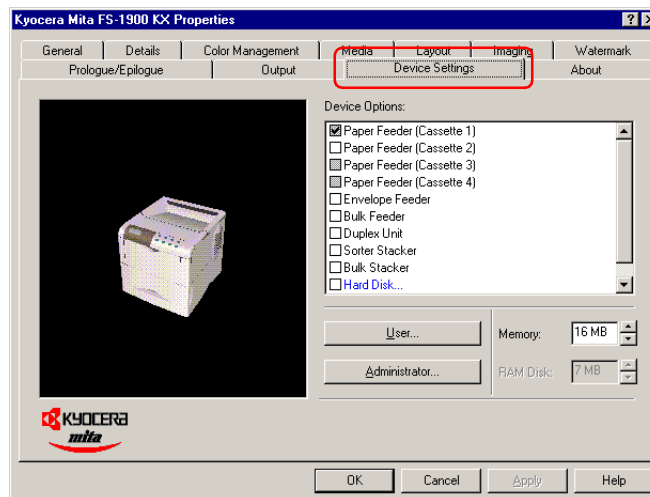

- 4 Click **Envelope Feeder** in the **Device Options** list box.

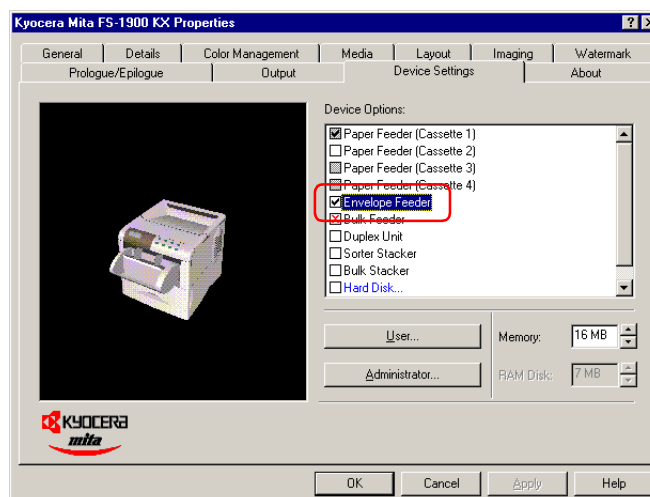

- 5 Click the **OK** button.

## Installing the Microdrive (Hard Disk)

For details of available Microdrives, see your dealer. Check that the option Microdrive is installed in the printer correctly.

**1** Browse through Windows **Start > Settings > Printers**.

**2** Right click on the **Kyocera Mita FS-1900 KX** icon and then click **Properties**.

The **Properties** dialog box is displayed.

**3** Click the **Device Settings** tab.

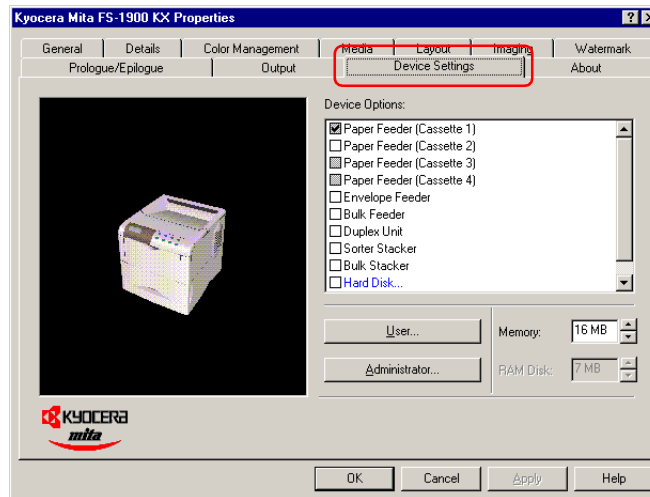

**4** Click **Hard Disk** in the **Device Options** list box.

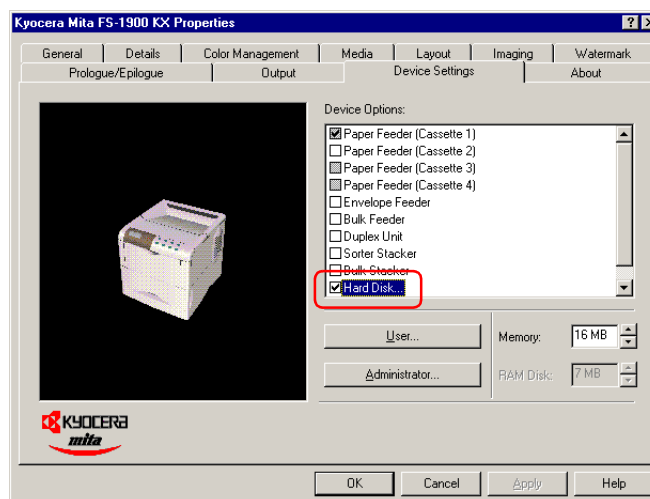

**5** Click the **OK** button.

## Selecting the Printer Description Language and Entering User Name

Select the printer description language adequate for the data to be printed from among PCL XL, PCL 5e and KPD (PostScript compatible). When using the virtual mailbox function, select PCL XL or PCL 5e. The default setting is PCL XL.

- 1 Browse through Windows **Start > Settings > Printers**.
- 2 Right click on the **Kyocera Mita FS-1900 KX** icon and then click **Properties**.

The **Properties** dialog box is displayed.

- 3 Click the **Device Settings** tab.

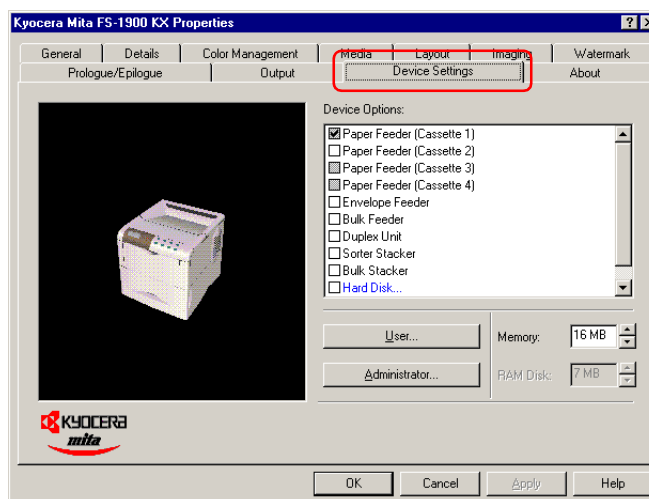

**4** Click the **User** button. The **User Settings** dialog box is displayed.

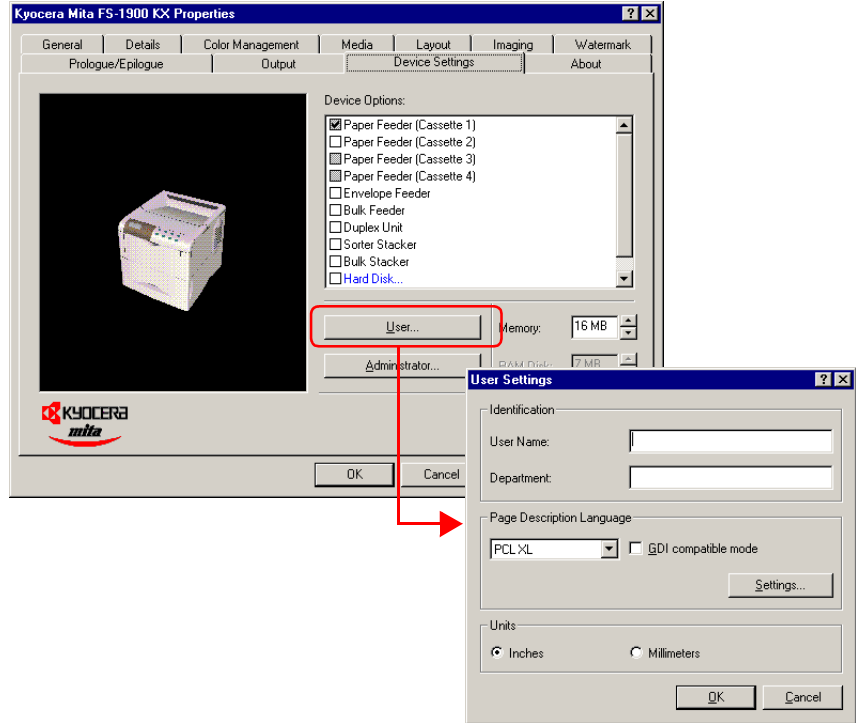

**5** Select **PCL XL**, **PCL 5e**, or **KPDL** in the **Page Description Language** drop down list, and click the **OK** button.

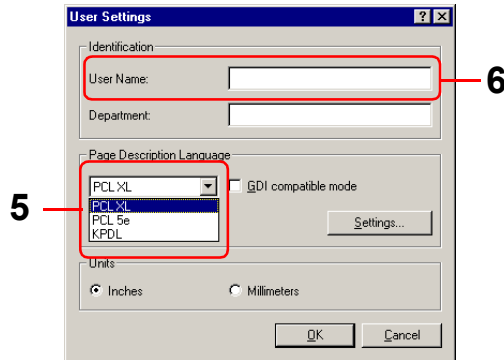

**6** Enter the user name in **User Name**. This name is used to identify your print job on the printer operator panel as part of job retention function. For details, see *e-MPS* on page 1-56 in the *Operation Guide*.

**7** Click the **OK** button.

## Chapter 3 Printing from Windows Applications

This section will discuss how to print from Windows applications using a Microsoft Word document as an example.

### Basic Printing Task

This section will explain only the minimum task that is required to print from Windows applications. You can select various options in the printer's **Properties** dialog box to customize your print job as explained in section [Setting Custom Paper Size](#) on page 3-3 and later.

- 1 Set the paper of the size specified in the application for the document into the printer's paper cassette. For details on how to set paper, refer to the [Installation Guide](#).



Note

Using the operator panel, make sure if each paper source has paper of the proper size. If not, set the appropriate paper into the source (see [Setting the Paper Size in Paper Cassette](#) on page 1-24 in the [Operation Guide](#)). If they have different paper, the output may not be printed correctly.

- 2 Open the document you want to print. The following example shows how to print a Word document.
- 3 Select **Print** from the **File** menu of Word. The **Print** dialog box will appear.

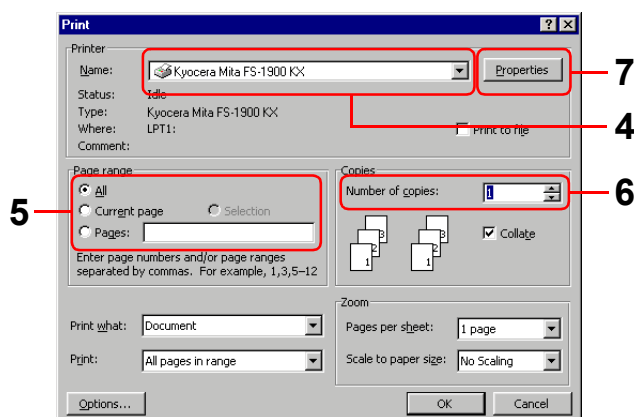

- 4 From the **Name** drop down list, select **Kyocera Mita FS-1900 KX** printer if it is not selected.
- 5 Enter the page range of the document you want to print. To print the whole document, select **All**.
- 6 Enter the number of copies, 1 to 999, you want to print in the **Number of Copies** combo box.

- 7 Click the **Properties** button. The **Properties** dialog box opens.
- 8 On the **Media** tab, select the paper size that matches the paper size of the document from the **Page Size** drop down list. The printer will automatically switch to the paper source (the paper cassette, MP tray, or the option paper feeder, if installed) so that the correct paper will be used.

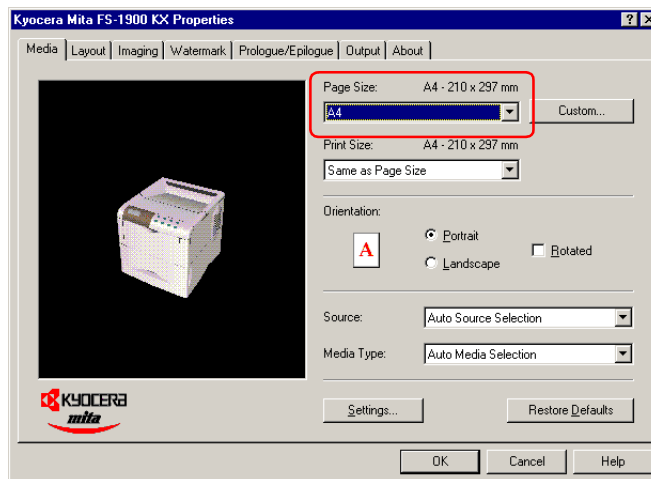

- 9 Click the **OK** button to close the **Properties** dialog box and return to the **Print** dialog box.
- 10 Click the **OK** button to start printing.

## Setting Custom Paper Size

This printer can feed non-standard size of paper. The paper cassette can accommodate paper whose sizes are ranging from 148 to 216 mm in width and 210 to 297 mm in length as well as Legal size. Note the MP tray can accommodate paper whose sizes are ranging from 70 to 216 mm in width and 148 to 297 mm in length.

### To set the custom size

- 1 Display the printer driver's **Properties** dialog box from the printer's properties dialog box. Browse through Windows **Start > Settings > Printers** > right click on the **Kyocera Mita FS-1900 KX** icon > click **Properties** > click the **Media** tab.
- 2 Click the **Custom** button on the **Media** tab. The **Custom Paper Sizes** dialog box appears.

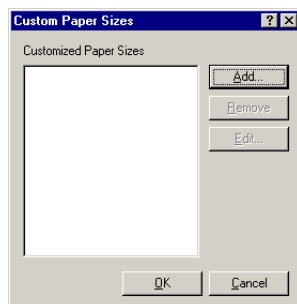

- 3 Click the **Add** button. The Edit Paper Size dialog box appears.

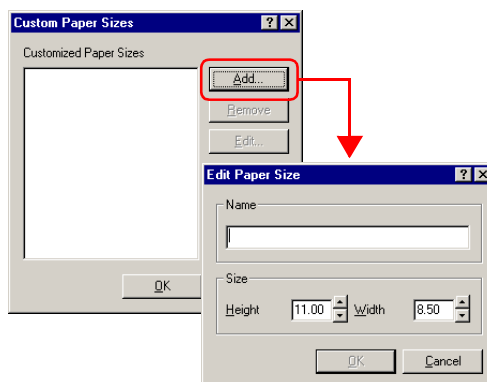

- 4 Enter a descriptive name for the custom size in **Name**.



- 5 Enter the height and width of the custom size in **Size**.

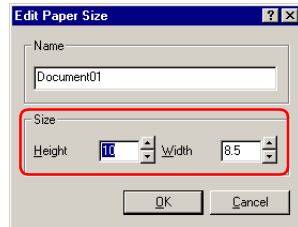

Note

You can select the unit of measurement; inches or millimeters, on the **User Settings** dialog box to be accessed by clicking the **User** button on the **Device Settings** tab.

- 6 Click the **OK** button. The custom paper size is added to the **Customized Paper Sizes** list.
- 7 Click the **OK** button. The **Media** tab is displayed again.
- 8 Select the **Custom Size** from the **Page Size** drop down list.

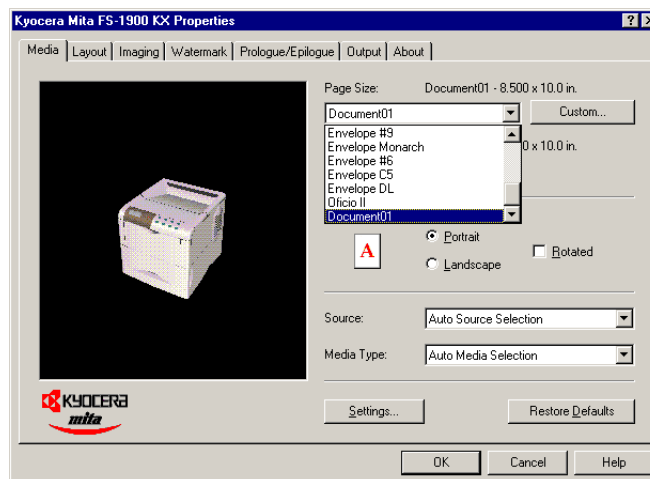

- 9 Click the **OK** button again to return to the **Print** dialog box.
- 10 Click the **OK** button to start printing.

## Advanced Media Settings

Making the **Advanced Media** settings allows you to activate the following advanced printer functions.

- **Cover mode:** Adds the front cover and/or the back cover to the document.
- **Page insert:** Inserts a blank or printed page before any page(s) of the document.
- **Transparency interleaving:** Inserts a blank or printed page between the transparencies to be printed.

These functions are explained on the following pages.

### Cover Mode

In the Cover mode, the first cover page, or the first and back cover pages of a document will be added to the document using the different paper from the paper used for the body of the document. The rest of the document will be printed on the paper specified in the **Media** tab. This will allow you to add the covers of the document using special paper, for example thick paper or colored paper, so that the printed document looks more professional.

You can also print the first page of the document on the front cover by checking **Print Outside Cover**.



Note

**Cover Mode can be used with Page Insert but not with Transparency Interleaving.**

To print the cover pages on the different paper.

- 1 Display the printer driver's **Properties** dialog box from the application software.
- 2 Click the **Settings** button on the **Media** tab. The **Advanced Media Settings** dialog box opens.

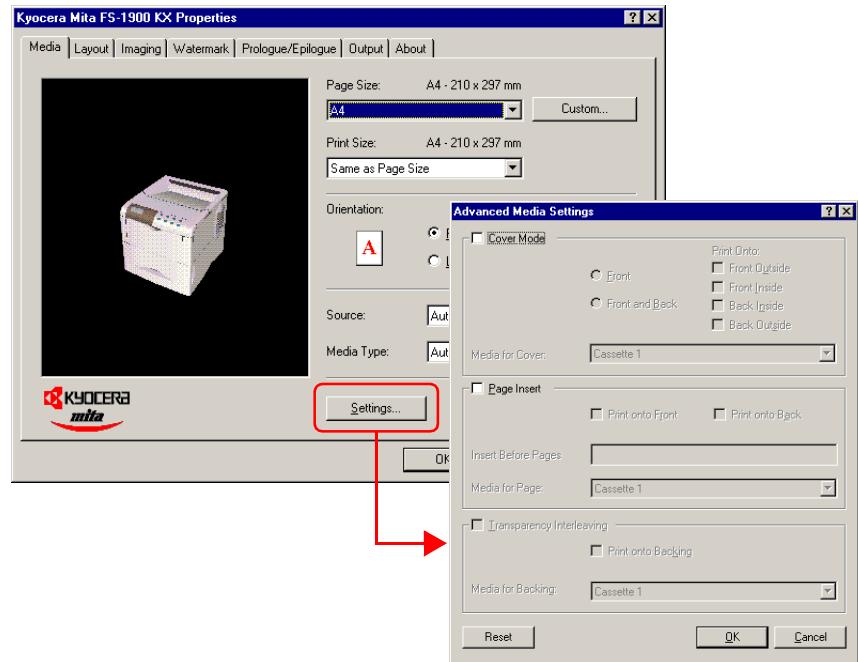

- 3 Click the **Cover Mode** check box.

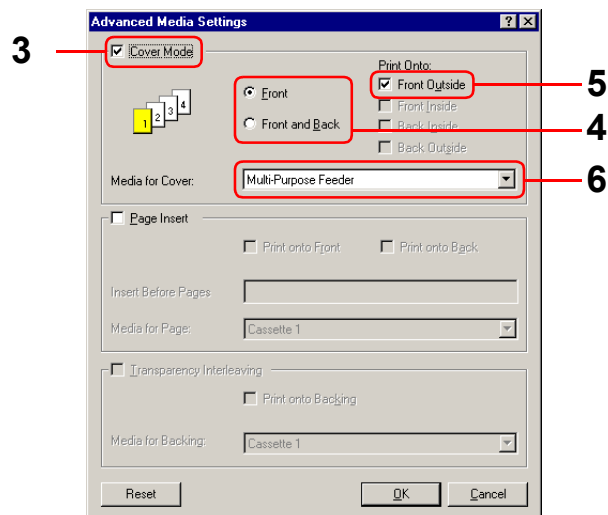

- 4 To add only the front cover using different paper, click **Front**, or to add both the front and back covers using different paper, click **Front and Back**.

- 5** To print the first page on the cover, click the **Front Outside** check box. Note that the **Front Inside**, **Back Inside**, and **Back Outside** are not applicable for model FS-1900.
- 6** Select the paper source for the cover(s) from the **Media for Cover** list box. Note that thick paper, colored paper, etc., should be loaded on the MP tray.
- 7** Click the **OK** button. The **Media** tab is displayed again.
- 8** Click the **OK** button to return to the **Print** dialog box.
- 9** Load the paper you want to use for the cover(s) onto the paper source specified in *step 6*.
- 10** Click the **OK** button to start printing.

## Page Insert

With **Page Insert**, the printer inserts a blank or printed page before any page(s) of the document that you specify. This function will allow you to insert a page that can be used to clearly separate a chapter, etc., from the previous chapter.

It is also possible to print the chapter cover page on the separate sheet.



**Page Insert can be used with Cover Mode but not with Transparency Interleaving.**

To include a separator sheet in the document.

- 1 Display the printer driver's **Properties** dialog box from the application software.
- 2 Click the **Settings** button on the **Media** tab. The **Advanced Media Settings** dialog box opens.

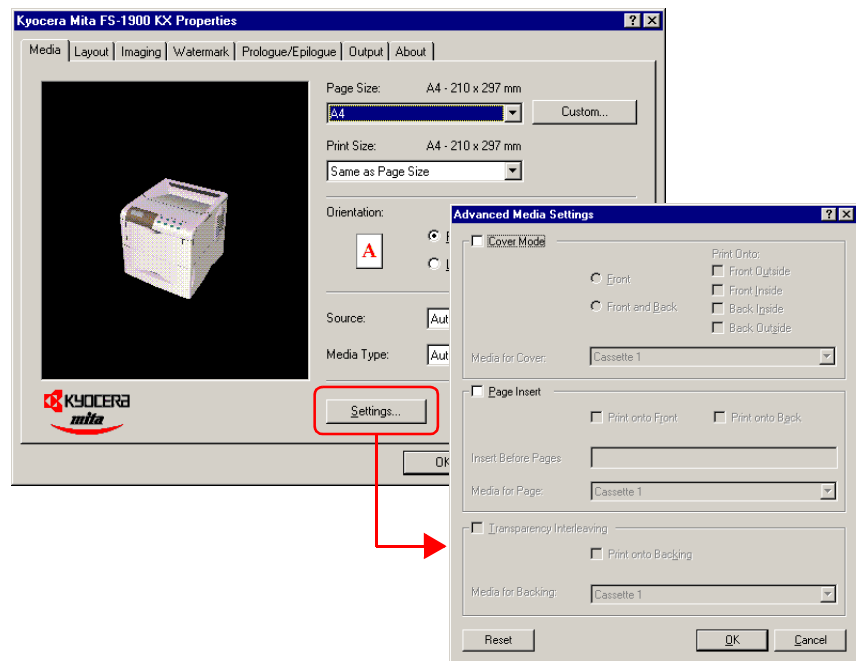

**3** Click the **Page Insert** check box.

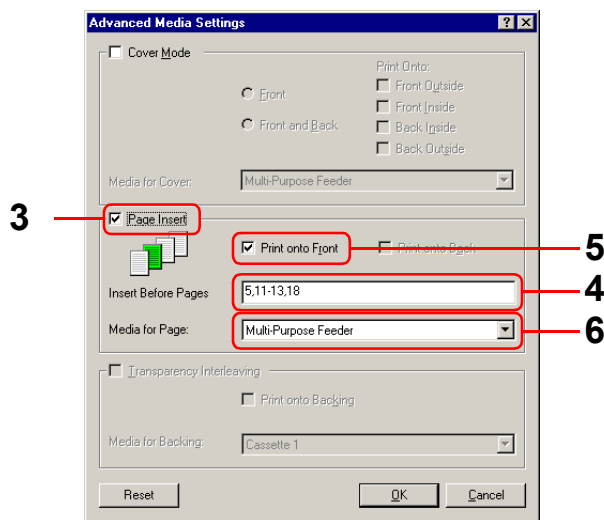

**4** Enter the page numbers before which you want to insert a page in the **Insert Before Page** box. The page number range you can specify is from 2 to 255. If you want to specify more than one page numbers, separate them with commas. To specify a range of pages, use a hyphen between the starting and ending numbers in the range. For example, to insert separators before pages 5, 11, 12, 13, and 18, type “5, 11-13, 18.”

**5** Select the **Print on to Front** check box to print on the separators. Note that the **Print onto Back** is not applicable for model FS-1900.

If you check this check box on, each separator sheet is printed with data reflecting its position in the entire print job. For example, the separator between pages 9 and 10 will be printed as page 10 when you select this check box.

**6** Select the paper source for the separators from the **Media for Page** drop down list. Note that thick paper, colored paper, etc., should be loaded on the MP tray.

**7** Click the **OK** button. The **Media** tab is displayed again.

**8** Click the **OK** button to return to the **Print** dialog box.

**9** Load the paper you want to use for the separator(s) onto the paper source specified in *step 6*.

**10** Click the **OK** button to start printing.

## Transparency Interleaving

This function is available when the current media type is Transparency and the source is MP Tray (see *Setting the Paper Type in MP Tray* on page 1-31 in the *Operation Guide*). It inserts a blank (or printed) backing sheet between the transparencies to be printed. You can print the same content of the transparency on the backing sheet.



Note

**Transparency Interleaving cannot be used with either Cover Mode or Page Insert.**

To insert sheets between transparencies.

- 1 Display the printer driver's **Properties** dialog box from the application software.
- 2 Select **Multi-Purpose Feeder** (MP Tray) from the **Source** list box and **Transparency** from the **Media Type** list.

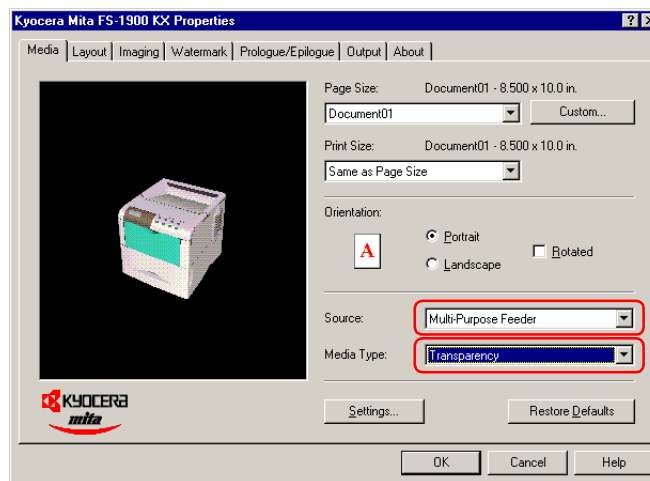

- 3 Click the **Settings** button on the **Media** tab. The **Advanced Media Settings** dialog box opens.

- 4 Click the **Transparency Interleaving** check box.

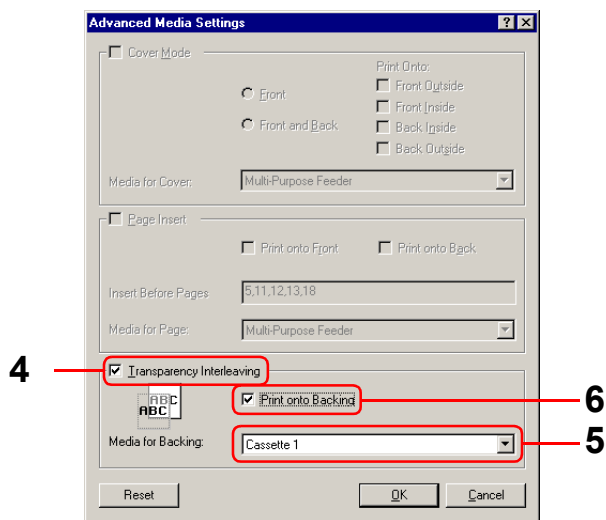

- 5 Select the source for the backing sheet from the **Media for Backing** list box, for example **Cassette 1**.
- 6 Select **Print onto Backing** if you want the same data to be printed on the backing sheet as on the transparency.
- 7 Click the **OK** button. The **Media** tab is displayed again.
- 8 Click the **OK** button to return to the **Print** dialog box.
- 9 Load the paper you want to use for the backing(s) onto the paper source specified in *step 5*.
- 10 Click the **OK** button to start printing.



## Printing Multiple Pages per Sheet

You can print multiple pages on a single sheet of paper, in groups of 1, 2, 4, 6, 9, 12, 16, or 25 pages. You can also select the layout of the pages printed on a sheet.

- 1 Display the printer driver's **Properties** dialog box from the application software.
- 2 Click the **Layout** tab.
- 3 Select the number of pages to be printed from the **Pages per Sheet** drop down list. You may select 1, 2, 4, 6, 9, 12, 16, or 25 pages. The graphic on the left will change to reflect your selection. If you want to add borders to each page printed on the sheet, click **Print Borders**.

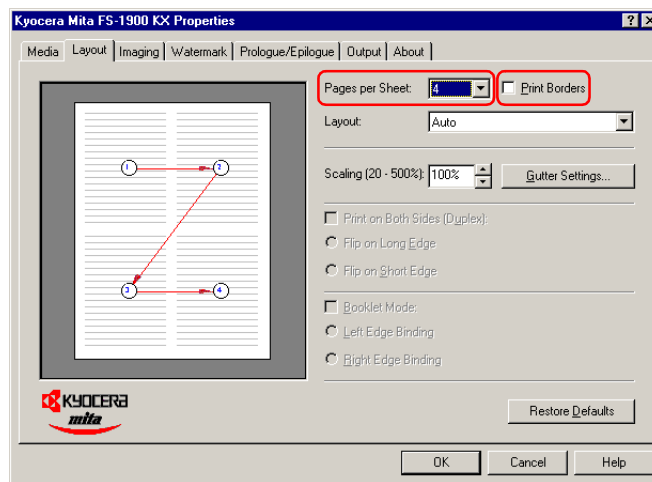

- 4 To select the relative position of each page printed on the sheet, select an option from the **Layout** drop down list.

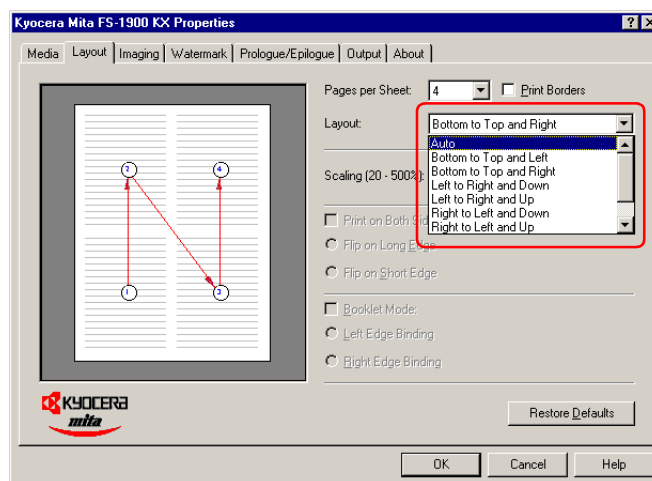

- 5 Click the **OK** button to return to the **Print** dialog box.
- 6 Click the **OK** button to start printing.

## Changing the Size of the Document

When you choose the **Scaling** option, both the height and width of the page will be scaled according to the percentage selected. The range for the scaling percentage is 20 % to 500 %.

- 1 Display the printer driver's **Properties** dialog box from the application software.
- 2 Click the **Layout** tab.
- 3 Select the desired percentage from the **Scaling** box.

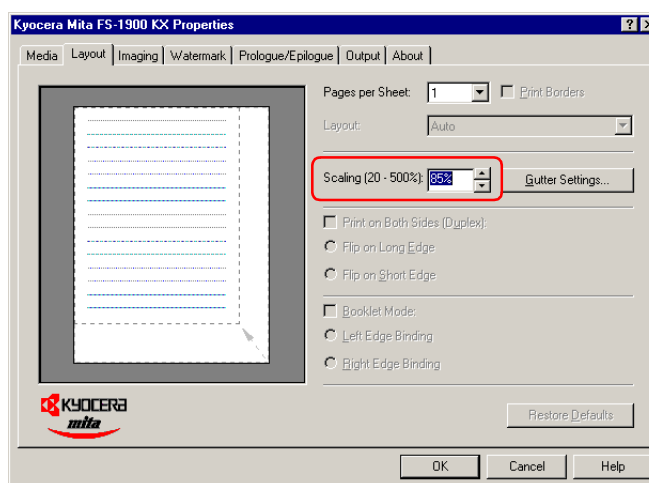



- 4 Click the **OK** button to return to the **Print** dialog box.
- 5 Click the **OK** button to start printing.

## Changing the Resolution

You can set the resolution of the print job. Available options are: **High Quality** (Fast 1200 mode), **Proof** (600 dpi), **Draft** (300 dpi), and **Custom**.

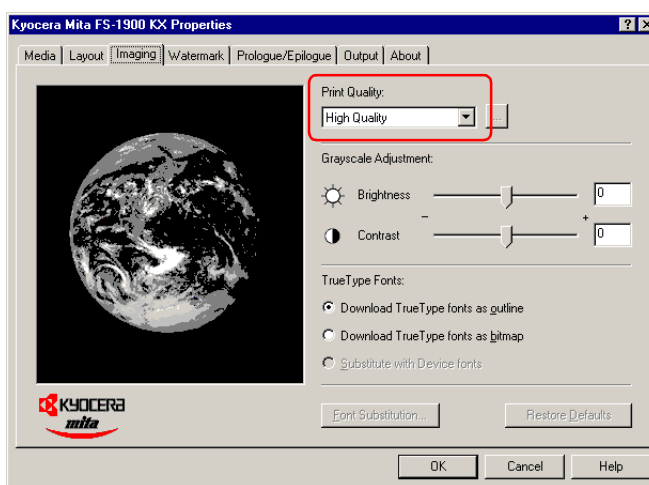
- 1 Display the printer driver's **Properties** dialog box from the application software.
- 2 Click the **Imaging** tab.
- 3 Select the resolution of the print job from the **Print Quality** drop down list.



- 4 If you want to set **Resolution**, **Kyocera Image Refinement**, and **EcoPrint** individually, choose **Custom** and click the  button next to the **Print Quality** drop down list. Select the options you need in the **Print Quality Settings** dialog box.

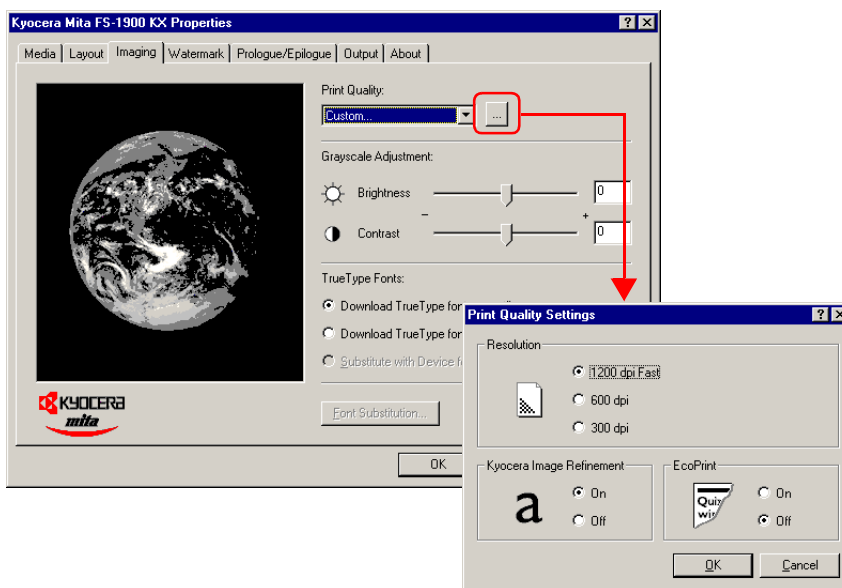

- 5 Click the **OK** button. The **Image** tab is displayed again.
- 6 Click the **OK** button to return to the **Print** dialog box.
- 7 Click the **OK** button to start printing.

## Adjusting Grayscale

You can adjust the appearance of the graphic images of your printed job by using the options under **Grayscale Adjustment**. The **Grayscale Adjustment** options are useful if the printed graphic images are too light, too gray, or too dark.



Note

**Text is unaffected by the Grayscale Adjustment settings.**

- 1 Display the printer driver's **Properties** dialog box from the application software.
- 2 Click the **Imaging** tab.
- 3 To lighten or darken the graphic images, drag the **Brightness** slider.

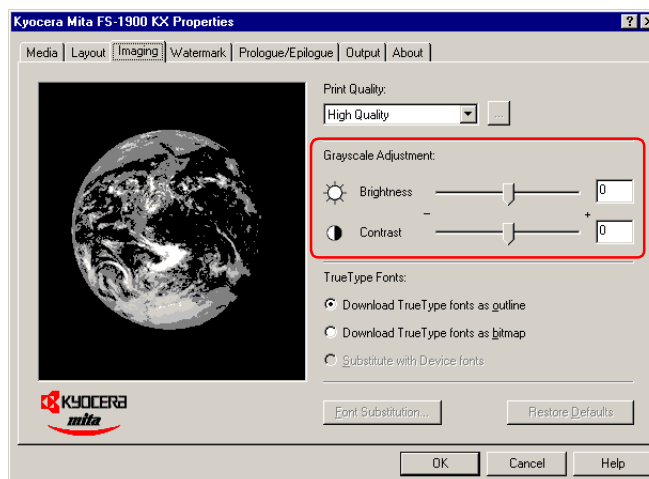

- 4 To control the levels of gray, use the **Contrast** slider.
- 5 Click the **OK** button to return to the **Print** dialog box.
- 6 Click the **OK** button to start printing.

## TrueType Fonts

You can specify how TrueType fonts will be sent to the printer. Also you can substitute a certain font in your document with a specified font. The selected method will affect the speed at which your print job is produced and may resolve some font printing issues.

- 1 Display the printer driver's **Properties** dialog box from the application software.
- 2 Click the **Imaging** tab.
- 3 To specify how TrueType fonts are sent to the printer, select one of the options from **TrueType Fonts**:

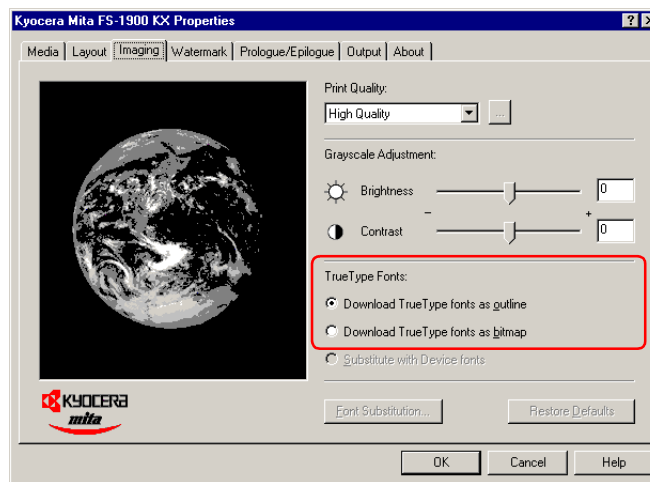

- Select **Download TrueType fonts as outline** to reduce the file size for printing a large document, especially if it contains several fonts or several font sizes. This is the default setting.
- Select **Download TrueType fonts as bitmap** for a print job with fewer fonts and similar font sizes, though file size will be larger.

- 4 Click the **OK** button to return to the **Print** dialog box.
- 5 Click the **OK** button to start printing.

## Watermark Printing

A watermark can be printed in a document. In addition to the existing watermarks **Confidential 1**, **Confidential 2**, **Copy**, and **Sample**, a new watermark can be created. Also the print position, font, size, etc. can be specified freely.

- 1 Display the printer driver's **Properties** dialog box from the application software.
- 2 Click the **Watermark** tab.
- 3 Remove the check mark of **Disable Feature**.

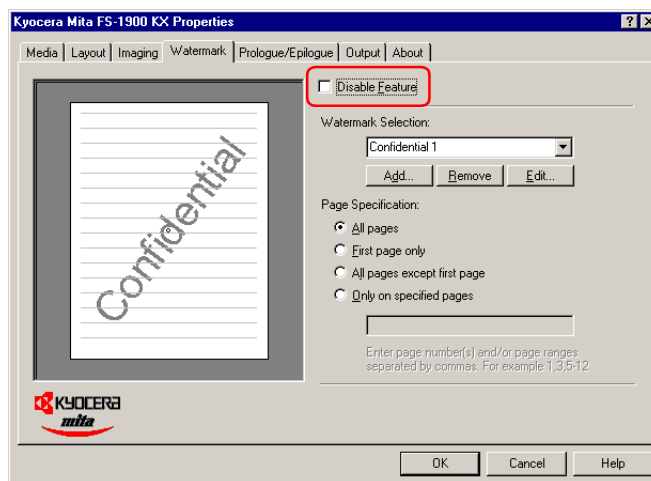

- 4 Select the desired watermark type from the **Watermark Selection** drop down list.

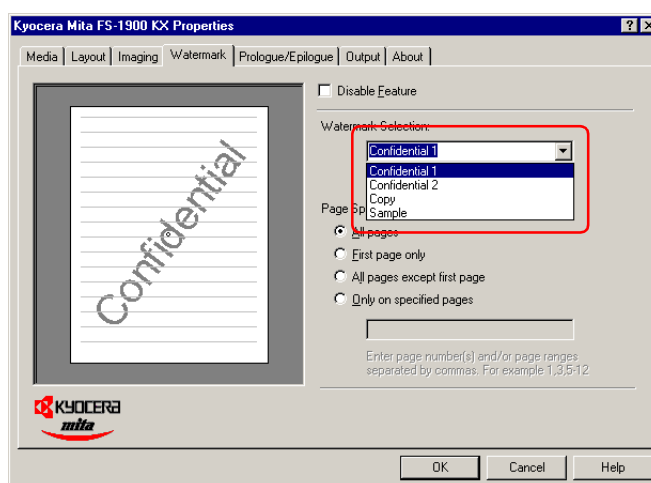

When creating or changing the watermark, click the **Add** or **Edit** button. The **Watermark Properties** dialog box opens. Specify the print position, font, size, etc. The graphic on the left will change to reflect your selection. Click the **OK** button. The new watermark will be added to the **Watermark Selection** drop down list.

- 5** Select **All pages**, **First page only**, **All pages except first page**, or **Only on specified pages** for **Page Specification**.

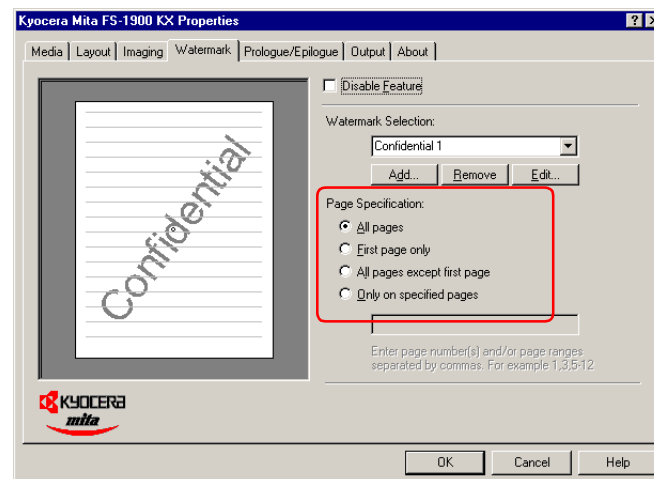

If you have selected **Only on specified pages**, enter the numbers of the pages on which the watermark is to be printed. If you want to specify more than one page numbers, separate them with commas. To specify a range of pages, use a hyphen between the starting and ending numbers in the range. For example, to print the watermark on pages 5, 11, 12, 13, and 18, type “5, 11-13, 18.”

- 6** Click the **OK** button to return to the **Print** dialog box.
- 7** Click the **OK** button to start printing.

## Using the Duplexer (DU-60)

You can print on both sides of paper by using the paper cassette, or option paper feeder if installed.

You can use long-edge or short-edge binding combined with either landscape or portrait printing. Use **Orientation** options on the **Media** tab to select the page orientation as follows.

These are: (1) portrait, long-edge, (2) portrait, short-edge, (3) landscape, long-edge, and (4) landscape, short-edge. The figure below shows these binding setups.

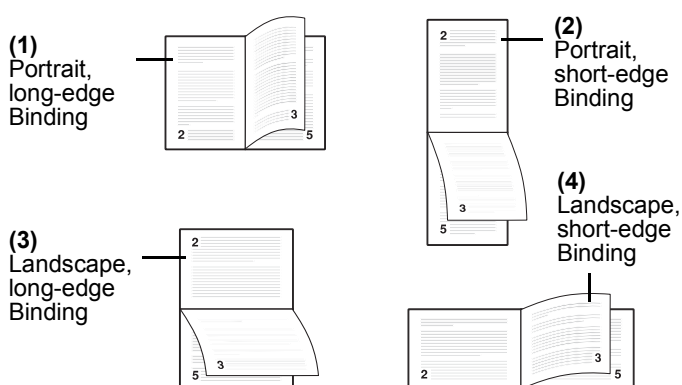

Also if you use the booklet mode, two pages will be printed on one side. You can make a book type document by folding the output document together. For the booklet mode, you can specify left edge binding or right edge binding.

Left edge binding

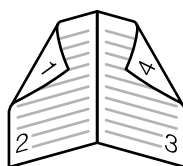

Right edge binding

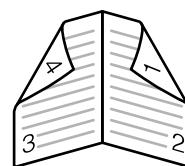



- 1 Display the printer driver's **Properties** dialog box from the application software.
- 2 Click the **Layout** tab.
- 3 When printing on both sides, click **Print on Both Sides (Duplex)** and then check the **Flip on Long Edge** or **Flip on Short Edge** radio button. The graphic icon will change to illustrate your selection.

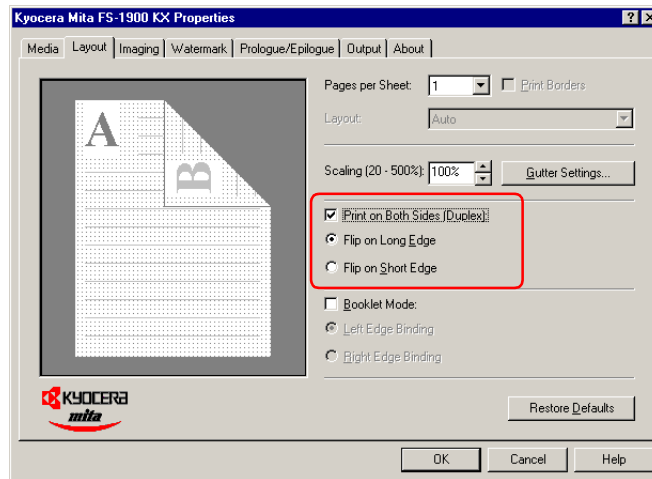

When using the booklet mode, click **Booklet Mode** and then check the **Left Edge Binding** or **Right Edge Binding** radio button. The graphic icon will change to illustrate your selection.

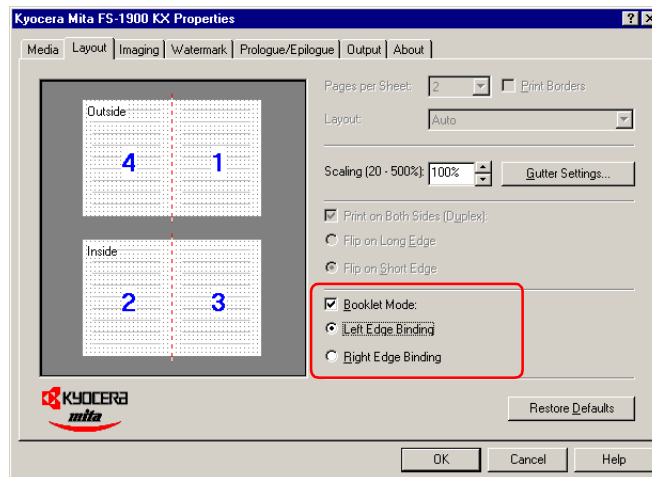

- 4 To set the width of the gutter, click the **Gutter Settings** button and enter the desired value in the **Gutter** field. The width of the gutter ranges from 5.00 to 25.4 mm or from 0.20 to 1.00 inch.

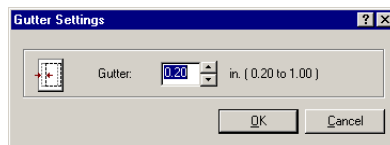

- 5 Click the **OK** button.  
To change the default setting to duplex printing, make this setting from Windows.
- 6 The **Print** dialog box is displayed again. Click the **OK** button to start printing.

## Using the Sorter (SO-60)

When outputting to the sorter, you can select one of the collate mode, group mode, and mailbox mode. For the function of each mode, see [Sorter modes](#) on page [3-23](#).

- 1 Display the printer driver's **Properties** dialog box from the application software.
- 2 Click the **Output** tab.
- 3 Select **Mailbox [Face-down]** as **Output to** drop down list. To understand sorter modes, see page [3-23](#).

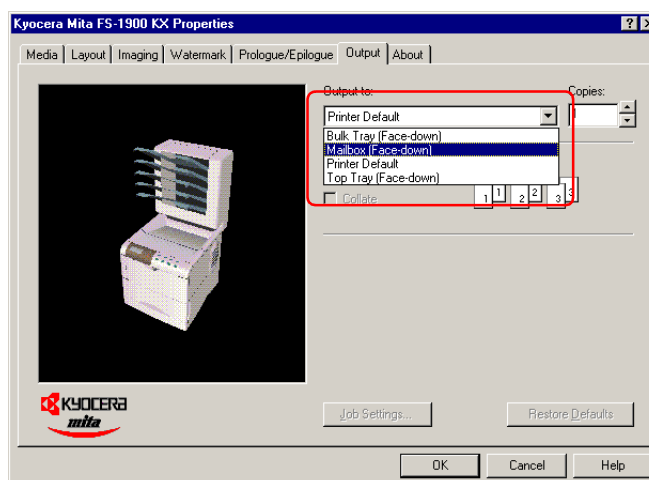

**4** To use the collate mode, check mark the **Collate** check box.

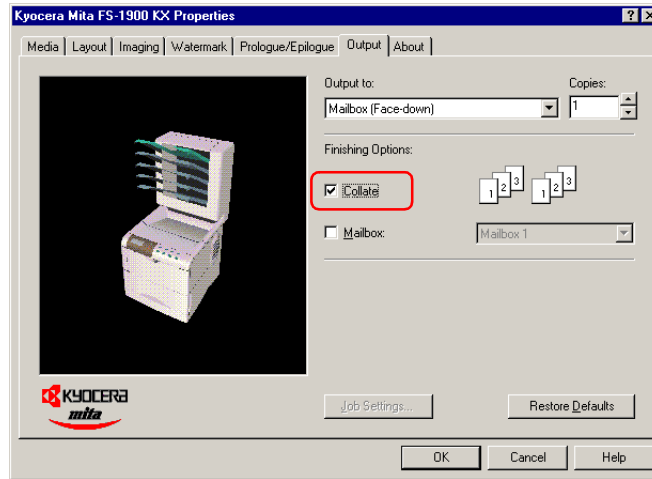

To use the group mode, remove the check mark of **Collate**.

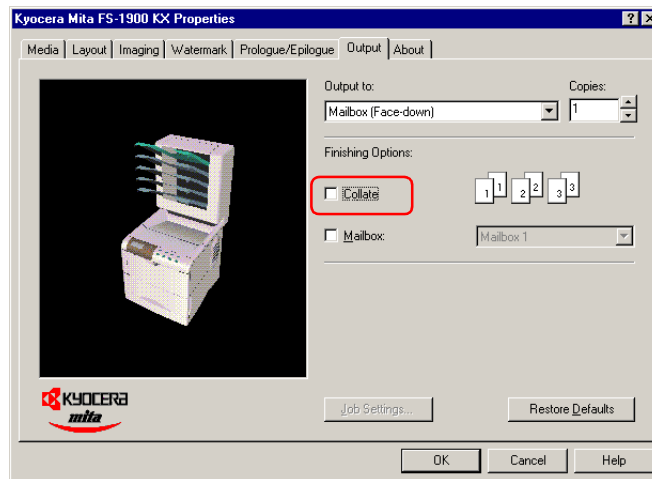

To use the mailbox mode, check mark the **Mailbox** check box and select a mailbox in the **Mailbox** drop down list.

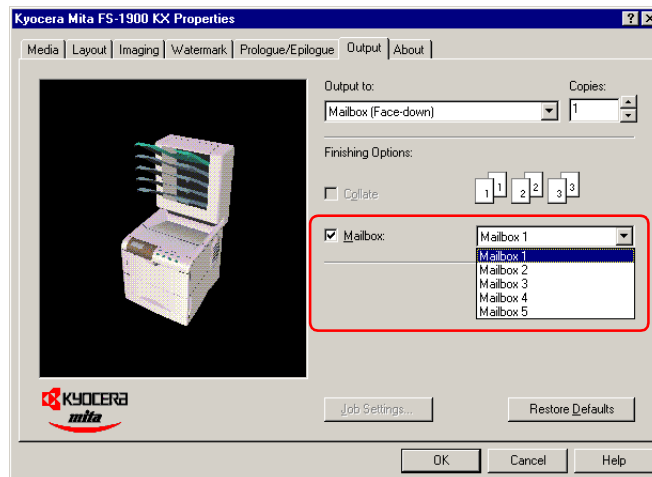

Sorter modes

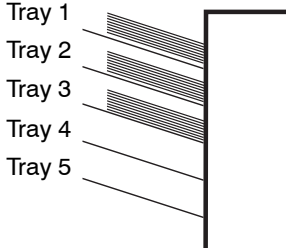
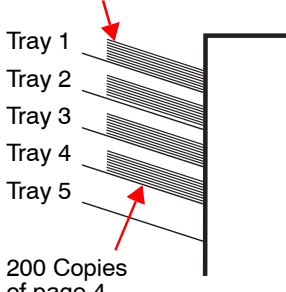
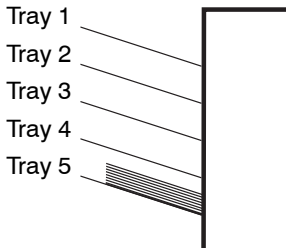
Sorter Mode	Description
<p>Collate mode</p>  <p>Tray 1 Tray 2 Tray 3 Tray 4 Tray 5</p>	<p>The collate mode delivers the output pages by copy as shown in the example. This mode is useful when you need several independent copies of a document.</p> <p>The maximum number of copies is 5. If a tray becomes full (approximately 200 pages), the printer pauses and indicates the Option tray # paper full message. Then, you will need to remove all the printed pages from the tray indicated by # in the message.</p> <p>In the example, three copies of a document of 200 pages long are made, and each copy is stacked in trays 1, 2, and 3, respectively.</p>
<p>Group mode</p>  <p>200 Copies of page 1 Tray 1 Tray 2 Tray 3 Tray 4 Tray 5 200 Copies of page 4</p>	<p>The group mode delivers the output pages by page as shown in the example. When multiple copies of a file are printed, all copies of a single page are delivered together to a single tray.</p> <p>The maximum number of copies is 200. If a tray becomes full (200 pages), the printer pauses and indicates the Option tray # paper full message. Then, you will need to remove all the printed pages from the tray indicated by # in the message.</p> <p>In the example, we make 200-copy stacks of each page of an 4-page long document.</p>
<p>Mailbox mode 1 to 5</p>  <p>Tray 1 Tray 2 Tray 3 Tray 4 Tray 5</p>	<p>The mailbox mode delivers the printed pages to the tray you specify on the printer driver.</p> <p>When the sorter tray becomes full, the printer indicates the Option tray # paper full message and pauses until you remove all the pages in the sorter tray indicated by # in the message.</p> <p>In the example, sorter tray 5 is specified to receive the printed pages.</p>

- 5 Click the **OK** button in the **Properties** dialog box. The **Print** dialog box is displayed again. Click the **OK** button to start printing.

## e-MPS

### Job Retention

This function allows you to save print jobs to the option Microdrive and print them out as desired at the operator panel.

When printing, select a Job Retention mode at the printer driver. The following four modes are available:

- Quick Copy Printing ..... See page [3-26](#)
- Proof and Hold Printing ..... See page [3-28](#)
- Private Printing ..... See page [3-30](#)
- Stored Job Printing (Job Storage) ..... See page [3-32](#)

For how to make the settings, see the pages of the respective modes.

Four Job Retention modes have the following benefits:

- **Quick Copy:** When you need another copy of a finished print job, you can print it out at the printer operator panel. There is no need to print from the computer again.
- **Proof and Hold:** When printing multiple copies, this mode first prints only one copy for proofing, allowing you to decide whether to continue printing the remaining copies or cancel printing at the operator panel. In this way, you can reduce the waste of paper.
- **Private Print:** Confidential print jobs can be printed out when you are at the printer. This mode saves print jobs in the printer without printing until you instruct the printer to do so at the operator panel. Printing using this mode requires the 4-digit PIN number you set using the printer driver.
- **Stored Job (Job Storage):** This mode allows you to store print jobs that are frequently needed, such as fax cover pages, checklists, and order forms, for printing later. Using the operator panel, you can then print them out as required at anytime and at any number of copies.

### **Virtual Mail Box**

Virtual mailbox is the ability to store print jobs in the virtual mailboxes on the Microdrive, enabling you to retrieve and print it later from the printer's operator panel.

You can later print out only the jobs you desire using the operator panel on the printer.

When printing, make the settings at the printer driver. For how to make the settings, see *Virtual Mailbox Printing* on page **3-34**.

You can send a print job either to all the virtual mail box trays at the same time or to the desired trays only.

Since you perform printing by selecting the desired trays using the operator panel, you can print out only the jobs you desire.

### **Code Job (Temporary and Permanent)**

Job Storage reduces the time to print multiple copies.

When printing, select a type of code job at the printer driver. The following two types of code jobs are available:

- Permanent Code Job
- Temporary Code Job

For how to make the settings, see *Printing a Code Job* on page **3-39**.

You can print out frequently needed print jobs, such as fax cover pages, checklists, and order forms.

You can print a list of code jobs at the operator panel. There are two types of code jobs: permanent code job and temporary code job. When the storage memory becomes insufficient, temporary code jobs will be automatically deleted in order from the oldest and permanent code jobs will not.

## Using Job Retention

### Quick Copy Printing

This allows you to print as many additional copies as you want until the printer is turned off, it is useful in cases such as when there are sudden increases in the required number of copies during a meeting.

To print, proceed as follows.

- 1 Display the printer driver's **Properties** dialog box from the application software.
- 2 Click the **Output** tab and then click the **Job Settings** button.

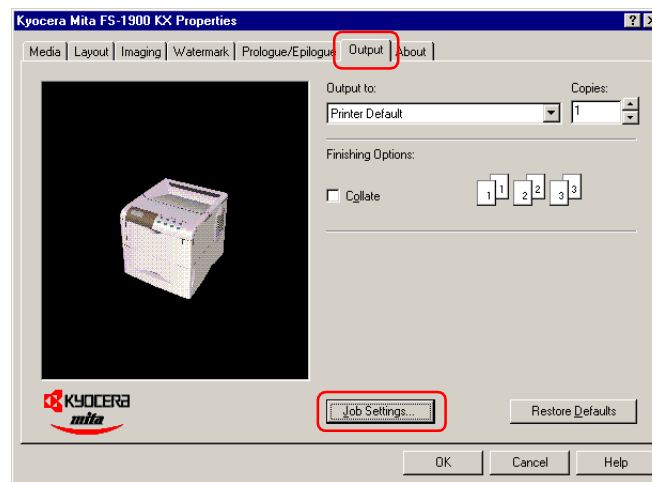

The **Job Settings** dialog box will appear.

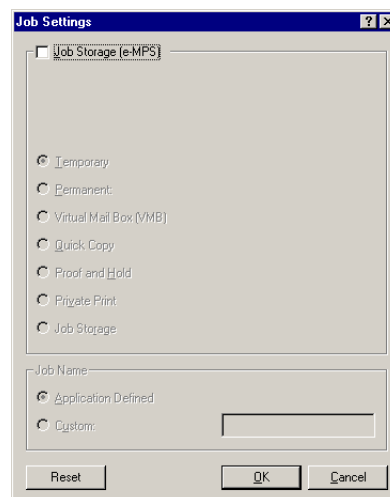

**3** Check the **Job Storage (e-MPS)** checkbox and then check the **Quick Copy**.

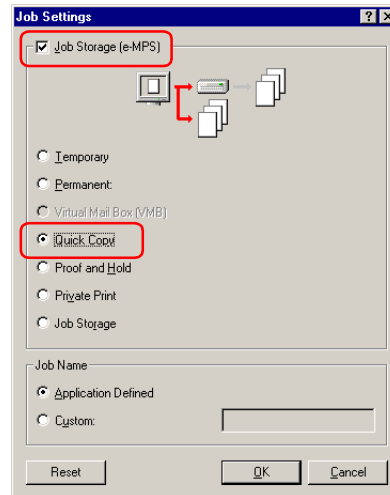

**4** Click the **OK** button. The **Print** dialog box is displayed again. Click the **OK** button to start printing. The print job will be saved to the Microdrive as it is printed.

If additional copies are required, print using the Quick Copy menu in the e-MPS menu at the printer operator panel. For details, see page 1-57 in the *Operation Guide*.



### Proof and Hold Printing

You can check the first copy before printing the remaining copies, paper wastage can be avoided. The print jobs will be deleted when the printer is turned off.

To print, proceed as follows.

- 1 Display the printer driver's **Properties** dialog box from the application software.
- 2 Click the **Output** tab and then click the **Job Settings** button.

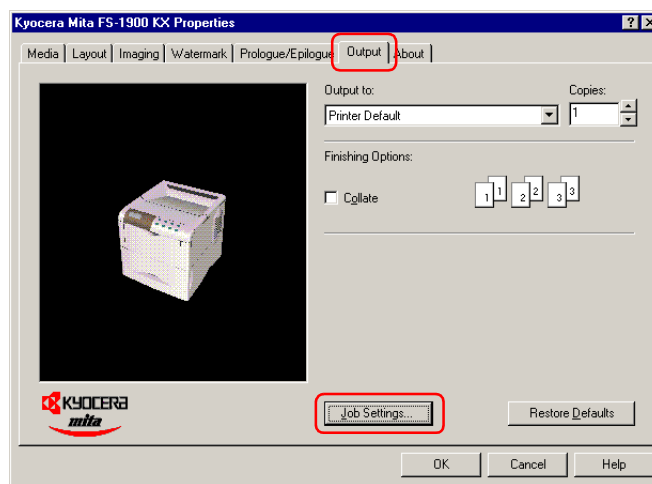

The **Job Settings** dialog box will appear.

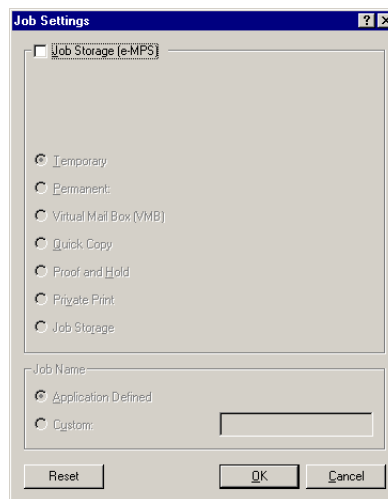

**3** Check the **Job Storage (e-MPS)** checkbox, and then check the **Proof and Hold**.

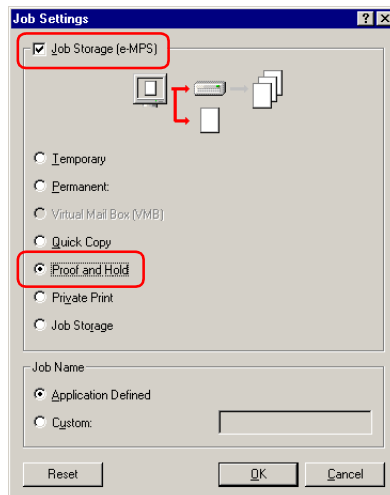

**4** Click the **OK** button. The **Print** dialog box is displayed again. Click the **OK** button to start printing. The print job will be stored to the Microdrive as it is printed.

The printer will first print only one copy if you set to print multiple number of copies, allowing you to check the printouts. If there is no problem, resume printing the remaining copies using the **Quick Copy** menu in the **e-MPS** menu at the printer operator panel. For details, see page **1-59** in the **Operation Guide**.

## Private Printing

You need to enter a password at retrieving the job, confidentiality is assured even if you share the printer with others. Print jobs will be deleted when they are printed or when the printer is turned off.

To print, proceed as follows.

- 1 Display the printer driver's **Properties** dialog box from the application software.
- 2 Click the **Output** tab and then click the **Job Settings** button.

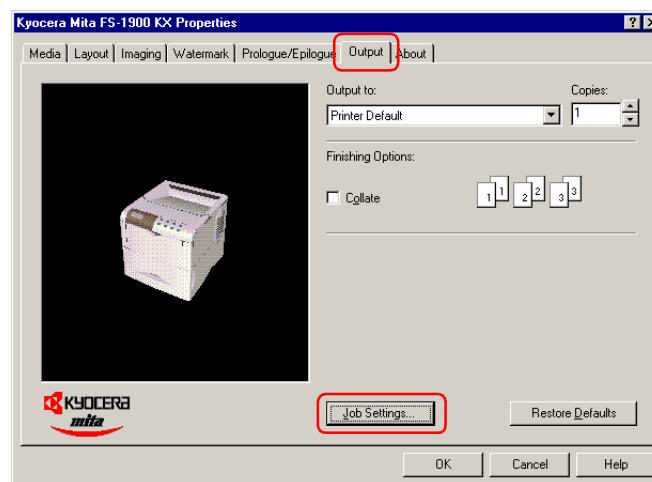

The **Job Settings** dialog box will appear.

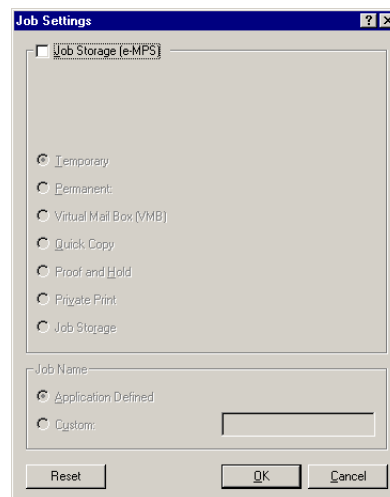

- 3** Check the **Job Storage (e-MPS)** checkbox, and then check the **Private Print**.

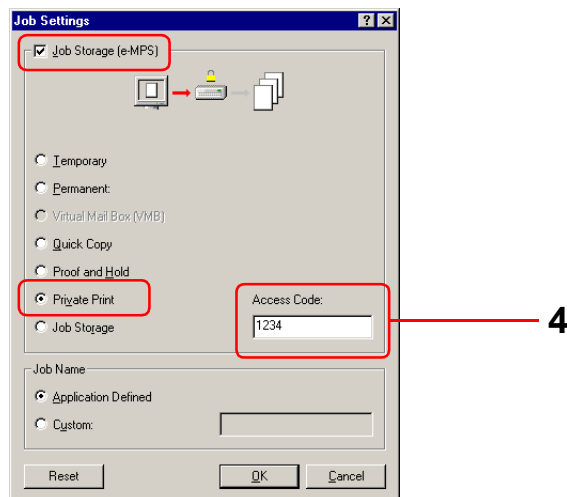

- 4** Set the desired 4-digit access code using any numbers between 0 and 9. This number is synonymous to user ID which is required to enter at the printer operator panel when retrieving.

- 5** Click the **OK** button. The **Print** dialog box is displayed again. Click the **OK** button. The print job will be stored to the Microdrive without printing.

To print, use the **Private/Stored** menu in the **e-MPS** menu at the printer operator panel. For details, see page **1-61** in the **Operation Guide**.

### Stored Job Printing (Job Storage)

Select this if you want to store frequently needed print jobs, such as forms, to print them later as required. The print jobs will not be deleted when the printer is turned off.

To print, proceed as follows.

- 1 Display the printer driver's **Properties** dialog box from the application software.
- 2 Click the **Output** tab and then click the **Job Settings** button.

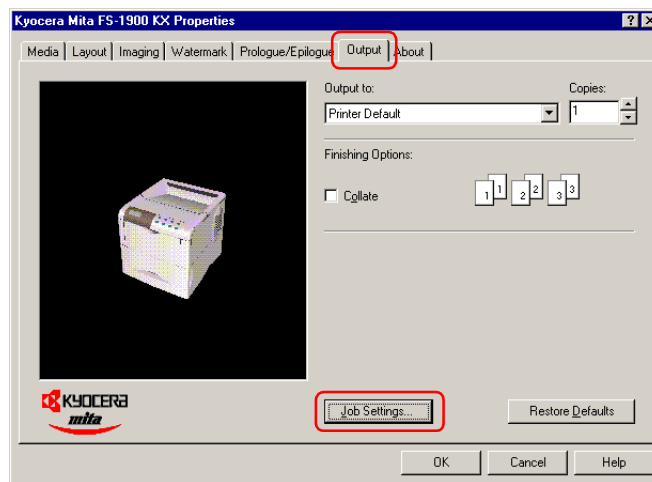

The **Job Settings** dialog box will appear.

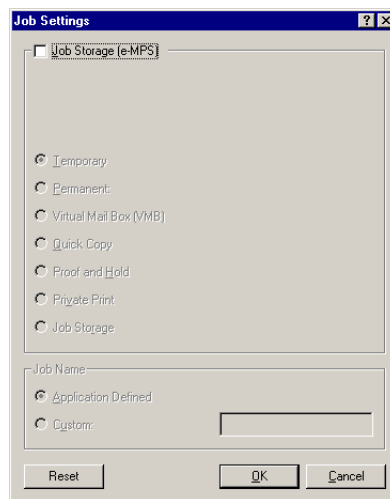

- 3** Check the **Job Storage (e-MPS)** checkbox, and then check the **Job Storage**.

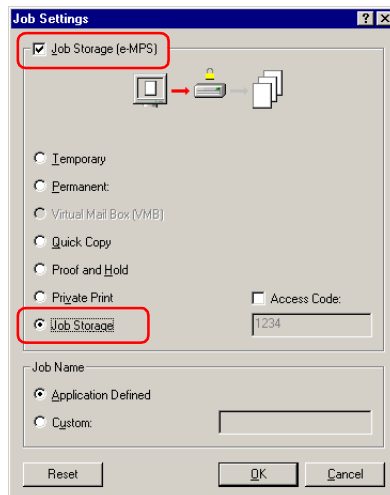

- 4** You can add security to the print job. To do so, check the **Access Code** checkbox and enter the desired 4-digit access code using any numbers between 0 and 9. You must enter this number at the printer operator panel when printing.

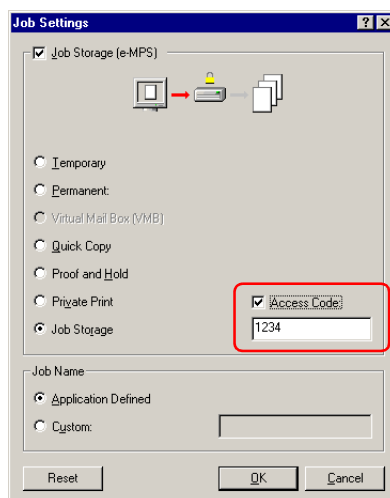

- 5** Click the **OK** button. The **Print** dialog box is displayed again. Click the **OK** button. The print job will be stored to the Microdrive without printing.

To print, use the **Private/Stored** menu in the **e-MPS** menu at the printer operator panel. For details, see page **1-63** in the **Operation Guide**.

## Virtual Mailbox Printing



Virtual Mailbox function is available only when PCL 5e or PCL XL is selected as emulation.

Virtual mailbox is the ability to store print jobs in the virtual mailboxes on the Microdrive, enabling you to retrieve and print it later from the printer's operator panel. A maximum of 255 virtual mailboxes can be set up, making it possible to allocate documents not just for individual departments or groups, but even for individual people. The print jobs will not be deleted when the printer is turned off.

### Before Using Virtual Mailboxes

To use the virtual mailbox function, select **PCL XL** or **PCL 5e** emulation and then set the **Mailbox Name** and **Virtual Output Tray** beforehand. Follow these procedures.

- 1 Browse through Windows **Start > Settings > Printers**.
- 2 Right click on the **Kyocera Mita FS-1900 KX** icon and then click **Properties**.

The **Properties** dialog box is displayed.

- 3 Click the **Device Settings** tab.

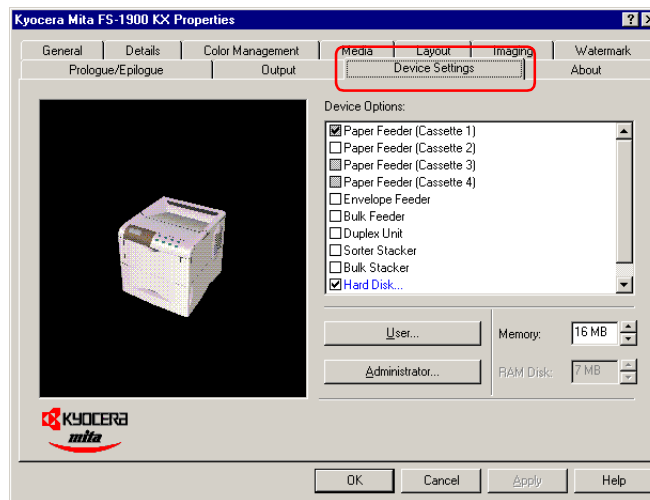

**4** Click the **User** button. The **User Settings** dialog box is displayed.

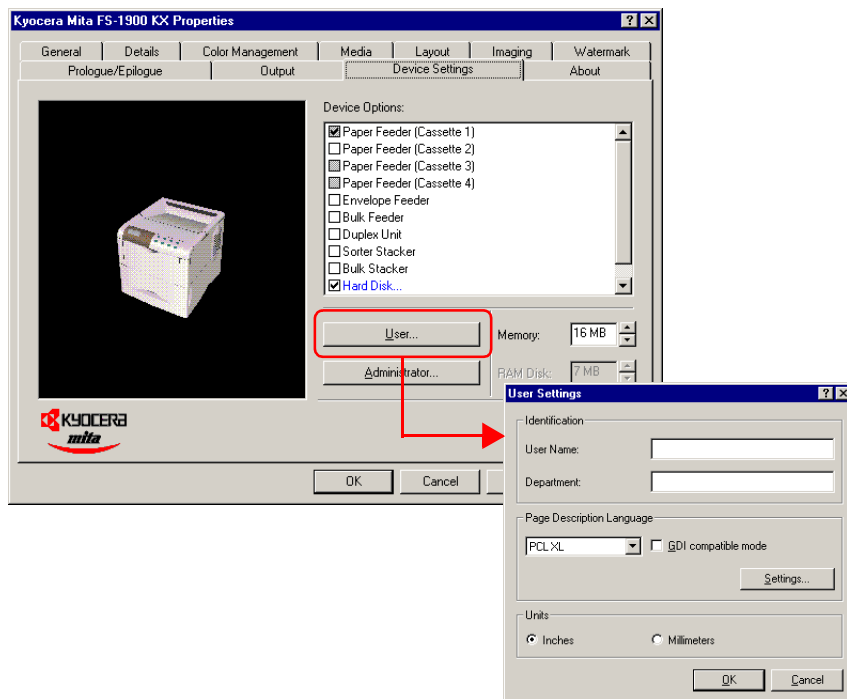

**5** Select **PCL XL** or **PCL 5e** in the **Page Description Language** drop down list, and click the **OK** button.

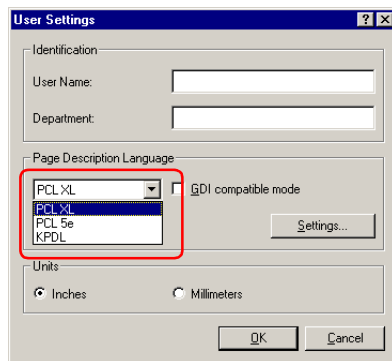



**6** Double-click **Hard Disk** in the **Device Options** list. The **Hard Disk Settings** dialog box will be displayed.

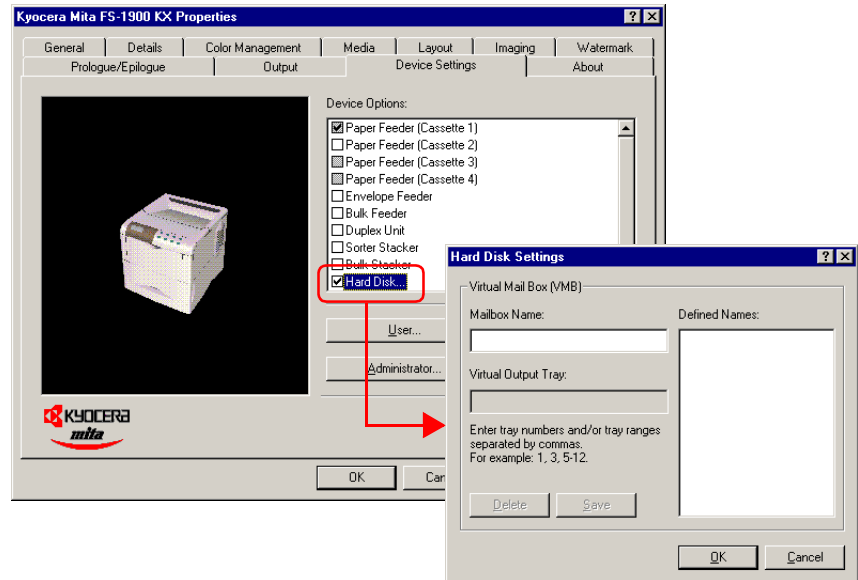

**7** Enter the mailbox name in the **Mailbox Name**, and the tray number in the **Virtual Output Tray**, and then click the **Save** button.

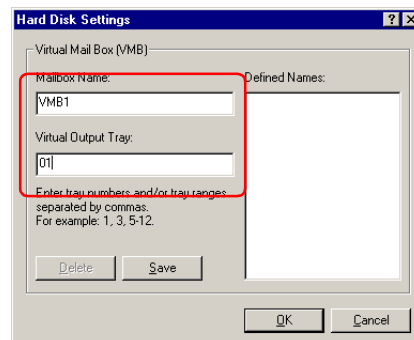

**Note**

Multiple virtual mailbox tray number can be specified at a time using commas (,) and hyphen (-).

The mailbox name will be displayed in the **Defined Names** list box.

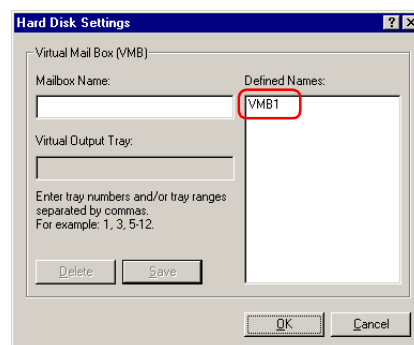

- 8 Click the **OK** button to quit the **Hard Disk Settings** dialog box.
- 9 Click the **OK** button.

### Using VMB Printing

To print, proceed as follows.

- 1 Display the printer driver's **Properties** dialog box from the application software.
- 2 Click the **Output** tab and then click the **Job Settings** button.

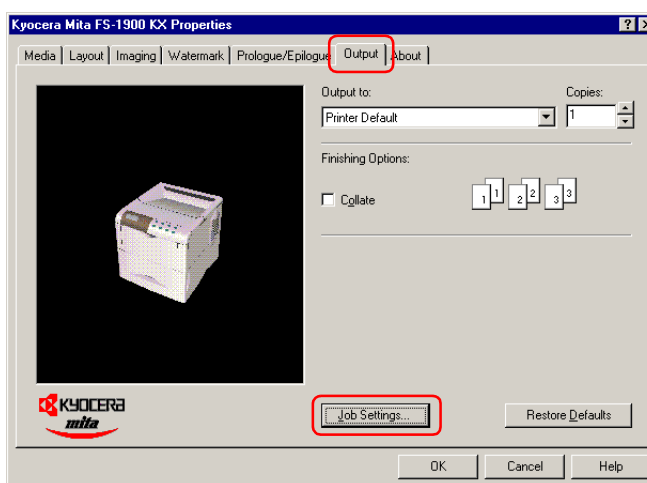

The **Job Settings** dialog box will appear.

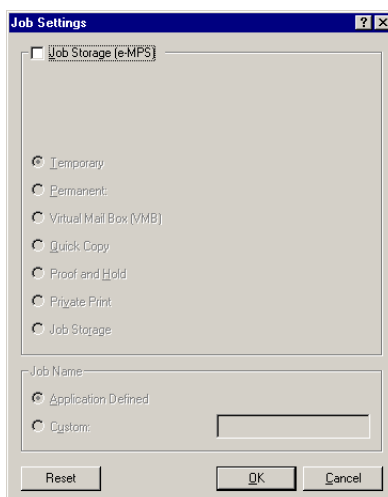

**3** Check the **Job Storage (e-MPS)** checkbox, and then check the **Virtual Mail Box [VMB]**.

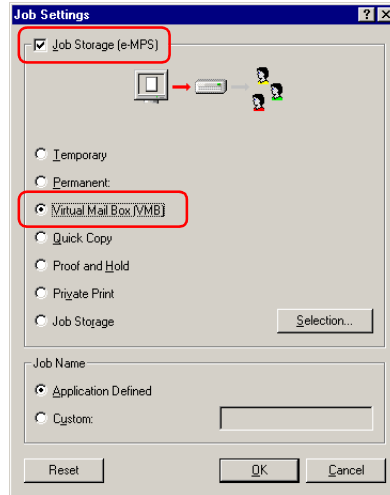

**4** Click the **Selection** button. The **Virtual Mailbox Selection** dialog box will appear. Select one or more mail-boxes from the list of **Defined Names**.

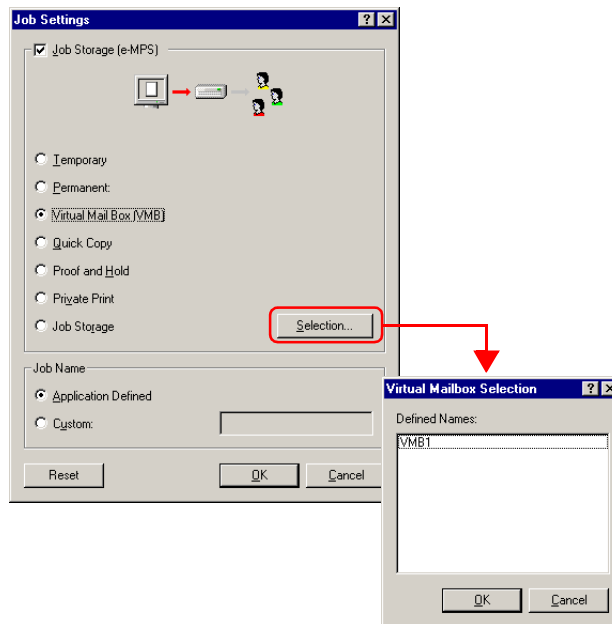

**5** Click the **OK** button. The **Print** dialog box is displayed again. Click the **OK** button. The print job will be stored to the Microdrive without printing.

To print, use the **Print VMB Data** menu in the **e-MPS** menu at the printer operator panel and specify the virtual mail box numbers. You can also print the list of virtual mail box trays. For details, see page **1-68** in the *Operation Guide*.

## Printing a Code Job

A unique number is automatically assigned to each job as it is stored on the printer. The number appears when jobs are listed in utilities included in the CD-ROM such as **Printer Disk Manager** or **KM-NET VIEWER**. The number is also printed on the Job List that can be printed using the **List of Code Job** menu of the printer.

To print, proceed as follows.

- 1 Display the printer driver's **Properties** dialog box from the application software.
- 2 Click the **Output** tab and then click the **Job Settings** button.

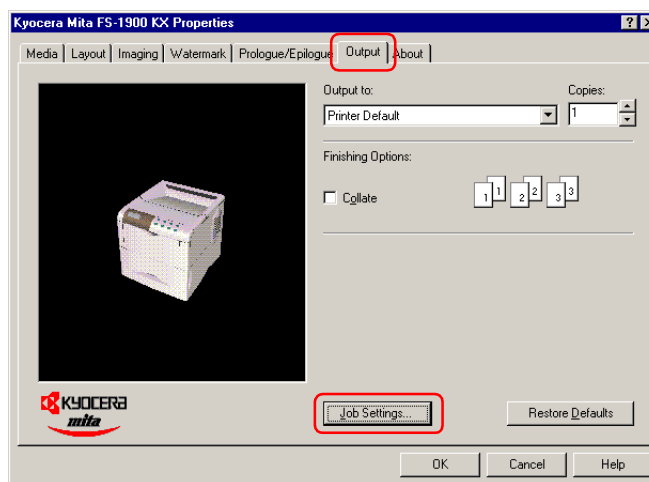

The **Job Settings** dialog box will appear.

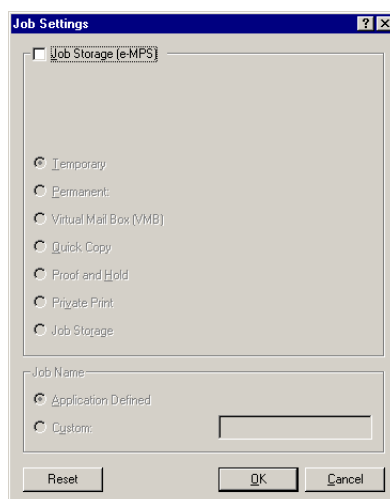

- 3 Check the **Job Storage (e-MPS)** checkbox and then the **Temporary** or **Permanent** radio button.

- 4 Click the **OK** button. The **Print** dialog box is displayed again. Click the **OK** button to start printing. The print job will be stored to the Microdrive as it is printed.



## Free Manuals Download Website

<http://myh66.com>

<http://usermanuals.us>

<http://www.somanuals.com>

<http://www.4manuals.cc>

<http://www.manual-lib.com>

<http://www.404manual.com>

<http://www.luxmanual.com>

<http://aubethermostatmanual.com>

Golf course search by state

<http://golfingnear.com>

Email search by domain

<http://emailbydomain.com>

Auto manuals search

<http://auto.somanuals.com>

TV manuals search

<http://tv.somanuals.com>