

---

**FS-6950DN**

# **Operation Guide**





# Contents

|          |   |      |
|----------|---|------|
| <b>1</b> | <b>Machine Parts</b>  |      |
|          | Components at the Front of the Printer . . . . .                        | 1-2  |
|          | Components at the Left of the Printer and Internal Components . . . . . | 1-2  |
|          | Components at the Rear of the Printer . . . . .                         | 1-3  |
| <b>2</b> | <b>Printing Operation</b>   |      |
|          | Loading Printer Driver . . . . .  | 2-2  |
|          | Printing from Application Software . . . . .                            | 2-3  |
| <b>3</b> | <b>Maintenance</b>  |      |
|          | General Information . . . . .   | 3-2  |
|          | Toner Container Replacement . . . . .                                   | 3-3  |
|          | Cleaning the Printer . . . . .  | 3-8  |
| <b>4</b> | <b>Troubleshooting</b>  |      |
|          | General Guidelines . . . . .  | 4-2  |
|          | Print Quality Problems . . . . .  | 4-3  |
|          | Error Messages . . . . .  | 4-5  |
|          | Clearing Paper Jams . . . . .   | 4-11 |
| <b>5</b> | <b>Specifications</b>   |      |



# Legal and Safety Information

---

**CAUTION: NO LIABILITY IS ASSUMED FOR ANY DAMAGE CAUSED BY IMPROPER INSTALLATION.**

---

## Notice on Software

SOFTWARE USED WITH THIS PRINTER MUST SUPPORT THE PRINTER'S EMULATION MODE. The printer is factory-set to emulate the PCL. The emulation mode can be changed.

## Notice

The information in this guide is subject to change without notification. Additional pages may be inserted in future editions. The user is asked to excuse any technical inaccuracies or typographical errors in the present edition.

No responsibility is assumed if accidents occur while the user is following the instructions in this guide. No responsibility is assumed for defects in the printer's firmware (contents of its read-only memory).

This guide, any copyrightable subject matter sold or provided with or in connection with the sale of the page printer, are protected by copyright. All rights are reserved. Copying or other reproduction of all or part of this guide, any copyrightable subject matter without the prior written consent of Kyocera Mita Corporation is prohibited. Any copies made of all or part of this guide, any copyrightable subject must contain the same copyright notice as the material from which the copying is done.

## Regarding Tradenames

PRESCRIBE is a registered trademark of Kyocera Corporation. KPDL is trademark of Kyocera Corporation.

Hewlett-Packard, PCL, and PJI are registered trademarks of Hewlett-Packard Company. Centronics is a trade name of Centronics Data Computer Inc. PostScript is a registered trademark of Adobe Systems Incorporated. Macintosh is a registered trademark of Apple Computer, Inc. Microsoft, Windows, and Windows NT are registered trademarks of Microsoft Corporation. Microsoft Windows Server is a trademark of Microsoft Corporation. PowerPC is a trademark of International Business Machines Corporation. Microdrive is a registered trademark of Hitachi Global Storage Technologies Netherlands B.V. in the US and other countries. CompactFlash is a trademark of SanDisk Corporation. ENERGY STAR is a U.S. registered mark. All other brand and product names are registered trademarks or trademarks of their respective companies.

---

This product uses PeerlessPrintXL to provide the HP LaserJet compatible PCL 6 language emulation. PeerlessPrintXL is a trademark of Peerless Systems Corporation, 2381 Rosecrans Ave. El Segundo, CA 90245, U.S.A.

This product was developed using the Tornado™ Real Time Operating System and Tools from Wind River Systems.

This product contains UFST™ and MicroType® from Monotype Imaging Inc.

## USB



This product has been certified by the USB Implementers Forum, Inc.

---

## License Agreements

### IBM Program License Agreement

THE DEVICE YOU HAVE PURCHASED CONTAINS ONE OR MORE SOFTWARE PROGRAMS ("PROGRAMS") WHICH BELONG TO INTERNATIONAL BUSINESS MACHINES CORPORATION ("IBM"). THIS DOCUMENT DEFINES THE TERMS AND CONDITIONS UNDER WHICH THE SOFTWARE IS BEING LICENSED TO YOU BY IBM. IF YOU DO NOT AGREE WITH THE TERMS AND CONDITIONS OF THIS LICENSE, THEN WITHIN 14 DAYS AFTER YOUR ACQUISITION OF THE DEVICE YOU MAY RETURN THE DEVICE FOR A FULL REFUND. IF YOU DO NOT SO RETURN THE DEVICE WITHIN THE 14 DAYS, THEN YOU WILL BE ASSUMED TO HAVE AGREED TO THESE TERMS AND CONDITIONS.

The Programs are licensed not sold. IBM, or the applicable IBM country organization, grants you a license for the Programs only in the country where you acquired the Programs. You obtain no rights other than those granted you under this license.

The term "Programs" means the original and all whole or partial copies of it, including modified copies or portions merged into other programs. IBM retains title to the Programs. IBM owns, or has licensed from the owner, copyrights in the Programs.

#### 1. License

Under this license, you may use the Programs only with the device on which they are installed and transfer possession of the Programs and the device to another party.

If you transfer the Programs, you must transfer a copy of this license and any other documentation to the other party. Your license is then terminated. The other party agrees to these terms and conditions by its first use of the Program.

You may not:

- 1 use, copy, modify, merge, or transfer copies of the Program except as provided in this license;
- 2 reverse assemble or reverse compile the Program; or
- 3 sublicense, rent, lease, or assign the Program.

#### 2. Limited Warranty

The Programs are provided "AS IS."

THERE ARE NO OTHER WARRANTIES COVERING THE PROGRAMS (OR CONDITIONS), EXPRESS OR IMPLIED, INCLUDING, BUT NOT LIMITED TO, THE IMPLIED WARRANTIES OF MERCHANTABILITY AND FITNESS FOR A PARTICULAR PURPOSE.

---

Some jurisdictions do not allow the exclusion of implied warranties, so the above exclusion may not apply to you.

### 3. Limitation of Remedies

IBM's entire liability under this license is the following:

For any claim (including fundamental breach), in any form, related in any way to this license, IBM's liability will be for actual damages only and will be limited to the greater of:

- 1 the equivalent of U.S. \$25,000 in your local currency; or
- 2 IBM's then generally available license fee for the Program

This limitation will not apply to claims for bodily injury or damages to real or tangible personal property for which IBM is legally liable.

IBM will not be liable for any lost profits, lost savings, or any incidental damages or other economic consequential damages, even if IBM, or its authorized supplier, has been advised of the possibility of such damages. IBM will not be liable for any damages claimed by you based on any third party claim. This limitation of remedies also applies to any developer of Programs supplied to IBM. IBM's and the developer's limitations of remedies are not cumulative. Such developer is an intended beneficiary of this Section. Some jurisdictions do not allow these limitations or exclusions, so they may not apply to you.

### 4. General

You may terminate your license at any time. IBM may terminate your license if you fail to comply with the terms and conditions of this license. In either event, you must destroy all your copies of the Program. You are responsible for payment of any taxes, including personal property taxes, resulting from this license. Neither party may bring an action, regardless of form, more than two years after the cause of action arose. If you acquired the Program in the United States, this license is governed by the laws of the State of New York. If you acquired the Program in Canada, this license is governed by the laws of the Province of Ontario. Otherwise, this license is governed by the laws of the country in which you acquired the Program.

## Typeface Trademark Acknowledgement

All resident fonts in this printer are licensed from Monotype Imaging Inc.

Helvetica, Palatino and Times are registered trademarks of Linotype-Hell AG. ITC Avant Garde Gothic, ITC Bookman, ITC ZapfChancery and ITC Zapf Dingbats are registered trademarks of International Typeface Corporation.



---

## Monotype Imaging License Agreement

- 1 “Software” shall mean the digitally encoded, machine readable, scalable outline data as encoded in a special format as well as the UFST Software.
- 2 You agree to accept a non-exclusive license to use the Software to reproduce and display weights, styles and versions of letters, numerals, characters and symbols (“Typefaces”) solely for your own customary business or personal purposes at the address stated on the registration card you return to Monotype Imaging. Under the terms of this License Agreement, you have the right to use the Fonts on up to three printers. If you need to have access to the fonts on more than three printers, you need to acquire a multi-user license agreement which can be obtained from Monotype Imaging. Monotype Imaging retains all rights, title and interest to the Software and Typefaces and no rights are granted to you other than a License to use the Software on the terms expressly set forth in this Agreement.
- 3 To protect proprietary rights of Monotype Imaging, you agree to maintain the Software and other proprietary information concerning the Typefaces in strict confidence and to establish reasonable procedures regulating access to and use of the Software and Typefaces.
- 4 You agree not to duplicate or copy the Software or Typefaces, except that you may make one backup copy. You agree that any such copy shall contain the same proprietary notices as those appearing on the original.
- 5 This License shall continue until the last use of the Software and Typefaces, unless sooner terminated. This License may be terminated by Monotype Imaging if you fail to comply with the terms of this License and such failure is not remedied within thirty (30) days after notice from Monotype Imaging. When this License expires or is terminated, you shall either return to Monotype Imaging or destroy all copies of the Software and Typefaces and documentation as requested.
- 6 You agree that you will not modify, alter, disassemble, decrypt, reverse engineer or decompile the Software.
- 7 Monotype Imaging warrants that for ninety (90) days after delivery, the Software will perform in accordance with Monotype Imaging-published specifications, and the diskette will be free from defects in material and workmanship. Monotype Imaging does not warrant that the Software is free from all bugs, errors and omissions.
- 8 THE PARTIES AGREE THAT ALL OTHER WARRANTIES, EXPRESSED OR IMPLIED, INCLUDING WARRANTIES OF FITNESS FOR A PARTICULAR PURPOSE AND MERCHANTABILITY, ARE EXCLUDED.
- 9 Your exclusive remedy and the sole liability of Monotype Imaging in connection with the Software and Typefaces is repair or replacement of defective parts, upon their return to Monotype Imaging.

- 
- 10 IN NO EVENT WILL MONOTYPE IMAGING BE LIABLE FOR LOST PROFITS, LOST DATA, OR ANY OTHER INCIDENTAL OR CONSEQUENTIAL DAMAGES, OR ANY DAMAGES CAUSED BY ABUSE OR MISAPPLICATION OF THE SOFTWARE AND TYPEFACES.
  - 11 Massachusetts U.S.A. law governs this Agreement.
  - 12 You shall not sublicense, sell, lease, or otherwise transfer the Software and/or Typefaces without the prior written consent of Monotype Imaging.
  - 13 Use, duplication or disclosure by the Government is subject to restrictions as set forth in the Rights in Technical Data and Computer Software clause at FAR 252-227-7013, subdivision (b)(3)(ii) or subparagraph (c)(1)(ii), as appropriate. Further use, duplication or disclosure is subject to restrictions applicable to restricted rights software as set forth in FAR 52.227-19 (c)(2).
  - 14 YOU ACKNOWLEDGE THAT YOU HAVE READ THIS AGREEMENT, UNDERSTAND IT, AND AGREE TO BE BOUND BY ITS TERMS AND CONDITIONS. NEITHER PARTY SHALL BE BOUND BY ANY STATEMENT OR REPRESENTATION NOT CONTAINED IN THIS AGREEMENT. NO CHANGE IN THIS AGREEMENT IS EFFECTIVE UNLESS WRITTEN AND SIGNED BY PROPERLY AUTHORIZED REPRESENTATIVES OF EACH PARTY. BY OPENING THIS DISKETTE PACKAGE, YOU AGREE TO ACCEPT THE TERMS AND CONDITIONS OF THIS AGREEMENT.

## Safety Information

**DANGER: CLASS 3B LASER RADIATION WHEN OPEN. AVOID DIRECT EXPOSURE TO BEAM.**

### Radio Frequency Transmitter

This machine contains the transmitter module. We, the manufacturer (Kyocera Corporation) hereby declare that this equipment (page printer), model FS-6950DN is in compliance with the essential requirements and other relevant provisions of Directive 1999/5/EC.

### Radio Tag Technology

In some countries the radio tag technology used in this equipment to identify the toner container may be subject to authorization and the use of this equipment may consequently be restricted.

## Caution Labels

The printer bears any of the following labels.

**DANGER** • CLASS 3B LASER RADIATION WHEN OPEN.  
AVOID DIRECT EXPOSURE TO BEAM.

**ATTENTION** • CLASSE 3B RAYONNEMENT LASER EN CAS D'OUVERTURE.  
EXPOSITION DANGEREUSE AU FASCICUL.

**VORSICHT** • KLASSE 3B LASERSTRahlung, WENN ABDECKUNG GEÖFFNET.  
NICHT DEM STRahl, AUSSETZEN.

**ATTENZIONE** • CLASSE 3B RADIAZIONE LASER IN CASO DI APERTURA.  
EVITARE L'ESPOSIZIONE AL FASCIO.

**PRECAUCION** • CLASSE 3B RADIAZIONE LASER CUANDO SE ABRE.  
EVITAR EXPOSERSE AL RAYO.

**VARO!** • AVATTAESBA OLET ALTTINA LUOKAN 3B LASERSÄTELYLLÄ.  
ÄLÄ KATSO SÄTELYSÄÄ.

警告・开盖时、有盖激光光束 会直接照射眼睛。  
警告・开盖时 有盖 有盖激光光束 会直接照射眼睛。  
注意・CLASS 3B 激光 射线 照射 避免 直视 激光。  
警告・このカバーの内部ではクラス3Bレーザー光が放射されています。  
レーザーを直接見るようにしないでください。

**CAUTION** HOT SURFACE

**ACHTUNG** HEISSE OBERFLÄCHE

**ATTENTION** TEMPERATURE ÉLEVÉE

**ATTENZIONE** SUPERFICIE CHE SCOTTA

고온주의 高温注意

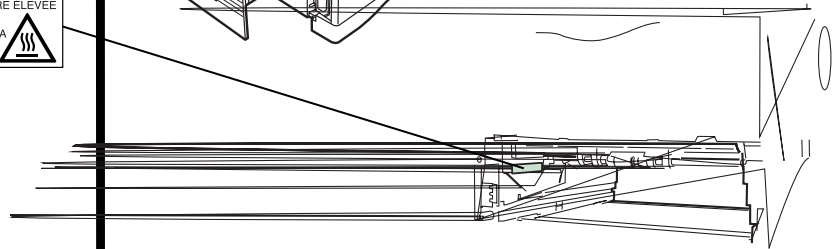
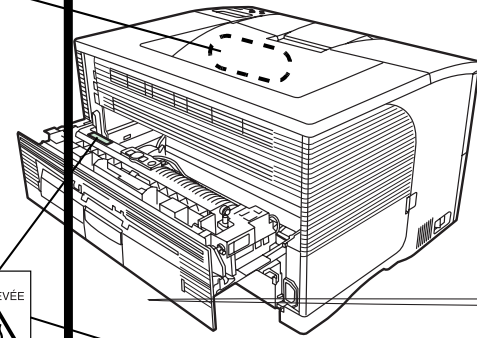

220-240V  
50/60Hz

KYOCERA MITA Corporation

UL Product Safety

GS

CE

ENERGY

ACN00932441 2011

REMOVE POWER CORD BEFORE SERVICE

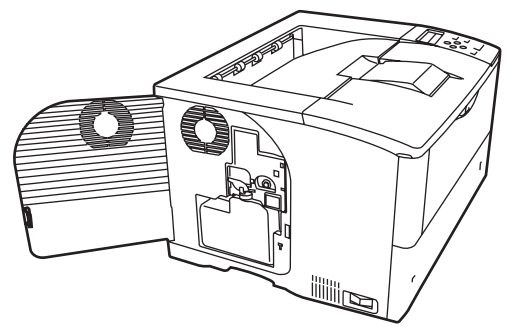

DESIGNED IN JAPAN / ASSEMBLED IN CHINA

## Ozone Concentration

The printers generate ozone gas (O<sub>3</sub>) which may concentrate in the place of installation and cause an unpleasant smell. To minimize the concentration of ozone gas to less than 0.1 ppm, we recommend you not to install the printer in a confined area where ventilation is blocked.

---

## CE Marking Directive

According to Council Directive 89/336/EEC, 73/23/EEC, and 1999/5/EC

Manufacturer: Kyocera Mita Corporation Tamaki Plant

Manufacturer's address: 704-19, Nojino, Tamaki-cho, Watarai-gun, Mie-ken 519-0497, Japan

Declares that the product

Product name: Page Printer

Model number: FS-6950DN (as tested with enhancement optional unit; Paper Feeder PF-430)

Conforms to the following product specifications:

EN 55 022:1998+A1:2000+A2:2003 Class B

EN 61 000-3-2:2000

EN 61 000-3-3:1995+A1:2001

EN 55 024:1998+A1:2001+A2:2003

EN 60 950:2000

EN 60 825-1:1994+A1+A2

EN 300330-1

EN 300330-2

The manufacturer and its merchandising companies retain the following technical documentation in anticipation of the inspection that may be conducted by the authorities concerned.

User's instruction that conforms to the applicable specifications.

Technical drawings.

Descriptions of procedures that guarantee conformity.

Other technical information.

---

## Declaration of Conformity (Australia)

Manufacturer: Kyocera Mita Corporation Tamaki Plant  
Manufacturer's address: 704-19, Nojino, Tamaki-cho, Watarai-gun, Mie-ken 519-0497, Japan

declares that the product

Product name: Page Printer  
Model name: FS-6950DN

Description of devices: This Page Printer Model FS-6950DN is the 32 ppm, A4 size and utilized plain paper; dry toner; etc. The printer can be equipped with several enhancement optional units as a paper feeder as PF-430.

conforms to the following product specifications:

AS/NZS 3548: 1995 (EN 55 022: 1998 Class B)

AS/NZS 4268: 2003

IEC60950: 1999 (EN 60 950: 2000)

The manufacturer and its merchandising companies retain the following technical documentation in anticipation of the inspection that may be conducted by the authorities concerned.

User's instruction that conforms to the applicable specifications  
Technical drawings  
Descriptions of procedures that guarantee conformity  
Other technical information

The manufacturer has been employed with ISO9001 scheme. JQA and BS have attested the manufacturer.

Kyocera Mita Australia Pty., Ltd.  
6-10 Talavera Road, North Ryde, NSW 2113, Australia  
Telephone: +61 2-9888-9999  
Fax: +61 2-9888-9588

## ISO 7779

Maschinenlärminformations-Verordnung 3. GPSGV: Der höchste Schalldruckpegel beträgt 70 dB (A) oder weniger gemäß EN ISO 7779.

## Disclaimer

Kyocera Mita will not be liable to customers or any other person or entity for any loss or damage caused or alleged to be caused directly or indirectly by equipment sold or furnished by us, including but not limited to, any interruption of service, loss of business or anticipatory profits, or consequential damages resulting from the use or operation of the equipment or software.

---

## Energy Star Program



As an ENERGY STAR Partner, we have determined that this product meets the ENERGY STAR guidelines for energy efficiency.

The basic objective of the ENERGY STAR Program is to reduce environmental pollution by encouraging the manufacture and sale of equipment that uses energy more efficiently.

This printer is equipped with a sleep timer function that conforms with the standards of the ENERGY STAR Program. This function makes it possible to reduce the amount of electrical power consumed by the printer. For maximum power savings, turn off the printer's power supply when not using the printer for extended periods of time.

For details on the sleep timer function and printer power consumption, refer to this manual.

Initial settings of the sleep timer function and power saved using the sleep timer function:

|                                 |                         |
|---------------------------------|-------------------------|
| Initial Auto Sleep Setting      | 15 minutes (60 minutes) |
| Power Consumption in Auto Sleep | 4.9W (40W)              |

( ): ENERGY STAR program guideline

## Group for Energy Efficient Appliances (GEEA)



The goal of GEEA is efficient use of energy. This product has a high-efficiency profile and meets the criteria for receiving the GEEA-Label.

|  |                         |
|--|-------------------------|
| Initial Auto Sleep Setting                       | 15 minutes (60 minutes) |
| Power Consumption<br>- Power off<br>- Auto Sleep | 0W (1W)<br>4.9W (15W)   |

( ): GEEA criteria

---

## Please read this Operation Guide before using the machine. Keep it close to the machine for easy reference.

The sections of this guide and parts of the machine marked with symbols are safety warnings meant to protect the user, other individuals and surrounding objects, and ensure correct and safe usage of the machine. The symbols and their meanings are indicated below.



**DANGER:** Indicates that serious injury or even death will very possibly result from insufficient attention to or incorrect compliance with the related points.



**WARNING:** Indicates that serious injury or even death may result from insufficient attention to or incorrect compliance with the related points.



**CAUTION:** Indicates that personal injury or mechanical damage may result from insufficient attention to or incorrect compliance with the related points.

### Symbols

The following symbols indicate that the related section includes safety warnings. Specific points of attention are indicated inside the symbol.



.... [General warning]



.... [Warning of danger of electrical shock]



.... [Warning of high temperature]

The following symbols indicate that the related section includes information on prohibited actions. Specifics of the prohibited action are indicated inside the symbol.



.... [Warning of prohibited action]



.... [Disassembly prohibited]

---

The following symbols indicate that the related section includes information on actions which must be performed. Specifics of the required action are indicated inside the symbol.



.... [Alert of required action]



.... [Remove the power plug from the outlet]



.... [Always connect the machine to an outlet with a ground connection]

Please contact your service representative to order a replacement if the safety warnings in this Operation Guide are illegible or if the guide itself is missing. (fee required)



## Installation Precautions

### Environment



#### CAUTION:

Avoid placing the machine on or in locations which are unstable or not level. Such locations may cause the machine to fall down or fall over. This type of situation presents a danger of personal injury or damage to the machine.



Avoid locations with humidity or dust and dirt. If dust or dirt become attached to the power plug, clean the plug to avoid the danger of fire or electrical shock.



Avoid locations near radiators, heaters, or other heat sources, or locations near flammable items, to avoid the danger of fire.



To keep the machine cool and facilitate changing of parts and maintenance, allow access space as shown below. Leave





---

adequate space, especially around the vents, to allow air to be properly ventilated out of the printer.

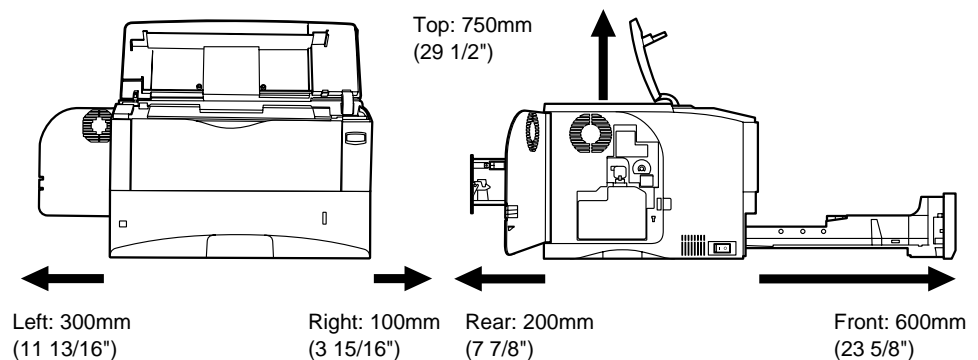

## Other Precautions

Adverse environmental conditions may affect the safe operation and performance of the machine. Install in an air-conditioned room (recommended room temperature: around 23°C, humidity: around 60% RH), and avoid the following locations when selecting a site for the machine.

- Avoid locations near a window or with exposure to direct sunlight.
- Avoid locations with vibrations.
- Avoid locations with drastic temperature fluctuations.
- Avoid locations with direct exposure to hot or cold air.
- Avoid poorly ventilated locations.

During printing, some ozone is released, but the amount does not cause any ill effect to one's health. If, however, the printer is used over a long period of time in a poorly ventilated room or when printing an extremely large number of copies, the smell may become unpleasant. To maintain the appropriate environment for print work, it is suggested that the room be properly ventilated.

---

## Power Supply/Grounding the Machine

### **WARNING:**

Do not use a power supply with a voltage other than that specified. Avoid multiple connections in the same outlet. These types of situations present a danger of fire or electrical shock.

Plug the power cord securely into the outlet. If metallic objects come in contact with the prongs on the plug, it may cause a fire or electric shock.

Always connect the machine to an outlet with a ground connection to avoid the danger of fire or electrical shock in case of an electric short. If an earth connection is not possible, contact your service representative.

### **Other Precautions**

Connect the power plug to the closest outlet possible to the machine.

The power supply cord is used as the main disconnect device. Ensure that the socket/outlet is located/installed near the equipment and is easily



## Precautions for Use

### Cautions when Using the Machine



#### WARNING:

Do not place metallic objects or containers with water (flower vases, flower pots, cups, etc.) on or near the machine. This situation presents a danger of fire or electrical shock should they fall inside.



Do not remove any of the covers from the machine as there is a danger of electrical shock from high voltage parts inside the machine.



Do not damage, break or attempt to repair the power cord. Do not place heavy objects on the cord, pull it, bend it unnecessarily or cause any other type of damage. These types of situations present a danger of fire or electrical shock.



Never attempt to repair or disassemble the machine or its parts as there is a danger of fire, electrical shock or damage to the laser. If the laser beam escapes, there is a danger of it causing blindness.



If the machine becomes excessively hot, smoke appears from the machine, there is an odd smell, or any other abnormal situation occurs, there is a danger of fire or electrical shock. Turn the power switch off (O) immediately, be absolutely certain to remove the power plug from the outlet and then contact your service representative.



If anything harmful (paper clips, water, other fluids, etc.) falls into the machine, turn the power switch off (O) immediately. Next, be absolutely certain to remove the power plug from the outlet to avoid the danger of fire or electrical shock. Then contact your service representative.



Do not remove or connect the power plug with wet hands, as there is a danger of electrical shock.



Always contact your service representative for maintenance or repair of internal parts.





## CAUTION

Do not pull the power cord when removing it from the outlet. If the power cord is pulled, the wires may become broken and there is a danger of fire or electrical shock. (Always grasp the power plug when removing the power cord from the outlet.)

Always remove the power plug from the outlet when moving the machine. If the power cord is damaged, there is a danger of fire or electrical shock.



If the machine will not be used for a short period of time (overnight, etc.), turn the power switch off (O). If it will not be used for an extended period of time (vacations, etc.), remove the power plug from the outlet for safety purposes during the time the machine is not in use.



Always hold the designated parts when lifting or moving the machine.



For safety purposes, always remove the power plug from the outlet when performing cleaning operations.



If dust accumulates within the machine, there is a danger of fire or other trouble. It is therefore recommended that you consult with your service representative in regard to cleaning of internal parts. This is particularly effective if accomplished prior to seasons of high humidity. Consult with your service representative in regard to the cost of cleaning the internal parts of the machine.



## Other Precautions

Do not place heavy objects on the machine or cause other damage to the machine.

Do not open the upper front cover, turn off the power switch, or pull out the power plug during copying.

When lifting or moving the machine, contact your service representative.

Do not touch electrical parts, such as connectors or printed circuit boards. They could be damaged by static electricity.

Do not attempt to perform any operations not explained in this handbook.

Use shielded interface cables.



## CAUTION

Use of controls or adjustments or performance of procedures other than those specified herein may result in hazardous radiation exposure.

### Cautions when Handling Consumables



## CAUTION

Do not attempt to incinerate the Toner Container. Dangerous sparks may cause burns.



Keep the Toner Container out of the reach of children.



If toner happens to spill from the Toner Container, avoid inhalation and ingestion, as well as contact with your eyes and skin.



- If you do happen to inhale toner, move to a place with fresh air and gargle thoroughly with a large amount of water. If coughing develops, contact a physician.
- If you do happen to ingest toner, rinse your mouth out with water and drink 1 or 2 cups of water to dilute the contents of your stomach. If necessary, contact a physician.
- If you do happen to get toner in your eyes, flush them thoroughly with water. If there is any remaining tenderness, contact a physician.
- If toner does happen to get on your skin, wash with soap and water.

Do not attempt to force open or destroy the Toner Container.



### Other Precautions

After use, always dispose of the Toner Container in accordance with Federal, State and Local rules and regulations.

Store all consumables in a cool, dark location.

If the machine will not be used for an extended period of time, remove the paper from the cassette, return it to its original package and reseal it.

---

## About the Operation Guide

This Operation Guide has the following chapters:

*Chapter 1 - Machine Parts*

This chapter explains the names of parts.

*Chapter 2 - Printing Operation*

This chapter explains how to print from your workstation.

*Chapter 3 - Maintenance*

This chapter explains how to replace the toner container and how to care for your printer.

*Chapter 4 - Troubleshooting*

This chapter explains how to handle printer problems that may occur, such as paper jams.

*Chapter 5 - Specifications*

This chapter lists the printer's specifications.

## Conventions

This manual uses the following conventions.

| Convention              | Description   | Example   |
|-------------------------|---|---|
| <b>Italic Typeface</b>  | Used to emphasize a key word, phrase or references to additional information.           | Close the <i>top cover</i> .<br>Refer to <i>Toner Container Replacement on page 3-3</i> .     |
| <b>Courier Typeface</b> | Used to denote messages or names displayed on the operation panel.                      | Replace the waste toner box when the <code>Check waste toner box</code> message is displayed. |
| <b>Bold Typeface</b>    | Used to denote operation panel keys.  | Press <b>[Menu]</b> .   |
| <b>Notes</b>            | Used to provide additional or useful information about a function or feature.           | <b>NOTE:</b> For information about storing the pin, refer to step 10.                         |
| <b>Important</b>        | Use to provide important information.   | <b>IMPORTANT:</b> Ensure paper is not folded, curled, or damaged.                             |
| <b>Caution</b>          | Cautions are statements that suggest <i>mechanical</i> damage as a result of an action. | <b>CAUTION:</b> Do not pull the cassette out when holding the front of the machine.           |
| <b>Warning</b>          | Used to alert users to the possibility of <i>personal</i> injury.                       | <b>WARNING:</b> High voltage is present in the charger section.                               |

# 1 Machine Parts

This section provides explanations and illustrations for you to determine the parts and their functions. Try to be familiar with the names and functions of these parts for correct use and optimal performance.

This chapter contains explanations on the following topics:

- Components at the Front of the Printer ..... 1-2
- Components at the Left of the Printer and Internal Components ..... 1-2
- Components at the Rear of the Printer..... 1-3

## Components at the Front of the Printer

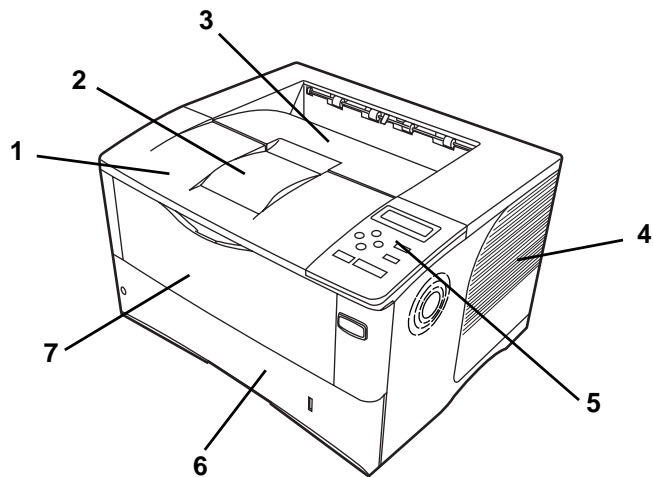

- 1 Top Cover
- 2 Paper Stopper
- 3 Top Tray
- 4 Right Cover
- 5 Operation Panel
- 6 Paper Cassette
- 7 MP (Multi-Purpose) Tray

## Components at the Left of the Printer and Internal Components

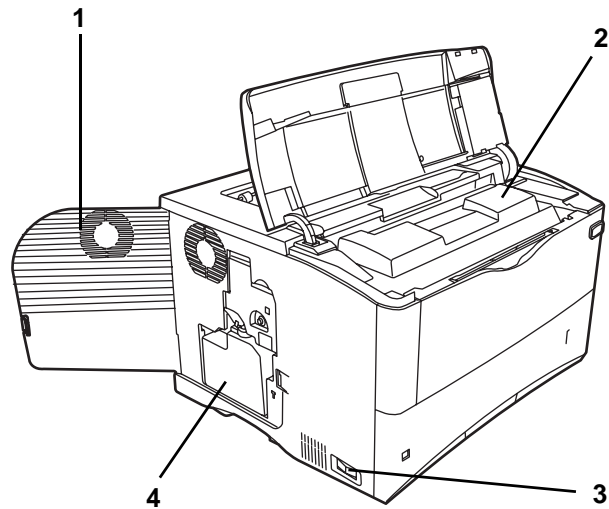

- 1 Left Cover
- 2 Toner Container
- 3 Power Switch
- 4 Waste Toner Box



## Components at the Rear of the Printer

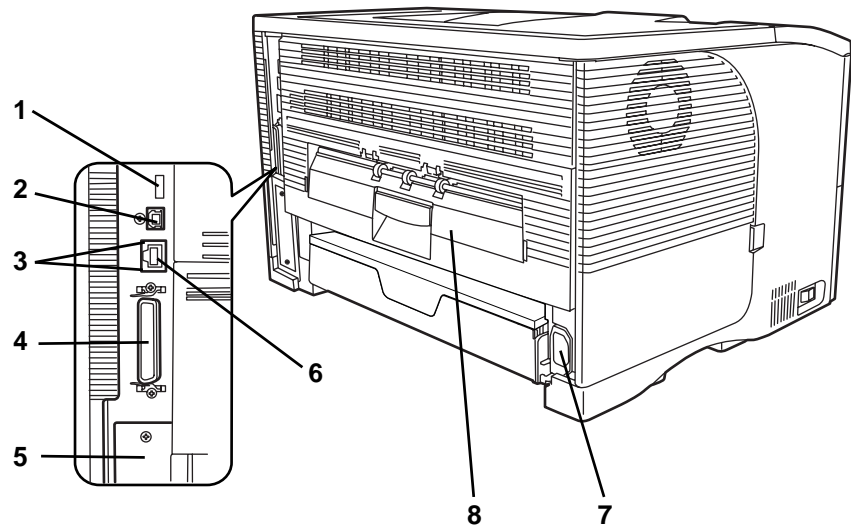

- 1 USB Memory Connector
- 2 USB Interface Connector
- 3 Network indicators
- 4 Parallel Interface Connector
- 5 Option Interface Slot (Network/Serial/CF card/Microdrive)
- 6 Network Interface Connector
- 7 Power Cord Connector
- 8 Rear Unit



## 2 Printing Operation

This chapter contains explanations on the following topics:

- Loading Printer Driver ..... 2-2
- Printing from Application Software ..... 2-3

## Loading Printer Driver

Ensure the printer is plugged in and connected to the PC before installing the printer driver from the CD-ROM.

- 1 Switch on the PC and activate Windows.

---

**NOTE:** If the Welcome to the Found New Hardware Wizard dialog box displays, select Cancel.

---

- 2 Insert the CD-ROM supplied with the printer into the optical drive of the PC.

- 3 The installation program launches.

---

**NOTE:** If the installation program fails to launch, use Windows Explorer to access the CD-ROM and select Setup.exe.

---

- 4 Perform the procedures displayed on the installation program to install the KX DRIVER.

## Printing from Application Software

The steps required to print a document created with an application are explained below. You can select the printing *Paper Size* and *Output Destination*.

- 1 Load the paper required into the paper cassette.
- 2 From the application *File* menu, select **Print**. The *Print* dialog box displays.
- 3 Click the drop down list of printer names. All the printers installed in Windows are listed. Click the name of the machine.
- 4 Use **Number of copies** to enter the number of prints required. Up to 999 copies can be entered.

For Microsoft Word, we recommend that you click **Options** and specify **Use printer settings** for the **Default tray**.

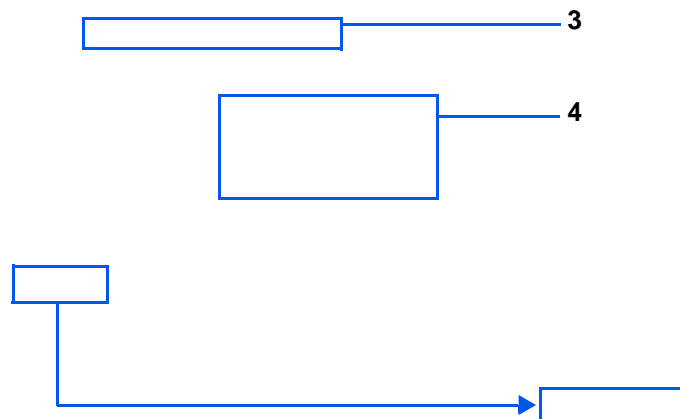

- 5 To start printing, click **OK**.



# 3 Maintenance

This chapter contains explanations on the following topics:

- General Information..... 3-2
- Toner Container Replacement..... 3-3
- Cleaning the Printer..... 3-8

## General Information

This chapter describes basic maintenance tasks you can perform on the printer. You can replace the following component according to the printer's display:

- Toner Kits
- Waste Toner Box

Also, the internal parts need periodic cleaning.



## Toner Container Replacement

### Frequency of toner container replacement

The life of the toner containers depends on the amount of toner required to accomplish your printing jobs. Assuming paper of A4 size, an average toner coverage of approximately 5% and EcoPrint mode turned off, the toner container will need replacing approximately once every 15,000 pages.

You can print a status page to check how much toner remains in the toner

In either case, replace the toner container, refer to *Toner Container Replacement* on page 3-3.

## Replacing the Toner Container

---

**NOTE:** During toner container replacement, temporarily put storage media and computer supplies (such as floppy disks) away from around the toner container. This is to avoid damaging media by the magnetism of toner.

---

This section explains how to replace the toner container. When replacing the toner container, always replace the waste toner box at the same time. If this box is full, the printer may be damaged or contaminated by the waste toner that may spill over the box.

---

**NOTE:** You do not have to turn printer power off before starting the replacement. Any data that may be under printing process in the printer will be deleted if you turn printer power off.

---

- 1 Open the top cover.

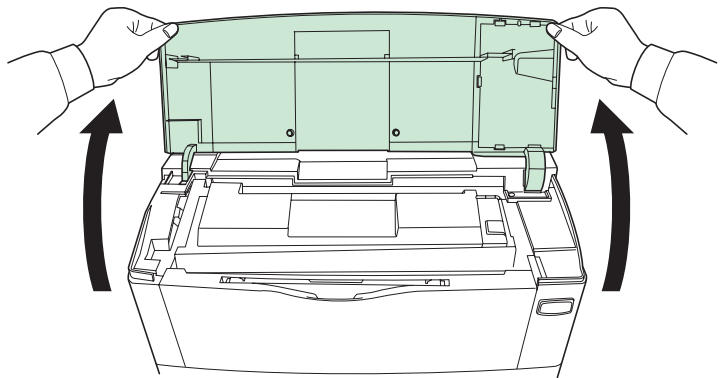

- 2 Push lock lever to the right and pull out the toner container.

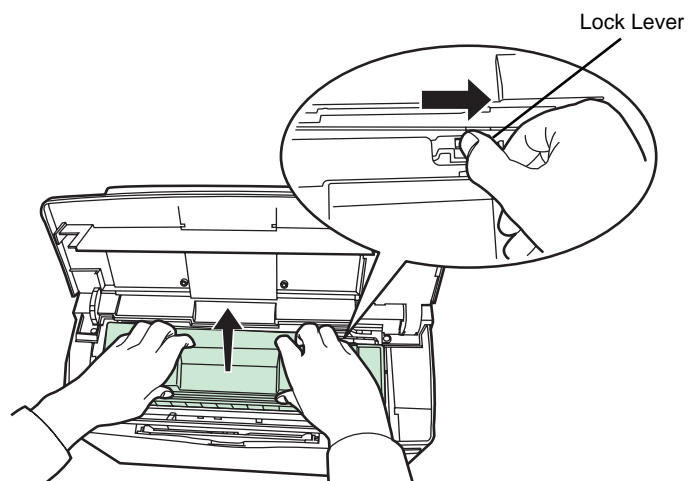

- 3** Put the old toner container in the plastic bag (contained in the toner kit) and discard it later according to the local code or regulations for waste disposal.

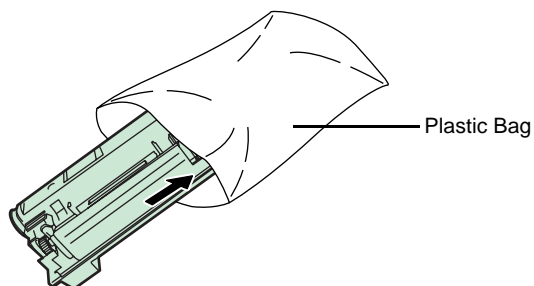

- 4** Take the new toner container out of the toner kit.

- 5** Shake the new toner container 10 times or more as shown in the figure in order to distribute the toner evenly inside the container.

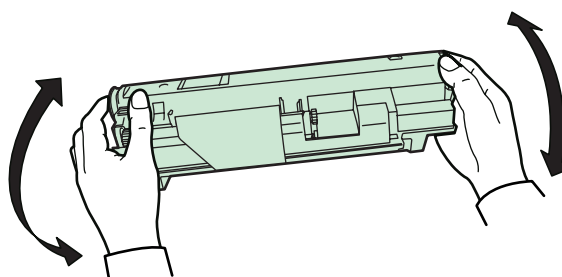

- 6** Remove the label from the toner container.

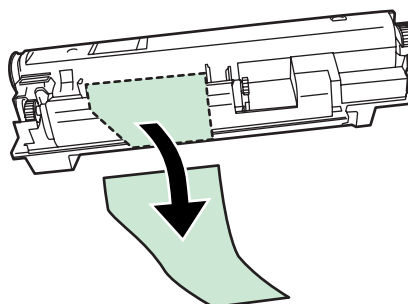

- 7** Set the new toner container in the printer and push down on the top of the toner container to install it firmly in place as shown in the figure below.

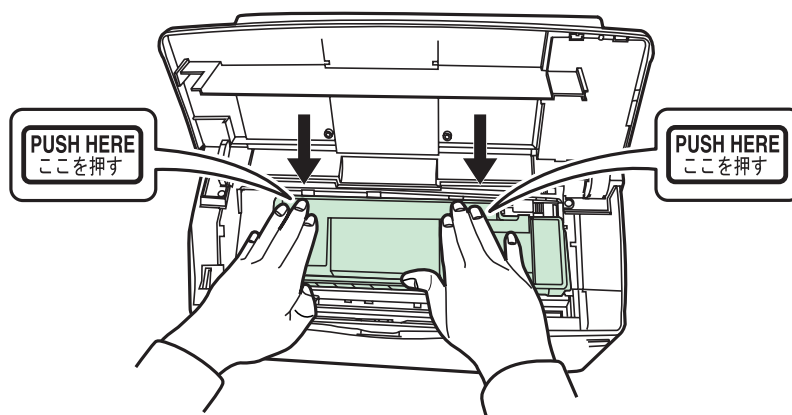

- 8 Close the top cover.

Proceed to the next section.

## Replacing the Waste Toner Box

When replacing the toner container, the used waste toner box in the printer should also be replaced with the new one from the new toner kit. A new waste toner box is included with the toner kit. The printer will not operate without replacing the waste toner box.

- 1 Open the left cover. While holding the waste toner box, press the lock lever and then gently remove the waste toner box.

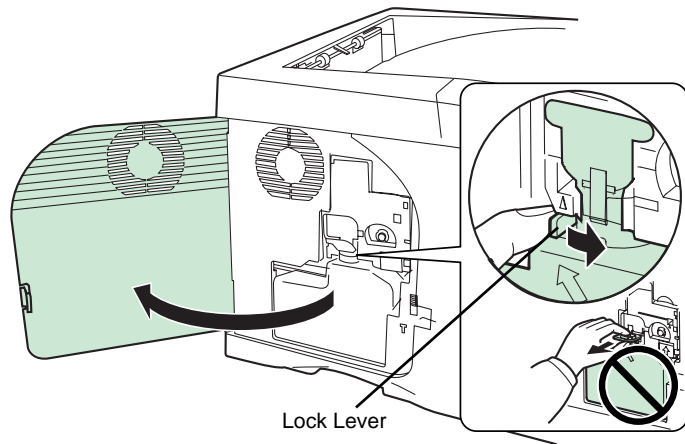

**NOTE:** Remove the waste toner box as gently as possible so as not to scatter the toner inside. Do not let the opening of the waste toner box face downward.

- 2 Close the cap to the old waste toner box after removing the box from the printer.

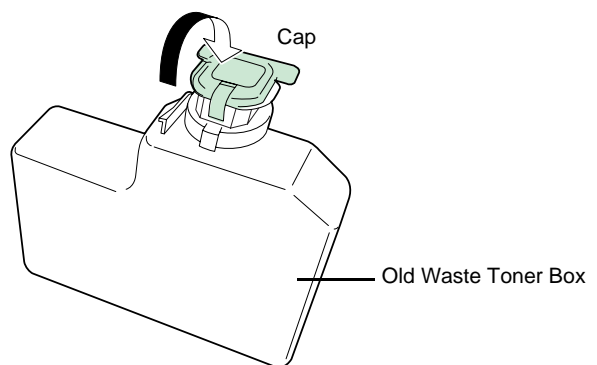

- 3 To prevent toner from spilling, put the old waste toner box in the plastic bag (contained in the toner kit) and discard it later according to the local code or regulations for waste disposal.

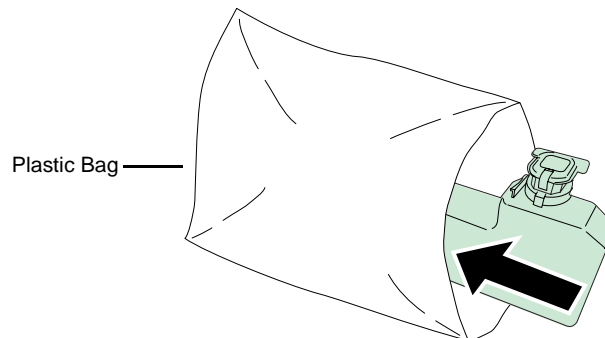

- 4 Open the cap of the new waste toner box.

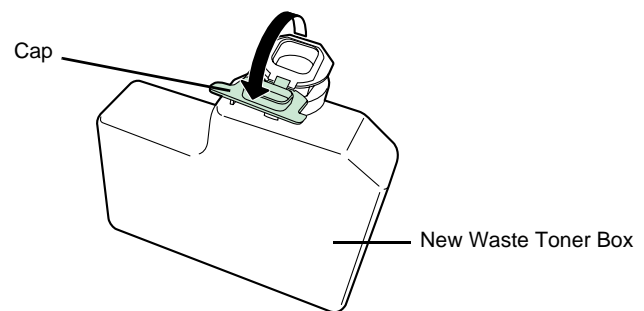

- 5 Insert the new waste toner box as shown in the figure below. When the box is set correctly, it will snap into place.

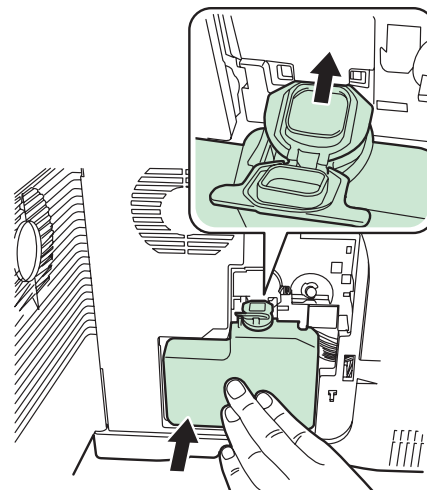

- 6 Make sure that the waste toner box is correctly inserted and close the left cover.

After replacing the toner containers and the waste toner box, clean the internal parts. For instructions, refer to *Cleaning the Printer* on page 3-8.

## Cleaning the Printer

To avoid print quality problems, the interior of the printer must be cleaned.

- 1 Open the top cover and MP tray.
- 2 Lift the developer unit together with the toner container out of the printer.

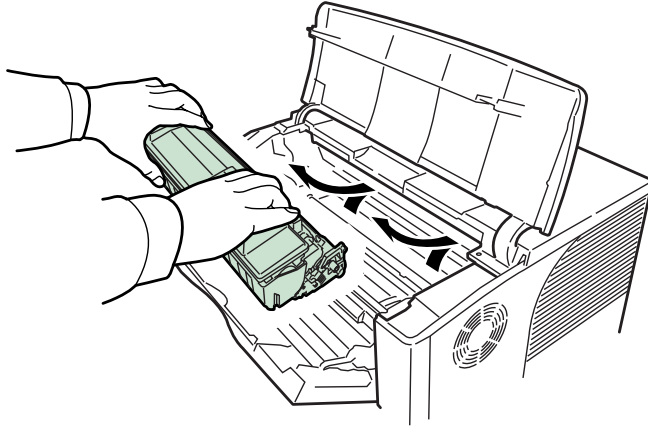

- 3 Use a lint free cloth to clean dust and dirt away from the metal Registration Roller (metal).

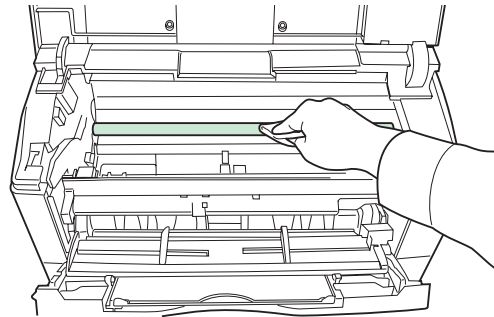

- 4 Insert the developer unit together with the toner container, back into the machine.

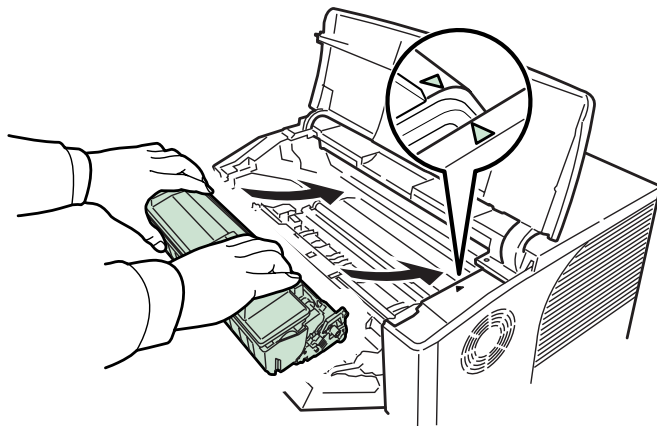

- 5 Close the top cover and MP tray.

# 4 Troubleshooting

This chapter contains explanations on the following topics:

- General Guidelines..... 4-2
- Print Quality Problems..... 4-3
- Error Messages ..... 4-5
- Clearing Paper Jams.....4-11

If a problem cannot be corrected, contact your service technician.

## General Guidelines

The table below provides basic solutions for problems you may encounter with the printer. We suggest you consult this table to troubleshoot the problems before calling for service.

| Symptom  | Check Items  | Corrective Action   |
|--|--|---|
| Print quality is not good.   | Refer to <i>Print Quality Problems</i> on page 4-3.                  |   |
| Paper is jammed.   | Refer to <i>Clearing Paper Jams</i> on page 4-11.                    |   |
| Nothing lights on the operation panel even when power is turned on and the fan makes no noise. | Check that the power cord is properly plugged into the power outlet. | Turn off the printer's power, plug in the power cord securely, and try turning on the printer's power again.  |
|  | Check that the power switch is in the On (I) position.               | Set the power switch to the On position.  |
| The printer prints a status page, but does not print jobs from the computer.                   | Check the printer cable or the interface cable.                      | Connect both ends of the printer cable securely. Try replacing the printer cable or the interface cable.  |
|  | Check program files and application software.                        | Try printing another file or using another print command. If the problem occurs only with a specific file or application, check the printer driver settings for that application. |

### Tips

Printer problems may be solved easily by following the tips below. When you have encountered a problem that following the above guidelines will not solve, try the following:

- Turn the printer power off and wait for several seconds. Then, turn on the printer.
- Reboot the computer which sends the print jobs to the printer.
- Obtain and use the latest version of the printer driver. The latest versions of printer drivers and utilities are available at: <http://www.kyoceramita.com/download/>.
- Make sure that the procedures for printing are correctly followed in the application software. Consult the documentation supplied with the application software.
- If the printer prints garbage characters or stalls when the computer is turned on, particularly when the printer is connected to the computer under Windows 98 via the parallel port, rename device driver file `drvppqt.vxd`. This file may be located in `Windows\System\losubsys` or `Arcada\System` folder. For technical details, visit Microsoft web site for the device driver.



## Print Quality Problems

The tables and diagrams in the following sections define print quality problems and the corrective action you can conduct to solve the problems. Some solutions may require cleaning or replacing parts of the printer.

If the suggested corrective action will not solve the problem, call for service.

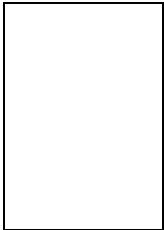
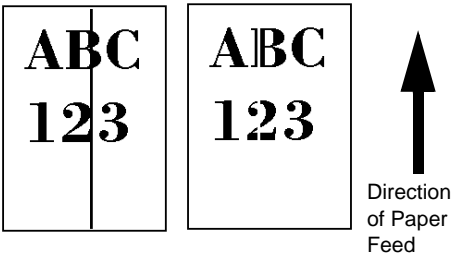
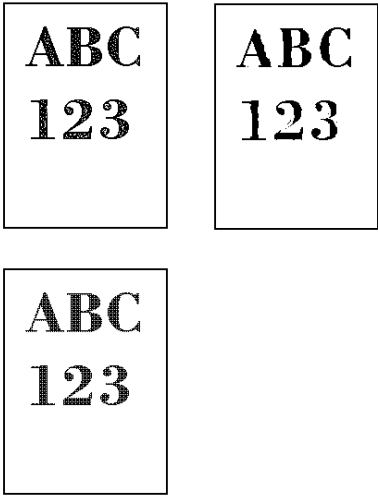
| Printed Results  | Corrective Action   |
|--|---|
| <p><b>Completely blank printout</b></p>         | <p>Check the toner container.<br/>Open the printer top cover and check that the toner container is correctly installed in the printer. For more information on installing the toner container, refer to <i>Toner Container Replacement on page 3-3</i>.</p> <hr/> <p>Check that the application software is correctly operated.</p>   |
| <p><b>Black or white vertical streaks</b></p>  | <p>Check the operation panel for toner.<br/>If the <b>Toner low</b> message is displayed, install a new toner kit. To replace the toner container, refer to <i>Toner Container Replacement on page 3-3</i>.</p>   |
| <p><b>Faint or blurred printing</b></p>       | <p>Check the EcoPrint setting.<br/>When this setting is On, switch it to off on the operation panel.</p> <hr/> <p>Make sure the paper type setting is correct the paper being used.</p> <hr/> <p>Check the operation panel. If the <b>Toner low</b> message is displayed, install a new toner kit. To replace toner, refer to <i>Toner Container Replacement on page 3-3</i>.</p> |

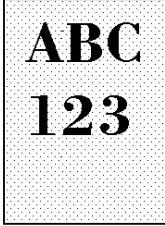
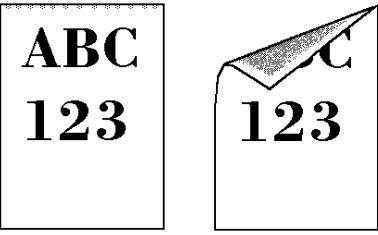
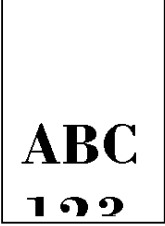
| Printed Results   | Corrective Action  |
|---|--|
| <p><b>Grey background</b></p>                            | <p>Check the operation panel.<br/>If the Toner low message is displayed and the Attention indicator is flashing, install a new toner kit. Refer to <i>Toner Container Replacement on page 3-3</i>.</p> <hr/> <p>Check the print density.<br/>Display the print density menu from the operation panel and select a lighter density setting.</p> |
| <p><b>Dirt on the top edge or back of the paper</b></p>  | <p>Clean the parts in the paper paths—such as the paper cassette, etc.</p>   |
| <p><b>Printing incomplete or out of position</b></p>   | <p>Check that the application software is correctly operated.</p> <hr/> <p>Refer to <i>Tips on page 4-2</i>.</p>   |

## Error Messages

The following table lists errors and maintenance messages that you can be dealt with by yourself. If `Call service` appears, turn off the printer, disconnect the power cord, and contact your service technician.

Some errors cause the alarm to sound. To stop the alarm, press **[Cancel]**.

| Message                      | Corrective Action   |
|------------------------------|---|
| Add paper MPTray             | The paper has run out in the paper source displayed. Supply paper according to the paper source displayed (paper cassettes, MP tray, or optional paper feeders.) This message is displayed alternately with messages indicating the printer status, such as, Ready, Please wait, Processing, Waiting, and FormFeed Time Out.    |
| Call service<br>F###         | F### represents a controller error (#=0, 1, 2, ...). Call for service. The printer does not operate when this message is displayed.   |
| Call service<br>####:0123456 | #### represents a mechanical error (#=0, 1, 2, ...). Call for service. The printer does not operate when this message is displayed. The total number of pages printed is also indicated, e.g. 0123456.  |
| Cassette #<br>not loaded     | The corresponding paper cassette is not installed. Install the cassette. The cassette number can be 1 (topmost) to 5 (bottom).  |
| Check waste<br>toner box     | This message warns following two cases. Install the new waste toner box. The waste toner box is not installed.<br>The waste toner box is full.  |
| Clean printer<br>Press GO    | Please clean the inside of the printer. Refer to <i>Cleaning the Printer on page 3-8</i> . This message will be displayed when replacing the toner container after the message <code>Replace toner</code> is displayed. After cleaning the inside of the printer, press <b>[GO]</b> and the printer will be ready for printing. |
| Close<br>left cover          | The left cover of the printer is open. Close the left cover.  |
| Close<br>rear unit           | The rear unit of the printer is open. Close the printer rear unit.  |
| Close<br>top cover           | The top cover of the printer is open. Close the printer top cover.  |
| Duplex disabled<br>Press GO  | You attempted to print with a paper size and paper type that cannot be used for duplex printing. Press <b>[GO]</b> to print onto one-side of the paper only.  |
| e-MPS not stored<br>Press GO | The e-MPS job cannot be stored because RAM disk is disabled, RAM disk size is insufficient, Microdrive is not installed, or Microdrive is full. Press <b>[GO]</b> to print error report.  |

| Message  | Corrective Action   |
|--|---|
| <div style="border: 1px solid black; padding: 2px;">                     Error. Power off<br/>F###                 </div>          | Turn the power switch off and then back on again. If this message still remains, turn the power switch off, and contact your service representative or authorized service center.   |
| <div style="border: 1px solid black; padding: 2px;">                     File not found<br/>Press GO                 </div>        | You have attempted to print a job that is not contained in the specified virtual mailbox, or the specified virtual mailbox is not found.<br>If Auto Error Clear is set to On, printing will be automatically resumed after a preset period of time.   |
| <div style="border: 1px solid black; padding: 2px;">                     Format error<br/>Hard disk                 </div>         | The Microdrive installed in the printer is not formatted, and therefore cannot be read or written.  |
| <div style="border: 1px solid black; padding: 2px;">                     Format error<br/>Memory card                 </div>       | The CompactFlash card inserted in the printer is not formatted, and therefore cannot be read or written.  |
| <div style="border: 1px solid black; padding: 2px;">                     Hard disk err ##<br/>Press GO                 </div>      | A Microdrive error has occurred. Look at the error code given in place of ## and refer to <i>Storage Error Codes on page 4-9</i> . To ignore the Microdrive error, press <b>[GO]</b> .  |
| <div style="border: 1px solid black; padding: 2px;">                     I/F occupied                 </div>                       | This message is displayed when you attempt to use the printer's operation panel to change the environmental settings on the interface from which data are presently being received.   |
| <div style="border: 1px solid black; padding: 2px;">                     ID error                 </div>                           | The user ID entered for a private job, or a stored job is not correct. Check the user ID that you specified on the printer driver.  |
| <div style="border: 1px solid black; padding: 2px;">                     Install MK                 </div>                         | Replace Maintenance Kit which is displayed on the message display. Replacement of the maintenance kit is necessary at every 300,000 pages of printing and requires professional servicing. Contact your service technician.   |
| <div style="border: 1px solid black; padding: 2px;">                     KPDL error ##<br/>Press GO                 </div>         | Current print processing cannot continue because of occurrence of KPDL error which is categorized by ##. To print out an error report, display > Print KPDL err(s) from the menu system, and select On. Press <b>[GO]</b> to resume printing. You can abandon printing by pressing <b>[Cancel]</b> .<br>If Auto Error Clear is set to On, printing will be automatically resumed after a preset period of time.   |
| <div style="border: 1px solid black; padding: 2px;">                     Load Cassette #<br/>(A4)/(PLAIN) †                 </div> | The paper cassette matching the paper size and paper type of the print job is empty. Load paper into the paper cassette as displayed in place of #. Press <b>[GO]</b> to resume printing.<br>If you want to print from a different paper source, press ▲ or ▼ to display Use alternative and you can change the source for paper feeding. After selecting a paper source and pressing <b>[Menu]</b> , Paper Handling > appears. By pressing the ▲, the paper type settings menu appears. After setting the correct paper type, press <b>[OK]</b> and printing starts. |

| Message                               | Corrective Action  |
|---------------------------------------|--|
| <p>Load MP Tray<br/>(A4)/(PLAIN)†</p> | <p>There is no paper cassette installed in the printer that matches the paper size and paper type of the print job. Set paper in the MP tray. Press <b>[GO]</b> to resume printing. (Note that feeding the paper having a paper size which does not match the current paper size from the MP tray can cause paper jam.)</p> <p>If you want to print from a different paper source, press <b>▲</b> or <b>▼</b> to display <i>Use alternative</i> and you can change the source for paper feeding. After selecting a paper source and pressing <b>[Menu]</b>, <i>Paper Handling &gt;</i> appears. By pressing the <b>▶</b>, the paper type settings menu appears. After setting the correct paper type, press <b>[OK]</b> and printing starts.</p> |
| <p>Memory overflow<br/>Press GO</p>   | <p>The total amount of data received by the printer exceeds the printer's internal memory. Try adding more memory. Press <b>[GO]</b> to resume printing. You can abandon printing by pressing <b>[Cancel]</b>.</p> <p>If Auto Error Clear is set to On, printing will be automatically resumed after a preset period of time.</p>  |
| <p>MemoryCard err##<br/>Press GO</p>  | <p>A CompactFlash card error has occurred. Look at the error code given in place of ## and refer to <i>Storage Error Codes on page 4-9</i>. To ignore the CompactFlash card error, press <b>[GO]</b>.</p>  |
| <p>MemoryCard err20</p>               | <p>The CompactFlash card is accidentally removed from the printer's slot during reading. Turn the power switch off and then back on again.</p>   |
| <p>Missing<br/>developer unit</p>     | <p>The developer unit is either not installed or incorrectly inserted. Insert the developer unit securely.</p>   |
| <p>No multi copies<br/>Press GO</p>   | <p>Multi copies cannot be printed because RAM disk is disabled or the Microdrive is not installed. There is no available RAM disk or Microdrive space. Delete unnecessary files. Press <b>[GO]</b> to print error report.</p>  |
| <p>Paper jam<br/>#####</p>            | <p>A paper jam has occurred. The location of the paper jam is indicated in place of the #'s. For details, refer to <i>Clearing Paper Jams on page 4-11</i>.</p>  |
| <p>Paper path error</p>               | <p>There is no paper cassette in the feeder, or the cassette is not inserted properly. After reinserting the paper cassette, you should be able to print. When two or more optional feeders are installed and the lowest one is selected, the same message will appear if any of the upper paper feeder and the printer cassette is improperly installed.</p>  |
| <p>Print overrun††<br/>Press GO</p>   | <p>The print job transferred to the printer was too complex to print on a page. Press <b>[GO]</b> to resume printing. (A page break may be automatically inserted in some places.)</p> <p>You can abandon printing by pressing <b>[Cancel]</b>.</p> <p>If Auto Error Clear is set to On, printing will be automatically resumed after a preset period of time.</p>   |
| <p>RAM disk error##<br/>Press GO</p>  | <p>A RAM disk error has occurred. Look at the error code given in place of ## and refer to <i>Storage Error Codes on page 4-9</i>. To ignore the RAM disk error, press <b>[GO]</b>.</p>  |

| Message                        | Corrective Action   |
|--------------------------------|---|
| Replace toner<br>Clean printer | Toner has run out in the toner container. Replace the toner container using a new toner kit. The printer does not operate when this message is displayed.   |
| Set paper<br>Press GO          | The MP tray is out of paper. Load paper and press <b>[GO]</b> . (Note that feeding the paper having a paper size which does not match the current paper size from the MP tray can cause paper jam.) |
| Toner low                      | Toner is running low. Replace the toner container using a new toner kit.  |
| Top tray<br>paper full         | The top tray has become full. You must remove all printed pages from the top tray. When the printer detects that the top tray is empty again, the printer will continue printing into the top tray. |
| Unknown Toner<br>Installed     | The toner container is not original. Use of original Kyocera Mita toner kits is highly recommended to prevent printer trouble and ensure the long life of the printer.                              |
| USB memory err##<br>Press GO   | An USB flash memory error has occurred. Look at the error code given in place of ## and refer to <i>Storage Error Codes on page 4-9</i> . To ignore the USB memory error, press <b>[GO]</b> .       |
| USB mem. removed<br>Press GO   | The USB flash memory is accidentally removed from the printer. To ignore the USB memory error, press <b>[GO]</b> . The message display returns to Ready.  |
| Virtual mailbox<br>full        | The storage area in the Microdrive for the virtual mailboxes is full. Print out accumulated jobs in the virtual mailboxes.  |
| Warning<br>image adapt         | Printing job cannot be done in current resolution because there is not enough internal memory. Try adding more memory or changing resolution.   |
| Warning<br>low memory          | The printer's internal memory is running low due to too many numbers of fonts and macros downloaded. Try deleting unnecessary fonts and macros.   |

† Messages separated by '( )/( )' are displayed alternately.

†† After this error has happened, page protect mode will be automatically turned on. To maintain optimum use of memory during printing, we recommend you manually turn off page protect mode.

## Storage Error Codes

### Microdrive Errors

| Code | Meaning   |
|------|---|
| 01   | Microdrive format error. If this error recurs even if the power has been turned off and then on, reformat the Microdrive.   |
| 02   | The disk system is not installed. Recheck the requirements for using the system and the devices.  |
| 04   | There is no available Microdrive space. Delete unnecessary files, etc., in order to free up space.  |
| 05   | The specified file does not exist in the Microdrive.  |
| 06   | There is no memory available to the Microdrive system. Increase the available memory.   |
| 10   | Formatting is not possible because host data is being spooled on the Microdrive. Wait until the Microdrive is ready, and then format.                                     |
| 85   | VMB: Alias error. The alias setting was lost, or the virtual tray corresponding to the alias does not exist. Set the alias again.   |
| 97   | The number of permanent code jobs that can be stored reached the limit value, and no more can be saved. Either delete some unnecessary jobs, etc., or increase the limit. |
| 98   | An unreadable page was found in a job (The job is damaged.).  |
| 99   | A print job for the specified ID does not exist in the Microdrive.  |

### CompactFlash Card/USB memory Errors

| Code | Meaning   |
|------|---|
| 01   | The printer does not support the CompactFlash card inserted.  |
| 02   | The CompactFlash card is not installed.   |
| 04   | The CompactFlash card is full and cannot hold further data. Purge unnecessary files or use a new CompactFlash card. |
| 05   | Specified file is not on the CompactFlash card/USB flash memory.  |
| 06   | Insufficient printer memory to support the CompactFlash card system. Expand printer memory.                         |

### RAM Disk Errors

| Code | Meaning  |
|------|--|
| 01   | Format error. Try turning the power off and on again.                              |
| 02   | RAM disk mode is OFF. Turn RAM disk mode On from the operation panel.              |
| 04   | No disk space. Purge unnecessary files.  |
| 05   | Specified file is not on disk.   |
| 06   | Insufficient printer memory to support the RAM disk system. Expand printer memory. |



## Clearing Paper Jams

If the paper jammed in the paper transport system, or no paper sheets were fed at all, the `Paper jam` message appears and the location of the paper jam (the component where the paper jam has occurred) is also indicated. The printer automatically goes off-line when this message is displayed. Remove jammed paper. After removing jammed paper, the printer will re-start printing.

### Possible Paper Jam Locations

The figure below explains the printer's paper paths including the options. The locations where paper jams might occur are also shown here, with each location explained in the table below. Paper jams can occur in more than one component on the paper paths.

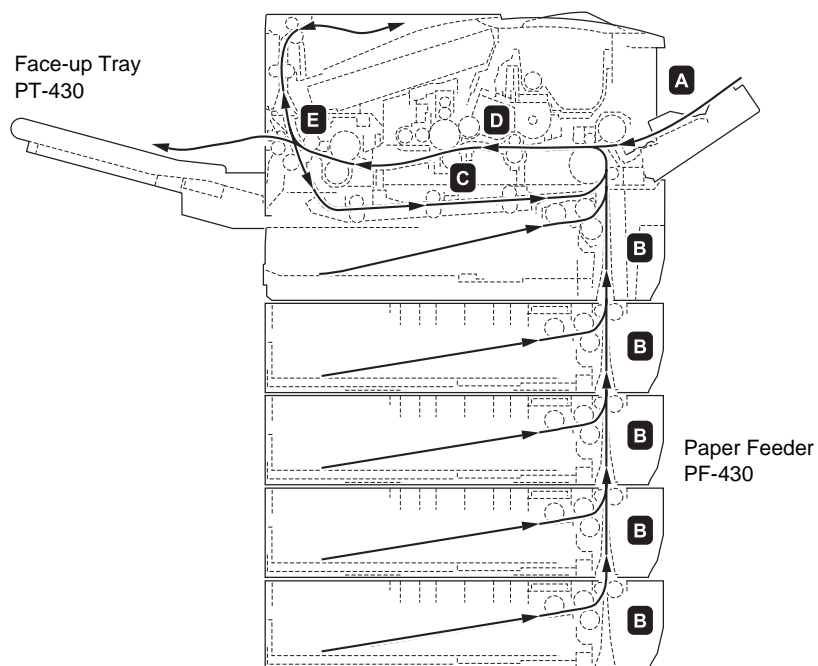

| Paper jam message              | Paper jam location | Description  | Reference page |
|--------------------------------|--------------------|--|----------------|
| Paper jam<br>MP Tray           | A                  | Paper is jammed at the MP tray.                          | page 4-12      |
| Paper jam<br>Cassette 1 (to 5) | B                  | Paper is jammed at the optional paper feeder's cassette. | page 4-13      |
| Paper jam<br>Duplexer          | C                  | Paper is jammed inside the duplex section.               | page 4-13      |

| Paper jam message   | Paper jam location | Description                           | Reference page |
|---------------------|--------------------|---------------------------------------|----------------|
| Paper jam Printer   | D                  | Paper is jammed inside the printer.   | page 4-14      |
| Paper jam Rear Unit | E                  | Paper is jammed inside the rear unit. | page 4-15      |

### General considerations for clearing jams

Bear in mind the following considerations when attempting jam removal:

**CAUTION:** When pulling the paper, pull it gently so as not to tear it. Torn pieces of paper are difficult to remove and may be easily overlooked, deterring the jam recovery.

- If paper jams occur frequently, try using a different type of paper, replace the paper with paper from another ream, flip the paper stack over, or rotate the paper stack 180 degrees. The printer may have problems if paper jams recur after the paper was replaced.
- Whether or not the jammed pages are reproduced normally after printing is resumed depends on the location of the paper jam.

### Utilizing Online Help Messages

Online help messages are available in the printer's message display to provide simple instructions for clearing jams. Press ( ? ) when the paper jam message has appeared. Then a help message will appear to facilitate jam clearing in the location.

### MP Tray

Paper is jammed at the MP tray. Remove the jammed paper using the procedure given below.

- 1 Remove the paper jammed at the MP tray.

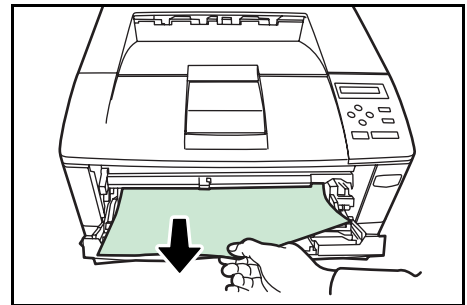

- 2 Open and close the top cover to clear the error.

## Paper Cassette

- 1 Pull out the paper cassette.
- 2 Remove any partially fed paper.  
Check to see if paper is loaded correctly. If not, reload the paper.

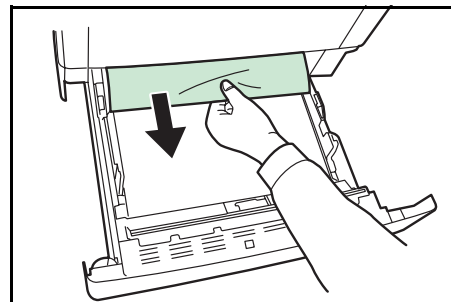

- 3 Push the paper cassette back in firmly. The printer warms up and resumes printing.

## Duplexer

Paper is jammed in the duplexer section. Remove the jammed paper using the procedure given below.



**CAUTION:** Do not touch parts in this area, because it may result in burn injury.

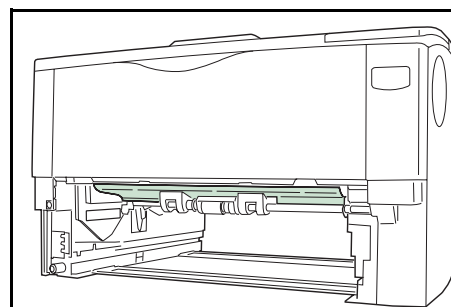

- 1 Pull the paper cassette all the way out of the printer.

- 2 Open the duplexer's cover and remove any jammed paper.

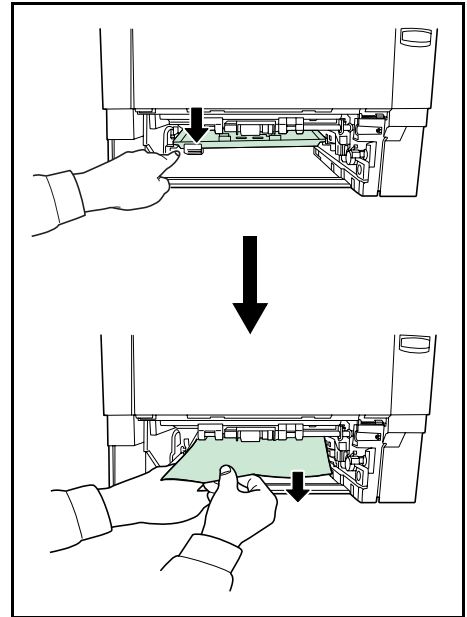

- 3 Insert the paper cassette into the slot in the printer. The printer warms up and resumes printing.

### The Inside of Printer

- 1 Open the top cover and MP tray. And lift the developer unit together with the toner container out of the printer.

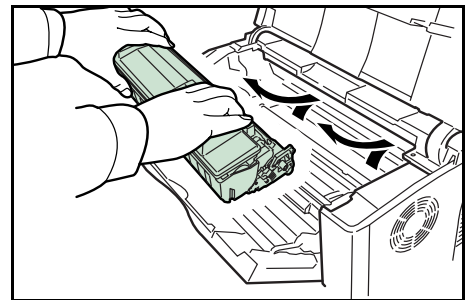

- 2 Open the feed cover.

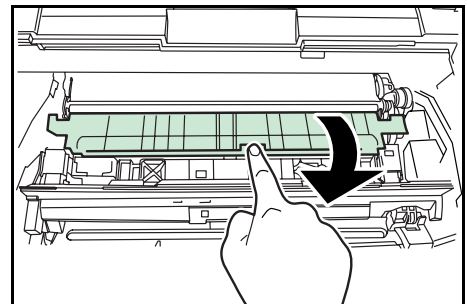

- 3** Remove the paper from the printer.

If the jammed paper appears to be pinched by rollers, pull it along the normal running direction of the paper.

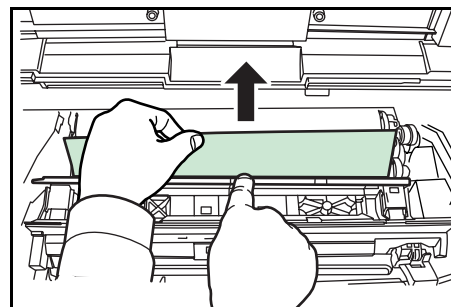

**NOTE:** If you cannot find a paper jam, try checking inside the rear of the printer. Refer to *Rear Unit* on page 4-15.

- 4** Insert the developer unit together with the toner container, back into the machine.

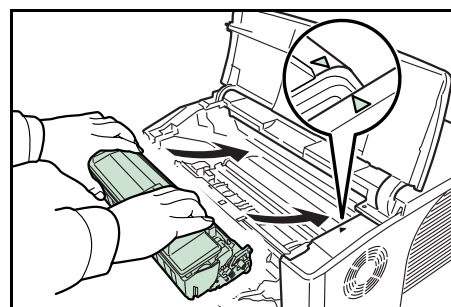

- 5** Close the top cover and MP tray. The printer warms up and resumes printing

## Rear Unit

- 1** If paper is not completely ejected into the output tray, open the rear unit.

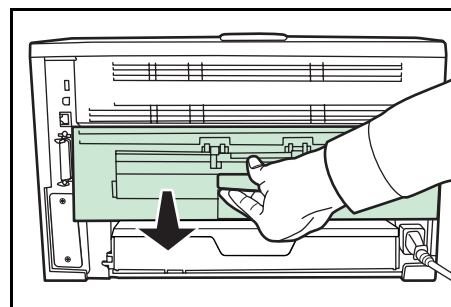

- 2** Open the fuser cover and remove the jammed paper by pulling it out.

**NOTE:** If you cannot find a paper jam, try checking inside the rear of the printer.

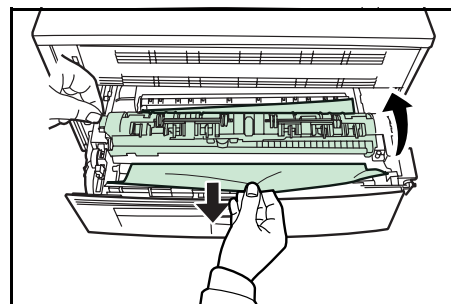

**CAUTION:** The fuser unit inside the printer is hot. Do not touch it with your hands as it may result in burn injury.

- 
- 
- 3** Close the rear unit in firmly. The printer warms up and resumes printing.

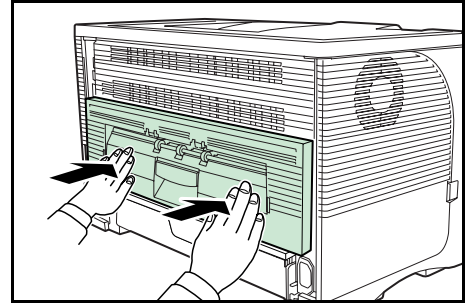

## Paper Feeder

Paper is jammed at optional paper cassette 2 (to 5). Refer to the Installation Guide for the optional paper feeder and remove the jammed paper.

# 5 Specifications

**NOTE:** Specifications are subject to change without notice.

| Item  | Description   |
|---|---|
| Printing Method   | Semiconductor laser and electrophotography  |
| Printing Speeds<br>- Simplex<br><br>- Duplex                      | A3: 16ppm<br>A4: 32ppm<br>A5: 32ppm<br><br>A3: 10ppm<br>A4: 23ppm   |
| Paper Sizes<br>- Cassette<br><br>- MP Tray                        | A3, A4, A5, B4, B5, Ledger, Letter, Legal, Envelope C4, Envelope C5, ISO B5, Executive, Oficio II, 8 kai, 16 kai, Folio, and Custom (148 x 210 to 297 x 432mm [5 13/16 x 8 1/4 to 11 11/16 x 17"])<br><br>A3, A4, A5, A6, B4, B5, B6, Ledger, Letter, Legal, Envelope Monarch, Envelope DL, Envelope C4, Envelope C5, ISO B5, Executive, Envelope # 6, Envelope # 9, Envelope # 10, Hagaki, Oufuku Hagaki, Oficio II, 8 kai, 16 kai, Statement, Folio, Yokei 2, Yokei 4, and Custom (70 x 148 to 297 x 450mm [2 3/4 x 5 13/16 to 11 11/16 x 18"]) |
| Paper Types<br>- Cassette<br><br>- MP Tray                        | Plain, Preprinted, Bond, Recycled, Rough, Letterhead, Color, Prepunched, High quality, and Custom<br><br>Plain, Transparency, Preprinted, Labels, Bond, Recycled, Vellum, Rough, Letterhead, Color, Prepunched, Envelope, Cardstock, Thick, High quality, and Custom  |
| Paper Feed Source Capacity<br>- Cassette<br><br>- MP Tray         | 250 sheets (80g/m <sup>2</sup> )<br><br>100 sheets (80g/m <sup>2</sup> )  |
| Output Tray Capacity<br>- Top Tray<br><br>- Face-up Tray (Option) | 250 sheets (80g/m <sup>2</sup> )<br><br>PT-430: 250 sheets (80g/m <sup>2</sup> )  |
| Warm-up Time (23°C, 50%RH)<br>- Power on<br><br>- Sleep           | 15 seconds or less<br><br>15 seconds or less  |

| Item  | Description   |
|---|---|
| First Print Out (A4, 22°C, 60%RH)   | 23 seconds or less (Ready)  |
| Resolution  | Fine 1200, Fast 1200, 600 dpi, 300 dpi  |
| Monthly Duty<br>- Average<br><br>- Maximum  | 5,000 pages<br><br>150,000 pages  |
| Operating Systems   | Microsoft Windows 95/98/Me/2000/XP<br>Microsoft Windows NT4.0<br>Microsoft Windows Server 2003<br>Apple Macintosh OS 9<br>Apple Macintosh OS X                                  |
| Controller  | PowerPC750Cxr 400MHz  |
| Memory<br>- Standard<br><br>- Maximum   | 64MB<br><br>576MB   |
| Interface<br>- Standard<br><br><br>- Option   | USB: Hi-Speed USB<br>Full-Speed USB (USB memory slot)<br>Parallel: IEEE1284<br>Network: 10BASE-T/100BASE-TX<br>KUIO-LV slot<br><br>IB-11: Serial<br>IB-21E: 10BASE-T/100BASE-TX |
| Operation Environment<br>- Temperature<br><br>- Relative Humidity<br><br>- Altitude<br><br>- Illumination | 10 to 32.5 °C<br><br>15 to 80%<br><br>2,500m maximum<br><br>1,500lux maximum  |
| Dimensions (W x D x H)  | 469 x 395 x 285mm (18 1/2 x 15 5/8 x 11 1/4")   |
| Weight (without toner container)  | 19.5kg (43lb)   |
| Operating noise (in accordance with ISO7779 [Bystander Position, sound pressure level at the front])      | During printing: LpA = 50dB (A)<br><br>During standby: LpA = 40dB (A)<br><br>During sleep mode: immeasurably low  |





**Headquarters:**

225 Sand Road,  
Fairfield, New Jersey 07004-0008  
TEL : (973) 808-8444  
FAX : (973) 882-6000

**New York Branch:**

1410 Broadway 23rd floor  
New York, NY 10018  
TEL : (917) 286-5400  
FAX : (917) 286-5402

**Northeastern Region:**

225 Sand Road,  
Fairfield, New Jersey 07004-0008  
TEL : (973) 808-8444  
FAX : (973) 882-4401

**Midwestern Region:**

201 Hansen Court Suite 119  
Wood Dale, Illinois 60191  
TEL : (630) 238-9982  
FAX : (630) 238-9487

**Western Region:**

14101 Alton Parkway,  
Irvine, California 92618-7006  
TEL : (949) 457-9000  
FAX : (949) 457-9119

**Southeastern Region:**

1500 Oakbrook Drive,  
Norcross, Georgia 30093  
TEL : (770) 729-9786  
FAX : (770) 729-9873

**Southwestern Region:**

2825 West Story Road,  
I

Hoeksteen 40, 2132 M  
The Netherlands  
Phone: +31.(0)20.654.  
Home page: <http://www>

Slotsmarken 11, B  
Denmark  
Phone: +45.7022.3880

Rua do Centro Cultural, no 41 1700-106 Lisbon,  
Portugal  
Phone: +351.(0)21.843.6780

527 Kyalami Boulevard,  
Kyalami Business Park Midrand,  
South Africa  
Phone: +27.(0)11.540.2600

Headquarters:  
225 Sand Road,  
Fairfield, New Jersey 07004-0008,  
U.S.A.  
Phone: (973) 808-8444

Level 3, 6-10 Talavera Road, North Ryde,  
N.S.W. 2113 Australia  
Phone: (02) 9888-9999

1-3 Parkhead Place, Albany  
P.O. Box 302 125 NHPC, Auckland,  
New Zealand  
Phone: (09) 415-4517

9/209 Ratchada-Prachachem Road,  
Bang Sue, Bangkok 10800, Thailand  
Phone: (02) 586-0320

121 Genting Lane, 3rd Level,  
Singapore 349572  
Phone: 67418733

11/F., Mita Centre,  
552-566, Castle Peak Road,  
Tsuen Wan, New Territories,  
Hong Kong  
Phone: 24297422

7F-1~2, No.41, Lane 221, Gangchi Rd.  
Neihu District, Taipei, Taiwan, 114. R.O.C.  
Phone: (02) 87511560

2-28, 1-chome, Tamatsukuri, Chuo-ku  
Osaka 540-8585, Japan  
Phone: (06) 6764-3555  
<http://www.kyoceramita.com>

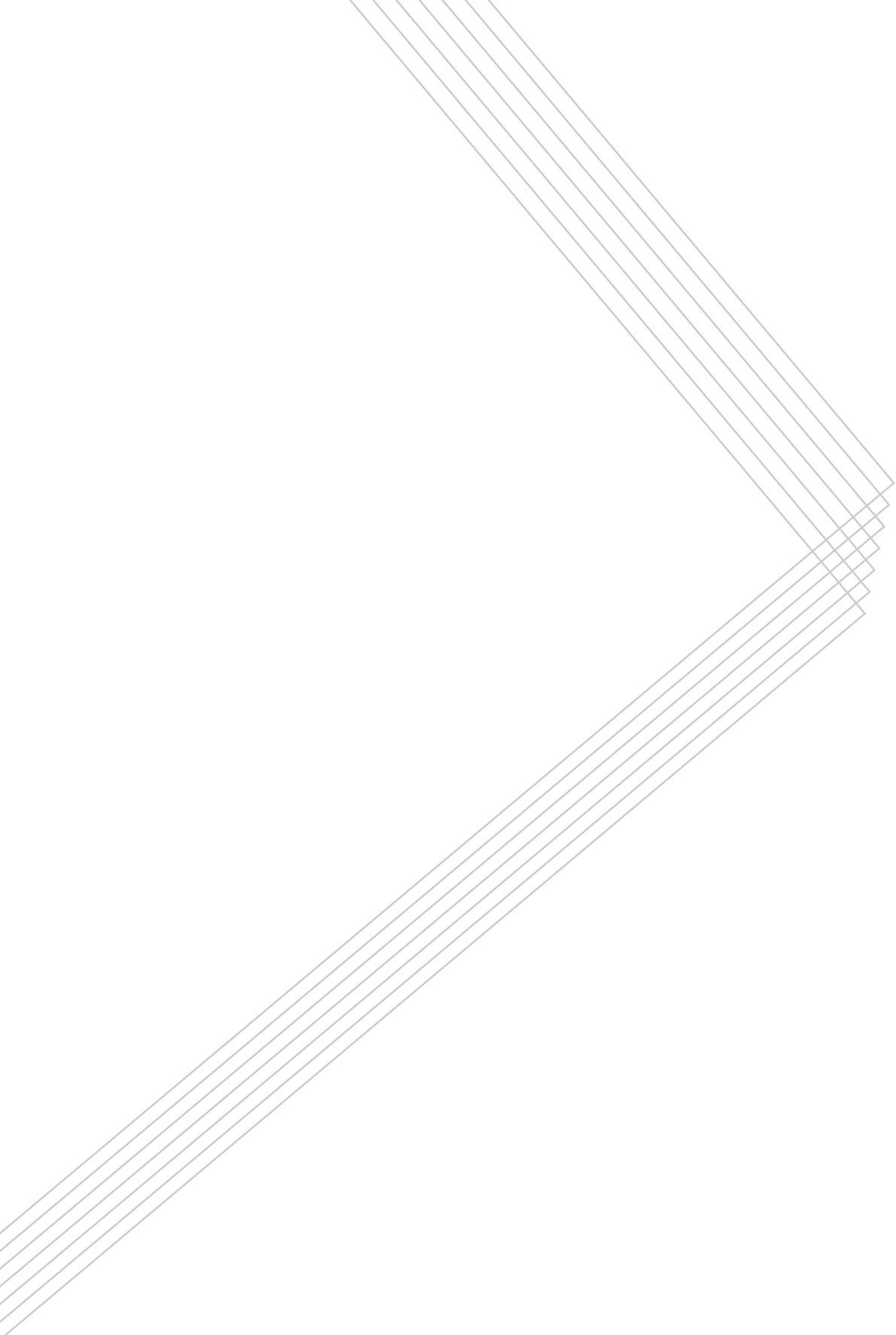

## Free Manuals Download Website

<http://myh66.com>

<http://usermanuals.us>

<http://www.somanuals.com>

<http://www.4manuals.cc>

<http://www.manual-lib.com>

<http://www.404manual.com>

<http://www.luxmanual.com>

<http://aubethermostatmanual.com>

Golf course search by state

<http://golfingnear.com>

Email search by domain

<http://emailbydomain.com>

Auto manuals search

<http://auto.somanuals.com>

TV manuals search

<http://tv.somanuals.com>