



FS-C5016N

Color Page Printer



Operation Guide

Please read the Operation Guide before using the printer. Keep it close to the printer for easy reference.

The sections of this guide and parts of the printer marked with symbols are safety warnings meant to protect the user, other individuals and surrounding objects, and ensure correct and safe usage of the printer. The symbols and their meanings are indicated below.

⚠ WARNING: Indicates that serious injury or even death may result from insufficient attention to or incorrect compliance with the related points.

⚠ CAUTION: Indicates that personal injury or mechanical damage may result from insufficient attention to or incorrect compliance with the related points.

Symbols

The \triangle symbol indicates that the related section includes safety warnings. Specific points of attention are indicated inside the symbol.

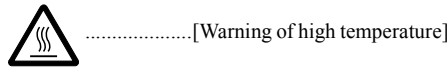
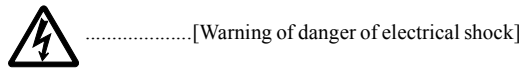
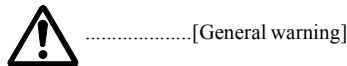

The \otimes symbol indicates that the related section includes information on prohibited actions. Specifics of the prohibited action are indicated inside the symbol.

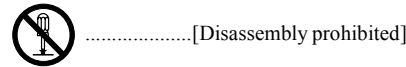
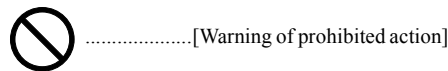

The \bullet symbol indicates that the related section includes information on actions which must be performed. Specifics of the required action are indicated inside the symbol.

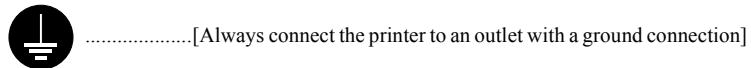
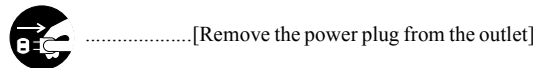
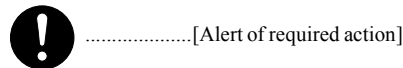

Please contact your service representative to order a replacement if the safety warnings in the guide are illegible or if the guide itself is missing. (fee required)

Caution

NO LIABILITY IS ASSUMED FOR ANY DAMAGE CAUSED BY IMPROPER INSTALLATION.

Notice on Software

SOFTWARE USED WITH THIS PRINTER MUST SUPPORT THE PRINTER'S EMULATION MODE. The printer is factory-set to emulate the PCL. The emulation mode can be changed by following the procedures described in [Chapter 3](#).

Notice

The information in this guide is subject to change without notification. Additional pages may be inserted in future editions. The user is asked to excuse any technical inaccuracies or typographical errors in the present edition.

No responsibility is assumed if accidents occur while the user is following the instructions in this guide. No responsibility is assumed for defects in the printer's firmware (contents of its read-only memory).

This guide, any copyrightable subject matter sold or provided with or in connection with the sale of the page printer, are protected by copyright. All rights are reserved. Copying or other reproduction of all or part of this guide, any copyrightable subject matter without the prior written consent of Kyocera Mita Corporation is prohibited. Any copies made of all or part of this guide, any copyrightable subject must contain the same copyright notice as the material from which the copying is done.

Regarding Tradenames

PRESCRIBE is a registered trademark of Kyocera Corporation. KPDL is trademark of Kyocera Corporation.

Diablo 630 is a product of Xerox Corporation. IBM Proprinter X24E is a product of International Business Machines Corporation. Epson LQ-850 is a product of Seiko Epson Corporation.

Hewlett-Packard, PCL, and PJI are registered trademarks of Hewlett-Packard Company. Centronics is a trade name of Centronics Data Computer Inc. PostScript is a registered trademark of Adobe Systems Incorporated. Macintosh is a registered trademark of Apple Computer, Inc. Microsoft, Windows, and Windows NT are registered trademarks of Microsoft Corporation. PowerPC and Microdrive are trademarks of International Business Machines Corporation. CompactFlash is a trademark of SanDisk Corporation. ENERGY STAR is a U.S. registered mark. All other brand and product names are registered trademarks or trademarks of their respective companies.

This Kyocera Mita page printer uses PeerlessPrintXL to provide the HP LaserJet compatible PCL 6 language emulation. PeerlessPrintXL is a trademark of The Peerless Group, Redondo Beach, CA 90278, U.S.A.

This product was developed using the Tornado™ Real Time Operating System and Tools from Wind River Systems.

AGFA  This product contains UFST™ and MicroType® from Agfa Monotype Corporation.



IBM PROGRAM LICENSE AGREEMENT

THE DEVICE YOU HAVE PURCHASED CONTAINS ONE OR MORE SOFTWARE PROGRAMS ("PROGRAMS") WHICH BELONG TO INTERNATIONAL BUSINESS MACHINES CORPORATION ("IBM"). THIS DOCUMENT DEFINES THE TERMS AND CONDITIONS UNDER WHICH THE SOFTWARE IS BEING LICENSED TO YOU BY IBM. IF YOU DO NOT AGREE WITH THE TERMS AND CONDITIONS OF THIS LICENSE, THEN WITHIN 14 DAYS AFTER YOUR ACQUISITION OF THE DEVICE YOU MAY RETURN THE DEVICE FOR A FULL REFUND. IF YOU DO NOT SO RETURN THE DEVICE WITHIN THE 14 DAYS, THEN YOU WILL BE ASSUMED TO HAVE AGREED TO THESE TERMS AND CONDITIONS.

The Programs are licensed not sold. IBM, or the applicable IBM country organization, grants you a license for the Programs only in the country where you acquired the Programs. You obtain no rights other than those granted you under this license.

The term "Programs" means the original and all whole or partial copies of it, including modified copies or portions merged into other programs. IBM retains title to the Programs. IBM owns, or has licensed from the owner, copyrights in the Programs.

1. License

Under this license, you may use the Programs only with the device on which they are installed and transfer possession of the Programs and the device to another party.

If you transfer the Programs, you must transfer a copy of this license and any other documentation to the other party. Your license is then terminated. The other party agrees to these terms and conditions by its first use of the Program.

You may not:

- 1) use, copy, modify, merge, or transfer copies of the Program except as provided in this license;
- 2) reverse assemble or reverse compile the Program; or
- 3) sublicense, rent, lease, or assign the Program.

2. Limited Warranty

The Programs are provided "AS IS."

THERE ARE NO OTHER WARRANTIES COVERING THE PROGRAMS (OR CONDITIONS), EXPRESS OR IMPLIED, INCLUDING, BUT NOT LIMITED TO, THE IMPLIED WARRANTIES OF MERCHANTABILITY AND FITNESS FOR A PARTICULAR PURPOSE.

Some jurisdictions do not allow the exclusion of implied warranties, so the above exclusion may not apply to you.

3. Limitation of Remedies

IBM's entire liability under this license is the following:

- 1) For any claim (including fundamental breach), in any form, related in any way to this license, IBM's liability will be for actual damages only and will be limited to the greater of:
 - a) the equivalent of U.S. \$25,000 in your local currency; or
 - b) IBM's then generally available license fee for the Program

This limitation will not apply to claims for bodily injury or damages to real or tangible personal property for which IBM is legally liable.

IBM will not be liable for any lost profits, lost savings, or any incidental damages or other economic consequential damages, even if IBM, or its authorized supplier, has been advised of the possibility of such damages. IBM will not be liable for any damages claimed by you based on any third party claim. This limitation of remedies also applies to any developer of Programs supplied to IBM. IBM's and the developer's limitations of remedies are not cumulative. Such developer is an intended beneficiary of this Section. Some jurisdictions do not allow these limitations or exclusions, so they may not apply to you.

4. General

You may terminate your license at any time. IBM may terminate your license if you fail to comply with the terms and conditions of this license. In either event, you must destroy all your copies of the Program. You are responsible for payment of any taxes, including personal property taxes, resulting from this license. Neither party may bring an action, regardless of form, more than two years after the cause of action arose. If you acquired the Program in the United States, this license is governed by the laws of the State of New York. If you acquired the Program in Canada, this license is governed by the laws of the Province of Ontario. Otherwise, this license is governed by the laws of the country in which you acquired the Program.

Typeface Trademark Acknowledgement

All resident fonts in this printer are licensed from Agfa Corporation.

Helvetica, Palatino and Times are registered trademarks of Linotype-Hell AG. ITC Avant Garde Gothic, ITC Bookman, ITC ZapfChancery and ITC Zapf Dingbats are registered trademarks of International Typeface Corporation.

Agfa Monotype License Agreement

- 1) "Software" shall mean the digitally encoded, machine readable, scalable outline data as encoded in a special format as well as the UFST Software.
- 2) You agree to accept a non-exclusive license to use the Software to reproduce and display weights, styles and versions of letters, numerals, characters and symbols ("Typefaces") solely for your own customary business or personal purposes at the address stated on the registration card you return to Agfa Japan. Under the terms of this License Agreement, you have the right to use the Fonts on up to three printers. If you need to have access to the fonts on more than three printers, you need to acquire a multi-user license agreement which can be obtained from Agfa Japan. Agfa Japan retains all rights, title and interest to the Software and Typefaces and no rights are granted to you other than a License to use the Software on the terms expressly set forth in this Agreement.
- 3) To protect proprietary rights of Agfa Japan, you agree to maintain the Software and other proprietary information concerning the Typefaces in strict confidence and to establish reasonable procedures regulating access to and use of the Software and Typefaces.
- 4) You agree not to duplicate or copy the Software or Typefaces, except that you may make one backup copy. You agree that any such copy shall contain the same proprietary notices as those appearing on the original.
- 5) This License shall continue until the last use of the Software and Typefaces, unless sooner terminated. This License may be terminated by Agfa Japan if you fail to comply with the terms of this License and such failure is not remedied within thirty (30) days after notice from Agfa Japan. When this License expires or is terminated, you shall either return to Agfa Japan or destroy all copies of the Software and Typefaces and documentation as requested.
- 6) You agree that you will not modify, alter, disassemble, decrypt, reverse engineer or decompile the Software.
- 7) Agfa Japan warrants that for ninety (90) days after delivery, the Software will perform in accordance with Agfa Japan-published specifications, and the diskette will be free from defects in material and workmanship. Agfa Japan does not warrant that the Software is free from all bugs, errors and omissions.

THE PARTIES AGREE THAT ALL OTHER WARRANTIES, EXPRESSED OR IMPLIED, INCLUDING WARRANTIES OF FITNESS FOR A PARTICULAR PURPOSE AND MERCHANTABILITY, ARE EXCLUDED.
- 8) Your exclusive remedy and the sole liability of Agfa Japan in connection with the Software and Typefaces is repair or replacement of defective parts, upon their return to Agfa Japan.

IN NO EVENT WILL AGFA JAPAN BE LIABLE FOR LOST PROFITS, LOST DATA, OR ANY OTHER INCIDENTAL OR CONSEQUENTIAL DAMAGES, OR ANY DAMAGES CAUSED BY ABUSE OR MISAPPLICATION OF THE SOFTWARE AND TYPEFACES.
- 9) New York, U.S.A. law governs this Agreement.
- 10) You shall not sublicense, sell, lease, or otherwise transfer the Software and/or Typefaces without the prior written consent of Agfa Japan.
- 11) Use, duplication or disclosure by the Government is subject to restrictions as set forth in the Rights in Technical Data and Computer Software clause at FAR 252-227-7013, subdivision (b)(3)(ii) or subparagraph (c)(1)(ii), as appropriate. Further use, duplication or disclosure is subject to restrictions applicable to restricted rights software as set forth in FAR 52.227-19 (c)(2).
- 12) YOU ACKNOWLEDGE THAT YOU HAVE READ THIS AGREEMENT, UNDERSTAND IT, AND AGREE TO BE BOUND BY ITS TERMS AND CONDITIONS. NEITHER PARTY SHALL BE BOUND BY ANY STATEMENT OR REPRESENTATION NOT CONTAINED IN THIS AGREEMENT. NO CHANGE IN THIS AGREEMENT IS EFFECTIVE UNLESS WRITTEN AND SIGNED BY PROPERLY AUTHORIZED REPRESENTATIVES OF EACH PARTY. BY OPENING THIS DISKETTE PACKAGE, YOU AGREE TO ACCEPT THE TERMS AND CONDITIONS OF THIS AGREEMENT.

FCC statement (for users in the United States)

This device complies with Part 15 of the FCC Rules. Operation is subject to the following two conditions: (1) This device may not cause harmful interference, and (2) this device must accept any interference received, including interference that may cause undesired operation.

Note:

This equipment has been tested and found to comply with the limits for a Class B digital device, pursuant to Part 15 of the FCC Rules. These limits are designed to provide reasonable protection against harmful interference in a residential installation. This equipment generates, uses, and can radiate radio frequency energy and, if not installed and used in accordance with the instructions, may cause harmful interference to radio communications. However, there is not guarantee that interference will not occur in a particular installation. If this equipment does not cause harmful interference to radio or television reception, which can be determined by turning the equipment off and on, the user is encouraged to try to correct the interference by one or more of the following measures:

- Reorient or relocate the receiving antenna.
- Increase the distance between the equipment and the receiver.
- Connect the equipment into an outlet on a circuit different from that used for the receiver.
- Consult the dealer or an experienced radio/TV technician for help.

Changes or modifications not expressly approved by the manufacturer for compliance could void the user's authority to operate the equipment. Shielded circular cables should be used for interfacing with the computer.

Cautions to the user:

- Any modifications without prior permission of Kyocera may cause harmful interference.
- If any modifications or changes are made to this equipment without prior permission of Kyocera, Kyocera as the manufacturer does not guarantee the compliance with the FCC Rules.
- The use of equipment that does not comply with the FCC Rules is prohibited.

Important Notes for Interface connectors

Be sure to power off the printer before connecting or disconnecting an interface cable. For protection against static electricity discharge to the printer's internal electronics through the interface connector(s), cover any interface connector that is not in use with the protective cap supplied.

Use shielded interface cables.

Cautionary Labels

The printer bears any of the following labels.

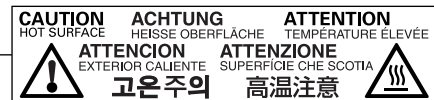
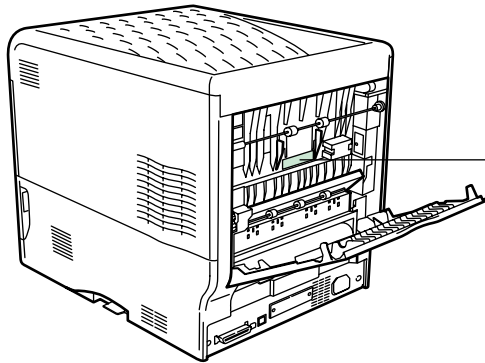

For Europe, Asia,
and other countries

For U.S.A. and
Canada

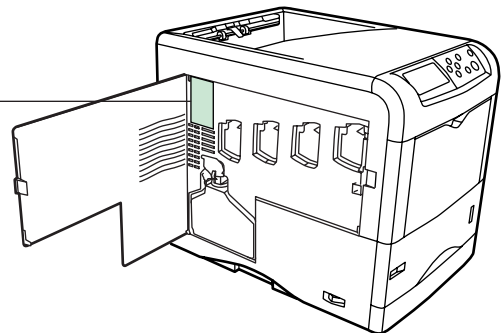

Ozone concentration

The printers generate ozone gas (O₃) which may concentrate in the place of installation and cause an unpleasant smell. To minimize the concentration of ozone gas to less than 0.1 ppm, we recommend you not to install the printer in a confined area where ventilation is blocked.

Declaration of Conformity for U.S.A.

Model name: Color Page Printer FS-C5016N
Trade name: Kyocera Mita
Responsible party: Kyocera Mita America, Inc.
Address: 225 Sand Road PO Box 40008 Fairfield, New Jersey 07004-0008, U.S.A.
Telephone: (973) 808-8444
Fax: (973) 882-6000

Manufacturer: Kyocera Mita Corporation Tamaki Plant
Manufacturer's address: 704-19, Nojino, Tamaki-cho, Watarai-gun, Mie-ken 519-0497, Japan

This device complies with Part 15 of the FCC Rules. Operation is subject to the following two conditions: (1) this device may not cause harmful interference, and (2) this device must accept any interference received, including interference that may cause undesired operation.

The manufacturer and its merchandising companies retain the following technical documentation in anticipation of the inspection that may be conducted by the authorities concerned.

User's instruction that conforms to the applicable specifications.

Technical drawings.

Descriptions of the procedures that guarantee the conformity.

Other technical information.

Kyocera Mita America Inc.

CE Marking Directive

According to Council Directive 89/336/EEC and 73/23/EEC

Manufacturer: Kyocera Mita Corporation Tamaki Plant
Manufacturer's address: 704-19, Nojino, Tamaki-cho, Watarai-gun, Mie-ken 519-0497, Japan

Declares that the product

Product name: Color Page Printer

Model number: FS-C5016N

(as tested with enhancement optional units; Duplex unit DU-300, Paper Feeder PF-60)

Conforms to the following product specifications:

EN 55 022: 1998 Class B

EN 61 000-3-2: 1995

EN 61 000-3-3: 1995

EN 55 024: 1998

EN 60 950: 2000

The manufacturer and its merchandising companies retain the following technical documentation in anticipation of the inspection that may be conducted by the authorities concerned.

User's instruction that conforms to the applicable specifications.

Technical drawings.

Descriptions of procedures that guarantee conformity.

Other technical information.

Declaration of Conformity for Australia

Manufacturer: Kyocera Mita Corporation Tamaki Plant
Manufacturer's address: 704-19, Nojino, Tamaki-cho, Watarai-gun, Mie-ken 519-0497, Japan
declares that the product

Product name: Color Page Printer
Model name: FS-C5016N

Description of devices: This Page Printer Model FS-C5016N is the 16 ppm (monochrome/color), A4 size and utilized plane paper; dry toner; etc. The printer can be equipped with several enhancement optional units as a paper feeder as PF-60, a duplex unit as DU-300.

conforms to the following product specifications:

AS/NZS 3548: 1995 (EN 55 022: 1998 Class B)
IEC60950 (EN 60 950): 1999

The manufacturer and its merchandising companies retain the following technical documentation in anticipation of the inspection that may be conducted by the authorities concerned.

User's instruction that conforms to the applicable specifications
Technical drawings
Descriptions of procedures that guarantee conformity
Other technical information

The manufacturer has been employed with ISO9001 scheme. JQA and BS have attested the manufacturer.

Kyocera Mita Australia Pty., Ltd.
6-10 Talavera Road, North Ryde, NSW 2113, Australia
Telephone: +61 2-9888-9999
Fax: +61 2-9888-9588

Canadian Department of Communications compliance statement

This Class B digital apparatus complies with Canadian ICES-003.

Avis de conformité aux normes du ministère des Communications du Canada

Cet appareil numérique de la classe B est conforme à la norme NMB-003 du Canada.

ISO 7779

Maschinenlärminformationsverordnung 3. GSGV, 18.01.1991: Der höchste Schalldruckpegel beträgt 70 dB (A) oder weniger gemäß ISO 7779.

Disclaimer

Kyocera Mita will not be liable to customers or any other person or entity for any loss or damage caused or alleged to be caused directly or indirectly by equipment sold or furnished by us, including but not limited to, any interruption of service, loss of business or anticipatory profits, or consequential damages resulting from the use or operation of the equipment or software.

ENERGY STAR®



As an ENERGY STAR Partner, we have determined that this product meets the ENERGY STAR guidelines for energy efficiency.

The basic objective of the ENERGY STAR Program is to reduce environmental pollution by encouraging the manufacture and sale of equipment that uses energy more efficiently.

This printer is equipped with a sleep timer function that conforms with the standards of the ENERGY STAR Program. This function makes it possible to reduce the amount of electrical power consumed by the printer. For maximum power savings, turn off the printer's power supply when not using the printer for extended periods of time.

For details on the sleep timer function and printer power consumption, refer to this manual.

Initial settings of the sleep timer function and power saved using the sleep timer function:

Initial sleep mode setting	Power consumption in sleep mode
15 minutes (60 minutes)	21 W (45 W) [for U.S.A. and Canada] 24 W (45 W) [for Europe, Asia, and other countries]

(): ENERGY STAR program guideline

Group for Energy Efficient Appliances (GEEA)



The goal of GEEA is efficient use of energy. This product has a high-efficiency profile and meets the criteria for receiving the GEEA-Label.





Initial sleep mode setting	Power Consumption	
	Power off	Sleep mode
15 min. (60 min.)	0 W (1 W)	24 W (30 W)

(): GEEA criteria

Installation Precautions

Environment

CAUTION

- Avoid placing the printer on or in locations which are unstable or not level. Such locations may cause the printer to fall down or fall over. This type of situation presents a danger of personal injury or damage to the printer. 
- Avoid locations with humidity or dust and dirt. If dust or dirt becomes attached to the power plug, clean the plug to avoid the danger of fire or electrical shock. 
- Avoid locations near radiators, heaters, or other heat sources, or locations near flammable items, to avoid the danger of fire. 
- To keep the printer cool and facilitate changing of parts and maintenance, allow access space as shown below. Leave adequate space, especially around the side cover, to allow air to be properly ventilated out of the printer. 

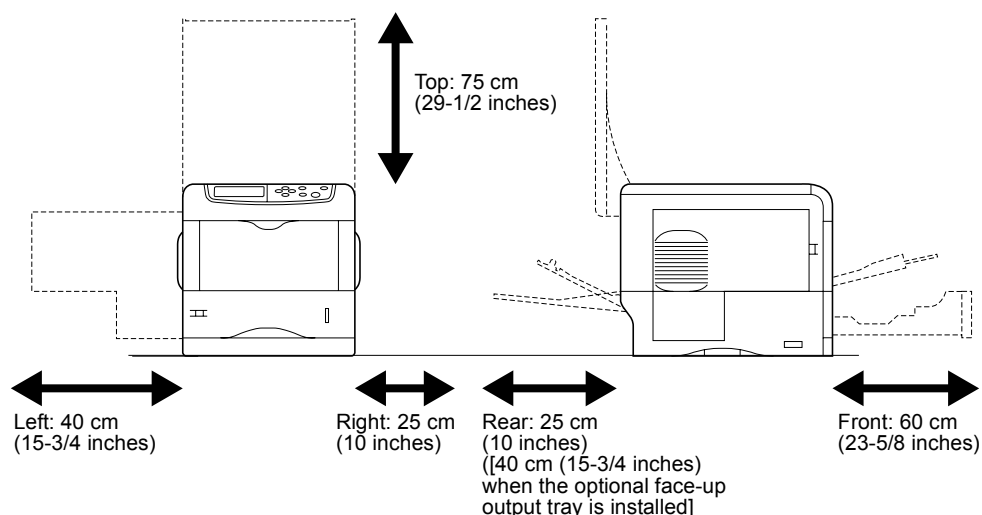



Other Precautions

- Adverse environmental conditions may affect the safe operation and performance of the printer. Install in an air-conditioned room (recommended room temperature: around 20 °C, humidity: around 65 % RH) and avoid the following locations when selecting a site for the printer.
 - Avoid locations near a window or with exposure to direct sunlight.
 - Avoid locations with vibrations.
 - Avoid locations with drastic temperature fluctuations.
 - Avoid locations with direct exposure to hot or cold air.
 - Avoid poorly ventilated locations.
- If the floor is delicate against casters, when this product is moved after installation, the floor material may be damaged.

Power Supply/Grounding the Printer

WARNING

- DO NOT use a power supply with a voltage other than that specified. Avoid multiple connections in the same outlet. These types of situations present a danger of fire or electrical shock... 
- Plug the power cord securely into the outlet. If metallic objects come in contact with the prongs on the plug, it may cause a fire or electric shock. 
- Always connect the printer to an outlet with a ground connection to avoid the danger of fire or electrical shock in case of an electric short. If an earth connection is not possible, contact your service representative. 

Other Precautions

- Connect the power plug to the closest outlet possible to the printer.

Handling of Plastic Bags









WARNING

- Keep the plastic bags that are used with the printer away from children. The plastic may cling to their nose and mouth causing suffocation. 





Precautions for Use

Cautions when Using the Printer

WARNING

- DO NOT place metallic objects or containers with water (flower vases, flower pots, cups, etc.) on or near the printer. This type of situation presents a danger of fire or electrical shock should they fall inside. 
- DO NOT remove any of the covers from the printer as there is a danger of electrical shock from high voltage parts inside the printer. 
- DO NOT damage, break or attempt to repair the power cord. DO NOT place heavy objects on the cord, pull it, bend it unnecessarily or cause any other type of damage. These types of situations present a danger of fire or electrical shock. 
- NEVER attempt to repair or disassemble the printer or its parts as there is a danger of fire, electrical shock or damage to the laser. If the laser beam escapes, there is a danger of it causing blindness. 
- If the printer becomes excessively hot, smoke appears from the printer, there is an odd smell, or any other abnormal situation occurs, there is a danger of fire or electrical shock. Turn the power switch OFF (O) immediately, remove the power plug from the outlet and contact your service representative. 
- If anything harmful (paper clips, water, other fluids, etc.) falls into the printer, turn the power switch OFF (O) immediately. Next, remove the power plug from the outlet to avoid the danger of fire or electrical shock. Then contact your service representative. 
- DO NOT remove or connect the power plug with wet hands, as there is a danger of electrical shock. 
- ALWAYS contact your service representative for maintenance or repair of internal parts. 

CAUTION

- DO NOT pull the power cord when removing it from the outlet. If the power cord is pulled, the wires may become broken and there is a danger of fire or electrical shock. (ALWAYS grasp the power plug when removing the power cord from the outlet.) 
- ALWAYS remove the power plug from the outlet when moving the printer. If the power cord is damaged, there is a danger of fire or electrical shock. 
- If the printer will not be used for a short period of time (overnight, etc.), turn the power switch OFF (O). If it will not be used for an extended period of time (vacations, etc.), remove the power plug from the outlet for safety purposes during the time the printer is not in use. 
- For safety purposes. ALWAYS remove the power plug from the outlet when performing cleaning operations. 
- If dust accumulates within the printer, there is a danger of fire or other trouble. It is therefore recommended that you consult with your service representative in regard to cleaning of internal parts. This is particularly effective if accomplished prior to seasons of high humidity. Consult with your service representative in regard to the cost of cleaning the internal parts of the printer. 

Other Precautions

- DO NOT place heavy objects on the printer or cause other damage to the printer.
- DO NOT open the top cover, turn off the main switch, or pull out the power plug during printing.
- During printing, some ozone is released, but the amount does not cause any ill effect to one's health. If, however, the printer is used over a long period of time in a poorly ventilated room or when printing an extremely large number of copies, the smell may become unpleasant. To maintain the appropriate environment for print work, it is suggested that the room be properly ventilated.
- DO NOT touch electrical parts, such as connectors or printed circuit boards. They could be damaged by static electricity.
- DO NOT attempt to perform any operations not explained in this handbook.
- CAUTION: Use of controls or adjustments or performance of procedures other than those specified herein may result in hazardous radiation exposure.
- If the printer will not be used for an extended period of time, remove the paper from the cassette, return it to its original package and reseal it.

Cautions for Toner Handling

⚠ CAUTION

- Do not incinerate toner and toner containers. Dangerous sparks may cause burn.
- Never open the toner container.
- Make sure not to inhale the toner, and not to rub your eyes or touch your mouth with the hands stained with the toner. And make sure not to stick to your skin.
- For the disposal of old toner container, consult your dealer. Or dispose of the toner or toner containers in accordance with Federal, State and Local rules and regulations.
- Keep away the toner container.



For More Information...

Item	Description
Installation Guide (paper manual)	Describes the printer setup procedure.
Quick Reference Guide (paper manual)	Describes common information about the printer such as loading paper, understanding messages, etc.
The following documents are stored in the CD-ROM as PDF documents.	
Operation Guide (this manual)	Guides you through topics concerning the operations and maintenance of the printer.
KX Printer Drivers Operation Guide	Describes how to install and set the printer driver.
PRESCRIBE Command Technical Reference	PRESCRIBE is the native language of the Kyocera Mita printers. This Technical Reference contains the information about how the printing is performed using the PRESCRIBE commands as well as the font and emulation description. Also included is a list of permanent parameters and their explanation needed when customizing your printer.
PRESCRIBE Command Reference	Gives a detailed explanation of the PRESCRIBE command syntax and parameters with the aid of print examples.

Guide to the Operation Guide

This Operation Guide has the following chapters:

Chapter 1 Introduction

This chapter explains printer features and the names of parts.

Chapter 2 Handling Paper

This chapter explains the types of paper that can be used with the printer.

Chapter 3 Using the Operator Panel

This chapter explains the message display, indicators and keys on the operator panel, and how to make various settings from the operator panel.

Chapter 4 Troubleshooting

This chapter explains how to handle printer problems that may occur, such as paper jams.

Chapter 5 Maintenance

This chapter explains how to replace the toner container and how to care for your printer.

Appendix A Options

This appendix introduces the available options to be used with the printer.

Appendix B Computer Interface

This appendix explains the pin assignment and specifications for the printer's parallel interface, USB interface, and serial interface.

Appendix C Technical Specifications

This appendix lists the printer's specifications.

Contents

Chapter 1 Introduction

1.1	Features	1-2
1.1.1	General	1-2
1.1.2	Hardware	1-2
1.1.3	Software	1-3
1.1.4	Networking	1-4
1.2	Parts and Functions	1-5
1.2.1	Front	1-5
1.2.2	Left	1-6
1.2.3	Internal	1-7
1.2.4	Rear	1-8

Chapter 2 Handling Paper

2.1	General	2-2
2.1.1	Available paper types	2-2
2.1.2	Paper specifications	2-2
2.1.3	Minimum and Maximum Paper Sizes	2-3
2.1.4	Recommended Paper	2-3
2.2	Selecting the Right Paper	2-4
2.2.1	Guidelines	2-4
2.2.2	Paper properties	2-5
2.2.3	Other properties of paper	2-7
2.3	Loading Paper	2-8
2.3.1	Loading Paper into the Cassette	2-8
2.3.2	Loading Paper into the MP (Multi-Purpose) Tray	2-14
2.4	Special Paper	2-16
2.4.1	Selecting the Special Paper	2-16
2.5	Paper Type	2-21

Chapter 3 Using the Operator Panel

3.1	Understanding the Operator Panel	3-2
3.1.1	Message Display	3-2
3.1.2	Indicators in Message Display	3-3
3.1.3	Keys	3-6
3.2	Using the Menu Selection System	3-8
3.2.1	Menu Selection System	3-8
3.2.2	Menu System Road Map	3-10
3.3	Menu Map and Status Pages	3-15
3.3.1	Printing a Menu Map	3-15
3.3.2	Printing a Status Page	3-17
3.4	e-MPS	3-20
3.4.1	Using Quick Copy	3-21
3.4.2	Using Proof-and-Hold	3-23
3.4.3	Printing a Private Print/Stored Job	3-24
3.4.4	Retrieving Jobs from Virtual Mailbox (VMB)	3-28
3.4.5	Changing e-MPS Configuration	3-30
3.5	Changing the Interface Parameters	3-34
3.5.1	Changing Parallel Interface Mode	3-34
3.5.2	Changing Serial Interface Parameters	3-35
3.5.3	Changing Network Interface Parameters	3-37
3.5.4	Resolving IP Address	3-39
3.6	Making Default Settings	3-42

3.6.1	Default Emulation	3-42
3.6.2	Alternative Emulation for KPDLEmulation	3-43
3.6.3	Printing KPDLErrors	3-44
3.6.4	Default Font	3-45
3.7	Pagination	3-52
3.7.1	Number of Copies	3-52
3.7.2	Print Orientation	3-53
3.7.3	Page Protect Mode	3-54
3.7.4	Linefeed (LF) Action	3-55
3.7.5	Carriage-Return (CR) Action	3-56
3.7.6	Wide A4 Pitch	3-57
3.8	Setting Print Quality	3-58
3.8.1	Gloss Mode	3-58
3.9	Operating the Storage Device	3-59
3.9.1	Using the Memory Card	3-59
3.9.2	Using the Optional Hard Disk	3-66
3.9.3	Using the RAM Disk	3-66
3.10	Paper Handling	3-68
3.10.1	MP Tray Mode	3-68
3.10.2	Setting MP Tray Paper Size	3-69
3.10.3	Setting the MP Tray Paper Type	3-71
3.10.4	Setting the Cassette Paper Size	3-72
3.10.5	Setting the Cassette Paper Type	3-76
3.10.6	Selecting the Paper Feed Source	3-77
3.10.7	Duplex Printing	3-78
3.10.8	Overriding Difference between A4 and Letter	3-80
3.10.9	Creating Custom Paper Type	3-81
3.10.10	Resetting the Custom Paper Type	3-84
3.10.11	Selecting the Output Stack	3-85
3.11	Selecting Monochrome or Color Printing	3-86
3.12	Reading Life Counters	3-87
3.12.1	Displaying the Total Printed Pages	3-87
3.12.2	Resetting the Toner Counter	3-88
3.13	Other Modes	3-89
3.13.1	Selecting the Message Language	3-89
3.13.2	Automatic Form Feed Timeout Setting	3-90
3.13.3	Setting the Sleep Timer	3-91
3.13.4	Received Data Dump	3-93
3.13.5	Printer Resetting	3-94
3.13.6	Resource Protection	3-95
3.13.7	Alarm (Buzzer) Setting	3-96
3.13.8	Auto Continue Setting	3-97
3.13.9	Setting the Auto Continue Recovery Time	3-98
3.13.10	Duplex Printing Error Detection Setting	3-99
3.13.11	Color Registration	3-100
3.13.12	Printing the Service Status Page	3-103
3.13.13	Color Calibration	3-104

Chapter 4 Troubleshooting

4.1	General Guidelines	4-2
4.1.1	Tips	4-2
4.2	Print Quality Problems	4-3
4.3	Error Messages	4-7
4.4	Clearing Paper Jams	4-12
4.4.1	Possible Paper Jam Locations	4-12
4.4.2	General considerations for clearing jams	4-13
4.4.3	Jam at the Paper Cassette	4-14

4.4.4	Jam at the Paper Transfer Unit	4-15
4.4.5	Jam at the Rear Cover	4-16
4.4.6	Jam at the MP Tray	4-17
4.4.7	Jam at the Optional Envelope Feeder	4-17
4.4.8	Jam at the Optional Duplexer	4-17

Chapter 5 Maintenance

5.1	Toner Container Replacement	5-2
5.1.1	Frequency of toner container replacement	5-2
5.1.2	Understanding Messages Requesting Toner Container Replacement	5-3
5.1.3	Replacing the Toner Container	5-4
5.2	Replacing the Waste Toner Box	5-8
5.3	Cleaning the Printer	5-11
5.3.1	Cleaning the Main Charger Unit	5-11
5.3.2	Cleaning the Paper Transfer Unit	5-16
5.3.3	Cleaning the Advanced Beam Array Lenses	5-17

Appendix A Options

A.1	Options	A-2
A.2	Expansion Memory Modules	A-3
A.2.1	Installing the Memory Modules	A-4
A.3	General Description of Options	A-7
A.3.1	Memory Card	A-7
A.3.2	PF-60 Paper Feeder	A-8
A.3.3	DU-300 Duplex Unit	A-8
A.3.4	PT-300 Face-up Output Tray	A-9
A.3.5	Hard Disk	A-10
A.3.6	IB-20/IB-21E/IB-22 Network Interface Cards	A-11

Appendix B Computer Interface

B.1	Parallel Interface	B-2
B.1.1	Communication Modes	B-2
B.1.2	Interface Signals	B-3
B.2	USB Interface	B-5
B.2.1	Specifications	B-5
B.2.2	Interface Signals	B-5
B.3	Serial Interface (Option)	B-6
B.3.1	Interface Signals	B-6
B.3.2	Interface voltage levels	B-6
B.4	RS-232C Protocol	B-7
B.4.1	Parameters of the RS-232C Protocol	B-7
B.4.2	PRESCRIBE FRPO D0 Command	B-8
B.5	RS-232C Cable Connection	B-9
B.5.1	Preparing an RS-232C Cable	B-9
B.5.2	Connecting the Printer to the Computer	B-9

Appendix C Technical Specifications

C.1	Printer Specification	C-2
C.2	Printing Speeds	C-4

Index

Chapter 1 Introduction

Welcome to the professional color printer from Kyocera Mita. With the Ecosys Color FS-C5016N, you can print out color or monochrome pages at a speed of 16 pages per minute (A4 size) or 17 pages per minute (Letter and A5 sizes).

1.1 Features

This section outlines the common major printer features of the FS-C5016N Ecosys color page printer.

1.1.1 General

Components with an ultra-long product life

The main printer components such as the Advanced Beam Array, imaging drum, development units, and fuser unit have an ultra-long product life.

USB (Universal Serial Bus) Interface

This printer supports Full-Speed USB 2.0. Connection to a computer with a USB interface gives a higher communication speed than parallel interface connection.

High-speed printing

This printer supports print speeds of up to 16 pages per minute (A4 size) for both color and monochrome printouts. (Actual time varies according to page complexity.)

Superb color printing quality

This printer prints the gray level of 4 bpp (bits per pixel).

Intelligent color calibration system

The intelligent color calibration system automatically optimizes colors every time the printer is powered.

Variety of paper sizes and types

In addition to ordinary paper, you can use print media such as transparencies, labels, and other special papers for printouts.

Sleep mode

Conserves energy while printing is in standby.

1.1.2 Hardware

Advanced Performance Data Processing

A 400 MHz CPU, 96 MB of RAM, and the optional hard disk deliver ideal throughput for wide varying printing applications.

Expansion slot for hardware interfaces

This printer is equipped with an expansion slot for plugging in an optional network interface card or a hard disk.

Standard bidirectional parallel interface

Ensures high-speed data transfer between the host computer and printer.

Memory card slot

You can select and read the data in a memory card set in this slot from the printer operator panel.

Large-capacity paper cassette

The paper cassette can hold approximately 500 sheets of 80 g/m² paper which is 0.1 mm thick. The printer also has a multipurpose tray that can hold approximately 100 sheets of nonstandard size paper. Printed sheets can be stacked in the face-down output tray or an optional face-up output tray.

Displaying printer messages in any of eight languages

Printer messages can be displayed in English, French, German, Italian, Dutch, Spanish, or Portuguese.

1.1.3 Software

e-MPS

'e-MPS' is an abbreviation for 'enhanced-Multiple Printing System,' which is a post-processing function that combines electronic sorting, job retention, and virtual mailboxing.

When printing multiple copies of a document, the data is transferred from the computer to the printer only for the first copy; the data is then stored on the printer's hard disk. Copies of the document are printed using the stored data.

Printing is performed faster with less computer spooling time and less network traffic.

Furthermore, printed data that is stored on the hard disk can be called up using job retention functions, such as Quick Copy etc., allowing you to quickly print additional copies of a document from the printer at any time, without needing to re-spool the document or start up the computer system.

Printer control language PRESCRIBE

The printer uses PRESCRIBE, Kyocera Mita's page printer control language with enhanced color graphics capabilities. The simple commands of PRESCRIBE allow the programmers to easily define pagination and device control.

KPDL3 (Kyocera Printer Description Language 3)

The printer uses KPDL3, Kyocera's implementation of the PostScript page description language Level 3. The printer has 136 fonts that are compatible with Adobe PostScript fonts. (The printer also has 80 PCL fonts.)

PDF417 two-dimensional bar codes

The printer has the built-in two-dimensional stacked bar codes of PDF 417 (Portable Data File 417).

Account Management System

This printer comes equipped with an Account Management System function which records the number of pages printed by each department. The administrator can preset the maximum number of pages that each department will be allowed to print.

1.1.4 Networking

Built-in and external network interfaces

Because the network interface supports TCP/IP, IPX/SPX, NetBEUI and EtherTalk protocols, network printing is possible with various environments including Windows, Macintosh, UNIX and NetWare, etc.

Support for network printer monitor utility (KM-NET VIEWER)

Allows network wide management of printers. See the readme file in the CD-ROM (supplied with the printer) for details.

1.2 Parts and Functions

This section provides explanations and illustrations for you to determine the parts and their functions. Try to be familiar with the names and functions of these parts for correct use and optimal performance.

1.2.1 Front

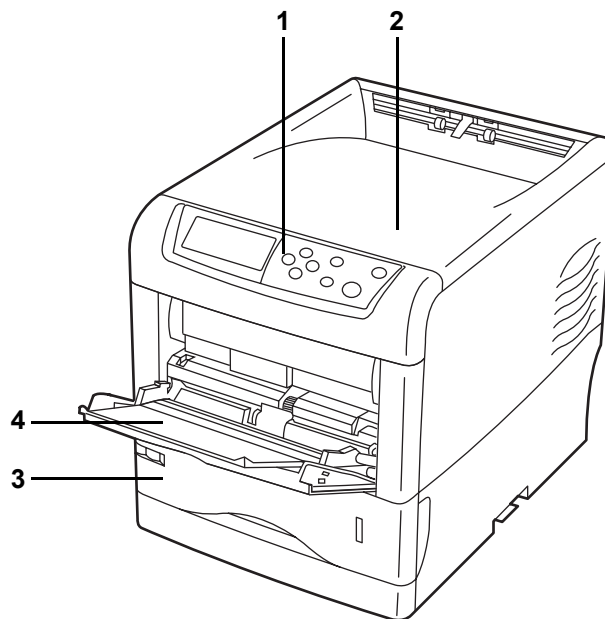

Figure 1-1

- 1 Operator Panel**
Used to specify printer functions and display the printer operating status.
- 2 Top Cover**
When open, this cover gives you access to the internal component for replacing toner containers.
- 3 Paper Cassette**
The cassette holds up to 500 sheets of A5 to Legal sizes (80 g/m²).
- 4 MP (Multi-Purpose) Tray**
The MP tray holds up to 100 sheets of paper (80 g/m²). Transparencies, envelopes, etc. must be fed using this tray.

1.2.2 Left

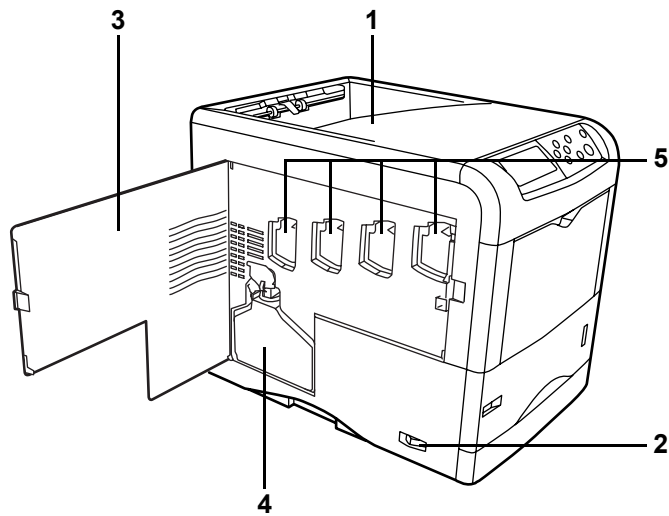

Figure 1-2

- 1 Face-down Tray**
This tray receives printouts face down.
- 2 Power Switch**
This switch turns printer power on and off.
- 3 Left Cover**
This cover needs to be opened when replacing the waste toner box or cleaning the main charger units.
- 4 Waste Toner Box**
This plastic box collects waste toner for later disposal. The box has a cap which is used to seal the box opening when being disposed of.
- 5 Main Charger Units**
The main charger units are electrical components included in each toner container and are used to transfer toner onto the drum unit. Whenever you replace a toner container, be sure to clean the corresponding main charger unit.

1.2.3 Internal

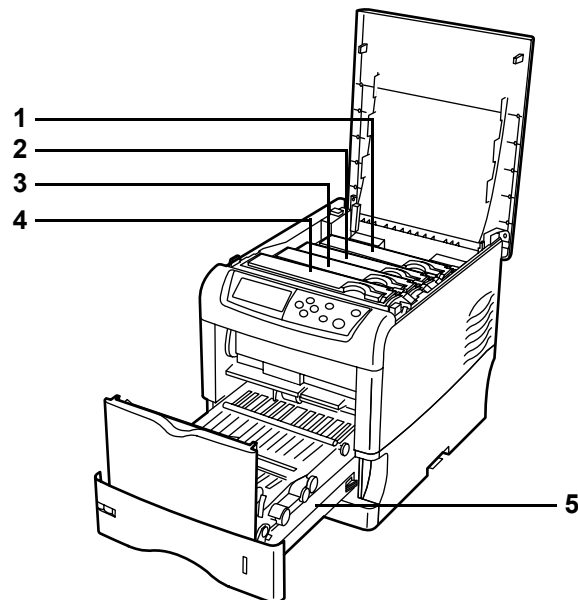

Figure 1-3

1 Magenta Toner Container

This container holds magenta (M) toner. You must replace the container when the toner run out.

2 Cyan Toner Container

This container holds cyan (C) toner. You must replace the container when the toner run out.

3 Yellow Toner Container

This container holds yellow (Y) toner. You must replace the container when the toner run out.

4 Black Toner Container

This container holds black (K) toner. You must replace the container when the toner run out.

5 Paper Transfer Unit

The paper transfer unit feeds paper from the cassette for printing.

1.2.4 Rear

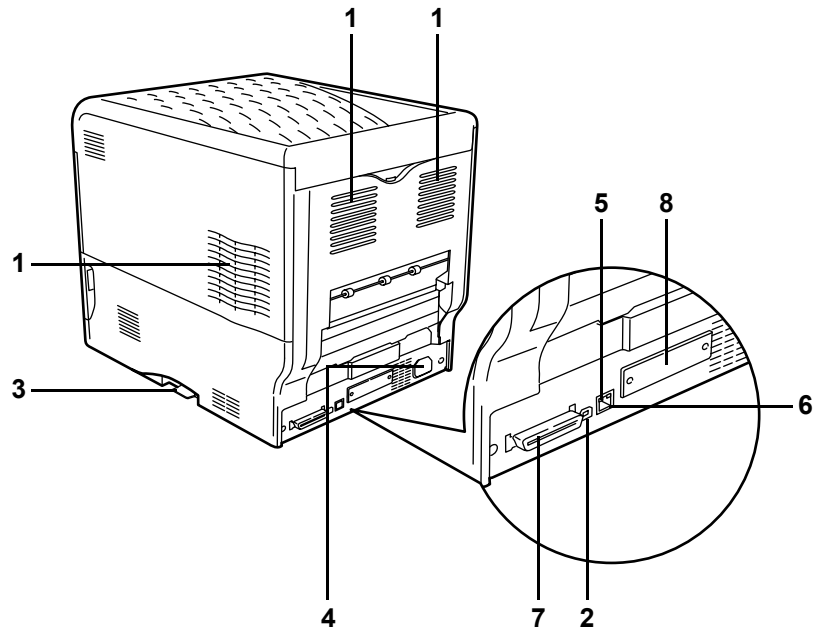

Figure 1-4

1 Vents

Air is purged through these vents to cool down the inside.

2 USB Interface Connector

This connector is a USB interface that conforms to the Full-Speed USB 2.0. Use a USB cable between this connector and the USB port on a computer.

3 Memory Card Slot

This slot receives a memory card. A memory card can hold fonts, macros, forms, etc., that can be downloaded in the printer's memory. For details, see [Appendix A Options, section A.3.1 Memory Card on page A-7](#).

4 Power Cord Connector

This connector accepts the power cord supplied with the printer.

5 Network indicators

These indicators light according to the communication status with the network.

Right: 10BASE-T/100BASE-TX indicator

Lights when you are connected to the network at 10 Mbps or 100 Mbps.

Left: Status indicator

Flashes during data communication.

6 Network Interface Connector

Connects to the network via a 10BASE-T/100BASE-TX network cable.

7 Parallel Interface Connector

This connector is for a standard Centronics parallel interface cable from the computer. Connect this connector to the computer's parallel port.

8 Option Interface Slot (Network/Serial)

This slot can be used to hold the optional network interface card, a hard disk or the serial interface board kit. For details, see [Appendix A Options](#).

Chapter 2 Handling Paper

The printer can use a variety of media in various sizes. However, any media you will choose to use with the printer must be in accordance with the guidelines and specifications in this chapter. Use of paper not satisfying these guidelines and specifications may cause problems such as frequent paper jams, poor quality printing, and possible damage to the printer mechanism.

Even meeting the instructions provided in this chapter, special media such as transparencies, labels, envelopes, non-standard-size paper must be fed directly from the printer's MP (multi-purpose) tray and delivered in the face-up tray in 'straight path' manner. For details on use of MP tray, see [Chapter 3 Using the Operator Panel, section 3.10.1 MP Tray Mode on page 3-68](#).

2.1 General

The Ecosys Color FS-C5016N printer is designed for high-grade bond (copy) paper, like those widely used for ordinary xerographic copiers. The printer will also support other types of paper as long as they meet the standards explained in this chapter.

Selecting the right paper is very important. Use of unsuitable paper can cause paper jams, misfeed, curling, poor print quality, and even worse, printer damage. This chapter shows you how to use your printer in a way that will ensure efficient, error-free printing and minimal printer damage. This practice will increase your office productivity.



Note

Kyocera Mita will not be liable for any problems that may occur if you use paper that does not meet these standards.

2.1.1 Available paper types

The FS-C5016N printer can use almost any type of printer paper. This printer accepts paper used for xerographic copiers as well.

Paper comes in three generic grades: economy, standard, and premium. The grades are determined by how easily the paper can pass through the printer. This depends on the smoothness, size, moisture content, and cutting of the paper. The higher the grade, the less risk of problems (such as paper jams), and higher the print quality.

The differences in paper characteristics of different paper makers also affect the printer performance. High-performance printer can produce high-quality results only when the right types of paper are selected. Low-priced paper is not always economical, especially if it ends up causing frequent printing problems.

Paper of the different grades is available in basis weights (explained later). The recommended basis weights of paper for the printer are 16, 20, and 28 pounds. When expressed in grams per square meter, the recommended basis weights range from 60 to 105 g/m².

2.1.2 Paper specifications

Table 2-1 summarizes the basic paper specifications. Details are given on the subsequent pages.

Item	Values
Weight (basis weight)	Cassette: 60 to 105 g/m ² (16 to 28 lb/ream) MP tray: 60 to 200 g/m ² (16 to 53 lb/ream)
Thickness	0.086 to 0.110 mm (3.4 to 4.3 mils)
Dimensions	See <i>Table 2-3</i> .
Dimensional accuracy	±0.7 mm (±0.0276 inches)
Squareness of corners	90 ±0.2 °
Moisture content	4 to 6 %

Table 2-1

Item	Values
Direction of grain	Long grain
Pulp content	80 % or more

Table 2-1 (Continued)

2.1.3 Minimum and Maximum Paper Sizes

The minimum and maximum paper sizes are as follows. For non standard paper such as cut-sheet, the MP (multi-purpose) tray must be used.

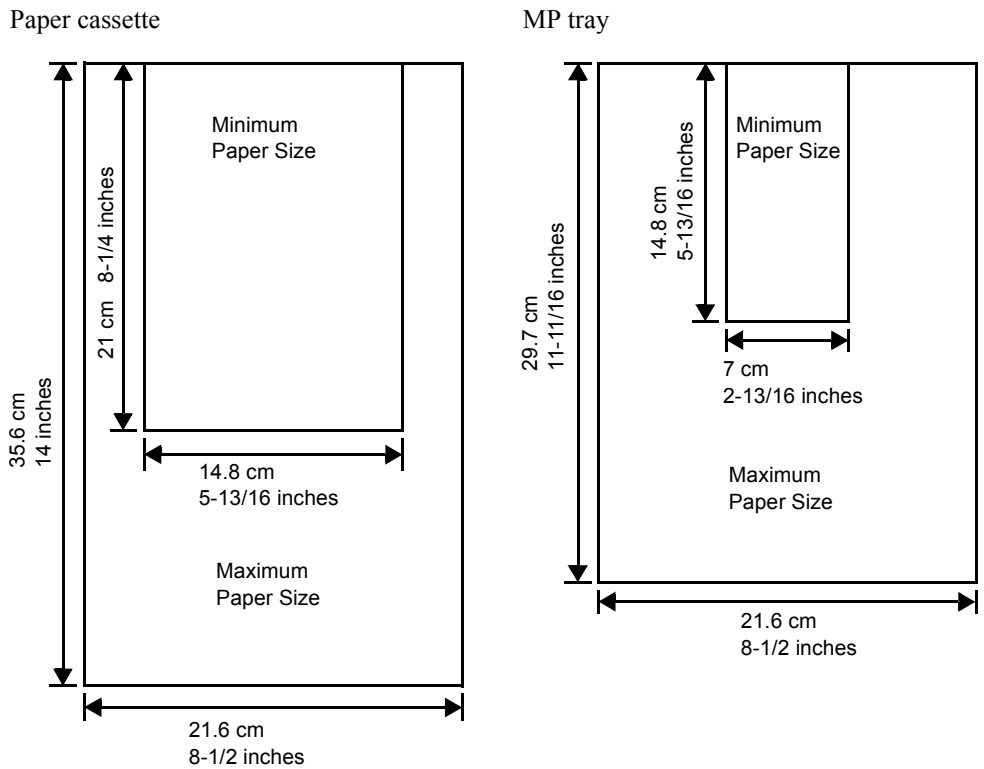

Figure 2-1

2.1.4 Recommended Paper

The following products are recommended for use with the printer for optimum performance.

Size	Product	Weight
Letter, Legal	Hammermill LASER PRINT	90 g/m ² (24 lb)
A4	NEUSIEDLER COLOR COPY	90 g/m ²

Table 2-2

2.2 Selecting the Right Paper

Printer printing is a process involving light, electrostatic discharge, toner, and heat. In addition, as the paper passes through the printer it undergoes considerable sliding, bending, and twisting motions. A high-quality printing paper matching the printer's requirements with-stands all these stresses, enabling the printer to turn out clean, crisp printed copy consistently.

This section describes the major considerations for selecting the right printing paper.

2.2.1 Guidelines

Paper conditions

Do not use paper with folded edges, curls, warps, smudges, tears, or embossing. Also do not use paper containing lint, clay, or paper debris. Using such paper may cause illegible printing, misfeeds, paper jams, etc., and shorten the product life of the printer. Never use paper with surface coating or other surface treatment. The paper surface should be as smooth and even as possible.

Paper composition

Do not use paper with surface-coating or containing plastic or carbon. The heat of fusing causes such paper to emit toxic fumes.

Bond paper should have at least an 80 % pulp content. The percentage of cotton and other fibers should not exceed 20 %.

Paper sizes

Table 2-3 lists the standard paper sizes and dimensions. Note that certain paper sizes are available only for MP tray feeding (as remarked) and face-up tray delivering. For details on using MP tray, see [Chapter 3 Using the Operator Panel, section 3.10.1 MP Tray Mode on page 3-68](#).

The dimensional tolerances for these paper sizes are ± 0.7 mm (± 0.0276 inches) for both length and width of paper. The corner angles must be $90 \pm 0.2^\circ$.

MP tray	Size	Cassette or MP tray	Size
Monarch	3-7/8 × 7-1/2 inches	Legal†	8-1/2 × 14 inches
Business	4-1/8 × 9-1/2 inches	Letter	8-1/2 × 11 inches
ISO A6	10.5 × 14.8 cm	ISO A4	21 × 29.7 cm
ISO DL	11 × 22 cm	ISO A5	14.8 × 21 cm
Commercial 9	3-7/8 × 8-7/8 inches	ISO C5	16.2 × 22.9 cm
Commercial 6-3/4	3-5/8 × 6-1/2 inches	ISO B5	17.6 × 25 cm
JIS B6	12.8 × 18.2 cm	JIS B5	18.2 × 25.7 cm
Statement	5-1/2 × 8-1/2 inches	Executive	7-1/4 × 10-1/2 inches

Table 2-3

MP tray	Size	Cassette or MP tray	Size
Hagaki	10 × 14.8 cm	Oficio II	8-1/2 × 13 inches
Ofuku-Hagaki	14.8 × 20 cm	Folio	21 × 33 cm
Youkei 2	11.4 × 16.2 cm	16 kai	19.7 cm × 27.3 cm
Youkei 4	10.5 × 23.5 cm		
Custom	Cassette: 14.8 to 21.6 cm × 21 to 35.6 cm (5-13/16 to 8-1/2 inches × 8-1/4 to 14 inches) MP tray: 7 to 21.6 cm × 14.8 to 29.7 cm (2-13/16 to 8-1/2 inches × 5-13/16 to 11-11/16 inches)		

Table 2-3 (Continued)

† Only with the paper cassette feeding

2.2.2 Paper properties

Smoothness

Paper should have a smooth, uncoated surface. Paper with a rough or sandy surface can cause gaps in printouts. However, paper with surfaces that are too smooth may cause multiple-sheet feeding and fogging problems (fogging is a gray background effect).

Basis weights

Basis weight is the weight in pounds of 500 sheets (called a ream) of paper cut to the basic size, which is 17 × 22 inches. The number of sheets in a ream and the basic paper size relating to basis weights depend on paper classifications. In the metric system, the basis weight is expressed in grams per square meter (g/m²).

Paper that is too heavy or too light may cause misfeeds, jams, and premature wear of printer parts. Uneven weight of paper can cause multiple-sheet feeding, print defects, poor toner fusing, blurring, and other print quality problems. The recommended basis weights for this printer are between 60 and 105 g/m² (16 to 28 lb per ream).

Paper Weight Equivalence Table

The paper weight is listed with expression in U.S. bond weight (lb) and European metric (g/m²). The shaded part indicates the standard weight.

U. S. Bond Weight (lb)	Europe Metric Weight (g/m ²)
16	60
17	64
20	75
21	80
22	81
24	90
27	100

Table 2-4

U. S. Bond Weight (lb)	Europe Metric Weight (g/m²)
28	105
32	120
34	128
36	135
39	148
42	157
43	163
47	176
53	199

Table 2-4 (Continued)**Thickness (Caliper)**

Thick paper is called high-caliper paper and thin paper is called low-caliper paper. Paper used by the printer should be neither too thick nor too thin. If you encounter paper jam, multiple-sheet feed, or too light printing problems, the paper may be too thin. If you encounter paper jam or too heavy printing problems, the paper may be too thick. The recommended thickness of a sheet for this printer is between 0.086 and 0.110 mm (from 3.4 to 4.3 mils).

Moisture content

Moisture content is the percentage of the weight of water in paper. Moisture affects the appearance, feeding, curling, electrostatic properties, toner fusing of the paper.

The moisture content of paper varies with the relative humidity in the room. If the room is too humid, paper will absorb more moisture. The edges will swell and the paper will become wavy. If the room is too dry and the paper loses moisture, the edges shrink and tighten, and the print contrast may be degraded.

Wavy or tight edges can cause paper misfeeds and misalignments. The recommended moisture content is between 4 and 6 %.

To maintain the correct moisture content level, store the paper in an environment that allows moisture control. These are tips for moisture control:

- Store paper in a cool, dry place.
- Leave packages of paper wrapped as long as possible. Rewrap unused paper.
- Return paper to its paper carton, whenever possible. Place the cartons on a pallet or other furniture so that they are not in direct contact with the floor.
- Before using paper stored for an extended period of time, condition it in the printer's environment for at least 48 hours.
- Do not expose paper to heat, direct sunlight, or damp.

Grain

Technically, grain is the direction of paper in the paper machine. Grain is parallel with the direction of movement in the paper machine. Grain long means that the grain runs along the length of the sheet, and grain short means that the grain runs along the width of the sheet. Because grain short causes paper feed problems, always select grain long for the printer.

2.2.3 Other properties of paper

Porosity

The density of paper structure, which indicates the compactness of the fiber bonding. It is also the characteristic that allows air to pass through paper (i.e., air permeability).

Stiffness

The ability of paper to resist deformation under stress. In the printer, limp paper can buckle and too stiff paper can bind. Both conditions result in paper jams.

Curl

Most paper naturally tends to curl one way. To produce flat printouts, load the paper sheets so that the upward pressure from the printer can correct their curling. When loading paper, it is also important to distinguish between the front side and backside of the paper. Be sure to follow the paper loading instructions printed on the paper carton.

Electrostatic discharge

During the printing process, paper is given an electrostatic charge to attract the toner. Therefore, the paper must discharge the static electricity so that the printouts do not stick to each other in the output tray.

Whiteness

The contrast of printed images depends on the whiteness of the paper. Whiter paper produces sharper and clearer images.

Quality control

Uneven paper sizes, corners that are not square, jagged paper edges, irregularly cut sheets, torn edges and corners, etc. can cause various printer troubles. Before purchasing paper, find out whether the paper store always takes measures to prevent such problems in its products.

Packaging

Paper sheets should be shipped in strong cartons to protect them from damage during transportation. Before purchasing paper, make sure the store ships its products in proper packages.

2.3 Loading Paper

The following explains the procedure for loading paper in the cassette and the MP tray.



Fan the media (paper/transparencies), then tap it on a level surface to avoid media jams or skewed printing.

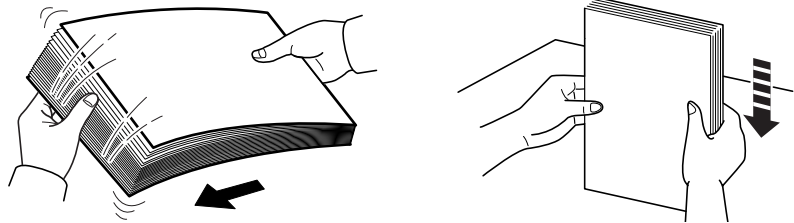

Figure 2-2

2.3.1 Loading Paper into the Cassette

Perform the following procedure to load paper into the cassette.

- 1** Pull the paper cassette all the way out of the printer.

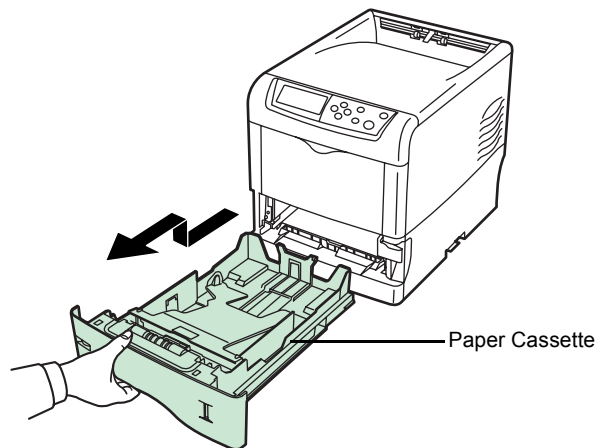

Figure 2-3

2 Push the bottom plate down until it locks.

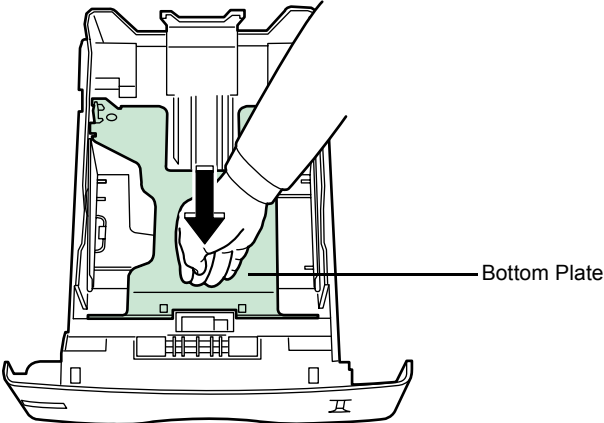

Figure 2-4

Standard paper sizes are attached to the inside of the paper cassette as shown in the following figure.

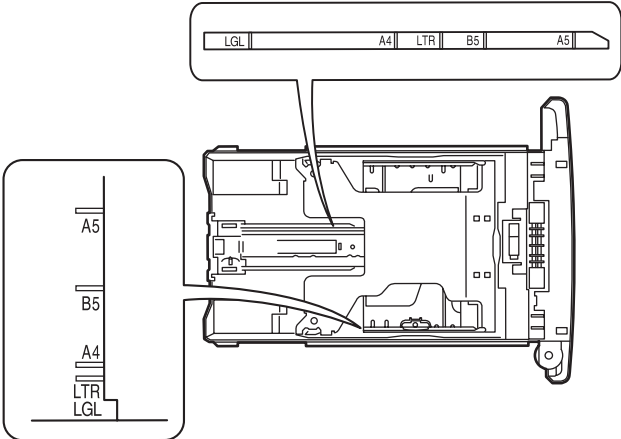

Figure 2-5

- 3 Turn the paper size dial so that the size of the paper you are going to use appears in the paper size window.

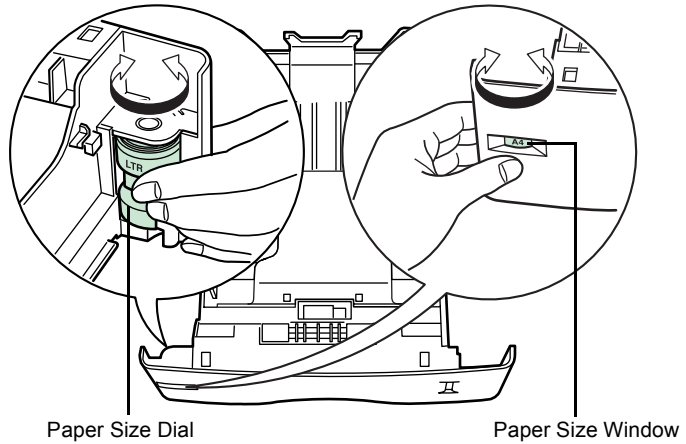

Figure 2-6



When the paper size dial is set to OTHER the paper size must be set into the printer on the operator panel. See [Chapter 3 Using the Operator Panel, section 3.10.4 Setting the Cassette Paper Size on page 3-72](#).

- 4 Adjust the position of the paper guides located on the left and right sides of the paper cassette. Pull the release lever on the left side guide and slide to the desired paper size.

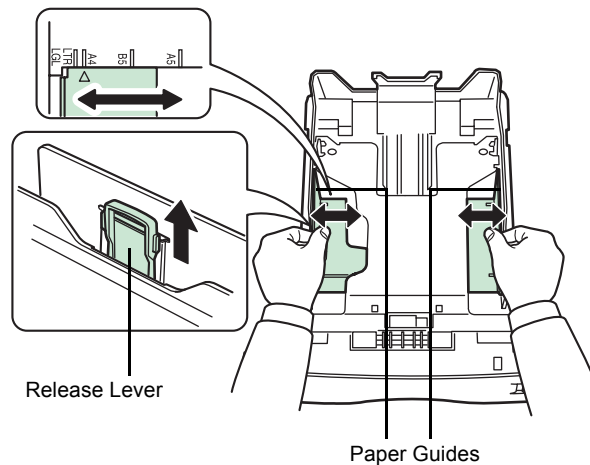

Figure 2-7

- 5** Adjust the position of the paper stopper located at the rear of the paper cassette. Pull the release lever and slide the paper stopper to the desired paper size. When shipped from the factory, the paper cassette is set to A4 size.

When using non-standard size paper, move the paper guides and paper stopper all the way out, insert the paper, then adjust the paper guides and paper stopper to the size of the paper. Adjust them so that they are in light contact with the paper.

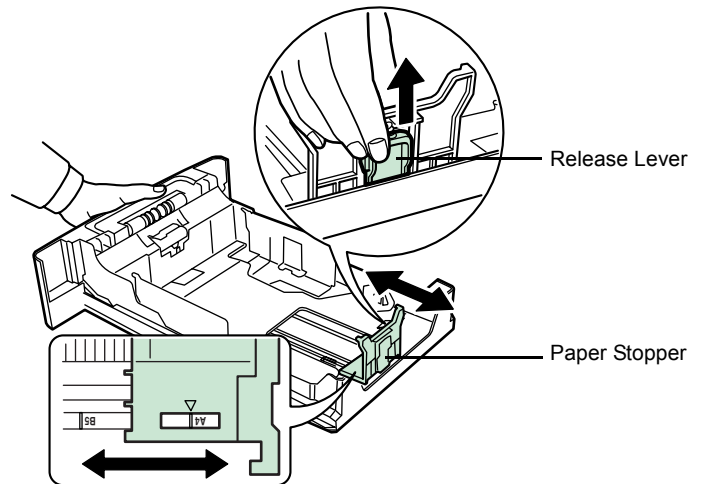

Figure 2-8

- 6** Slide the paper into the paper cassette.

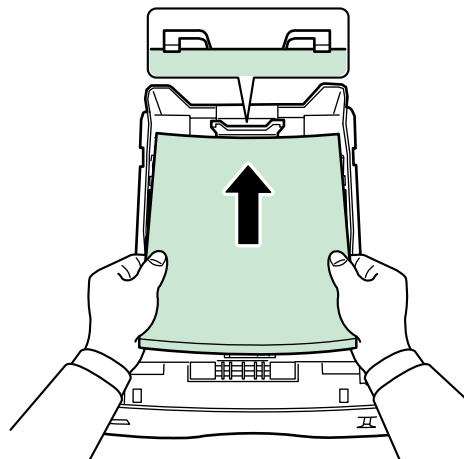

Figure 2-9



Note

- Do not load more paper than will fit under the load limits on the paper guides.
- The paper cassette will hold approximately 500 sheets of paper with a 80 g/m² (21 lb.) basis weight, or with a thickness of 0.11 mm.

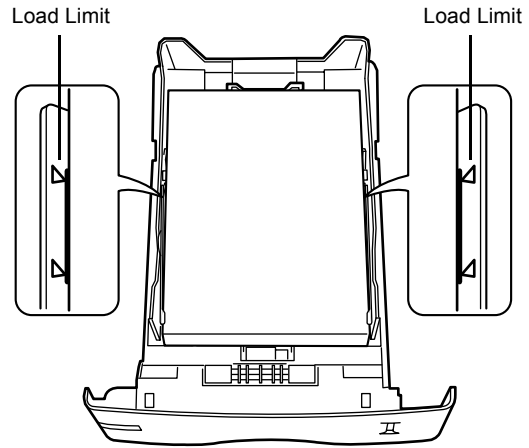

Figure 2-10

- 7** Set the stack of paper so that it is under the clips as shown.

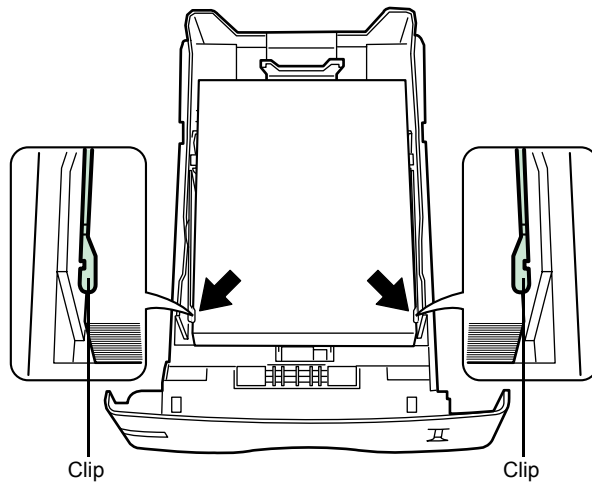

Figure 2-11

- 8 Insert the paper cassette into the slot in the printer. Push it straight in as far as it will go.

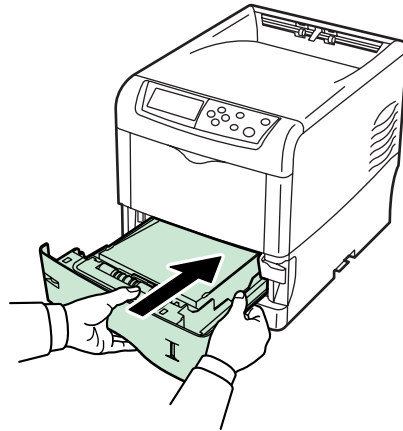



Figure 2-12

There is a paper gauge on the right side of the front of the paper cassette to indicate the remaining paper supply. When paper is exhausted, the pointer will go down to the level of  (empty).

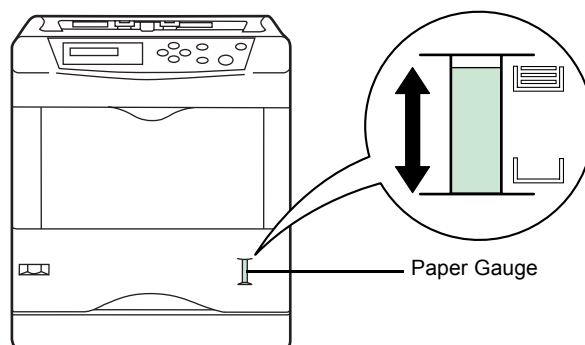

Figure 2-13

2.3.2 Loading Paper into the MP (Multi-Purpose) Tray

Perform the following procedure to load paper into the MP tray.

- 1** Pull the MP tray towards you until it stops.

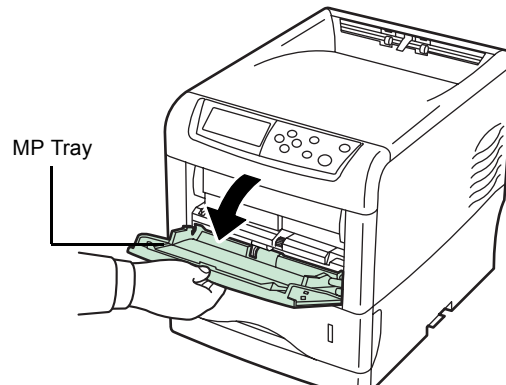

Figure 2-14

- 2** Pull out the subtray.

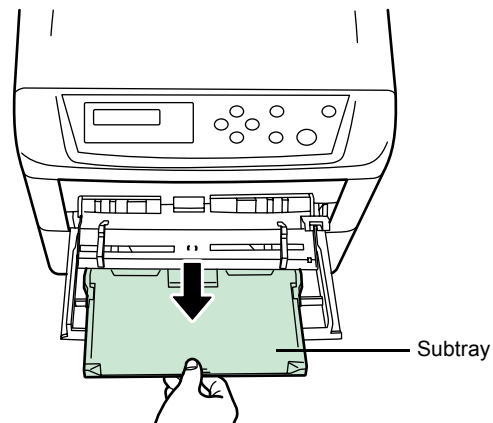

Figure 2-15

- 3** Adjust the position of the paper guides on the MP tray. Standard paper sizes are attached to the MP tray. For standard paper sizes, slide the guides to the position marked correspondingly.

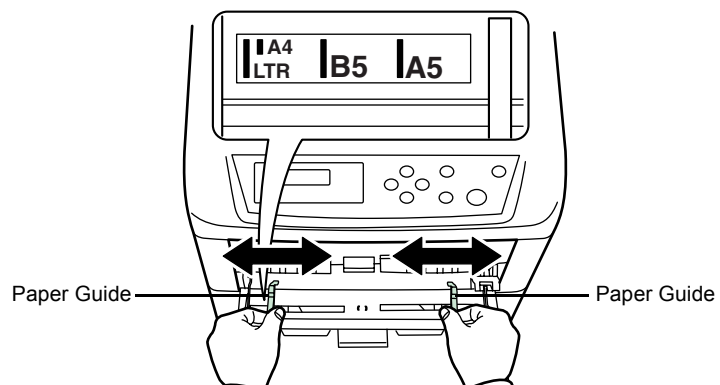

Figure 2-16

4 Align the paper with the paper guides and insert as far as it will go.

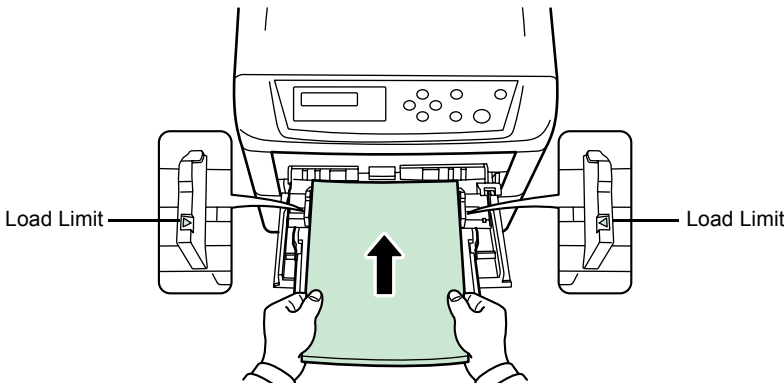

Figure 2-17



Note

- Do not load more paper than will fit under the load limits on the inside of the MP tray.
- If the paper is considerably curled in one direction, for example, if the paper is already printed on one side, try to roll the paper in the opposite direction to counteract the curl. Printed sheets will then come out flat.

Collect		
Incollect		

5 Set the MP tray paper size on the printer's operator panel. Refer to *Chapter 3 Using the Operator Panel, section 3.10.2 Setting MP Tray Paper Size on page 3-69.*

2.4 Special Paper

Besides plain paper, this printer can use the following types of special paper:

Paper type to be used	Paper type to be selected
Thin paper (60 to 64 g/m ²)	Vellum
Thick paper (90 to 200 g/m ²)	Thick
Colored paper	Color
Recycled paper	Recycle
Overhead projector transparencies	Transparency
Postcards	Cardstock
Envelopes	Envelope
Label	Labels

Table 2-5

You can assign one of these special paper type to a paper cassette or MP (multi-purpose) tray by using the printer's operator panel keys. Then, the printer can automatically select the paper cassette or multi-purpose tray to feed the special paper from and internally adjust the electrical parameters for optimum printing performance according to the special paper type. For details, see [Chapter 3 Using the Operator Panel, section 3.10.5 Setting the Cassette Paper Type on page 3-76](#).

Note that some types of special paper do not allow feeding from the paper feeder cassette.

2.4.1 Selecting the Special Paper

Since special paper differs significantly in paper composition and quality, special paper is more likely to cause problems than white bond paper during printing. When using special paper, be sure that they are manufactured for photocopiers and/or page printers.

Before purchasing any special paper, make a test print using the printer and check whether the results are satisfactory.



Note

Kyocera Mita shall not be liable for any danger to a person or machine that is caused by using special paper (e.g., fumes emitted from the special paper).

To avoid problems, stack transparencies, labels, postcards, envelopes, or thick paper on the face-up tray (option).

Major considerations for each type of special paper are given below.

Transparency

Transparencies for overhead projectors must withstand the heat of fusing during the printing process. The recommended transparency product is as follows:

3M CG3700 (Letter, A4)

Transparencies must be placed on the MP (multi-purpose) tray with the long edge towards the printer. To avoid problems, stack transparencies face up on the face-up tray.

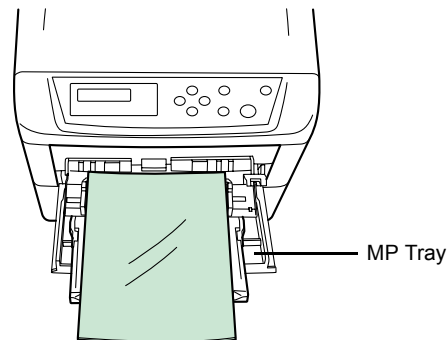

Figure 2-18

When unloading transparencies (e.g., for clearing jams), hold them carefully by the edges to avoid leaving fingerprints on them.

Adhesive-backed labels

Label paper must be fed manually.

For printing on labels, use extreme care so that the adhesive may not come in direct contact with any part of the printer. Adhesives that stick to the drum or rollers will cause printer damage.

Labels consist of three parts. Printing is done onto the top sheet (also called the face sheet). The adhesive contains chemicals. The carrier sheet (also called the backing paper or liner) bears the top sheet. This composition of labels can cause more problems than other print forms during printing.

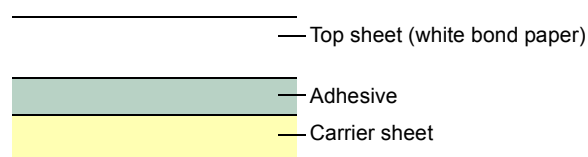

Figure 2-19

When using label paper, do not leave gaps between the arranged labels (i.e., top sheets). Labels arranged with gaps in-between can easily be peeled off during printing, causing serious jam problems.

When the label paper has extra margin around the label's outside edges that correspond to the margins of the printable area, do not remove the extra top sheet from the carrier sheet until printing is finished.

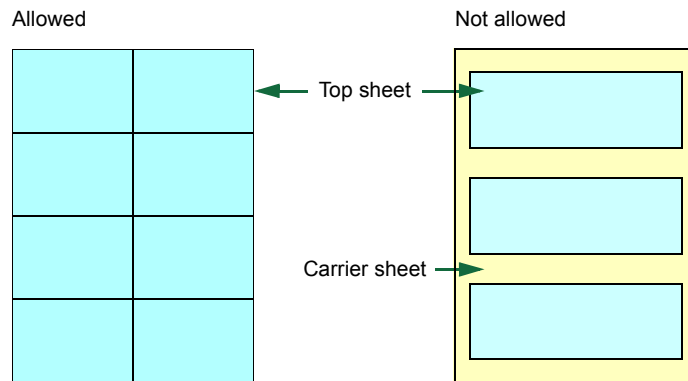

Figure 2-20

When selecting labels, make sure to use only those meeting the following requirements:

Item	Value
Top sheet weight	44 to 74 g/m ² (12 to 20 lb)
Total weight	104 to 151 g/m ² (28 to 40 lb)
Top sheet thickness	0.086 to 0.107 mm (3.9 to 4.2 mils)
Total thickness	0.115 to 0.145 mm (4.5 to 5.7 mils)
Moisture content	4 to 6 % (composite)

Table 2-6

Postcards

Fan the stack of postcards and align the edges before loading them in the MP tray. Make sure the postcards you are going to set are not curled. Feeding curled postcards may cause paper jams.

Some postcards have rough edges on the back (those are created when the paper is cut). In this case, put the postcards on a flat place and rub the edges with, for example, a ruler to smooth them.

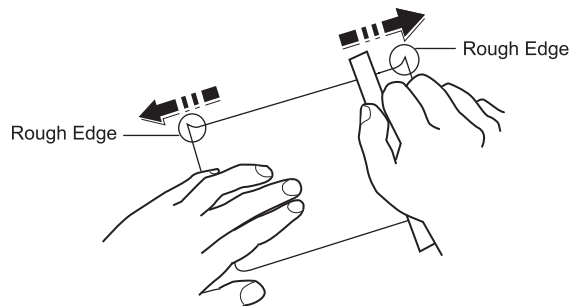

Figure 2-21

Envelopes

Envelopes should be fed in the face-up position, right edge first.

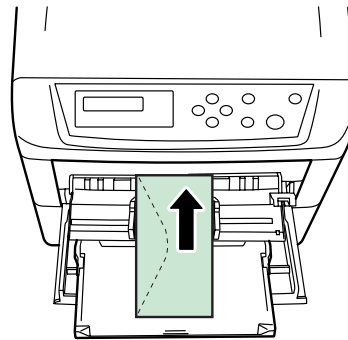

Figure 2-22

Since the composition of an envelope is more complex than that of ordinary paper, it is not always possible to ensure consistent printing quality over the entire envelope surface.

Normally, envelopes have a diagonal grain direction. See section [Grain on page 2-6](#). This direction can easily cause wrinkles and creases when envelopes pass through the printer. Before purchasing envelopes, make a test print to check whether the printer accepts the envelope.

Other handling cautions follow:

- Do not use envelopes that have an encapsulated liquid adhesive.
- Avoid a long printing session for envelopes only. Extended envelope printing can cause premature printer wear.
- If jams do tend to occur, try setting a lesser number of envelopes on the MP tray.
- To avoid jams caused by curled envelopes, stack the printed envelopes no higher than 10 on the output tray.

Thick Paper

Fan the stack of paper and align the edges before loading them in the MP tray. Some types of paper have rough edges on the back (those are created when the paper is cut). In this case, put the paper on a flat place and rub the edges once or twice with, for example, a ruler to smooth them in the same way as described in [Postcards on page 2-18](#). Feeding rough edged paper may cause paper jams.



Note

If the paper jams even after you smooth it out in such a way, set the paper in the MP tray with the leading edge raised up a few millimeters as shown in the illustration.

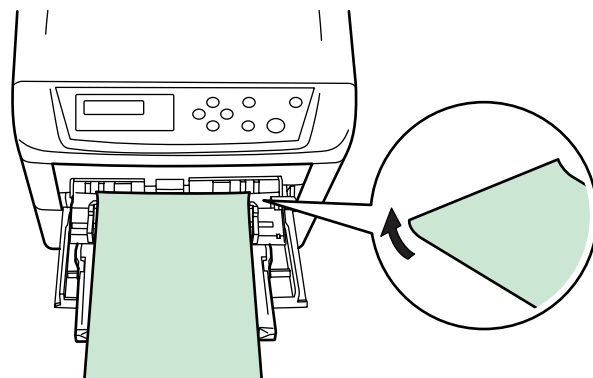

Colored paper

Colored paper should have the same specifications as the white bond paper listed. In addition, the pigments in the paper must be able to withstand the heat of fusing during the printing process (up to 200 °C or 392 °F).

Pre-printed paper

Pre-printed paper should basically be bond paper. The inks on the paper must be able to withstand the heat of fusing during the printing process and must not be adversely affected by silicon oil. Do not use paper with any kind of coating, such as calendar stock.

Recycled paper

Select recycled paper that has the same specifications as white bond paper. See [Table 2-1 on page 2-2](#). Recycled paper, however, does not have to be as white as white bond paper.



Note

Before purchasing recycled paper, make a test using the printer and check whether the print quality is satisfactory.

2.5 Paper Type

The printer is capable of printing under the optimum setting for the type of paper being used.

Setting the paper type for the paper source from the printer's operator panel will cause the printer to automatically select the paper source and print in the mode best suited to that type of paper.

A different paper type setting can be made for each paper source including the MP tray. Not only can preset paper types be selected, but it is also possible for you to define and select customized paper types. See *Chapter 3 Using the Operator Panel, section 3.10.9 Creating Custom Paper Type on page 3-81*.

The following types of paper can be set.

Paper Type	Paper source			
	MP tray	Paper Cassette	Paper Weight	Duplex path (MP tray available only in Cassette mode)
Plain	Yes	Yes	Normal 2	Yes
Transparency	Yes	No	Extra Heavy	No
Preprinted	Yes	Yes	Normal 2	Yes
Labels	Yes	No	Heavy 1	No
Bond	Yes	Yes	Normal 2	Yes
Recycled	Yes	Yes	Normal 2	Yes
Vellum	Yes	No	Light	No
Rough	Yes	Yes	Normal 2	Yes
Letterhead	Yes	Yes	Normal 2	Yes
Color	Yes	Yes	Normal 2	Yes
Prepunched	Yes	Yes	Normal 2	Yes
Envelope	Yes	No	Heavy 1	No
Cardstock	Yes	No	Heavy 2	No
Coated	Yes	No	Normal 2	No
Thick	Yes	No	Heavy 1	No
High quality	Yes	Yes	Normal 2	Yes
Custom 1 (to 8) [†]	Yes	Yes	Normal 2	Yes

Yes: Can be stored No: Cannot be stored

Table 2-7

[†] This is a paper type defined and registered by the user. Up to eight types of user settings may be defined. For details on *Chapter 3 Using the Operator Panel, section 3.10.9 Creating Custom Paper Type on page 3-81*.

Chapter 3 Using the Operator Panel

This chapter provides the information you need to configure the Ecosys Color printer. In general you need to use the operator panel only to make default settings. You can make most changes to the printer settings using the printer driver through the application software.



Note

Changes to printer settings made using a software application override changes made using the operator panel.

You can also rely on other printer utilities such as Kyocera Mita PrintMonitor if you need to change settings that are not available on the printer driver. It will allow you remote access to printer settings. Printer utilities are supplied in the CD-ROM supplied with the printer.

The chapter describes the operator panel in detail, including its menus and the procedures for changing various printer settings.

3.1 Understanding the Operator Panel

The operator panel on the top of the printer has a 2-line by 16-character liquid crystal display (LCD), eight keys, and three indicators (LED).

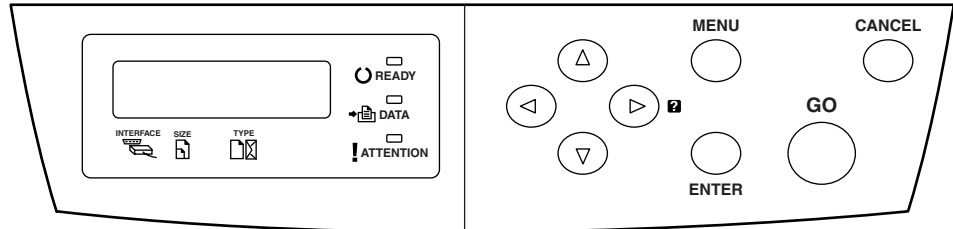

Figure 3-1

Messages that appear on the display and functions of indicators and keys are explained in the sections that follow.

3.1.1 Message Display

The message display on the operator panel shows:

- Status information, the ten messages listed below which are displayed during normal operation.
- Error codes, when the printer requires the operator’s attention; as explained in [Chapter 4 Troubleshooting](#).

Status Information

Message	Meaning
Self test	The printer is performing self-diagnostics after power-up.
Please wait	The printer is warming up and is not ready. When the printer is switched on for the first time, this message will take several minutes.
Please wait (Adding toner)	Toner is currently being replenished. This message may be displayed during continuous printing of a large volume of pages which require a large amount of toner such as with photographs, etc.
Please wait (Calibrating)	The color calibration function is being performed automatically as you powered on the printer. You can also execute this function manually on the operator panel. For details, see section 3.13.13 Color Calibration on page 3-104 .
Ready	The printer is ready to print.
Processing	The printer is receiving data to print. This is also shown when the printer is reading a memory card, hard disk or RAM disk.

Table 3-1

Message	Meaning
Sleeping	The printer is in sleep mode. The printer wakes from sleep mode whenever a key on the operator panel is pressed, the cover is opened or closed, or a print job is received. The printer then warms up and goes on-line. For details on sleep mode, see <i>Sleep Timer Timeout Time on page 3-92</i> .
Cancelling data	Jobs inside the printer are being canceled. To cancel a job, see <i>section 3.1.3 Keys on page 3-6</i> .
Waiting	The printer is waiting for the rest of print job before completing the last page. Pressing the GO key allows you to obtain the last page immediately. See below.
FormFeed TimeOut	The printer is printing the last page after a waiting period.

Table 3-1 (Continued)

Error codes

See *Chapter 4 Troubleshooting*.

3.1.2 Indicators in Message Display

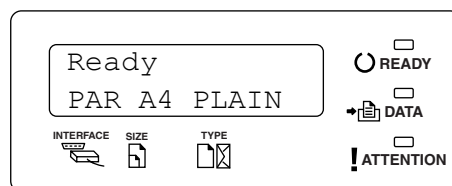

Figure 3-2

Interface Indicator (INTERFACE)

The interface indicator shows the interface that is currently in use:

PAR	Parallel interface is in use.
USB	USB interface is in use.
SER	Serial (RS-232C) interface is in use. (option)
NET	Network interface is in use.
OPT	Network interface is in use. (option)
---	No interface is in use.

Each interface has a timeout time of 30 seconds during which the other interface should wait to receive a print job. Even a print job has been complete on the interface, you should wait for this period until the other interface begins printing the job.

Paper Size Indicator (SIZE)

This indicator indicates:

- While the printer is in standby, the paper size of the current cassette. The default paper cassette is determined by the operator panel keys. For details, see [section 3.10 Paper Handling on page 3-68](#).
- While the printer is printing, the paper size used to format the document to print by the application software.

The abbreviations used to indicate the paper sizes and their dimensions are as follows:

A4	ISO A4 (21 × 29.7 cm)
A5	ISO A5 (14.8 × 21 cm)
A6	ISO A6 (10.5 × 14.8 cm) [†]
B5	JIS B5 (18.2 × 25.6 cm)
B6	JIS B6 (12.8 × 18.2 cm) [†]
LT	Letter (8-1/2 × 11 inches)
LG	Legal (8-1/2 × 14 inches)
MO	Monarch (3-7/8 × 7-1/2 inches) [†]
BU	Business (4-1/8 inches) [†]
DL	ISO DL (11 × 22 cm) [†]
C5	ISO C5 (16.2 × 22.9 cm)
b5	ISO B5 (17.6 × 25 cm)
EX	Executive (7-1/4 × 10-1/2 inches)
#6	Commercial 6-3/4 (3-5/8 × 6-1/2 inches) [†]
#9	Commercial 9 (3-7/8 × 8-7/8 inches) [†]
HA	Japanese Postcard (10 × 14.8 cm) [†]
OH	Return Postcard (20 × 14.8 cm) [†]
O2	Oficio II (8-1/2 × 13 inches)
16K	16 kai (19.7 × 27.3 cm)
ST	Statement (5-1/2 × 8-1/2 inches) [†]
FO	Folio (21 × 33 cm)
Y2	Yokei 2 (11.4 × 16.2 cm) [†]
Y4	Yokei 4 (10.5 × 23.5 cm) [†]
CU	Custom Size (14.8 × 21 cm to 21.6 × 35.6 cm)

[†] Only with MP tray feeding

Paper Type Indicator (TYPE)

This indicator shows the paper type defined for the current paper cassette. The paper type can be manually defined using the operator panel. For more information, see [section 3.10 Paper Handling on page 3-68](#).

The following abbreviations are used:

(none)	Auto	LETTERHEA	Letterhead
PLAIN	Plain paper	COLOR	Colored paper
TRNSPRNCY	Transparency†	PREPUNCH	Pre-punched paper
PREPRINTE	Pre-printed paper	ENVELOPE	Envelope†
LABELS	Labels†	CARDSTOCK	Card stock†
BOND	Bond paper	COATED	Coated paper†
RECYCLED	Recycled paper	THICK	Thick paper†
VELLUM	Vellum†	HIGH QUAL	High-quality paper for color printing
ROUGH	Rough paper	CUSTOM1 (to 8)	Custom 1 (to 8)

† Only with MP tray feeding

READY, DATA, and ATTENTION Indicators

The following indicators light during normal operation and whenever the printer needs operator's attention. Depending on the status of lighting, each indicator has the following meaning:



Indicator	Description
 READY	<p>Flashing. Indicates an error that you can recover by yourself, such as the loose top cover. For details, see Chapter 4 Troubleshooting, section 4.3 Error Messages on page 4-7.</p> <p>On. Indicates that the printer is ready and on-line. The printer prints the data it receives.</p> <p>Off. Indicates that the printer is off-line. Data can be received but will not be printed until the printer is on-line by pressing the GO key. Also, indicates when printing is automatically stopped due to the occurrence of an error. For details see Chapter 4 Troubleshooting, section 4.3 Error Messages on page 4-7.</p>
 DATA	<p>Flashing. Indicates that a data is being received from the computer.</p> <p>On. Indicates either that data received is being processed before printing starts, or that data received is being written to a memory card, hard disk or RAM disk.</p>
 ATTENTION	<p>Flashing. Indicates that the printer requires maintenance or is warming up.</p> <p>On. Indicates the occurrence of a problem or an error. For details, see Chapter 4 Troubleshooting, section 4.3 Error Messages on page 4-7.</p>

Table 3-2

3.1.3 Keys

The operator panel keys are used to configure the printer operation. Note that certain keys have the secondary function.



The printer has a parallel, serial, and an optional network interface. Configuration to the printer settings made with these keys affect only one of these interfaces that is currently active (indicated by the INTERFACE indicator on the message display). See [Interface Indicator \(INTERFACE\)](#) on page 3-3.

GO Key



The **GO** key switches the printer between on-line and off-line. Use this key to:

- Toggle the printer's on-line and off-line states. You can temporarily stop the print job by switching the printer off-line.
- Print and feed out one page when the printer displays `Waiting`.
- Recover from certain errors.
- Recover from the Sleep mode.

CANCEL Key



This key is used to:

- Cancel a printing job.
- Stop the alarm sound.
- Reset numeric values or cancels a setting procedure while using menu system.

To cancel a printing job:

- 1** While the printer displays `Processing`, press the **CANCEL** key.

`Print Cancel?` appears on the message display followed by the interface which the job to cancel is on. The interface is indicated by one of the following message:

```
Parallel
USB
Network
Serial (option serial interface)
Option (option network interface)
```

- 2** Press the **ENTER** key. `Cancelling data` appears on the message display and printing stops after the current page is printed.

MENU Key

MENU



The **MENU** key lets you enter the menu system to change the setup and printing environment of the printer.

Pressing this key during a menu selection will terminate the selection and return the printer to the normal operation.

Arrow Keys

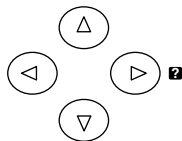

The four arrow keys are used in the menu system to access a desired item or enter numeric values.

The arrow key with the question mark () may be pressed when the paper jam message has appeared on the message display. Then a help message will appear to facilitate jam clearing in the location.

ENTER Key



ENTER

This key is used to:

- Finalize settings of numeric values and other selections.
- Set the paper source when `Use alternative?` is shown in the message display.



Note

If you hold down the ENTER key and press the MENU key when Ready is shown on this printer, the AdministrationID menu will be displayed. This menu is the setting menu for administration under the Account Management System and is normally not used. Press the MENU key to return to the Ready display.

3.2 Using the Menu Selection System

3.2.1 Menu Selection System

This section explains how to use the menu selection system. The **MENU** key on the operator panel allows you to use the menu to set or change the printer environment such as the number of copies to print, emulation, etc., to your specific needs. Settings can be made when Ready is indicated on the printer message display.

The printer obeys the most recently received printer settings sent from the application software, or from the printer driver, which take priority over operator panel settings.

Entering the Mode Selection Menu

Press the **MENU** key when Ready is indicated on the printer message display.

The mode selection menu is displayed.

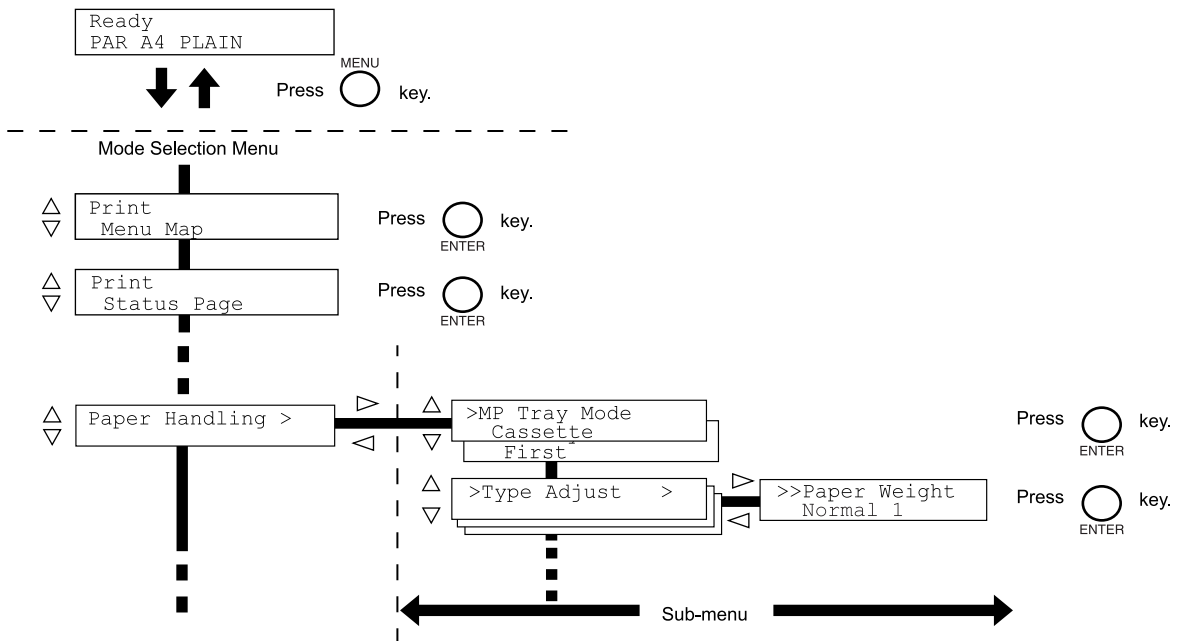

Selecting a Menu

The mode selection menu is hierarchical. Press the Δ or ∇ key to display the desired menu.

- If the selected menu has a sub-menu, > is displayed after the menu.

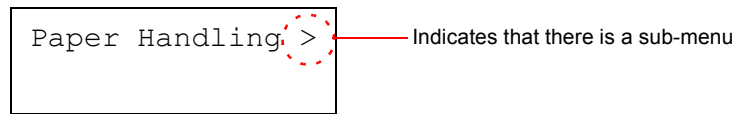

Press the \triangleright key to move to the sub-menu or \triangleleft key to go back.

- > is displayed before the sub-menu.

Indicates that this is the sub-menu

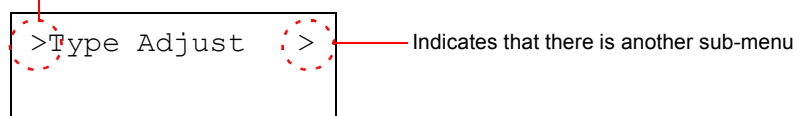

Press the \triangleright key to move to another sub-menu or \triangleleft key to go back.

- >> is displayed before the second sub-menu.

Indicates that this is the second sub-menu

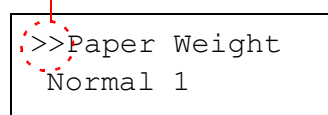

Setting a Menu

Select the desired menu and press the **ENTER** key to set or change the configuration.

Press the Δ or ∇ key to display the desired item and the **ENTER** key to finalize the value or selections set.

Cancelling Menu Selection

If you press the **MENU** key when selecting a menu, the message display returns to Ready.



Note

Settings that are received from application software and the printer driver will take priority over settings made in the operator panel.

3.2.2 Menu System Road Map

The following is the hierarchy diagram of the menu selection system of the printer.
For details about menu selection operations, see [page 3-8](#).

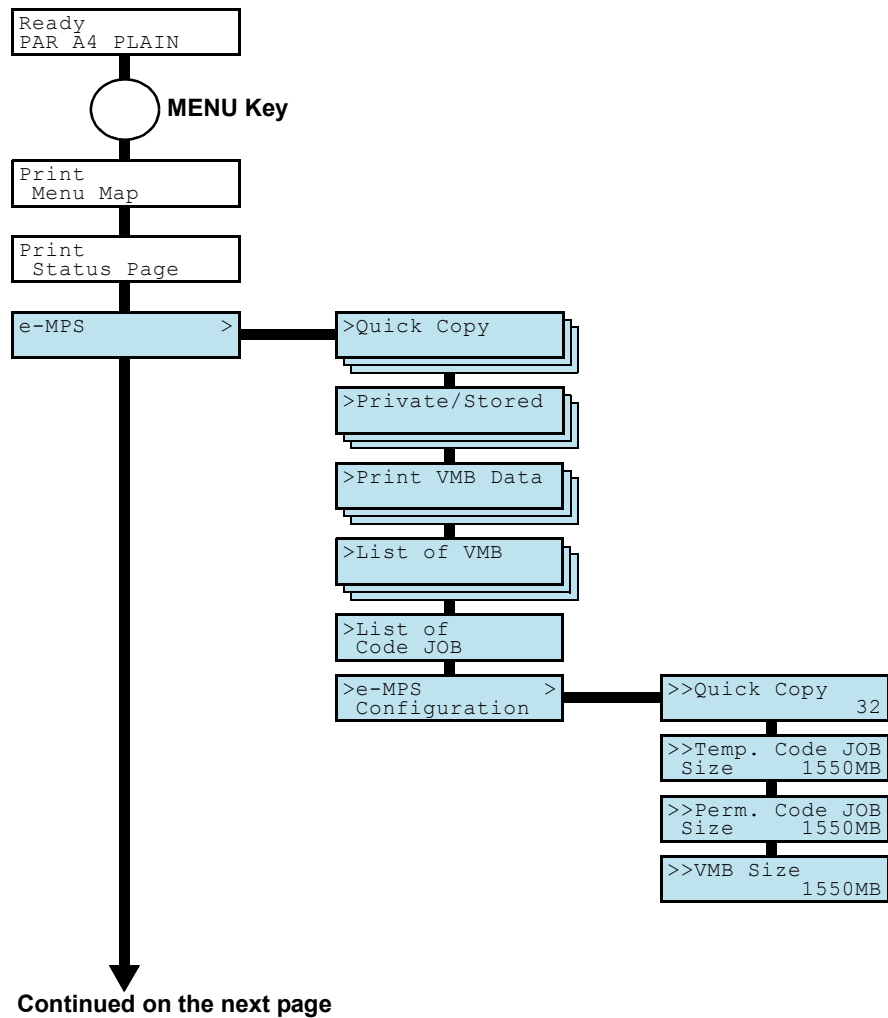

Continued

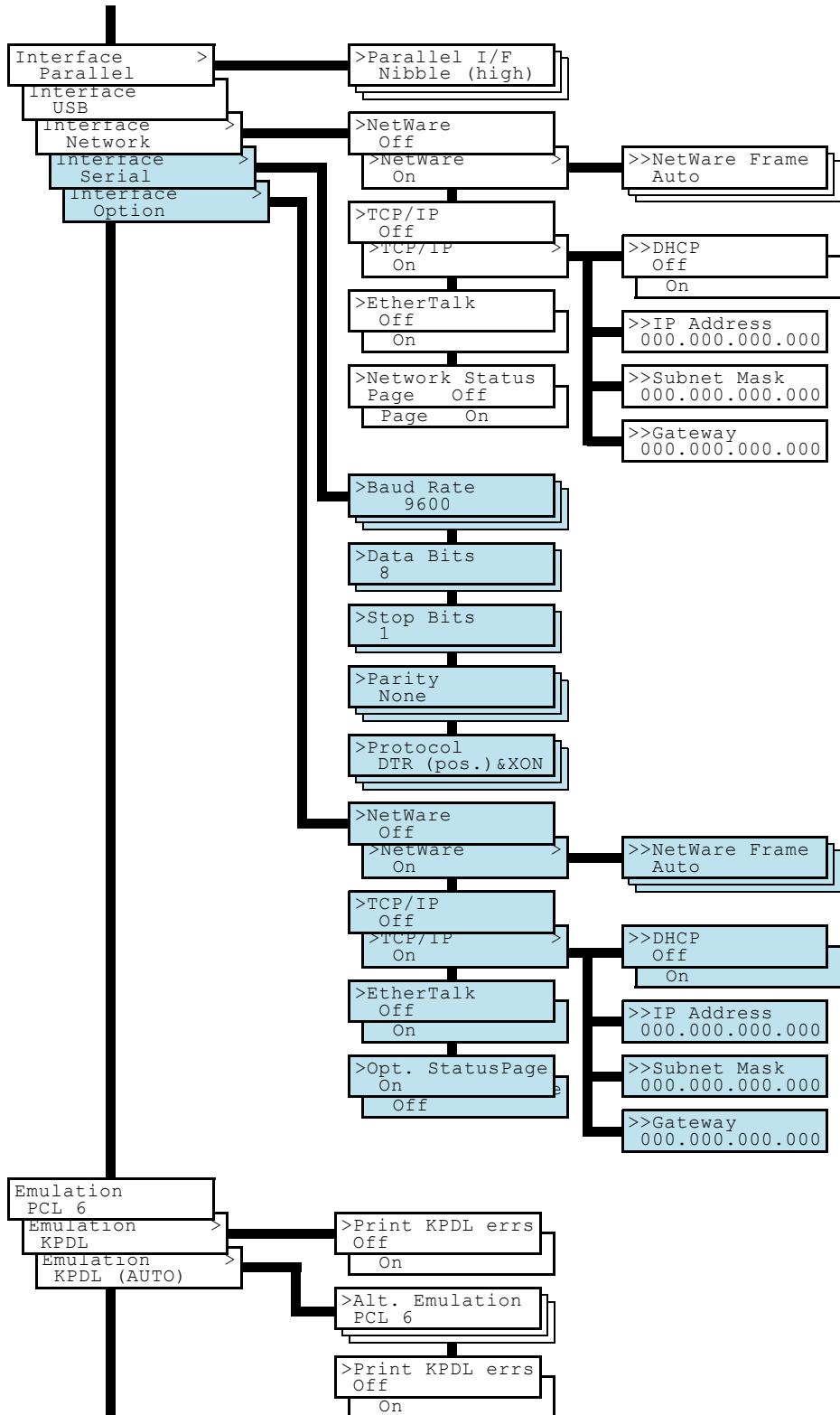

Continued on the next page

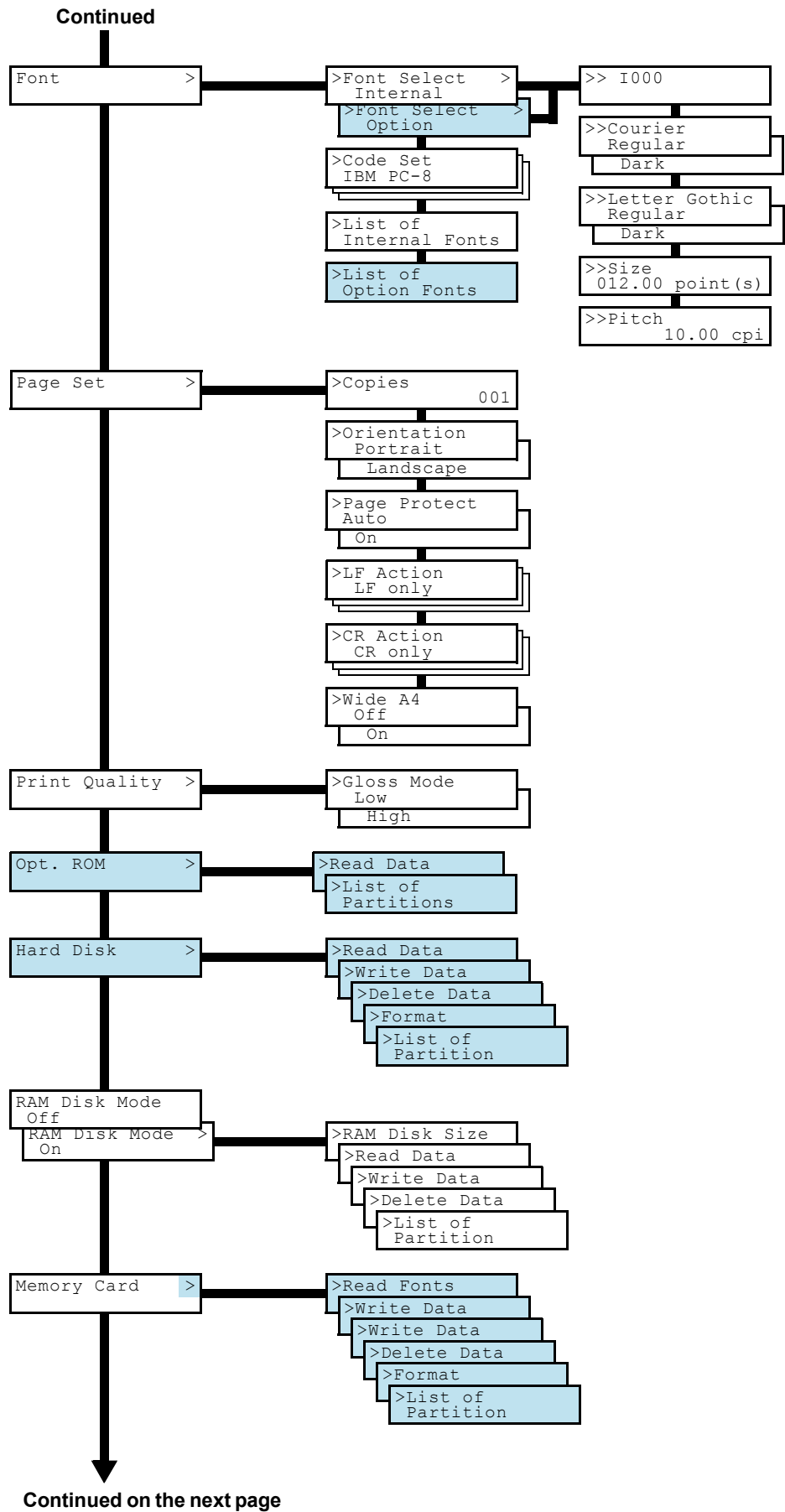

Continued

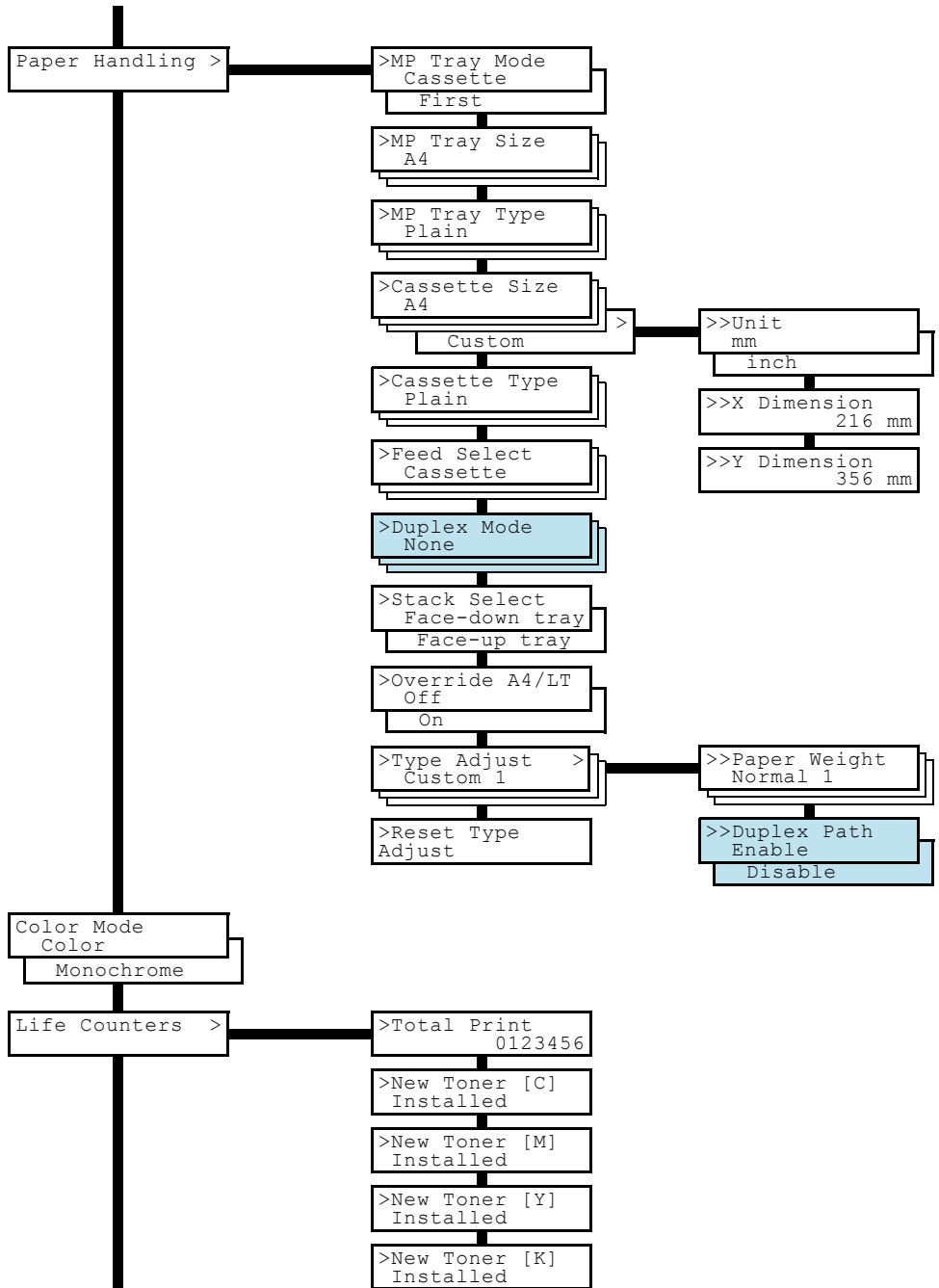

Continued on the next page

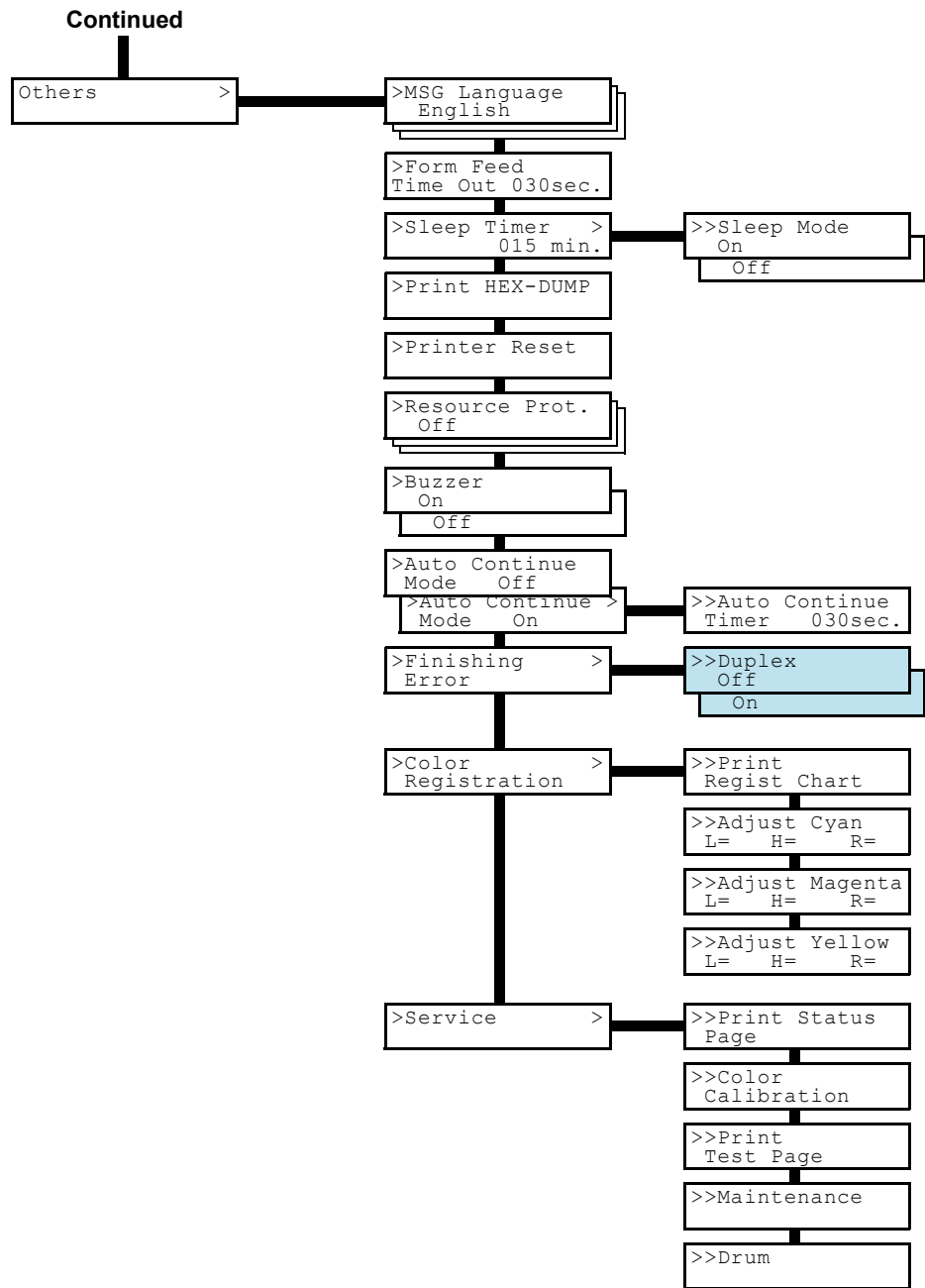

3.3 Menu Map and Status Pages

This section explains the procedure for printing the printer's internal information using the menu selection system. The menu map is useful as a reference to guide yourself through the menu selection system.

The status page is a list of parameters and settings for most basic printer configurations. You may be required to produce a status page when requesting service to the printer.

3.3.1 Printing a Menu Map

The printer prints a full list of menu selection system — Menu Map. Note that menus shown in the list may vary depending on which optional units installed in the printer.

- 1** Press the **MENU** key.
- 2** Press the Δ or ∇ key repeatedly until `Print Menu Map` appears.

```
Print
Menu Map
```

- 3** Press the **ENTER** key. A question mark (?) appears.

```
Print
Menu Map ?
```

- 4** Press the **ENTER** key. The message `Processing` appears and the printer prints a Menu Map.



Figure 3-3

3.3.2 Printing a Status Page

You can check the printer's current status, including available memory space and option settings by printing a status page.

- 1** Press the **MENU** key.
- 2** Press the \triangle or ∇ key repeatedly until `Print Status Page` appears.

```
Print
Status Page
```

- 3** Press the **ENTER** key. A question mark (?) appears.

```
Print
Status Page ?
```

- 4** Press the **ENTER** key again. The message `Processing` appears and the printer prints a status page.

For a sample status page and its full description, see [Understanding the Status Page on page 3-18](#).

Understanding the Status Page

The numbers in the following diagram refer the items explained below the diagram. The items and values on the status page may vary depending on the printer's firmware version.

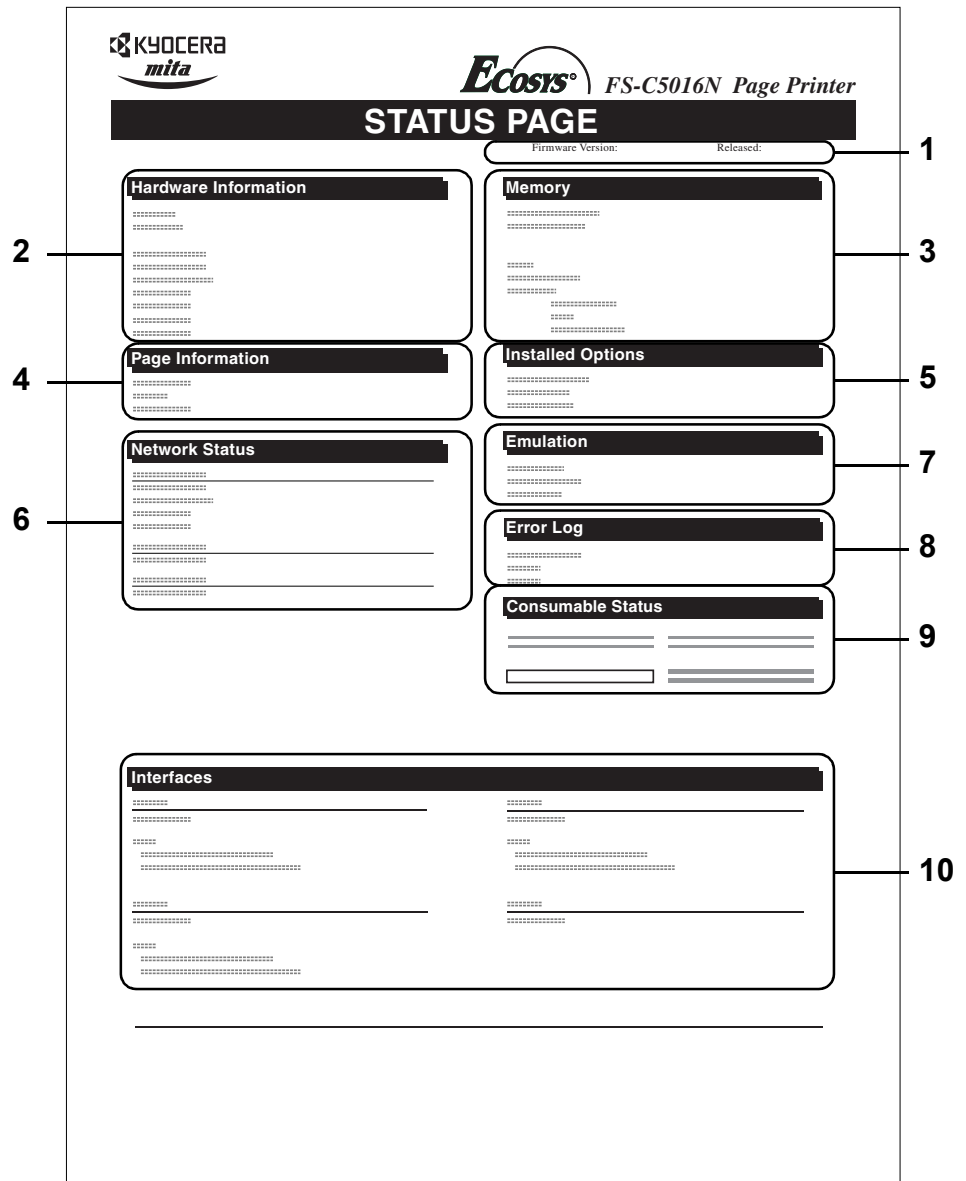

Figure 3-4

1 Software Version

This item shows the version and release date of the printer firmware.

2 Hardware Information

This item shows various printer settings for hardware-related items:

- MP tray paper size and type
- Paper cassette size and type
- Buzzer control
- Host buffer size
- Sleep time timeout time
- Formfeed timeout time

3 Memory

This item shows:

- Standard memory in the printer (96 MB)
- Option memory slot status (Slots 1 and 2) in megabytes
- Total memory in the printer
- Current status of the RAM disk

4 Page Information

This item shows the page related items:

- Number of copies, from 1 to 999
- Total page count

5 Installed Options

This item shows the options installed in the printer:

- Hard disk
- Option ROM
- Memory card

6 Network Status

This item shows the IP address, subnet mask address, and default gateway address for the network interface card in the printer.

7 Emulation

This item shows all available emulations of the printer. The PCL 6 emulation is set as default when the printer is shipped from the factory. The emulations are:

- PCL 6
- KPDL3

8 Error Log

This item shows the last three instances of the following types of errors, listing them in the order of occurrence:

- KPDL (PostScript) errors
- Memory overflow
- Print overrun
- File-not-found

The most recent error is displayed on the topmost line of Error Log. Error information is cleared when the printer is powered off.

The error log information is intended for service purpose.

9 Consumable Status

This item shows the approximate level of remaining toner. When the value is 100, the toner container is full. The closer to 0, the smaller the amount of remaining toner.

10 Interface Information

This information shows the emulation and the default font for all interfaces installed in the printer.

3.4 e-MPS

e-MPS is an abbreviation for ‘enhanced-Multiple Printing System’ which implements the following functions that are available from the printer driver:

- Job Retention
- Job Storage

In either job mode, when printing a document, the print data is transferred from the computer to the printer then stored on the printer’s hard disk. Since copies of the document are printed using the stored data, printing is performed faster with less computer spooling time and less network traffic.



Note

- **To use the e-MPS system, an optional hard disk must be installed in the printer. For details, see [Appendix A Options](#).**
- **The RAM disk may also be used in the Proof-and-Hold and Private Print modes. See [Using the RAM Disk on page 3-66](#) for details on RAM disk setup.**

Job Retention

Job Retention has four modes as summarized below. These modes are selected when you choose on the printer driver through the application software:

	Quick Copy	Proof-and-Hold	Private Print	Stored Job
Primary function	To later print additional copies	To proof the first copy before printing multiple copies	To hold the document in printer to prevent unauthorized access	To electronically store documents such as fax cover pages
Start storing by	Printer driver	Printer driver	Printer driver	Printer driver
On terminating print setting from application software	Prints simultaneously	Prints one copy simultaneously	Does not print	Does not print
Retrieved by	Operator panel	Operator panel	Operator panel	Operator panel
Default number of copies printed at retrieval	Same as storing (can be changed)	One less (can be changed)	Same as storing (can be changed)	One (can be changed)
Maximum number of jobs stored [†]	32, expandable to 50	32, expandable to 50	Depends on the hard disk capacity (Private jobs are deleted automatically once it is retrieved.)	Depends on the hard disk capacity
PIN security	No	No	Yes	Yes (if necessary)
Data after printing	Stored	Stored	Deleted	Stored
Data at power off	Deleted	Deleted	Deleted	Stored
Hard disk required	Yes	No	No	Yes

Table 3-3

[†] Jobs in excess will cause the earlier ones to be deleted.

Job Storage

Job storage stores print jobs either temporarily or permanently, or in virtual mailboxes, as you click an appropriate radio button on the printer driver when printing from a computer.

Virtual Mailbox

Virtual mailbox is part of Job Storage, which stores print jobs on the hard disk without printing. It enables you to retrieve jobs later from the operator panel or the **KM-NET Printer Disk Manager utility** in the CD-ROM.

Each mailbox may be used by an individual who desires to share the printer in this mode. By default, each mailbox is numbered from 'Tray 001,' 'Tray 002,' ... etc. To 'post' a job in one of these mailboxes, you assign a numbered or named mailbox on the printer driver when printing.

To retrieve the stored job for printing, see *Retrieving Jobs from Virtual Mailbox (VMB) on page 3-28*.



Note

The virtual mailbox can be used in PCL 6 emulation only.

3.4.1 Using Quick Copy

This mode enables you to print the requested number of copies of a job, simultaneously storing the job on the hard disk. When additional copies are required, you can reprint the required number of copies from the printer operator panel. To print a job as a quick copy job, see *KX Printer Drivers Operation Guide*.

The default number of print jobs that can be stored on the hard disk is 32. This value can be increased to up to 50 from the e-MPS Configuration menu. For details, see *Changing the Maximum Number of Quick Copy/Proof-and-Hold Jobs on page 3-30*. When the number of jobs reaches the limit, the oldest job will be overwritten by the new one.

When the printer is turned off, all stored jobs will be deleted.

Printing Additional Copies using Quick Copy

To print additional copies of a job stored in the printer:

- 1** Press the **MENU** key.
- 2** Press the Δ or ∇ key repeatedly until e-MPS > appears.

```
e-MPS      >
```

- 3** Press the \triangleright key.
- 4** Press the Δ or ∇ key repeatedly until >Quick Copy appears followed by the user name (Harold, in this example). The user name is assigned at printing using the printer driver.

```
>Quick Copy
Harold
```

- 5** Press the **ENTER** key. A blinking question mark (?) appears before the user name.

```
>Quick Copy
?Harold
```

- 6** Press the Δ or ∇ key to display the desired user name, Arlen, in this example.

```
>Quick Copy
?Arlen
```

- 7** Press the **ENTER** key. The job name entered in the printer driver (Report, in this example) appear with a blinking question mark (?) before the letters.

```
>Arlen
?Report
```

- 8** Press the Δ or ∇ key to scroll to the desired job title.
- 9** Press the **ENTER** key. The number of copies to be printed can be set. To increase the copy count, press the Δ key; to decrease the copy count, press the ∇ key.

```
>Report
Copies      001
```

- 10** Press the **ENTER** key to finalize the copy count. The printer prints the specified number of copies for the job.

Deleting a Quick Copy Job

All quick copy jobs are automatically deleted when the printer is turned off. If you desire to explicitly delete a stored quick copy job, proceed as follows:

- 1** Follow steps 1 through 8 in the above section to let the title of the job to be deleted displayed.
- 2** When the title of the job to be deleted is displayed, e.g. `Report`, below, press the **ENTER** key. The cursor below the copy count starts to blink.

```
>Report
Copies      001
```



- 3** Press the ∇ key repeatedly until `Delete` appears below the title.

```
>Report
Delete
```

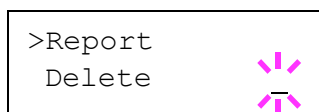

- 4** Press the **ENTER** key. The stored quick copy job is deleted.

3.4.2 Using Proof-and-Hold

When you print multiple copies, this mode first prints one copy so that you can proof it before continuing to print the remaining copies. Since you can proof the printouts before printing the remaining copies, wastage of paper can be reduced.

The printer prints one copy and, at the same time, saves the print job on the hard disk/RAM disk. You can also change the number of copies when resuming printing from the operator panel.

When the printer is turned off, all stored jobs will be deleted.

Printing Remaining Copies of a Proof and Hold Job

Printing a Proof-and-Hold job on the operator panel is similar to printing a quick copy job. See *Printing Additional Copies using Quick Copy on page Chapter 3-22*.

3.4.3 Printing a Private Print/Stored Job

In private printing, you can specify that a job is not printed until you release the job from the operator panel. At sending the job from the application software, you can specify a 4-digit access code in the printer driver. The job is released for printing by entering the access code on the operator panel. Thus, this function ensures confidentiality of the print job.

In the stored job mode, access codes are not mandatory, but can be set on the printer driver if printing with the PIN security is required. Then, the access code must be entered on the operator panel to print a stored job. Print data will be stored in the hard disk after printing. See *KX Printer Drivers Operation Guide* for the driver settings.

Releasing a Private/Stored Job

- 1** Press the **MENU** key.
- 2** Press the Δ or ∇ key repeatedly until e-MPS > appears.

```
e-MPS      >
```

- 3** Press the \triangleright key.
- 4** Press the Δ or ∇ key repeatedly until >Private/Stored appears. The name entered in the printer driver (Harold, in this example) also appears.

```
>Private/Stored
Harold
```

- 5** Press the **ENTER** key. A blinking question mark (?) appears before the user name.

```
>Private/Stored
?Harold
```

- 6** Press the Δ or ∇ key to display the desired user name (Arlen, in this example).

```
>Private/Stored
?Arlen
```

- 7** Press the **ENTER** key. The user name and the job name (Agenda, in this example) entered in the printer driver appear with a blinking question mark (?).

```
>Arlen
?Agenda
```

- 8** Press the Δ or ∇ key to display the desired job title.

- 9** Press the **ENTER** key. The ID input line appears. Enter the four-digit access code entered in the printer driver and press the **ENTER** key.

```
>Agenda
ID      0000
```



To enter the ID, press the ◀ or ▶ key to move the cursor to the number to be changed and then enter the correct number by pressing the △ or ▽ key.

- 10** You can set the number of copies to be printed. To increase the copy count, press the △ key; to decrease the copy count, press the ▽ key.

```
>Agenda
Copies  001
```



- 11** Press the **ENTER** key to finalize the copy count. The printer prints the specified number of copies for the job.

Deleting a Private/Stored Job

You can individually delete stored jobs by performing the following procedure. Jobs saved using Private Print will be automatically deleted if you turn the power off after printing, but jobs saved using Stored Job will not be deleted automatically.

- 1** Follow steps 1 through 8 in the above section.
- 2** When the title of the job to be printed is displayed (Agenda, in this example), press the **ENTER** key. Enter the four-digit access code entered in the printer driver and press the **ENTER** key.

```
>Agenda
Copies  001
```



- 3** Press the ▽ key repeatedly until Delete appears for the number of copies.

```
>Agenda
Delete
```

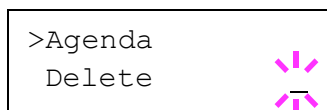

- 4** Press the **ENTER** key. The private job is deleted from the hard disk.

Printing a Code Job

Install the KM-NET Job Manager software from the CD-ROM supplied with the printer. To do this, from the CD-ROM **Main Menu**, select **Printer Utilities > Install KM-NET Job Manager**.

- 1** Browse through Windows **Start > Programs > KYOCERA MITA > KM-Net > Job Manager**.
- 2** Enter the password for the software. **Job Manager** will start.
- 3** Click the **Add printer** icon (below). Select the **Local** or **Network** port.



Note

If you use the local parallel port to connect to the printer, make sure that the printer driver is set to print to a local port. To check this out, click the **Details** tab of the printer **Properties**, and note the **Print to the following port** setting.

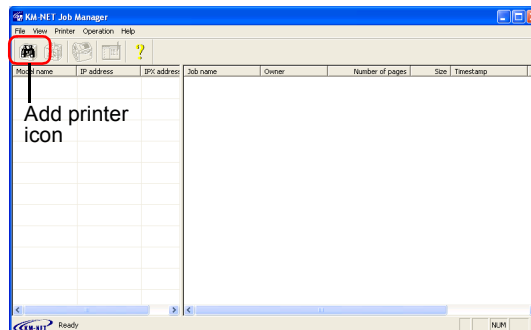

- 4** Follow the wizard until the **Select printer** dialog box is reached. When the printer is found in the **Printer List**, click (highlight) it, then **Finish**.
- 5** Double click **Model Name** on the list. The jobs currently stored in the printer are shown. To print the job, right click **Job name** and then click **Print** on the drop down list that appears.

It is possible to select more than one job at a time by left clicking a job one by one while pressing the **Ctrl** key on the computer keyboard.

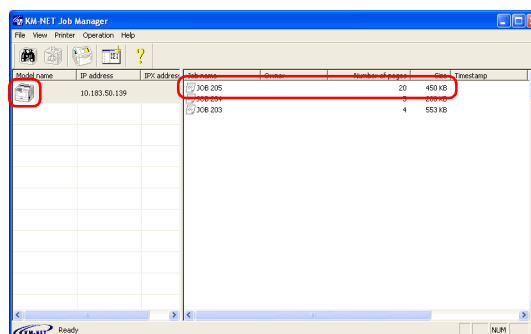

The job remains intact even after printing. To permanently delete the job in the hard disk, right click the job name on **Job Manager**, then click **Delete** on the drop down list that appears.

Printing a List of Code Jobs

If you select Permanent Job Storage on the printer driver, you can have a List of Code Job printed using the operator panel.

- 1** Press the **MENU** key.
- 2** Press the Δ or ∇ key repeatedly until e-MPS > appears.

```
e-MPS >
```

- 3** Press the \triangleright key.
- 4** Press the Δ or ∇ key repeatedly until >List of Code JOB appears.

```
>List of
Code JOB
```

- 5** Press the **ENTER** key. A question mark (?) appears.

```
>List of
Code JOB ?
```

- 6** Press the **ENTER** key again. The printer prints a Code Job list as shown in [Figure 3-5](#) below.

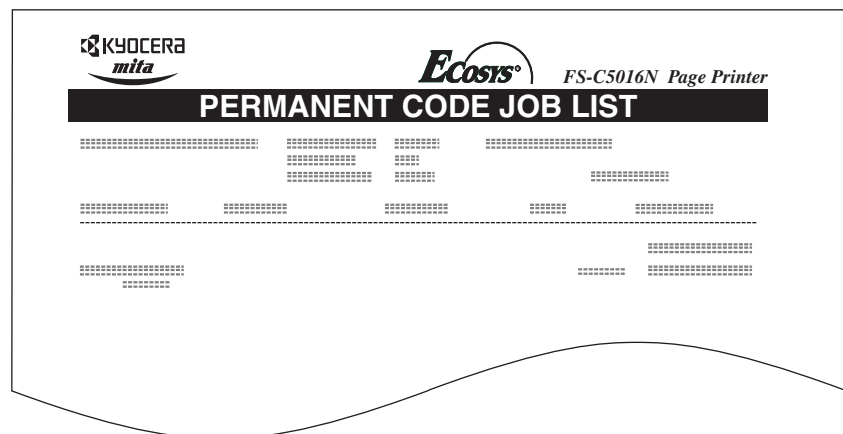

Figure 3-5

3.4.4 Retrieving Jobs from Virtual Mailbox (VMB)

To retrieve the jobs posted in the virtual mailbox, proceed as follows.

- 1** Press the **MENU** key.
- 2** Press the Δ or ∇ key repeatedly until e-MPS > appears.

```
e-MPS      >
```

- 3** Press the \triangleright key.
- 4** Press the Δ or ∇ key repeatedly until >Print VMB Data appears. The virtual mailbox number will also appear.

```
>Print VMB Data
Tray001:
```

If you have named the virtual mailbox with an alias on the printer driver, the alias (Richard, in this example) will follow the number:

```
>Print VMB Data
Tray001:Richard
```

- 5** Press the **ENTER** key. A blinking question mark (?) appears.

```
>Print VMB Data
Tray001?Richard
```

- 6** Press the **ENTER** key. The document in the mailbox is printed and automatically deleted from the mailbox.

Printing a List of VMB

A Virtual Mailbox list includes the jobs currently stored in the mailboxes.

- 1** Press the **MENU** key.
- 2** Press the Δ or ∇ key repeatedly until e-MPS > appears.

```
e-MPS      >
```

- 3** Press the \triangleright key.

- 4** Press the Δ or ∇ key repeatedly until >List of VMB appears.

```
>List of VMB
```

- 5** Press the **ENTER** key. A question mark (?) appears.

```
>List of VMB ?
```

- 6** Press the **ENTER** key again. The printer prints a list of jobs currently posted in the virtual mailboxes as shown in [Figure 3-6](#) below.

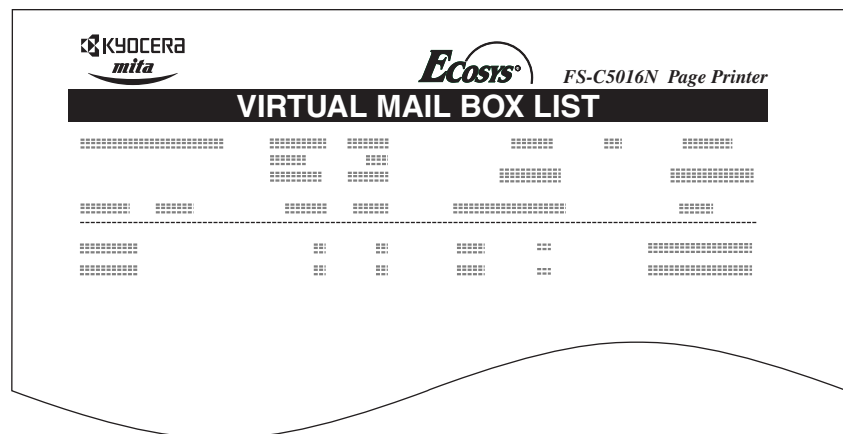

Figure 3-6

3.4.5 Changing e-MPS Configuration

You can change the following parameters for e-MPS operation:

- Maximum number of Quick Copy/Proof-and-Hold jobs
- Maximum space assigned to temporary code jobs
- Maximum space assigned to permanent code jobs
- Maximum space assigned to virtual mailboxes



Note

The total amount of storage areas specified must not exceed the total size of the hard disk. Otherwise, you may only be able to accommodate print jobs of a smaller amount of print jobs than specified.

Changing the Maximum Number of Quick Copy/Proof-and-Hold Jobs

This changes maximum number of Quick Copy/Proof-and-Hold jobs from 0 to 50. The default is 32.

- 1 Press the **MENU** key.
- 2 Press the Δ or ∇ key repeatedly until e-MPS > appears.

```
e-MPS >
```

- 3 Press the \triangleright key.
- 4 Press the Δ or ∇ key repeatedly until >e-MPS Configuration > appears.

```
>e-MPS >
Configuration
```

- 5 Press the \triangleright key.
- 6 Press the Δ or ∇ key repeatedly until >>Quick Copy appears.

```
>>Quick Copy
32
```

- 7 Press the **ENTER** key. A blinking cursor ($_$) appears.

```
>>Quick Copy
32
```

- 8 Press the Δ or ∇ key to increase or decrease the value at the blinking cursor. The value can be set between 0 and 50. Use the \triangleright and \triangleleft keys to move the cursor right and left.
- 9 When the desired maximum number of jobs is set, press the **ENTER** key.

- 10** Press the **MENU** key. The display returns to Ready.

Maximum Space Assigned to Temporary Code Jobs

This changes the hard disk space that holds temporary code jobs. You can change the maximum space from 0 to 9999 (megabytes). The actual maximum size depends on the size of free hard disk space, however. The default size is 1/6 of the total hard disk space, rounded off in unit of 50 MB. For example, if the total hard disk space is 10 GB, the default size is 1550 MB.

- 1** Press the **MENU** key.
- 2** Press the Δ or ∇ key repeatedly until e-MPS > appears.

```
e-MPS >
```

- 3** Press the \triangleright key.
- 4** Press the Δ or ∇ key repeatedly until >e-MPS Configuration > appears.

```
>e-MPS >
Configuration
```

- 5** Press the \triangleright key.
- 6** Press the Δ or ∇ key repeatedly until >>Temp. Code JOB Size appears.

```
>>Temp. Code JOB
Size      1550MB
```

- 7** To change the maximum disk space, press the **ENTER** key. A blinking cursor () appears.

```
>>Temp. Code JOB
Size      1550MB
```

- 8** Press the Δ or ∇ key to increase or decrease, respectively, the value at the blinking cursor. Use the \triangleright and \triangleleft keys to move the cursor right and left.
- 9** When the desired size is displayed, press the **ENTER** key.
- 10** Press the **MENU** key. The display returns to Ready.

Maximum Space Assigned to Permanent Code Jobs

This changes the hard disk space that holds permanent code jobs. You can change the maximum space from 0 to 9999 (megabytes). The actual maximum size depends on the size of free hard disk space, however. The default size is 1/6 of the total hard disk space, rounded off in unit of 50 MB. For example, if the total hard disk space is 10 GB, the default size is 1550 MB.

- 1** Press the **MENU** key.
- 2** Press the Δ or ∇ key and select e-MPS >.

```
e-MPS      >
```

- 3** Press the \triangleright key.
- 4** Press the Δ or ∇ key and select >e-MPS Configuration >.

```
>e-MPS      >
Configuration
```

- 5** Press the \triangleright key.
- 6** Press the Δ or ∇ key and select >>Perm. Code JOB Size.

```
>>Perm. Code JOB
Size      1550MB
```

- 7** Press the **ENTER** key, the message display shows a blinking cursor (|).

```
>>Perm. Code JOB
Size      1550|MB
```

- 8** Press the Δ or ∇ key to increase or decrease, respectively, the value at the blinking cursor. Use the \triangleright and \triangleleft keys to move the cursor right and left.
- 9** When the desired size is displayed, press the **ENTER** key.
- 10** Press the **MENU** key and the display returns to Ready.

Maximum Space Assigned to Virtual Mailboxes (VMB)

This changes the hard disk space for virtual mailboxes. You can change the maximum space from 0 to 9999 (megabytes). The actual maximum size depends on the size of free hard disk space, however. The default size is 1/6 of the total hard disk space, rounded off in unit of 50 MB. For example, if the total hard disk space is 10 GB, the default size is 1550 MB.

- 1** Press the **MENU** key
- 2** Press the Δ or ∇ key and select e-MPS >.

```
e-MPS >
```

- 3** Press the \triangleright key.
- 4** Press the Δ or ∇ key and select >e-MPS Configuration >.

```
>e-MPS >
Configuration
```

- 5** Press the \triangleright key.
- 6** Press the Δ or ∇ key and select >>VMB Size.

```
>>VMB Size
1550MB
```

- 7** To change the maximum size, press the **ENTER** key. The message display shows a blinking cursor ().

```
>>VMB Size
1550  MB
```

- 8** Press the Δ or ∇ key to increase or decrease, respectively, the value at the blinking cursor. Use the \triangleright and \triangleleft keys to move the cursor right and left.
- 9** When the desired size is displayed, press the **ENTER** key.
- 10** Press the **MENU** key to exit the menu selection.

3.5 Changing the Interface Parameters

The printer is equipped with both a parallel and USB interfaces. Optional serial interface board kit and network interface card can also be installed. Various printing environment parameters such as the default emulation can be changed independently on different interfaces by using the printer's menu selection system. Select the interface to apply the changes in the procedure described below.



This interface selection described below does not select which interface data will be received from. The printer automatically selects an interface data to be received.

3.5.1 Changing Parallel Interface Mode

The parallel interface supports a bi-directional/high-speed mode according to IEEE standards. Normally, this interface is used under the default setting `Auto`. For details, see [Appendix B Computer Interface](#). After setting the interface, be sure to reset the printer or turn the power off at least once. The new setting will be enabled thereafter. You can select from the following:

- Auto (default)
- Nibble/high speed
- High speed
- Normal

- 1** Press the **MENU** key.
- 2** Press the Δ or ∇ key repeatedly until `Interface >` appears.
- 3** If the interface is other than parallel, press the **ENTER** key. A blinking question mark (?) appears.

```
Interface
? Serial
```

- 4** Press the Δ or ∇ key repeatedly until `Parallel` appears.

```
Interface
? Parallel
```

- 5** Press the **ENTER** key again. The question mark disappears.
- 6** To change the parallel interface mode, press the \triangleright key. The current communication mode appears.

- 7** To change the communication mode, press the **ENTER** key. A blinking question mark (?) appears.

```
>Parallel I/F
? Nibble (high)
```

- 8** Press the Δ or ∇ key to scroll through the following communication modes:

```
Nibble (high)
Auto
Normal
High Speed
```

- 9** When the desired communication mode is displayed, press the **ENTER** key.

- 10** Press the **MENU** key to exit the menu selection.

3.5.2 Changing Serial Interface Parameters



Note

This section applies to the printer having the optional serial interface board kit (IB-11) installed.

You can confirm or change the serial interface parameters including baud rate, data bits, stop bits, parity, and protocol. These parameters must match those of the computer's serial interface.

- 1** Press the **MENU** key.
- 2** Press the Δ or ∇ key repeatedly until `Interface >` appears.
- 3** If the interface is other than serial, press the **ENTER** key. A blinking question mark (?) appears.

```
Interface
? Parallel
```

- 4** Press the Δ or ∇ key repeatedly until `Serial` appears.

```
Interface
? Serial
```

- 5** Press the **ENTER** key again.
- 6** Press the \triangleright key. One of the following serial parameters is indicated (Baud rate for example).

3.5 Changing the Interface Parameters

Pressing the Δ or ∇ key toggles through the serial parameters as follows. To change the serial parameter, press the **ENTER** key. Use the Δ or ∇ key to change the value or selection.

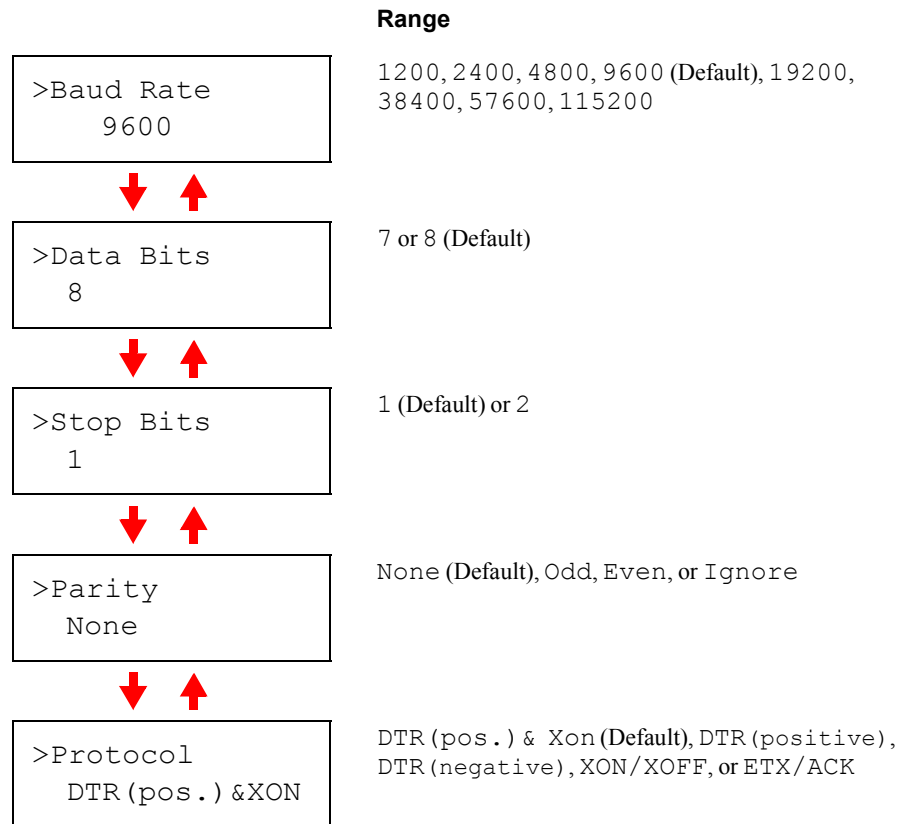

For example, to change baud rate from 9600 to 115200, display the baud rate menu following the above procedure. When the display shows baud rate, 9600 (bps), press the **ENTER** key. A blinking question mark (?) appears.

```
>Baud Rate
? 9600
```

Press the Δ or ∇ key to scroll through values. When 115200 is displayed, press the **ENTER** key. Press the **MODE** key to exit the menu selection.



Some computers may not be able to handle a baud rate of 115200 bps. If you set the baud rate to 115200 and encounter communication problems, select a lower baud rate.

3.5.3 Changing Network Interface Parameters

This printer supports TCP/IP, NetWare and EtherTalk protocols. In addition, you can install the optional network interface card in the option interface slot.

Using the operator panel, you can:

- Activate or deactivate TCP/IP, NetWare, and AppleTalk
- Activate or deactivate DHCP
- Enter IP address, subnet mask address, and default gateway address
- Determine whether to print a network status page when the printer is turned on

To confirm or change network card parameters, proceed as follows:

- 1** Press the **MENU** key.
- 2** Press the Δ or ∇ key repeatedly until `Interface >` appears.
- 3** If the current interface is other than network, press the **ENTER** key. A blinking question mark (?) appears.

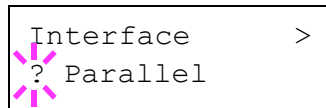

```
Interface >
? Parallel
```

If the optional network interface card is installed in the printer, `Option` will be displayed. The setting procedure is basically the same even in this case.

- 4** Press the Δ or ∇ key repeatedly until `Network` appears.

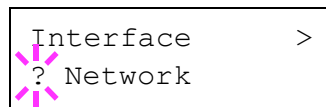

```
Interface >
? Network
```

- 5** Press the **ENTER** key again.

- 6** Press the \triangleright key. One of the following menus is indicated. To change settings for the item, press the **ENTER** key. Use the \triangle or ∇ key to change the value or selection.

```
>NetWare      >
  On
```



```
>TCP/IP      >
  On
```



```
>EtherTalk
  Off
```



```
>Network Status
  Page  Off
```

Range

Set this item to On when you connect to a network using NetWare. In submenu (>), frame mode can be selected from Auto, 802.3, Ethernet II, 802.2, and 802.3SNAP.

Set this item to On when you connect to a network using TCP/IP. Submenu (>) has items including DHCP, IP address, subnet mask address, and gateway address. To resolve IP address for the network card, see [3.5.4 Resolving IP Address](#) below.

EtherTalk must be activated (On) for networking with Macintosh computers.

When the item is set to On, the printer prints out a network status page when it prints the printer status. See [Printing a Network Interface Status Page on page 3-40](#).

- 7** Activate the appropriate protocol that is required to connect the printer to the network. To activate a protocol, let the protocol displayed, press the **ENTER** key, press the \triangle or ∇ key to change from Off to On, and press the **ENTER** key.
- 8** Press the **MENU** key. The display returns to Ready. You can print a network status page to confirm that the IP address, subnet mask address, and the gateway address have been properly set. To print a network status page, see [Printing a Network Interface Status Page on page 3-40](#) which follows.

3.5.4 Resolving IP Address

To connect the printer to the network using TCP/IP protocol, you must set the IP address on the printer. The IP address must be unique to the printer and should be obtained from your network administrator.

- 1 Activate TCP/IP protocol in the manner described above.

```
>TCP/IP      >
  On
```

- 2 Enter the submenu by pressing the \triangleright key. Each time you press the \triangle or ∇ key, the selection changes as shown below.

```
>>DHCP
  Off
```



```
>>IP Address
  000.000.000.000
```



```
>>Subnet Mask
  000.000.000.000
```



```
>>Gateway
  000.000.000.000
```

- 3 When \gg IP Address is displayed, press the **ENTER** key. A blinking cursor ($_$) appears at the last digit.

```
>>IP Address
  000.000.000.000_
```

- 4 Press the \triangle or ∇ key to increase or decrease, respectively, the value at the blinking cursor. Use the \triangleright and \triangleleft keys to move the cursor right and left.

- 5 When the IP address is entered, press the **ENTER** key.

- 6 Press the \triangle or ∇ key to move to Subnet Mask. Perform the same procedure to complete entering the subnet mask address.

- 7 Then, press the \triangle or ∇ key to move to Gateway. Perform the same procedure to complete entering the subnet mask address.

- 8 Press the **MENU** key. The display returns to Ready. You can print a network status page to confirm that the IP address, subnet mask address, and the gateway address have been properly set. To print a network status page, see [Printing a Network Interface Status Page](#) which follows.

Printing a Network Interface Status Page

You can have your printer print out a network status page when the printer prints the status page. The network status page shows the network addresses, and other information under various network protocols about the network interface card. The default setting is `Off` (print disable).



Printing out a network interface status page may not be possible with the optional network interface card. For details, see the manual for the network interface.

A sample network status page is shown on [Figure 3-7 on page 3-41](#).

- 1 Press the **MENU** key.
- 2 Press the **ENTER** key repeatedly until `Interface >` appears.

```
Interface >
Parallel
```

- 3 If the interface is other than network, press the **ENTER** key. A blinking question mark (?) appears.

```
Interface
? Parallel
```

- 4 Press the Δ or ∇ key repeatedly until `Network` appears. Press the **ENTER** key.

```
Interface
? Network
```

- 5 Press the \triangleright key and then press the Δ or ∇ key repeatedly until the display shows `>Network Status Page Off`.

```
>Network Status
Page Off
```

- 6 The default setting is `Off`. If it is set to `On`, press the **ENTER** key. A blinking question mark (?) appears.

```
>Network Status
Page ? Off
```

- 7 Press the Δ or ∇ key to select `On`.

```
>Network Status
Page ? On
```

- 8 Press the **ENTER** key again.
- 9 Press the **MENU** key. The display returns to Ready. The printer prints a network status page as an example shown in *Figure 3-7* below.

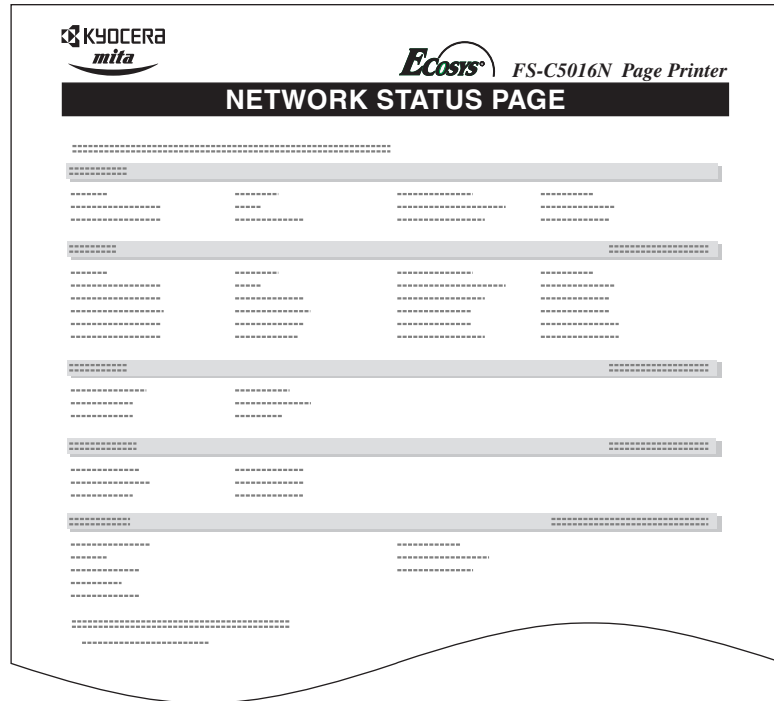

Figure 3-7

3.6 Making Default Settings

Using the operator panel, you can set the default for the following items. Note default settings made using the operator panel may be overridden by the printer driver settings and application software.

3.6.1 Default Emulation

You can change the emulation mode and character code set for the current interface. The printer is capable of the following emulation modes:

- HP PCL 6 (HP Color LaserJet 8550)
- KPDL3 (PostScript 3)

The printer can automatically switch between HP PCL 6 and KPDL3 depending on the print job that is received from the computer. To do this, select `KPDL (AUTO)` in the following procedure.

- 1** Press the **MENU** key.
- 2** Press the Δ or ∇ key repeatedly until `Emulation >` appears on the message display. One of the emulation modes appears, indicating the emulation currently in use.

```
PCL 6 (default)
KPDL
KPDL (AUTO)
```

- 3** To change the default emulation, press the **ENTER** key. A blinking question mark (?) appears.

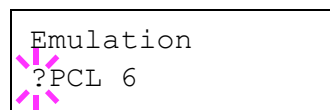

```
Emulation
?PCL 6
```

- 4** Press the Δ or ∇ key repeatedly until the desired emulation mode is displayed.
- 5** Press the **ENTER** key.
- 6** Press the **MENU** key. The display returns to `Ready`.

3.6.2 Alternative Emulation for KPDL Emulation

The auto KPDL [KPDL (AUTO)] emulation enables the printer to automatically change the emulation mode according to the print job received. The emulation mode the printer switches alternatively can be selected using the operator panel. The default alternative emulation is HP PCL 6.

- 1** Press the **MENU** key.
- 2** Press the Δ or ∇ key repeatedly until `Emulation >` appears.

```
Emulation >
PCL 6
```

- 3** Press the **ENTER** key. A blinking question mark (?) appears.

```
Emulation
?PCL 6
```

- 4** Press the Δ or ∇ key repeatedly until `KPDL (AUTO)` appears. Press the **ENTER** key.

```
Emulation
?KPDL (AUTO)
```

- 5** Press the \triangleright key. Press the Δ or ∇ key until `>Alt. Emulation` is displayed. The alternative emulation currently selected also appears — `PCL 6` or `KC-GL`.

- 6** To change the alternative emulation, press the **ENTER** key. A blinking question mark (?) appears.

```
>Alt. Emulation
?PCL 6
```

- 7** Press the Δ or ∇ key until the desired alternative emulation appears.
- 8** Press the **ENTER** key.
- 9** Press the **MENU** key. The display returns to `Ready`.

3.6.3 Printing KPDL Errors

The printer can print error descriptions when printing error occurs during KPDL emulation. The default is `Off` — the printer does not print KPDL errors.

- 1 Press the **MENU** key.
- 2 Press the Δ or ∇ key repeatedly until `Emulation >` appears.

```
Emulation >
PCL 6
```

- 3 Press the **ENTER** key. A blinking question mark (?) appears.

```
Emulation
?PCL 6
```

- 4 Select `KPDL` or `KPDL (AUTO)` using the Δ or ∇ key.

```
Emulation
?KPDL
```

- 5 Press the **ENTER** key.
- 6 Press the \triangleright key. Press the Δ or ∇ key until `>Print KPDL Errs (errors)` appears.

```
>Print KPDL Errs
Off
```

- 7 Press the **ENTER** key. A blinking question mark (?) appears.

- 8 Select `On` using the Δ or ∇ key. Press the **ENTER** key.

```
>Print KPDL Errs
? On
```

- 9 Press the **MENU** key. The display returns to `Ready`.

3.6.4 Default Font

You can select the default font for the current interface. The default font can be one of the internal fonts or a font that is downloaded to the printer memory or stored on memory card or hard disk.

In this menu, you can also set the type and pitch for Courier and Letter Gothic; as well as to print a font list.

- 1** Press the **MENU** key.
- 2** Press the Δ or ∇ key repeatedly until `Font >` appears.

```
Font >
```

- 3** Press the \triangleright key. Press the Δ or ∇ key until `>Font Select >` appears.

```
>Font Select >
Internal
```

- 4** To select an internal font, make sure that `Internal` is displayed and press the \triangleright key. The display changes as shown below. If `Internal` is not displayed, press the **ENTER** key, then press the Δ or ∇ key until it appears.

```
>> I000
```

To select an optional font, press the **ENTER** key while `>Font Select >` is displayed. Press the Δ or ∇ key repeatedly until `Option` appears and then press the **ENTER** key. Press the \triangleright key next to display the font selection shown above. You can perform this operation only when optional fonts are installed in the printer.

The letter before the number indicates the location of the font, as shown below:

I	Internal font
S	Soft (downloaded) font
M	Fonts in optional memory card
H	Fonts in RAM disk or optional hard disk
O	Fonts in optional ROM (API)

- 5** Press the **ENTER** key. A blinking question mark (?) appears.

```
>>?I000
```

- 6** Press the Δ or ∇ key repeatedly until the desired font number appears. For font numbers of the internal fonts, see [Printing Lists of Fonts on page 3-50](#).
- 7** When the desired font is displayed, press the **ENTER** key.
- 8** Press the **MENU** key. The display returns to `Ready`.

Selecting Regular or Dark Courier/Letter Gothic

Courier or Letter Gothic font thickness can be selected as Regular or Dark. In the procedure below, it is assumed that Courier is selected. The procedure is the same for Letter Gothic.

1 Press the **MENU** key.

2 Press the Δ or ∇ key repeatedly until `Font >` appears.

```
Font >
```

3 Press the \triangleright key. Press the Δ or ∇ key until `>Font Select >` appears.

```
>Font Select >
Internal
```

4 Make sure that `Internal` is displayed and press the \triangleright key.

5 Press the Δ or ∇ key repeatedly until `>>Courier` appears. If you are selecting the thickness of the Letter Gothic font, choose `>> Letter Gothic` here instead.

```
>>Courier
Regular
```

6 Press the **ENTER** key. A blinking question mark (?) appears.

```
>>Courier
? Regular
```

7 Select `Regular` or `Dark` using the Δ or ∇ key.

8 Press the **ENTER** key.

9 Press the **MENU** key. The display returns to `Ready`.

Changing the Default Font Size

You can change the size of the default font. If you selected a proportional font, the character size can also be changed.

- 1** Press the **MENU** key.
- 2** Press the Δ or ∇ key repeatedly until `Font >` appears.

```
Font >
```

- 3** Press the \triangleright key. Press the Δ or ∇ key until `>Font Select >` appears.

```
>Font Select >
Internal
```

- 4** Make sure that `Internal` is displayed and press the \triangleright key.

- 5** Press the Δ or ∇ key repeatedly until `>>Size` appears.

```
>>Size
012.00 point(s)
```

- 6** Press the **ENTER** key. A blinking cursor () appears.

```
>>Size
012.00 point(s)
```

- 7** Press the Δ or ∇ key to increase or decrease the value at the blinking cursor. The font size can be set between 4 and 999.75 points, in 0.25-point increments. Use the \triangleright or \triangleleft key to move the cursor right and left.

- 8** When the desired size is displayed, press the **ENTER** key.

- 9** Press the **MENU** key. The display returns to `Ready`.

Character Pitch for Courier/Letter Gothic

You can set the character pitch for fixed fonts when the default font is Courier or Letter Gothic.

1 Press **MENU** key.

2 Press the Δ or ∇ key repeatedly until `Font >` appears.

```
Font >
```

3 Press the \triangleright key. Press the Δ or ∇ key until `>Font Select >` appears.

```
>Font Select >
Internal
```

4 Make sure that `Internal` is displayed and press the \triangleright key.

5 Press the Δ or ∇ key repeatedly until `>>Pitch` appears.

```
>>Pitch
10.00 cpi
```

6 Press the **ENTER** key. A blinking cursor () appears.

```
>>Pitch
10.00 cpi
```

7 Press the Δ or ∇ key to increase or decrease the value at the blinking cursor. The character pitch can be set between 0.44 and 99.99 characters per inch, in 0.01 character-per-inch increments. Use the \triangleright or \triangleleft key to move the cursor right and left.

8 When the desired size is displayed, press the **ENTER** key.

9 Press the **MENU** key. The display returns to `Ready`.

Setting the Code Set

You can change the character code set. Available character code sets vary depending on the current font. (The default is IBM PC-8.)

1 Press the **MENU** key.

2 Press the Δ or ∇ key repeatedly until `Font >` appears.

```
Font >
```

3 Press the \triangleright key.

4 Press the Δ or ∇ key repeatedly until `>Code Set` appears.

```
>Code Set  
IBM PC-8
```

5 Press the **ENTER** key. A blinking question mark (?) appears.

```
>Code Set  
?IBM PC-8
```

6 Press the Δ or ∇ key until the desired character code set appears.

7 Press the **ENTER** key.

8 Press the **MENU** key. The display returns to `Ready`.

Printing Lists of Fonts

To help you decide in selecting a font, you can printout lists of the internal fonts or the optional fonts including downloaded fonts. Samples for font lists are shown in *Figure 3-8 on page 3-51*.

1 Press the **MENU** key.

2 Press the Δ or ∇ key repeatedly until `Font >` appears.

```
Font >
```

3 Press the \triangleright key.

4 Press the Δ or ∇ key repeatedly until `>List of Internal Fonts` or `>List of Option Fonts` appears.

```
>List of  
Internal Fonts
```

5 Press the **ENTER** key. A question mark (?) appears.

```
>List of  
Internal Fonts?
```

6 Press the **ENTER** key again. Processing appears, then Ready. The printer prints out a list of fonts with a sample and font ID (number) for each of them. Sample lists of fonts are shown in *Figure 3-8* on the next page.

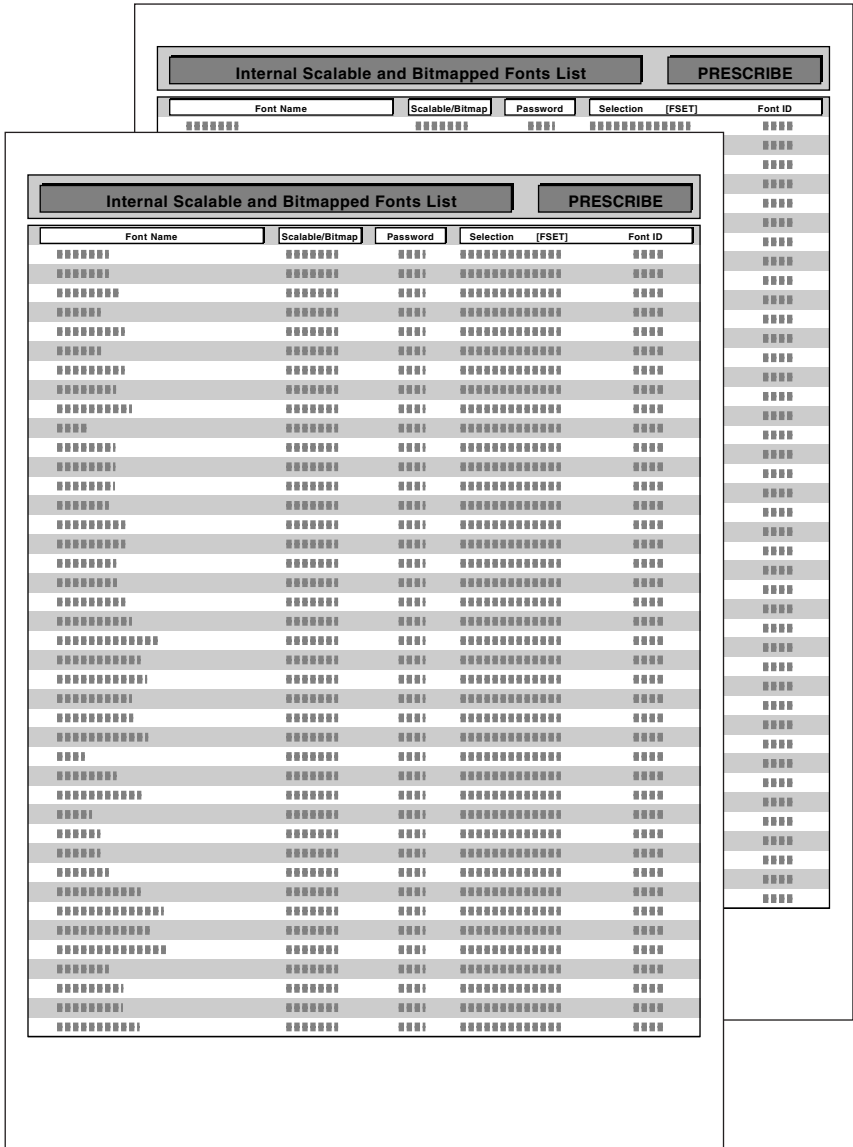

Figure 3-8

3.7 Pagination

In Page Set menus, you can set the number of copies, page orientation, and other settings regarding pagination.

3.7.1 Number of Copies

You can set the number of copies of each page to be printed for the current interface. The number of copies can be set between 1 and 999.

- 1** Press the **MENU** key.
- 2** Press the Δ or ∇ key repeatedly until Page Set > appears.

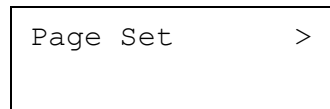

Page Set >

- 3** Press the \triangleright key.
- 4** Press the Δ or ∇ key repeatedly until >Copies appears.



>Copies 001

- 5** Press the **ENTER** key. A blinking cursor () appears.

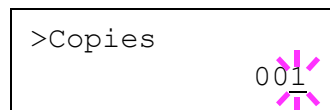

>Copies 001

- 6** Press the Δ or ∇ key to increase or decrease, respectively, the value at the blinking cursor. Use the \triangleright and \triangleleft keys to move the cursor right and left.
- 7** When the desired size is displayed, press the **ENTER** key.
- 8** Press the **MENU** key. The display returns to Ready.

3.7.2 Print Orientation

You can select portrait (upright) or landscape (sideways) page orientation.

Portrait Orientation

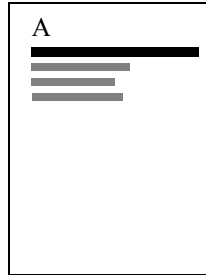

Landscape Orientation

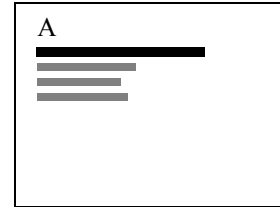

Figure 3-9

- 1** Press the **MENU** key.
- 2** Press the Δ or ∇ key repeatedly until Page Set > appears.

Page Set >
- 3** Press the \triangleright key.
- 4** Press the Δ or ∇ key repeatedly until >Orientation appears.

>Orientation
Portrait
- 5** Press the **ENTER** key. A blinking question mark (?) appears.

>Orientation
? Portrait
- 6** Select Portrait or Landscape using the Δ or ∇ key.
- 7** Press the **ENTER** key.
- 8** Press the **MENU** key. The display returns to Ready.

3.7.3 Page Protect Mode

The Page Protect Menu does not normally appear, however, Page Protect will be forcibly set to On if a print overrun error occurs because the print job is too complex. When this has happened, be sure to reset Page Protect to Auto (default) in order to maintain the optimum use of printer memory.

- 1** Press the **MENU** key.
- 2** Press the Δ or ∇ key repeatedly until Page set > appears.

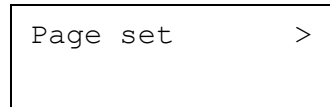

Page set >

- 3** Press the \triangleright key.
- 4** Press the Δ or ∇ key repeatedly until >Page Protect appears.

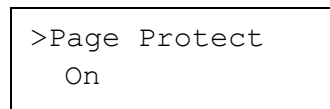

>Page Protect
On

- 5** Press the **ENTER** key. A blinking question mark (?) appears.

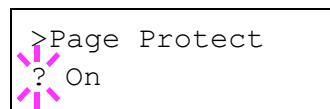

>Page Protect
? On

- 6** Press the Δ or ∇ key repeatedly until Auto appears.

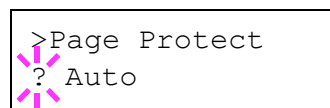

>Page Protect
? Auto

- 7** Press the **ENTER** key.
- 8** Press the **MENU** key. The display returns to Ready.

3.7.4 Linefeed (LF) Action

This procedure instructs the printer what to do when it receives a linefeed code (0AH).

- LF only: Linefeed is performed (Default).
- CR and LF: A linefeed and carriage return are performed.
- Ignore LF: The linefeed is ignored.

1 Press the **MENU** key.

2 Press the Δ or ∇ key repeatedly until Page Set > appears.

```
Page Set      >
```

3 Press the \triangleright key.

4 Press the Δ or ∇ key repeatedly until >LF Action appears.

```
>LF Action
  LF only
```

5 Press the **ENTER** key. A blinking question mark (?) appears.

```
>LF Action
? LF only
```

6 Press the Δ or ∇ key repeatedly until the desired linefeed action appears.

7 When the desired action is displayed, press the **ENTER** key.

8 Press the **MENU** key. The display returns to Ready.

3.7.5 Carriage-Return (CR) Action

This procedure instructs the printer what to do when it receives a carriage-return code (ODH).

- CR only: A carriage-return is performed (Default).
- CR and LF: A linefeed and carriage return are performed.
- Ignore CR: The carriage-return is ignored.

1 Press the **MENU** key.

2 Press the Δ or ∇ key repeatedly until Page Set > appears.

```
Page Set >
```

3 Press the \triangleright key.

4 Press the Δ or ∇ key repeatedly until >CR Action appears.

```
>CR Action  
CR only
```

5 Press the **ENTER** key. A blinking question mark (?) appears.

```
>CR Action  
? CR only
```

6 Press the Δ or ∇ key repeatedly until the desired carriage-return action appears.

7 When the desired action is displayed, press the **ENTER** key.

8 Press the **MENU** key. The display returns to Ready.

3.7.6 Wide A4 Pitch

Turn this to On to increase the maximum number of characters that can be printed in a line for A4 page (78 characters at 10 pitch) and Letter size page (80 characters at 10 pitch). This setting is effective in only PCL 6 emulation.

- 1** Press the **MENU** key.
- 2** Press the Δ or ∇ key repeatedly until `Page set >` appears.

```
Page Set      >
```

- 3** Press the \triangleright key.
- 4** Press the Δ or ∇ key repeatedly until `>Wide A4` appears.

```
>Wide A4  
Off
```

- 5** Press the **ENTER** key. A blinking question mark (?) appears.

```
>Wide A4  
? Off
```

- 6** Select On or Off using the Δ or ∇ key.
- 7** Press the **ENTER** key.
- 8** Press the **MENU** key. The display returns to Ready.

3.8 Setting Print Quality

The printer features the Print Quality menu which lets you select the intensity of the gloss mode (Low or High).

3.8.1 Gloss Mode

The gloss mode, when set to High, increases the effect of glossiness in printing by reducing the printing speed by half. The gloss mode is not available when Transparency is selected as the paper type setting.



Note

Depending on the paper used, printing in gloss mode may cause wrinkle in paper. To reduce wrinkle, try using thicker paper.

The default gloss mode is Low. To confirm or change the gloss mode, proceed as follows:

- 1 Press the **MENU** key.
- 2 Press the Δ or ∇ key repeatedly until Print Quality > appears.

```
Print Quality >
```

- 3 Press the \triangleright key.
- 4 Press the Δ or ∇ key repeatedly until >Gloss Mode appears.

```
>Gloss Mode  
Low
```

- 5 To change the gloss mode, press the **ENTER** key. A blinking question mark (?) appears.

```
>Gloss Mode  
? Low
```

- 6 Press the Δ or ∇ key to change from Low to High.
- 7 Press the **ENTER** key to finalize the selection.
- 8 Press the **MENU** key. The display returns to Ready.

3.9 Operating the Storage Device

The printer supports three types of storage device; memory card, optional hard disk, and RAM disk. The memory card and optional hard disk are installed into the dedicated slots of the printer. The RAM disk is an allocated part of the printer's memory. If the optional hard disk is installed in the printer, the e-MPS function will be available. For details, see *e-MPS on page 3-20*.

The basic operations of each storage device are the same. This section mainly explains the operation of the memory card.

3.9.1 Using the Memory Card

The printer is equipped with a slot for a memory card. By inserting a memory card into the printer, the following operations become available.

- Reading Font Data
- Reading Data
- Writing Data
- Deleting Data
- Formatting Memory Card
- Printing a List of Data Names

For details about the handling of the memory card, see *Appendix A Options, section A.3.1 Memory Card on page A-7*.

Reading Font Data

In case of a memory card if a memory with the font data card is already inserted into the slot when the printer is turned on, the fonts are automatically read into the printer. To read fonts into the printer from a memory card, proceed as follows.

- 1** Press the **MENU** key.
- 2** Press the Δ or ∇ key repeatedly until `Memory Card >` appears.

```
Memory Card >
```

- 3** Press the \triangleright key.
- 4** Press the Δ or ∇ key repeatedly until `>Read Fonts` appears.

```
>Read Fonts
```

- 5** Press the **ENTER** key. A question mark (?) appears.

```
>Read Fonts ?
```

- 6 Press the **ENTER** key. Processing appears and the reading of data from the memory card starts. When completed, Processing disappears.

```
>Read Fonts
Processing
```

- 7 Press the **MENU** key. The display returns to Ready.

Reading Data

You can print out the data in the memory card. To read the data saved on the memory card and print it out, proceed as follows.

- 1 Press the **MENU** key.
- 2 Press the Δ or ∇ key repeatedly until Memory Card > appears.

```
Memory Card >
```

- 3 Press the \triangleright key.
- 4 Press the Δ or ∇ key repeatedly until >Read Data appears (Report, in this example).

```
>Read Data
Report
```

- 5 Press the **ENTER** key. A blinking question mark (?) appears before the data name.

```
>Read Data
?Report
```

- 6 Press the Δ or ∇ key to display the desired data name.
- 7 Press the **ENTER** key. Processing appears and the reading of data from the memory card starts.

Writing Data

Data can be written to a memory card until no space is left for storing. When writing to a memory card, a name is assigned to the file automatically. You can use the procedure explained in the section *Printing a List of Data Names (Partitions) on page 3-64* to print a list of data names for confirmation.

To write data to a memory card, proceed as follows.



Note

First check that the memory card is properly formatted. Otherwise, the >Write Data message to be explained below will not be shown on the message display. If the memory card inserted in the memory card slot is not formatted, the >Format will automatically appear on the message display. Format the memory card. See *Formatting a Memory Card on page 3-63*.

- 1** Press the **MENU** key.
- 2** Press the Δ or ∇ key repeatedly until `Memory Card >` appears.

```
Memory Card >
```

- 3** Press the \triangleright key.
- 4** Press the Δ or ∇ key repeatedly until `>Write Data` appears.

```
>Write Data
```

- 5** Press the **ENTER** key. A question mark (?) appears.

```
>Write Data ?
```

- 6** Press the **ENTER** key. `Processing` appears, then `Waiting`.

- 7** In this state, send the file from the computer to the printer.

As the printer receives data, the message display changes to `Processing`, then when the end of the data is received, the message display changes to `Waiting`.

- 8** Check that the message display has changed to `Waiting`, then press the **GO** key. This writes the file to the memory card and instructs the printer to automatically print out a memory card write information page as shown below.

The file is written onto the memory card given a destination name (also referred to as a partition name) which the printer automatically assigns one after another as follows: DataS001 (first data), DataS002 (second data), DataS003 (third data)...

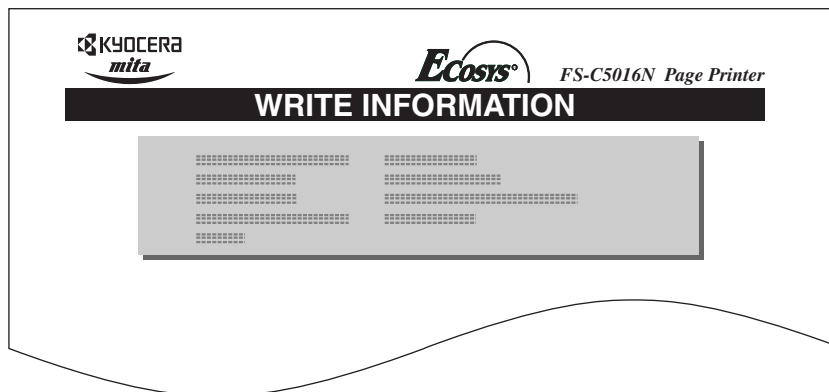

Figure 3-10

Partition Type:	Type of data written (currently only type 2 is supported).
Partition Name:	The destination name of data written to the card.
Write Partition Length:	The size of the written data on the memory card.
Others:	Error information.

When the memory card write information page is printed, the display returns to Ready.

- 9 Repeat above steps until you have transferred all data (files) that you want to write to the memory card. Each time you finish writing data, a memory card write information page is printed from the printer showing the information, but pertaining only to the data just written. To see all data contained in the memory card at once, print a list of data names as explained. See [Printing a List of Data Names \(Partitions\) on page 3-64](#).

Deleting Data

It is possible to use the printer to delete data from a memory card one by one.

To delete data from a memory card, proceed as follows. Check that the memory card contains data. Otherwise, the >Delete Data menu will not appear on the message display.

- 1 Press the **MENU** key.
- 2 Press the Δ or ∇ key repeatedly until `Memory Card >` appears.

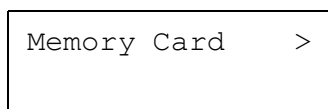

- 3 Press the \triangleright key.

- 4** Press the Δ or ∇ key repeatedly until `>Delete Data` appears. The data name also appears (`Report`, in this example).

```
>Delete Data
  Report
```

- 5** Press the **ENTER** key. A blinking question mark (?) appears before the data name.

```
>Delete Data
?Report
```

- 6** Press the Δ or ∇ key to display the desired data name.

- 7** Press the **ENTER** key. `Processing` appears and the data is deleted from the memory card. The display returns to `Ready`.

Formatting a Memory Card

A new memory card must be formatted before it can be used in the printer. Formatting allows data to be written to the memory card.



Note

- **Formatting will destroy any existing data on a storage device including a used memory card.**
- **Formatting of the memory card must be executed from the printer.**

To format a memory card, proceed as follows. When a new memory card is inserted in the printer's slot, `Format error Memory card` will appear on the message display.

- 1** Press the **MENU** key.
- 2** Press the Δ or ∇ key repeatedly until `Memory Card >` appears.

```
Memory Card >
```

- 3** Press the \triangleright key.
- 4** Press the Δ or ∇ key repeatedly until `>Format` appears.

```
>Format
```

- 5** Press the **ENTER** key. A question mark (?) appears.

```
>Format ?
```

- 6 Press the **ENTER** key. Processing appears and formatting of the memory card starts.

When the formatting is successfully completed, the printer automatically prints out a format information page, which allows you to check the memory card for proper formatting.

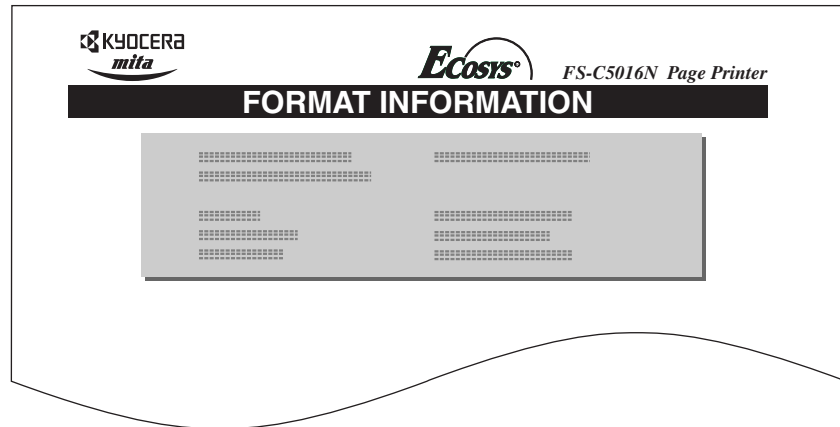

Figure 3-11

Format information page includes the following items:

- Capacity:** The total size of the memory card.
- Used Space:** The size the printer uses for its system.
- Free Space:** The size remaining in the memory card for storing data.

When the memory card format information is printed, the display returns to Ready.

Printing a List of Data Names (Partitions)

The printer prints a list of all data names (referred to as partitions) stored in a memory card for reference. (Printing a list is also available for a font card.)

To print a list of data names for the memory card, proceed as follows.

- 1 Press the **MENU** key.
- 2 Press the Δ or ∇ key repeatedly until Memory Card > appears.

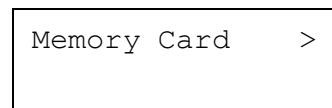

- 3 Press the \triangleright key.
- 4 Press the Δ or ∇ key repeatedly until >List of Partitions appears.

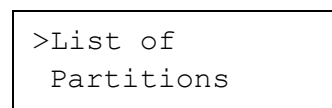

- 5** Press the **ENTER** key. A question mark (?) appears.

```
>List of
Partitions ?
```

- 6** Press the **ENTER** key. Processing appears and the printing of the list starts.

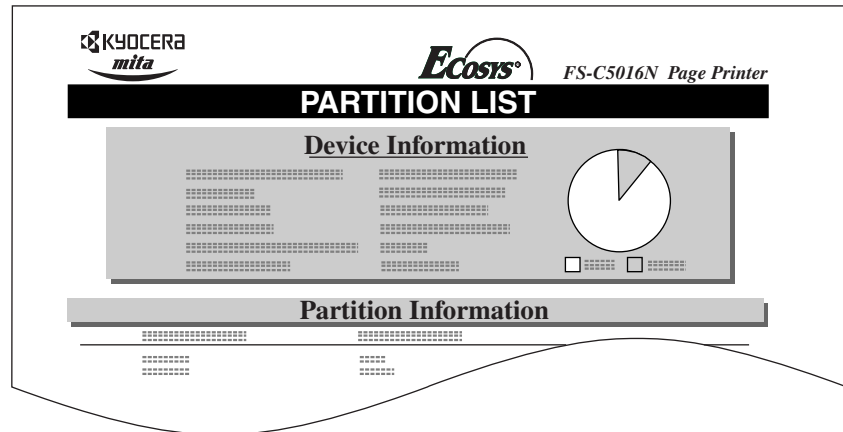

Figure 3-12

The printout (example above) includes the following information:

Device Name/Number:	MEMORY CARD/A is indicated for the memory card.
Capacity:	The total capacity of the memory card in bytes.
Used Space:	The total size of the data stored in the memory card in bytes.
Free Space:	The size of the capacity remaining in the memory card for storing further data, including the amount of memory that the printer uses for its system.
Partition Name:	The name of the written data assigned automatically by the printer.
Partition Size:	The size of the written data in bytes.
Partition Type:	The type of the written data i.e., whether it is host data (Data) or font data (Font).

When the list of file names (partition list) for the memory card is printed, the display returns to Ready.

3.9.2 Using the Optional Hard Disk

Installing the optional hard disk into the printer allows you to perform the following operations on the hard disk.

- Reading data
- Writing data
- Deleting data
- Formatting hard disk
- Printing a list of data names (partitions)

When an optional hard disk is inserted into the printer for the first time, it must be formatted before use. If the optional hard disk is not formatted, the >FORMAT menu will automatically appear on the message display.

The operations of the optional hard disk are the same as those of the memory card. See the relevant sections in [section 3.9.1 Using the Memory Card on page 3-59](#).

When data is written to the hard disk, the name automatically given to the corresponding file will be DataH001 (for the 1st file), DataH002 (for the 2nd file), DataH003 (for the 3rd file), etc.

3.9.3 Using the RAM Disk

The RAM disk is a memory space shared within the printer memory that can temporarily store print jobs. The RAM disk can be used only for electronic sorting. The stored print job can then be used to print multiple copies of the job reducing the total amount of time required to print the whole job. It acts similar to the hard disk except that the data is effective only during the printer is powered up. By default, the RAM disk is not activated (Off).

To use the RAM disk, activate and enter the desired size of the RAM disk in the manner described below. The maximum RAM disk size can be calculated as follows:

Maximum RAM disk size = Total printer memory -36 MB

For example, if the total memory installed in your printer is 256 MB, you can set 224 MB of RAM disk. If you attempt to set the RAM disk size beyond this restriction, the printer automatically round it down so that the size is always 36 MB less than the total printer memory. Once the RAM disk size is set, the printer must be reset.

To activate RAM disk in the printer's memory, first you must set the RAM disk mode to On and set the desired data size for the RAM disk as described in the following section. This allows you to perform the following operations on the RAM disk.

- Reading data
- Writing data
- Deleting data
- Printing a list of data names (partitions)

The operations of the RAM disk are the same as those of the memory card. See the relevant sections in [section 3.9.1 Using the Memory Card on page 3-59](#). When data is written to the RAM disk, the name automatically given to the corresponding file will be DataH001 (for the 1st file), DataH002 (for the 2nd file), DataH003 (for the 3rd file), etc.



- The RAM disk can not be used when an optional hard disk is installed.
- The RAM disk stores data only temporarily. When the printer is reset or turned off, the stored data will be erased.
- The RAM disk is allocated within the printer's memory available to users. If the size of the RAM disk is set too large, the printing speed may decrease or the memory may become insufficient.

To confirm the RAM disk size or activate the RAM disk, proceed as follows:

Setting the RAM Disk Size

- 1 Press the **MENU** key.
- 2 Press the Δ or ∇ key repeatedly until RAM Disk Mode appears.

```
RAM Disk Mode
  Off
```

- 3 Press the **ENTER** key. A blinking question mark (?) appears. Press the Δ or ∇ key to select On. Press the **ENTER** key.

```
RAM Disk Mode
? On
```

- 4 Press the \triangleright key. Press the Δ or ∇ key repeatedly until >RAM Disk Size appears. The data size also appears.

```
>RAM Disk Size
  0119 MByte
```

- 5 Press the **ENTER** key. A blinking cursor () appears. Press the Δ or ∇ key to display the desired size. Definable RAM disk size is 0001 to 1024.

```
>RAM Disk Size
  0119 MByte
```

This range varies depending on the total memory size of the printer. The setting exceeding this range is automatically adjusted to the maximum RAM disk size.

- 6 When the desired RAM disk size is displayed, press the **ENTER** key.
- 7 Press the **MENU** key. The display returns to Ready. Then, turn off the printer and on again. The selected RAM disk size is activated after the printer is restarted.

3.10 Paper Handling

This section explains how to change mode for the MP (multi-purpose) tray, the paper size and type for each paper source, and how to select the paper source and paper destinations.

3.10.1 MP Tray Mode

The MP tray can be used in either of two modes — *Cassette* or *First*. The MP tray feed paper differently depending on the mode:

- **Cassette Mode (default)**
The MP tray acts in the same manner as other paper source. The printer can correctly feed paper from any paper source as you command on the printer driver. The cassette mode provides a faster printing speed than the first mode.
- **First Mode**
The MP tray automatically feeds paper placed on the MP tray overriding another paper source that is selected on the printer driver. After all paper sheets in the MP tray have been used up (approximately 100 sheets [A4 size, 0.11 mm thickness]), paper will be fed from the paper source originally selected. This mode is convenient to feed paper of special size or type without reloading the current paper source. However, the MP tray must be kept empty if you desire to feed paper from the intended paper source.

To switch the MP tray to *First* mode, proceed as follows:

- 1** Press the **MENU** key.
- 2** Press the Δ or ∇ key repeatedly until `Paper Handling >` appears.

```
Paper Handling >
```

- 3** Press the \triangleright key.
- 4** Press the Δ or ∇ key repeatedly until `>MP Tray Mode` appears.

```
>MP Tray Mode  
Cassette
```

- 5** Press the **ENTER** key. A blinking question mark (?) appears.

```
>MP Tray Mode  
? Cassette
```

- 6** Press the Δ or ∇ key to change *Cassette* to *First*.
- 7** Press the **ENTER** key. The MP tray mode is changed.
- 8** To exit the menu selection, press the **MENU** key.

3.10.2 Setting MP Tray Paper Size

When you use the MP tray in cassette mode, you should set the MP tray size to the paper size that is used to format the job to print. If the sizes do not match, printing will not be performed on the correct size paper. The default setting is `Letter` size for the U.S. and Canada and `A4` for other countries.

For more information about the paper sizes that you can feed from the MP tray, see [Chapter 2 Handling Paper](#).



Note

Feeding the paper having a paper size which does not match the current paper size from the MP tray can cause paper jam.

- 1** Press the **MENU** key.
- 2** Press the Δ or ∇ key repeatedly until `Paper Handling >` appears.

```
Paper Handling >
```

- 3** Press the \triangleright key.
- 4** Press the Δ or ∇ key repeatedly until `>MP Tray Size` appears. In this example, the current MP tray paper size is `A4`.

```
>MP Tray Size  
A4
```

- 5** To change the paper size, press the **ENTER** key. A blinking question mark (?) appears.

- 6** Press the Δ or ∇ key to display the desired paper size. The message display toggles through the following paper sizes:

A4
Executive
Letter
Legal
Custom
Oficio II
Statement
Folio
Youkei 2
Youkei 4
16K
Hagaki
Oufukuhagaki
Monarch
Business
Comm. #9
Comm. #6 3/4
DL
C5
A6
B6
A5
B5
ISO B5

- 7** When the desired paper size is displayed, press the **ENTER** key. The paper size is set for the MP tray.

- 8** To exit the menu selection, press the **MENU** key.

3.10.3 Setting the MP Tray Paper Type

By setting a paper type (plain, recycled, etc.) to the MP tray, you can select the paper on the MP tray according to the paper type you command on the printer driver. The default setting is plain paper.

For more information about paper types that can be fed from the MP tray, see [Chapter 2 Handling Paper](#).

- 1** Press the **MENU** key.
- 2** Press the Δ or ∇ key repeatedly until Paper Handling > appears.

```
Paper Handling >
```

- 3** Press the \triangleright key.
- 4** Press the Δ or ∇ key repeatedly until >MP Tray Type appears.

```
>MP Tray Type
Plain
```

- 5** To change paper type, press the **ENTER** key. A blinking question mark (?) appears.

```
>MP Tray Type
? Plain
```

- 6** Press the Δ or ∇ key to display the desired paper type. The message display toggles through the following paper types:

```
Plain
Transparency
Preprinted
Labels
Bond
Recycled
Vellum
Rough
Letterhead
Color
Prepunched
Envelope
Cardstock
Coated
Thick
High quality
Custom 1(to 8)
```

- 7** When the desired paper type is displayed, press the **ENTER** key. The paper type is set to the MP tray.
- 8** To exit the menu selection, press the **MENU** key.

3.10.4 Setting the Cassette Paper Size

To set the standard sizes A5, A4, B5, Letter, and Legal size for the paper cassette, use the following procedure to set the paper size dial of the paper cassette.

If you use a non-standard size, see [Custom Paper Size](#).

Properly set the paper into the paper cassette. For details about the adjustment of the paper guides and paper stopper inside the paper cassette, see [Chapter 2 Handling Paper, section 2.3 Loading Paper on page 2-8](#).

- 1 Turn the paper size dial so that the size of the paper you are going to use appears in the paper size window.

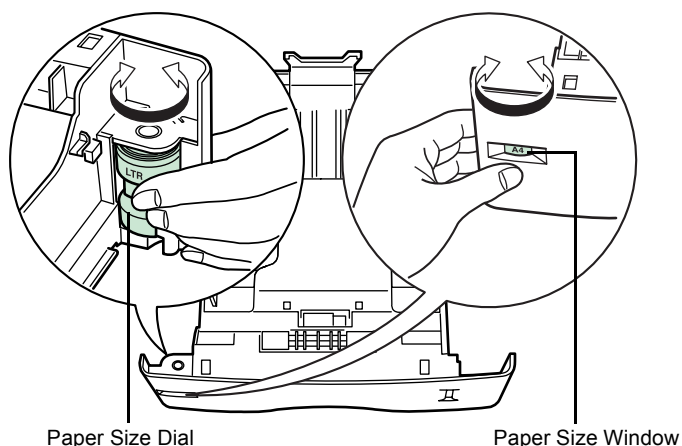

Figure 3-13

- 2 Adjust the paper guides and paper stopper inside the paper cassette to the size of the paper to be used and load the paper into the cassette.

The paper size setting for the paper cassette is completed.

Custom Paper Size

In addition to the standard sizes A5, A4, B5, Letter, and Legal size for the paper cassette, paper of other sizes can be fed. When placing paper of sizes other than A5, A4, B5, Letter, or Legal into the paper cassette, set the size of the paper to be used into the printer by following the procedure given below. If an optional paper feeder (PF-60) is installed, custom sizes for its paper cassette can be set using the same procedure.

This menu appears when the paper size dial of the paper cassette is set to **OTHER**.

Properly set the paper into the paper cassette. For details about the adjustment of the paper guides and paper stopper inside the paper cassette, see [Chapter 2 Handling Paper, section 2.3 Loading Paper on page 2-8](#).

Setting Paper Size Dial

Use the following procedure to set the paper size dial to **OTHER**.

- 1** Pull out the paper cassette from the printer and turn the paper size dial to **OTHER**. See *step 1* in *Setting the Cassette Paper Size*.
- 2** Adjust the paper guides and paper stopper inside the paper cassette to the size of the paper to be used and load the paper into the cassette.

When using non-standard size paper, read the next section to set the paper size from the operator panel.

Setting a custom size from the Operator Panel

Set the size of the paper loaded in the paper cassette into the printer from the printer operator panel.

- 1** Press the **MENU** key.
- 2** Press the Δ or ∇ key repeatedly until `Paper Handling >` appears.

```
Paper Handling >
```

- 3** Press the \triangleright key.
- 4** Press the Δ or ∇ key repeatedly until `>Cassette Size >` appears.

If optional paper feeders are added, `Cassette 1 Size` will appear for the standard paper cassette and `Cassette 2 Size`, `Cassette 3 Size`, and `Cassette 4 Size` will appear for the optional paper feeders.

```
>Cassette Size >
Custom
```

- 5** Press the **ENTER** key. A blinking question mark (?) appears.

```
>Cassette Size
? Custom
```

- 6 Press the Δ or ∇ key to display the desired paper size. The message display toggles through the following paper sizes:

```
Custom  
Oficio II  
Folio  
16K  
C5  
A5  
B5  
ISO B5  
A4  
Executive  
Letter
```

- 7 When the desired paper size is displayed, press the **ENTER** key. The paper size is set for the paper cassette.

If you selected `Custom` in step 6, be sure to set the unit of measurement and the dimensions of the paper as described in the following sections.

Selecting the Unit of Measurement

Then, use the following procedure to set the unit of measurement.

- 1 Press the \triangleright key.
- 2 Press the Δ or ∇ key repeatedly until `>>Unit` appears. The unit of measurement can be selected between millimeters and inches. The current unit of measurement is displayed (the default setting is mm).

```
>>Unit  
mm
```

- 3 Press the **ENTER** key. A blinking question mark (?) appears.

```
>>Unit  
? mm
```

- 4 Select `mm` or `inch` using the Δ or ∇ key.
- 5 Press the **ENTER** key.
Set the dimensions of the paper as described in the next section.

Entering the Width and Length

Then, use the following procedure to set the paper size.

Enter the paper size for X Dimension and Y Dimension as shown in the figure.

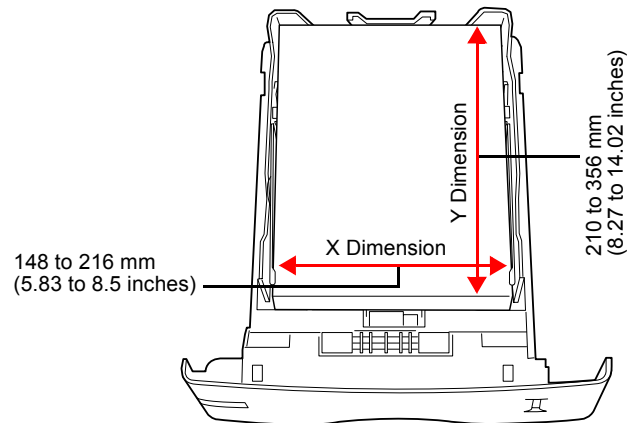

Figure 3-14

- 1** When the unit of measurement is set, press the ∇ key. >>X Dimension appears as shown below (the paper width setting).

```
>>X Dimension
      216 mm
```

- 2** Press the **ENTER** key. A blinking cursor ($_$) appears.

```
>>X Dimension
      21 $\_$ 6 mm
```

- 3** Press the Δ or ∇ key to increase or decrease the value of the figure where the cursor is blinking and display the desired width. The width can be set between 148 and 216 mm (5.83 to 8.5 inches). You can use the \triangleleft or \triangleright key to move the cursor right and left.
- 4** Display the paper width and press the **ENTER** key.
- 5** When the width is set, press the key. >>Y Dimension appears (the paper length setting). Set the desired length in the same way as the width. The length can be set between 210 and 356 mm (8.27 to 14.02 inches).
- 6** Display the paper length, press the **ENTER** key.
- 7** Press the **MENU** key. The display returns to Ready.
- 8** To print using the custom size set above, define the same custom size on the printer driver. For details, see [KX Printer Drivers Operation Guide](#).

3.10.5 Setting the Cassette Paper Type

By setting a paper type (plain, recycled, etc.) to the paper cassette, you can automatically select the paper in the paper cassette according to the paper type you command on the printer driver. The default setting is plain paper for all paper cassettes.

For more information about paper types that you can feed from the paper cassette, see [Chapter 2 Handling Paper](#).

- 1 Press the **MENU** key.
- 2 Press the Δ or ∇ key repeatedly until Paper Handling > appears.

```
Paper Handling >
```

- 3 Press the \triangleright key.
- 4 Press the Δ or ∇ key repeatedly until >Cassette Type appears.

If optional paper feeders are added, Cassette 1 Type will appear for the standard paper cassette and Cassette 2 Type, Cassette 3 Type, and Cassette 4 Type will appear for the optional paper feeders.

```
>Cassette Type  
Plain
```

- 5 To change paper type, press the **ENTER** key. A blinking question mark (?) appears.

```
>Cassette Type  
? Plain
```

- 6 Press the Δ or ∇ key to display the desired paper type. The message display toggles through the following paper types:

```
Plain  
Preprinted  
Bond  
Recycled  
Rough  
Letterhead  
Color  
Prepunched  
High quality  
Custom 1 (to 8)
```

- 7 When the desired cassette type is displayed, press the **ENTER** key.
- 8 To exit the menu selection, press the **MENU** key.

3.10.6 Selecting the Paper Feed Source

You can select the paper source using the operator panel, from which the printer feeds paper as the default. If an optional paper feeder(s) is installed, it is also available for the default paper source.

- 1** Press the **MENU** key.
- 2** Press the Δ or ∇ key repeatedly until Paper Handling > appears.

```
Paper Handling >
```

- 3** Press the \triangleright key.
- 4** Press the Δ or ∇ key repeatedly until >Feed Select appears.

```
>Feed Select
Cassette 1
```

- 5** To change the current paper feed source, press the **ENTER** key. A blinking question mark (?) appears.

```
>Feed Select
? Cassette 1
```

- 6** Press the Δ or ∇ key to display the desired paper feed source. The message display toggles through the following paper feed sources, depending on the installed optional paper feeders (from the top most paper cassette to the bottom paper cassette):

```
MP tray
Cassette 1
Cassette 2
Cassette 3
Cassette 4
```

Cassettes 2, 3 and 4 are available for selection when the optional paper feeders are installed.

- 7** When the desired paper source displayed, press the **ENTER** key.
- 8** To exit the menu selection, press the **MENU** key.

3.10.7 Duplex Printing

Using the optional duplexer (DU-300), you can automatically print on both sides of the paper. The duplexer is mounted underneath the printer.

Duplex printing is available for the following paper types:

Plain
Preprinted
Bond
Recycled
Rough
Letterhead
Color
Prepunched
High quality

Activating the duplexer on the operator panel is done by selecting either short edge or long edge binding mode.



Note

- To use this function, the optional duplexer must be installed on the printer.
- Duplex printing can be also performed from the MP tray. When the MP tray is set to First Mode (First), the paper size and paper type will be the same as those of the paper cassette currently set at the paper feed source. If the paper to be fed from the MP tray does not match the paper size and paper type of the current paper feed source cassette, a paper jam may occur.

Binding Modes

Binding refers to the manner in which printed pages of paper are joined together (by gluing, stitching, etc.) in book form. The two possible types of binding are: long-edge binding, in which pages are joined together along their long edge; and short-edge binding, in which they are joined together along their short edge. In selecting a binding type, you must also consider the orientation of the printed page. You can use long-edge or short-edge binding with either landscape or portrait printing.

Depending on the binding type and print orientation, the duplexer provides four types of binding. These are: (1) portrait, long-edge, (2) portrait, short edge, (3) landscape, long-edge, and (4) landscape, short-edge. The figure below shows these binding methods.

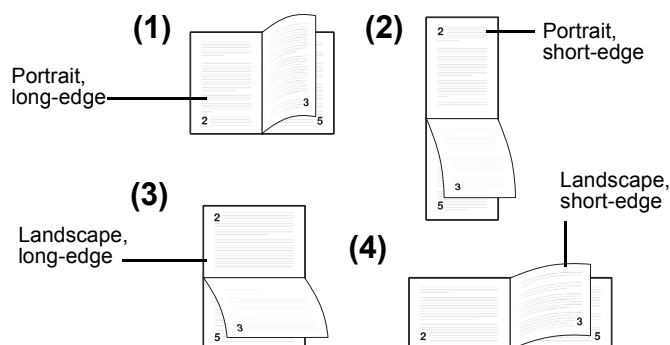

Figure 3-15

To select duplex printing and binding setup from the operator panel, proceed as follows. This procedure can only be performed when the optional duplexer (DU-300) is installed.

- 1** Press the **MENU** key.
- 2** Press the Δ or ∇ key repeatedly until Paper Handling > appears.

```
Paper Handling >
```

- 3** Press the \triangleright key.
- 4** Press the Δ or ∇ key repeatedly until >Duplex Mode appears.

```
>Duplex Mode
None
```

- 5** To activate duplex printing, press the **ENTER** key. A blinking question mark (?) appears.

```
>Duplex Mode
?None
```

- 6** Press the Δ or ∇ key to display the desired binding mode. The message display toggles through the following:

```
None (default)
Long edge bind
Short edge bind
```

- 7** When the desired binding mode is displayed, press the **ENTER** key. The binding mode is set.
- 8** To exit the menu selection, press the **MENU** key.

Note on Duplex Printing from the MP Tray

- You cannot select the MP tray, when it is set to 'cassette' mode, to perform duplex printing. To perform duplex printing, select a paper cassette.
- It is possible to duplex-print using the MP tray if it is set in 'first' mode. (See [Section 3.10.1 MP Tray Mode on page 3-68.](#)) However, be sure to set the MP tray paper size and paper type to the same paper size and paper type as those of the current paper cassette. If the paper size or type differs, a paper jam may occur.

3.10.8 Overriding Difference between A4 and Letter

When the `Override A4/LT` is turned on using the operator panel, the printer ignores the difference between A4 and Letter paper sizes. Printing is performed without an error message even if the actual paper size in the current cassette differs from the paper size formatting the job.

By default, this feature is off. To confirm and turn on the `Override A4/LT`, proceed as follows:

- 1** Press the **MENU** key.
- 2** Press the Δ or ∇ key repeatedly until `Paper Handling >` appears.

```
Paper Handling >
```

- 3** Press the \triangleright key.
- 4** Press the Δ or ∇ key repeatedly until `>Override A4/LT` appears.

```
>Override A4/LT  
Off
```

- 5** To change overriding mode, press the **ENTER** key. A blinking question mark (?) appears.

```
>Override A4/LT  
? Off
```

- 6** Press the Δ or ∇ key to change `Off` to `On`.
- 7** Press the **ENTER** key. The overriding mode is set.
- 8** To exit the menu selection, press the **MENU** key.

3.10.9 Creating Custom Paper Type

The following describes the procedure used to set a user-defined paper type for the printer. Eight custom user settings may be registered. After having been set, any of these may be called up when setting the paper type for a paper source.

The paper weight and duplex path can be set (see [Setting the Paper Weight on page 3-82](#), and [Setting the Duplex Path on page 3-83](#)) after selecting the paper type to be customized as follows. For how to reset the customized settings, see [section 3.10.10 Resetting the Custom Paper Type on page 3-84](#).

- 1** Press the **MENU** key.
- 2** Press the Δ or ∇ key repeatedly until Paper Handling > appears.

```
Paper Handling >
```

- 3** Press the \triangleright key.
- 4** Press the Δ or ∇ key repeatedly until >Type Adjust > appears.

```
>Type Adjust >
Custom 1
```

- 5** Press the **ENTER** key. A blinking question mark (?) appears.

```
>Type Adjust
? Custom 1
```

- 6** Press the Δ or ∇ key to display the desired paper type. The display changes as shown below.

```
Custom 1 (to 8)
Plain
Transparency
Preprinted
Labels
Bond
Recycled
Vellum
Rough
Letterhead
Color
Prepunched
Envelope
Cardstock
Coated
Thick
High quality
```

- 7** When the paper type to be customized is displayed, press the **ENTER** key.

- 8 Press the \triangleright key and proceed to *Setting the Paper Weight*.

Setting the Paper Weight

You can set the paper thickness for your custom paper type to be customized.

- 1 Display the custom paper type (see *section 3.10.9 Creating Custom Paper Type on page 3-81*) and press the \triangleright key.

- 2 Press the \triangle or ∇ key repeatedly until `>>Paper Weight` appears.

```
>>Paper Weight
Normal 1
```

- 3 Press the **ENTER** key. A blinking question mark (?) appears.

```
>>Paper Weight
? Normal 1
```

- 4 Press the \triangle or ∇ key to display the desired paper thickness. The display changes as shown below. For details of the default setting for each paper type, see *Chapter 2 Handling Paper, section 2.5 Paper Type on page 2-21*.

```
Light
Normal 1
Normal 2
Normal 3
Heavy 1
Heavy 2
Heavy 3
Extra Heavy
```

- 5 When the desired paper thickness displayed, press the **ENTER** key.

- 6 Press the **MENU** key. The display returns to Ready.

If the optional duplexer is installed on the printer, duplex printing can be enabled and disabled. See *Setting the Duplex Path* on the following page.

Setting the Duplex Path



Note

To use this function, the optional duplexer must be installed on the printer.

If the optional duplexer is installed on the printer, you can set whether or not to enable duplex printing as follows. The default setting is `Enable`.

1 Display the custom paper type (see [section 3.10.9 Creating Custom Paper Type on page 3-81](#)) and press the `▷` key.

2 Press the `△` or `▽` key repeatedly until `>>Duplex path` appears.

```
>>Duplex path
  Enable
```

3 Press the **ENTER** key. A blinking question mark (?) appears.

```
>>Duplex path
? Enable
```

4 Select `Enable` or `Disable` using the `△` or `▽` key. For details of the default setting for each paper type, see [Chapter 2 Handling Paper, section 2.5 Paper Type on page 2-21](#).

5 Press the **ENTER** key.

6 Press the **MENU** key. The display returns to `Ready`.

The custom paper type setting is completed.

3.10.10 Resetting the Custom Paper Type

If you want to reset all custom paper type settings to the factory default, proceed as follows:

1 Press the **MENU** key.

2 Press the Δ or ∇ key repeatedly until Paper Handling > appears.

```
Paper Handling >
```

3 Press the \triangleright key.

4 Press the Δ or ∇ key repeatedly until >Reset Type Adjust appears.

```
>Reset Type  
Adjust
```

5 To reset all custom paper types, press the **ENTER** key. A question mark (?) appears.

```
>Reset Type  
Adjust ?
```

6 Press the **ENTER** key. All customized paper types will be reset to the default. The display returns to Ready.

3.10.11 Selecting the Output Stack

The Stack Select menu on the operator panel allows you to select either the face-down tray or the face-up tray for the output stack.

- 1** Press the **MENU** key.
- 2** Press the Δ or ∇ key repeatedly until Paper Handling > appears.

```
Paper Handling >
```

- 3** Press the \triangleright key.
- 4** Press the Δ or ∇ key repeatedly until >Stack Select appears.

```
>Stack Select  
Face-down tray
```

- 5** To change the output stack, press the **ENTER** key. A blinking question mark (?) appears.

```
>Stack Select  
? Face-down tray
```

- 6** Press the Δ or ∇ key to toggle through the following output stacks:

```
Face-down tray  
Face-up tray
```

- 7** When the desired output stack is displayed, press the **ENTER** key.
- 8** To exit the menu selection, press the **MENU** key.

3.11 Selecting Monochrome or Color Printing

You can use the Color Mode menu on the operator panel to select the Monochrome or Color printing mode. By default, the printer is set to print in color mode. To change it to monochrome mode, proceed as follows:

1 Press the **MENU** key.

2 Press the Δ or ∇ key repeatedly until `Color Mode` appears.

```
Color Mode
Color
```

3 To change color mode, press the **ENTER** key. A blinking question mark (?) appears.

```
Color Mode
? Color
```

4 Press the Δ or ∇ key to change color mode — `Color` or `Monochrome`.

5 When the desired color mode is displayed, press the **ENTER** key. Color mode is changed.

6 To exit the menu selection, press the **MENU** key.

3.12 Reading Life Counters

You can display the total number of pages printed by your printer whenever it is necessary. The total number of printed pages can also be checked on the status page. See [section 3.3.2 Printing a Status Page on page 3-17](#). For proper maintenance scheduling, you need to reset the toner counter using this menu each time a new toner container is installed.

3.12.1 Displaying the Total Printed Pages

This procedure displays the total number of printed pages. You cannot change the displayed value.

- 1** Press the **MENU** key.
- 2** Press the Δ or ∇ key repeatedly until `Life Counters >` appears.

```
Life Counters >
```

- 3** Press the \triangleright key.
- 4** Press the Δ or ∇ key repeatedly until `>Total Print` appears and the latest total print count is shown.

```
>Total Print  
0123456
```

- 5** To exit the menu selection, press the **MENU** key.

3.12.2 Resetting the Toner Counter

The toner containers must be replaced when the printer displays the `Low toner` or `Replace toner` message which will be given depending on the color of toner. The `Low toner` message will be shown as a pre-warning that the toner is running out and the printer will soon stop, at that time showing `Replace toner`. If you replace the toner container before `Replace toner` is displayed, you must manually reset the toner counter as explained below.

Note that if you reset the toner counter before the toner container is replaced, the subsequent toner warnings will not be indicated correctly.

1 Replace the toner container according to the message given on the message display. To replace the toner containers, see [Chapter 5 Maintenance, section 5.1 Toner Container Replacement on page 5-2](#).

2 Press the **MENU** key.

3 Press the Δ or ∇ key repeatedly until `Life Counters >` appears.

```
Life Counters >
```

4 Press the \triangleright key.

5 Press the Δ or ∇ key repeatedly until the message display shows the toner container of the color you replaced — `[C]yan`, `[M]agenta`, `[Y]ellow`, or `blac[K]`. For example, to reset the Cyan toner counter, display `>New Toner [C] Installed`.

6 Press the **ENTER** key. A question mark (?) appears.

```
>New Toner [C]  
Installed ?
```

7 Press the **ENTER** key. The toner counter is reset.

8 To exit the menu selection, press the **MENU** key.

3.13 Other Modes

The following modes can be accessed in the `Others` submenu:

- Message Language
- Automatic Form Feed Timeout Setting
- Sleep Timer Setting
- Received Data Dumping
- Printer Resetting
- Resource Setting
- Alarm (Buzzer) Setting
- Auto Continue Setting
- Duplex Printing Error Detection Setting
- Color Registration
- Service Menu (for service personnel)
- Color Calibration

3.13.1 Selecting the Message Language

You can select the language of the messages on the message display by following the procedure given below. You can optionally download messages in other languages. Contact your Kyocera Mita dealer for information.

- 1** Press the **MENU** key.
- 2** Press the Δ or ∇ key repeatedly until `Others >` appears.

```
Others >
```

- 3** Press the \triangleright key.
- 4** Press the Δ or ∇ key repeatedly until `>MSG Language` appears. The default message language is `English`.

```
>MSG Language
English
```

- 5** To change the language, press the **ENTER** key. A blinking question mark (?) appears.

```
>MSG Language
? English
```

- 6 Press the Δ or ∇ key. The display cycles through the available selection in the following order:

English
Francais
Deutsch
Italiano
Nederlands
Español
Português

- 7 Press the **ENTER** key.
- 8 Press the **MENU** key. The display returns to Ready.

3.13.2 Automatic Form Feed Timeout Setting

If the printer receives no data for a certain period, it will time out and release the current interface. It prints whatever data it has in its buffer and feeds out the page. The default form feed timeout time is 30 seconds. You can adjust the time-out time as follows:

- 1 Press the **MENU** key.
- 2 Press the Δ or ∇ key repeatedly until `Others >` appears.

```
Others >
```

- 3 Press the \triangleright key.
- 4 Press the Δ or ∇ key repeatedly until `>Form Feed Time Out 030sec.` appears.

```
>Form Feed  
Time Out 030sec.
```

- 5 To change the timeout time, press the **ENTER** key. A blinking cursor (`_`) appears.

```
>Form Feed  
Time Out 030sec.
```

- 6 Press the Δ or ∇ key to increase or decrease the value at the blinking cursor and set the desired time. The timeout time can be between 0 and 495 seconds, in 5-second increments. Use the \triangleright and \triangleleft keys to move the cursor right and left.
- 7 When the desired timeout time is displayed, press the **ENTER** key.
- 8 To exit the menu selection, press the **MENU** key.

3.13.3 Setting the Sleep Timer

The printer has a sleep timer that is used to conserve power when the printer is not printing, processing, or receiving data. You can turn off or on the sleep timer function using the following procedure.

- 1** Press the **MENU** key.
- 2** Press the Δ or ∇ key repeatedly until `Others >` appears.

```
Others >
```

- 3** Press the \triangleright key.
- 4** Press the Δ or ∇ key repeatedly until `>Sleep Timer >` appears.

```
>Sleep Timer >
015 min.
```

- 5** Press the \triangleright key and display `>>Sleep Mode`.

```
>>Sleep Mode
On
```

- 6** To turn off the sleep timer, press the **ENTER** key. A blinking question mark (?) appears.

```
>>Sleep Mode
? On
```

- 7** Press the Δ or ∇ key to change `On` to `Off`.

```
>>Sleep Mode
? Off
```

- 8** Press the **ENTER** key. The sleep timer is turned off.
- 9** To exit the menu selection, press the **MENU** key.

Sleep Timer Timeout Time

You can adjust the timer timeout time, the length of time the printer waits before entering sleeping mode in the absence of data. The default sleep timer timeout time is 15 minutes.

The printer reverts to normal operation mode when the printer receives a print job, the operator panel is operated, or one of the exterior covers is opened.



Note

Color calibration is automatically executed before the printer reverts to normal operation mode.

To confirm and change the timeout time, proceed as follows:

- 1** Press the **MENU** key.
- 2** Press the Δ or ∇ key repeatedly until `Others >` appears.

```
Others >
```

- 3** Press the \triangleright key.
- 4** Press the Δ or ∇ key repeatedly until `>Sleep Timer >` appears.

```
>Sleep Timer >
      015min.
```

- 5** To change the timeout time, press the **ENTER** key. A blinking cursor (`_`) appears.

```
>Sleep Timer
      015min.
```

- 6** Press the Δ or ∇ key to increase or decrease the value at the blinking cursor and set the desired time. The timer can be set between 5 and 240 min, in 5-minute increments. Use the \triangleright and \triangleleft keys to move the cursor right and left.
- 7** When the desired timeout time is displayed, press the **ENTER** key.
- 8** To exit the menu selection, press the **MENU** key.

3.13.4 Received Data Dump

You can print data received by the printer as hexadecimal code for debugging programs and files.

1 Press the **MENU** key.

2 Press the Δ or ∇ key repeatedly until `Others >` appears.

```
Others >
```

3 Press the \triangleright key.

4 Press the Δ or ∇ key repeatedly until `>Print HEX-DUMP` appears.

```
>Print HEX-DUMP
```

5 Press the **ENTER** key. A question mark (?) appears.

```
>Print HEX-DUMP?
```

6 Press the **ENTER** key again. The message `Processing` appears for a second, followed by `Waiting`.

```
Processing
```



```
Waiting
```

7 While the message display is indicating `Waiting` (for 30 seconds by default), send data to be hex-dumped to the printer. The message display indicates `Processing` while the data is being received.

You can cancel printing of any more dump data by pressing the **GO** key and then the **CANCEL** key.

8 Once all data has been received, the message `Waiting` will appear. Press the **GO** key to finish hex-dump printing.

3.13.5 Printer Resetting

The procedure described below resets the printer's temporary conditions, such as the current page orientation, font, etc., set by commands to their default values. Downloaded fonts and macros are deleted from the printer's memory.

- 1** Press the **MENU** key.
- 2** Press the Δ or ∇ key repeatedly until `Others >` appears.

```
Others >
```

- 3** Press the \triangleright key.
- 4** Press the Δ or ∇ key repeatedly until `>Printer Reset` appears.

```
>Printer Reset
```

- 5** To reset the printer, press the **ENTER** key. A question mark (?) appears.

```
>Printer Reset ?
```

- 6** Press the **ENTER** key again. `Self test` appears while the printer is resetting itself, followed by `Please wait` and then `Ready`.

```
Self test
```



```
Please wait
```



```
Ready
```

3.13.6 Resource Protection

By default, when you switch from the PCL 6 emulation to another, all downloaded fonts and macros will be lost. Resource protection preserves these PCL resources in memory so that they remain intact even when you have switched back in PCL 6.



Note

Resource protection requires extra memory to store the downloaded fonts and macros. The total size of the printer memory recommended for using the resource protection option is affected by several factors. See [Appendix A Options](#).

By default, resource protection is deactivated. To activate resource protection, proceed as follows:

- 1** Press the **MENU** key.
- 2** Press the Δ or ∇ key repeatedly until `Others >` appears.

```
Others >
```

- 3** Press the \triangleright key.
- 4** Press the Δ or ∇ key repeatedly until `>Resource Prot.` appears.

```
>Resource Prot.
Off
```

- 5** Press the **ENTER** key. A blinking question mark (?) appears.

```
>Resouce Prot.
? Off
```

- 6** Press the Δ or ∇ key to select `Permanent` or `Perm / Temp` (Permanent/Temporary) for resource protection.
- 7** When the desired resource protection is displayed, press the **ENTER** key.
- 8** To exit the menu selection, press the **MENU** key.

3.13.7 Alarm (Buzzer) Setting

You can set an alarm sound in addition to the message displayed when the paper supply is exhausted, or when paper jamming occurs. This setting is useful, for example, when the printer is located some distance from the user.

The audio alarm is set to `On` when leaving the factory. If the alarm is set to `Off`, it will not sound.

- 1** Press the **MENU** key.
- 2** Press the Δ or ∇ key repeatedly until `Others >` appears.

```
Others >
```

- 3** Press the \triangleright key.
- 4** Press the Δ or ∇ key repeatedly until `Buzzer` appears.

```
>Buzzer  
On
```

- 5** Press the **ENTER** key. A blinking question mark (?) appears.

```
>Buzzer  
? On
```

- 6** Select `On` or `Off` using the Δ or ∇ key.
- 7** Press the **ENTER** key.
- 8** To exit the menu selection, press the **MENU** key.

3.13.8 Auto Continue Setting

If an error that still allows you to continue printing occurs (Memory overflow Press GO, Print overrun Press GO, KPDL error Press GO, File not found Press GO, RAM disk error Press GO, MemoryCard err Press GO, Hard disk err Press GO, and Duplex disabled Press GO), the next received data is automatically printed after a set period of time elapses. For example, if the printer is shared over a network as a network printer and one person causes one of the above errors, after the set period of time elapses, the data sent from the next person is printed. The default setting is Off (Auto Continue disabled).



Note

For setting the auto continue recovery time, see the next section.

- 1** Press the **MENU** key.
- 2** Press the Δ or ∇ key repeatedly until `Others >` appears.

```
Others >
```
- 3** Press the \triangleright key
- 4** Press the Δ or ∇ key repeatedly until `>Auto Continue >` appears.

```
>Auto Continue >
Mode Off
```
- 5** Press the **ENTER** key. A blinking question mark (?) appears.

```
>Auto Continue
Mode ? Off
```
- 6** Select `On` or `Off` using the Δ or ∇ key.
- 7** Press the **ENTER** key.
- 8** To exit the menu selection, press the **MENU** key. The display returns to `Ready`.

3.13.9 Setting the Auto Continue Recovery Time

Follow the procedure given below to change the recovery time for Auto Continue.

- 1 Press the **MENU** key.
- 2 Press the Δ or ∇ key repeatedly until `Others >` appears.

```
Others >
```

- 3 Press the \triangleright key.
- 4 Press the Δ or ∇ key repeatedly until `>Auto Continue Mode On` appears.

```
>Auto Continue >  
Mode On
```

- 5 Press the \triangleright key and display `>> Auto Continue Timer`. The default setting is 30 seconds.

```
>>Auto Continue  
Timer 030sec.
```

- 6 Press the **ENTER** key. A blinking cursor (`_`) appears.

```
>>Auto Continue  
Timer 030sec.  
                  ^
```

- 7 Press the Δ or ∇ key to increase or decrease the value at the blinking cursor and set the desired time. The time must be set between 000 and 495 seconds, in 5-second increments. If set to 000, printing will be continued immediately without any time interval. You can use the \triangleright and \triangleleft keys to move the cursor right and left.
- 8 Display the desired time and press the **ENTER** key.
- 9 Press the **MENU** key. The display returns to `Ready`.

3.13.10 Duplex Printing Error Detection Setting

If the error detection setting for duplex printing has been turned On, and you attempt to print onto a paper size and paper type that cannot be used for duplex printing, the Duplex disabled Press GO error message will be displayed and printing will stop. To print onto one-side of the paper only when this message is displayed, press the **GO** key. The default setting is Off.

- 1** Press the **MENU** key.
- 2** Press the Δ or ∇ key repeatedly until Others > appears.

```
Others      >
```

- 3** Press the \triangleright key.
- 4** Press the Δ or ∇ key repeatedly until >Finishing Error > appears.

```
>Finishing >
Error
```

- 5** Press the \triangleright key and display >>Duplex.

```
>>Duplex
Off
```

- 6** Press the **ENTER** key. A blinking question mark (?) appears.

```
>>Duplex
? Off
```

- 7** Press the Δ or ∇ key to change Off to On.

```
>>Duplex
? On
```

- 8** Press the **ENTER** key.
- 9** To exit the menu selection, press the **MENU** key.

3.13.11 Color Registration

When using the printer for the first time after set-up or after having moved it, or if printout of any color (cyan, magenta or yellow) is skewed, use this mode to correct the color registration on the operator panel.

1 Press the **MENU** key.

2 Press the Δ or ∇ key repeatedly until `Others >` appears.

```
Others >
```

3 Press the \triangleright key.

4 Press the Δ or ∇ key repeatedly until `>Color Registration >` appears.

```
>Color >  
Registration
```

5 Press the \triangleright key.

6 Press the Δ or ∇ key repeatedly until `>>Print Regist Chart` appears.

```
>>Print  
Regist Chart
```

7 Press the **ENTER** key. A question mark (?) appears.

```
>>Print  
Regist Chart ?
```

- 8** Press the **ENTER** key. Processing appears and a color registration correction chart is printed out. There are left (L), horizontal (H) and right (R) registration charts for each color (cyan, magenta and yellow) included on the color registration correction chart.

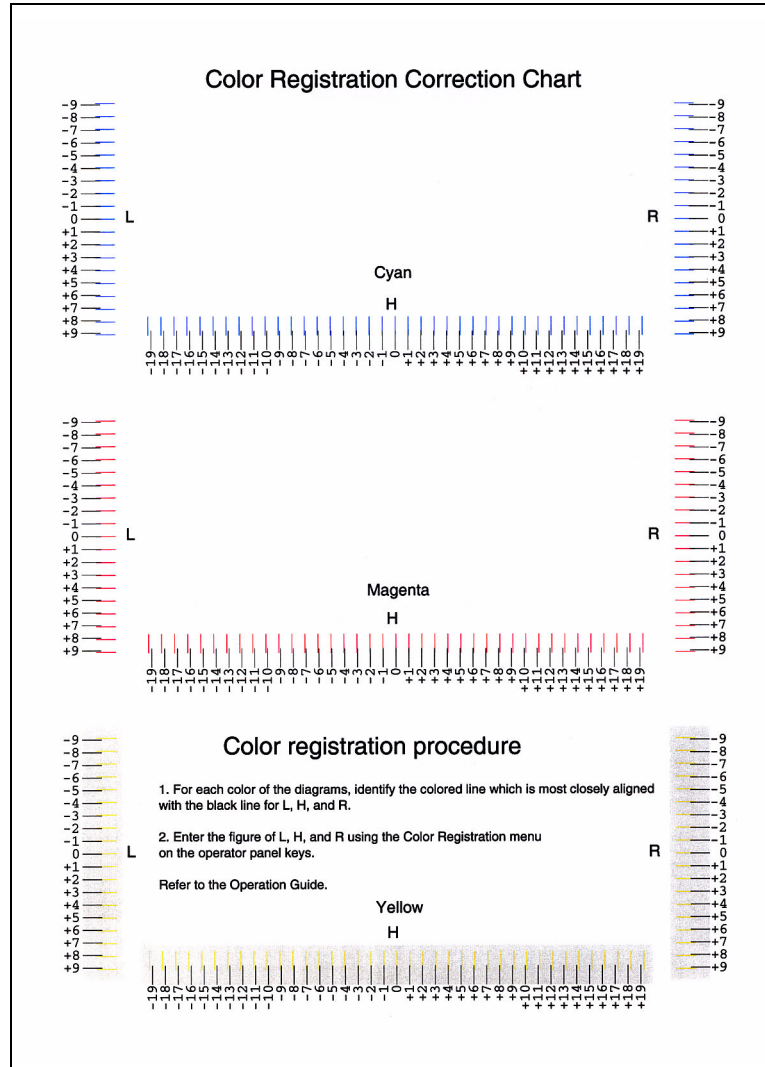

Figure 3-16

- 9** Press the Δ or ∇ key repeatedly until >>Adjust Cyan appears.

```
>>Adjust Cyan
L=   H=   R=
```

- 10** Press the **ENTER** key. 0 or 00 will be displayed for each value and the cursor will flash under the left (L) value.

```
>>Adjust Cyan
L= 0 H= 00 R= 0
```

- 11** Look at the left chart (L) in the cyan portion of the color registration correction chart. Find the two lines that most seem to overlap as a single straight line and note the number value listed there. In the example below the value would be -2. (Be careful of plus [+] and minus[-] numbers.)

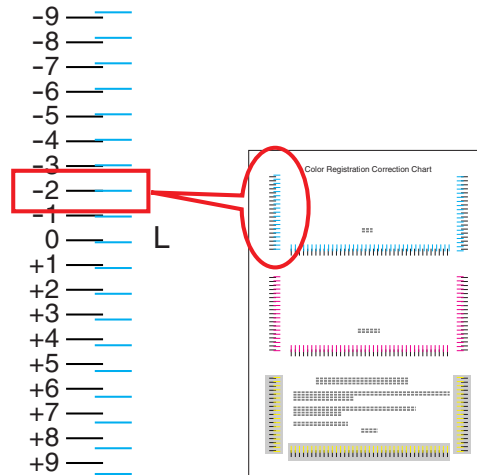

Figure 3-17

- 12** Press the Δ or ∇ key until that value is displayed.

```
>>Adjust Cyan
L=-2 H= 00 R= 0
```

- 13** Use the \triangleright and \triangleleft keys to move the cursor right and left. Perform the same operation as you did for the left (L) value in order to find the horizontal (H) and right (R) values for cyan in the color registration correction chart, and select those values on the operator panel as well.

- 14** Press the **ENTER** key. OK? and each of the entered values will be displayed. If the displayed values are correct, press the **ENTER** key.

```
OK?
L=-2 H= 00 R=+1
```

- 15** Press the ∇ key. >>Adjust Magenta will be displayed and, once you complete the settings for that color, >>Adjust Yellow will be displayed as well. Perform the same operation as you did for the cyan chart in order to find the values for magenta and yellow in the color registration correction chart, and perform those settings in the same way.

- 16** Once you have completed the settings for all 3 colors, press the **MENU** key. The display returns to Ready.



If the problem of skewed-color printout still persists even after correcting the color registration, call for service.

3.13.12 Printing the Service Status Page

The service status page contains printer settings information that is more detailed than the standard status page and is therefore mostly for service purposes. However, since there is a great deal of information on the service status page that may be useful to you, the procedure for printing it out is given below.

- 1** Press the **MENU** key.
- 2** Press the Δ or ∇ key repeatedly until `Others >` appears.

```
Others >
```

- 3** Press the \triangleright key.
- 4** Press the Δ or ∇ key repeatedly until `>Service >` appears.

```
>Service >
```

- 5** Press the \triangleright key.
- 6** Press the Δ or ∇ key repeatedly until `>>Print Status Page` appears.

```
>>Print  
Status Page
```

- 7** Press the **ENTER** key. A question mark (?) appears.

```
>>Print  
Status Page ?
```

- 8** Press the **ENTER** key. The display indicates `Processing` and printing starts.

3.13.13 Color Calibration

This printer contains a calibration function that automatically makes adjustments in compensation for secular changes that occur over time due to variations in the ambient temperature and humidity. So that the highest quality color printing can be maintained, this color calibration operation is carried out automatically each time the power to the printer is turned on. The color calibration operation may be carried out automatically during recovery from the Sleep mode or during printing.

To manually carry out the color calibration operation, perform the following procedure.

1 Press the **MENU** key.

2 Press the Δ or ∇ key repeatedly until `Others >` appears.

```
Others >
```

3 Press the \triangleright key.

4 Press the Δ or ∇ key repeatedly until `>Service >` appears.

```
>Service >
```

5 Press the \triangleright key.

6 Press the Δ or ∇ key repeatedly until `>>Color Calibration` appears.

```
>>Color  
Calibration
```

7 To let the printer perform color calibration, press the **ENTER** key. A question mark (?) appears to let you confirm the execution of calibration.

```
>>Color  
Calibration ?
```

8 Press the **ENTER** key. The message display shows `Please wait (Calibrating)` and calibration will start.

```
Please wait  
(Calibrating)
```

9 When calibration is finished, the display returns to `Ready`.

Chapter 4 Troubleshooting

This chapter explains how to handle printer problems that may occur. If a problem cannot be corrected, contact your Kyocera Mita dealer. This chapter explains the following topics:

- *General Guidelines*
- *Print Quality Problems*
- *Error Messages*
- *Clearing Paper Jams*

4.1 General Guidelines

The table below provides basic solutions for problems you may encounter with the printer. We suggest you consult this table to troubleshoot the problems before calling for service.

Symptom	Check Items	Corrective Action
Print quality is not good.	See Section 4.2 Print Quality Problems on page 4-3 .	
Paper is jammed.	See Section 4.4 Clearing Paper Jams on page 4-12 .	
Nothing lights on the operator panel even when power is turned on and the fan makes no noise.	Check that the power cord is properly plugged into the power outlet.	Turn off the printer's power, plug in the power cord securely, and try turning on the printer's power again.
	Check that the power switch is in the On (I) position.	Set the power switch to the On position.
The printer prints a status page, but does not print jobs from the computer.	Check the printer cable or the interface cable.	Connect both ends of the printer cable securely. Try replacing the printer cable or the interface cable.
	Check program files and application software.	Try printing another file or using another print command. If the problem occurs only with a specific file or application, check the printer driver settings for that application.

Table 4-1

4.1.1 Tips

Printer problems may be solved easily by following the tips below. When you have encountered a problem that following the above guidelines will not solve, try the following:

- Turn the printer power off and wait for several seconds. Then, turn on the printer.
- Reboot the computer which sends the print jobs to the printer.
- Obtain and use the latest version of the printer driver. The latest versions of printer drivers and utilities are available at: <http://www.kyoceramita.com/download/>.
- Make sure that the procedures for printing are correctly followed in the application software. Consult the documentation supplied with the application software.
- If the printer prints garbage characters or stalls when the computer is turned on, particularly when the printer is connected to the computer under Windows 98 via the parallel port, rename device driver file drvwppqt.vxd. This file may be located in Windows\System\Iosubsys or Arcada\System folder. For technical details, visit Microsoft web site for the device driver.

4.2 Print Quality Problems

The tables and diagrams in the following sections define print quality problems and the corrective action you can conduct to solve the problems. Some solutions may require cleaning or replacing parts of the printer.

If the suggested corrective action will not solve the problem, call for service.

Printed Results	Corrective Action
<p>Completely blank printout</p> 	<p>Check the toner containers.</p> <p>Open the printer top cover and check that the toner containers are correctly installed in the printer. For more information on installing the toner containers, see Chapter 5 Maintenance, section 5.1 Toner Container Replacement on page 5-2.</p> <hr/> <p>Check that the application software is correctly operated.</p>
<p>Full single-color printout</p> 	<p>Check the charger unit.</p> <p>Open the left cover and check that the charger unit is correctly installed.</p> <hr/> <p>Check the advanced beam array lens cleaners.</p> <p>Open the left cover and make sure that the lens cleaners are securely pushed all the way into the printer. For full details, see Chapter 5 Maintenance, section 5.3.3 Cleaning the Advanced Beam Array Lenses on page 5-17.</p>
<p>Dropouts, horizontal streaks, stray dots</p> 	<p>Clean the main charger units.</p> <p>Open the left cover. Slowly pull the green wire cleaner knob to each of the main charger units in and out a few times. For full details, see Chapter 5 Maintenance, section 5.3.1 Cleaning the Main Charger Unit on page 5-11.</p>

Table 4-2

Printed Results	Corrective Action
<p>Black or white vertical streaks</p> 	<p>Check the operator panel for toner.</p> <p>If the Toner low (C/M/Y/K) message is displayed with color description, install a new toner kit for the color. To replace the toner container, see Chapter 5 Maintenance, section 5.1 Toner Container Replacement on page 5-2.</p> <hr/> <p>Clean the main charger units.</p> <p>Open the left cover. Slowly pull the green wire cleaner knob to each of the main charger units in and out a few times. For full details, see Chapter 5 Maintenance, section 5.3.1 Cleaning the Main Charger Unit on page 5-11.</p> <hr/> <p>Clean the advanced beam array lenses.</p> <p>Open the left cover. Slowly pull the green lens cleaner knob in and out 2 times. For full details, see Chapter 5 Maintenance, section 5.3.3 Cleaning the Advanced Beam Array Lenses on page 5-17.</p>
<p>Faint or blurred printing</p> 	<p>Clean the main charger units.</p> <p>Open the left cover. Slowly pull the green wire cleaner knob to each of the main charger units in and out a few times. For full details, see Chapter 5 Maintenance, section 5.3.1 Cleaning the Main Charger Unit on page 5-11.</p> <hr/> <p>Clean the advanced beam array lenses.</p> <p>Open the left cover. Slowly pull the green lens cleaner knob in and out 2 times. For full details, see Chapter 5 Maintenance, section 5.3.3 Cleaning the Advanced Beam Array Lenses on page 5-17.</p> <hr/> <p>Make sure the paper type setting is correct the paper being used. See Chapter 3 Using the Operator Panel, section 3.10.5 Setting the Cassette Paper Type on page 3-76.</p> <hr/> <p>Conduct color calibration either by switching the printer off then on or using the printer operator panel. For full details, see Chapter 3 Using the Operator Panel, section 3.13.13 Color Calibration on page 3-104.</p> <hr/> <p>Try adjusting the color control settings using the printer driver.</p> <hr/> <p>Check the operator panel. If the Toner low (C/M/Y/K) message is displayed with color description, install a new toner kit for the color. To replace toner, see Chapter 5 Maintenance, section 5.1 Toner Container Replacement on page 5-2.</p>

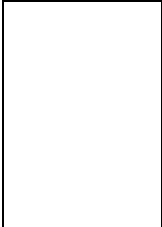
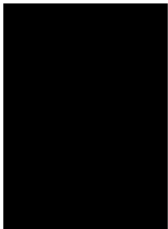
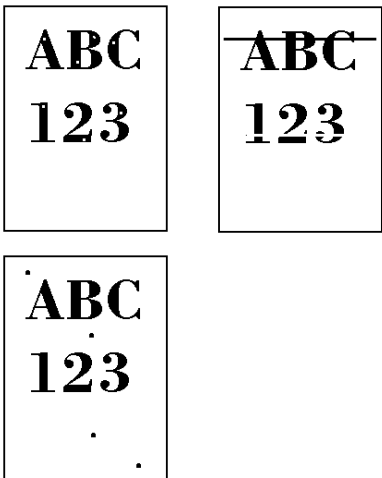

Table 4-2 (Continued)

Printed Results	Corrective Action
Grey background	<p>Clean the main charger units.</p> <p>Open the left cover. Slowly pull the green wire cleaner knob to each of the main charger units in and out a few times. For full details, see Chapter 5 Maintenance, section 5.3.1 Cleaning the Main Charger Unit on page 5-11.</p> <hr/> <p>Check the charger units installation.</p> <p>Open the left cover and check that the charger units are correctly installed and seated as far as it will go. See Chapter 5 Maintenance, section 5.3 Cleaning the Printer on page 5-11.</p> <hr/> <p>Conduct color calibration either by switching the printer off then on or using the printer operator panel. For full details, see Chapter 3 Using the Operator Panel, section 3.13.13 Color Calibration on page 3-104.</p>
Dirt on the top edge or back of the paper	<p>Check the paper chute and the ramp.</p> <p>Pull out the paper transfer unit and check for toner on the paper ramp. Clean the paper ramp using a soft, dry, lint-free cloth. For details, see Chapter 5 Maintenance, section 5.3.2 Cleaning the Paper Transfer Unit on page 5-16.</p>

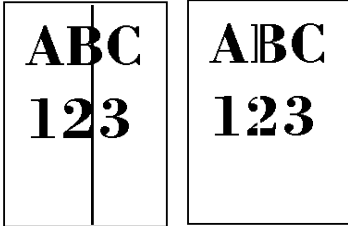
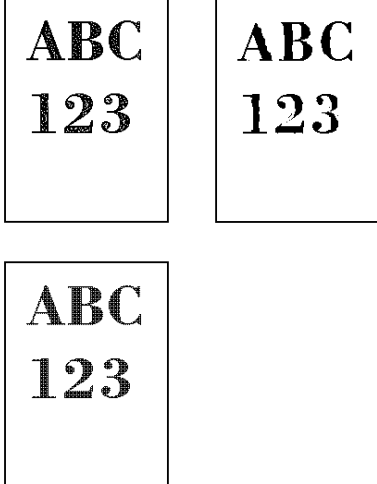
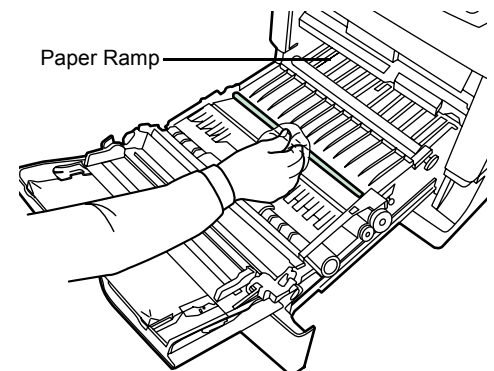
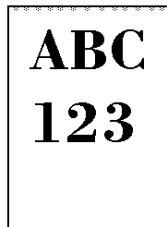
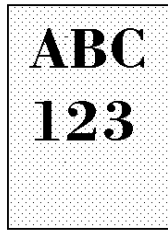

Table 4-2 (Continued)

Printed Results	Corrective Action
Printing incomplete or out of position	Check that the application software is correctly operated.
	See 4.1.1 Tips on page 4-2 .
Skewed-color printout	Conduct color registration using the printer operator panel. For full details, see Chapter 3 Using the Operator Panel, section 3.13.11 Color Registration on page 3-100 .
	

Table 4-2 (Continued)

4.3 Error Messages

The following table lists errors and maintenance messages that you can be dealt with by yourself. If **Call service** appears, turn off the printer, disconnect the power cord, and contact your Kyocera Mita dealer.

Some errors cause the alarm sound to sound. To stop the alarm sound, press the **CANCEL** key to stop the alarm sound.

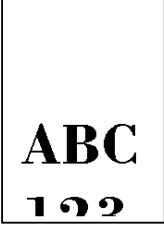
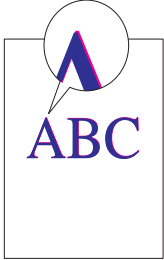
Message	Corrective Action
Add paper MPTray	The paper has run out in the paper source displayed. Supply paper according to the paper source displayed (paper cassettes, MP tray, optional paper feeders, or optional envelope feeder). This message is displayed alternately with messages indicating the printer status, such as, Ready, Please wait, Processing, Waiting, and Form Feed Time Out. If the number of copies to print is 2 or more, only the Add paper message is displayed.
Call service F###:	F### represents a controller error (#=0, 1, 2, ...). Call for service. The printer does not operate when this message is displayed.
Call service ####:0123456	#### represents a mechanical error (#=0, 1, 2, ...). Call for service. The printer does not operate when this message is displayed. The total number of pages printed is also indicated, e.g. 0123456.
Call service Person F0	This message means an error in data communications between the printer controller and the operator panel. Call for service.
Cassette # not loaded	The corresponding paper cassette is not installed. Install the cassette. The cassette number can be 1 (topmost) to 4 (bottom).
Check waste toner box	This message warns following two cases. Install the new waste toner box. <ul style="list-style-type: none"> The waste toner box is not installed. The waste toner box is almost full.
Clean printer Press GO	Please clean the inside of the printer. See Chapter 5 Maintenance, section 5.3 Cleaning the Printer on page 5-11 . This message will be displayed when replacing the toner container after the message Replace toner C, M, Y, K is displayed. After cleaning the inside of the printer, press the GO key and the printer will be ready for printing. If Auto Continue is set to On, printing will be automatically resumed after a preset period of time. For details on Auto Continue, refer to Chapter 3 Using the Operator Panel, section 3.13.8 Auto Continue Setting on page 3-97 .
Close duplexer rear unit	The rear unit of the optional duplexer is open. Close the duplexer rear unit.
Close duplexer top cover	The top cover of the optional duplexer is open. Close the duplexer top cover.
Close paper transfer unit	The paper transfer unit is open. Close the paper transfer unit.

Table 4-3

Message	Corrective Action
Close left cover	The left cover of the printer is open. Close the left cover.
Close rear cover	The rear cover of the printer is open. Close the printer rear cover.
Close top cover	The top cover of the printer is open. Close the printer top cover.
Duplex disabled Press GO	You attempted to print with a paper size and paper type that cannot be used for duplex printing. Press the GO key to print onto one-side of the paper only.
Face-down tray paper full	The face-down tray has become full (approx. 250 pages). You must remove all printed pages from the face-down tray. When the printer detects that the face-down tray is empty again, the printer will continue printing into the face-down tray.
File not found Press GO	You have attempted to print a job that is not contained in the specified virtual mailbox, or the specified virtual mailbox is not found. If Auto Continue is set to On, printing will be automatically resumed after a preset period of time. For details on Auto Continue, refer to Chapter 3 Using the Operator Panel, section 3.13.8 Auto Continue Setting on page 3-97 .
Format error Hard disk	The hard disk installed in the printer is not formatted, and therefore cannot be read or written. To format the hard disk, follow the procedure in the Installation Guide of the hard disk.
Format error Memory card	The memory card inserted in the printer is not formatted, and therefore cannot be read or written. To format a memory card, follow the procedure in Chapter 3 Using the Operator Panel, section Formatting a Memory Card on page 3-63 .
Hard disk err ## Press GO	A hard disk error has occurred. Look at the error code given in place of ## and refer to Storage Error Codes on page 4-11 . To ignore the hard disk error, press the GO key.
I/F occupied	This message is displayed when you attempt to use the printer's operator panel to change the environmental settings on the interface from which data are presently being received.
ID error	The user ID entered for a private job, or a stored job is not correct. Check the user ID that you specified on the printer driver.
Insert the same memory card	You have inserted the wrong memory card when the Insert again message was displayed. Remove the wrong memory card from the printer's memory card slot and insert the correct memory card. The printer again reads it from the beginning of the data.
Install MK	Replace Maintenance Kit which is displayed on the message display. Replacement of the maintenance kit is necessary at every 200,000 images of printing and requires professional servicing. Contact your Kyocera Mita dealer.
KPDL error ## Press GO	Current print processing cannot continue because of occurrence of KPDL error which is categorized by ##. To print out an error report, display > Print KPDL err(s) from the menu system, and select On. Press the GO key to resume printing. You can abandon printing by the CANCEL key. If Auto Continue is set to On, printing will be automatically resumed after a preset period of time. For details on Auto Continue, refer to Chapter 3 Using the Operator Panel, section 3.13.8 Auto Continue Setting on page 3-97 .

Table 4-3 (Continued)

Message	Corrective Action
Load Cassette # (A4)/(PLAIN) [†]	<p>The paper cassette matching the paper size and paper type of the print job is empty. Load paper into the paper cassette as displayed in place of #. Press the GO key to resume printing.</p> <p>If you want to print from a different paper source, press the Δ or ∇ key to display <i>Use alternative</i> and you can change the source for paper feeding. After selecting a paper source and pressing the MENU key, <i>Paper Handling ></i> appears. By pressing the Δ key, the paper type settings menu appears. After setting the correct paper type, press the ENTER key and printing starts. For details, see Chapter 3 Using the Operator Panel, section 3.10.6 Selecting the Paper Feed Source on page 3-77.</p>
Load EF (A5)/(PLAIN) [†]	<p>There is no paper cassette installed in the printer that matches the paper size and paper type of the print job. Set paper in the envelope feeder. Press the GO key to resume printing. (Note that feeding the paper having a paper size which does not match the current paper size from the envelope feeder can cause paper jam.)</p> <p>If you want to print from a different paper source, press the Δ or ∇ key to display <i>Use alternative</i> and you can change the source for paper feeding. After selecting a paper source and pressing the MENU key, <i>Paper Handling ></i> appears. By pressing the Δ key, the paper type settings menu appears. After setting the correct paper type, press the ENTER key and printing starts. For details, see Chapter 3 Using the Operator Panel, section 3.10.6 Selecting the Paper Feed Source on page 3-77.</p>
Load MP Tray (A4)/(PLAIN) [†]	<p>There is no paper cassette installed in the printer that matches the paper size and paper type of the print job. Set paper in the MP tray. Press the GO key to resume printing. (Note that feeding the paper having a paper size which does not match the current paper size from the MP tray can cause paper jam.)</p> <p>If you want to print from a different paper source, press the Δ or ∇ key to display <i>Use alternative</i> and you can change the source for paper feeding. After selecting a paper source and pressing the MENU key, <i>Paper Handling ></i> appears. By pressing the Δ key, the paper type settings menu appears. After setting the correct paper type, press the ENTER key and printing starts. For details, see Chapter 3 Using the Operator Panel, section 3.10.6 Selecting the Paper Feed Source on page 3-77.</p>
Memory card err Insert again	<p>The memory card is accidentally removed from the printer's memory card slot during reading. If you continue reading the memory card, insert the same memory card into the slot again. The printer again reads it from the beginning of the data.</p> <p>Also see Insert the same memory card.</p>
Memory overflow Press GO	<p>The total amount of data received by the printer exceeds the printer's internal memory. Try adding more memory. Press the GO key to resume printing. You can abandon printing by the CANCEL key.</p> <p>If Auto Continue is set to On, printing will be automatically resumed after a preset period of time. For details on Auto Continue, refer to Chapter 3 Using the Operator Panel, section 3.13.8 Auto Continue Setting on page 3-97</p>
MemoryCard err## Press GO	<p>A memory card error has occurred. Look at the error code given in place of ## and refer to Storage Error Codes on page 4-11. To ignore the memory card error, press the GO key</p>
Missing duplex drawer	<p>The duplex drawer is either not installed or incorrectly inserted. Insert the duplex drawer securely.</p>
Paper jam #####	<p>A paper jam has occurred. The location of the paper jam is indicated in place of the #'s. For details, see Section 4.4 Clearing Paper Jams on page 4-12.</p>

Table 4-3 (Continued)

Message	Corrective Action
Paper path error	There is no paper cassette in the feeder, or the cassette is not inserted properly. After reinserting the paper cassette, you should be able to print. When two or more optional feeders are installed and the lowest one is selected, the same message will appear if any of the upper paper feeder and the printer cassette is improperly installed.
Print overrun ^{††} Press GO	The print job transferred to the printer was too complex to print on a page. Press the GO key to resume printing. (A page break may be automatically inserted in some places.) You can abandon printing by the CANCEL key. If Auto Continue is set to On, printing will be automatically resumed after a preset period of time. For details on Auto Continue, refer to Chapter 3 Using the Operator Panel, section 3.13.8 Auto Continue Setting on page 3-97
RAM disk error## Press GO	A RAM disk error has occurred. Look at the error code given in place of ## and refer to Storage Error Codes on page 4-11 . To ignore the RAM disk error, press the GO key.
Replace toner C, M, Y, K	Two message items are displayed alternately. Toner has run out in the toner container(s). Replace the toner container using a new toner kit for the particular color. The printer does not operate when this message is displayed. For example, if Replace toner C, K is displayed, replace the cyan and the black toner containers.
↓ ↑	
Replace toner Clean printer	
Set paper Press GO	The MP tray is out of paper. Load paper and press the GO key. (Note that feeding the paper having a paper size which does not match the current paper size from the MP tray can cause paper jam.)
Toner low C, M, Y, K	Replace the toner container using a new toner kit. Color of the toner container that needs to be replaced is represented by C (Cyan), M (Magenta), Y (Yellow), and K (Black).
Virtual mailbox full	The storage area in the hard disk for the virtual mailboxes is full. Print out accumulated jobs in the virtual mailboxes.
Warning low memory	The printer's internal memory is running low due to too many numbers of fonts and macros downloaded. Try deleting unnecessary fonts and macros.

Table 4-3 (Continued)

† Messages separated by '()/()' are displayed alternately.

†† After this error has happened, page protect mode will be automatically turned on. To maintain optimum use of memory during printing, we recommend you manually turn off page protect mode. See [Chapter 3 Using the Operator Panel, section 3.7.3 Page Protect Mode on page 3-54](#).

Storage Error Codes

Hard Disk Errors

Code	Meaning
01	Hard disk format error. If this error recurs even if the power has been turned off and then on, reformat the hard disk.
02	The disk system is not installed. Recheck the requirements for using the system and the devices.
04	There is no available hard disk space. Delete unnecessary files, etc., in order to free up space.
05	The specified file does not exist in the hard disk.
06	There is no memory available to the hard disk system. Increase the available memory.
10	Formatting is not possible because host data is being spooled on the hard disk. Wait until the hard disk is ready, and then format.
85	VMB: Alias error. The alias setting was lost, or the virtual tray corresponding to the alias does not exist. Set the alias again.
97	The number of permanent code jobs that can be stored reached the limit value, and no more can be saved. Either delete some unnecessary jobs, etc., or increase the limit.
98	An unreadable page was found in a job (The job is damaged.).
99	A print job for the specified ID does not exist in the hard disk.

Table 4-4

Memory Card Errors

Code	Meaning
01	The printer does not support the memory card inserted. The memory card must meet the requirements described in <i>Appendix A Options, section A.3.1 Memory Card on page A-7</i> .
02	The memory card is not installed.
04	The memory card is full and cannot hold further data. Purge unnecessary files or use a new memory card.
05	Specified file is not on the memory card.
06	Insufficient printer memory to support the memory card system. Expand printer memory.

Table 4-5

RAM Disk Errors

Code	Meaning
01	Format error. Try turning the power off and on again.
02	RAM disk mode is Off. Turn RAM disk mode On from the operator panel.
04	No disk space. Purge unnecessary files.
05	Specified file is not on disk.
06	Insufficient printer memory to support the RAM disk system. Expand printer memory.

Table 4-6

4.4 Clearing Paper Jams

If the paper jammed in the paper transport system, or no paper sheets were fed at all, the Paper jam message appears and the location of the paper jam (the component where the paper jam has occurred) is also indicated. The printer automatically goes off-line when this message is displayed. Remove jammed paper. After removing jammed paper, the printer will re-start printing.

4.4.1 Possible Paper Jam Locations

The figure below explains the printer's paper paths including the options. The locations where paper jams might occur are also shown here, with each location explained in [Table 4-7](#) below. Paper jams can occur in more than one component on the paper paths.

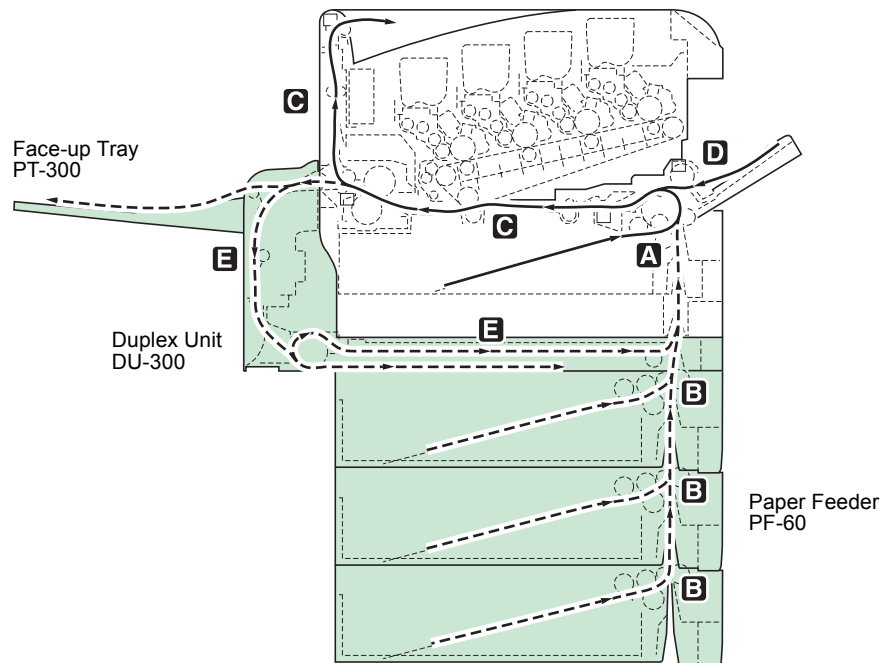

Figure 4-1

Paper jam message	Paper jam location	Description	Reference page
Paper jam Cassette 1	A	Paper is jammed at the paper cassette.	4-14
Paper jam Cassette 2 (to 4)	B	Paper is jammed at the optional paper feeder's cassette.	4-14
Paper jam Printer	C	Paper is jammed inside the printer.	4-15 4-16

Table 4-7

Paper jam message	Paper jam location	Description	Reference page
Paper jam MP Tray	D	Paper is jammed at the MP tray or optional envelope feeder (if installed).	4-17
Paper jam EF			
Paper jam Duplexer	E	Paper is jammed inside the rear cover of the optional duplexer or at the duplexer drawer.	4-17

Table 4-7

4.4.2 General considerations for clearing jams

Bear in mind the following considerations when attempting jam removal:



When pulling the paper, pull it gently so as not to tear it. Torn pieces of paper are difficult to remove and may be easily overlooked, deterring the jam recovery.

- If paper jams occur frequently, try using a different type of paper, replace the paper with paper from another ream, flip the paper stack over, or rotate the paper stack 180 degrees. Selection of paper is fully discussed in [Chapter 2 Handling Paper on page 2-1](#). The printer may have problems if paper jams recur after the paper was replaced.
- Whether or not the jammed pages are reproduced normally after printing is resumed depends on the location of the paper jam.

Utilizing Online Help Messages

Online help messages are available in the printer's message display to provide simple instructions for clearing jams. Press the () key when the paper jam message has appeared. Then a help message will appear to facilitate jam clearing in the location.

4.4.3 Jam at the Paper Cassette

Paper is jammed at the paper cassette or inside the printer. Remove the jammed paper using the procedure given below.

- 1** Pull out the paper cassette and remove the jammed paper.

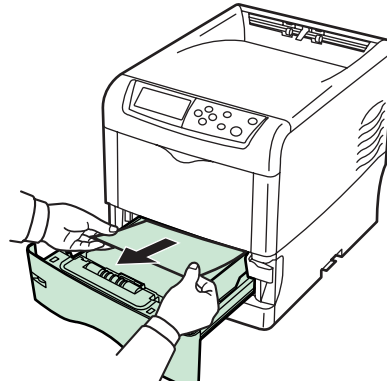

Figure 4-2

- 2** If paper is jammed at the standard paper cassette (Cassette 1), open and close the paper transfer unit (the paper jam error will be reset).

4.4.4 Jam at the Paper Transfer Unit

- 1** While pulling the green paper transfer unit release lever, pull out the paper transfer unit.

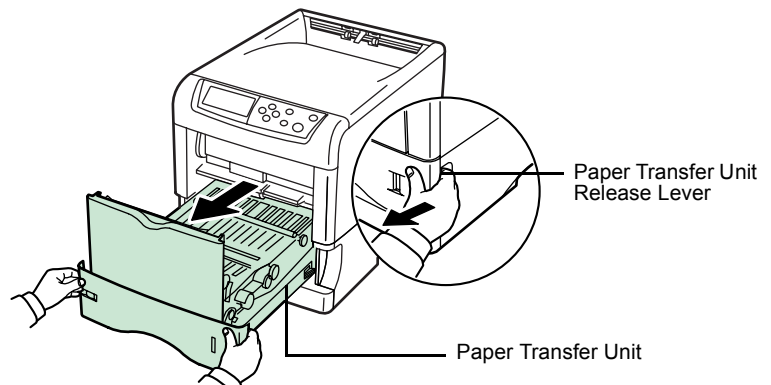

Figure 4-3

- 2** If paper is jammed as shown in **A**, remove the paper by pulling the center up. If paper is jammed as shown in **B**, remove the paper by pulling the edge.

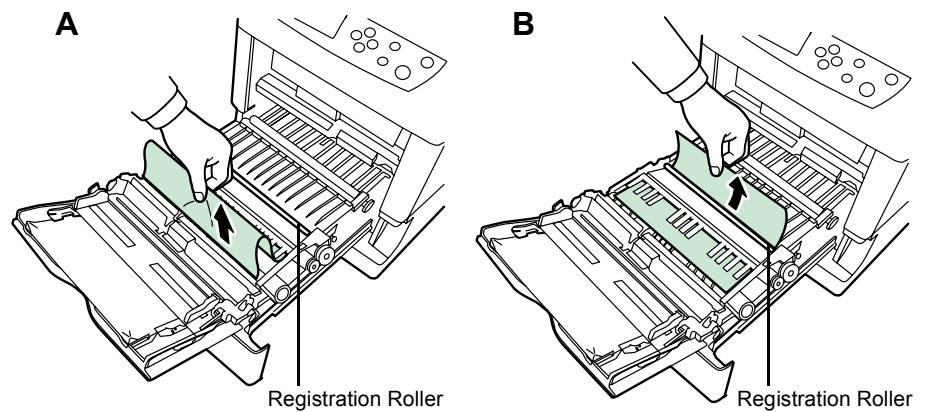

Figure 4-4

- 3** Push the paper transfer unit back in.

4.4.5 Jam at the Rear Cover

- 1 While pulling the green paper transfer unit release lever, pull out the paper transfer unit.

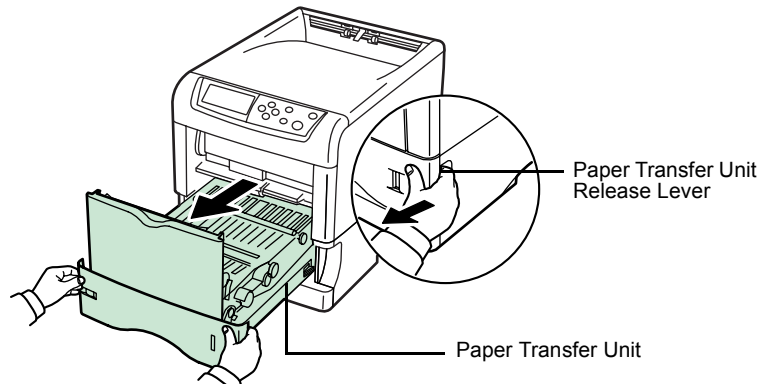

Figure 4-5

- 2 Open the rear cover and then the fuser cover, and remove the jammed paper.



Note

If the optional face-up tray is installed on the printer, remove that tray first before attempting to remove the jammed paper.

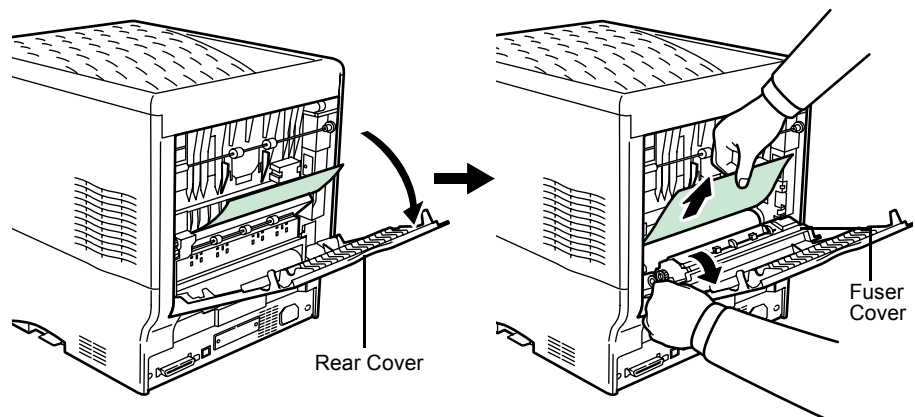

Figure 4-6



Caution

The fuser unit inside the printer is hot. Do not touch it with your hands as it may result in burn injury. Remove jammed paper carefully.

- 3 Push the paper transfer unit back in and close the fuser cover and rear cover.

4.4.6 Jam at the MP Tray

Paper is jammed at the MP tray. Remove the jammed paper using the procedure given below.

- 1** Remove the paper jammed at the MP tray.

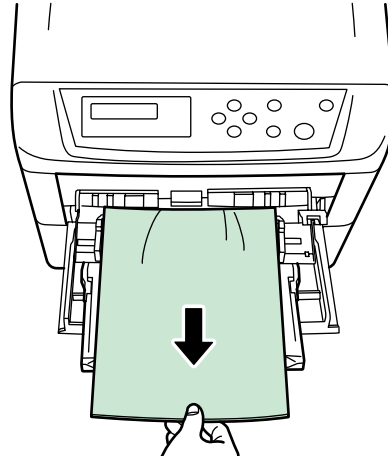

Figure 4-7

- 2** Open and close the paper transfer unit (the paper jam error will be reset).

4.4.7 Jam at the Optional Envelope Feeder

Paper is jammed at the optional envelope feeder. Remove the jammed paper using the same procedure as for a jam at the MP Tray. Then, open and close the paper transfer unit. For details, refer to the User's Manual for the envelope feeder.

4.4.8 Jam at the Optional Duplexer

Paper is jammed inside the rear cover of the optional duplexer or at the duplexer drawer. Refer to the Operation Guide for the duplexer and remove the jammed paper.

Chapter 5 Maintenance

This chapter describes basic maintenance tasks you can perform on the printer. You can replace the following component according to the printer's display:

- Toner Kits
- Waste Toner Box

Also, the following parts need periodic cleaning:

- Paper Transfer Unit
- Main Charger Units
- Advanced Beam Array Lenses

5.1 Toner Container Replacement

5.1.1 Frequency of toner container replacement

The life of the toner containers depends on the amount of toner required to accomplish your printing jobs. When 5 % coverage (a typical business document) of individual toner colors is assumed for A4 or letter size paper in landscape orientation:

- The black toner container lasts an average of 8,000 monochrome pages.
- The cyan, magenta, and yellow toner containers last an average of 8,000 color images.

You can print a status page to check how much toner remains in the toner container. For details, see [Chapter 3 Using the Operator Panel, section 3.3.2 Printing a Status Page on page 3-17](#). The Toner Gauge section on the status page shows a progress bar for each color, which roughly represents how much toner is left in the toner container.

Starter Toner Containers

The toner containers packed with the new printer are starter toner containers. The black starter toner container lasts an average of 4,000 monochrome pages. The cyan, magenta, and yellow starter toner containers last an average of 4,000 color images for each.

Toner Kits

It is strongly recommended to use the new Kyocera Mita Toner Kit supplied from Kyocera Mita to prevent printer troubles and ensure a long printer life.

The toner kits are supplied in 4 different colors: cyan, magenta, yellow and black.

A new toner kit for each color contains the following items:

- Toner Container
- Cleaning cloth
- Grid cleaner for main charger cleaning
- Plastic waste bags for old toner container and old waste toner box
- Waste toner box
- Installation Guide



Note

Do not remove the toner container from the carton until you are ready to install it in the printer.

5.1.2 Understanding Messages Requesting Toner Container Replacement

The printer displays messages for individual colors at two stages of toner usage. This message is automatically alternated with the other printer message (such as `Ready`):

- When the printer becomes low on toner, for example in the cyan container, the printer displays the message `Toner low C, M, Y, K` as the first caution. Note the replacement is not always necessary at this stage.
- If you ignore the above message and continue printing, the printer displays the message `Replace Toner` — just before the toner is used up. The toner container must be replaced immediately. Clean the separate charger wires, etc. After the cleaning is finished, however, the message does not automatically change to `Ready`. To restart printing, you must press the **GO** key and make the printer ready.

In either case, to replace the toner container, see [section 5.1 Toner Container Replacement on page 5-2](#).

5.1.3 Replacing the Toner Container



During toner container replacement, temporarily put storage media and computer supplies (such as floppy disks) away from around the toner container. This is to avoid damaging media by the magnetism of toner.

This section explains how to replace the toner containers. When replacing the toner container of any color, always replace the waste toner box at the same time. If this box is full, the printer may be damaged or contaminated by the waste toner that may spill over the box.



You do not have to turn printer power off before starting the replacement. Any data that may be under printing process in the printer will be deleted if you turn printer power off.

To replace the toner container, first make sure of the color of the toner container requiring replacement. In this example, it is assumed that you are replacing the black toner container.

- 1 Open the top cover.

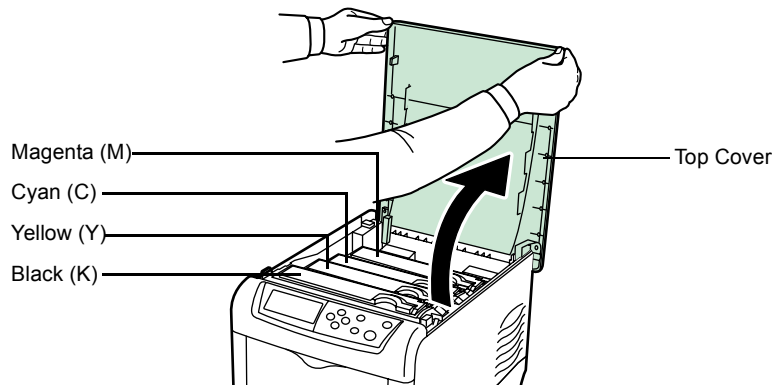

Figure 5-1

- 2 Pull the blue lock lever on the toner container forward towards the unlocked symbol (🔓).

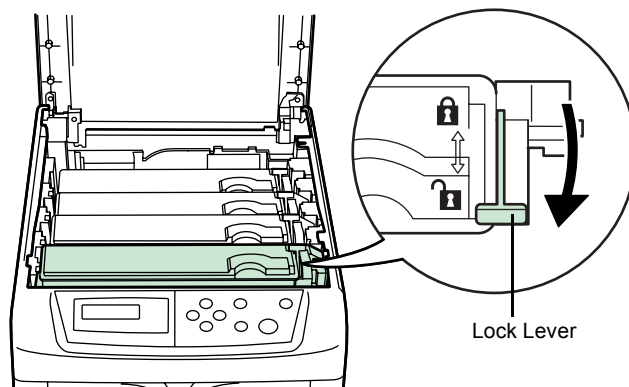

Figure 5-2

- Carefully remove the old toner container from the printer.

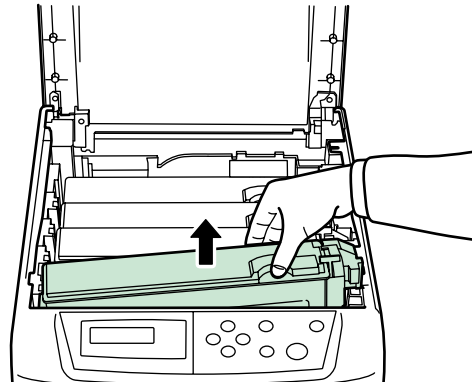

Figure 5-3

- Put the old toner container in the plastic bag (contained in the toner kit) and discard it later according to the local code or regulations for waste disposal.

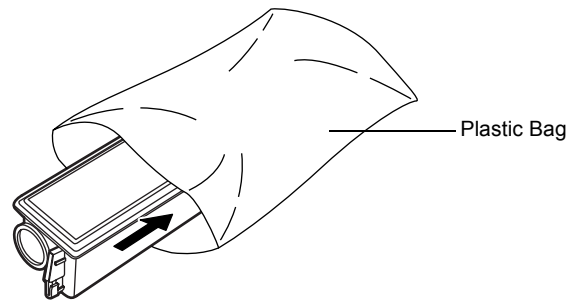

Figure 5-4

- Take the new toner container out of the toner kit.
- Shake the new toner container 5 or 6 times as shown in the figure in order to distribute the toner evenly inside the container.

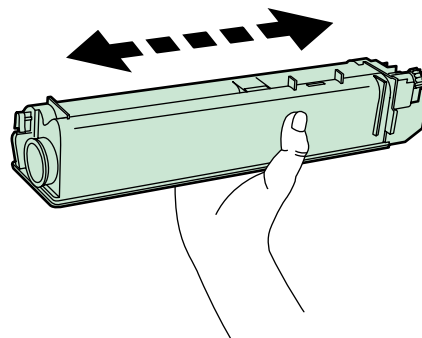

Figure 5-5

- 7 Set the new toner container in the printer as shown in the figure below.

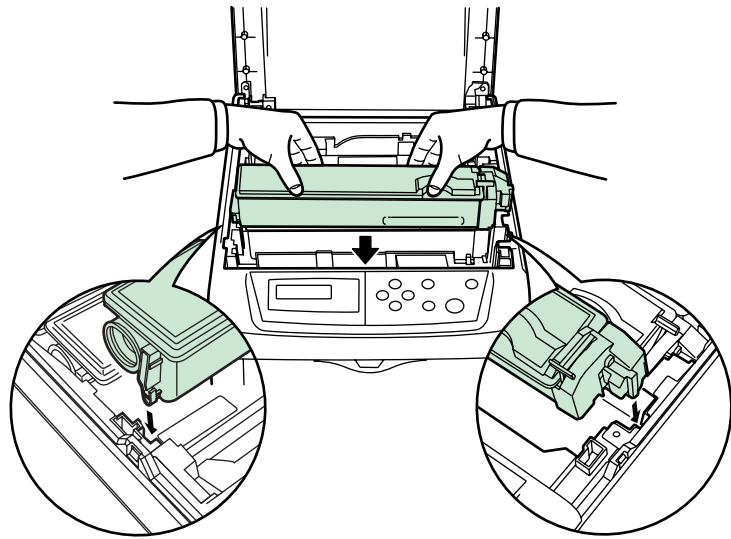

Figure 5-6

- 8 Push down on the top of the toner container to install it firmly in place.

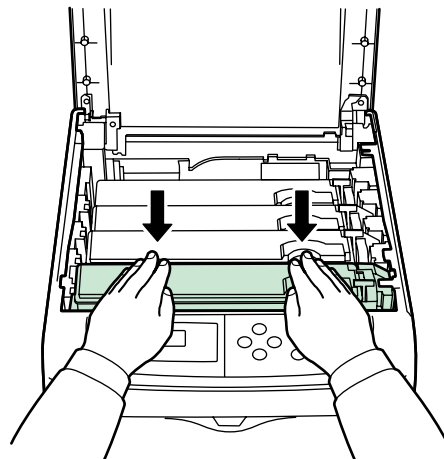



Figure 5-7

- 9** Pull the blue lock lever on the toner container back towards the locked symbol () as far as it will go.

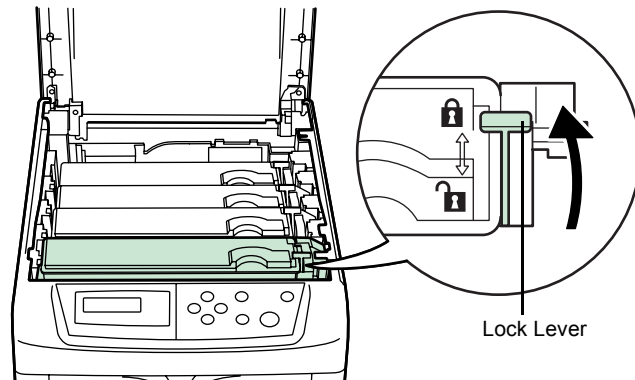

Figure 5-8

To replace the other color toner containers, use the same procedure above.

- 10** Close the top cover.

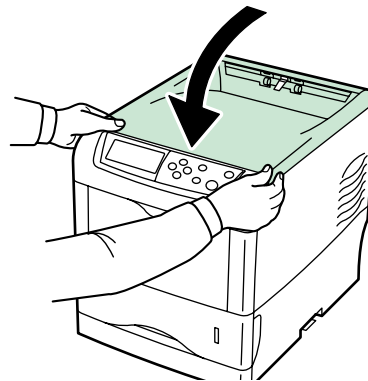

Figure 5-9

Proceed to the next section and replace the waste toner box.

5.2 Replacing the Waste Toner Box

Replace the waste toner box each time you replace the toner container. A new waste toner box is included with the toner kit. The printer will not operate without replacing the waste toner box.

- 1 Open the left cover.

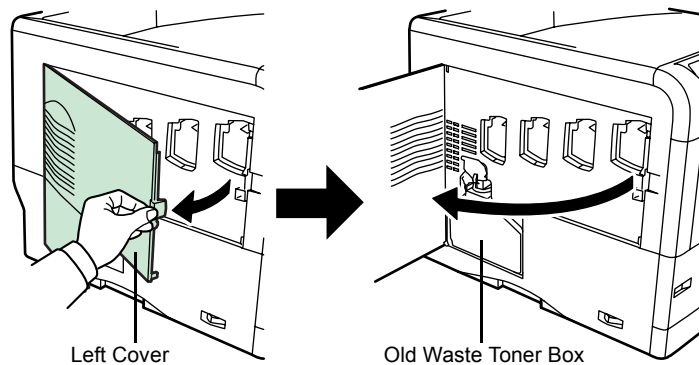

Figure 5-10

- 2 While holding the waste toner box, press the lock lever and then gently remove the waste toner box.

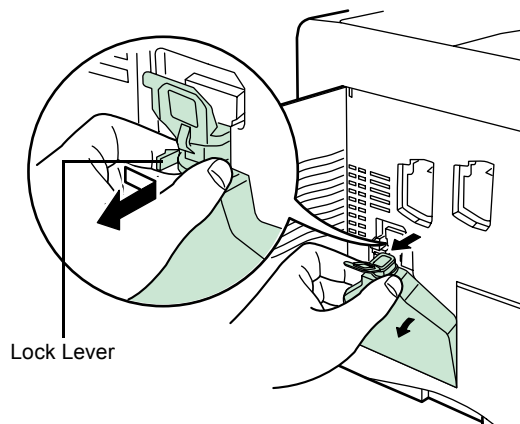

Figure 5-11



Note

Remove the waste toner box as gently as possible so as not to scatter the toner inside. Do not let the opening of the waste toner box face downward.

- 3** Close the cap to the old waste toner box after removing the box from the printer.

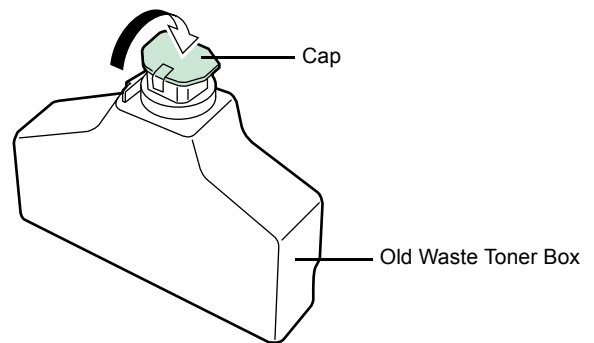

Figure 5-12

- 4** To prevent toner from spilling, put the old waste toner box in the plastic bag (contained in the toner kit) and discard it later according to the local code or regulations for waste disposal.

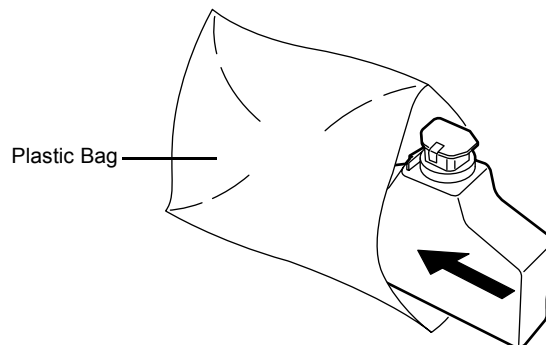

Figure 5-13

- 5** Open the cap of the new waste toner box.

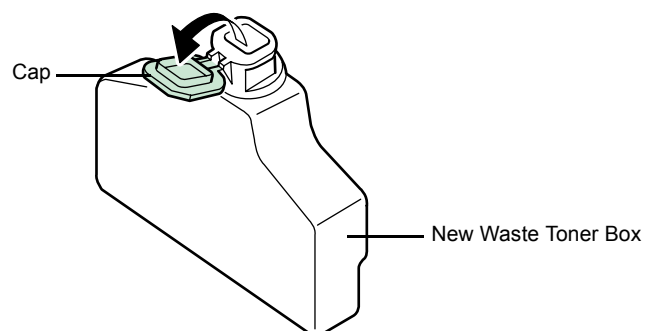

Figure 5-14

- 6 Insert the new waste toner box as shown in the figure below. When the box is set correctly, it will snap into place.

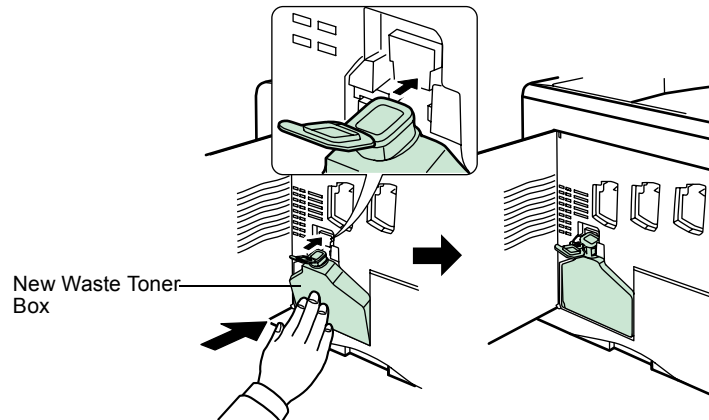

Figure 5-15

- 7 Make sure that the waste toner box is correctly inserted and close the left cover.

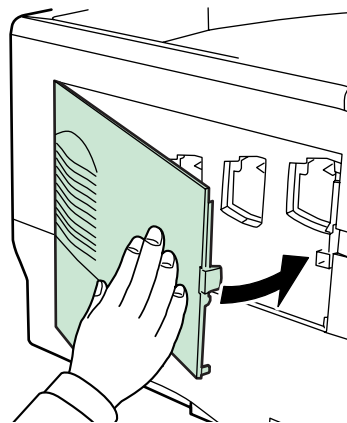

Figure 5-16

After replacing the toner containers and the waste toner box, clean the main charger units and the paper transfer unit. For instructions, see [section 5.3 Cleaning the Printer on page 5-11](#).

5.3 Cleaning the Printer

As discussed earlier, the following parts must be cleaned each time the toner container and waste toner box are replaced:

- Main charger wire
- Main charger grid
- Registration roller

In addition to this, it is recommended that the main charger wire and registration roller are cleaned periodically at least once a month.

If lines, etc., appear on printed copies, the printouts appear dirty, or faint or blurred printouts are produced, clean the advanced beam array lenses.

5.3.1 Cleaning the Main Charger Unit

The main charger units need to be cleaned periodically as they get contaminated with dioxide after long usage. Each main charger unit is comprised of two main parts — the wire and the grid — which should be separately as explained below.

There are 4 main charger units, one for each toner container. When performing the cleaning procedure, be sure to clean the main charger unit that corresponds to color of the toner container that was replaced. The following example explains the procedure to clean the main charger unit for the black toner container.

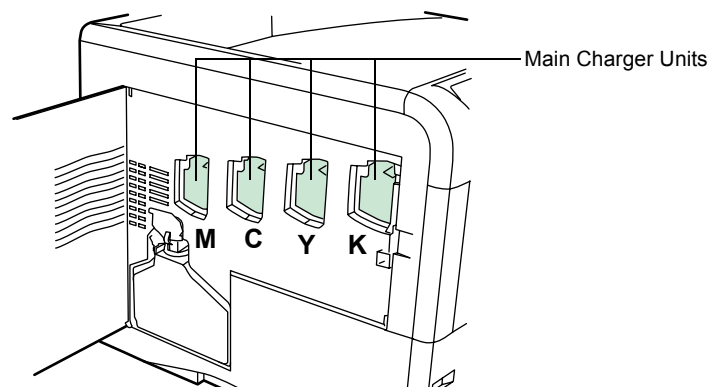

Figure 5-17

- 1 Open the left cover.

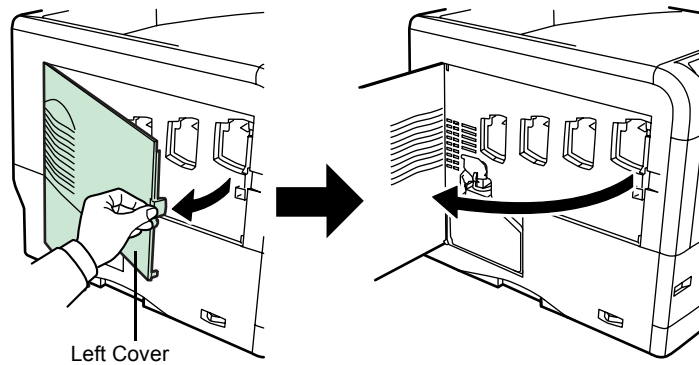

Figure 5-18

- 2 First clean the main charger wire. Grasp the green wire cleaner knob. Gently pull the wire cleaner knob out and push it back in. Repeat this 2 to 3 times. After cleaning, make sure you restore the wire cleaner knob to its home position.

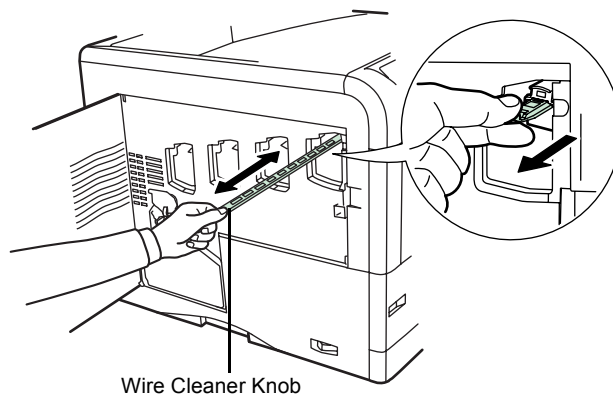

Figure 5-19



Note

If the wire cleaner knob is not restored to its home position, a band will print along the length of the page.

- 3** Next, clean the main charger grid. Take the grid cleaner out of the toner kit. Take the grid cleaner out of the protective bag and remove the cap.

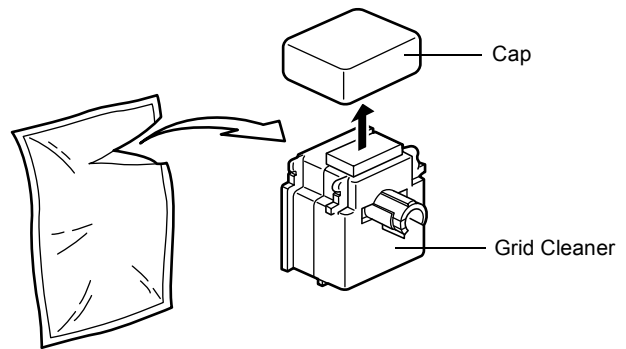

Figure 5-20



Note

The pad of the grid cleaner contains water. Clean the grid quickly so that the pad may not dry off.

- 4** Lift up slightly on the main charger unit and pull it out a short distance as shown in the figure below.

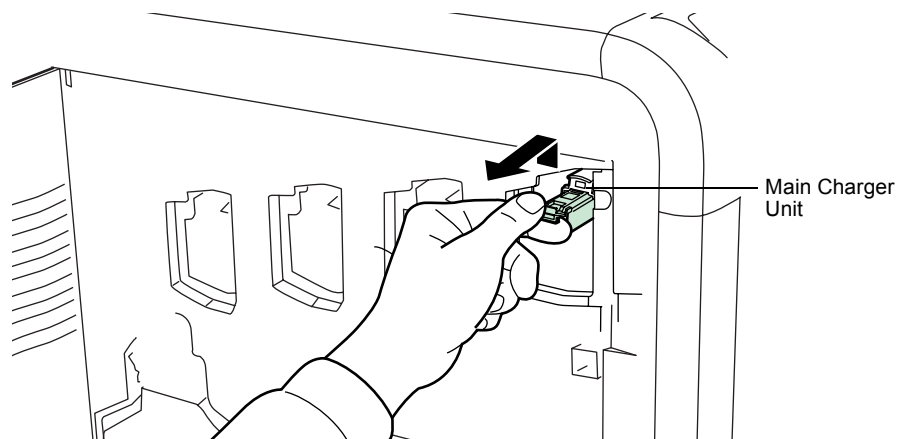

Figure 5-21

- 5** Attach the grid cleaner to the printer with the pad facing up.

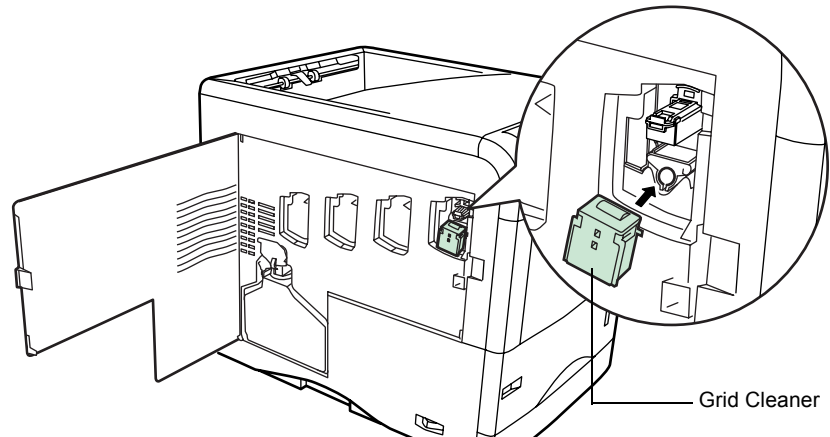

Figure 5-22

- 6** Gently pull the main charge handle out and push it back in. Repeat this 2 to 3 times. These movements clean the grid. After cleaning, make sure you restore the main charge unit to its home position.

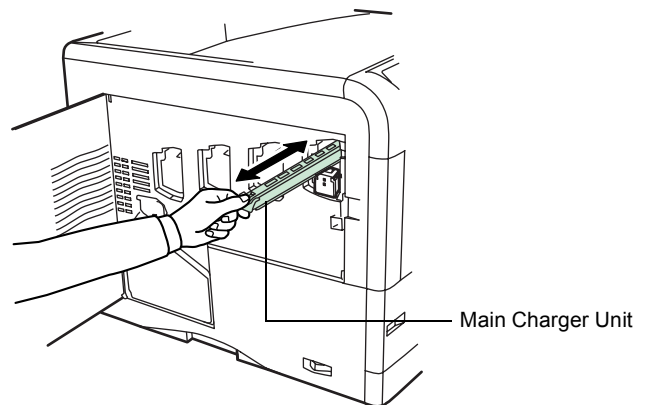

Figure 5-23



Note

If the main charge unit is not restored to its home position, the corresponding color will be printed over the whole page.

- 7 Remove the grid cleaner from the printer and discard it. The grid cleaner cannot be reused.

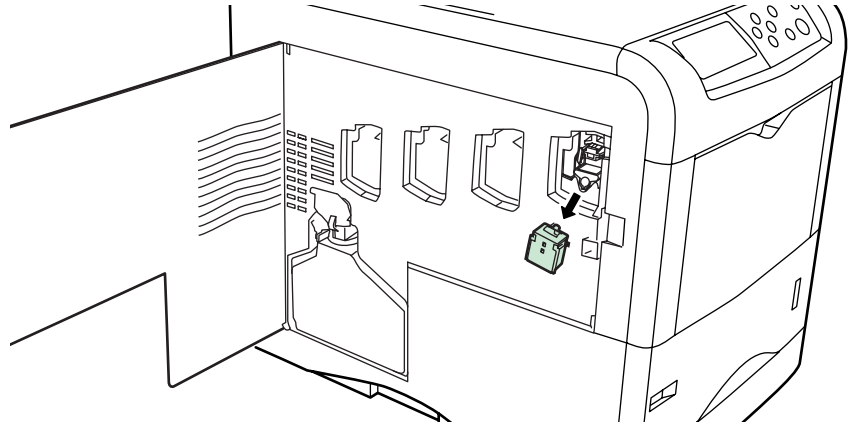

Figure 5-24

Use the same procedure to clean the main charger units for the other toner containers.

- 8 Close the left cover.

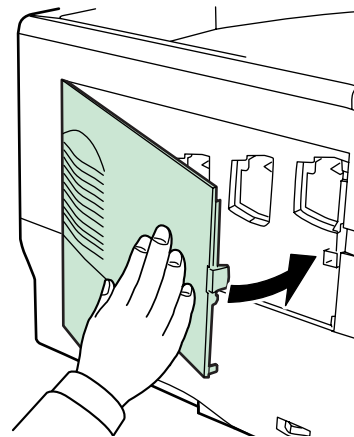

Figure 5-25

5.3.2 Cleaning the Paper Transfer Unit

Print problems such as soiling of the reverse side of printed pages may occur if the paper transfer unit becomes dirty. To clean the paper transfer unit, the following tool must be used:

- Cleaning cloth (included in the toner kit)

Clean the paper transfer unit according to the procedure that follows:

- 1** While pulling the green paper transfer unit release lever, pull out the paper transfer unit.

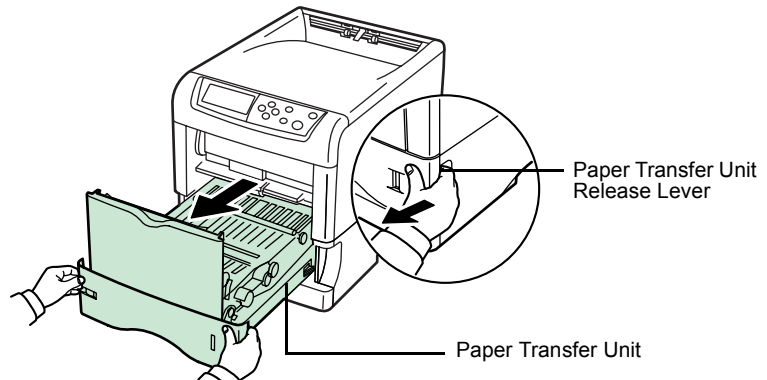

Figure 5-26

- 2** Wipe away the paper dust on the registration roller and the paper ramp using the wiper cloth included in the toner kit.

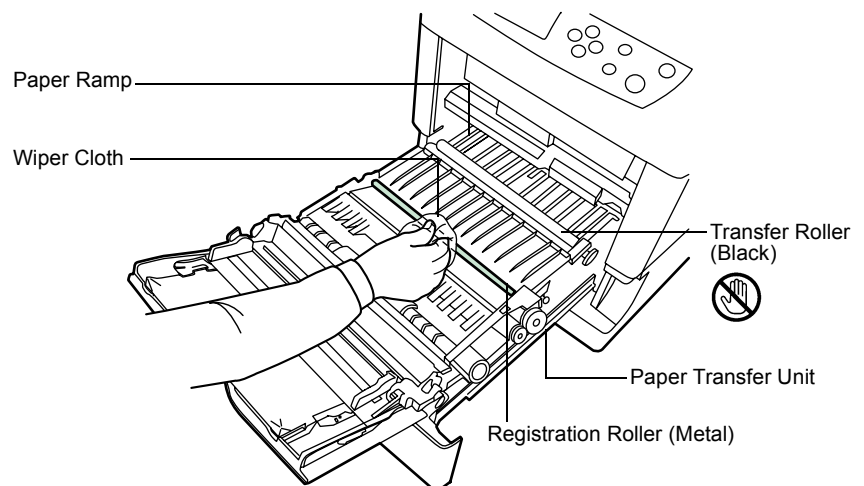

Figure 5-27



Note

Be careful not to touch the black transfer roller during cleaning as this may adversely affect print quality.

- 3** Push the paper transfer unit back in completely.

5.3.3 Cleaning the Advanced Beam Array Lenses

If lines, etc., appear on printed copies, the printouts appear dirty, or faint or blurred printouts are produced, clean the advanced beam array lenses.

There is 1 lens on the main charger unit of each toner container. The following example explains the procedure to clean the lens on the main charger unit of the black toner container.

- 1 Open the left cover.

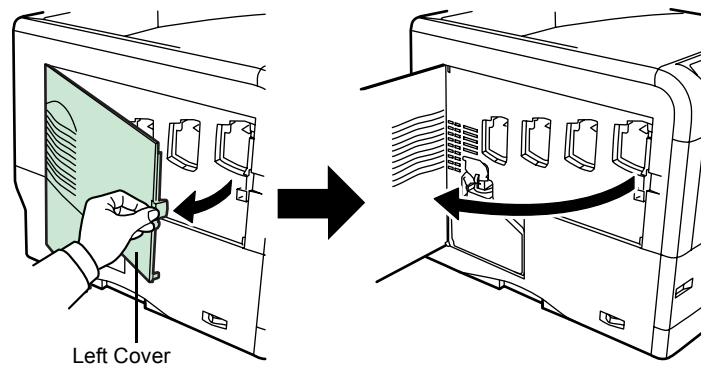

Figure 5-28

- 2 Grasp the tab of the green lens cleaner knob. Gently pull the lens cleaner knob out and push it back in. Repeat this 2 times.

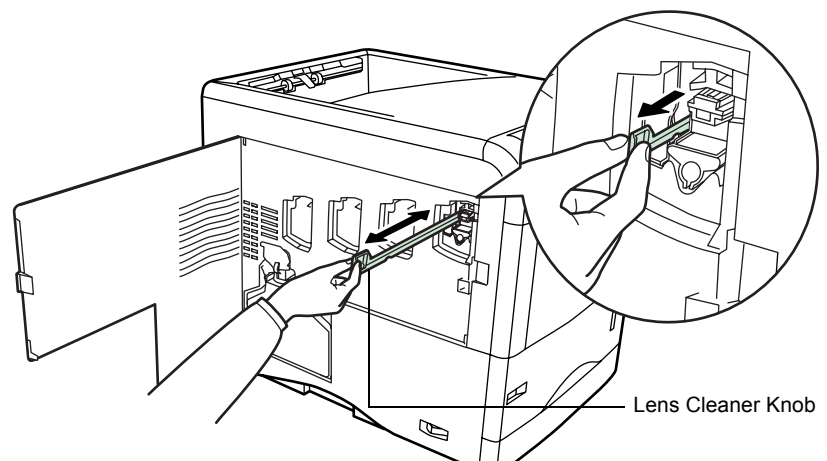

Figure 5-29

- 3** Push the lens cleaner knob back in completely. After cleaning, make sure you restore the lens cleaner knob to its home position.

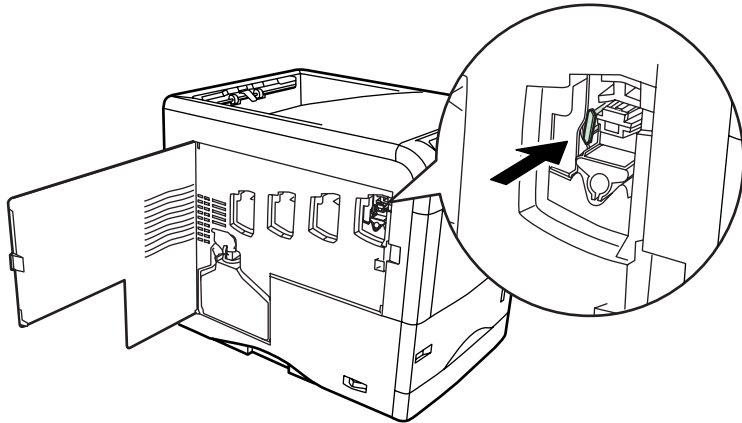

Figure 5-30



Note

If the lens cleaner knob is not restored to its home position, the corresponding color will be printed over the whole page.

Use the same procedure to clean the lenses on the main charger unit of the other toner containers.

- 4** Once you are finished cleaning all 4 lenses, close the left cover.

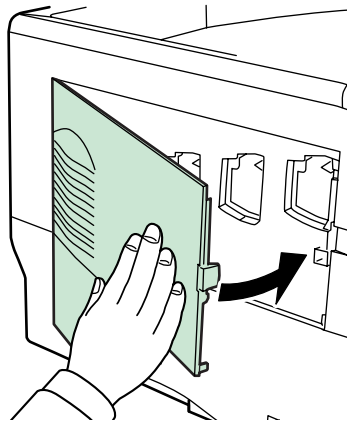

Figure 5-31

Appendix A Options

Your printer can be installed with various options indicated in this appendix.
You can select the options that will satisfy your printing requirements.
For availability of the options, consult your Kyocera Mita dealer.

A.1 Options

The FS-C5016N printer has the following options available. For instructions on installing individual options, refer to the documentation included with the option. Some options are explained in the following sections.

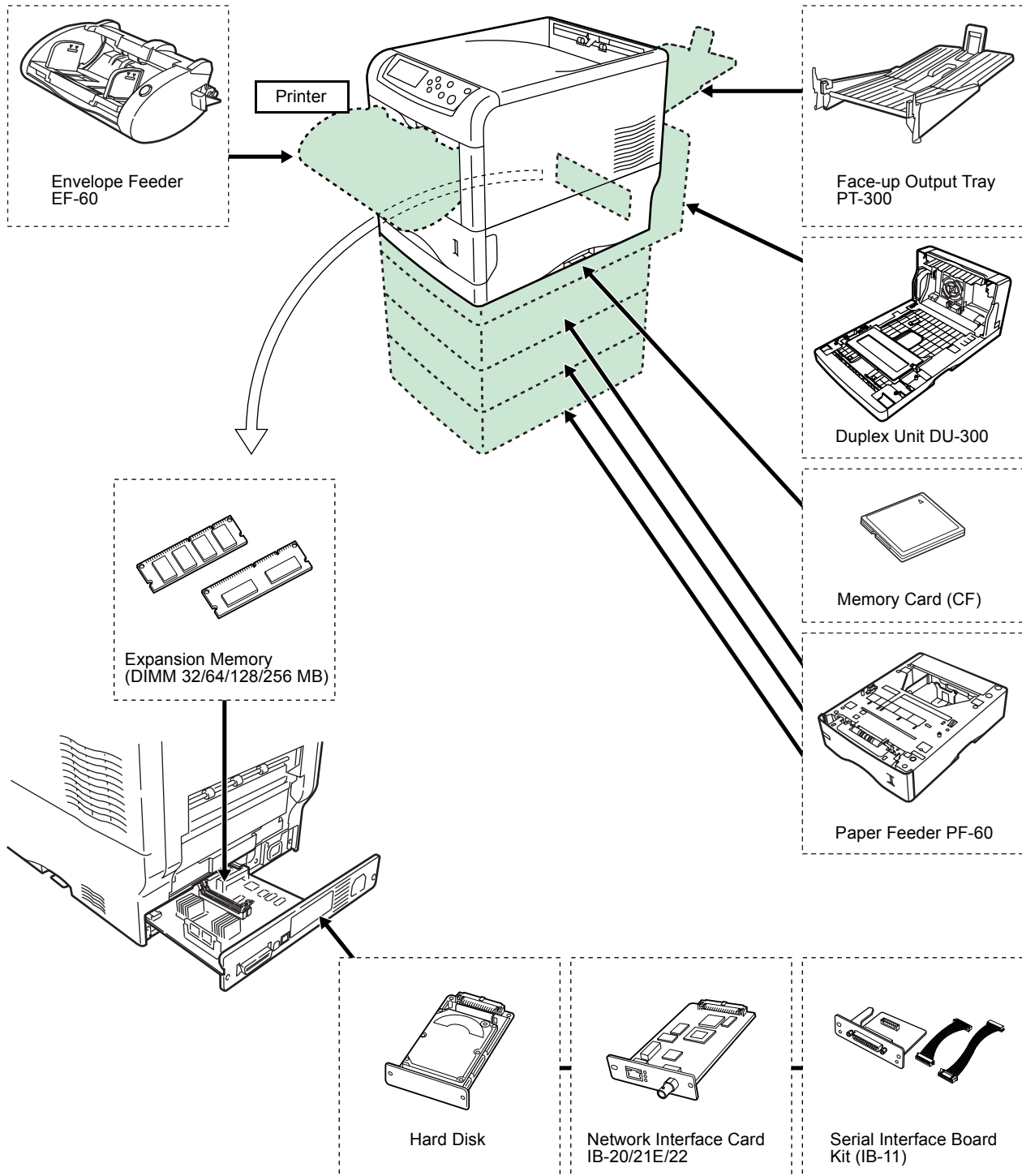

Figure A-1

A.2 Expansion Memory Modules

To expand the printer memory for more complex print jobs and faster print speed, you can plug in optional memory modules (dual in line memory modules) in two memory slots provided on the printer main controller board. You can select additional memory modules from 32, 64, 128, or 256 MB (the maximum memory size is 608 MB, including the base 96 MB memory).



Note

Only an authorized Kyocera Mita dealer should install the expansion memory. Kyocera Mita shall not be liable for any damages caused by improper installation of expansion memory.

Precautions on handling the printer's main controller board and memory modules

- To protect electronic parts, discharge static electricity from your body by touching a water pipe (faucet) or other large metal object before handling the memory modules. Or, wear an antistatic wrist strap, if possible, when you install the memory modules.
- Always hold the main controller board or a memory module by its edges as shown below to avoid damaging electronic parts.

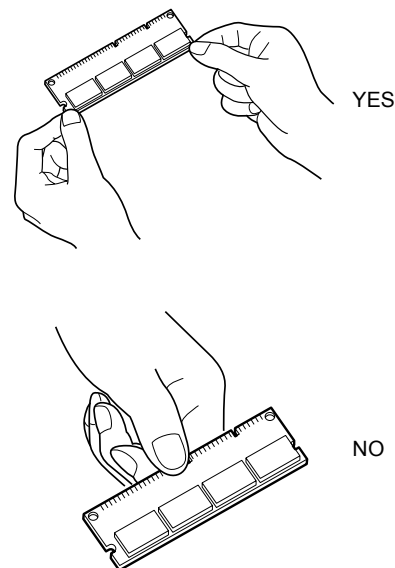

Figure A-2

A.2.1 Installing the Memory Modules

- 1** Power off the printer and unplug the printer power cord.
- 2** Unscrew two screws at the back of the main controller board.

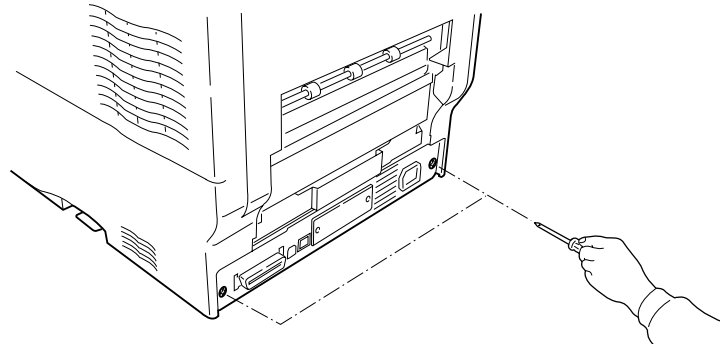

Figure A-3

- 3** Pull out the main controller board gently.

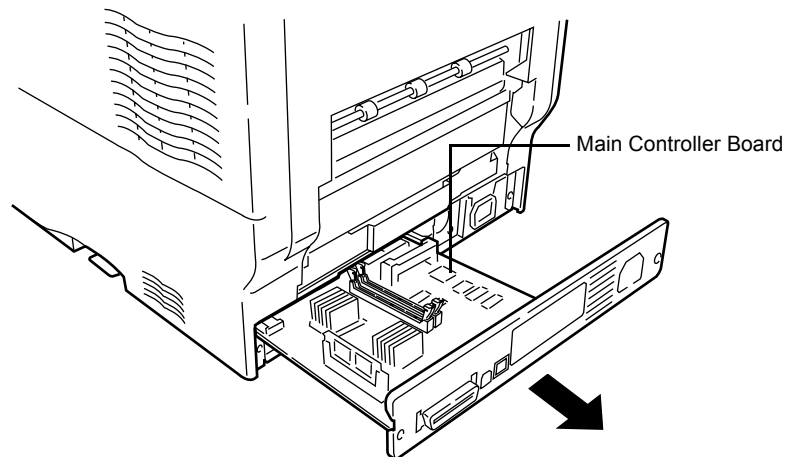

Figure A-4

- 4** Push out the clamps on both ends of the memory socket on the main controller board.

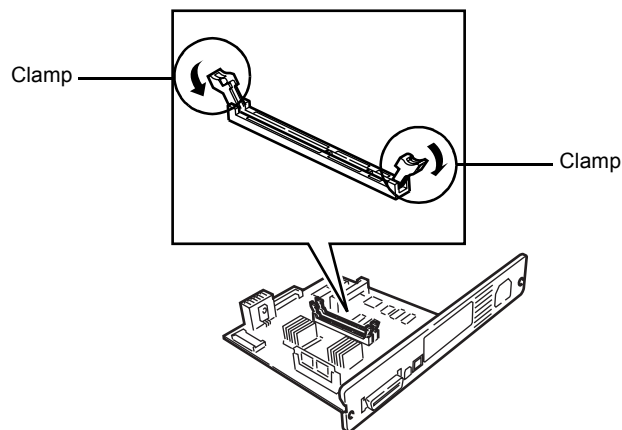

Figure A-5

- 5** Remove the memory module from its package. Aligning the cutouts of the memory module with the matching keys of the socket, carefully plug the memory module into the memory socket until it clicks in place.

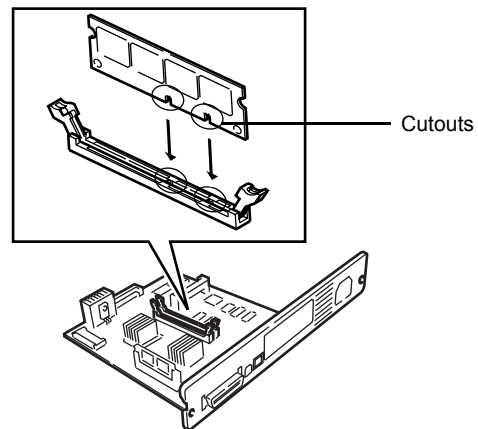

Figure A-6

- 6** Push down the two socket clamps to secure the memory modules.

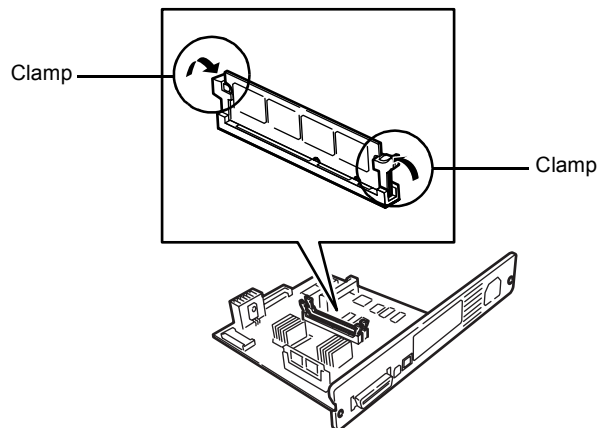

Figure A-7

- 7** After you finish installing the memory modules, reinstall the main controller board and fasten it with screws.

Removing a Memory Module

To remove a memory module, remove the main controller board, then carefully push out the two socket clamps. Ease the memory module out of the socket to remove.

Testing the expanded memory

To verify that the memory modules are working properly, test them by printing a status page. To print a status page:

- 1** Make sure the printer is switched off. Plug in the printer power cord into an AC outlet and power on the printer.
- 2** Wait until the printer becomes `Ready`. When ready, press the **MENU** key.
- 3** Press the ∇ key repeatedly until the message display shows `Print Status Page`.
- 4** Press the **ENTER** key twice. A status page is printed.

Check the **Memory** field in the upper right area. It shows information about the memory modules installed in memory slots 1 and 2. If you see an increase in the total memory size, the installation is successful. (Note that the printer is shipped with 128 MB of base memory.)

A.3 General Description of Options

A.3.1 Memory Card

The printer is equipped with a slot for a memory card with the maximum size of 256 MB. A memory card is useful for storing fonts, macros, and overlays. You can use the **IC Link for Windows** utility to download fonts, etc., to a flash memory card. This software is included in the CD-ROM supplied with the printer.

Reading Font from the Memory Card

Once inserted in the printer's slot, the contents of the memory card can be read from the control panel or automatically when you power on or reset the printer. To manually read data in the memory card, see [Chapter 3 Using the Operator Panel, section 3.9.1 Using the Memory Card on page 3-59](#).



Before inserting a memory card in the printer, make sure that the printer is switched off.

Insert the memory card in the memory card slot.

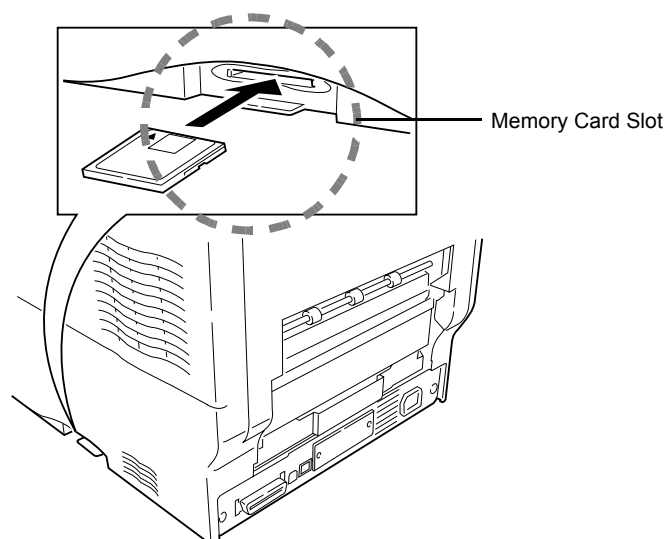

Figure A-8

A.3.2 PF-60 Paper Feeder

The PF-60 paper feeder allows you to add 3 more paper cassettes to the bottom of the printer for continuous feeding of a large volume of paper. Each paper cassette can hold up to approximately 500 sheets of ISO A4, ISO A5, JIS B5, letter, and legal size (80 g/m²) paper. This feeder is attached at the bottom of the printer as shown below.

For detailed information on installing the paper feeder, see the manual supplied with the paper feeder.

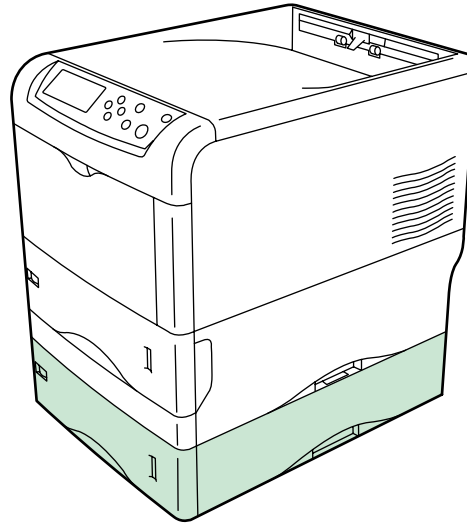

Figure A-9

A.3.3 DU-300 Duplex Unit

The DU-300 duplex unit is attached to the bottom of the printer and allows you to print onto both sides of the paper. Printing on both sides can be performed using ISO A4, ISO A5, JIS B5, letter, and legal sized paper.

For detailed information on installing the duplex unit, see the manual supplied with the duplex unit.

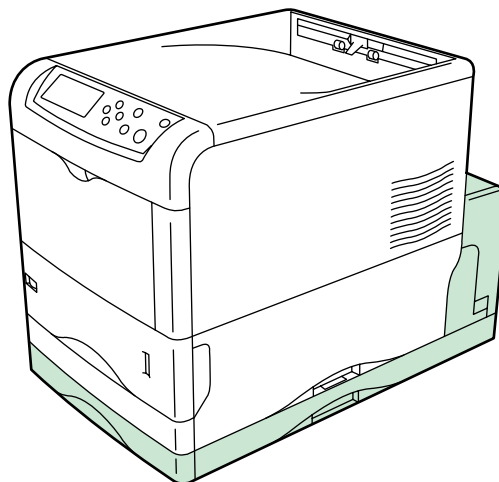

Figure A-10

A.3.4 PT-300 Face-up Output Tray

Use the face-up output tray when you wish paper to be stacked with the printed side facing up (reverse order), or when you are printing on envelopes, postcards, transparencies, or thick paper.

- 1 Install the paper stopper according to the size of paper to be used.

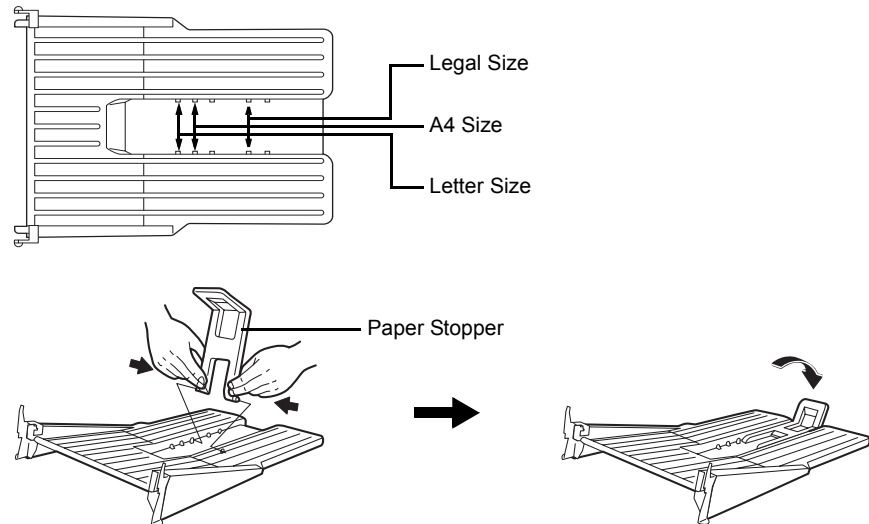
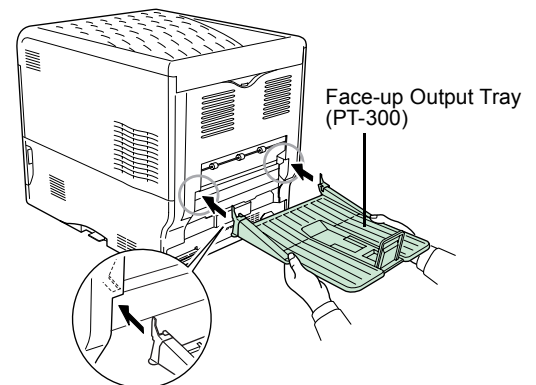

Figure A-11

- 2 Install the face-up output tray on the rear of the printer.

When installing directly to the printer



If a duplexer has been installed to the printer

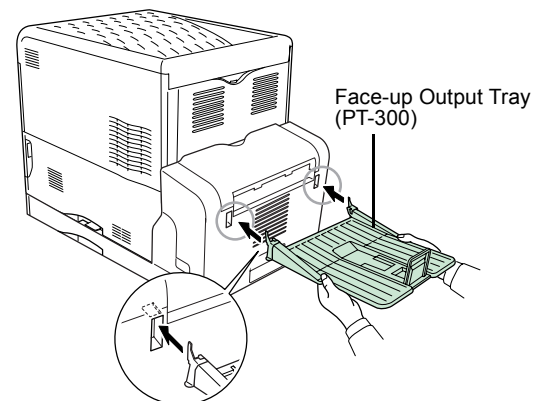

Figure A-12

A.3.5 Hard Disk

The hard disk is used for saving print data. This is advantageous when printing multiple sets of copies, as high-speed printing is possible using the electronic sorting function. The hard disk is further required in order to use the e-MPS function. You can use the **KM-NET Printer Disk Manager** utility to keep track of the stored data. This software is included in the CD-ROM supplied with the printer.

The hard disk must be installed in the option interface slot that is located at the back of the printer as shown below.

The hard disk must be formatted before the initial use. To format the hard disk, use the printer operator panel or the **KM-NET Printer Disk Manager**. Before you install the hard disk in the printer, power off the printer and unplug the power cord.

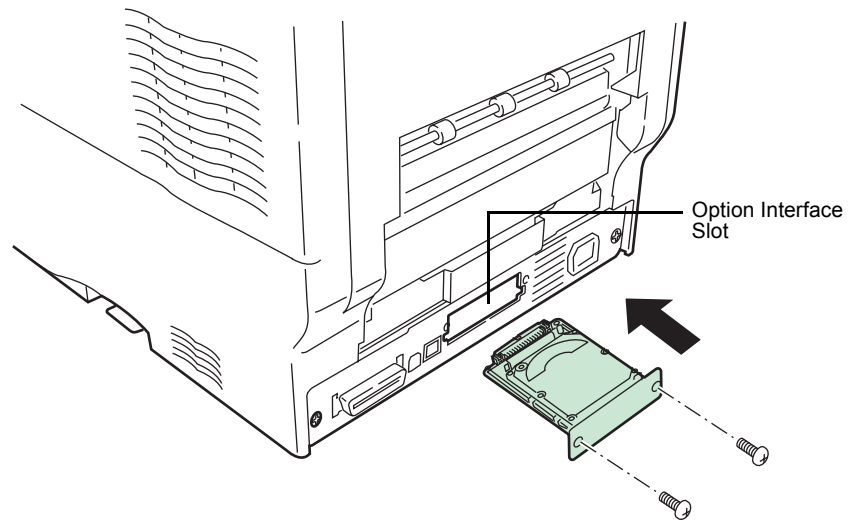

Figure A-13

A.3.6 IB-20/IB-21E/IB-22 Network Interface Cards

Along with the standard for the network interface on the printer, the network interface card supports TCP/IP, IPX/SPX, NetBEUI and EtherTalk protocols, so that the printer can be used on network environments including Windows, Macintosh, UNIX, NetWare, etc. The network interface card must be installed in the option interface slot that is located at the back of the printer as shown below.

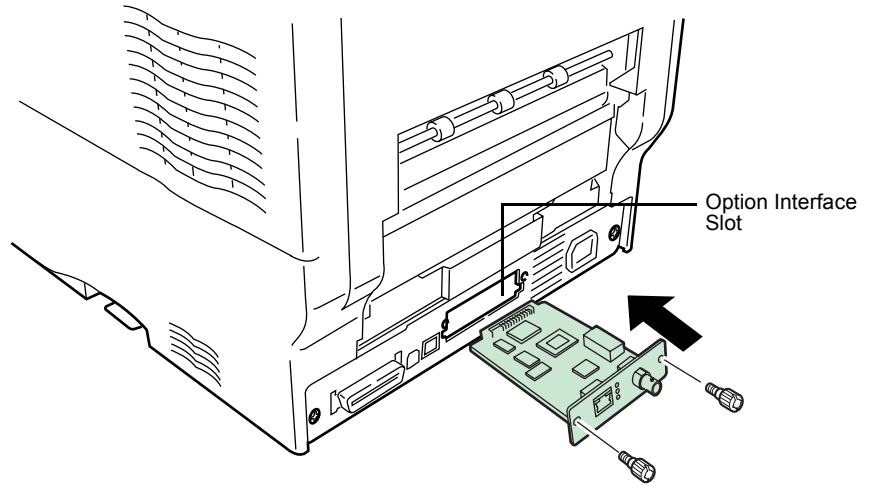

Figure A-14

Network interface card	Network connections
IB-20	10Base-T/100Base-TX/10Base-2
IB-21E	10Base-T/100Base-TX
IB-22	IEEE802.11b (Wireless)

Table A-1

Appendix B Computer Interface

This appendix explains the signals used in the printer's parallel, USB, and serial (option) interfaces. It also lists pin assignments, signal functions, timings, connector specifications, and voltage levels. For details on the network interface, refer to the IB-21E/IB-22 User's Manual contained on the CD-ROM that is supplied with the printer.

This appendix explains the following topics:

- Parallel Interface
- USB Interface
- Serial Interface (Option)

B.1 Parallel Interface

B.1.1 Communication Modes

The printer provides high-speed data transmission on a parallel interface. You can select the parallel interface communication mode from the operation panel. To change communication mode, see [Chapter 3 Using the Operator Panel, section 3.5.1 Changing Parallel Interface Mode on page 3-34](#).



Note

Use a parallel interface cable that complies with the IEEE 1284 standard.

You can choose from four communication modes:

Communication Mode	Reception	Transmission
Auto (default)	High-speed/ECP	Nibble/ECP
Nibble	High-speed	Nibble
High-speed	High-speed	—
Normal	Normal	—

Table B-1

B.1.2 Interface Signals

Table shows the connector pins and corresponding input and output signals of the parallel interface. Explanation of each signal is also given in the table.

The description in [] indicates signal names in Auto mode and Nibble (high) mode (IEEE 1284-compliant). In Auto and Nibble modes, these signals are bidirectional.

Pin	In or out	Signal	Description
1	In	Strobe [†] [nStrobe]	A negative-going-strobe pulse causes the printer to read and latch the data on the Data 0 [1] to Data 7 [8] signal lines.
2	In	Data 0 [Data 1]	These eight signals form one byte of data sent from host computer to printer. Data 7 [8] is the most significant bit.
3	In	Data 1 [Data 2]	
4	In	Data 2 [Data 3]	
5	In	Data 3 [Data 4]	
6	In	Data 4 [Data 5]	
7	In	Data 5 [Data 6]	
8	In	Data 6 [Data 7]	
9	In	Data 7 [Data 8]	
10	Out	Acknowledge [†] [nAck]	This negative-going pulse acknowledges the previous character received.
11	Out	Busy [Busy]	When this signal is high, the printer is busy. When it is low, the printer is able to receive more data.
12	Out	Paper Empty [PError]	This signal goes high when the printer runs out of paper. ^{††}
13	Out	Online (Select) [Select]	This signal goes high when the printer is online and low when the printer is offline. The signal goes low when you press the GO key to make the printer go off line. ^{††}
14	In	— [nAutoFd]	Ignored
15	—	—	Not used
16	—	0 V DC	
17	—	Chassis Ground	
18	—	+5 V DC	This pin is used for the printer's +5 V DC power supply (+5±0.5 V, 400 mA maximum, with fuse)
19	—	Ground return	
20	—	Ground return	
21	—	Ground return	
22	—	Ground return	
23	—	Ground return	
24	—	Ground return	
25	—	Ground return	
26	—	Ground return	
27	—	Ground return	
28	—	Ground return	
29	—	Ground return	

Table B-2

Pin	In or out	Signal	Description
30	—	Ground return	
31	In	— [nInit]	Ignored
32	Out	Error [†] [nFault]	When the high-speed parallel line control is on, this line returns an error status. ^{††}
33	—	—	Not used
34	—	—	Not used
35	Out	Power Ready	This signal goes high when the printer is powered on.
36	In	Select In [nSelect In]	When this line is high, IEEE1284 mode is enabled.

Table B-2

[†] Indicates signals that are low active.

^{††} The Paper Empty, Online, and Error signals work only after you have enabled them using the O2 parameter of the FRPO command.

B.2 USB Interface

This printer supports the Full-Speed USB 2.0. USB (Universal Serial Bus) interface specifications and interface signals are as follows.

B.2.1 Specifications

Basic specification

Complies with the Full-Speed USB 2.0.

Connectors

Printer: B-type receptacle (female) with upstream port

Cable: B-type plug (male)

Cable

Use a shielded cable that complies with USB 2.0 and not longer than 5 meters (16 feet).

Transfer Mode

Full speed (max. 12 Mbps)

Power Control

Self-power device

B.2.2 Interface Signals

USB Connector Pin Assignment

Pin	Signal	Description
1	Vbus	Power supply (+5 V)
2	D-	Data transmission
3	D+	Data transmission
4	GND	Signal ground
Shell		Shield

Table B-3

B.3 Serial Interface (Option)

Installing the optional serial interface board kit (IB-11) in the printer enables connection to a computer with an RS-232C standard serial interface.

B.3.1 Interface Signals

Table B-4 below shows the pins and corresponding input and output signals of the RS-232C interface connector.

Pin	In or out	Signal	Description
1	—	FG	Frame Ground. This pin is connected directly to the printer frame.
2	Out	TXD	Transmit Data. This pin is used to output asynchronous data sent from the printer to the computer. This signal is often used in handshaking.
3	In	RXD	Receive Data. This pin is used to input serial asynchronous data sent from the computer to the printer.
4	Out	RTS	Request To Send. This output is always high (above 3 volts).
5	In	CTS	Clear To Send. Not used.
6	In	DSR	Data Set Ready. Not used.
7	—	SG	Signal Ground. This pin is used to establish a common reference level for the voltages of all signals other than Frame Ground.
20	Out	DTR	Data Terminal Ready. This pin is used to notify the status of the printer buffer (i.e., nearly full or nearly empty) when handshaking is used. The pin goes high (above 3 volts) when the buffer is able to accept more data.

Table B-4

B.3.2 Interface voltage levels

The voltage levels of the interface signals conform to EIA RS-232C specifications. The voltage level of SPACE is 3 to 15 volts. The voltage level of MARK is -3 to -15 volts. Voltages between -3 and 3 volts are undefined.

B.4 RS-232C Protocol

B.4.1 Parameters of the RS-232C Protocol

A protocol is a set of rules followed by various devices to send or receive data. The parameters of the RS-232C protocol are stored in the battery-powered memory of the printer. You can verify these parameters on the status printout as marked by the following identifications:

- H1: Baud rate
- H2: Number of data bits
- H3: Number of stop bits
- H4: Parity
- H5: Protocol logic
- H6: Buffer-nearly-full threshold
- H7: Buffer nearly-empty threshold
- H8: Received data buffer size

The parameters can be changed from the printer operator panel. To change the value for the serial interface parameters, see [Chapter 3 Using the Operator Panel, section 3.5.2 Changing Serial Interface Parameters on page 3-35](#).

This following section outlines the parameters and their values you can select on the operator panel:

H1: Baud rate

Parameter value	Baud rate
12	1200
24	2400
48	4800
96	9600
19	19200
38	38400
57	57600
11	115200

The factory setting is 96 (9600 baud).

H2: Number of data bits

7 or 8. The factory setting is 8.

H3: Number of stop bits

1 or 2. The factory setting is 1.

H4: Parity

Parameter value	Meaning
0	None
1	Odd
2	Even
3	Ignored

The factory setting is 0 (none).

H5: Protocol logic

Parameter value	Meaning
0	Combination of DTR (positive logic) and XON/XOFF
1	DTR (positive logic)
2	DTR (negative logic)
3	XON/XOFF
4	ETX/ACK

The factory setting is 0.

H6: Buffer nearly-full threshold

A percentage value from 0 to 99. The factory setting is 90.

H7: Buffer nearly-empty threshold

A percentage value from 0 to 99. The factory setting is 70. The factory settings of the buffer nearly-full and nearly-empty thresholds (H6 and H7) are subject to change without notice.

The difference between the nearly-full and nearly-empty thresholds allows the computer to send a fairly large amount of data in a continuous stream.

H8: Received data buffer size

The input buffer size is specified in increments of 100 kB. The factory setting is 5 (500 kB).

B.4.2 PRESCRIBE FRPO D0 Command

The PRESCRIBE FRPO D0 command is provided to allow manipulating XON/XOFF when an error has occurred on the serial interface. *Table B-5* summarizes the error status corresponding to different D0 values.

Timing of XON transfer to host while Ready or Waiting	Serial interface error	
	error not handled	error handled
XON sent every 3-5 seconds	D0=0 (default)	D0=1
XON not sent	D0=10	D0=11

Table B-5

B.5 RS-232C Cable Connection

B.5.1 Preparing an RS-232C Cable

After you procure an RS-232C cable, check its wiring against the pin assignments shown in page [section B.1.2 Interface Signals on page B-3](#). If you have an IBM communications adapter cable type 1502067, use the procedure below to solder the wiring at the end (printer side) of the cable:

- 1** Unscrew the plastic cover at the end (printer side) of the cable.
- 2** A bare shield wire is provided for each wire in the cable. Solder all shield wires together into a single bundle.
- 3** Connect the bundled shield wires to the connector metal face using a piece of flat cable about 3 mm wide and 15 mm long. Make sure that the soldered connections are secure.
- 4** Unsolder wires 2 and 3, then resolder them in a crossover configuration. In other words, solder wire 2 to pin 3 and wire 3 to pin 2. Cover the solder joints with a thermofit tube.
- 5** Cut wires 4, 5, 6, and 20.
- 6** Solder wires 5 and 6 together and connect them to pin 20. Cover the solder joints with a thermofit tube. Leave wire 4 unconnected.
- 7** Tape all remaining loose ends together, or seal them with a thermofit tube.
- 8** Screw the plastic cover back on the cable end.

B.5.2 Connecting the Printer to the Computer

Make sure that both computer and printer are powered off.

- 1** Discharge static electricity from your body by touching a metal object such as a doorknob.
- 2** Plug the end (printer side) of the RS-232C cable into the printer's serial interface connector and screw it on securely.
- 3** Plug the other end of the cable into the computer's serial interface connector.
- 4** Power on the printer.
- 5** The printer's parameters are set at the factory as follows:

Baud rate = 9600 bps, data bits (character length) = 8, stop bits = 1, parity = none

The two RS-232C protocols are XON/XOFF and DTR. The printer executes both of these protocols simultaneously, using positive logic for DTR.

If you are not sure about the printer's current parameter settings, reset them to the values shown above (i.e., baud rate = 9600 bps, etc.). You can perform parameter settings from the operation panel. See *Chapter 3 Using the Operator Panel, section 3.5.2 Changing Serial Interface Parameters on page 3-35*.

- 6 On the computer, set the same parameters as that of the printer. Most computers allow you to do this by DIP switch settings that should be made before power is turned on.

With Windows XP, make settings as follows:

- 1 Click on the **Start** button in the Windows XP task bar and align the cursor with **Settings**, then click on **Control Panel** from among the items displayed.
- 2 The **Control Panel** window opens. Double click on **System**.
- 3 **System Properties** window opens. Click on the **Hardware** tab, then click on the **Device Manager** button, and double click on **Ports (COM & LPT)**.

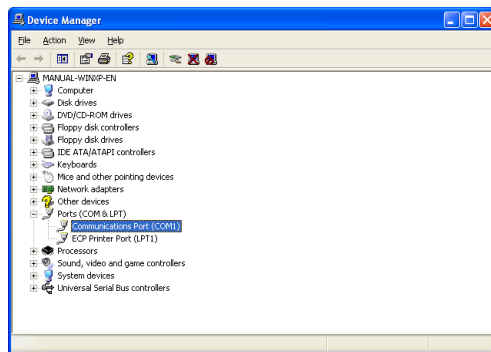

Figure B-1

- 4 Double click on **Communications Port**.
- 5 The **Communications Port Properties** dialog is displayed for the selected COM port. Click on the **Port Settings** tab and set the port properties.

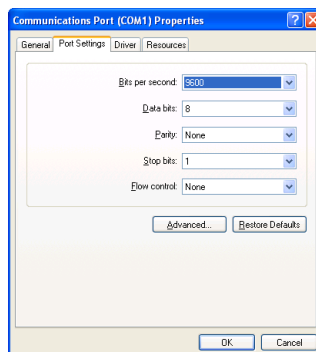

Figure B-2

- 6 After setting the properties, click the **OK** button.

With Windows 95/98/Me, make settings as follows:

- 1** Click on the **Start** button in the Windows 95/98/Me task bar and align the cursor with **Settings**, then click on **Control Panel** from among the items displayed.
- 2** The **Control Panel** window opens. Double click on **System**.
- 3** **System Properties** window opens. Click on the **Device Manager** tab, then double click on **Ports (COM & LPT)**.

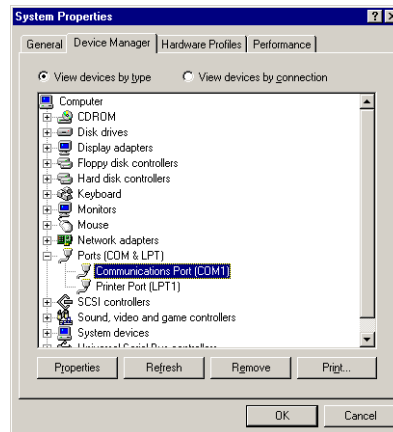

Figure B-3

- 4** Double click on **Communications Port**.
- 5** The **Communications Port Properties** dialog is displayed for the selected COM port. Click on the **Port Settings** tab and set the port properties.

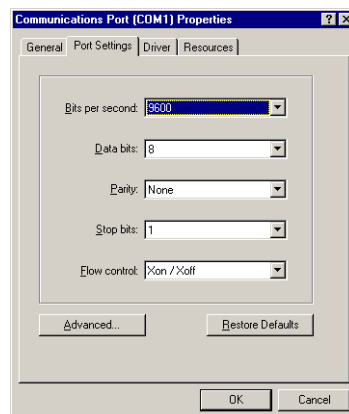

Figure B-4

- 6** After setting the properties, click the **OK** button.

In DOS, enter the following commands:

```
C:\>MODE COM1:96,N,8,1,P  
C:\>MODE LPT1:=COM1
```

To test the interface, enter the following:

```
CTRL P  
C:\>DIR  
CTRL P
```

The software settings made using the above procedures are temporary. On most computers, permanent settings must be made with DIP switches.

Appendix C Technical Specifications

The technical specification may be changed for improvement purpose.

C.1 Printer Specification

Item		Specification
Printing method		Electrographic by Advanced Beam Array, tandem intermediate transfer belt
Printing speed		See section C.2 Printing Speeds on page C-4 .
Resolution		600 dpi (horizontal and vertical)
First print (A4, 23 °C)		Approximately 16 seconds or less (from power on) Approximately 96 seconds or less (from sleep mode)
Warm up time (23 °C)		80 seconds or less
Main Controller CPU		PowerPC 750CXe (400 MHz)
Main memory		96 MB, expandable up to 608 MB maximum
Expansion Memory Module		32, 64, 128, or 256 MB (for 2 slots)
Operating system		Windows 95/98/Me, Windows NT/2000/XP
Interfaces	Parallel	IEEE1284
	USB	USB 2.0 Full-Speed
	Network	Protocol support: TCP/IP, IPX/SPX, NetBEUI, EtherTalk
	Option	Network interface card or Serial interface board (KUIO-LV)/Hard disk
Memory card slot		Compact flash memory card, maximum 256 MB
Self-diagnostics		Performed at power-on
Maximum duty cycle (for standard dry A4 plain paper)		85,000 pages per month
Imaging drum		OPC
Developers		Touchdown projection development
Main charger		Positive scorotron charger
Transferring	Primary	Belt system
	Secondary	Roller system
Separation		Small diameter separation
Drum cleaning		Blade cleaner
Primary transfer belt cleaning		Brush cleaner
Drum discharging		Discharging LED
Fuser		Heat rollers
Paper		See Chapter 2 Handling Paper; section 2.1.2 Paper specifications on page 2-2 .
Paper sizes	Cassettes	A4, B5, A5, legal, and letter sizes, adjustable
	Multi-purpose tray	70 × 216 mm to 148 × 297 mm
Unprintable areas		A top, bottom, left, or right margin of 4 mm
Paper capacity	Cassettes	500 sheets (80 g/m ²)
	Multi-purpose tray	100 sheets (80 g/m ²)
Output tray capacities	Face-down tray	250 sheets (80 g/m ²)
	Face-up tray (option)	250 sheets (80 g/m ²) [100 sheets (80 g/m ²) when the optional duplexer is installed.]

Table C-1

Item	Specification	
Operating environment	Temperature	10 to 32.5 °C (50 to 90.5 °F)
	Relative humidity	15 to 80 %
	Optimum conditions	23 °C (73 °F), 60 % (relative humidity)
	Altitude	2,000 m (6,500 feet) maximum
	Illumination	1,500 lux or less
Power supply	U.S.A. and Canada	120 V, 60 Hz, 9.1 A max
	Europe, Asia, and other countries	220 to 240 V, 50 or 60 Hz, 4.5 A max. at 230 V
	Allowable voltage fluctuations	± 10 % maximum
	Allowable frequency fluctuations	± 2 % maximum
Power consumption	U.S.A. and Canada	Maximum: 1,037 W Normal operation: 491 W Standby: 199 W Sleeping: 21 W
	Europe, Asia, and other countries	Maximum: 991 W Normal operation: 483 W Standby: 202 W Sleeping: 24 W
Noise [†]	Printing	LpA = 53 dB (A)
	Standby	LpA = 36 dB (A)
	Sleeping	Unmeasurably low
Dimensions	345 (13-9/16) wide × 385 (15-3/16) high × 470 mm (18-1/2 inches) deep	
Weight	24 kg (52-7/8 lb)	

Table C-1 (Continued)

[†] In accordance with ISO 7779 (Bystander Position, sound pressure level at the front)

C.2 Printing Speeds

Mode	Paper Size	Print Speeds (color/monochrome)
Simplex printing	A4	16 pages/minute
	Letter, B5, A5	17 pages/minute
	Legal	14 pages/minute
	Thick (A4) [†] , Transparency (A4) [†]	8 pages/minute
Duplex printing ^{††}	A4, Letter, B5, A5	16 pages/minute
	Legal	14 pages/minute

Table C-2

[†] Only with MP tray feeding

^{††} The DU-300 duplex unit is required.

Index

A

- Audible alarm
 - how to set 3-96
- Auto-continue
 - changing recovery time 3-98
 - how to set 3-97

C

- Carriage return
 - how to select 3-56
- Cleaning
 - advanced beam array lens 5-17
 - main charger unit 5-11
 - paper transfer unit 5-16
 - using the grid cleaning tool 5-13
- Color control
 - calibration 3-104
 - registration 3-100
 - selecting monochrome or color printing 3-86
- Counters
 - reading the life counters 3-87
 - reading the total printed pages 3-87
 - toner, how to reset 3-88

D

- Data dump
 - receiving data for damping 3-93
- Duplex printing
 - binding modes 3-78
 - description 3-78
 - note on using the MP tray 3-79
- Duplex unit
 - option, diagrammed A-8

E

- e-MPS
 - as software feature 1-3
 - changing configuration 3-30
 - general information 3-20
 - how to change hard disk spaces 3-30
 - printing a list of code jobs 3-27
- Emulation
 - appearing on the status page 3-19
 - KPDL, printing errors 3-44
 - KPDL, setting the alternative emulation 3-43
 - setting the default using the operator panel 3-42
- Envelope
 - requirements 2-19

Error log

- on the status page 3-19

Error messages

- of hard disk 4-11
- of memory card 4-11
- of RAM disk 4-11
- tabled, with corrective actions 4-7

F

- Face-down tray
 - location and function 1-6
- Face-up output tray
 - option, diagrammed A-9
- Font
 - adjusting character pitch for fixed fonts 3-48
 - changing the default size 3-47
 - printing lists of fonts 3-50
 - sample of the font list 3-51
 - selecting regular or dark Courier/Letter Gothic 3-46
 - setting the default using the operator panel 3-45
- Formfeed
 - changing timeout time 3-90

G

- Gloss mode
 - how to select 3-58

H

- Handling 2-1
- Hard disk
 - as an option A-10
 - deleting data 3-62
 - formatting 3-63
 - writing data 3-61

I

- Indicators
 - Interface 3-3
 - Paper Size 3-4
 - Paper Type 3-5
 - Ready, Data, Attention 3-5

- J**
Job retention
 functions tabled 3-20
 private job, how to use 3-24
 proof-and-hold, how to use 3-23
 quick copy, how to use 3-21
Job storage
 functions 3-21
- K**
Keys
 arrow keys 3-7
 basic operation 3-6
 Cancel 3-6
 Enter 3-7
 Go 3-6
 Menu 3-7
KPD3
 as software feature 1-4
- L**
Label
 required composition 2-17
 requirements 2-18
Linefeed
 how to select 3-55
- M**
Main charger unit
 location 1-6
Memory
 expanding memory A-3
 installing memory modules A-4
 on the status page 3-19
Memory card
 deleting data 3-62
 formatting 3-63
 inserting in the slot A-7
 location of the slot 1-8
 writing data 3-61
Menu map
 how to print 3-15
 sample 3-16
Menu selection system
 road map 3-8
Message display
 changing the language 3-89
 for replacing toner containers 5-3
 indicators included 3-3
 Online help messages 4-13
 status information 3-2
- MP tray
 clearing paper jam 4-17
 first mode, cassette mode 3-68
 location and function 1-5
 setting the paper size 3-69
 setting the paper type 3-71
- N**
Network interface
 a sample of the network status page 3-41
 interface cards, diagrammed A-11
 location of the slot 1-8
 printing a network status page 3-40
 protocols and parameters 3-37
 resolving the IP address 3-39
Number of copies
 how to select 3-52
- O**
Online help messages
 for clearing paper jams 4-13
Operator panel
 configuring the printer defaults 3-42
 diagram 3-2
 function 1-5, 3-2
Options
 a list of, diagrammed A-2
Orientation
 how to select 3-53
Output device
 how to select 3-85
Override A4/Letter
 description 3-80
- P**
Page protect mode
 how to select 3-54

- Paper
 - available paper 2-2
 - basic requirements 2-5
 - colored 2-20
 - envelopes 2-19
 - guidelines for choice 2-4
 - label 2-17
 - minimum and maximum sizes 2-3
 - other properties 2-7
 - paper sizes tabled, as Paper Size indicator 3-4
 - paper types, as Paper Type indicator 3-5
 - pre-printed 2-20
 - recommended makes and types 2-3
 - recycled 2-20
 - special paper 2-16
 - specifications, tabled 2-2
 - standard sizes 2-4
 - thick paper 2-19
 - transparencies 2-17
- Paper cassette
 - as hardware feature 1-3
 - clearing paper jam 4-14
 - diagram 1-5
 - selecting the paper feed source 3-77
 - setting paper size 3-72
 - setting paper type 3-76
- Paper feeder
 - diagrammed A-8
- Paper jam
 - general considerations 4-13
 - messages and corrective actions, diagrammed 4-14
 - possible locations, diagrammed 4-12
- Paper transfer unit
 - location and function 1-7
- Paper type
 - creating custom 3-80
 - how to create custom paper types 3-81
 - resetting the custom paper type 3-84
- Parallel interface
 - changing parallel interface mode 3-34
 - connector, location 1-8
 - signals and definitions B-3
 - understanding the modes B-2
- Partition
 - a sample of the partition list 3-65
 - printing a list of 3-64
- PRESCRIBE
 - as software feature 1-3
- Print quality
 - Gloss mode 3-58
- Printing problems
 - general guidelines tabled 4-2
 - print quality problems, blank printing, etc. 4-3

- R**
- RAM disk
 - setup 3-59
- Reset
 - resetting the printer 3-94
- Resource protection
 - description 3-95

- S**
- Serial interface
 - cabling B-9
 - changing parameters 3-35
 - computer interface B-10
 - protocol, RS-232C B-7
 - signals and definitions B-6
- Setting the Timer 3-91
- Sleep timer
 - setting the timer 3-91
 - setting timeout time 3-92
- Status page
 - how to print 3-17
 - understanding 3-18
- Storage device
 - reading fonts from 3-59
 - reading/writing 3-60
 - writing data 3-61

- T**
- Toner containers
 - diagram 1-7
 - how to replace 5-4
 - kits 5-2
 - replacement 5-2
 - replacement, messages 5-3
 - service life 5-2
 - starter containers 5-2
- Transparency
 - recommended makes and types 2-17
- Two-dimensional barcode
 - as software feature 1-4

- V**
- Virtual mailbox
 - functions 3-21
 - how to change the maximum space 3-33
 - printing a list of mailboxes 3-28
 - retrieving jobs from 3-28

W

Waste toner box

location 1-6

location and replacement 5-8

Kyocera Mita Corporation

2-28, 1-Chome, Tamatsukuri
Chuo-ku, Osaka, 540-8585 Japan

Free Manuals Download Website

<http://myh66.com>

<http://usermanuals.us>

<http://www.somanuals.com>

<http://www.4manuals.cc>

<http://www.manual-lib.com>

<http://www.404manual.com>

<http://www.luxmanual.com>

<http://aubethermostatmanual.com>

Golf course search by state

<http://golfingnear.com>

Email search by domain

<http://emailbydomain.com>

Auto manuals search

<http://auto.somanuals.com>

TV manuals search

<http://tv.somanuals.com>