



FS-C8026N

Color Page Printer



Operation Guide

Safety Notes

Please read the Operation Guide before using the printer. Keep it close to the printer for easy reference.

The sections of this guide and parts of the printer marked with symbols are safety warnings meant to protect the user, other individuals and surrounding objects, and ensure correct and safe usage of the printer. The symbols and their meanings are indicated below.

⚠ WARNING: Indicates that serious injury or even death may result from insufficient attention to or incorrect compliance with the related points.

⚠ CAUTION: Indicates that personal injury or mechanical damage may result from insufficient attention to or incorrect compliance with the related points.

Symbols

The \triangle symbol indicates that the related section includes safety warnings. Specific points of attention are indicated inside the symbol.

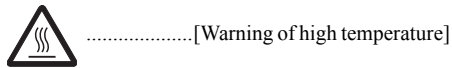
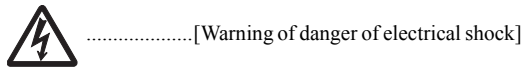
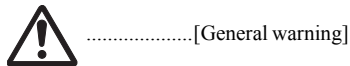

The \otimes symbol indicates that the related section includes information on prohibited actions. Specifics of the prohibited action are indicated inside the symbol.

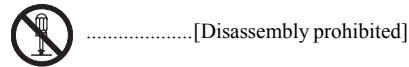
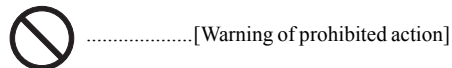

The \bullet symbol indicates that the related section includes information on actions which must be performed. Specifics of the required action are indicated inside the symbol.

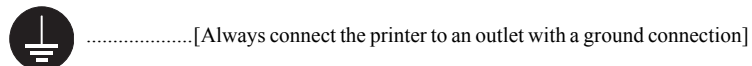
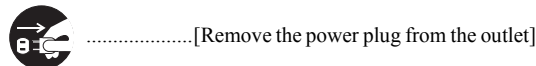
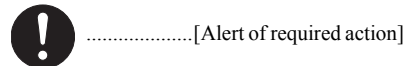

Please contact your service representative to order a replacement if the safety warnings in the guide are illegible or if the guide itself is missing. (fee required)

Caution

NO LIABILITY IS ASSUMED FOR ANY DAMAGE CAUSED BY IMPROPER INSTALLATION.

Notice on Software

SOFTWARE USED WITH THIS PRINTER MUST SUPPORT THE PRINTER'S EMULATION MODE. The printer is factory-set to emulate the PCL. The emulation mode can be changed by following the procedures described in [Chapter 3](#).

Notice

The information in this guide is subject to change without notification. Additional pages may be inserted in future editions. The user is asked to excuse any technical inaccuracies or typographical errors in the present edition.

No responsibility is assumed if accidents occur while the user is following the instructions in this guide. No responsibility is assumed for defects in the printer's firmware (contents of its read-only memory).

This guide, any copyrightable subject matter sold or provided with or in connection with the sale of the page printer, are protected by copyright. All rights are reserved. Copying or other reproduction of all or part of this guide, any copyrightable subject matter without the prior written consent of Kyocera Mita Corporation is prohibited. Any copies made of all or part of this guide, any copyrightable subject must contain the same copyright notice as the material from which the copying is done.

Regarding Tradenames

PRESCRIBE is a registered trademark of Kyocera Corporation. KPDL is trademark of Kyocera Corporation.

Diablo 630 is a product of Xerox Corporation. IBM Proprinter X24E is a product of International Business Machines Corporation. Epson LQ-850 is a product of Seiko Epson Corporation.

Hewlett-Packard, PCL, and PJI are registered trademarks of Hewlett-Packard Company. Centronics is a trade name of Centronics Data Computer Inc. PostScript is a registered trademark of Adobe Systems Incorporated. Macintosh is a registered trademark of Apple Computer, Inc. Microsoft, Windows, and Windows NT are registered trademarks of Microsoft Corporation. PowerPC and Microdrive are trademarks of International Business Machines Corporation. CompactFlash is a trademark of SanDisk Corporation. ENERGY STAR is a U.S. registered mark. All other brand and product names are registered trademarks or trademarks of their respective companies.

This Kyocera Mita page printer uses PeerlessPrintXL to provide the HP LaserJet compatible PCL 6 language emulation. PeerlessPrintXL is a trademark of The Peerless Group, Redondo Beach, CA 90278, U.S.A.

This product was developed using the Tornado™ Real Time Operating System and Tools from Wind River Systems.

AGFA  This product contains UFST™ and MicroType® from Agfa Monotype Corporation.

IBM PROGRAM LICENSE AGREEMENT

THE DEVICE YOU HAVE PURCHASED CONTAINS ONE OR MORE SOFTWARE PROGRAMS (PROGRAMS) WHICH BELONG TO INTERNATIONAL BUSINESS MACHINES CORPORATION (IBM). THIS DOCUMENT DEFINES THE TERMS AND CONDITIONS UNDER WHICH THE SOFTWARE IS BEING LICENSED TO YOU BY IBM. IF YOU Do not AGREE WITH THE TERMS AND CONDITIONS OF THIS LICENSE, THEN WITHIN 14 DAYS AFTER YOUR ACQUISITION OF THE DEVICE YOU MAY RETURN THE DEVICE FOR A FULL REFUND. IF YOU Do not SO RETURN THE DEVICE WITHIN THE 14 DAYS, THEN YOU WILL BE ASSUMED TO HAVE AGREED TO THESE TERMS AND CONDITIONS.

The Programs are licensed not sold. IBM, or the applicable IBM country organization, grants you a license for the Programs only in the country where you acquired the Programs. You obtain no rights other than those granted you under this license.

The term Programs means the original and all whole or partial copies of it, including modified copies or portions merged into other programs. IBM retains title to the Programs. IBM owns, or has licensed from the owner, copyrights in the Programs.

1. License

Under this license, you may use the Programs only with the device on which they are installed and transfer possession of the Programs and the device to another party.

If you transfer the Programs, you must transfer a copy of this license and any other documentation to the other party. Your license is then terminated. The other party agrees to these terms and conditions by its first use of the Program.

You may not:

- 1) use, copy, modify, merge, or transfer copies of the Program except as provided in this license;
- 2) reverse assemble or reverse compile the Program; or
- 3) sublicense, rent, lease, or assign the Program.

2. Limited Warranty

The Programs are provided AS IS.

THERE ARE NO OTHER WARRANTIES COVERING THE PROGRAMS (OR CONDITIONS), EXPRESS OR IMPLIED, INCLUDING, BUT NOT LIMITED TO, THE IMPLIED WARRANTIES OF MERCHANTABILITY AND FITNESS FOR A PARTICULAR PURPOSE.

Some jurisdictions do not allow the exclusion of implied warranties, so the above exclusion may not apply to you.

3. Limitation of Remedies

IBM's entire liability under this license is the following:

- 1) For any claim (including fundamental breach), in any form, related in any way to this license, IBM's liability will be for actual damages only and will be limited to the greater of:
 - a) the equivalent of U.S. \$25,000 in your local currency; or
 - b) IBM's then generally available license fee for the Program

This limitation will not apply to claims for bodily injury or damages to real or tangible personal property for which IBM is legally liable.

IBM will not be liable for any lost profits, lost savings, or any incidental damages or other economic consequential damages, even if IBM, or its authorized supplier, has been advised of the possibility of such damages. IBM will not be liable for any damages claimed by you based on any third party claim. This limitation of remedies also applies to any developer of Programs supplied to IBM. IBM's and the developer's limitations of remedies are not cumulative. Such developer is an intended beneficiary of this Section. Some jurisdictions do not allow these limitations or exclusions, so they may not apply to you.

4. General

You may terminate your license at any time. IBM may terminate your license if you fail to comply with the terms and conditions of this license. In either event, you must destroy all your copies of the Program. You are responsible for payment of any taxes, including personal property taxes, resulting from this license. Neither party may bring an action, regardless of form, more than two years after the cause of action arose. If you acquired the Program in the United States, this license is governed by the laws of the State of New York. If you acquired the Program in Canada, this license is governed by the laws of the Province of Ontario. Otherwise, this license is governed by the laws of the country in which you acquired the Program.

Typeface Trademark Acknowledgement

All resident fonts in this printer are licensed from Agfa Corporation.

Helvetica, Palatino and Times are registered trademarks of Linotype-Hell AG. ITC Avant Garde Gothic, ITC Bookman, ITC ZapfChancery and ITC Zapf Dingbats are registered trademarks of International Typeface Corporation.

Agfa Monotype License Agreement

- 1) Software shall mean the digitally encoded, machine readable, scalable outline data as encoded in a special format as well as the UFST Software.
- 2) You agree to accept a non-exclusive license to use the Software to reproduce and display weights, styles and versions of letters, numerals, characters and symbols (Typefaces) solely for your own customary business or personal purposes at the address stated on the registration card you return to Agfa Japan. Under the terms of this License Agreement, you have the right to use the Fonts on up to three printers. If you need to have access to the fonts on more than three printers, you need to acquire a multi-user license agreement which can be obtained from Agfa Japan. Agfa Japan retains all rights, title and interest to the Software and Typefaces and no rights are granted to you other than a License to use the Software on the terms expressly set forth in this Agreement.
- 3) To protect proprietary rights of Agfa Japan, you agree to maintain the Software and other proprietary information concerning the Typefaces in strict confidence and to establish reasonable procedures regulating access to and use of the Software and Typefaces.
- 4) You agree not to duplicate or copy the Software or Typefaces, except that you may make one backup copy. You agree that any such copy shall contain the same proprietary notices as those appearing on the original.
- 5) This License shall continue until the last use of the Software and Typefaces, unless sooner terminated. This License may be terminated by Agfa Japan if you fail to comply with the terms of this License and such failure is not remedied within thirty (30) days after notice from Agfa Japan. When this License expires or is terminated, you shall either return to Agfa Japan or destroy all copies of the Software and Typefaces and documentation as requested.
- 6) You agree that you will not modify, alter, disassemble, decrypt, reverse engineer or decompile the Software.
- 7) Agfa Japan warrants that for ninety (90) days after delivery, the Software will perform in accordance with Agfa Japan-published specifications, and the diskette will be free from defects in material and workmanship. Agfa Japan does not warrant that the Software is free from all bugs, errors and omissions.

THE PARTIES AGREE THAT ALL OTHER WARRANTIES, EXPRESSED OR IMPLIED, INCLUDING WARRANTIES OF FITNESS FOR A PARTICULAR PURPOSE AND MERCHANTABILITY, ARE EXCLUDED.
- 8) Your exclusive remedy and the sole liability of Agfa Japan in connection with the Software and Typefaces is repair or replacement of defective parts, upon their return to Agfa Japan.

IN NO EVENT WILL AGFA JAPAN BE LIABLE FOR LOST PROFITS, LOST DATA, OR ANY OTHER INCIDENTAL OR CONSEQUENTIAL DAMAGES, OR ANY DAMAGES CAUSED BY ABUSE OR MISAPPLICATION OF THE SOFTWARE AND TYPEFACES.
- 9) New York, U.S.A. law governs this Agreement.
- 10) You shall not sublicense, sell, lease, or otherwise transfer the Software and/or Typefaces without the prior written consent of Agfa Japan.
- 11) Use, duplication or disclosure by the Government is subject to restrictions as set forth in the Rights in Technical Data and Computer Software clause at FAR 252-227-7013, subdivision (b)(3)(ii) or subparagraph (c)(1)(ii), as appropriate. Further use, duplication or disclosure is subject to restrictions applicable to restricted rights software as set forth in FAR 52.227-19 (c)(2).
- 12) YOU ACKNOWLEDGE THAT YOU HAVE READ THIS AGREEMENT, UNDERSTAND IT, AND AGREE TO BE BOUND BY ITS TERMS AND CONDITIONS. NEITHER PARTY SHALL BE BOUND BY ANY STATEMENT OR REPRESENTATION NOT CONTAINED IN THIS AGREEMENT. NO CHANGE IN THIS AGREEMENT IS EFFECTIVE UNLESS WRITTEN AND SIGNED BY PROPERLY AUTHORIZED REPRESENTATIVES OF EACH PARTY. BY OPENING THIS DISKETTE PACKAGE, YOU AGREE TO ACCEPT THE TERMS AND CONDITIONS OF THIS AGREEMENT.

FCC STATEMENT (for USERS in the United States)

This device complies with Part 15 of the FCC Rules. Operation is subject to the following two conditions: (1) This device may not cause harmful interference, and (2) this device must accept any interference received, including interference that may cause undesired operation.

Note

This equipment has been tested and found to comply with the limits for a Class B digital device, pursuant to Part 15 of the FCC Rules. These limits are designed to provide reasonable protection against harmful interference in a residential installation. This equipment generates, uses, and can radiate radio frequency energy and, if not installed and used in accordance with the instructions, may cause harmful interference to radio communications. However, there is not guarantee that interference will not occur in a particular installation. If this equipment does not cause harmful interference to radio or television reception, which can be determined by turning the equipment off and on, the user is encouraged to try to correct the interference by one or more of the following measures:

- Reorient or relocate the receiving antenna.
- Increase the distance between the equipment and the receiver.
- Connect the equipment into an outlet on a circuit different from that used for the receiver.
- Consult the dealer or an experienced radio/TV technician for help.

Changes or modifications not expressly approved by the manufacturer for compliance could void the user's authority to operate the equipment. Shielded circular cables should be used for interfacing with the computer.

Cautions to the user

- Any modifications without prior permission of Kyocera may cause harmful interference.
- If any modifications or changes are made to this equipment without prior permission of Kyocera, Kyocera as the manufacturer does not guarantee the compliance with the FCC Rules.
- The use of equipment that does not comply with the FCC Rules is prohibited.





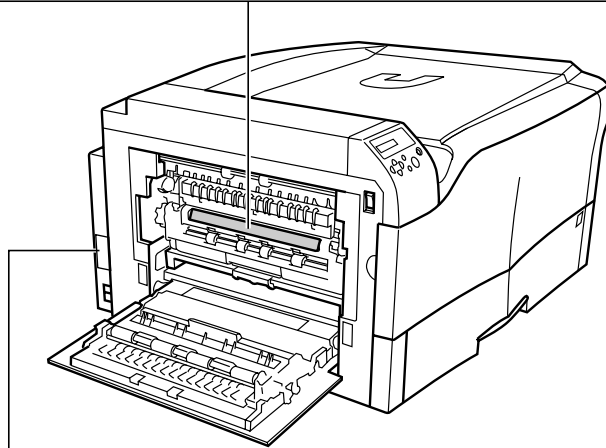

Cautionary Labels

The printer bears any of the following labels.



For Europe, Asia,
and other countries

FS-C8026N 220-240V~
50/60Hz 6.5A
KYOCERA MITA CORPORATION

ACN003852444

CAUTION
REMOVE POWER CORD BEFORE SERVICE
AND FUSE REPLACEMENT.

VORSICHT
VOR WARTUNG UND SICHERUNGS-
WECHSEL NETZSTECKER ZIEHEN.

ATTENTION
POUR PRÉVENIR LES CHOCS
ÉLECTRIQUES, COUPER L'ALIMENTATION
AVANT DE REMPLACER LE FUSIBLE.





ATENCIÓN
DESENCHUFE EL CORDÓN
DE ALIMENTACIÓN ANTES DEL SERVICIO Y
DEL REEMPLAZO DEL FUSIBLE.

PRECAUZIONE
PRIMA DI CAMBIARE I FIESIBILI O
DI ESEGUIRE RIPARAZIONI,
STACCATTE IL CADO DI ALIMENTAZIONE.

MADE IN JAPAN >ABS<

For U.S.A. and Canada

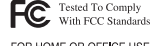
FS-C8026N 120V~
60Hz 12.0A
KYOCERA MITA CORPORATION
TAMAKI PLANT
704-19 NOJINO, TAMAKI-TOWN
WATARAI-COUNTY, MIE-PREF, JAPAN
MANUFACTURED: U2

8J68
Tested To Comply
With FCC Standards

FOR HOME OR OFFICE USE
This device complies with Part 15 of
the FCC Rules.
Operation is subject to the following two
conditions: (1) This device may not cause
harmful interference, and (2) this device
must accept any interference received,
including interference that may cause
undesired operation.
This Class B digital apparatus complies
with Canadian ICES-003.
Cet appareil numérique de la classe B est
conforme à la norme NMB-003 du Canada.

CAUTION
REMOVE POWER CORD BEFORE SERVICE
AND FUSE REPLACEMENT.

ATTENTION
POUR PRÉVENIR LES CHOCS
ÉLECTRIQUES, COUPER L'ALIMENTATION
AVANT DE REMPLACER LE FUSIBLE.

PRECAUZIONE
PRIMA DI CAMBIARE I FIESIBILI O
DI ESEGUIRE RIPARAZIONI,
STACCATTE IL CADO DI ALIMENTAZIONE.

YM MADE IN JAPAN >PS<

Ozone concentration

The printers generate ozone gas (O₃) which may concentrate in the place of installation and cause an unpleasant smell. To minimize the concentration of ozone gas to less than 0.1 ppm, we recommend you not to install the printer in a confined area where ventilation is blocked.

Declaration of Conformity for U.S.A.

Model name: Color Page Printer FS-C8026N
Trade name: Kyocera Mita
Responsible party: Kyocera Mita America, Inc.
Address: 225 Sand Road PO Box 40008 Fairfield, New Jersey 07004-0008, U.S.A.
Telephone: (973) 808-8444
Fax: (973) 882-6000

Manufacturer: Kyocera Mita Corporation Tamaki Plant
Manufacturer's address: 704-19, Nojino, Tamaki-cho, Watarai-gun, Mie-ken 519-0497, Japan

This device complies with Part 15 of the FCC Rules. Operation is subject to the following two conditions: (1) this device may not cause harmful interference, and (2) this device must accept any interference received, including interference that may cause undesired operation.

The manufacturer and its merchandising companies retain the following technical documentation in anticipation of the inspection that may be conducted by the authorities concerned.

User's instruction that conforms to the applicable specifications.

Technical drawings.

Descriptions of the procedures that guarantee the conformity.

Other technical information.

Kyocera Mita America Inc.

CE Marking Directive

According to Council Directive 89/336/EEC and 73/23/EEC

Manufacturer: Kyocera Mita Corporation Tamaki Plant
Manufacturer's address: 704-19, Nojino, Tamaki-cho, Watarai-gun, Mie-ken 519-0497, Japan

Declares that the product

Product name: Color Page Printer

Model number: FS-C8026N

(as tested with enhancement optional units; paper feeder PF-640/645, document finisher DF-610, H.D.D HD-10, IB-21E etc.)

Conforms to the following product specifications:

EN 55 022: 1998 Class B

EN 61 000-3-2: 1995

EN 61 000-3-3: 1995

EN 55 024: 1998

EN 60 950: 2000

The manufacturer and its merchandising companies retain the following technical documentation in anticipation of the inspection that may be conducted by the authorities concerned.

User's instruction that conforms to the applicable specifications.

Technical drawings.

Descriptions of procedures that guarantee conformity.

Other technical information.

Declaration of Conformity for Australia

Manufacturer: Kyocera Mita Corporation Tamaki Plant
Manufacturer's address: 704-19, Nojino, Tamaki-cho, Watarai-gun, Mie-ken 519-0497, Japan
declares that the product

Product name: Color Page Printer
Model name: FS-C8026N

Description of devices: This Page Printer Model FS-C8026N is the 26 ppm, A4 size and utilized plane paper; dry toner; etc. The printer can be equipped with several enhancement optional units as a paper feeder PF-640/645, document finisher DF-610, H.D.D HD-10, IB-21E, etc.

conforms to the following product specifications:

AS/NZS 3548: 1995 (EN 55022: 1998 Class B)
IEC60950: 1999 (EN 60950: 2000)

The manufacturer and its merchandising companies retain the following technical documentation in anticipation of the inspection that may be conducted by the authorities concerned.

User's instruction that conforms to the applicable specifications
Technical drawings
Descriptions of procedures that guarantee conformity
Other technical information

Kyocera Mita Australia Pty., Ltd.
6-10 Talavera Road, North Ryde, NSW 2113, Australia
Telephone: +61 2-9888-9999
Fax: +61 2-9888-9588

Canadian Department of Communications compliance statement

This Class B digital apparatus complies with Canadian ICES-003.

Avis de conformité aux normes du ministère des Communications du Canada

Cet appareil numérique de la classe B est conforme à la norme NMB-003 du Canada.

ISO 7779

Maschinenlärminformationsverordnung 3. GSGV, 18.01.1991: Der höchste Schalldruckpegel beträgt 70 dB (A) oder weniger gemäß ISO 7779.

Disclaimer

Kyocera Mita will not be liable to customers or any other person or entity for any loss or damage caused or alleged to be caused directly or indirectly by equipment sold or furnished by us, including but not limited to, any interruption of service, loss of business or anticipatory profits, or consequential damages resulting from the use or operation of the equipment or software.

ENERGY STAR®



As an ENERGY STAR Partner, we have determined that this product meets the ENERGY STAR guidelines for energy efficiency.

The basic objective of the ENERGY STAR Program is to reduce environmental pollution by encouraging the manufacture and sale of equipment that uses energy more efficiently.

This printer is equipped with a sleep timer function that conforms with the standards of the ENERGY STAR Program. This function makes it possible to reduce the amount of electrical power consumed by the printer. For maximum power savings, turn off the printer's power supply when not using the printer for extended periods of time.

For details on the sleep timer function and printer power consumption, refer to this manual.

Initial settings of the sleep timer function and power saved using the sleep timer function:

Initial sleep mode setting	Power consumption in sleep mode
30 minutes (60 minutes)	30 W (70 W)

(): ENERGY STAR program guideline

Group for Energy Efficient Appliances (GEEA)



The goal of GEEA is efficient use of energy. This product has a high-efficiency profile and meets the criteria for receiving the GEEA-Label.





Initial sleep mode setting	Power Consumption	
	Power off	Sleep mode
30 min. (30 min.)	0 W (1 W)	30 W (30 W)

(): GEEA criteria

Installation Precautions

Environment

CAUTION

- Avoid placing the printer on or in locations which are unstable or not level. Such locations may cause the printer to fall down or fall over. This type of situation presents a danger of personal injury or damage to the printer. 
- Avoid locations with humidity or dust and dirt. If dust or dirt becomes attached to the power plug, clean the plug to avoid the danger of fire or electrical shock. 
- Avoid locations near radiators, heaters, or other heat sources, or locations near flammable items, to avoid the danger of fire. 
- To keep the printer cool, be sure to allow sufficient space around it as shown below. In particular, be sure to allow sufficient space between the vents on the sides of the printer and walls, etc. Not allowing enough space can impede cooling, which leads to overheating and poor printer performance. 

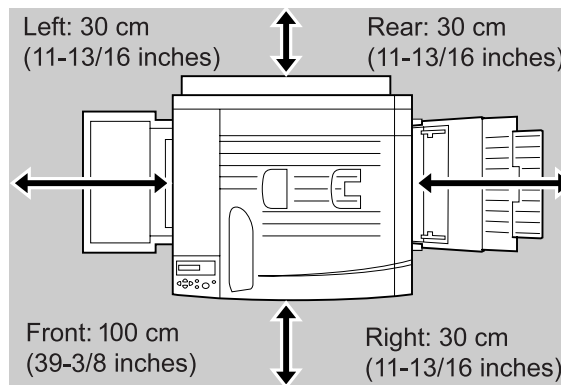



- Always use the caster stoppers to stabilize the printer once it is in place to keep it from moving and/or falling over and causing injury. 

Other Precautions

- Adverse environmental conditions may affect the safe operation and performance of the printer. Install in an air-conditioned room (recommended room temperature: around 20 °C, humidity: around 65 % RH) and avoid the following locations when selecting a site for the printer.
 - Avoid locations near a window or with exposure to direct sunlight.
 - Avoid locations with vibrations.
 - Avoid locations with drastic temperature fluctuations.
 - Avoid locations with direct exposure to hot or cold air.
 - Avoid poorly ventilated locations.
- When casters are installed on the printer, moving the printer can cause damage to certain floor surfaces.

Power Supply/Grounding the Printer

WARNING

- Do not use a power supply with a voltage other than that specified. Avoid multiple connections in the same outlet. These types of situations present a danger of fire or electrical shock. 
- Plug the power cord securely into the outlet. If metallic objects come in contact with the prongs on the plug, it may cause a fire or electric shock. 
- Always connect the printer to an outlet with a ground connection to avoid the danger of fire or electrical shock in case of an electric short. If an earth connection is not possible, contact your service representative. 

Other Precautions

- Connect the power plug to the closest outlet possible to the printer.

Handling of Plastic Bags







WARNING

- Keep the plastic bags that are used with the printer away from children. The plastic may cling to their nose and mouth causing suffocation. 







Precautions for Use

Cautions when Using the Printer

WARNING

- Do not place metallic objects or containers with water (flower vases, flower pots, cups, etc.) on or near the printer. This type of situation presents a danger of fire or electrical shock should they fall inside. 
- Do not remove any of the covers from the printer as there is a danger of electrical shock from high voltage parts inside the printer. 
- Do not damage, break or attempt to repair the power cord. Do not place heavy objects on the cord, pull it, bend it unnecessarily or cause any other type of damage. These types of situations present a danger of fire or electrical shock. 
- If the printer becomes excessively hot, smoke appears from the printer, there is an odd smell, or any other abnormal situation occurs, there is a danger of fire or electrical shock. Turn the power switch OFF (O) immediately, remove the power plug from the outlet and contact your service representative. 
- If anything harmful (paper clips, water, other fluids, etc.) falls into the printer, turn the power switch OFF (O) immediately. Next, remove the power plug from the outlet to avoid the danger of fire or electrical shock. Then contact your service representative. 
- Do not remove or connect the power plug with wet hands, as there is a danger of electrical shock. 
- Always contact your service representative for maintenance or repair of internal parts. 

CAUTION

- Do not pull the power cord when removing it from the outlet. If the power cord is pulled, the wires may become broken and there is a danger of fire or electrical shock. (Always grasp the power plug when removing the power cord from the outlet.) 
- Always remove the power plug from the outlet when moving the printer. If the power cord is damaged, there is a danger of fire or electrical shock. 
- If the printer will not be used for a short period of time (overnight, etc.), turn the power switch OFF (O). If it will not be used for an extended period of time (vacations, etc.), remove the power plug from the outlet for safety purposes during the time the printer is not in use. 
- For safety purposes. Always remove the power plug from the outlet when performing cleaning operations. 
- If dust accumulates within the printer, there is a danger of fire or other trouble. It is therefore recommended that you consult with your service representative in regard to cleaning of internal parts. This is particularly effective if accomplished prior to seasons of high humidity. Consult with your service representative in regard to the cost of cleaning the internal parts of the printer. 
- Do not block the cooling air in and out vents and the exhaust duct against walls or with other objects. If the flow of cooling air is blocked, heat will be built up in the printer, and there will be a risk of fire. 

Other Precautions

- Do not place heavy objects on the printer or cause other damage to the printer.
- Do not open the front cover, turn off the main switch, or pull out the power plug during printing.
- During printing, some ozone is released, but the amount does not cause any ill effect to one's health. If, however, the printer is used over a long period of time in a poorly ventilated room or when printing an extremely large number of copies, the smell may become unpleasant. To maintain the appropriate environment for print work, it is suggested that the room be properly ventilated.
- Do not touch electrical parts, such as connectors or printed circuit boards. They could be damaged by static electricity.
- Do not attempt to perform any operations not explained in this handbook.
- Caution: Use of controls or adjustments or performance of procedures other than those specified herein may result in hazardous radiation exposure.
- If the printer will not be used for an extended period of time, remove the paper from the cassette, return it to its original package and reseal it.

Cautions for Toner Handling

⚠ CAUTION

- Do not incinerate toner and toner containers. Dangerous sparks may cause burn.
- Never open the toner container.
- Make sure not to inhale the toner, and not to rub your eyes or touch your mouth with the hands stained with the toner. And make sure not to stick to your skin.
- For the disposal of old toner container, consult your dealer. Or dispose of the toner or toner containers in accordance with Federal, State and Local rules and regulations.
- Keep away the toner container.



For More Information...

Item	Description
Installation Guide (paper manual)	Describes the printer setup procedure.
Quick Reference Guide (paper manual)	Describes common information about the printer such as loading paper, understanding messages, etc.
The following documents are stored in the CD-ROM as PDF documents.	
Operation Guide (this manual)	Guides you through topics concerning the operations and maintenance of the printer.
KX Printer Drivers Operation Guide	Describes how to install and set the printer driver.
PRESCRIBE Commands Technical Reference	PRESCRIBE is the native language of the Kyocera Mita printers. This Technical Reference contains the information about how the printing is performed using the PRESCRIBE commands as well as the font and emulation description. Also included is a list of permanent parameters and their explanation needed when customizing your printer.
PRESCRIBE Commands Command Reference	Gives a detailed explanation of the PRESCRIBE command syntax and parameters.

Guide to the Operation Guide

This Operation Guide has the following chapters:

Chapter 1 Introduction

This chapter explains printer features and the names of parts.

Chapter 2 Handling Paper

This chapter explains the types of paper that can be used with the printer.

Chapter 3 Using the Operator Panel

This chapter explains the message display, indicators and keys on the operator panel, and how to make various settings from the operator panel.

Chapter 4 Troubleshooting

This chapter explains how to handle printer problems that may occur, such as paper jams.

Chapter 5 Maintenance

This chapter explains how to replace the toner container and how to care for your printer.

Appendix A Options

This appendix introduces the available options to be used with the printer.

Appendix B Computer Interface

This appendix explains the pin assignment and specifications for the printer's parallel interface.

Appendix C Technical Specifications

This appendix lists the printer's specifications.

Contents

Contents

Chapter 1 Introduction

1.1	Features	1-2
1.1.1	General	1-2
1.1.2	Hardware	1-2
1.1.3	Software	1-3
1.1.4	Networking	1-4
1.2	Parts and Functions	1-5
1.2.1	Front	1-5
1.2.2	Internal	1-7
1.2.3	Rear	1-8

Chapter 2 Handling Paper

2.1	General	2-2
2.1.1	Available paper types	2-2
2.1.2	Paper specifications	2-2
2.1.3	Minimum and maximum paper sizes	2-3
2.2	Selecting the Right Paper	2-4
2.2.1	Guidelines	2-4
2.2.2	Paper properties	2-5
2.2.3	Other properties of paper	2-6
2.3	Loading Paper	2-7
2.3.1	Loading paper into the cassette	2-7
2.3.2	Loading paper into the MP (Multi-Purpose) tray	2-8
2.4	Special Paper	2-9
2.4.1	Selecting the special paper	2-9

Chapter 3 Using the Operator Panel

3.1	Understanding the Operator Panel	3-2
3.1.1	Message display	3-2
3.1.2	Indicators in message display	3-3
3.1.3	Keys	3-6
3.2	Using the Menu Selection System	3-8
3.2.1	Menu Selection System	3-8
3.2.2	Menu System Road Map	3-10
3.3	Menu Map and Status Pages	3-15
3.3.1	Printing a Menu Map	3-15
3.3.2	Printing a Status Page	3-17
3.4	e-MPS	3-20
3.4.1	Using Quick Copy	3-21
3.4.2	Using Proof-and-Hold	3-22
3.4.3	Printing a Private Print/Job Retention	3-22
3.4.4	Retrieving Jobs from Virtual Mailbox (VMB)	3-24
3.4.5	Changing e-MPS Configuration	3-25
3.5	Changing the Interface Parameters	3-28
3.5.1	Changing Parallel Interface Mode	3-28
3.5.2	Changing Serial Interface Parameters	3-28
3.5.3	Changing Network Interface Parameters	3-29
3.5.4	Resolving IP Address	3-30
3.6	Making Default Settings	3-32
3.6.1	Default Emulation	3-32

3.6.2	KC-GL Pen Width and Color	3-32
3.6.3	Alternative Emulation for KPDLEmulation	3-33
3.6.4	Printing KPDLErrors	3-33
3.6.5	Default Font	3-34
3.7	Pagination	3-38
3.7.1	Number of Copies	3-38
3.7.2	Print Orientation	3-38
3.7.3	Linefeed (LF) Action	3-39
3.7.4	Carriage-Return (CR) Action	3-39
3.8	Setting Print Quality	3-40
3.8.1	Tone Mode	3-40
3.8.2	Gloss Mode	3-40
3.9	Operating the Storage Device	3-42
3.9.1	Using the Memory Card	3-42
3.9.2	Using the Option Hard Disk (HD-10)	3-46
3.9.3	Using the RAM Disk	3-46
3.10	Paper Handling	3-48
3.10.1	MP Tray Mode	3-48
3.10.2	Setting MP Tray Paper Size	3-48
3.10.3	Setting the MP Tray Paper Type	3-49
3.10.4	Setting the Cassette Paper Type	3-50
3.10.5	Selecting the Paper Feed Source	3-50
3.10.6	Duplex Printing	3-51
3.10.7	Adjusting the Stitch Positions	3-52
3.10.8	Overriding Difference between A4 and Letter	3-53
3.10.9	Creating Custom Paper Types	3-53
3.10.10	Resetting the Custom Paper Type	3-54
3.10.11	Selecting the Output Stack	3-55
3.11	Selecting Monochrome or Color Printing	3-56
3.12	Reading Life Counters	3-57
3.12.1	Displaying the Total Printed Pages	3-57
3.12.2	Resetting the Toner Counter	3-57
3.13	Other Modes	3-58
3.13.1	Selecting the Message Language	3-58
3.13.2	Automatic Form Feed Timeout Setting	3-58
3.13.3	Setting the Sleep Timer	3-59
3.13.4	Received Data Dump	3-60
3.13.5	Printer Resetting	3-60
3.13.6	Resource Protection	3-61
3.13.7	Alarm (Buzzer) Setting	3-61
3.13.8	Auto Continue Setting	3-62
3.13.9	Setting the Auto Continue Recovery Time	3-62
3.13.10	Duplex Printing Error Detection Setting	3-63
3.13.11	Staple Error Detection Setting	3-63
3.13.12	Punch Error Detection Setting	3-64
3.13.13	Mixed Color/Monochrome Print Setting	3-64
3.13.14	Printing the Service Status Page	3-65
3.13.15	Color Calibration	3-65
3.13.16	Using High Density Mode	3-66

Chapter 4 Troubleshooting

4.1	General Guidelines	4-2
4.1.1	Tips	4-2
4.2	Print Quality Problems	4-3
4.3	Error Messages	4-6
4.4	Clearing Paper Jams	4-12
4.4.1	Possible Paper Jam Locations	4-12

4.4.2	General considerations for clearing jams	4-13
4.4.3	Paper Jam – Paper Feed	4-13
4.4.4	Paper Jam — Paper Cassette #	4-14
4.4.5	Paper Jam — MP Tray	4-14
4.4.6	Paper Jam – Duplex Unit	4-15
4.4.7	Paper Jam – Right Cover	4-15
4.4.8	Paper Jam – Paper Feed Unit	4-16
4.4.9	Paper Jam – Left Cover	4-17
4.4.10	Paper Jam – Option Unit	4-17

Chapter 5 Maintenance

5.1	Toner Container Replacement	5-2
5.1.1	Toner Container Replacement Requirements	5-2
5.1.2	Toner Container Replacement Request	5-2
5.1.3	Replacing the Toner Container	5-2
5.2	Replacing the Waste Toner Box	5-5
5.3	Cleaning the Printer	5-7
5.3.1	Cleaning the Registration Roller	5-7
5.3.2	Cleaning the Main Charger Unit	5-7

Appendix A Options

A.1	Options	A-2
A.2	Expansion Memory Modules	A-3
A.3	General Description of Options	A-5

Appendix B Computer Interface

B.1	Parallel Interface	B-2
B.1.1	Communication Modes	B-2
B.1.2	Interface Signals	B-3

Appendix C Technical Specifications

C.1	Printer Specification	C-2
C.2	Printing Speeds	C-4

Index

Chapter 1 Introduction

Welcome to professional color printing from Kyocera Mita. The FS-C8026N Ecosys Color Printer lets you print top quality documents in color or monochrome at 26 pages per minute in A4 paper size, and at 13 pages per minute in B4 and A3 paper sizes.

A full range of options includes a large-capacity paper feeder, duplex unit, document finisher, and more.

1.1 Features

This section outlines the major printer features of the FS-C8026N Ecosys color Page Printer.

1.1.1 General

Components with an ultra-long product life

The main printer components such as the imaging drum, development units, and fuser unit have an ultra-long product life.

The imaging drum has been developed using Kyocera's leading-edge ceramic technology that makes full use of amorphous silicon.

High-speed printing

The printer supports a print speed of 26 pages per minute for both color and monochrome output. Actual printing time depends on the complexity of the page being printed.

Superb color printing quality and versatile color control

This printer allows you to switch the gray level of each pixel between 2 bpp and 4 bpp (bits per pixel). Also, the intelligent color calibration system automatically optimizes colors every time the printer is powered. These media types are also support in various sizes of standard and non-standard.

Variety of paper sizes and types

In addition to ordinary paper, you can use print media such as transparencies, labels, and other special papers for printouts. These media types are also support in various sizes of standard and non-standard.

Sleep mode

The sleep mode conserves energy while printing is in standby.

1.1.2 Hardware

Advanced data processing

A 600 MHz CPU, up to 512 MB of RAM, and the optional hard disk (HD-10) deliver ideal throughput for wide varying printing applications.

Two expansion slots for hardware interfaces

The printer is equipped with two expansion slots for plugging in an optional network interface card and a hard disk (HD-10).

Standard bidirectional parallel interface

The bidirectional parallel interface ensures high-speed data transfer between the host computer and printer.

Memory card slot

You can select and read the data in a memory card inserted in this slot from the printer operator panel.

Paper cassette and tray

The paper cassette can hold approximately 500 sheets of paper. The printer also has a MP (multipurpose) tray that can hold approximately 150 sheets.

Options

Available options include a large-capacity paper feeder, duplex unit, document finisher, and more.

1.1.3 Software

e-MPS

'e-MPS' is an abbreviation for 'enhanced-Multiple Printing System,' which is a post-processing function that combines electronic sorting, job retention, and virtual mailboxing.

When printing multiple copies of a document, the data is transferred from the computer to the printer only for the first copy; the data is then stored on the printer's hard disk. Copies of the document are printed using the stored data.

Printing is performed faster with less computer spooling time and less network traffic.

Furthermore, printed data that is stored on the hard disk can be called up using job retention functions, such as Quick Copy etc., allowing you to quickly print additional copies of a document from the printer at any time, without needing to re-spool the document or start up the computer system.

Printer Control Language PRESCRIBE

The printer uses PRESCRIBE, Kyocera Mita's page printer control language with enhanced color graphics capabilities. The simple commands of PRESCRIBE allow the programmers to easily define pagination and device control.

KPDL3 (Kyocera Printer Description Language 3)

The printer uses KPDL3, Kyocera's implementation of the PostScript page description language Level 3. The printer has 136 fonts that are compatible with Adobe PostScript fonts. The printer also has 80 PCL fonts.

PDF direct print

Allows you to send a selected PDF file directly to the printer without invoking a printer driver.

Account management system

This printer comes equipped with an account management system function which records the number of pages printed by each department. The administrator can preset the maximum number of pages that each department will be allowed to print.

For details on the account management system, refer to the Account Management System Guide.

1.1.4 Networking

Built-in and External Network Interfaces

The network interface supports TCP/IP, IPX/SPX, NetBEUI and EtherTalk protocols. Therefore, network printing is possible with various operating system environments including Windows, Macintosh, UNIX and NetWare.

Support for Network Printer Monitor Utility (KM-NET VIEWER)

Allows network wide management of printers. See the readme file in the CD-ROM (supplied with the printer) for details.

1.2 Parts and Functions

This section provides explanations and illustrations for you to determine the parts and their functions. Try to be familiar with the names and functions of these parts for correct use and optimal performance.

1.2.1 Front

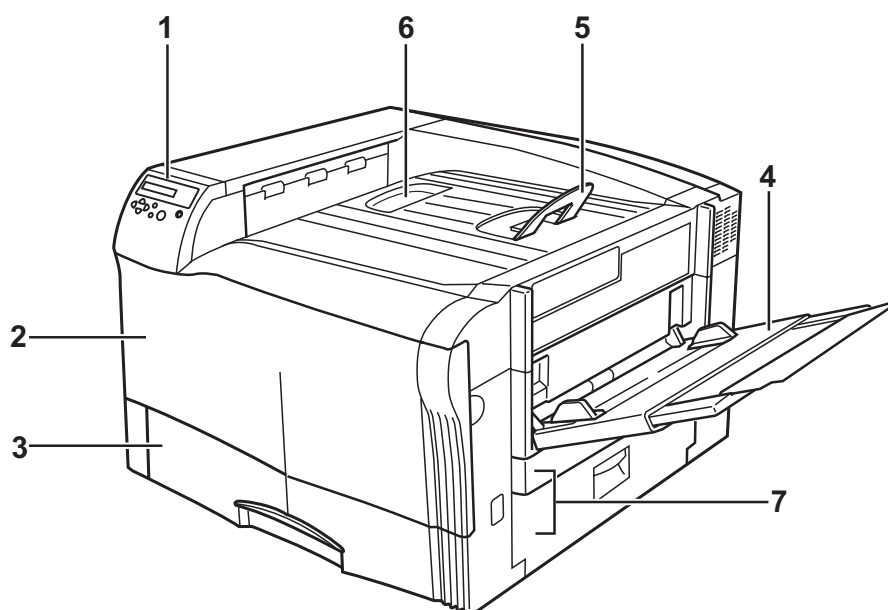

Figure 1-1

- 1 Operator Panel**
Used to specify printer functions and display the printer operating status.
- 2 Front Cover**
When open, this cover gives you access to the interior of the printer when replacing toner containers or the waste toner box. The cover must also be open to clear a paper jam.
- 3 Paper Cassette**
The cassette holds up to 500 sheets of A5 to A3 size paper.
- 4 MP (Multi-Purpose) Tray**
The MP tray holds up to 150 sheets of standard size paper. Transparencies, labels, and other special media must be fed using this tray.
- 5 Paper Stopper**
When standing up, this stopper prevents printed sheets of large size paper from falling off the printer.
- 6 Top (Face-down) Tray**
This tray receives printouts face-down.
- 7 Right Cover**
Open this cover when clearing a paper jam.

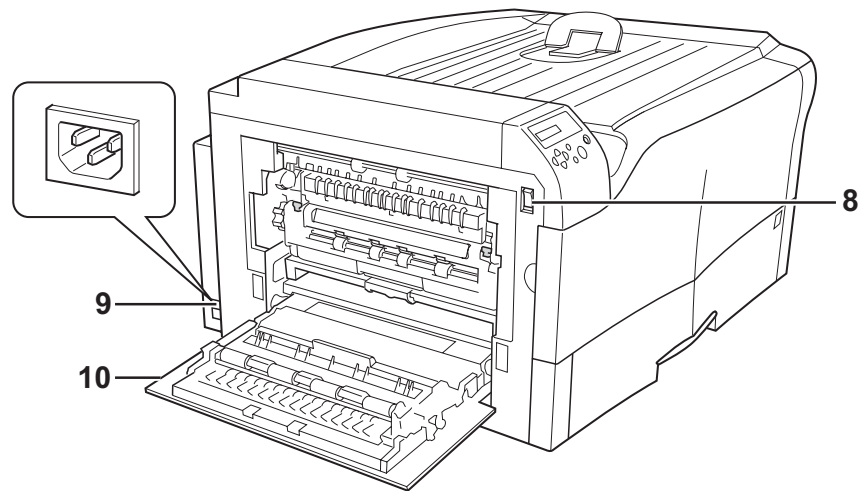

Figure 1-2

- 8 Power Switch**
Turns printer power on and off.
- 9 Power Cord Connector**
Connect the power cord that comes with the printer here.
- 10 Left Cover**
Open this cover when clearing a paper jam.

1.2.2 Internal

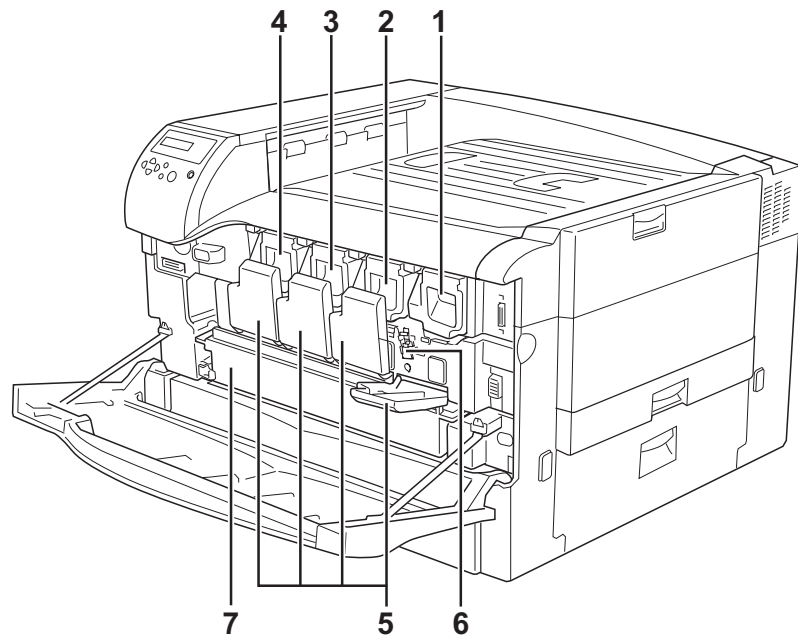

Figure 1-3

- 1 Magenta (M) Toner Container**
- 2 Cyan (C) Toner Container**
- 3 Yellow (Y) Toner Container**
- 4 Black (K) Toner Container**
- 5 Toner Container Cover**
Open this cover when replacing a toner container or when cleaning the charger unit.
- 6 Charger Unit**
This is a high-voltage charger unit that is used for transferring toner to the drum unit. Clean the charger unit whenever you replace a toner container. For details, see [5.3.2 Cleaning the Main Charger Unit on page 5-7](#).
- 7 Waste Toner Box**
Used waste toner collects in this box.

1.2.3 Rear

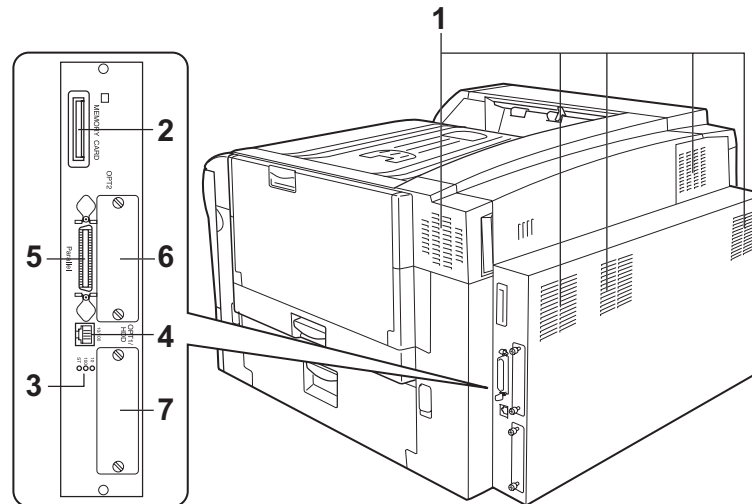

Figure 1-4

1 Vents

Vents allow cooling air to enter and ozone to exit.

2 Memory Card Slot

This slot receives a memory (Compact Flash) card. A memory card can hold fonts, macros, forms, etc., that can be downloaded in the printer's memory. For details, see [Appendix A Options, section A.3.1 Memory Card on page A-5](#).

3 Network Indicators

These indicators light according to the communication status with the network.
 10BASE-T indicator (10): Lights when you are connected to the network at 10 Mbps.
 100BASE-TX indicator (100): Lights when you are connected to network at 100 Mbps.
 Status indicator (ST): Flashes during data communication.

4 Network Interface Connector

Connects to the network via a 10BASE-T/100BASE-TX network cable.

5 Parallel Interface Connector

This connector is for a standard Centronics parallel interface cable from the computer. Connect this connector to the computer's parallel port.

6 Option Interface Card Slot (Network) [OPT2]

This slot holds an optional network interface card for network printing. (An optional Hard disk can't be used in this slot.) For details see [Appendix A Options](#).

7 Hard Disk Slot (OPT1/HDD)

This slot holds an optional hard disk (HD-10) for storing print jobs. A Kyocera Mita manufactured hard disk must be used. For details, see [Appendix A Options, section A.3.7 Hard Disk on page A-7](#).

Chapter 2 Handling Paper

The printer can use a variety of media in various sizes. However, any media you will choose to use with the printer must be in accordance with the guidelines and specifications in this chapter. Use of paper not satisfying these guidelines and specifications may cause problems such as frequent paper jams, poor quality printing, and possible damage to the printer mechanism.

Even complying with the instructions provided in this chapter, special media such as transparencies, labels, envelopes, non-standard-size paper must be fed directly from the printer's MP (multi-purpose) tray and delivered in the face-up tray in 'straight path' manner. For details on use of MP tray, see [Chapter 3 Using the Operator Panel, section 3.10.1 MP Tray Mode on page 3-48](#).

2.1 General

Your Ecosys Color printer is designed for high-grade bond (copy) paper, like the type widely used for ordinary xerographic copiers. It will also support other types of paper as long as they meet the standards explained in this chapter.

Selecting the right paper is very important. Use of unsuitable paper can cause paper jams, misfeed, curling, poor print quality, and even worse, printer damage. This chapter shows you how to use your printer in a way that will ensure efficient, error-free printing and minimal printer damage. This practice will increase your office productivity.



Note

Kyocera Mita will not be liable for any problems that may occur if you use paper that does not meet these standards.

2.1.1 Available paper types

The FS-C8026N can use almost any type of printer paper. These printers accept paper used for xerographic copiers as well.

Paper comes in three generic grades: economy, standard, and premium. The grades are determined by how easily the paper can pass through the printer. This depends on the smoothness, size, moisture content, and cutting of the paper. The higher the grade, the less risk of problems (such as paper jams), and higher the print quality.

The differences in paper characteristics of different paper makers also affect the printer performance. High-performance printers can produce high-quality results only when the right types of paper are selected. Low-priced paper is not always economical, especially if it ends up causing frequent printing problems.

Paper of the different grades is available in basis weights (explained later). The recommended basis weights of paper for the printers are 16, 20, and 24 pounds. When expressed in grams per square meter, the recommended basis weights range from 60 to 105 g/m².

2.1.2 Paper specifications

Table 2-1 summarizes the basic paper specifications. Details are given on the subsequent pages.

Item	Values
Weight (basis weight)	Cassette: 60 to 105 g/m ² (16 to 28 lb/ream) MP tray: 60 to 220 g/m ² (16 to 58 lb/ream) [†]
Thickness	0.086 to 0.110 mm (3.4 to 4.3 mils)
Dimensions	See <i>Table 2-2</i> .
Dimensional accuracy	±0.7 mm (±0.0276 inches)
Squareness of corners	90 ±0.2 °
Moisture content	4 to 6 %

Table 2-1

Item	Values
Direction of grain	Long grain
Pulp content	80 % or more

Table 2-1 (Continued)

† 135 to 200 g/m² paper should be A4 or Letter size and fed laterally.

2.1.3 Minimum and maximum paper sizes

The minimum and maximum paper sizes are as follows. For non standard paper such as cut-sheet, the MP (multi-purpose) tray must be used.

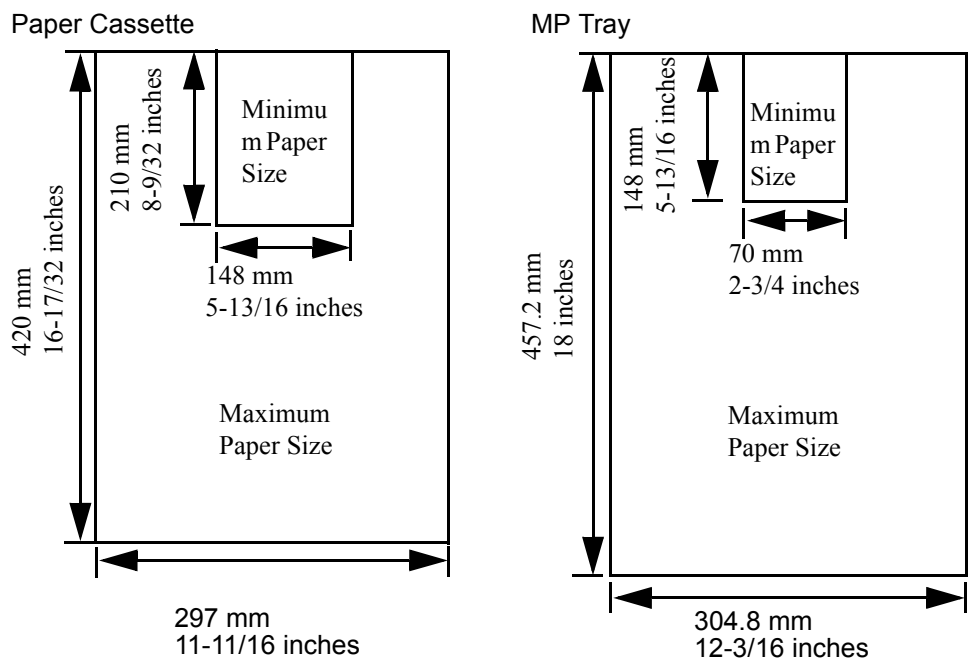

Figure 2-1

2.2 Selecting the Right Paper

This section describes the major considerations for selecting the right printing paper.

2.2.1 Guidelines

Paper conditions

Do not use paper with folded edges, curls, warps, smudges, tears, or embossing. Also do not use paper containing lint, clay, or paper debris. Using such paper may cause illegible printing, misfeeds, paper jams, etc., and shorten the product life of the printer. Never use paper with surface coating or other surface treatment. The paper surface should be as smooth and even as possible.

Paper composition

Do not use paper with surface-coating or containing plastic or carbon. The heat of fusing causes such paper to emit toxic fumes.

Bond paper should have at least an 80 % pulp content. The percentage of cotton and other fibers should not exceed 20 %.

Paper sizes

Table 2-2 lists the standard paper sizes and dimensions. Note that certain paper sizes are available only for MP tray feeding (as remarked) and face-up tray delivering. For details on using MP tray, see *Chapter 3 Using the Operator Panel, section 3.10.1 MP Tray Mode on page 3-48*.

The dimensional tolerances for these paper sizes are ± 0.7 mm (± 0.0276 inches) for both length and width of paper. The corner angles must be $90 \pm 0.2^\circ$.

MP tray	Size
Monarch	3-7/8 × 7-1/2 inches
Business	4-1/8 × 9-1/2 inches
Commercial #9	3-7/8 × 8-7/8 inches
Commercial #6-3/4	3-5/8 × 6-1/2 inches
ISO DL	110 × 220 mm
ISO C5	162 × 229 mm
ISO A6	105 × 148 mm
JIS B6	128 × 182 mm

Table 2-2

MP tray	Size
ISO B5	176 × 250 mm
12 × 18	12 × 18 inches
Statement	5-1/2 × 8-1/2 inches
Hagaki	100 × 148 mm
Oufuku Hagaki	148 × 200 mm
Youkei 2	114 × 162 mm
Youkei 4	105 × 235 mm
Custom	70 × 148 mm to 297 × 431 mm
Cassette or MP tray	Size
Ledger	11 × 17 inches
Legal	8-1/2 × 14 inches
Letter	8-1/2 × 11 inches
Executive	7-1/4 × 10-1/2 inches
Folio	210 × 330 mm
ISO A3	297 × 420 mm
ISO A4	210 × 297 mm
ISO A5	148 × 210 mm
JIS B5	182 × 257 mm
JIS B4	257 × 364 mm
ISO C4	229 × 324 mm
Oficio II	8-1/2 × 13 inches
8K	273 × 394 mm
16K	197 × 273 mm

Table 2-2 (Continued)

2.2.2 Paper properties

Smoothness

Paper should have a smooth, uncoated surface. Paper with a rough or sandy surface can cause gaps in printouts. However, paper with surfaces that are too smooth may cause multiple-sheet feeding and fogging problems (fogging is a gray background effect).

Basis weight

Basis weight is the weight in pounds of 500 sheets (called a ream) of paper cut to the basic size, which is 17 × 22 inches. The number of sheets in a ream and the basic paper size relating to basis weights depend on paper classifications. In the metric system, the basis weight is expressed in grams per square meter (g/m²).

Paper that is too heavy or too light may cause misfeeds, jams, and premature wear of printer parts. Uneven weight of paper can cause multiple-sheet feeding, print defects, poor toner fusing, blurring, and other print quality problems. The recommended basis weights for this printer are between 60 and 105 g/m² (16 to 28 lb per ream) for the paper cassette, and 60 and 220 g/m² (16 to 59 lb per ream) for the MP (Multi Purpose) tray.

Paper weight equivalence table

The paper weight is listed with expression in U.S. bond weight (lb) and European metric (g/m²). The shaded point indicates the standard weight.

U. S. Bond Weight (lb)	Europe Metric Weight (g/m ²)
16	60
17	64
20	75
21	80
22	81
24	90
27	100
28	105
32	120
34	128
36	135
39	148
42	157
43	163
47	176
53	199

Table 2-3

Thickness (Caliper)

Thick paper is called high-caliper paper and thin paper is called low-caliper paper. Paper used by the printer should be neither too thick nor too thin. If you encounter paper jam, multiple-sheet feed, or too light printing problems, the paper may be too thin. If you encounter paper jam or too heavy printing problems, the paper may be too thick. The recommended thickness of a sheet for this printer is between 0.086 and 0.110 mm (from 3.4 to 4.3 mils).

Moisture content

Moisture content is the percentage of the weight of water in paper. Moisture affects the appearance, feeding, curling, electrostatic properties, toner fusing of the paper.

The moisture content of paper varies with the relative humidity in the room. If the room is too humid, paper will absorb more moisture. The edges will swell and the paper will become wavy. If the room is too dry and the paper loses moisture, the edges shrink and tighten, and the print contrast may be degraded.

Wavy or tight edges can cause paper misfeeds and misalignments. The recommended moisture content is between 4 and 6 %.

To maintain the correct moisture content level, store the paper in an environment that allows moisture control. These are tips for moisture control:

- Store paper in a cool, dry place.
- Leave packages of paper wrapped as long as possible. Rewrap unused paper.
- Return paper to its paper carton, whenever possible. Place the cartons on a pallet or other furniture so that they are not in direct contact with the floor.
- Before using paper stored for an extended period of time, condition it in the printer's environment for at least 48 hours.
- Do not expose paper to heat, direct sunlight, or damp.

Grain

Technically, grain is the direction of paper in the paper machine. Grain is parallel with the direction of movement in the paper machine. Grain long means that the grain runs along the length of the sheet, and grain short means that the grain runs along the width of the sheet. Because grain short causes paper feed problems, always select grain long for the printers.

2.2.3 Other properties of paper

Porosity

The density of paper structure, which indicates the compactness of the fiber bonding. It is also the characteristic that allows air to pass through paper (i.e., air permeability).

Stiffness

The ability of paper to resist deformation under stress. In the printer, limp paper can buckle and too stiff paper can bind. Both conditions result in paper jams.

Curl

Most paper naturally tends to curl one way. To produce flat printouts, load the paper sheets so that the upward pressure from the printer can correct their curling. When loading paper, it is also important to distinguish between the front side and backside of the paper. Be sure to follow the paper loading instructions printed on the paper carton.

Electrostatic discharge

During the printing process, paper is given an electrostatic charge to attract the toner. Therefore, the paper must discharge the static electricity so that the printouts do not stick to each other in the output tray.

Whiteness

The contrast of printed images depends on the whiteness of the paper. Whiter paper produces sharper and clearer images.

Quality control

Uneven paper sizes, corners that are not square, jagged paper edges, irregularly cut sheets, torn edges and corners, etc. can cause various printer troubles. Before purchasing paper, find out whether the paper store always takes measures to prevent such problems in its products.

Packaging

Paper sheets should be shipped in strong cartons to protect them from damage during transportation. Before purchasing paper, make sure the store ships its products in proper packages.

Specially processed paper

Avoid using the types of specially processed paper listed below, even if the paper meets the other basic specifications defined in this manual. Be sure to perform some test prints before purchasing any type of paper in large quantities.

- Shiny paper
- Very thin paper
- Rough paper
- Perforated paper

2.3 Loading Paper

The following explains the procedure for loading paper in the paper feed cassette and the MP tray.



Fan the paper, then tap it on a level surface. This avoid media jams or skewed printing.

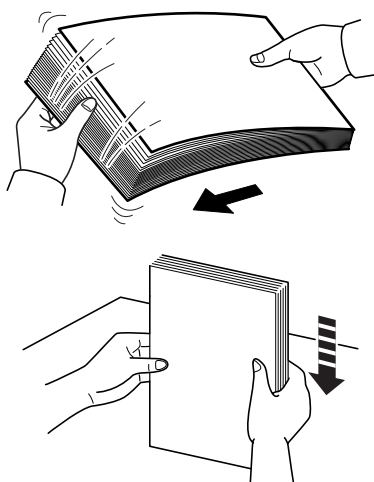

Figure 2-2

2.3.1 Loading paper into the cassette

Perform the following procedure to load paper into the paper feed cassette.

- 1** Slowly pull out the paper feed cassette until it paper feed stops.
- 2** Adjust the position of the paper guides according to the size of the paper you will use.

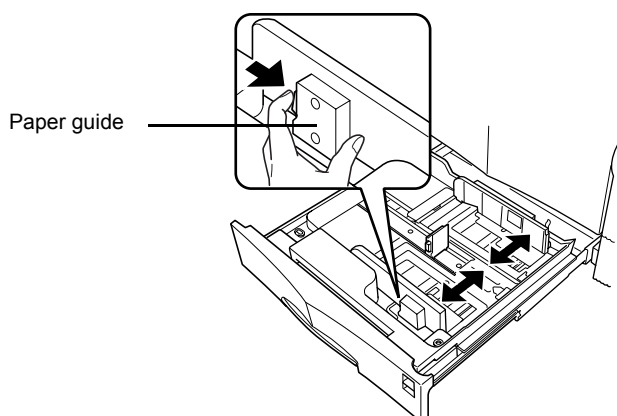

Figure 2-3

- 3** Adjust the position of the paper stopper according to the size of the paper you will use. While pressing the green button on the side of the paper stopper, slide it to the position you want.

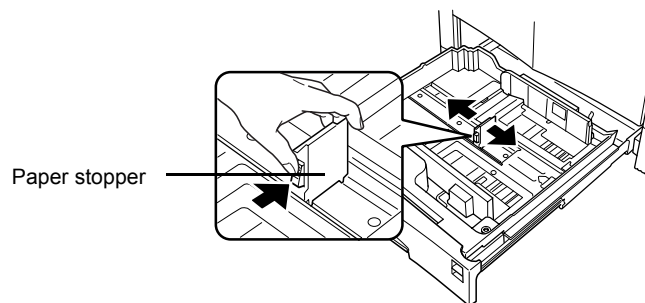

Figure 2-4

- 4** Square the edges of the paper and then insert it into the paper feed cassette. Make sure that the height of the stack does not exceed the upper limit line. The paper feed cassette can hold up to about 500 sheets. Printing is performed on the side of the paper that is facing down as it lies in the paper feed cassette.

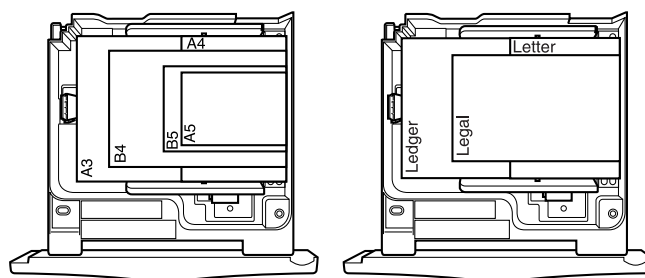

Figure 2-5

- 5** Slide the paper feed cassette into the printer.

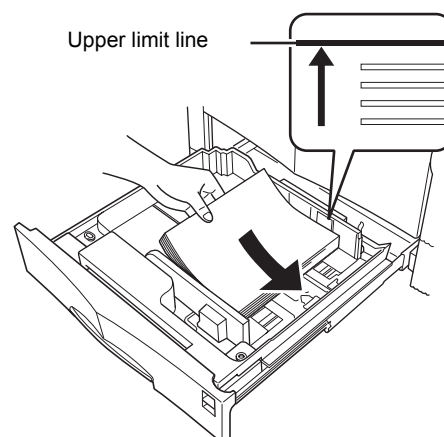

Figure 2-6

2.3.2 Loading paper into the MP (Multi-Purpose) tray

Perform the following procedure to load paper into the MP tray.

- 1 Open the MP tray located on the right side of the printer.

Adjust the length of the tray according to the side of paper you will use.

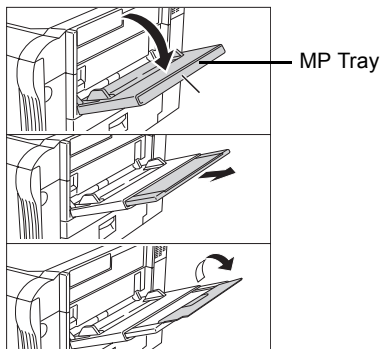

Figure 2-7

- 2 Adjust the position of the paper guides according to the size of the paper you will use.

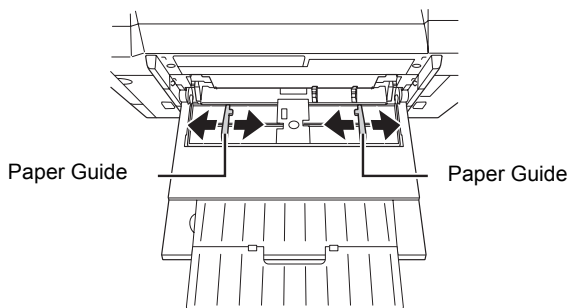

Figure 2-8

- 3 Square the edges of the paper and then carefully place it onto the MP tray.

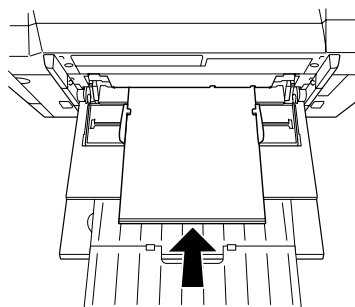

Figure 2-9

- 4 Set the MP tray paper size on the printer's operator panel. Refer to *Chapter 3 Using the Operator Panel, section 3.10.2 Setting MP Tray Paper Size on page 3-48.*

To close the MP tray, remove all of the paper from it, slide the paper guides as far apart as they will go, and then close the tray.

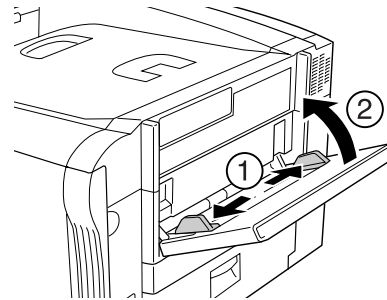

Figure 2-10

2.4 Special Paper

Besides plain paper, this printer can use the following types of special paper:

Paper type to be used	Media type to be selected
Thin paper (60 to 64 g/m ²)	Vellum
Thick paper (105 to 220 g/m ²)	Thick
Overhead projector transparencies	Transparency
Postcards	Cardstock
Envelopes	Envelope
Labels	Labels
Recycled paper	Recycle
Colored paper	Color
Preprinted paper	Preprint

Table 2-4



Note

When printing on A4 size paper with thickness above 200g/m², feed the paper sideways from the MP tray. Landscape feeding can cause paper jams.

You can assign one of these special paper type to a paper cassette or MP (multi-purpose) tray by using the printer's operator panel keys. Then, the printer can automatically select the paper cassette or multi-purpose tray to feed the special paper from and internally adjust the electrical parameters for optimum printing performance according to the special paper type. For details, see [3.10.4 Setting the Cassette Paper Type on page 3-50](#).

Note that some types of special paper do not allow feeding from the paper feeder cassette or duplex (two-sided) printing.

2.4.1 Selecting the special paper

Since special paper differs significantly in paper composition and quality, special paper is more likely to cause problems than white bond paper during printing. When using special paper, be sure that they are manufactured for photocopiers and/or printers.



Note

Kyocera Mita shall not be liable for any danger to a person or machine that is caused by using special paper (e.g., fumes emitted from the special paper).

Before purchasing any special paper, make a test print using the printer and check whether the results are satisfactory.

To avoid problems, stack transparencies, labels, or envelopes on the tray or cassette face up.

Major considerations for each type of special paper are given below.

Transparency

Transparencies for overhead projectors must withstand the heat of fusing during the printing process. The recommended transparency product is as follows:

3M CG3700 (Letter, A4)

To avoid problems, always feed OHP transparencies from the Multi-purpose tray and output them to the optional Face Up Tray.

When unloading transparencies (e.g., for clearing jams), hold them carefully by the edges to avoid leaving fingerprints on them.

Adhesive-backed labels

Label paper must be fed manually.

For printing on labels, use extreme care so that the adhesive may not come in direct contact with any part of the printer. Adhesives that stick to the drum or rollers will cause printer damage.

Labels consist of three parts. Printing is done onto the top sheet (also called the face sheet). The adhesive contains chemicals. The carrier sheet (also called the backing paper or liner) bears the top sheet. This composition of labels can cause more problems than other print forms during printing.

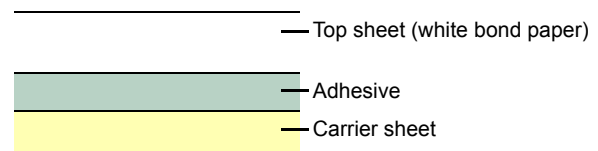

Figure 2-11

When using label paper, do not leave gaps between the arranged labels (i.e., top sheets). Labels arranged with gaps in-between can easily be peeled off during printing, causing serious jam problems.

2.4 Special Paper

When the label paper has extra margin around the label's outside edges that correspond to the margins of the printable area, do not remove the extra top sheet from the carrier sheet until printing is finished.

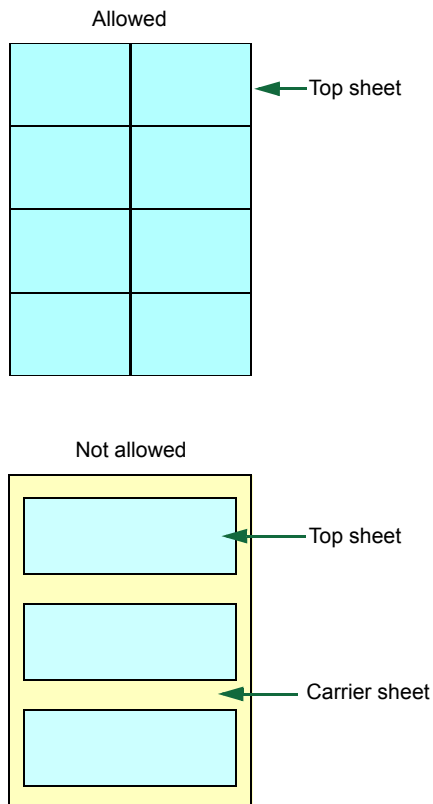

Figure 2-12

When selecting labels, make sure to use only those meeting the following requirements:

Item	Value
Top sheet weight	44 to 74 g/m ² (12 to 20 lb)
Total weight	104 to 151 g/m ² (28 to 40 lb)
Top sheet thickness	0.086 to 0.107 mm (3.9 to 4.2 mils)
Total thickness	0.115 to 0.145 mm (4.5 to 5.7 mils)
Moisture content	4 to 6 % (composite)

Table 2-5

Postcards

Fan the stack of postcards and align the edges before loading them in the MP tray. Make sure the postcards you are going to set are not curled. Feeding curled postcards may cause paper jams.

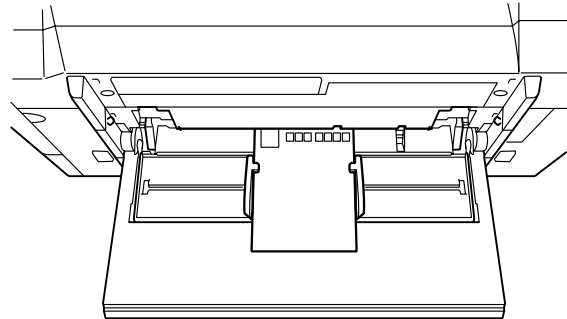

Figure 2-13

Some postcards have rough edges on the back (those are created when the paper is cut). In this case, put the postcards on a flat place and rub the edges with, for example, a ruler to smooth them.

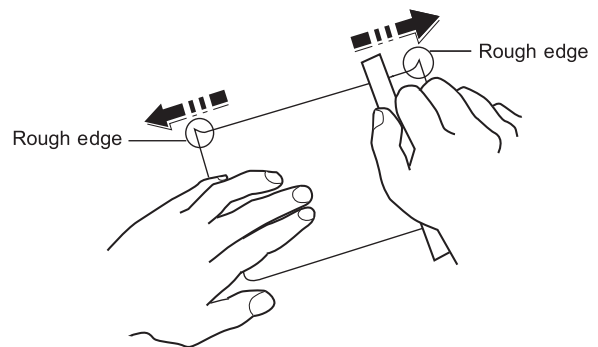

Figure 2-14

Envelopes

Envelopes must be fed manually.

Since the composition of an envelope is more complex than that of ordinary paper, it is not always possible to ensure consistent printing quality over the entire envelope surface.

Normally, envelopes have a diagonal grain direction. See section [Grain on page 2-5](#). This direction can easily cause wrinkles and creases when envelopes pass through the printer. Before purchasing envelopes, make a test print to check whether the printer accepts the envelope.

Other handling cautions follow:

- Do not use envelopes that have an encapsulated liquid adhesive.
- Avoid a long printing session for envelopes only. Extended envelope printing can cause premature printer wear.
- To avoid jams caused by curled envelopes, stack the printed envelopes no higher than 10 on the output tray.

Colored paper

Colored paper should have the same specifications as the white bond paper listed. In addition, the pigments in the paper must be able to withstand the heat of fusing during the printing process (up to 200 °C or 392 °F).

Pre-printed paper

Pre-printed paper should basically be bond paper. The inks on the paper must be able to withstand the heat of fusing during the printing process and must not be adversely affected by silicon oil. Do not use paper with any kind of coating, such as calendar stock.

Recycled paper

Select recycled paper that has the same specifications as white bond paper. See [Table 2-1 on page 2-2](#). Recycled paper, however, does not have to be as white as white bond paper.



Note

Before purchasing recycled paper, make a test using the printer and check whether the print quality is satisfactory.

Chapter 3 Using the Operator Panel

This chapter provides the information you need to configure the Ecosys Color printer. In general you need to use the operator panel only to make default settings. You can make most changes to the printer settings using the printer driver through the application software.



Note

Changes to printer settings made using a software application override changes made using the operator panel.

You can also rely on other printer utilities such as Kyocera Mita PrintMonitor if you need to change settings that are not available on the printer driver. It will allow you remote access to printer settings. Printer utilities are supplied in the CD-ROM supplied with the printer.

The chapter describes the operator panel in detail, including its menus and the procedures for changing various printer settings.

3.1 Understanding the Operator Panel

The printer's operator panel has keys for operating the printer, as well as a message display and indicators

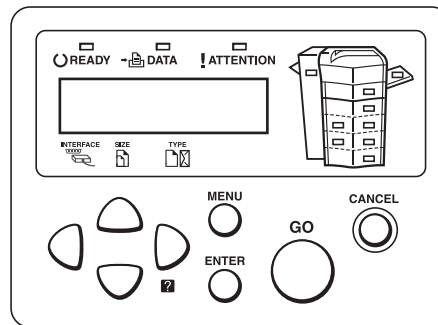

Figure 3-1

Messages that appear on the display and functions of indicators and keys are explained in the sections that follow.

3.1.1 Message display

The message display on the operator panel shows:

- Status information, the eight messages listed below which are displayed during normal operation.
- Error codes, when the printer requires the operator's attention; as explained in [Chapter 4 Troubleshooting](#).

Status information

Message	Meaning
Self test	The printer is performing self-diagnostics after power-up.
Please wait	The printer is warming up and is not ready. When the printer is switched on for the first time, this message will take several minutes.
Please wait (Calibrating)	The color calibration function is being performed automatically as you powered on the printer. You can also execute this function manually on the operator panel. For details, see 3.13.15 Color Calibration on page 3-65 .
Please wait (Adding toner)	Toner is currently being replenished. This message may be displayed during continuous printing of a large volume of pages which require a large amount of toner such as with photographs, etc.
Ready	The printer is ready to print.
Processing	The printer is receiving data to print. This is also shown when the printer is reading a memory card or hard disk.

Table 3-1

Message	Meaning
Sleeping	The printer is in sleep mode. The printer wakes from sleep mode whenever a key on the operator panel is pressed, the cover is opened or closed, or a print job is received. The printer then warms up and goes on-line. For details on sleep mode, see <i>Sleep timer timeout on page 3-59</i> .
Cancelling data	Jobs inside the printer are being canceled. To cancel a job, see <i>Section 3.1.3 Keys on page 3-6</i> .
Waiting	The printer is waiting for the rest of print job before completing the last page. Pressing the GO key allows you to obtain the last page immediately. See below.
FormFeed TimeOut	The printer is printing the last page after a waiting period.

Table 3-1 (Continued)

Error codes

See *Chapter 4 Troubleshooting*.

3.1.2 Indicators in message display

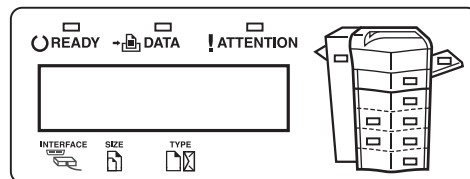

Figure 3-2

Interface indicator (INTERFACE)

The interface indicator shows the interface that is currently in use:

PAR	Parallel interface is in use.
NET	Network interface is in use.
OPT	Option network interface is in use.
SER	Option serial (RS-232C) interface is in use.
---	No interface is in use.

Each interface has a timeout time of 30 seconds during which the other interface should wait to receive a print job. Even a print job has been complete on the interface, you should wait for this period until the other interface begins printing the job.

Paper size indicator (SIZE)

This indicator indicates:

- While the printer is in standby, the paper size of the cassette. The default paper cassette is determined by the operator panel keys. For details, see [Section 3.10 Paper Handling on page 3-48](#).
- While the printer is printing, the paper size used to format the document to print by the application software.

The abbreviations used to indicate the paper sizes and their dimensions are as follows:

A3	ISO A3 (29.7 × 42 cm)
A4	ISO A4 (21 × 29.7 cm)
A5	ISO A5 (14.8 × 21 cm)
A6	ISO A6 (10.5 × 14.8 cm) [†]
B4	JIS B4 (25.7 × 36.4 cm)
B5	JIS B5 (18.2 × 25.6 cm)
B6	JIS B6 (12.8 × 18.2 cm) [†]
LT	Letter (8-1/2 × 11 inches)
LD	Ledger (11 × 17 inches)
LG	Legal (8-1/2 × 14 inches)
MO	Monarch (3-7/8 × 7-1/2 inches) [†]
BU	Business (4-1/8 inches) [†]
DL	ISO DL (11 × 22 cm) [†]
C4	ISO C4 (22.9 × 32.4 cm) [†]
C5	ISO C5 (16.2 × 22.9 cm) [†]
b5	ISO B5 (17.6 × 25 cm) [†]
EX	Executive (7-1/4 × 10-1/2 inches) [†]
#6	Commercial 6-3/4 (3-5/8 × 6-1/2 inches) [†]
#9	Commercial 9 (3-7/8 × 8-7/8 inches) [†]
HA	Japanese Postcard (10 × 14.8 cm) [†]
OH	Return Postcard (20 × 14.8 cm) [†]
O2	Oficio II (8-1/2 × 13 inches) [†]
12	12 × 18 (12 × 18 inches) [†]
8K	8 kai (27.3 × 39.4 cm) [†]
16K	16 kai (19.7 × 27.3 cm) [†]
ST	Statement (5-1/2 × 8-1/2 inches) [†]
FO	Folio (21 × 33 cm) [†]
Y2	Yokei 2 (11.4 × 16.2 cm) [†]
Y4	Yokei 4 (10.5 × 23.5 cm) [†]
CU	Custom Size (7 × 14.8 cm to 29.7 × 43.1 cm) [†]

[†] Only with MP tray feeding

Paper type indicator (TYPE)

This indicator shows the paper type defined for the current paper cassette. The paper type can be manually defined using the operator panel. For information about configuring paper type settings, see [3.10.9 Creating Custom Paper Types on page 3-53](#), [3.10.3 Setting the MP Tray Paper Type on page 3-49](#), and [3.10.4 Setting the Cassette Paper Type on page 3-50](#).

The following abbreviations are used:

(none)	Auto
PLAIN	Plain paper
TRANSPRNCY	Transparencies [†]
PREPRINTE	Pre-printed paper
LABELS	Labels
BOND	Bond paper [†]
RECYCLED	Recycled paper
VELLUM	Vellum
ROUGH	Rough paper [†]
LETTERHEA	Letterhead
COLOR	Colored paper
PREPUNCH	Pre-punched paper
ENVELOPE	Envelopes [†]
CARDSTOCK	Card stock [†]
COATED	Coated paper
THICK	Thick paper
HIGH QUAL	High-quality paper
CUSTOM1 (to 8)	Custom 1 (to 8)

[†] MP tray feeding only

READY, DATA, and ATTENTION indicators

The following indicators light during normal operation and whenever the printer needs operator's attention. Depending on the status of lighting, each indicator has the following meaning:



Indicator	Description
 READY	<p>Flashing. Indicates an error that you can recover by yourself, such as the loose front cover. For details, see 4.3 Error Messages on page 4-6.</p> <p>On. Indicates that the printer is ready and on-line. The printer prints the data it receives.</p> <p>Off. Indicates that the printer is off-line. Data can be received but will not be printed until the printer is on-line by pressing the GO key. Also, indicates when printing is automatically stopped due to the occurrence of an error. For details see 4.3 Error Messages on page 4-6.</p>
 DATA	<p>Flashing. Indicates that a data is being received from the computer.</p> <p>On. Indicates either that data received is being processed before printing starts, or that data received is being written to a memory card or a hard disk.</p>
 ATTENTION	<p>Flashing. Indicates that the printer requires maintenance or is warming up.</p> <p>On. Indicates the occurrence of a problem or an error. For details, see 4.3 Error Messages on page 4-6.</p>

Table 3-2

3.1.3 Keys

The operator panel keys are used to configure the printer operation. Note that certain keys have the secondary function as explained below.



Configuration made with these keys affect only the interfaces that is currently active (indicated by the INTERFACE indicator on the message display). See [Interface indicator \(INTERFACE\)](#) on page 3-3.

GO key



The **GO** key switches the printer between on-line and off-line. Use this key to:

- Toggle the printer's on-line and off-line states. You can temporarily stop the print job by switching the printer off-line.
- Print and feed out one page when the printer displays `Waiting`.
- Recover the printer from certain errors

CANCEL key



This key is used to:

- Cancel a printing job
- Stop the alarm sound
- Reset numeric values or cancels a setting procedure while using menu system

To cancel a printing job:

- 1** While the printer displays `Processing`, press the **CANCEL** key.

`Print Cancel?` appears on the message display followed by the interface which the job to cancel is on. The interface is indicated by one of the following message:

```
Parallel  
Network  
Option (option network interface)  
Serial (option serial interface)
```

- 2** Press the **ENTER** key. `Cancelling data` appears on the message display and printing stops after the current page is printed.

MENU key



The **MENU** key lets you enter the menu system to change the setup and printing environment of the printer.

Pressing this key during a menu selection will terminate the selection and return the printer to the normal operation.

Arrow keys

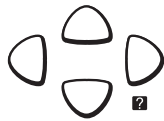

The four arrow keys are used in the menu system to access a desired item or enter numeric values.

The arrow key with the question mark (?) may be pressed when the paper jam message has appeared on the message display. Then a help message will appear to facilitate jam clearing in the location.

ENTER key



This key is used to:

- Finalize settings of numeric values and other selections.
- Set the paper source when `Use alternative?` is shown in the message display. For details about this message, see [.4.3 Error Messages on page 4-6](#)



If you hold down the ENTER key and press the MENU key when Ready is shown on this printer, the AdministrationID menu will be displayed. This menu invokes the account management system and is normally not used. To cancel invoking the menu, press the MENU key to return to the Ready display.

3.2 Using the Menu Selection System

3.2.1 Menu Selection System

This section explains how to use the menu selection system. The **MENU** key on the operator panel allows you to use the menu to set or change the printer environment such as the number of copies to print, emulation, etc., to your specific needs. Settings can be made when Ready is indicated on the printer message display.

The printer obeys the most recently received printer settings sent from the application software, or from the printer driver, which take priority over operator panel settings.

Entering the mode selection menu

Press the **MENU** key when Ready is indicated on the printer message display.

The mode selection menu is displayed.

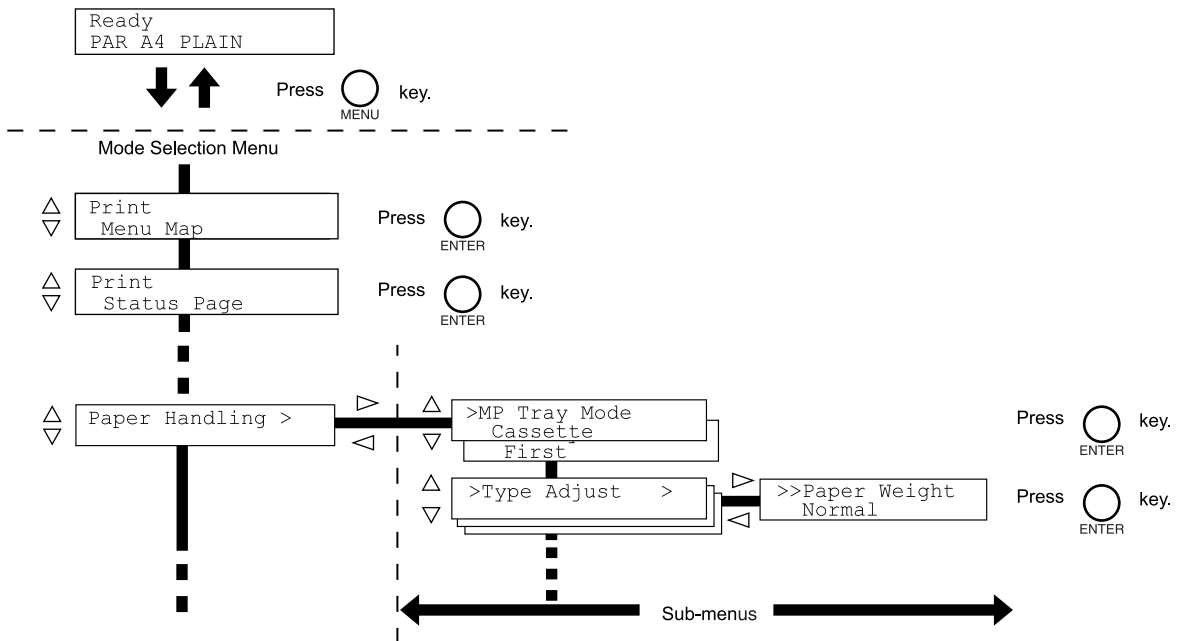

Selecting a menu

The mode selection menu is hierarchical. Press the Δ or ∇ key to display the desired menu.

- If the selected menu has a sub-menu, > is displayed after the menu.

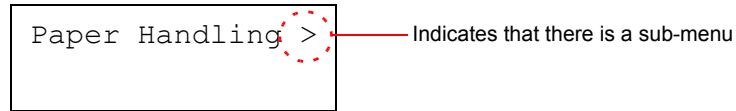

Press the \triangleright key to move to the sub-menu or \triangleleft key to go back.

- > is displayed before the sub-menu.

Indicates that this is the sub-menu

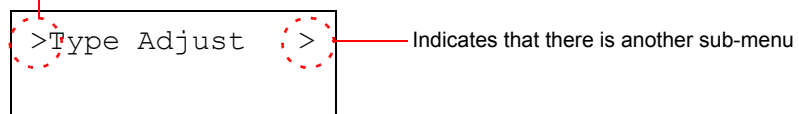

Press the \triangleright key to move to another sub-menu or \triangleleft key to go back.

- >> is displayed before the second sub-menu.

Indicates that this is the second sub-menu

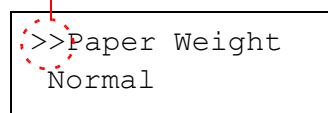

Setting a menu

Select the desired menu and press the **ENTER** key to set or change the configuration.

Press the Δ or ∇ key to display the desired item and the **ENTER** key to finalize the value or selections set.

Cancelling menu selection

If you press the **MENU** key when selecting a menu, the message display returns to Ready.



Note

Settings that are received from application software and the printer driver will take priority over settings made in the operator panel.

3.2.2 Menu System Road Map

The following is the hierarchy diagram of the menu selection system of the printer.

For details about menu selection operations, see [page 3-8](#).

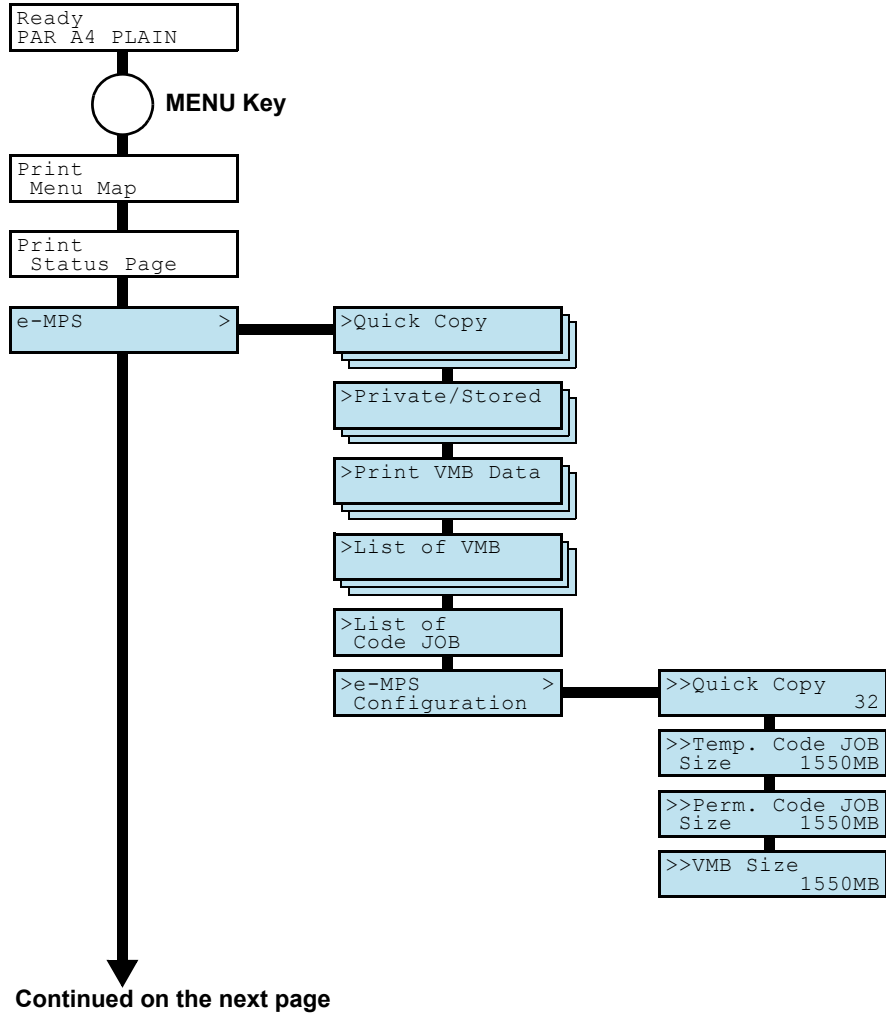

These items will not appear unless the printer is installed with the applicable option unit.

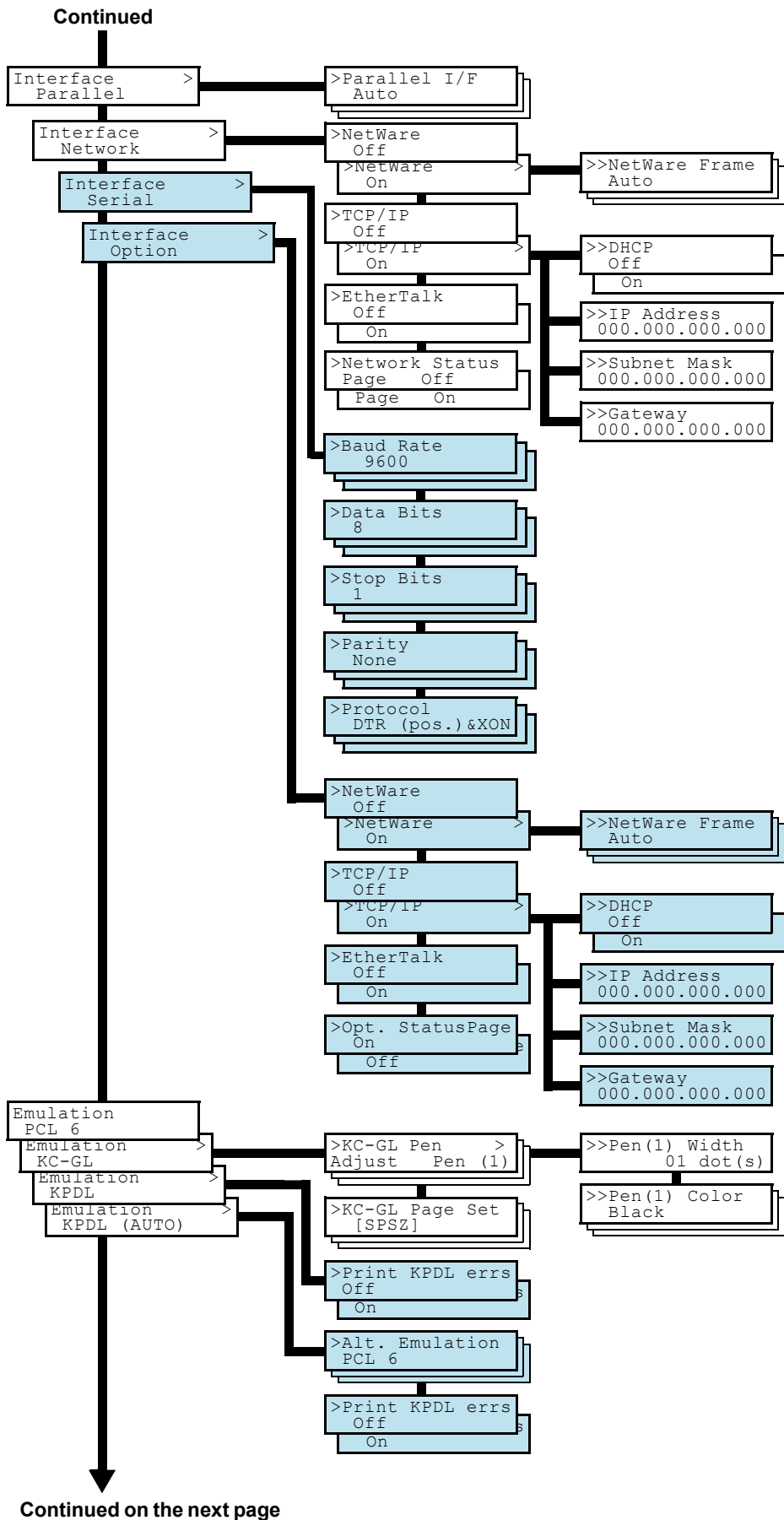

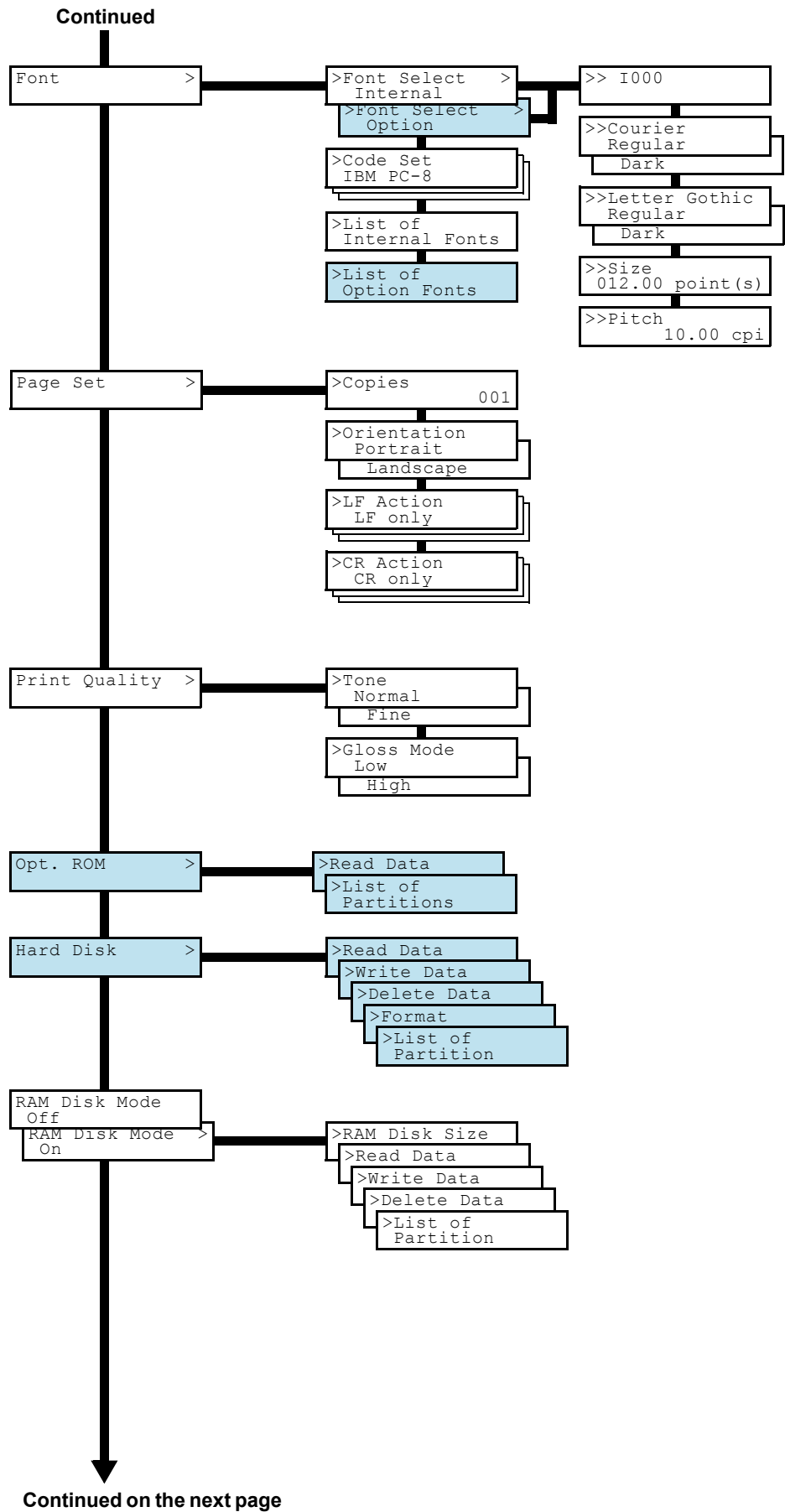

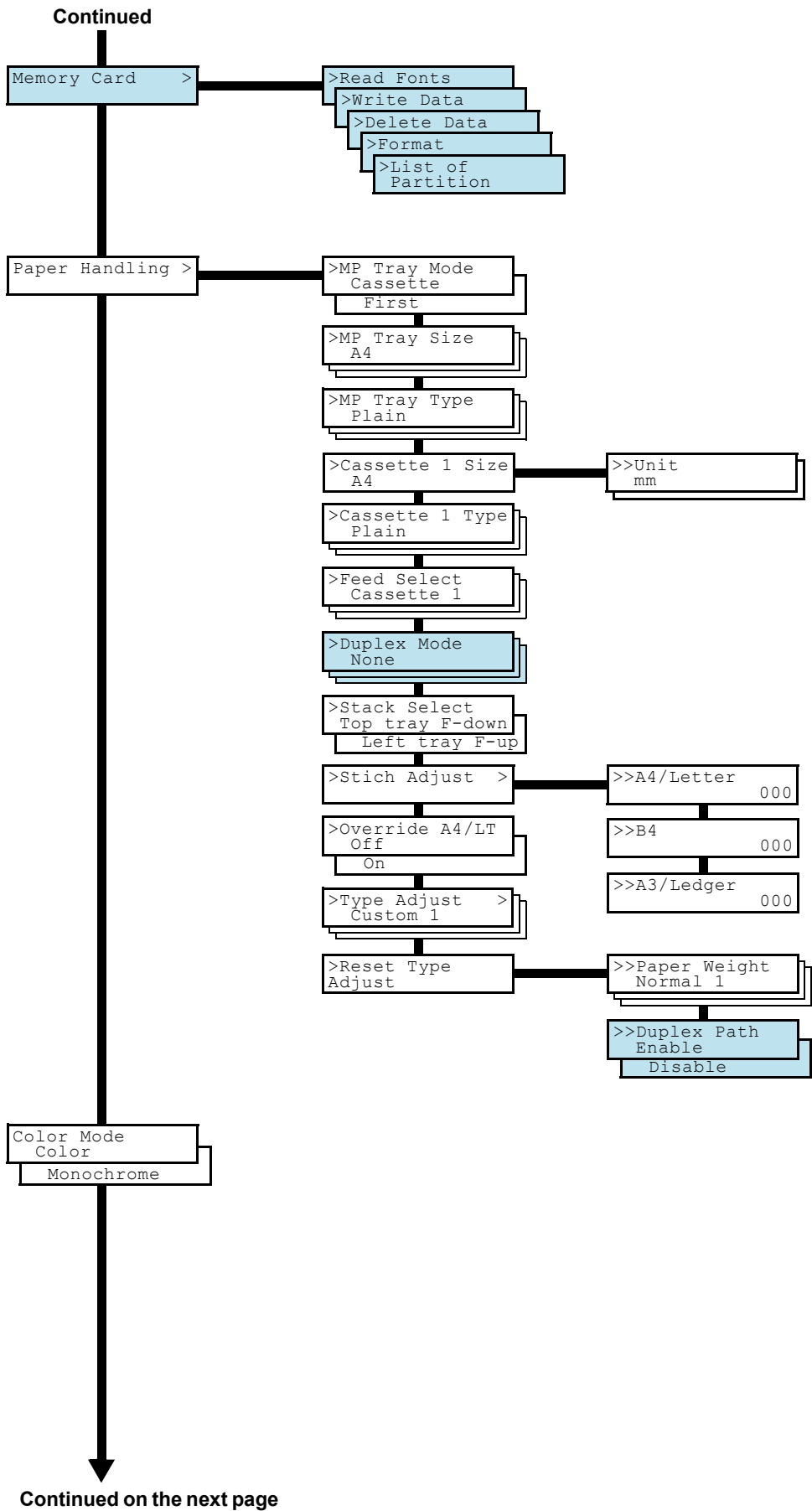

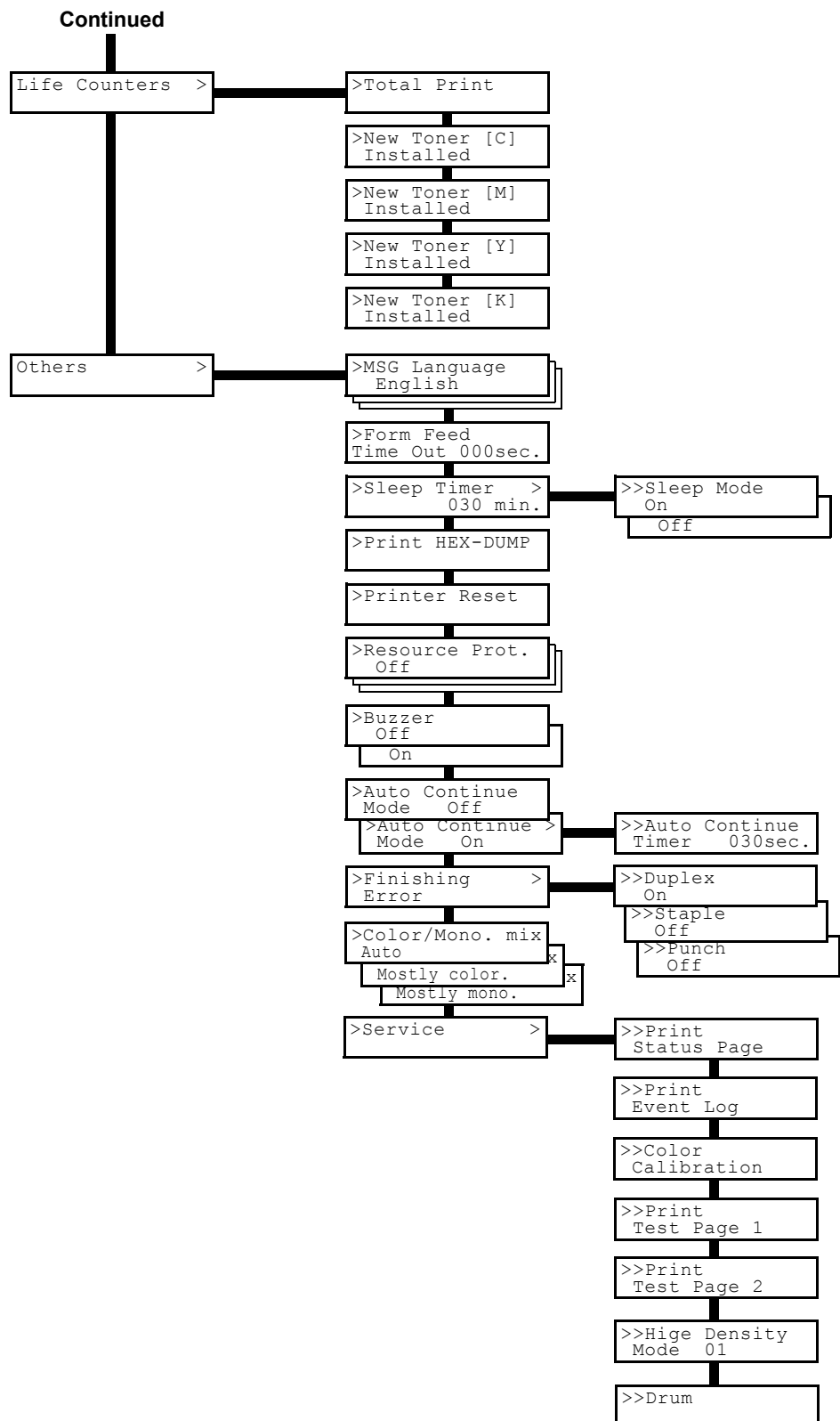

3.3 Menu Map and Status Pages

This section explains the procedure for printing the printer's internal information using the menu selection system. The menu map is useful as a reference to guide yourself through the menu selection system.

The status page is a list of parameters and settings for most basic printer configurations. You may be required to produce a status page when requesting service to the printer.

3.3.1 Printing a Menu Map

The printer prints a full list of menu selection system — Menu Map. Note that menus shown in the list may vary depending on which optional units installed in the printer.

- 1 Press the **MENU** key.
- 2 Press the Δ or ∇ key repeatedly until `Print Menu Map` appears.

```
Print
Menu Map
```

- 3 Press the **ENTER** key. A question mark (?) appears.

```
Print
Menu Map ?
```

- 4 Press the **ENTER** key. The message `Processing` appears and the printer prints a Menu Map.

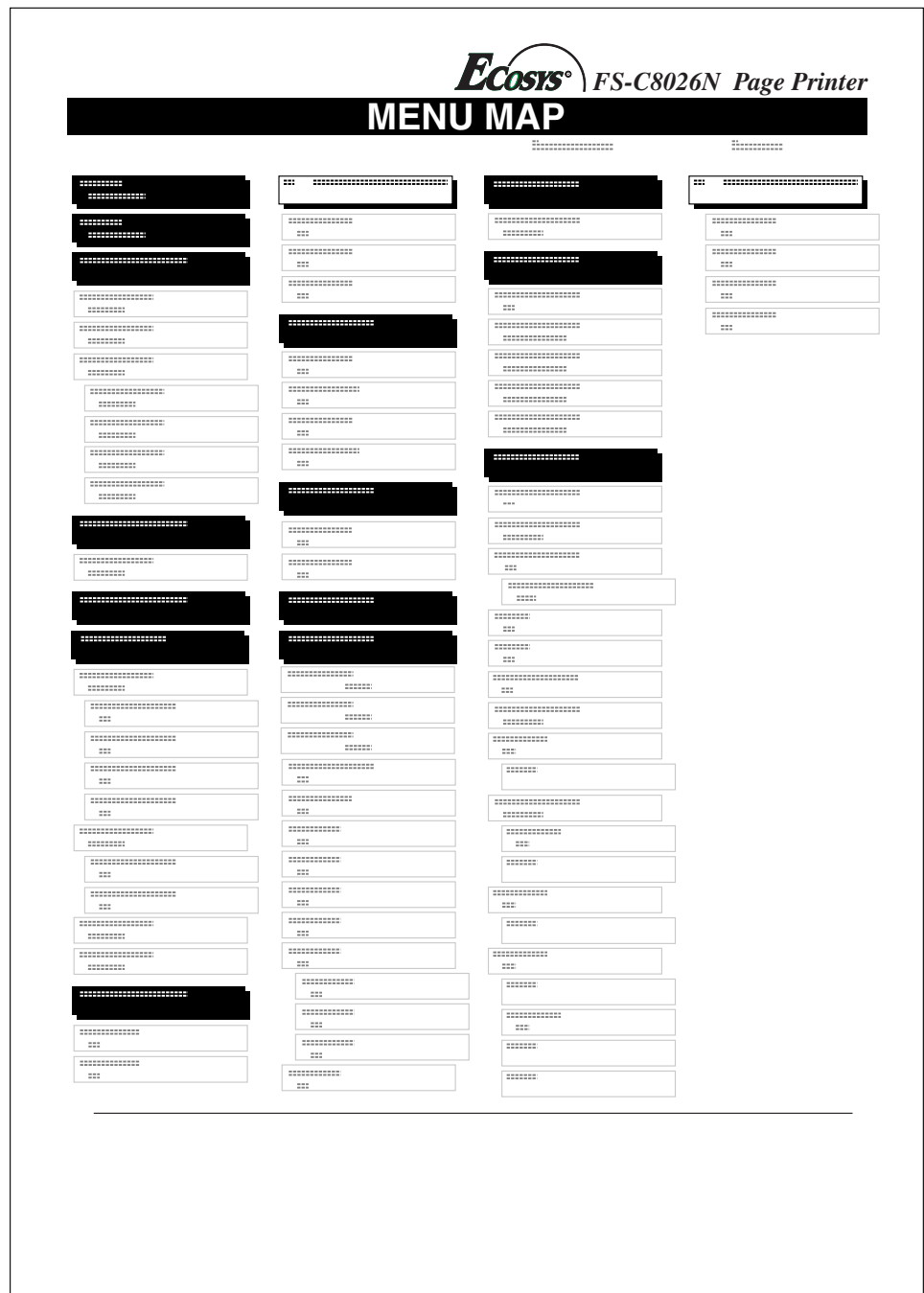

Figure 3-3

3.3.2 Printing a Status Page

You can check the printer's current status, including available memory space and option settings by printing a status page.

- 1** Press the **MENU** key.
- 2** Press the Δ or ∇ key repeatedly until `Print Status Page` appears.

```
Print
Status Page
```

- 3** Press the **ENTER** key. A question mark (?) appears.

```
Print
Status Page ?
```

- 4** Press the **ENTER** key again. The message `Processing` appears and the printer prints a status page.

For a sample status page and its full description, see [Understanding the status page on page 3-18](#).

Understanding the status page

The numbers in the following diagram refer the items explained below the diagram. The items and values on the status page may vary depending on the printer's firmware version.

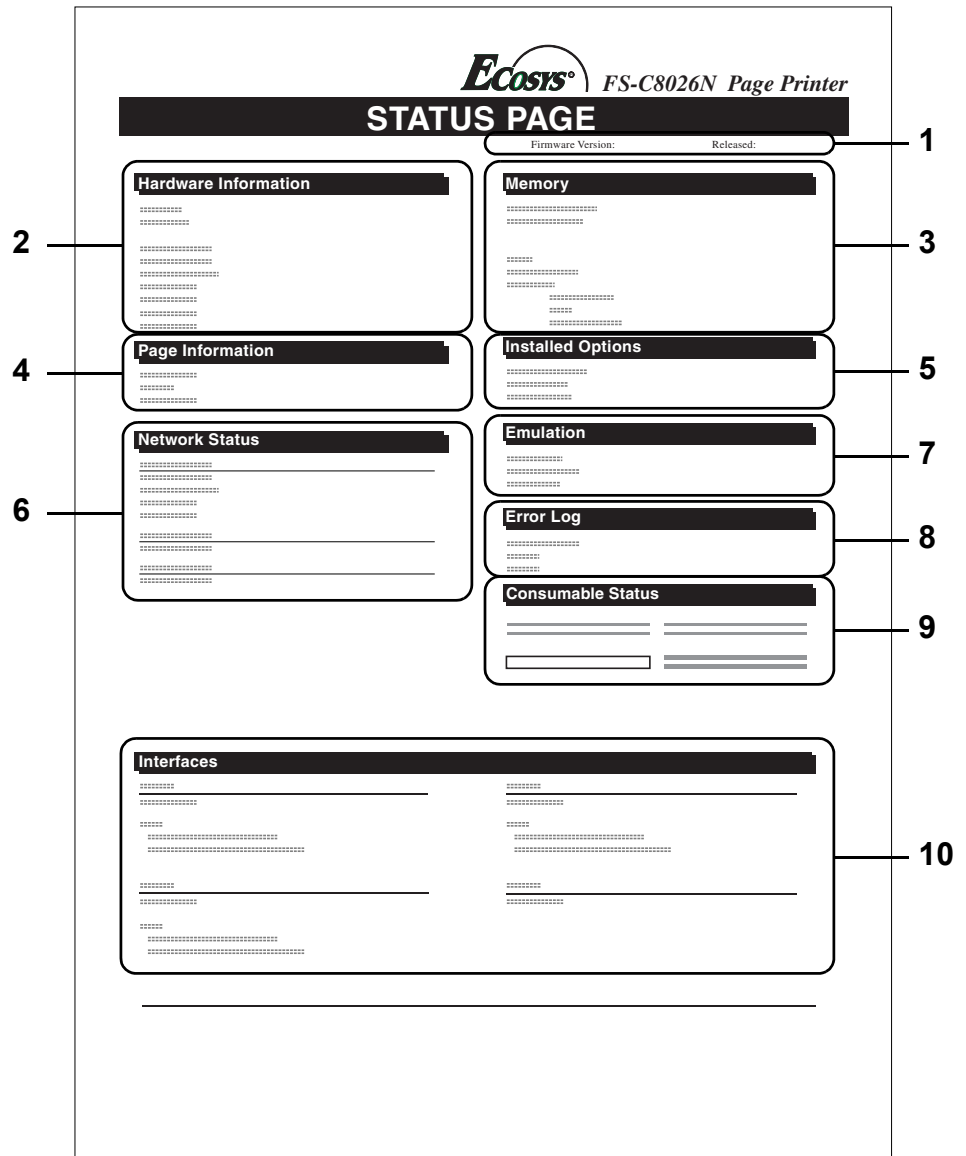

Figure 3-4

1 Software version

This item shows the version and release date of the printer firmware.

2 Hardware information

This item shows various printer settings for hardware-related items:

- MP tray paper size and type
- Paper cassette size and type
- Buzzer control
- Host buffer size
- Sleep time timeout time
- Formfeed timeout time

3 Memory

This item shows:

- Standard memory in the printer (128 MB)
- Option memory slot status (Slots 1 and 2) in megabytes
- Total memory in the printer
- Current status of the RAM disk

4 Page information

This item shows the page related items:

- Tone mode, Normal or Fine
- Number of copies, from 1 to 999
- Total page count

5 Installed options

This item shows the options installed in the printer:

- Hard disk
- Option ROM
- Memory card

6 Network status

This item shows the IP address, subnet mask address, and default gateway address for the network interface card in the printer.

7 Emulation

This item shows all available emulations of the printer. The PCL 6 emulation is set as default when the printer is shipped from the factory. The emulations are:

- PCL 6
- KPDL3
- KC-GL

8 Error log

This item shows the last three instances of the following types of errors, listing them in the order of occurrence:

- KPDL (PostScript) errors
- Memory overflow
- Print overrun
- File-not-found

The most recent error is displayed on the topmost line of Error Log. Error information is cleared when the printer is powered off.

The error log information is intended for service purpose.

9 Consumable status

This item shows the approximate level of remaining toner. When the value is 100, the toner container is full. The closer to 0, the smaller the amount of remaining toner.

10 Interface information

This information shows the emulation and the default font for all interfaces installed in the printer.

3.4 e-MPS

e-MPS is an abbreviation for ‘enhanced-Multiple Printing System’ which implements the following functions that are available from the printer driver:

- Job retention
- Job storage

In either job mode, when printing a document, the print data is transferred from the computer to the printer then stored on the printer’s hard disk. Since copies of the document are printed using the stored data, printing is performed faster with less computer spooling time and less network traffic.



Note

- **To use the e-MPS system, an optional hard disk (HD-10) must be installed in the printer.**
- **As an alternative to a hard disk, the RAM disk may be used in the Proof-and-Hold and Private Print modes. To activate the RAM disk in the printer, see [Using the RAM Disk on page 3-46](#).**

Job retention

Job Retention has four modes as summarized below. These modes are selected when you choose on the printer driver through the application software:

	Quick Copy	Proof-and-Hold	Private Print	Stored Job
Primary function	To later print additional copies	To proof the first copy before printing multiple copies	To hold the document in printer to prevent unauthorized access	To electronically store documents such as fax cover pages
Start storing by	Printer driver	Printer driver	Printer driver	Printer driver
On terminating print setting from application software	Prints simultaneously	Prints one copy simultaneously	Does not print	Does not print
Retrieved by	Operator panel	Operator panel	Operator panel	Operator panel
Default number of copies printed at retrieval	Same as storing (can be changed)	One less (can be changed)	Same as storing (can be changed)	One
Maximum number of jobs stored [†]	32, expandable to 50	32, expandable to 50	Depends on the hard disk capacity (Private jobs are deleted automatically once it is retrieved.)	Depends on the hard disk capacity
PIN security	No	No	Yes	Yes (if necessary)
Data after printing	Stored	Stored	Deleted	Stored
Data at power off	Deleted	Deleted	Deleted	Stored
Hard disk required	Yes	No	No	Yes

Table 3-3

[†] A job exceeding this number will be overwritten to the earliest one.

Job storage

Job storage stores print jobs either temporarily or permanently, or in virtual mailboxes, as you click an appropriate radio button on the printer driver when printing from a computer.

Virtual mailbox

Virtual mailbox is part of Job Storage, which stores print jobs on the hard disk without printing. It enables you to retrieve jobs later from the operator panel.

Each mailbox may be used by an individual who desires to share the printer in this mode. By default, each mailbox is numbered from 'Tray 001,' 'Tray 002,' ... etc. To 'post' a job in one of these mailboxes, you assign a numbered or named mailbox on the printer driver when printing.

To retrieve the stored job for printing, see [Retrieving Jobs from Virtual Mailbox \(VMB\) on page 3-24](#).



Note

The virtual mailbox can be used in PCL 6 emulation only.

3.4.1 Using Quick Copy

This mode enables you to print the requested number of copies of a job, simultaneously storing the job on the hard disk. When additional copies are required, you can reprint the required number of copies from the printer operator panel. To print a job as a quick copy job, see [KX Printer Drivers Operation Guide](#).

The default number of print jobs that can be stored on the hard disk is 32. This value can be increased to up to 50 from the e-MPS Configuration menu. For details, see [Changing the maximum number of Quick Copy/Proof-and-Hold jobs on page 3-25](#). When the number of jobs reaches the limit, the oldest job will be overwritten by the new one.

When the printer is turned off, all stored jobs will be deleted.

Printing additional copies using quick copy

To print additional copies of a job stored in the printer:

- 1 Press the **MENU** key.
- 2 Press the Δ or ∇ key repeatedly until e-MPS > appears.

```
e-MPS >
```

- 3 Press the \triangleright key.
- 4 Press the Δ or ∇ key repeatedly until >Quick Copy appears followed by the user name (Harold, in this example). The user name is assigned at printing using the printer driver.

```
>Quick Copy
Harold
```

- 5 Press the **ENTER** key. A blinking question mark (?) appears before the user name.

```
>Quick Copy
?Harold
```

- 6 Press the Δ or ∇ key to display the desired user name, Arlen, in this example.

```
>Quick Copy
?Arlen
```

- 7 Press the **ENTER** key. The job name entered in the printer driver (Report, in this example) appear with a blinking question mark (?) before the letters.

```
>Arlen
?Report
```

- 8 Press the Δ or ∇ key to scroll to the desired job title.

- 9 Press the **ENTER** key. The number of copies to be printed can be set. To increase the copy count, press the Δ key; to decrease the copy count, press the ∇ key.

```
>Report
Copies 001
```

- 10 Press the **ENTER** key to finalize the copy count. The printer prints the specified number of copies for the job.

Deleting a quick copy job

All quick copy jobs are automatically deleted when the printer is turned off. If you desire to explicitly delete a stored quick copy job, proceed as follows:

- 1** Follow steps 1 through 8 in the above section to let the title of the job to be deleted displayed.
- 2** When the title of the job to be deleted is displayed, e.g. `Report`, below, press the **ENTER** key. The cursor below the copy count starts to blink.

```
>Report
Copies      001
```

- 3** Press the ∇ key repeatedly until `Delete` appears below the title.

```
>Report
Delete
```

- 4** Press the **ENTER** key. The stored quick copy job is deleted.

3.4.2 Using Proof-and-Hold

When you print multiple copies, this mode first prints one copy so that you can proof it before continuing to print the remaining copies. Since you can proof the printouts before printing the remaining copies, wastage of paper can be reduced.

The printer prints one copy and, at the same time, saves the print job on the hard disk/RAM disk. You can also change the number of copies when resuming printing from the operator panel.

When the printer is turned off, all stored jobs will be deleted.

Printing remaining copies of a Proof-and-Hold job

Printing a Proof-and-Hold job on the operator panel is similar to printing a quick copy job. See *Printing additional copies using quick copy on page Chapter 3-21*.

3.4.3 Printing a Private Print/Job Retention

In private printing, you can specify that a job is not printed until you release the job from the operator panel. At sending the job from the application software, you can specify a 4-digit access code in the printer driver. The job is released for printing by entering the access code on the operator panel. Thus, this function ensures confidentiality of the print job.

In the job retention mode, access codes are not mandatory, but can be set on the printer driver if printing with the PIN security is required. Then, the access code must be entered on the operator panel to print a stored job. Print data will be stored in the hard disk/RAM disk after printing. See *KX Printer Drivers Operation Guide* for the driver settings.

Releasing a private/stored job

- 1** Press the **MENU** key.
- 2** Press the Δ or ∇ key repeatedly until `e-MPS >` appears.

```
e-MPS      >
```

- 3** Press the \triangleright key.
- 4** Press the Δ or ∇ key repeatedly until `>Private/ Stored` appears. The name entered in the printer driver (`Harold`, in this example) also appears.

```
>Private/ Stored
Harold
```

- 5** Press the **ENTER** key. A blinking question mark (?) appears before the user name.

```
>Private/ Stored
?Harold
```

- 6** Press the Δ or ∇ key to display the desired user name (`Arlen`, in this example).

```
>Private/ Stored
?Arlen
```

- 7** Press the **ENTER** key. The user name and the job name (Agenda, in this example) entered in the printer driver appear with a blinking question mark (?).

```
>Arlen
?Agenda
```

- 8** Press the Δ or ∇ key to display the desired job title.

- 9** Press the **ENTER** key. The ID input line appears. Enter the four-digit access code entered in the printer driver and press the **ENTER** key.

```
>Agenda
ID      0000
```

To enter the ID, press the \triangleleft or \triangleright key to move the cursor to the number to be changed and then enter the correct number by pressing the Δ or ∇ key.

- 10** You can set the number of copies to be printed. To increase the copy count, press the Δ key; to decrease the copy count, press the ∇ key.

```
>Agenda
Copies  001
```

- 11** Press the **ENTER** key to finalize the copy count. The printer prints the specified number of copies for the job.

Deleting a private/stored job

You can individually delete stored jobs by performing the following procedure. Jobs saved using Private Print will be automatically deleted if you turn the power off after printing, but jobs saved using Stored Job will not be deleted automatically.

- Follow steps 1 through 8 in the above section.
- When the title of the job to be printed is displayed (Agenda, in this example), press the **ENTER** key. Enter the four-digit access code entered in the printer driver and press the **ENTER** key.

```
>Agenda
Copies  001
```

- 3** Press the ∇ key repeatedly until **Delete** appears for the number of copies.

```
>Agenda
Delete
```

- 4** Press the **ENTER** key. The private job is deleted from the hard disk.

Printing a code job

Install the KM-NET Job Manager software from the CD-ROM supplied with the printer. To do this, from the CD-ROM **Main Menu**, select **Printer Utilities > Install KM-NET Job Manager**.

- Browse through Windows **Start > Programs > KYOCERA MITA > KM-Net > Job Manager**.
- Enter the password for the software. **Job Manager** will start.
- Click the **Add printer** icon (below). Select the **Local** or **Network** port.



Note

If you use the local parallel port to connect to the printer, make sure that the printer driver is set to print to a local port. To check this out, click the **Details** tab of the printer **Properties**, and note the **Print to the following port** setting.

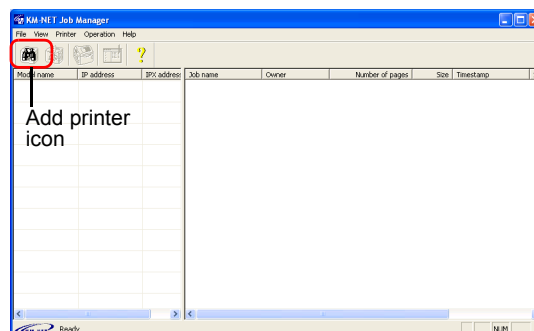

Figure 3-5

- 4** Follow the wizard until the **Select printer** dialog box is reached. When the printer is found in the **Printer List**, click (highlight) it, then **Finish**.

- 5 Double click **Model Name** on the list. The jobs currently stored in the printer are shown. To print the job, right click **Job name** and then click **Print** on the drop down list that appears.

It is possible to select more than one job at a time by left clicking a job one by one while pressing the **Ctrl** key on the computer keyboard.

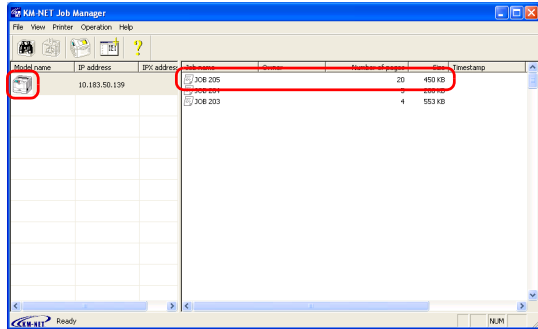

Figure 3-6

The job remains intact even after printing. To permanently delete the job in the hard disk, right click the job name on **Job Manager**, then click **Delete** on the drop down list that appears.

Printing a list of code jobs

If you select Permanent Job Storage on the printer driver, you can have a List of Code Job printed using the operator panel.

- 1 Press the **MENU** key.
- 2 Press the Δ or ∇ key repeatedly until e-MPS > appears.



- 3 Press the \triangleright key.
- 4 Press the Δ or ∇ key repeatedly until >List of Code JOB appears.

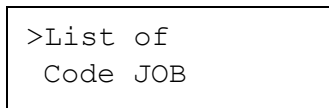

- 5 Press the **ENTER** key. A question mark (?) appears.

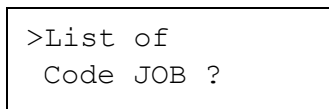

- 6 Press the **ENTER** key again. The printer prints a CODE JOB LIST as shown in Figure 3-7 below.

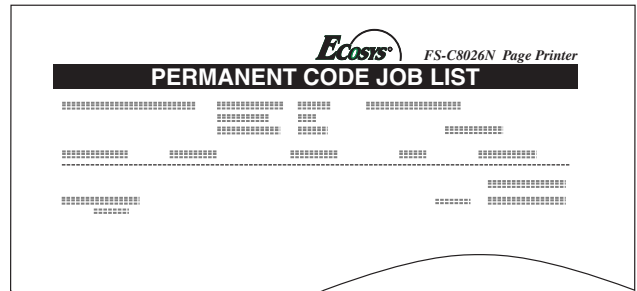
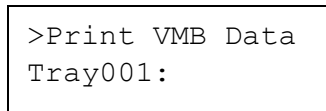
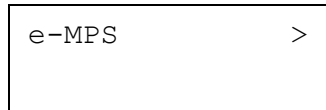

Figure 3-7

3.4.4 Retrieving Jobs from Virtual Mailbox (VMB)

To retrieve the jobs posted in the virtual mailbox, proceed as follows.

- 1 Press the **MENU** key.
- 2 Press the Δ or ∇ key repeatedly until e-MPS > appears.
- 3 Press the \triangleright key.
- 4 Press the Δ or ∇ key repeatedly until >Print VMB Data appears. The virtual mailbox number will also appear.



If you have named the virtual mailbox with an alias on the printer driver, the alias (Richard, in this example) will follow the number:

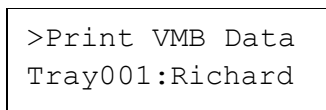

- 5** Press the **ENTER** key. A blinking question mark (?) appears.

```
>Print VMB Data
Tray001?Richard
```

- 6** Press the **ENTER** key. The document in the mailbox is printed and automatically deleted from the mailbox.

Printing a list of VMB

A Virtual Mailbox list includes the jobs currently stored in the mailboxes.

- 1** Press the **MENU** key.
- 2** Press the Δ or ∇ key repeatedly until e-MPS > appears.

```
e-MPS >
```

- 3** Press the \triangleright key.
- 4** Press the Δ or ∇ key repeatedly until >List of VMB appears.

```
>List of VMB
```

- 5** Press the **ENTER** key. A question mark (?) appears.

```
>List of VMB ?
```

- 6** Press the **ENTER** key again. The printer prints a list of jobs currently posted in the virtual mailboxes as shown in *Figure 3-8* below.

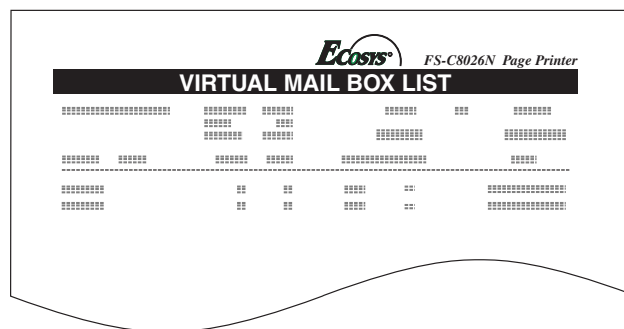

Figure 3-8

3.4.5 Changing e-MPS Configuration

You can change the following parameters for e-MPS operation:

- Maximum number of Quick Copy/Proof-and-Hold jobs
- Maximum space assigned to temporary code jobs
- Maximum space assigned to permanent code jobs
- Maximum space assigned to virtual mailboxes



Note

The total amount of storage areas specified must not exceed the total size of the hard disk. Otherwise, you may only be able to accommodate print jobs of a smaller amount of print jobs than specified.

Changing the maximum number of Quick Copy/Proof-and-Hold jobs

This changes maximum number of Quick Copy/Proof-and-Hold jobs from 0 to 50. The default is 32.

- 1** Press the **MENU** key.
- 2** Press the Δ or ∇ key repeatedly until e-MPS > appears.

```
e-MPS >
```

- 3** Press the \triangleright key.

- 4** Press the Δ or ∇ key repeatedly until `>e-MPS Configuration >` appears.

```
>e-MPS      >
Configuration
```

- 5** Press the \triangleright key.

- 6** Press the Δ or ∇ key repeatedly until `>>Quick Copy` appears.

```
>>Quick Copy
                32
```

- 7** Press the **ENTER** key. A blinking cursor (`_`) appears.

```
>>Quick Copy
                32_
```

- 8** Press the Δ or ∇ key to increase or decrease the value at the blinking cursor. The value can be set between 0 and 50. Use the \triangleright and \triangleleft keys to move the cursor right and left.

- 9** When the desired maximum number of jobs is set, press the **ENTER** key.

- 10** Press the **MENU** key. The display returns to Ready.

Maximum space assigned to temporary code jobs

This changes the hard disk space that holds temporary code jobs. You can change the maximum space from 0 to 9999 (megabytes). The actual maximum size depends on the size of free hard disk space, however. The default size is 1/6 of the total hard disk space, rounded off in unit of 50 MB. For example, if the total hard disk space is 10 GB, the default size is 1550 MB.

- 1** Press the **MENU** key.

- 2** Press the Δ or ∇ key repeatedly until `e-MPS >` appears.

```
e-MPS      >
```

- 3** Press the \triangleright key.

- 4** Press the Δ or ∇ key repeatedly until `>e-MPS Configuration >` appears.

```
>e-MPS      >
Configuration
```

- 5** Press the \triangleright key.

- 6** Press the Δ or ∇ key repeatedly until `>>Temp. Code JOB Size` appears.

```
>>Temp. Code JOB
Size          1550MB
```

- 7** To change the maximum disk space, press the **ENTER** key. A blinking cursor (`_`) appears.

```
>>Temp. Code JOB
Size          1550MB_
```

- 8** Press the Δ or ∇ key to increase or decrease, respectively, the value at the blinking cursor. Use the \triangleright and \triangleleft keys to move the cursor right and left.

- 9** When the desired size is displayed, press the **ENTER** key.

- 10** Press the **MENU** key. The display returns to Ready.

Maximum space assigned to permanent code jobs

This changes the hard disk space that holds permanent code jobs. You can change the maximum space from 0 to 9999 (megabytes). The actual maximum size depends on the size of free hard disk space, however. The default size is 1/6 of the total hard disk space, rounded off in unit of 50 MB. For example, if the total hard disk space is 10 GB, the default size is 1550 MB.

- 1** Press the **MENU** key.

- 2** Press the Δ or ∇ key and select `e-MPS >`.

```
e-MPS      >
```

- 3** Press the \triangleright key.

- 4** Press the Δ or ∇ key and select >e-MPS Configuration >.

```
>e-MPS      >
Configuration
```

- 5** Press the \triangleright key.

- 6** Press the Δ or ∇ key and select >>Perm. Code JOB Size.

```
>>Perm. Code JOB
Size      1550MB
```

- 7** Press the **ENTER** key, the message display shows a blinking cursor (|).

```
>>Perm. Code JOB
Size      1550MB|
```

- 8** Press the Δ or ∇ key to increase or decrease, respectively, the value at the blinking cursor. Use the \triangleright and \triangleleft keys to move the cursor right and left.

- 9** When the desired size is displayed, press the **ENTER** key.

- 10** Press the **MENU** key and the display returns to Ready.

- 4** Press the Δ or ∇ key and select >e-MPS Configuration >.

```
>e-MPS      >
Configuration
```

- 5** Press the \triangleright key.

- 6** Press the Δ or ∇ key and select >>VMB Size.

```
>>VMB Size
          1550MB
```

- 7** To change the maximum size, press the **ENTER** key. The message display shows a blinking cursor (|).

```
>>VMB Size
          1550MB|
```

- 8** Press the Δ or ∇ key to increase or decrease, respectively, the value at the blinking cursor. Use the \triangleright and \triangleleft keys to move the cursor right and left.

- 9** When the desired size is displayed, press the **ENTER** key.

- 10** Press the **MENU** key to exit the menu selection.

Maximum space assigned to virtual mailboxes (VMB)

This changes the hard disk space for virtual mailboxes. You can change the maximum space from 0 to 9999 (megabytes). The actual maximum size depends on the size of free hard disk space, however. The default size is 1/6 of the total hard disk space, rounded off in unit of 50 MB. For example, if the total hard disk space is 10 GB, the default size is 1550 MB.

- 1** Press the **MENU** key

- 2** Press the Δ or ∇ key and select e-MPS >.

```
e-MPS      >
```

- 3** Press the \triangleright key.

3.5 Changing the Interface Parameters

The printer is equipped with a parallel interface. Option network interface card can also be installed. Various printing environment parameters such as the default emulation can be changed independently on different interfaces by using the printer's menu selection system. Select the interface to apply the changes in the procedure described below.



Note

This interface selection described below does not select which interface to receive data from the computer. The printer automatically detects and switches to the interface on which data are being received.

3.5.1 Changing Parallel Interface Mode

The parallel interface supports a bi-directional/high-speed mode according to IEEE standards. Normally, this interface is used under the default setting `Auto`. For details, see [Appendix B Computer Interface](#). After setting the interface, be sure to reset the printer or turn the power off at least once. The new setting will be enabled thereafter. You can select from the following:

- Auto (default)
- Nibble/high speed
- High speed
- Normal

- 1 Press the **MENU** key.
- 2 Press the Δ or ∇ key repeatedly until `Interface >` appears.
- 3 If the interface is other than parallel, press the **ENTER** key. A blinking question mark (?) appears.

```
Interface
? Network
```

- 4 Press the Δ or ∇ key repeatedly until `Parallel` appears.

```
Interface
? Parallel
```

- 5 Press the **ENTER** key again. The question mark disappears.

- 6 To change the parallel interface mode, press the \triangleright key. The current communication mode appears.
- 7 To change the communication mode, press the **ENTER** key. A blinking question mark (?) appears.

```
>Parallel I/F
? Auto
```

- 8 Press the Δ or ∇ key to scroll through the following communication modes:

```
Auto
Normal
High Speed
Nibble (high)
```

- 9 When the desired communication mode is displayed, press the **ENTER** key.
- 10 Press the **MENU** key to exit the menu selection.

3.5.2 Changing Serial Interface Parameters



Note

This section applies to the printers having the option serial interface board kit (IB-11) installed.

You can confirm or change the serial interface parameters including baud rate, data bits, stop bits, parity, and protocol. These parameters must match those of the computer's serial interface.

- 1 Press the **MENU** key.
- 2 Press the Δ or ∇ key repeatedly until `Interface >` appears.
- 3 If the interface is other than serial, press the **ENTER** key. A blinking question mark (?) appears.

```
Interface
? Network
```

4 Press the Δ or ∇ key repeatedly until `Serial` appears.

```
Interface
? Serial
```

5 Press the **ENTER** key again.

6 Press the \triangleright key. One of the following serial parameters is indicated (`Baud rate` for example).

Pressing the Δ or ∇ key toggles through the serial parameters as follows. To change the serial parameter, press the **ENTER** key. Use the Δ or ∇ key to change the value or selection.

	Range
>Baud Rate 9600	1200, 2400, 4800, 9600 (Default), 19200, 38400, 57600, 115200
↓ ↑	
>Data Bits 8	7 or 8 (Default)
↓ ↑	
>Stop Bits 1	1 (Default) or 2
↓ ↑	
>Parity None	None (Default), Odd, Even, or Ignore
↓ ↑	
>Protocol DTR (pos.) & XON	DTR (pos.) & Xon (Default), DTR (positive), DTR (nega- tive), XON/XOFF, ETX/ACK

For example, to change baud rate from 9600 to 115200, display the baud rate menu following the above procedure. When the display shows baud rate, 9600 (bps), press the **ENTER** key. A blinking question mark (?) appears.

```
>Baud Rate
? 9600
```

Press the Δ or ∇ key to scroll through values. When 115200 is displayed, press the **ENTER** key. Press the **MODE** key to exit the menu selection.



Note Some computers may not be able to handle a baud rate of 115200 bps. If you set the baud rate to 115200 and encounter communication problems, select a lower baud rate.

3.5.3 Changing Network Interface Parameters

The printer has a built-in network interface which supports TCP/IP, NetWare and EtherTalk protocols. In addition, you can install an optional network interface card in the printer's extension slot (OPT).

To adjust the printer for networking parameters of the current network, using the operator panel, you can:

- Activate or deactivate TCP/IP, NetWare, and AppleTalk
- Activate or deactivate DHCP
- Enter IP address, subnet mask address, and default gateway address
- Determine whether to print a network status pages automatically when the printer is turned on

To confirm or change networking parameters, proceed as follows:

- 1** Press the **MENU** key.
- 2** Press the Δ or ∇ key repeatedly until `Interface >` appears.
- 3** If the current interface is other than network, press the **ENTER** key. A blinking question mark (?) appears.

```
Interface >
? Parallel
```

If the optional network interface card is installed in the printer, `Option` will be displayed. The setting procedure is basically the same even in this case.

4 Press the Δ or ∇ key repeatedly until `Network` appears.

```
Interface >
? Network
```

5 Press the **ENTER** key again.

6 Press the \triangleright key. One of the following menus is indicated. To change settings for the item, press the **ENTER** key. Use the \triangle or ∇ key to change the value or selection. Configure settings referring to the explanations below.

>NetWare > On	Set this item to On when you connect to a network using NetWare. In submenu (>), frame mode can be selected from Auto, 802.3, Ethernet II, 802.2, and 802.3SNAP.
↓ ↑	
>TCP/IP > On	Set this item to On when you connect to a network using TCP/IP. Submenu (>) has items including DHCP, IP address, subnet mask address, and gateway address. To resolve IP address for the network card, see 3.5.4 Resolving IP Address below.
↓ ↑	
>EtherTalk Off	EtherTalk must be activated (On) for networking with Macintosh computers.
↓ ↑	
>Network Status Page Off	When the item is set to On, the printer prints out a network status page when it prints the printer status. See Printing a network interface status pages on page 3-31 .

7 Activate the appropriate protocol that is required to connect the printer to the network. To activate a protocol, let the protocol displayed, press the **ENTER** key, press the \triangle or ∇ key to change from Off to On, and press the **ENTER** key.

8 Press the **MENU** key. The display returns to Ready. You can print a network status page to confirm that the IP address, subnet mask address, and the gateway address have been properly set. To print a network status page, see [Printing a network interface status pages on page 3-31](#) which follows.

3.5.4 Resolving IP Address

To connect the printer using TCP/IP protocol to a network in which a DHCP server is not present, you must manually set the IP address using the operator panel. The IP address must be unique to the printer and should be obtained from your network administrator.

1 Activate TCP/IP protocol in the manner described above.

>TCP/IP >
On

2 Enter the submenu by pressing the \triangleright key. Make sure that DHCP is set to Off. If not, press the **ENTER** key, then press \triangle key to set it Off. Each time you press the \triangle or ∇ key, the selection changes as shown below.

>>DHCP
Off



>>IP Address
000.000.000.000



>>Subnet Mask
000.000.000.000



>>Gateway
000.000.000.000

3 When >>IP Address is displayed, press the **ENTER** key. A blinking cursor ($_$) appears at the last digit.

>>IP Address
000.000.000.000

4 Press the \triangle or ∇ key to increase or decrease, respectively, the value at the blinking cursor. Use the \triangleright and \triangleleft keys to move the cursor right and left.

5 When the IP address is entered, press the **ENTER** key.

- 6 Press the Δ or ∇ key to move to Subnet Mask. Perform the same procedure to complete entering the subnet mask address.
- 7 Then, press the Δ or ∇ key to move to Gateway. Perform the same procedure to complete entering the gateway address.
- 8 Press the **MENU** key. The display returns to Ready. You can print a network status page to confirm that the IP address, subnet mask address, and the gateway address have been properly set. To print a network status page, see *Printing a network interface status pages* which follows.

Printing a network interface status pages

You can have your printer print out network status pages when the printer prints the standard status page. The network status pages shows the network addresses, and other information under various network protocols about the network interface. The default setting is Off (The printer does not print network status pages.).



Note

Network status pages may not be available to print depending on the type and make of the optional network interface card.

Sample network status pages are shown on *Figure 3-9 on page 3-31*.

- 1 Press the **MENU** key.
- 2 Press the **ENTER** key repeatedly until Interface > appears.

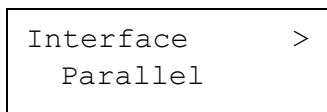

- 3 If the interface is other than network, press the **ENTER** key. A blinking question mark (?) appears.

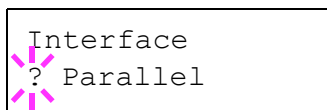

- 4 Press the Δ or ∇ key repeatedly until Network appears. Press the **ENTER** key.

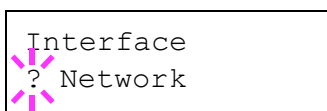

- 5 Press the \triangleright key and then press the Δ or ∇ key repeatedly until the display shows >Network Status Page.

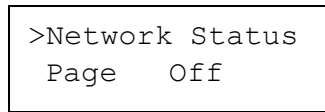

- 6 The default setting is Off. If it is set to On, press the **ENTER** key. A blinking question mark (?) appears.

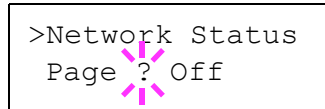

- 7 Press the Δ or ∇ key to select On.

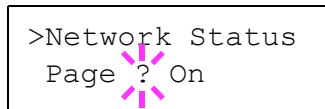

- 8 Press the **ENTER** key again.

- 9 Press the **MENU** key. The display returns to Ready. The printer prints network status pages as an example shown in *Figure 3-9* below.

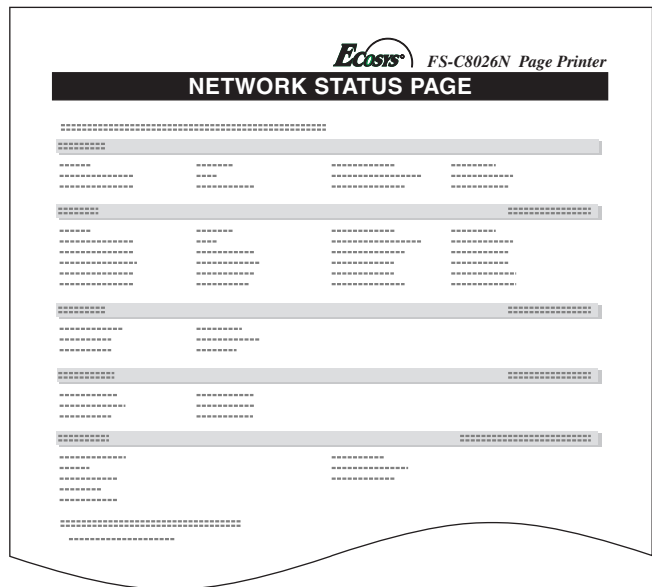

Figure 3-9

3.6 Making Default Settings

Using the operator panel, you can set the default for the most of printing parameters. Note default settings made using the operator panel may be overridden by the printer driver settings and application software.

3.6.1 Default Emulation

You can change the emulation mode and character code set for the current interface. The printer is capable of the following emulation modes:

- HP PCL 6 (HP Color LaserJet 8550)
- KC-GL (HPGL 7550A)
- KPDL3 (PostScript 3)

The printer can automatically switch between KPDL 3 and another emulation depending on the print job that is received from the computer. To do this, select **KPDL (AUTO)** in the following procedure and determine the alternative emulation by referring to [3.6.3 Alternative Emulation for KPDL Emulation on page 3-33](#).

- 1 Press the **MENU** key.
- 2 Press the Δ or ∇ key repeatedly until **Emulation >** appears on the message display. One of the emulation modes appears, indicating the emulation currently in use the default emulation is HP PCL 6.

```
PCL 6
KC-GL
KPDL
KPDL (AUTO)
```

- 3 To change the default emulation, press the **ENTER** key. A blinking question mark (?) appears.

```
Emulation
?PCL 6
```

- 4 Press the Δ or ∇ key repeatedly until the desired emulation mode is displayed.
- 5 Press the **ENTER** key.
- 6 Press the **MENU** key. The display returns to **Ready**.

3.6.2 KC-GL Pen Width and Color

The KC-GL emulation mode enables you to set the pen widths in dots, individual pen colors for pen numbers 1 to 8, and the KC-GL page size.

- 1 Press the **MENU** key.
- 2 Press the Δ or ∇ key repeatedly until **Emulation** appears on the message display.
- 3 If the current emulation is other than KC-GL, press the **ENTER** key. A blinking question mark (?) appears.
- 4 Press the Δ or ∇ key repeatedly until **KC-GL** appears. Press the **ENTER** key.

```
Emulation >
KC-GL
```

- 5 Press the \triangleright key to move to the **>KC-GL Pen Adjust >** submenu. To change the pen width and/or pen color, press the **ENTER** key. A blinking question mark (?) appears.

```
>KC-GL Pen
Adjust ? Pen (1)
```

- 6 Press the Δ or ∇ key repeatedly until the desired pen number of 1 to 8 appears. When the desired pen number is displayed, press the **ENTER** key.
- 7 To change the pen width, press the \triangleright key, then press the **ENTER** key. A blinking cursor appears at the width value.

```
>>Pen (1) Width
02 dot (s)
```

- 8 Press the Δ or ∇ key repeatedly until the desired pen width in dots (00 to 99) appears. When the desired pen width is displayed, press the **ENTER** key.

- 9** To set the pen color, press the Δ or ∇ key. To change the pen color, press the **ENTER** key. A blinking question mark (?) appears.

```
>>Pen (1) Color
? Black
```

- 10** Press the Δ or ∇ key repeatedly until the desired pen color (Black, Red, Green, Yellow, Blue, Magenta, Cyan, White) appears. When the desired pen color is displayed, press the **ENTER** key.

- 11** To set the KC-GL page size, press the \triangleleft key twice, then Press the Δ or ∇ key until >KC-GL Page Set is displayed.

- 12** To change the page size, press the **ENTER** key. A blinking question mark (?) appears.

```
>KC-GL Page Set
? [A2]
```

- 13** Press the Δ or ∇ key repeatedly until the desired page size (A2, A1, A0, B3, B2, B1, B0, and SPSZ) appears. The SPSZ command sets the paper edge limits to the dimensions of a standard paper size. See this command explained in the Programming Manual in the CD-ROM. Press the **ENTER** key to set the page set you just selected.

- 14** Press the **MENU** key. The display returns to Ready.

3.6.3 Alternative Emulation for KPD L Emulation

The auto KPD L [KPD L (AUTO)] emulation enables the printer to automatically change the emulation mode according to the print job received. The emulation mode the printer switches alternatively can be selected using the operator panel. The default alternative emulation is HP PCL 6.

- 1** Press the **MENU** key.
- 2** Press the Δ or ∇ key repeatedly until Emulation > appears.

```
Emulation >
PCL 6
```

- 3** Press the **ENTER** key. A blinking question mark (?) appears.

```
Emulation
?PCL 6
```

- 4** Press the Δ or ∇ key repeatedly until KPD L (AUTO) appears. Press the **ENTER** key.

```
Emulation
?KPD L (AUTO)
```

- 5** Press the \triangleright key. Press the Δ or ∇ key until >Alt. Emulation is displayed. The alternative emulation currently selected also appears — PCL 6 or KC-GL.

- 6** To change the alternative emulation, press the **ENTER** key. A blinking question mark (?) appears.

```
>Alt. Emulation
?PCL 6
```

- 7** Press the Δ or ∇ key until the desired alternative emulation appears.

- 8** Press the **ENTER** key.

- 9** Press the **MENU** key. The display returns to Ready.

3.6.4 Printing KPD L Errors

The printer can print error descriptions when printing error occurs during KPD L emulation. The default is Off — the printer does not print KPD L errors.

- 1** Press the **MENU** key.
- 2** Press the Δ or ∇ key repeatedly until Emulation > appears.

```
Emulation >
PCL 6
```

- 3** Press the **ENTER** key. A blinking question mark (?) appears.

```
Emulation
?PCL 6
```

- 4** Select KPDL or KPDL (AUTO) using the Δ or ∇ key.

```
Emulation
?KPDL
```

- 5** Press the **ENTER** key.

- 6** Press the \triangleright key. Press the Δ or ∇ key until >Print KPDL Errs (errors) appears.

```
>Print KPDL Errs
Off
```

- 7** Press the **ENTER** key. A blinking question mark (?) appears.

- 8** Select On using the Δ or ∇ key. Press the **ENTER** key.

```
>Print KPDL Errs
? Off
```

- 9** Press the **MENU** key. The display returns to Ready.

3.6.5 Default Font

You can select the default font for the current interface. The default font can be one of the internal fonts or a font that is downloaded to the printer memory or stored on memory card or hard disk. The default font of internal fonts is Courier (I000).

In this menu, you can also set the type and pitch for Courier and Letter Gothic; as well as to print a font list.

- 1** Press the **MENU** key.

- 2** Press the Δ or ∇ key repeatedly until Font > appears.

```
Font >
```

- 3** Press the \triangleright key. Press the Δ or ∇ key until >Font Select > appears.

```
>Font Select >
Internal
```

- 4** To select an internal font, make sure that Internal is displayed and press the \triangleright key. The display changes as shown below. If Internal is not displayed, press the **ENTER** key, then press the Δ or ∇ key until it appears.

```
>> I000
```

To select an optional font, press the **ENTER** key while >Font Select > is displayed. Press the Δ or ∇ key repeatedly until Option appears and then press the **ENTER** key. Press the \triangleright key next to display the font selection shown above. You can perform this operation only when optional fonts are installed in the printer.

The letter before the number indicates the location of the font, as shown below:

I	Internal font
SO	Soft (downloaded) font
MO	Fonts in optional memory card
HO	Fonts in RAM disk or optional hard disk (HD-10)

- 5** Press the **ENTER** key. A blinking question mark (?) appears.

```
>>?I000
```

- 6** Press the Δ or ∇ key repeatedly until the desired font number appears. For font numbers of the internal fonts, see [Printing lists of fonts on page 3-36](#).

- 7** When the desired font is displayed, press the **ENTER** key.

- 8** Press the **MENU** key. The display returns to Ready.

Selecting regular or dark Courier/Letter Gothic

Courier or Letter Gothic font thickness can be selected as Regular or Dark. In the procedure below, it is assumed that Courier is selected. The procedure is the same for Letter Gothic.

- 1** Press the **MENU** key.
- 2** Press the Δ or ∇ key repeatedly until `Font >` appears.

```
Font >
```
- 3** Press the \triangleright key. Press the Δ or ∇ key until `>Font Select >` appears.

```
>Font Select >
  Internal
```
- 4** Make sure that `Internal` is displayed and press the \triangleright key.
- 5** Press the Δ or ∇ key repeatedly until `>>Courier` appears. If you are selecting the thickness of the Letter Gothic font, choose `>> Letter Gothic` here instead.

```
>>Courier
  Regular
```
- 6** Press the **ENTER** key. A blinking question mark (?) appears.

```
>>Courier
? Regular
```
- 7** Select Regular or Dark using the Δ or ∇ key.
- 8** Press the **ENTER** key.
- 9** Press the **MENU** key. The display returns to Ready.

Changing the default font size

You can change the size of the default font. If you selected a proportional font, the character size can also be changed.

- 1** Press the **MENU** key.
- 2** Press the Δ or ∇ key repeatedly until `Font >` appears.

```
Font >
```
- 3** Press the \triangleright key. Press the Δ or ∇ key until `>Font Select >` appears.

```
>Font Select >
  Internal
```
- 4** Make sure that `Internal` is displayed and press the \triangleright key.
- 5** Press the Δ or ∇ key repeatedly until `>>Size` appears.

```
>>Size
  012.00 point(s)
```
- 6** Press the **ENTER** key. A blinking cursor (|) appears.

```
>>Size
  012.00| point(s)
```
- 7** Press the Δ or ∇ key to increase or decrease the value at the blinking cursor. The font size can be set between 4 and 999.75 points, in 0.25-point increments. Use the \triangleright or \triangleleft key to move the cursor right and left.
- 8** When the desired size is displayed, press the **ENTER** key.
- 9** Press the **MENU** key. The display returns to Ready.

Character pitch for Courier/Letter Gothic

You can set the character pitch for fixed fonts when the default font is Courier or Letter Gothic.

- 1** Press **MENU** key.
- 2** Press the Δ or ∇ key repeatedly until `Font >` appears.

```
Font >
```
- 3** Press the \triangleright key. Press the Δ or ∇ key until `>Font Select >` appears.

```
>Font Select >
  Internal
```
- 4** Make sure that `Internal` is displayed and press the \triangleright key.
- 5** Press the Δ or ∇ key repeatedly until `>>Pitch` appears.

```
>>Pitch
      10.00 cpi
```
- 6** Press the **ENTER** key. A blinking cursor (`_`) appears.

```
>>Pitch
      10.00_ cpi
```
- 7** Press the Δ or ∇ key to increase or decrease the value at the blinking cursor. The character pitch can be set between 0.44 and 99.99 characters per inch, in 0.01 character-per-inch increments. Use the \triangleright or \triangleleft key to move the cursor right and left.
- 8** When the desired size is displayed, press the **ENTER** key.
- 9** Press the **MENU** key. The display returns to `Ready`.

Setting the character code set

You can change the character code set. Available character code sets vary depending on the current font. (The default character code set is `IBM PC-8`.)

- 1** Press the **MENU** key.
- 2** Press the Δ or ∇ key repeatedly until `Font >` appears.

```
Font >
```
- 3** Press the \triangleright key.
- 4** Press the Δ or ∇ key repeatedly until `>Code Set` appears.

```
>Code Set
  IBM PC-8
```
- 5** Press the **ENTER** key. A blinking question mark (?) appears.

```
>Code Set
?IBM PC-8
```
- 6** Press the Δ or ∇ key until the desired character code set appears.
- 7** Press the **ENTER** key.
- 8** Press the **MENU** key. The display returns to `Ready`.

Printing lists of fonts

To help you decide in selecting a font, you can printout lists of the internal fonts or the optional fonts including downloaded fonts. Samples for font lists are shown in [Figure 3-10 on page 3-37](#).

- 1** Press the **MENU** key.
- 2** Press the Δ or ∇ key repeatedly until `Font >` appears.



3.7 Pagination

In Page Set menus, you can set the number of copies, page orientation, and other settings regarding pagination.

3.7.1 Number of Copies

You can set the number of copies of each page to be printed for the current interface. The number of copies can be set between 1 and 999.

- 1 Press the **MENU** key.
- 2 Press the Δ or ∇ key repeatedly until `Page Set >` appears.

```
Page Set >
```

- 3 Press the \triangleright key.
- 4 Press the Δ or ∇ key repeatedly until `>Copies` appears.

```
>Copies      001
```

- 5 Press the **ENTER** key. A blinking cursor () appears.

```
>Copies      001
```

- 6 Press the Δ or ∇ key to increase or decrease, respectively, the value at the blinking cursor. Use the \triangleright and \triangleleft keys to move the cursor right and left.
- 7 When the desired number of copies is displayed, press the **ENTER** key.
- 8 Press the **MENU** key. The display returns to `Ready`.

3.7.2 Print Orientation

You can select portrait (upright) or landscape (sideways) page orientation.

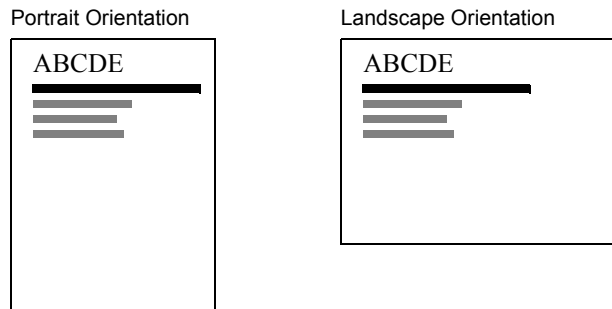

Figure 3-11

- 1 Press the **MENU** key.
- 2 Press the Δ or ∇ key repeatedly until `Page Set >` appears.

```
Page Set >
```

- 3 Press the \triangleright key.
- 4 Press the Δ or ∇ key repeatedly until `>Orientation` appears.

```
>Orientation
Portrait
```

- 5 Press the **ENTER** key. A blinking question mark (?) appears.

```
>Orientation
? Portrait
```

- 6 Select `Portrait` or `Landscape` using the Δ or ∇ key.
- 7 Press the **ENTER** key.
- 8 Press the **MENU** key. The display returns to `Ready`.

3.7.3 Linefeed (LF) Action

This procedure instructs the printer what to do when it receives a linefeed code (0AH).

- LF Only: Linefeed is performed (Default).
- CR and LF: A linefeed and carriage return are performed.
- Ignore LF: The linefeed is ignored.

- 1 Press the **MENU** key.
- 2 Press the Δ or ∇ key repeatedly until Page Set > appears.

```
Page Set >
```

- 3 Press the \triangleright key.
- 4 Press the Δ or ∇ key repeatedly until >LF Action appears.

```
>LF Action
  LF only
```

- 5 Press the **ENTER** key. A blinking question mark (?) appears.

```
>LF Action
? LF only
```

- 6 Press the Δ or ∇ key repeatedly until the desired linefeed action appears.
- 7 When the desired action is displayed, press the **ENTER** key.
- 8 Press the **MENU** key. The display returns to Ready.

3.7.4 Carriage-Return (CR) Action

This procedure instructs the printer what to do when it receives a carriage-return code (0DH).

- CR Only: A carriage-return is performed (Default).
- CR and LF: A linefeed and carriage return are performed.
- Ignore CR: The carriage-return is ignored.

- 1 Press the **MENU** key.
- 2 Press the Δ or ∇ key repeatedly until Page Set > appears.

```
Page Set >
```

- 3 Press the \triangleright key.
- 4 Press the Δ or ∇ key repeatedly until >CR Action appears.

```
>CR Action
  CR only
```

- 5 Press the **ENTER** key. A blinking question mark (?) appears.

```
>CR Action
? CR only
```

- 6 Press the Δ or ∇ key repeatedly until the desired carriage-return action appears.
- 7 When the desired action is displayed, press the **ENTER** key.
- 8 Press the **MENU** key. The display returns to Ready.

3.8 Setting Print Quality

The printer features the Print Quality menu which lets you select:

- Tone mode (Normal and Fine)
- Gloss mode (Low and High)

3.8.1 Tone Mode

The Tone Mode selects the way the printer handles a pixel for representing the color and halftoning for each pixel — Normal or Fine. The Fine tone mode uses four-bit smooth halftone for photographs, image, etc.; and the Normal tone mode uses a two-bit halftone for text, solid objects, etc. Either of these tone modes consistently affects all objects on a page.

The Fine tone mode provides the print quality better than Normal, but the printing speed is slower and more memory is required. To enable the printing in Fine tone mode (4 bpp) on A3 with duplex printing, the minimum printer memory requirement is approximately 160 MB.



The amount of memory actually required may vary depending on the data to print.

Note

The default tone mode is Normal. To confirm and change the tone mode, proceed as follows:

- 1 Press the **MENU** key.
- 2 Press the Δ or ∇ key repeatedly until `Print Quality >` appears.

```
Print Quality >
```

- 3 Press the \triangleright key.
- 4 Press the Δ or ∇ key repeatedly until `>Tone` appears.

```
>Tone
Normal
```

- 5 To change the toner mode, press the **ENTER** key. A blinking question mark (?) appears.

```
>Tone
? Normal
```

- 6 Press the Δ or ∇ key to change to Fine.
- 7 Press the **ENTER** key to finalize the tone mode.
- 8 Press the **MENU** key. The display returns to Ready.

3.8.2 Gloss Mode

The gloss mode, when set to High, increases the effect of glossiness in printing by reducing the printing speed by half. The gloss mode is not available when Transparency is selected as the paper type setting.



Depending on the paper used, printing in gloss mode may cause wrinkle in paper. To reduce wrinkle, try using thicker paper.

Note

The default gloss mode is Low. To confirm or change the gloss mode, proceed as follows:

- 1 Press the **MENU** key.
- 2 Press the Δ or ∇ key repeatedly until `Print Quality >` appears.

```
Print Quality >
```

- 3 Press the \triangleright key.
- 4 Press the Δ or ∇ key repeatedly until `>Gloss Mode` appears.

```
>Gloss Mode
Low
```

- 5** To change the gloss mode, press the **ENTER** key. A blinking question mark (?) appears.

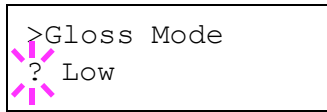

```
>Gloss Mode
? Low
```

- 6** Press the \triangle or ∇ key to change from Low to High.
- 7** Press the **ENTER** key to finalize the selection.
- 8** Press the **MENU** key. The display returns to Ready.

3.9 Operating the Storage Device

The printer supports three types of storage device: memory card, option hard disk (HD-10), and RAM disk. The memory card and option hard disk are installed into the dedicated slots of the printer. The RAM disk is an allocated part of the printer's memory. If the optional hard disk is installed in the printer, the e-MPS function will be available. For details, see [e-MPS on page 3-20](#).

The basic operations of each storage device are the same. This section mainly explains the operation of the memory card.

3.9.1 Using the Memory Card

The printer is equipped with a slot for a memory card. By inserting a memory card into the printer, the following operations become available.

- Formatting Memory Card
- Reading Font Data
- Reading Data
- Writing Data
- Deleting Data
- Printing a List of Data Names

For details about the handling of the memory card, see [A.3.1 Memory Card on page A-5](#).

Formatting a memory card

A new memory card must be formatted before it can be used in the printer. Formatting allows data to be written to the memory card.



Note

- **Formatting will destroy any existing data on a storage device including a used memory card.**
- **Formatting of the memory card must be executed from the printer.**

To format a memory card, proceed as follows. When a new memory card is inserted in the printer's slot, `Format error Memory card` will appear on the message display.

- 1 Press the **MENU** key.
- 2 Press the Δ or ∇ key repeatedly until `Memory Card >` appears.

```
Memory Card >
```

- 3 Press the \triangleright key.
- 4 Press the Δ or ∇ key repeatedly until `>Format` appears.

```
>Format
```

- 5 Press the **ENTER** key. A question mark (?) appears.

```
>Format ?
```

- 6 Press the **ENTER** key. `Processing` appears and formatting of the memory card starts.

Reading font data

In case of a memory card if a memory with the font data card is already inserted into the slot when the printer is turned on, the fonts are automatically read into the printer. To read fonts into the printer from a memory card, proceed as follows.

- 1 Press the **MENU** key.
- 2 Press the Δ or ∇ key repeatedly until `Memory Card >` appears.

```
Memory Card >
```

- 3 Press the \triangleright key.
- 4 Press the Δ or ∇ key repeatedly until `>Read Fonts` appears.

```
>Read Fonts
```

- 5 Press the **ENTER** key. A question mark (?) appears.

```
>Read Fonts ?
```

- 6** Press the **ENTER** key. *Processing* appears and the reading of data from the memory card starts. When completed, *Processing* disappears.

```
>Read Fonts
Processing
```

- 7** Press the **MENU** key. The display returns to *Ready*.

Reading data

You can print out the data in the memory card. To read the data saved on the memory card and print it out, proceed as follows.

- 1** Press the **MENU** key.
- 2** Press the Δ or ∇ key repeatedly until *Memory Card >* appears.

```
Memory Card >
```

- 3** Press the \triangleright key.
- 4** Press the Δ or ∇ key repeatedly until *>Read Data* appears (*Report*, in this example).

```
>Read Data
Report
```

- 5** Press the **ENTER** key. A blinking question mark (?) appears before the data name.

```
>Read Data
?Report
```

- 6** Press the Δ or ∇ key to display the desired data name.
- 7** Press the **ENTER** key. *Processing* appears and the reading of data from the memory card starts.

Writing data

Data can be written to a memory card until no space is left for storing. When writing to a memory card, a name is assigned to the file automatically. You can use the procedure explained in the section *Printing a list of data names (Partitions) on page 3-45* to print a list of data names for confirmation.

To write data to a memory card, proceed as follows.

The memory card must be properly formatted by the printer. If the memory card inserted in the memory card slot is not formatted, the *>Format* menu will automatically appear on the message display. Format the memory card according to instructions provided in *Formatting a memory card on page 3-42*.

- 1** Press the **MENU** key.
- 2** Press the Δ or ∇ key repeatedly until *Memory Card >* appears.

```
Memory Card >
```

- 3** Press the \triangleright key.
- 4** Press the Δ or ∇ key repeatedly until *>Write Data* appears.

```
>Write Data
```

- 5** Press the **ENTER** key. A question mark (?) appears.

```
>Write Data ?
```

- 6** Press the **ENTER** key. *Processing* appears, then *Waiting*.
- 7** In this state, send the file from the computer to the printer.

As the printer receives data, the message display changes to *Processing*, then when the end of the data is received, the message display changes to *Waiting*.

- 8 Check that the message display has changed to Waiting, then press the **GO** key. This writes the file to the memory card and instructs the printer to automatically print out a memory card write information page as shown below.

The file is written onto the memory card given a destination name (also referred to as a partition name) which the printer automatically assigns one after another as follows: DataS001 (first data), DataS002 (second data), DataS003 (third data)...

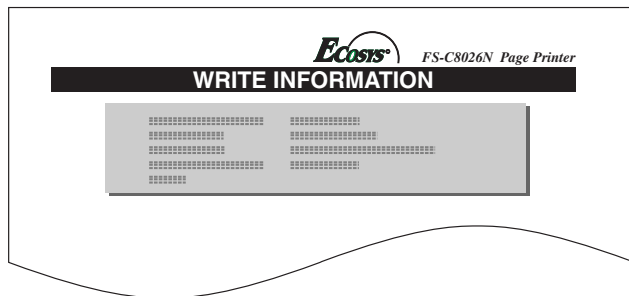

Figure 3-12

- Partition Type:** Type of data written (currently only type 2 is supported).
- Partition Name:** The destination name of data written to the card.
- Write Partition Length:** The size of the written data on the memory card.
- Others:** Error information.

When the memory card write information page is printed, the display returns to Ready.

- 9 Repeat above steps until you have transferred all data (files) that you want to write to the memory card. Each time you finish writing data, a memory card write information page is printed from the printer showing the information, but pertaining only to the data just written. To see all data contained in the memory card at once, print a list of data names as explained. See *Printing a list of data names (Partitions) on page 3-45*.

Deleting data

It is possible to use the printer to delete data from a memory card one by one.

To delete data from a memory card, proceed as follows. Check that the memory card contains data. Otherwise, the >Delete Data menu will not appear on the message display.

- 1 Press the **MENU** key.
- 2 Press the Δ or ∇ key repeatedly until Memory Card > appears.

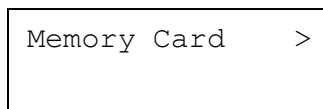

- 3 Press the \triangleright key.
- 4 Press the Δ or ∇ key repeatedly until >Delete Data appears. The data name also appears (Report, in this example).

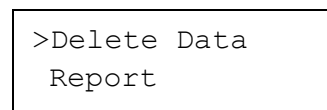

- 5 Press the **ENTER** key. A blinking question mark (?) appears before the data name.

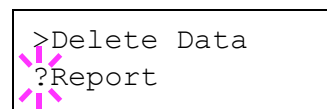

- 6 Press the Δ or ∇ key to display the desired data name.
- 7 Press the **ENTER** key. Processing appears and the data is deleted from the memory card. The display returns to Ready.

When the formatting is successfully completed, the printer automatically prints out a format information page (FORMAT INFORMATION), which allows you to check the memory card for proper formatting.

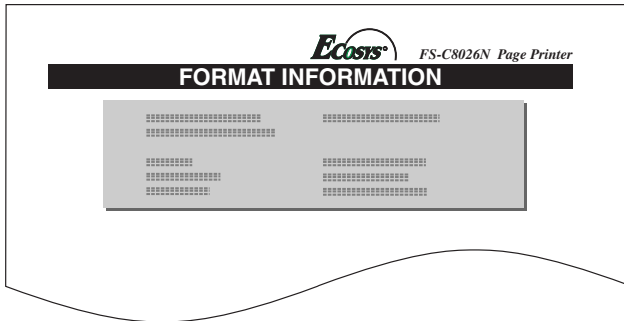

Figure 3-13

Format information page includes the following items:

- Capacity:** The total size of the memory card.
- Used Space:** The size the printer uses for its system.
- Free Space:** The size remaining in the memory card for storing data.

When the memory card format information is printed, the display returns to Ready.

Printing a list of data names (Partitions)

The printer prints a list of all data names (referred to as partitions) stored in a memory card for reference. (Printing a list is also available for a font card.)

To print a list of data names for the memory card, proceed as follows.

- 1** Press the **MENU** key.
- 2** Press the Δ or ∇ key repeatedly until Memory Card > appears.

```
Memory Card >
```

- 3** Press the \triangleright key.
- 4** Press the Δ or ∇ key repeatedly until >List of Partitions appears.

```
>List of
Partitions
```

- 5** Press the **ENTER** key. A question mark (?) appears.

```
>List of
Partitions ?
```

- 6** Press the **ENTER** key. Processing appears and the printing of the list starts.

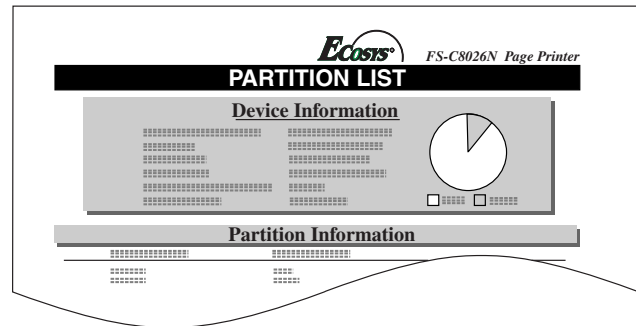

Figure 3-14

The printout (example above) includes the following information:

- Device Name/Number:** MEMORY CARD/A is indicated for the memory card.
- Capacity:** The total capacity of the memory card in bytes.
- Used Space:** The total size of the data stored in the memory card in bytes.
- Free Space:** The size of the capacity remaining in the memory card for storing further data, including the amount of memory that the printer uses for its system.
- Partition Name:** The name of the written data assigned automatically by the printer.
- Partition Size:** The size of the written data in bytes.
- Partition Type:** The type of the written data i.e., whether it is host data (Data) or font data (Font).

When the list of file names (partition list) for the memory card is printed, the display returns to Ready.

3.9.2 Using the Option Hard Disk (HD-10)

Installing the option hard disk into the printer allows you to perform the following operations on the hard disk.

- Reading data
- Writing data
- Deleting data
- Formatting hard disk
- Printing a list of data names (partitions)

When an option hard disk is inserted into the printer for the first time, it must be formatted before use. If the option hard disk is not formatted, the >Format menu will automatically appear on the message display.

The operations of the option hard disk are the same as those of the memory card. See the relevant sections in [Section 3.9.1 Using the Memory Card on page 3-42](#).

When data is written to the hard disk, the name automatically given to the corresponding file will be DataH001 (for the 1st file), DataH002 (for the 2nd file), DataH003 (for the 3rd file), etc.

3.9.3 Using the RAM Disk

The RAM disk is a memory space shared within the printer memory that can temporarily store print jobs. The RAM disk can be used only for electronic sorting. The stored print job can then be used to print multiple copies of the job reducing the total amount of time required to print the whole job. It acts similar to the hard disk except that the data is effective only during the printer is powered up. By default, the RAM disk is not activated (Off).

To use the RAM disk, activate and enter the desired size of the RAM disk in the manner described below. The maximum RAM disk size can be calculated as follows:

Maximum RAM disk size = Total printer memory - 36 MB

For example, if the total memory installed in your printer is 256 MB, you can set 224 MB of RAM disk. If you attempt to set the RAM disk size beyond this restriction, the printer automatically round it down so that the size is always 36 MB less than the total printer memory. Once the RAM disk size is set, the printer must be reset.

To activate RAM disk in the printer's memory, first you must set the RAM disk mode to On and set the desired data size for the RAM disk as described in the following section. This allows you to perform the following operations on the RAM disk.

- Reading data
- Writing data

- Deleting data
- Printing a list of data names (partitions)

The operations of the RAM disk are the same as those of the memory card. See the relevant sections in [Section 3.9.1 Using the Memory Card on page 3-42](#). When data is written to the RAM disk, the name automatically given to the corresponding file will be DataH001 (for the 1st file), DataH002 (for the 2nd file), DataH003 (for the 3rd file), etc.



Note

- **The RAM disk can not be used when an option hard disk is installed.**
- **The RAM disk stores data only temporarily. When the printer is reset or turned off, the stored data will be erased.**
- **The RAM disk is allocated within the printer's memory available to users. If the size of the RAM disk is set too large, the printing speed may decrease or the memory may become insufficient, causing a printing error.**

To confirm the RAM disk size or activate the RAM disk, proceed as follows:

Setting the RAM disk size

- 1 Press the **MENU** key.
- 2 Press the Δ or ∇ key repeatedly until RAM Disk Mode appears.



- 3 Press the **ENTER** key. A blinking question mark (?) appears. Press the Δ or ∇ key to select On. Press the **ENTER** key.



- 4 Press the \triangleright key. Press the Δ or ∇ key repeatedly until >RAM Disk Size appears. The data size also appears.



- 5** Press the **ENTER** key. A blinking cursor () appears. Press the Δ or ∇ key to display the desired size. Definable RAM disk size is 0001 to 1024.

```
>RAM Disk Size
  0119 MByte
```

This range varies depending on the total memory size of the printer.

- 6** When the desired RAM disk size is displayed, press the **ENTER** key.
- 7** Press the **MENU** key. The display returns to Ready. Then, turn off the printer and on again. The selected RAM disk size is activated after the printer is restarted.

3.10 Paper Handling

This section explains how to change mode for the MP (multi-purpose) tray, the paper size and type for each paper source, and how to select the paper source and paper destinations.

3.10.1 MP Tray Mode

The MP tray can be used in either of two modes — *Cassette* or *First*. The MP tray feeds paper differently depending on the mode:

- **Cassette Mode (default)**
The MP tray acts in the same manner as the paper feed cassette. The printer can feed paper the MP tray in the similar manner as you would do on the printer driver to feed paper from the paper feed cassette. The cassette mode provides a faster printing speed than the first mode. To use the MP tray in cassette mode, select the paper size of the MP tray. Refer to [3.10.2 Setting MP Tray Paper Size](#) on page 3-48.
- **First Mode**
The MP tray automatically feeds paper placed on the MP tray overriding another paper source that is selected on the printer driver. After all paper sheets in the MP tray have been used up, paper will be fed from the paper source originally selected. This mode is convenient to feed paper of special size or type without reloading the current paper source. However, the MP tray must be kept empty if you desire to feed paper from the intended paper source.

To switch the MP tray mode, for example, to *First* mode, proceed as follows:

- 1 Press the **MENU** key.
- 2 Press the Δ or ∇ key repeatedly until *Paper Handling >* appears.
- 3 Press the \triangleright key.
- 4 Press the Δ or ∇ key repeatedly until *>MP Tray Mode* appears.

```
Paper Handling >
```

```
>MP Tray Mode
Cassette
```

- 5 Press the **ENTER** key. A blinking question mark (?) appears.

```
>MP Tray Mode
? Cassette
```

- 6 Press the Δ or ∇ key to change *Cassette* to *First*.
- 7 Press the **ENTER** key. The MP tray mode is changed.
- 8 To exit the menu selection, press the **MENU** key.

3.10.2 Setting MP Tray Paper Size

When you use the MP tray in cassette mode, you should set the MP tray size to the paper size that is used to format the job to print. If the sizes do not match, printing will be done on the wrong size paper. The default setting is *Letter* size for the U.S. and Canada and *A4* for other countries.

For more information about the paper sizes that you can feed from the MP tray, see [Chapter 2 Handling Paper](#).

- 1 Press the **MENU** key.
- 2 Press the Δ or ∇ key repeatedly until *Paper Handling >* appears.

```
Paper Handling >
```

- 3 Press the \triangleright key.
- 4 Press the Δ or ∇ key repeatedly until *>MP Tray Size* appears. In this example, the current MP tray paper size is *A4*.

```
>MP Tray Size
A4
```

- 5 To change the paper size, press the **ENTER** key. A blinking question mark (?) appears.

```
>MP Tray Size
? A4
```

- 6** Press the Δ or ∇ key to display the desired paper size. The message display toggles through the following paper sizes:

Business
 Comm.#9
 Comm.#6 3/4
 DL
 C5
 A6
 B6
 A5
 B5
 B5-R
 ISO B5
 A4-R
 A4
 A4 Executive
 Letter-R
 Letter
 Legal
 Ledger
 A3
 B4
 Custom
 C4
 Hagaki
 OufukuHagaki
 Oficio II
 Statement
 Folio
 Youkei 2
 Youkei 4
 8K
 16K
 12x18

- 7** When the desired paper size is displayed, press the **ENTER** key. The paper size is set for the MP tray.

- 8** To exit the menu selection, press the **MENU** key.

3.10.3 Setting the MP Tray Paper Type

By setting a paper type (plain, recycled, etc.) to the MP tray, you can feed the paper on the MP tray according to the paper type you command on the printer driver. The default setting is plain paper.

For more information about paper types that can be fed from the MP tray, see [Chapter 2 Handling Paper](#).

- 1** Press the **MENU** key.
- 2** Press the Δ or ∇ key repeatedly until Paper Handling > appears.



Paper Handling >

- 3** Press the \triangleright key.
- 4** Press the Δ or ∇ key repeatedly until >MP Tray Type appears.

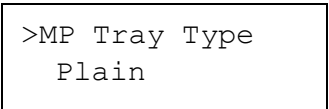

>MP Tray Type
Plain

- 5** To change paper type, press the **ENTER** key. A blinking question mark (?) appears.

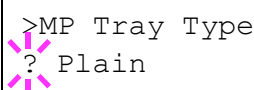

>MP Tray Type
? Plain

- 6** Press the Δ or ∇ key to display the desired paper type. The message display toggles through the following paper types:

Plain
 Trasparency
 Preprinted
 Labels
 Bond
 Recycled
 Vellum
 Rough
 Letterhead
 Color
 Envelope
 Cardstock
 Coated
 Thick
 High quality
 Custom 1 (to 8)

- 7** When the desired paper type is displayed, press the **ENTER** key. The paper type is set to the MP tray.
- 8** To exit the menu selection, press the **MENU** key.

3.10.4 Setting the Cassette Paper Type

After you assign a paper type to each of the paper cassettes, the printer will automatically select the correct cassette in accordance with the paper type you specify on your computer for printing. The default setting for all paper cassettes is plain paper.

If you have an optional paper feeder installed on your printer, you can also use this procedure to specify the paper type of the paper feeder paper cassette.

For more information about paper types, see *Chapter 2 Handling Paper*.

- 1** Press the **MENU** key.
- 2** Press the Δ or ∇ key repeatedly until Paper Handling > appears.

```
Paper Handling >
```

- 3** Press the \triangleright key.
- 4** Press the Δ or ∇ key repeatedly until >Cassette # Type appears. (Where # here refers to the cassette number.)

```
>Cassette 1 Type
Plain
```



When the optional Duplex Unit (DU-640) is installed, the duplex drawer takes up the space of topmost cassette. Because of this, cassette numbering starts from 2.

- 5** To change paper type, press the **ENTER** key. A blinking question mark (?) appears.

```
>Cassette 1 Type
? Plain
```

- 6** Press the Δ or ∇ key to display the desired paper type. The message display toggles through the following paper types:

```
Plain
Preprinted
Bond
Recycled
Vellum
Letterhead
Color
Prepunched
High quality
Custom 1 (to 8)
```

- 7** When the desired paper type is displayed, press the **ENTER** key.
- 8** To exit the menu selection, press the **MENU** key.

3.10.5 Selecting the Paper Feed Source

You can select the paper source using the operator panel, from which the printer feeds paper as the default. If an optional paper feeder(s) is installed, it is also available for the default paper source.

- 1** Press the **MENU** key.
- 2** Press the Δ or ∇ key repeatedly until Paper Handling > appears.
- 3** Press the \triangleright key.
- 4** Press the Δ or ∇ key repeatedly until >Feed Select appears.

```
Paper Handling >
```

```
>Feed Select
Cassette 1
```

- 5** To change the current paper feed source, press the **ENTER** key. A blinking question mark (?) appears.

```
>Feed Select
? Cassette 1
```

- 6** Press the Δ or ∇ key to display the desired paper feed source. The message display toggles through the following paper feed sources, depending on the installed optional paper feeders (from the top most paper cassette to the bottom paper cassette):

MP tray
 Cassette 1
 Cassette 2
 Cassette 3
 Cassette 4
 Cassette 5



Note

When the optional Duplex Unit (DU-640) is installed, the duplex drawer takes up the space of topmost cassette. Because of this, cassette numbering starts from 2.

- 7** When the desired paper source displayed, press the **ENTER** key.
- 8** To exit the menu selection, press the **MENU** key.

3.10.6 Duplex Printing

An optional duplex unit (DU-640) makes it possible to print on both sides of the paper. For details about the duplex unit, see [Appendix A Options](#).

Duplex printing can be performed using the following types of paper:

Plain
 Preprinted
 Bond
 Recycled
 Rough
 Letterhead
 Color
 Prepunched
 High quality
 Custom

For more information about paper types, see [Paper sizes on page 2-4](#).

Binding modes

Binding refers to the manner in which printed pages of paper are joined together (by gluing, stitching, etc.) in book form. The two possible types of binding are: long-edge binding, in which pages are joined together along their long edge; and short-edge binding, in which they are joined together along their short edge. In selecting a binding type, you must also consider the orientation of the printed page. You can use long-edge or short-edge binding with either landscape or portrait printing.

Depending on the binding type and print orientation, the duplexer provides four types of binding. These are: (1) portrait, long-edge, (2) portrait, short edge, (3) landscape, long-edge, and (4) landscape, short-edge. The figure below shows these binding methods.

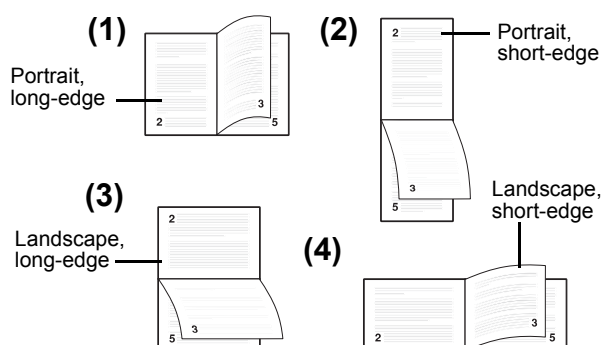

Figure 3-15

To select duplex printing and binding from the operator panel, use the following procedure:

- 1** Press the **MENU** key.
- 2** Press the Δ or ∇ key repeatedly until Paper Handling > appears.

Paper Handling >

- 3** Press the \triangleright key.
- 4** Press the Δ or ∇ key repeatedly until >Duplex Mode appears.

>Duplex Mode
 None

- 5** To activate duplex printing, press the **ENTER** key. A blinking question mark (?) appears.

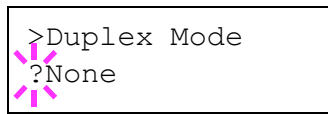

- 6** Press the Δ or ∇ key to display the desired binding mode. The message display toggles through the following:

```

None (default)
Long edge bind
Short edge bind
    
```

- 7** When the desired binding mode is displayed, press the **ENTER** key. The binding mode is set.

- 8** To exit the menu selection, press the **MENU** key.

Note on Duplex Printing from the MP Tray

Duplex printing can be also performed from the multi-purpose (MP) tray. When the MP tray is set to first mode (*First*), the paper size and paper type will be the same as those of the paper cassette currently set at the paper feed source.

3.10.7 Adjusting the Stitch Positions

When installing the option document finisher DF-610 and booklet folder BF-1, adjust the stitch positions using the following procedures. In the default settings, the stitch position is set in the center of the paper. Depending on the paper, a certain amount of deviation will occur. In this case, also use this menu to adjust the stitch position. The adjustment can be done by moving the stitch position adjustment gear in the document finisher.

For example, select the range from -10 to +10 (1 = approximately 0.6 mm) to move the stitch position approximately 6 mm as shown in the following figure. The default setting is 000 (center of the paper.)

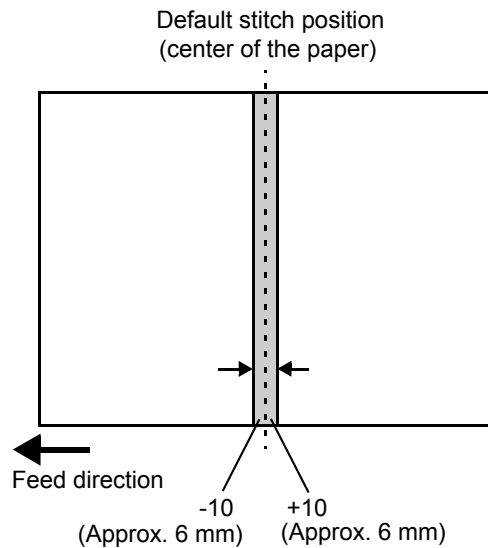

- 1** Press the **MENU** key.
- 2** Press the Δ or ∇ key repeatedly until Paper Handling > appears.

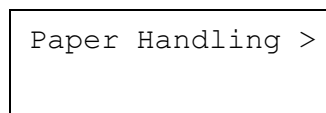

- 3** Press the \triangleright key. >Stitch Adjust > appears.

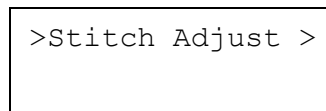

- 4** Press the \triangleright key. >>A4/Letter appears.

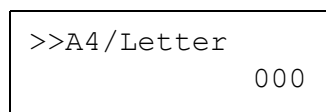

- 5** Press the Δ or ∇ key to select A4/Letter, B4 or A3/Ledger.

- 6** When the desired paper size is displayed, press the **ENTER** key. A blinking cursor () appears under the value.

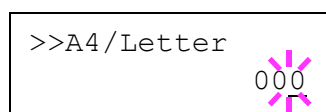

- 7** Press the Δ or ∇ key to increase or decrease, respectively, the value at the blinking cursor. Use the \triangleright and \triangleleft keys to move the cursor right and left.

Definable value: -010 to 010

- 8** When the desired value is displayed, press the **ENTER** key.
- 9** Press the **MENU** key. The message display returns to Ready.

3.10.8 Overriding Difference between A4 and Letter

When the `Override A4/LT` is turned on using the operator panel, the printer ignores the difference between A4 and Letter paper sizes. The printer prints on A4 size paper when a job formatted in letter size is sent and no letter size paper is loaded in the printer and vice versa.



Some part in the original job, which does not fit in the overridden paper may be lost.

Note

By default, this feature is off. To confirm and turn on the `Override A4/LT`, proceed as follows:

- 1** Press the **MENU** key.
- 2** Press the Δ or ∇ key repeatedly until `Paper Handling >` appears.

```
Paper Handling >
```

- 3** Press the \triangleright key.
- 4** Press the Δ or ∇ key repeatedly until `>Override A4/LT` appears.

```
>Override A4/LT
Off
```

- 5** To change overriding mode, press the **ENTER** key. A blinking question mark (?) appears.

```
>Override A4/LT
? Off
```

- 6** Press the Δ or ∇ key to change `Off` to `On`.
- 7** Press the **ENTER** key. The overriding mode is set.
- 8** To exit the menu selection, press the **MENU** key.

3.10.9 Creating Custom Paper Types

You can use the Type Adjust menu to create your own custom paper types on the printer. After you create a custom paper type, you can assign it to a particular paper source for automatic selection by the printer.

You can configure up to eight custom paper types. Creating a custom paper type on the operator panel is a 3-step task:

STEP 1: Select one of eight custom paper positions (Custom 1 through 8).

STEP 2: Specify the weight of the paper.

STEP 3: Enable or disable duplex printing for the paper (if your printer has the optional duplex unit installed).

See [3.10.9 Creating Custom Paper Types on page 3-53](#) for information about how to return custom paper settings to their initial defaults.

Step 1. Selecting the custom type position

- 1** Press the **MENU** key.
- 2** Press the Δ or ∇ key repeatedly until `Paper Handling >` appears.

```
Paper Handling >
```

- 3** Press the \triangleright key.
- 4** Press the Δ or ∇ key repeatedly until `>Type Adjust >` appears.

```
>Type Adjust >
Custom 1
```

- 5** Press the **ENTER** key. A blinking question mark (?) appears.

```
>Type Adjust
? Custom 1
```

- 6 Press the Δ or ∇ key to scroll to the other custom position.

Custom 1
Custom 2
Custom 3
Custom 4
Custom 5
Custom 6
Custom 7
Custom 8

- 7 When the paper type to be customized is displayed, press the **ENTER** key. Proceed to the next procedure.

Step 2. Selecting the paper weight

- 1 Complete **Step 1.** above.
- 2 Press the \triangleright key.
- 3 Press the Δ or ∇ key repeatedly until \gg Paper Weight appears.

```
>>Paper Weight  
Normal
```

- 4 Press the **ENTER** key. A blinking question mark (?) appears.

```
>>Paper Weight  
? Normal
```

- 5 Press the Δ or ∇ key to display the desired paper thickness for the paper:

Light
Normal 1 (2, 3)
Heavy 1 (2, 3)
Extra Heavy

- 6 When the desired paper thickness is displayed, press the **ENTER** key. Proceed to the next procedure.

Step 3. Enabling or disabling duplex printing for custom paper type

This step disables to duplex print when the custom size is selected for the paper type in a print job.

By default, duplex printing is enabled for custom paper types. To confirm and change this, proceed as follows:

- 1 Complete **Step 3.** above.
- 2 Press the \triangleright key.
- 3 Press the Δ or ∇ key repeatedly until \gg Duplex Path appears.

```
>>Duplex Path  
Enable
```

- 4 To change duplex printing, press the **ENTER** key. A blinking question mark (?) appears.

```
>>Duplex Path  
? Enable
```

- 5 Press the Δ or ∇ key to change from Enable to Disable.
- 6 Press the **ENTER** key. The duplex printing capability is changed.
- 7 To exit the menu selection, press the **MENU** key.

3.10.10 Resetting the Custom Paper Type

If you want to reset all custom paper type settings (1 to 8) to the factory default, proceed as follows:

- 1 Press the **MENU** key.
- 2 Press the Δ or ∇ key repeatedly until Paper Handling > appears.

```
Paper Handling >
```

- 3 Press the \triangleright key.

- 4** Press the Δ or ∇ key repeatedly until `>Reset Type Adjust` appears.

```
>Reset Type
Adjust
```

- 5** To reset all custom paper types, press the **ENTER** key. A question mark (?) appears.

```
>Reset Type
Adjust ?
```

- 6** Press the **ENTER** key. All customized paper types, including weight and duplex printing capability, will be reset to the default. The display returns to `Ready`.

3.10.11 Selecting the Output Stack

The Stack Select menu on the operator panel allows you to select either the top (face-down) tray or the face-up tray for the output stack. If the optional document finisher is installed, it can also be selected as an output stack.

- 1** Press the **MENU** key.
- 2** Press the Δ or ∇ key repeatedly until `Paper Handling >` appears.

```
Paper Handling >
```

- 3** Press the \triangleright key.
- 4** Press the Δ or ∇ key repeatedly until `>Stack Select` appears.

```
>Stack Select
Top tray F-down
```

- 5** To change the output stack, press the **ENTER** key. A blinking question mark (?) appears.

```
>Stack Select
? Top tray F-down
```

- 6** Press the Δ or ∇ key to toggle through the following output stacks:

```
Top tray F-down
```

The output stacks change to include the following when an optional document finisher (DF-600/610) is installed:

```
Left tray F-up
Tray # F-up
Tray # F-down
```

- 7** When the desired output stack is displayed, press the **ENTER** key.
- 8** To exit the menu selection, press the **MENU** key.

3.11 Selecting Monochrome or Color Printing

You can use the Color Mode menu on the operator panel to select the Monochrome or Color printing mode. By default, the printer is set to print in color mode. To change it to monochrome mode, proceed as follows:

- 1** Press the **MENU** key.
- 2** Press the Δ or ∇ key repeatedly until `Color Mode` appears.

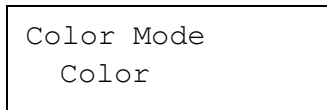

```
Color Mode
Color
```

- 3** To change color mode, press the **ENTER** key. A blinking question mark (?) appears.

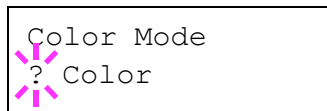

```
Color Mode
? Color
```

- 4** Press the Δ or ∇ key to change color mode — `Color` or `Monochrome`.
- 5** When the desired color mode is displayed, press the **ENTER** key. Color mode is changed.
- 6** To exit the menu selection, press the **MENU** key.

3.12 Reading Life Counters

You can display the total number of pages printed by your printer whenever it is necessary. The total number of printed pages can also be checked on the status page. See [Section 3.3.2 Printing a Status Page on page 3-17](#). For proper maintenance scheduling, you need to reset the toner counter using this menu each time a new toner container is installed.

3.12.1 Displaying the Total Printed Pages

This procedure displays the total number of printed pages. You cannot change the displayed value.

- 1** Press the **MENU** key.
- 2** Press the Δ or ∇ key repeatedly until `Life Counters >` appears.

```
Life Counters >
```

- 3** Press the \triangleright key.
- 4** Press the Δ or ∇ key repeatedly until `>Total Print` appears and the latest total print count is shown.

```
>Total Print
      0123456
```

- 5** To exit the menu selection, press the **MENU** key.

3.12.2 Resetting the Toner Counter

The toner containers must be replaced when the printer displays the `[Low toner]` or `[Replace toner]` message, each of which indicates which color toner is running low.

The `[Low toner]` message is an early warning that tells you toner is running out. If you continue using the printer the printer will stop printing soon thereafter, and display the `[Replace toner]` message. If you replace the toner container before the `[Replace toner]` message appears, you need to manually reset the toner counter as explained below.

Note that if you reset the toner counter without replacing the toner container, subsequent toner warning messages will not appear at the correct times.

- 1** Replace the toner container according to the message given on the message display. To replace the toner containers, see [5.1 Toner Container Replacement on page 5-2](#).
- 2** Press the **MENU** key.
- 3** Press the Δ or ∇ key repeatedly until `Life Counters >` appears.

```
Life Counters >
```

- 4** Press the \triangleright key.
- 5** Press the Δ or ∇ key repeatedly until the message display shows the toner container of the color you replaced — `[C]yan`, `[M]agenta`, `[Y]ellow`, or `blac[K]`. For example, to reset the Cyan toner counter, display `>New Toner [C] Installed`.
- 6** Press the **ENTER** key. A question mark (?) appears.

```
>New Toner [C]
  Installed ?
```

- 7** Press the **ENTER** key. The toner counter is reset.
- 8** To exit the menu selection, press the **MENU** key.

3.13 Other Modes

The following modes can be accessed in the **Others** submenu:

- Message Language
- Automatic Form Feed Timeout Setting
- Sleep Timer Setting
- Received Data Dumping
- Printer Resetting
- Resource Protection
- Alarm (Buzzer) Setting
- Auto Continue Setting
- Duplex Printing Error Detection Setting
- Staple Error Detection Setting
- Punch Error Detection Setting
- Color/Monochrome Print Setting
- Service Menu (for service personnel)
- Color Calibration
- Using High Density Mode

3.13.1 Selecting the Message Language

You can select the language of the messages on the message display by following the procedure given below. You can optionally download messages in other languages. Contact your Kyocera Mita dealer for information.

- 1** Press the **MENU** key.
- 2** Press the Δ or ∇ key repeatedly until **Others** > appears.

Others >
- 3** Press the \triangleright key.
- 4** Press the Δ or ∇ key repeatedly until >MSG Language appears. The default message language is English.

>MSG Language
English
- 5** To change the language, press the **ENTER** key. A blinking question mark (?) appears.

>MSG Language
? English

- 6** Press the Δ or ∇ key. The display cycles through the available selection in the following order:

English
Francais
Deutsch
Italiano
Nederlands
Español
Português

- 7** Press the **ENTER** key.
- 8** Press the **MENU** key. The display returns to Ready.

3.13.2 Automatic Form Feed Timeout Setting

If the printer receives no data for a certain period, it will time out and release the current interface. It prints whatever data it has in its buffer and feeds out the page. The default form feed timeout time is 0 seconds. The printer does not timeout with the value set to 0. You can adjust the time-out time as follows:

- 1** Press the **MENU** key.
- 2** Press the Δ or ∇ key repeatedly until **Others** > appears.

Others >
- 3** Press the \triangleright key.
- 4** Press the Δ or ∇ key repeatedly until >Form Feed Time Out appears.

>Form Feed
Time Out 000sec.
- 5** To change the timeout time, press the **ENTER** key. A blinking cursor (|) appears.

>Form Feed
Time Out 000|sec.

- 6 Press the Δ or ∇ key to increase or decrease the value at the blinking cursor and set the desired time. The timeout time can be between 0 and 495 seconds, in 5-second increments. Use the \triangleright and \triangleleft keys to move the cursor right and left.
- 7 When the desired timeout time is displayed, press the **ENTER** key.
- 8 To exit the menu selection, press the **MENU** key.

3.13.3 Setting the Sleep Timer

The printer has a sleep timer that is used to conserve power when the printer is not printing, processing, or receiving data. You can turn off or on the sleep timer function using the following procedure.

- 1 Press the **MENU** key.
- 2 Press the Δ or ∇ key repeatedly until `Others >` appears.

```
Others >
```

- 3 Press the \triangleright key.
- 4 Press the Δ or ∇ key repeatedly until `>Sleep Timer >` appears.

```
>Sleep Timer >
      030 min.
```

- 5 Press the \triangleright key and display `>>Sleep Mode`.

```
>>Sleep Mode
      On
```

- 6 To turn off the sleep timer, press the **ENTER** key. A blinking question mark (?) appears.

```
>>Sleep Mode
? On
```

- 7 Press the Δ or ∇ key to change `On` to `Off`.

```
>>Sleep Mode
? Off
```

- 8 Press the **ENTER** key. The sleep timer is turned off.
- 9 To exit the menu selection, press the **MENU** key.

Sleep timer timeout

You can adjust the timer timeout time, the length of time the printer waits before entering sleeping mode in the absence of data. The default sleep timer timeout time is 30 minutes.

The printer reverts to normal operation mode when the printer receives a print job, the operator panel is operated, or one of the exterior covers is opened.



Note

Color calibration is automatically executed before the printer reverts to normal operation mode.

To confirm and change the timeout time, proceed as follows:

- 1 Press the **MENU** key.
- 2 Press the Δ or ∇ key repeatedly until `Others >` appears.

```
Others >
```

- 3 Press the \triangleright key.
- 4 Press the Δ or ∇ key repeatedly until `>Sleep Timer >` appears.

```
>Sleep Timer >
      030min.
```

- 5 To change the timeout time, press the **ENTER** key. A blinking cursor (|) appears.

```
>Sleep Timer
      030|min.
```

- 6** Press the Δ or ∇ key to increase or decrease the value at the blinking cursor and set the desired time. The timer can be set between 5 and 240 min, in 5-minute increments. Use the \triangleright and \triangleleft keys to move the cursor right and left.
- 7** When the desired timeout time is displayed, press the **ENTER** key.
- 8** To exit the menu selection, press the **MENU** key.

3.13.4 Received Data Dump

You can print data received by the printer as hexadecimal code for debugging programs and files.

- 1** Press the **MENU** key.
- 2** Press the Δ or ∇ key repeatedly until `Others >` appears.

```
Others >
```

- 3** Press the \triangleright key.
- 4** Press the Δ or ∇ key repeatedly until `> Print HEX-DUMP` appears.

```
>Print HEX-DUMP
```

- 5** Press the **ENTER** key. A question mark (?) appears.

```
>Print HEX-DUMP?
```

- 6** Press the **ENTER** key again. The message `Processing` appears for a second, followed by `Waiting`.

```
Processing
```



```
Waiting
```

- 7** While the message display is indicating `Waiting`, send data to be hex-dumped to the printer. The message display indicates `Processing` while the data is being received.

You can cancel printing of any more dump data by pressing the **GO** key and then the **CANCEL** key.

- 8** Once all data has been received, the message `Waiting` will appear. Press the **GO** key to finish hex-dump printing.

3.13.5 Printer Resetting

The procedure described below resets the printer's temporary conditions, such as the current page orientation, font, etc., set by commands to their default values. Downloaded fonts and macros are deleted from the printer's memory.

- 1** Press the **MENU** key.
- 2** Press the Δ or ∇ key repeatedly until `Others >` appears.

```
Others >
```

- 3** Press the \triangleright key.
- 4** Press the Δ or ∇ key repeatedly until `>Printer Reset` appears.

```
>Printer Reset
```

- 5** To reset the printer, press the **ENTER** key. A question mark (?) appears.

```
>Printer Reset ?
```

- 6** Press the **ENTER** key again. *Self test* appears while the printer is resetting itself, followed by *Please wait* and then *Ready*.

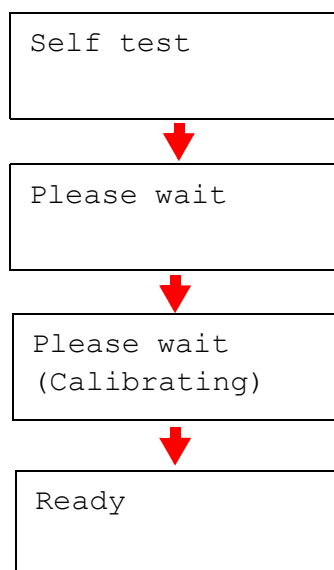

3.13.6 Resource Protection

By default, when you switch from the PCL 6 emulation to another, all downloaded fonts and macros will be lost. Resource protection preserves these PCL resources in memory so that they remain intact even when you have switched back in PCL 6.



Note

Resource protection requires extra memory to store the downloaded fonts and macros. The total size of the printer memory recommended for using the resource protection option is affected by several factors. See [Appendix A Options](#).

By default, resource protection is deactivated. To activate resource protection, proceed as follows:

- 1** Press the **MENU** key.
- 2** Press the Δ or ∇ key repeatedly until *Others >* appears.

```
Others >
```

- 3** Press the \triangleright key.

- 4** Press the Δ or ∇ key repeatedly until *>Resource Prot.* appears.

```
>Resource Prot.
  Off
```

- 5** Press the **ENTER** key. A blinking question mark (?) appears.

```
>Resource Prot.
? Off
```

- 6** Press the Δ or ∇ key to select *Permanent* or *Perm / Temp* (Permanent/Temporary) for resource protection.

- 7** When the desired resource protection is displayed, press the **ENTER** key.

- 8** To exit the menu selection, press the **MENU** key.

3.13.7 Alarm (Buzzer) Setting

You can set an alarm sound in addition to the message displayed when the paper supply is exhausted, or when paper jamming occurs. This setting is useful, for example, when the printer is located some distance from the user.

The audio alarm is set to *Off* when leaving the factory. If the alarm is set to *Off*, it will not sound.

- 1** Press the **MENU** key.
- 2** Press the Δ or ∇ key repeatedly until *Others >* appears.

```
Others >
```

- 3** Press the \triangleright key.

- 4** Press the Δ or ∇ key repeatedly until *Buzzer* appears.

```
>Buzzer
  Off
```

5 Press the **ENTER** key. A blinking question mark (?) appears.

```
>Buzzer
? Off
```

6 Select On or Off using the Δ or ∇ key.

7 Press the **ENTER** key.

8 To exit the menu selection, press the **MENU** key.

5 Press the **ENTER** key. A blinking question mark (?) appears.

```
>Auto Continue
Mode ? Off
```

6 Select On or Off using the Δ or ∇ key.

7 Press the **ENTER** key.

8 To exit the menu selection, press the **MENU** key. The display returns to Ready.

3.13.8 Auto Continue Setting

When Auto Continue is enabled, the printer will automatically print the next received data following a preset amount of time passes after any one of the following errors occurs:

- [Memory overflow Press GO]
- [Print overrun Press GO]
- [KPD L error Press GO]
- [File not found Press GO]
- [RAM disk error Press GO]
- [MemoryCard err Press GO]
- [Hard disk err Press GO]
- [Duplex disabled Press GO]
- [Add Staple Press GO]
- [Chad box full Press GO].

If one of the above errors is caused by someone on a network where the printer is being shared, for example, data sent from another person will be printed after a preset amount of time.

The default Auto Continue setting is Off (disabled).



For setting the auto continue recovery time, see the next section.

Note

1 Press the **MENU** key.

2 Press the Δ or ∇ key repeatedly until Others > appears.

```
Others >
```

3 Press the \triangleright key

4 Press the Δ or ∇ key repeatedly until Auto Continue > appears.

```
>Auto Continue >
Mode Off
```

3.13.9 Setting the Auto Continue Recovery Time

Follow the procedure given below to change the recovery time for Auto Continue.

1 Press the **MENU** key.

2 Press the Δ or ∇ key repeatedly until Others > appears.

```
Others >
```

3 Press the \triangleright key.

4 Press the Δ or ∇ key repeatedly until Auto Continue Mode > appears.

```
>Auto Continue >
Mode On
```

5 Press the \triangleright key and display >> Auto Continue Timer. The default setting is 30 seconds.

```
>>Auto Continue
Timer 030sec.
```

6 Press the **ENTER** key. A blinking cursor () appears.

```
>>Auto Continue
Timer 030sec.
```

7 Press the Δ or ∇ key to increase or decrease the value at the blinking cursor and set the desired time. The time must be set between 000 and 495 seconds, in 5-second increments. If set to 000, printing will be continued immediately without any time interval. You can use the \triangleright and \triangleleft keys to move the cursor right and left.

8 Display the desired time and press the **ENTER** key.

9 Press the **MENU** key. The display returns to Ready.

3.13.10 Duplex Printing Error Detection Setting

This setting is possible only when the optional DU-640 duplex unit is installed on the printer. This setting controls whether or not the message `Duplex disabled Press GO` appears when label or some other type of paper that is not supported for duplex printing is specified as the paper type when duplex printing is being performed.

When duplex printing error occurs when this setting is On:

- Press the **GO** key to perform simplex printing.
- Press the **CANCEL** key to cancel the print job.

When duplex printing error occurs when this setting is Off:

- Duplex printing is performed.

1 Press the **MENU** key.

2 Press the Δ or ∇ key repeatedly until `Others >` appears.

```
Others >
```

3 Press the \triangleright key.

4 Press the Δ or ∇ key repeatedly until `>Finishing Error >` appears.

```
>Finishing >
Error
```

5 Press the \triangleright key.

6 Press the Δ or ∇ key repeatedly until `>>Duplex Off` appears.

```
>>Duplex
Off
```

7 Press the **ENTER** key. A blinking question mark (?) appears.

```
>>Duplex
? Off
```

8 Press the Δ or ∇ key to change Off to On.

9 Press the **ENTER** key.

10 To exit the menu selection, press the **MENU** key.

3.13.11 Staple Error Detection Setting

This setting is possible only when the optional DF-600/610 finisher is installed on the printer. This setting controls whether or not the message `Add staples` appears when the finisher unit runs out of staples during output of a stabled job.

When the finisher runs out of staples while this setting is On:

- Message is displayed and printing pauses. Printing resumes automatically when staples are replenished.

When the finisher runs out of staples while this setting is Off:

- Message is displayed, but printing continues without stapling.

1 Press the **MENU** key.

2 Press the Δ or ∇ key repeatedly until `Others >` appears.

```
Others >
```

3 Press the \triangleright key.

4 Press the Δ or ∇ key repeatedly until `>Finishing Error >` appears.

```
>Finishing >
Error
```

5 Press the \triangleright key.

6 Press the Δ or ∇ key repeatedly until `>>Staple` appears.

```
>>Staple
  Off
```

7 Press the **ENTER** key. A blinking question mark (?) appears.

```
>>Staple
  ? Off
```

8 Press the Δ or ∇ key to change Off to On.

9 Press the **ENTER** key.

10 To exit the menu selection, press the **MENU** key.

5 Press the \triangleright key.

6 Press the Δ or ∇ key repeatedly until `>>Punch` appears.

```
>>Punch
  Off
```

7 Press the **ENTER** key. A blinking question mark (?) appears.

```
>>Punch
  ? Off
```

8 Press the Δ or ∇ key to change Off to On.

9 Press the **ENTER** key.

10 To exit the menu selection, press the **MENU** key.

3.13.12 Punch Error Detection Setting

This setting is possible only when the PH-3B Punch Unit is installed on the optional DF-610/610 finisher unit. This setting controls whether or not the message **Chad box full** appears when the chad box on the punch unit becomes full.

When the chad box becomes full while this setting is On:

- Message is displayed and printing pauses. Printing resumes automatically when the chad box is emptied and replaced back into the punch unit.

When the chad box becomes full while this setting is Off:

- Message is displayed, but printing continues without punching.

1 Press the **MENU** key.

2 Press the Δ or ∇ key repeatedly until `Others >` appears.

```
Others >
```

3 Press the \triangleright key.

4 Press the Δ or ∇ key repeatedly until `>Finishing Error >` appears.

```
>Finishing >
  Error
```

3.13.13 Mixed Color/Monochrome Print Setting

The printer has four color printing drums and developers (cyan, magenta, yellow, and black). The workload for each of these components are even regardless of which color is being used to print a job. When the printer prints a job which contains color pages and monochrome pages mixed together, you can choose to optimize the life of cyan, magenta, and yellow components or to ensure performance throughput.

You can select from the following options:

Mostly Monochrome	The printer switches to deactivate cyan, magenta, and yellow developing components to optimize the life of these components. This option may reduce throughput performance.
Mostly Color	The printer does not switch to deactivate any developing component while printing black-only pages. This provides maximum printing performance.
Auto	The printer automatically switches between Mostly Monochrome and Mostly Color options by looking-ahead-first manner.

The default setting is `Auto`.

1 Press the **MENU** key.

- 2** Press the Δ or ∇ key repeatedly until `Others >` appears.

```
Others >
```

- 3** Press the \triangleright key.

- 4** Press the Δ or ∇ key repeatedly until `>Color/Mono. mix` appears.

```
>Color/Mono. mix
```

- 5** Press the **ENTER** key. A blinking question mark (?) appears.

```
>Color/Mono. mix
? Auto
```

- 6** Press the Δ or ∇ key to select the setting you want.

- 7** Press the **ENTER** key.

- 8** Press the **ENTER** key. This display returns to `Ready`.

3.13.14 Printing the Service Status Page

The service status page contains printer settings information that is more detailed than the standard status page and is therefore mostly for service purposes. However, since there is a great deal of information on the service status page that may be useful to you, the procedure for printing it out is given below.

- 1** Press the **MENU** key.

- 2** Press the Δ or ∇ key repeatedly until `Others >` appears.

```
Others >
```

- 3** Press the \triangleright key.

- 4** Press the Δ or ∇ key repeatedly until `>Service >` appears.

```
>Service >
```

- 5** Press the \triangleright key.

- 6** Press the Δ or ∇ key repeatedly until `>>Print Status Page` appears.

```
>>Print
Status Page
```

- 7** Press the **ENTER** key. A question mark (?) appears.

```
>>Print
Status Page ?
```

- 8** Press the **ENTER** key. The display indicates `Processing` and printing starts.

3.13.15 Color Calibration

This printer contains a calibration function that automatically makes adjustments in compensation for secular changes that occur over time due to variations in the ambient temperature and humidity. So that the highest quality color printing can be maintained, this color calibration operation is carried out automatically each time the power to the printer is turned on. The color calibration operation may be carried out automatically during recovery from the Sleep mode or during printing.

- 1** Press the **MENU** key.

- 2** Press the Δ or ∇ key repeatedly until `Others >` appears.

```
Others >
```

- 3** Press the \triangleright key.

- 4** Press the Δ or ∇ key repeatedly until `> Service >` appears.

```
>Service >
```

- 5** Press the \triangleright key.

- 6** Press the Δ or ∇ key repeatedly until `>> Color Calibration` appears.

```
>>Color
  Calibration
```

- 7** To let the printer perform color calibration, press the **ENTER** key. A question mark (?) appears to let you confirm the execution of calibration.

```
>>Color
  Calibration ?
```

- 8** Press the **ENTER** key. The message display shows `Please wait (Calibration)` and calibration will start.

```
Please wait
(Calibration)
```

- 9** When calibration is finished, the display returns to `Ready`.

3.13.16 Using High Density Mode

When the high density data such as solid color or a page including many images is continuously printed, the printing density may lower. In such a case, you can prevent the printing density by changing the mode setting to the High Density Mode. However, if you perform the continuous printing in this high density mode, the printing speed will be reduced.



When the RAM disc of the printer is set to effective or a hard disc is attached to the printer, set the RAM disc or the hard disc to ON in the device setting menu of the printer driver. Otherwise, the high density mode will become invalid.

01	Standard (Initial setting)
02	Printing speed has a priority. Secure the appropriate printing density by controlling the reduction of the printing speed. If the density is a little discolored in the standard printing mode, use this mode.
03	Printing density has a priority. The printing density takes priority in printing operation so that the printing speed becomes slower than when 02 is selected.

- 1** Press the **MENU** key.
- 2** Press the Δ or ∇ key repeatedly until `Others >` appears.

```
Others >
```

- 3** Press the \triangleright key.
- 4** Press the Δ or ∇ key repeatedly until `> Service >` appears.

```
>Service >
```

- 5** Press the \triangleright key.

- 6** Press the Δ or ∇ key repeatedly until \gg High Density Mode appears.

```
>>High Density
Mode 01
```

- 7** Press the **ENTER** key. A blinking (?) appears

- 8** Press the Δ or ∇ key to select a number from 01 to 03.

```
>>High Density
Mode ? 01
```

- 9** Press the **ENTER** key.

- 10** Press the **MENU** key. The display returns to Ready.

Chapter 4 Troubleshooting

This chapter explains how to handle printer problems that may occur. If a problem cannot be corrected, contact your Kyocera Mita dealer. This chapter explains the following topics:

- *General Guidelines*
- *Print Quality Problems*
- *Error Messages*
- *Clearing Paper Jams*

4.1 General Guidelines

The table below provides basic solutions for problems you may encounter with the printer. We suggest you consult this table to troubleshoot the problems before calling for service.

Symptom	Check Items	Corrective Action
Print quality is not good.	See Section 4.2 Print Quality Problems on page 4-3 .	
Paper is jammed.	See Section 4.4 Clearing Paper Jams on page 4-12 .	
Nothing lights on the operator panel even when power is turned on and the fan makes no noise.	Check that the power cord is properly plugged into the power outlet.	Turn off the printer's power, plug in the power cord securely, and try turning on the printer's power again.
	Check that the power switch is in the On (I) position.	Set the power switch to the On position.
The printer prints a status page, but does not print jobs from the computer.	Check the printer cable or the interface cable.	Connect both ends of the printer cable securely. Try replacing the printer cable or the interface cable.
	Check program files and application software.	Try printing another file or using another print command. If the problem occurs only with a specific file or application, check the printer driver settings for that application.

Table 4-1

4.1.1 Tips

Printer problems may be solved easily by following the tips below. When you have encountered a problem that following the above guidelines will not solve, try the following:

- Turn the printer power off and wait for several seconds. Then, turn on the printer.
- Reboot the computer which sends the print jobs to the printer.
- Obtain and use the latest version of the printer driver. The latest versions of printer drivers and utilities are available at: <http://www.kyoceramita.com/download/>.
- Make sure that the procedures for printing are correctly followed in the application software. Consult the documentation supplied with the application software.
- If the printer prints garbage characters or stalls when the computer is turned on, particularly when the printer is connected to the computer under Windows 98 via the parallel port, rename device driver file drvwppqt.vxd. This file may be located in Windows\System\Iosubsys or Arcada\System folder. For technical details, visit Microsoft web site for the device driver.

4.2 Print Quality Problems

The tables and diagrams in the following sections define print quality problems and the corrective action you can conduct to solve the problems. Some solutions may require cleaning or replacing parts of the printer.

If the suggested corrective action will not solve the problem, call for service.

Printed Results	Corrective Action
Completely blank printout 	Check the toner containers. Open the printer front cover and check that the toner containers are correctly installed in the printer. For more information on installing the toner containers, see the separate <i>Installation Guide</i> supplied with the printer. Check that the application software is correctly operated.
All-black printout 	Call a service.

Table 4-2

Printed Results	Corrective Action
<p data-bbox="472 275 815 302">Black or white vertical streaks</p> 	<p data-bbox="963 275 1299 302">Check the operator panel for toner.</p> <p data-bbox="963 320 1457 432">If the Toner low (C/M/Y/K) message is displayed with color description, install a new toner kit for the color. To replace the toner container, see 5.1 Toner Container Replacement on page 5-2.</p>
<p data-bbox="472 790 743 817">Faint or blurred printing</p> 	<p data-bbox="963 790 1193 817">Clean the main charger.</p> <p data-bbox="963 835 1457 947">Open the printer front cover. Pull the green cleaning knob slowly in and out a few times. For full details, see 5.3.2 Cleaning the Main Charger Unit on page 5-7.</p> <p data-bbox="963 965 1457 1055">Make sure the paper type setting is correct the paper being used. See 3.10.4 Setting the Cassette Paper Type on page 3-50.</p> <p data-bbox="963 1072 1430 1126">Try adjusting the color control settings using the printer driver.</p> <p data-bbox="963 1144 1457 1234">Try switching the tone mode between Normal and Fine using the operator panel (Menu>Print Quality>Tone).</p> <p data-bbox="963 1252 1457 1341">Try changing the setting for the high density mode. For full details, see 3.13.16 Using High Density Mode on page 3-66.</p>
<p data-bbox="472 1507 671 1534">Gray background</p> 	<p data-bbox="963 1507 1442 1534">Try turning the printer off and then back on again.</p> <p data-bbox="963 1552 1193 1579">Clean the main charger.</p> <p data-bbox="963 1597 1457 1709">Open the printer front cover. Pull the green cleaning knob slowly in and out a few times. For full details, see 5.3.2 Cleaning the Main Charger Unit on page 5-7.</p> <p data-bbox="963 1727 1442 1753">Try turning the printer off and then back on again.</p>

Table 4-2 (Continued)

Printed Results	Corrective Action
Dirt on the top edge or back of the paper	<p>Clean the main charger.</p> <p>Open the printer front cover. Pull the green cleaning knob slowly in and out a few times. For full details, see 5.3.2 Cleaning the Main Charger Unit on page 5-7.</p> <hr/> <p>Check the inside of the paper transfer unit. Pull out the paper transfer unit, and make sure there is no toner or other foreign matter on the registration roller.</p> <hr/> <p>Check the transfer belt.</p> <p>If the transfer belt is dirty with toner, try printing several pages.</p>
	
Printing incomplete or out of position	<p>Check that the application software is correctly operated.</p>
	

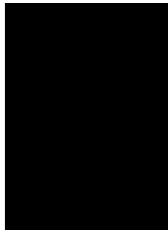
Table 4-2 (Continued)

4.3 Error Messages

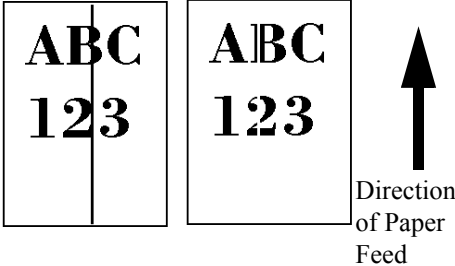
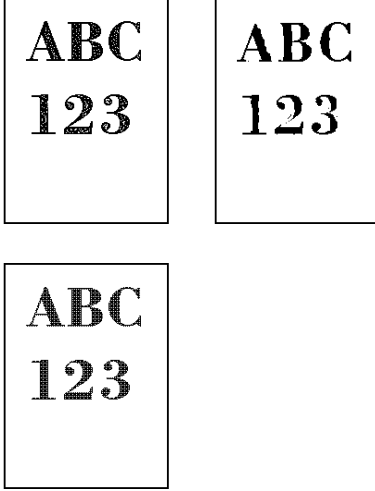
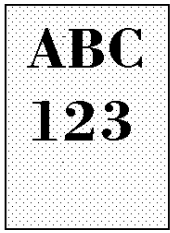
The following table lists errors and maintenance messages that you can be dealt with by yourself. If **Call service** appears, turn off the printer, disconnect the power cord, and contact your Kyocera Mita dealer.

Some errors cause the alarm sound to sound. To stop the alarm sound, press the **CANCEL** key to stop the alarm sound.

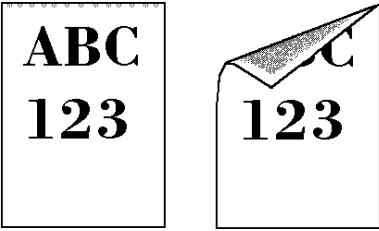
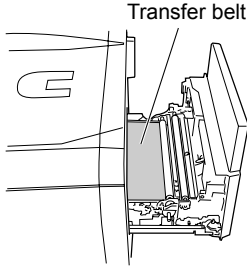
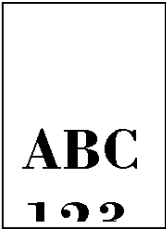
Message	Corrective Action
Add paper #####	The tray indicated in place of ##### has run out of paper. Supply paper to the applicable paper source (paper cassette or MP tray). This message is displayed alternately with messages indicating the printer status, such as, [Ready], [Please wait], [Processing], [Waiting], and [Form Feed Time Out]. If the number of copies to print is 2 or more, only the [Add paper] message is displayed.
Add staples	The optional finisher is out of staples. Replenish the staples.
Add staples Press GO	The optional finisher is out of staples. Replenish the staples. To continue printing without stapling, press the GO key.
Set MP Tray #####	When this message appears, place paper 2 sheets of the indicated size onto the MP tray and then press the GO key. In order to load the staples in place, the feed unit feeds the paper and the finisher operates without staples. Printing resumes automatically after the finisher operates without staples.
Add staples?	The optional finisher is out of staples. Pressing the ENTER key raises the finisher main tray, so replenish staples. Printing resumes automatically when staples are replenished.
Yes: Press ENTER No : Press GO	Pressing the GO key without replenishing staples continues printing without stapling.
Call service ####:0123456	A mechanical error has made further printer operation impossible. Make a note of the alphanumeric #### code, turn off power, unplug the printer, and contact your Kyocera Mita dealer or service representative. The value to the right of the code indicates the total number of pages printed.
Call service F###:	A printer controller error has made further printer operation impossible. Make a note of the F### number, turn off power, unplug the printer, and contact your Kyocera Mita dealer or service representative.
Call service F000	There is a problem with data transfer between the printer controller and operation panel. Turn off power, unplug the printer, and contact your Kyocera Mita dealer or service representative.
Cassette # not loaded	The indicated paper cassette is not installed. Correctly install the cassette. The indicated cassette number is 1 (topmost) to 5 (bottom). If the optional duplex drawer is installed, the indicated cassette number is 2 to 5.
Chad box full	The chad box is full. Empty the chad box.
Check chad box Press GO	Check the condition of the chad box. After ensuring that it is installed correctly, press the GO key.

Table 4-3

Message	Corrective Action
Check feed unit	The feed unit of the optional paper feeder is not installed correctly. Open the paper feeder paper cassette and correct the problem. This message appears only when the PF-647 paper feeder is installed on the printer.
Clean printer press GO	Clean the registration roller or main charger unit and then press the GO key. For details about cleaning, 5.3.1 Cleaning the Registration Roller on page 5-7 .
Close finisher cover	The cover of the optional document finisher (DF-600/610) is open. Close the cover.
Close front cover	The front cover is open. Close the cover.
Close left cover	The left cover of the printer is open. Close the cover.
Close right cover #	The indicated right cover of paper feeder is open. Covers are indicated by values in place of #, from 1 (topmost) to 3 (bottom). Close the applicable cover.
Duplex disabled Press GO	You trying to perform duplex printing while a paper size and/or type that is not allowed for duplex printing is selected. Press the GO key to print on one side of the paper only.
Duplex drawer not loaded	The duplex drawer of the optional Duplex Unit is not inserted correctly. Correct the problem and try again.
Face-down tray paper full	The face-down tray(which can hold approximately 500 sheets) is full. Remove all printed pages from the face-down tray. The printer will resume printing to the face-down tray when it detects that it is empty.
Feed unit not loaded	The feed unit of the optional paper feeder is not installed. Open the paper feeder paper cassette and correct the problem. This message appears only when the PF-647 paper feeder is installed on the printer.
File not found Press GO	The data you are trying to print from a virtual mailbox does not exist, or the virtual mailbox you specified does not exist. If Auto Continue is turned on, printing will resume resumed after a preset amount of time. For details about Auto Continue, refer to 3.10.8 Overriding Difference between A4 and Letter on page 3-53
Finisher tray ## paper full	The indicated (##) tray of the optional document finisher (DF-600/610) is full. Remove all printed pages from the tray.
Finisher path error	The optional document finisher (DF-600/610) is not installed properly. Correct the problem, referring to the instructions supplied with the document finisher.
Format error Memory Card	The memory card in printer's card slot is not formatted. To format a memory card, perform the procedure under Formatting a memory card on page 3-42 .
Format error Hard disk	The hard disk installed in the printer is not formatted. Format the hard disk following the procedure in the hard disk Installation Guide.
Hard disk err ## Press GO	A hard disk error of the type indicated by the error code that appears in place of ## has occurred. Refer to Storage error codes on page 4-11 for information about error codes. To ignore the hard disk error, press the GO key.

Table 4-3 (Continued)

Message	Corrective Action
I/F occupied	The interface whose setup you are trying to change is in use. Wait until the print job that is using the interface is finished, and try again.
ID error	The user ID entered for a private job or a stored job is not correct. Check to make sure you are using the same user ID that you specified with the printer driver.
Insert the same memory card	The memory card you inserted into the printer's memory card slot is the wrong one. Remove it, and then insert the correct memory card. Once the correct card is inserted, the printer will start reading it from the beginning of the data.
Install MK	Replace the Maintenance Kit. Replacement of the maintenance kit is necessary every 300,000 images of printing and requires professional servicing. Contact your Kyocera Mita dealer or service representative.
KPDL error ## Press GO	<p>Current print process cannot continue because of occurrence of a KPDL (PostScript Level 3 compatible page description language) error (type indicated by the number that appears in place of ##). To print an error report, use the mode menu to display <code>>Print KPDL err(s)</code>, and then select On. Press the GO key to resume printing. You can cancel the print job by pressing the CANCEL key.</p> <p>If Auto Continue is on, printing will resume automatically after a preset amount of time. For details about Auto Continue, refer to 3.13.8 Auto Continue Setting on page 3-62.</p>
Left tray paper full	The left (face-up) tray (which can hold approximately 150 sheets) is full. Remove all printed pages from the left tray. The printer will resume printing to the left tray when it detects that it is empty.
Load Cassette # (A4)/(PLAIN)†	<p>The indicated paper cassette (which contains paper that matches the size and type specified for the print job) is empty. Load paper into the paper cassette whose number is indicated in place of #. Next, press the GO key to resume printing.</p> <p>Note that the paper source number appears only when the optional paper feeder is installed.</p> <p>If you want to print from a different paper source, press the Δ or ∇ key to display <code>Use alternative</code> and you can change the source for paper feeding. After selecting a paper source and pressing the MENU key, <code>Paper Handling ></code> appears. By pressing the Δ key, the paper type settings menu appears. After setting the correct paper type, press the ENTER key and printing starts. For details, see 3.10.5 Selecting the Paper Feed Source on page 3-50.</p>
Load MP Tray (A4)/(PLAIN)†	<p>There is no paper cassette in the printer that matches the paper size and paper type of the print job. Load the proper type of paper onto the MP tray, and then press the GO key to resume printing.</p> <p>If you want to print from a different paper source, press the Δ or ∇ key to display <code>Use alternative</code> and you can change the source for paper feeding. After selecting a paper source and pressing the MENU key, <code>Paper Handling ></code> appears. By pressing the Δ key, the paper type settings menu appears. After setting the correct paper type, press the ENTER key and printing starts. For details, see 3.10.5 Selecting the Paper Feed Source on page 3-50.</p>
Memory card err Insert again	<p>The memory card in the printer's memory card slot was removed while it was being read. To continue reading the same memory card, insert it into the slot again. The printer will start reading the data from the beginning.</p> <p>Also see the Insert the same memory card message.</p>

Table 4-3 (Continued)

Message	Corrective Action
Memory overflow Press GO	The printer does not have enough memory. You can print a status page to check the current memory level. Try adding more memory. Press the GO key to resume printing. You can cancel the print job by pressing the CANCEL key. If Auto Continue is on, printing will resume automatically after a preset amount of time. For details about Auto Continue, refer to 3.13.8 Auto Continue Setting on page 3-62 .
MemoryCard err## Press GO	A memory card error of the type indicated by the error code that appears in place of ## has occurred. Refer to Storage error codes on page 4-11 for information about error codes. To ignore the memory card disk error, press the GO key.
Missing chad box	The chad box is not installed correctly. Install the chad box correctly.
Missing duplex drawer	The duplex unit is not installed. Install the duplex unit.
Missing folding unit	The optional folding unit is not installed correctly. Install the optional folding unit correctly.
Missing folding unit tray	The folding unit tray is not installed correctly. Install the folding unit tray correctly.
Missing toner container	Install the toner container of a toner kit for the color indicated in place of #. The printer will not operate while this message is displayed.
Color #####	
Missing waste toner box	The waste toner box is not installed. Install a waste toner box.
Paper jam #####	A paper jam has occurred at the location indicated in place of #####. For details, see Section 4.4 Clearing Paper Jams on page 4-12 .
RAM disk error## Press GO	A RAM disk error of the type indicated by the error code that appears in place of ## has occurred. Refer to Storage error codes on page 4-11 . To ignore the RAM disk error, press the GO key.
Remove paper Finisher tray ##	Paper remains in an option document finisher as displayed in place of ##. Remove printed pages.
Replace toner C, M, Y, K	Toner has run out in the indicated toner container(s). Replace the toner container using a new toner kit for the particular color. The printer will not operate while these two messages are alternating on the display. For example, if Replace toner C, K is displayed, replace the cyan and the black toner containers.
Replace toner Clean printer	
Replace waste toner box	The waste toner box is almost full. Replace it.

Table 4-3 (Continued)

4.3 Error Messages

Message	Corrective Action
Set paper press GO	The MP tray is out of paper. Load the proper type of paper onto the MP tray, and then press the GO key to resume printing.
Toner low C, M, Y, K	Replace the toner container of the indicated color (C: Cyan, M: Magenta, Y: Yellow, K :Black) using a new toner kit.
Virtual mail box full	The area in the hard disk allocated for virtual mailbox storage is full. Print out jobs currently stored in the virtual mailboxes.
Warning low memory	Printer internal memory is running low. Add more memory or delete unneeded fonts and macros.

Table 4-3 (Continued)

† Messages separated by ‘()/()’ are displayed alternately.

Storage error codes

Hard disk errors

Code	Meaning
01	Hard disk format error. If this error recurs even if the power has been turned off and then on, reformat the hard disk.
02	The disk system is not installed. Recheck the requirements for using the system and the devices.
04	There is no available hard disk space. Delete unnecessary files, etc., in order to free up space.
06	There is no memory available to the hard disk system. Increase the available memory.
10	Formatting is not possible because host data is being spooled on the hard disk. Wait until the hard disk is ready, and then format.
85	VMB: Alias error. The alias setting was lost, or the virtual tray corresponding to the alias does not exist. Set the alias again.
97	The number of permanent code jobs that can be stored reached the limit value, and no more can be saved. Either delete some unnecessary jobs, etc., or increase the limit.
98	An unreadable page was found in a job (The job is damaged.).
99	A print job for the specified ID does not exist in the hard disk.

Table 4-4

Memory card errors

Code	Meaning
01	The printer does not support the memory card inserted. The memory card must meet the requirements described in A.3.1 Memory Card on page -5 .
02	The memory card is not installed.
04	The memory card is full and cannot hold further data. Purge unnecessary files or use a new memory card.
06	Insufficient printer memory to support the memory card system. Expand printer memory.

Table 4-5

RAM disk errors

Code	Meaning
01	Format error. Try turning the power off and on again.
02	RAM disk mode is OFF. Turn RAM disk mode On from the operator panel.
04	No disk space. Purge unnecessary files.
06	Insufficient printer memory to support the RAM disk system. Expand printer memory.

Table 4-6

4.4 Clearing Paper Jams

If the paper jammed in the paper transport system, or no paper sheets were fed at all, the Paper jam message appears and the location of the paper jam (the component where the paper jam has occurred) is also indicated. The printer automatically goes off-line when this message is displayed. Remove jammed paper. After removing jammed paper, the printer will re-start printing.

4.4.1 Possible Paper Jam Locations

The figure below explains the printer's paper paths including the options, for example, the document finisher and the duplexer. The locations where paper jams might occur are also shown here, with each location explained in [Table 4-7](#) below. Paper jams can occur in more than one component on the paper paths.

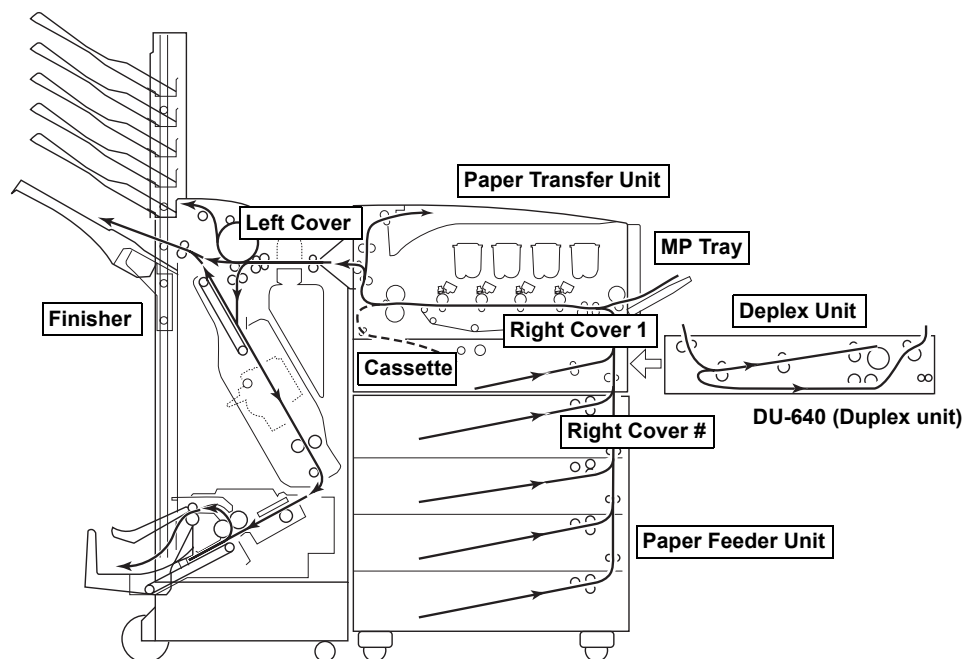

Figure 4-1

Location of Jam	See Page
Right Cover #	See 4.4.7 Paper Jam – Right Cover on page 4-15 .
Paper Trans Unit	
Cassette #	See 4.4.4 Paper Jam – Paper Cassette # on page 4-14 .
MP Tray	See Section 4.4.5 Paper Jam – MP Tray on page 4-14 .
Duplex Unit	See 4.4.6 Paper Jam – Duplex Unit on page 4-15 .
Right Cover 1	See 4.4.7 Paper Jam – Right Cover on page 4-15 .

Table 4-7

Location of Jam	See Page
Paper Feeder Unit	See 4.4.8 Paper Jam – Paper Feed Unit on page 4-16 .
Left Cover	See 4.4.9 Paper Jam – Left Cover on page 4-17 .
Finisher	See 4.4.10 Paper Jam – Option Unit on page 4-17 .

Table 4-7 (Continued)

4.4.2 General considerations for clearing jams

Bear in mind the following considerations when attempting jam removal:



When you remove paper jams, be sure to remove all of the jammed paper in the printer.

- If paper jams occur frequently, try using a different type of paper, replace the paper with paper from another ream, flip the paper stack over, or rotate the paper stack 180 degrees. Selection of paper is fully discussed in [Chapter 2 Handling Paper on page 2-1](#). The printer may have problems if paper jams recur after the paper was replaced.
- Whether or not the jammed pages are reproduced normally after printing is resumed depends on the location of the paper jam.

Utilizing online help messages

Online help messages are available in the printer's message display to provide simple instructions for clearing jams. Press the ? key when the paper jam message has appeared. Then a help message will appear to facilitate jam clearing in the location.

4.4.3 Paper Jam – Paper Feed

When a paper jam occurs in the printer or installed paper feeder as it leaves the cassette, open the right cover and remove the paper.

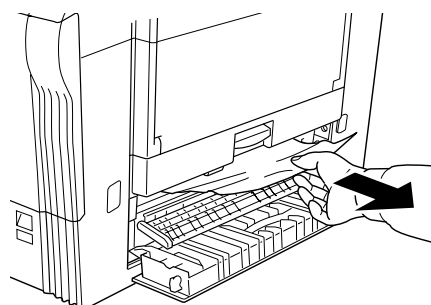

Figure 4-2

4.4.4 Paper Jam — Paper Cassette

When a paper jam occurs in a paper cassette, clear the jam using the following steps.

- 1** Pull out the paper cassette and remove the jammed paper.

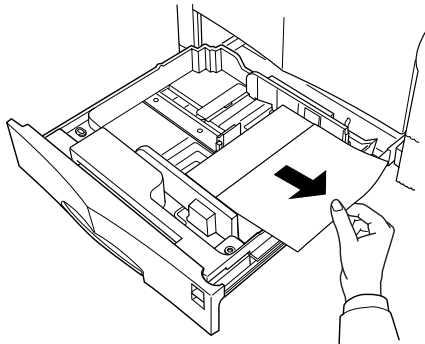

Figure 4-3

- 2** If you cannot remove the jammed paper as shown in step 1, remove the paper cassette from the printer.

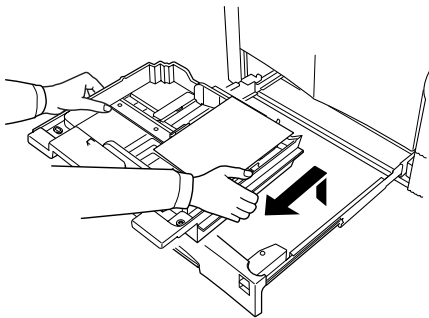

Figure 4-4

- 3** Pull the jammed paper from inside the printer.

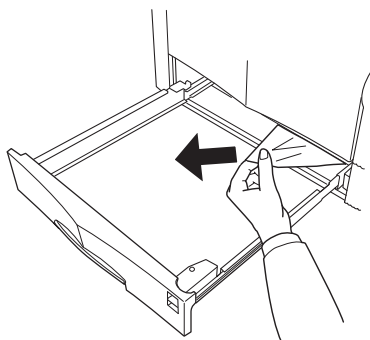

Figure 4-5

4.4.5 Paper Jam — MP Tray

The paper jammed in the MP tray. Clear the jam in the MP tray.

- 1** Remove the jammed paper on the MP tray up and towards the right.

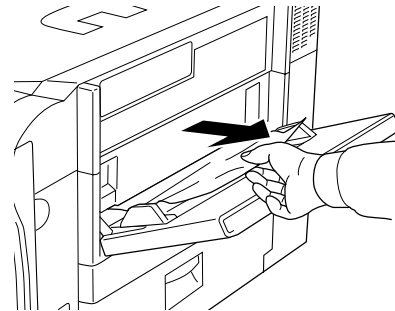

Figure 4-6

- 2** Reset the sheets on the MP tray.
- 3** Open and close the front cover to notify the printer of the completion of jam removal.

4.4.6 Paper Jam – Duplex Unit

When a paper jam occurs in the optional Duplex Unit, clear the jam using the following steps.

- 1** Pull out the duplex unit.
- 2** Open the top cover of the Duplex Unit and remove the jammed paper.

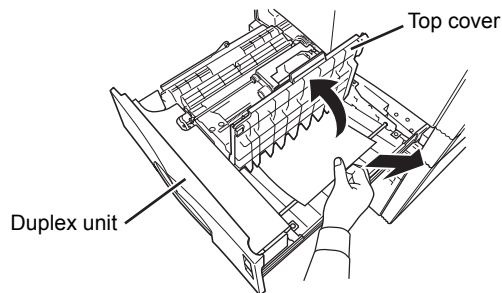

Figure 4-7

- 3** Pull the lever on the bottom of the Duplex Unit towards you, and open the bottom cover.

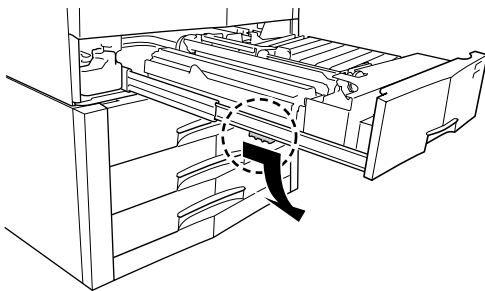

Figure 4-8

- 4** Remove the jammed paper.

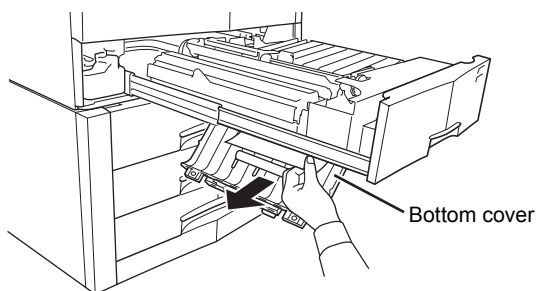

Figure 4-9

- 5** Close the bottom cover and top cover.
- 6** Slide the Duplex Unit back into the printer.

4.4.7 Paper Jam – Right Cover

When a paper jam occurs in the paper transfer unit or at the right cover, clear the jam using the following steps.

- 1** Pull the paper transfer unit handle and pull the unit out to the right.

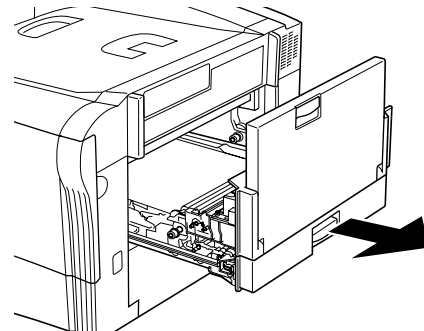

Figure 4-10

- 2** If the jammed paper is in the paper transfer unit, remove it.

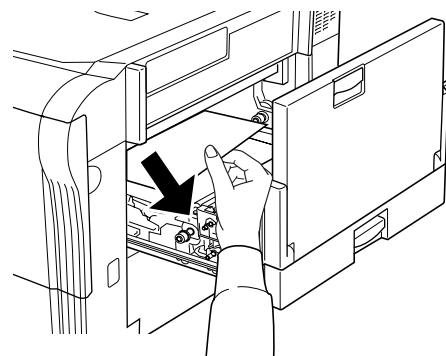

Figure 4-11

- 3** Push the green lever on the bottom of the transfer unit in the direction indicated by the arrow, and open the right cover.

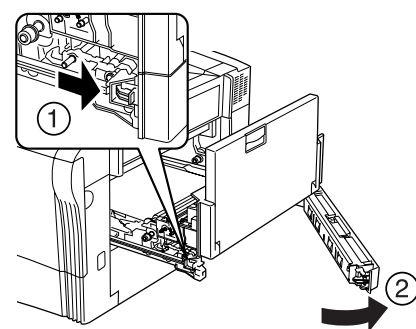

Figure 4-12

- 4** Remove the jammed paper.

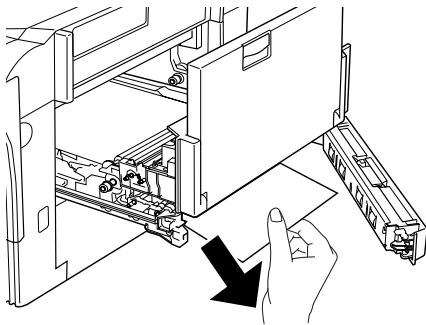

Figure 4-13

If the end of the paper is soiled with toner, pull it in the direction indicated by the arrow to remove it.

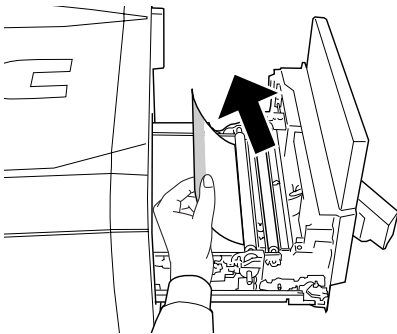

Figure 4-14

- 5** Pressing the handle of the transfer unit, return the transfer unit securely to its original position.

4.4.8 Paper Jam – Paper Feed Unit

This type of paper jam occurs only when the optional large-capacity paper feeder unit is installed on the printer.

- 1** Pull out the paper cassette.

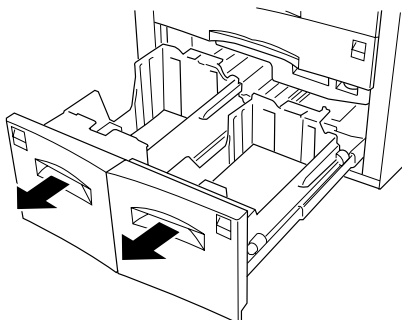

Figure 4-15

- 2** Pull out the paper feed unit.

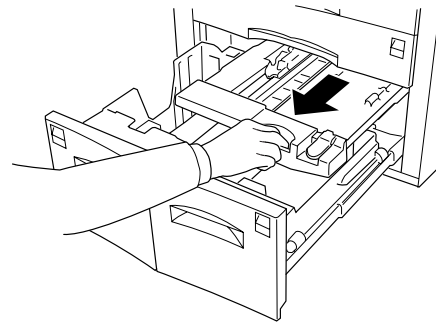

Figure 4-16

- 3** Raise the lever, and then remove the jammed paper.

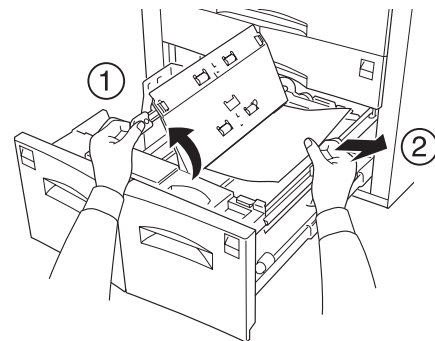

Figure 4-17

- 4** Return the paper feed unit back into the printer, and then close the paper cassette.



Note

Push the paper feed unit in until it locks in place with a click. Return the paper transfer unit back into the printer.

4.4.9 Paper Jam – Left Cover

When a paper jam occurs at the left cover, clear the jam using the following steps.



Note

The fuser unit and rollers become very hot during normal use. Never touch them with your hands.

- 1 Open the left cover, and then rotate the green knob to remove the jammed paper.

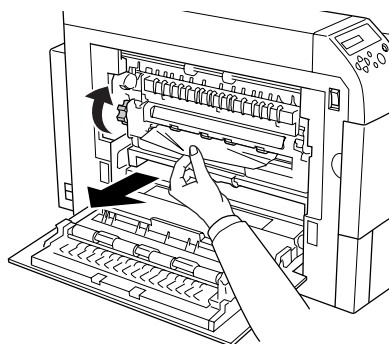

Figure 4-18

- 2 If you cannot remove the jammed paper this way, pull the two green lock levers towards you and then open the fuser unit cover.

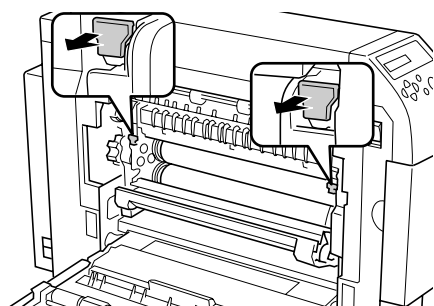

Figure 4-19

- 3 While rotating the green knob, remove the jammed paper.

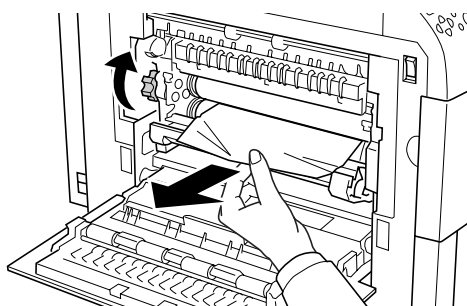

Figure 4-20

- 4 If you still cannot remove the jammed paper, close the fuser unit cover. While raising the green lever at the bottom of the fuser unit, pull the fuser unit out of the printer.

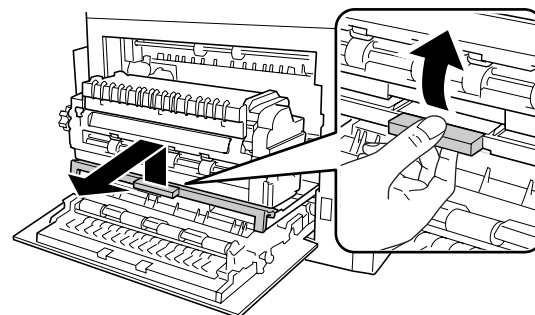

Figure 4-21

- 5 Remove the jammed paper from behind the fuser unit.

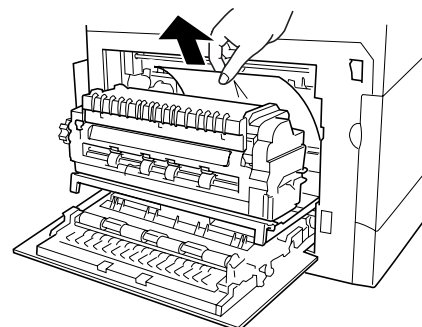

Figure 4-22

- 6 Return the fuser unit back into the printer, and then close the left cover.

4.4.10 Paper Jam – Option Unit

Use the procedures provided in the user documentation that comes with the document finisher to clear any paper jam that occurs inside it.

Chapter 5 Maintenance

This chapter describes the following basic printer maintenance tasks you can perform.

- Toner container replacement
- Waste toner box replacement
- Cleaning

5.1 Toner Container Replacement

5.1.1 Toner Container Replacement Requirements

The actual life of a toner container depends on the amount of toner you use for printing your particular documents. With about 5% coverage (a typical business document) and printing on A4 or letter size paper, landscape orientation, a toner container can print approximately 20,000 images. The actual number of images that can be copied depends on the content of the images.

You can print a status page to check how much toner you have remaining in each toner container. For details, see [3.3.2 Printing a Status Page on page 3-17](#).

Starter toner containers

The toner containers packed with the new printer are starter toner containers. The starter toner containers lasts an average of 6,000 pages under the conditions described above.

Toner kits

To prevent printer troubles and ensure a long printer life, use of the new Kyocera Mita TK-811 Toner Kit supplied from Kyocera Mita is strongly recommended.

The TK-811 Toner Kits are available in each of the following four colors.

TK-811C	Cyan
TK-811M	Magenta
TK-811Y	Yellow
TK-811K	Black

An TK-811 toner kit for each color contains the following items.

- Toner Container
- Waste toner box
- Cleaning cloth
- Grid cleaner
- Plastic waste bags for old toner container and old waste toner box
- Instructions



Note

Do not remove the toner container from the carton until you are ready to install it in the printer.

- **When replacing toner containers, keep them away from floppy diskettes, etc.**

- **Always clean the interior of the printer after replacing a toner container. See [5.3 Cleaning the Printer on page 5-7](#) for more information.**

5.1.2 Toner Container Replacement Request

The printer displays messages for individual colors at two stages of toner usage. This message is automatically alternated with the other printer message (such as Ready):

- When the printer becomes low on toner, for example in the cyan container, the printer displays the message `Toner low C, M, Y, K` as the first caution. Note the replacement is not always necessary at this stage.
- If you ignore the above message and continue printing, the printer displays the message `Replace Toner`—just before the toner is used up. The toner container must be replaced immediately. Clean the separate charger wires, etc. After the cleaning is finished, however, the message does not automatically change to `Ready`. To restart printing, you must press the **GO** key and make the printer ready.

In either case, to replace the toner container, see [Section 5.1 Toner Container Replacement on page 5-2](#).

5.1.3 Replacing the Toner Container



Note

During toner container replacement, temporarily put storage media and computer supplies (such as floppy disks) away from around the toner container. This is to avoid damaging media by the magnetism of toner.

This section explains how to replace the toner containers. When replacing the toner container of any color, always replace the waste toner box at the same time. If this box is full, the printer may be damaged or contaminated by the waste toner that may spill over the box.



Note

You do not have to turn printer power off before starting the replacement. Any data that may be under printing process in the printer will be deleted if you turn printer power off.

To replace the toner container, first make sure of the color of the toner container requiring replacement. In this example, it is assumed that you are replacing the black toner container.

- 1 Open the front cover.

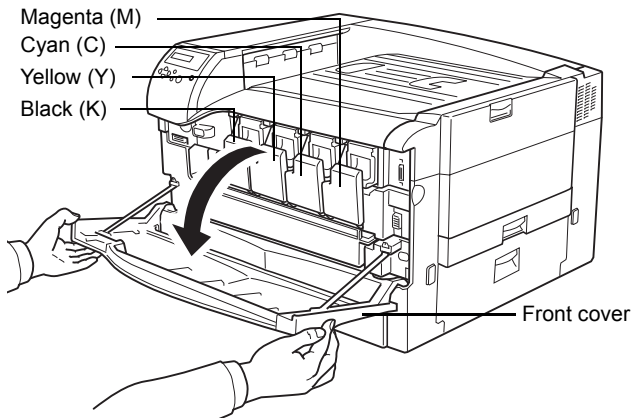

Figure 5-1

- 2 Press on the toner container to open it.

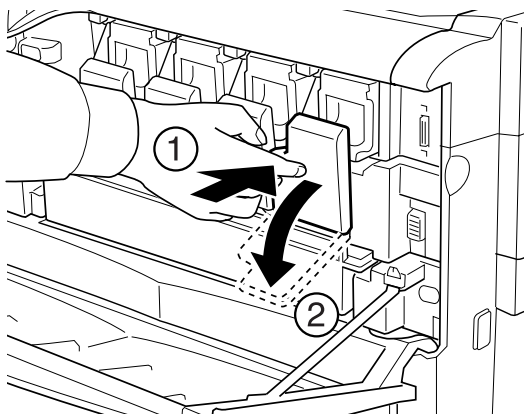

Figure 5-2

- 3 While pressing the green lock lever, unlock the container. This will cause the toner container to move towards you slightly. Carefully lift up and pull to remove it.

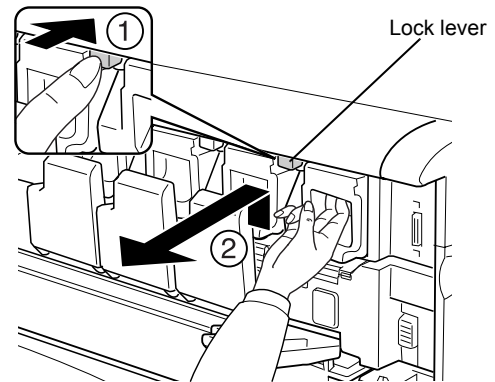

Figure 5-3

- 4 Put the old toner container in the plastic waste bag (contained in the toner kit) and discard it later according to the local code or regulations for waste disposal.

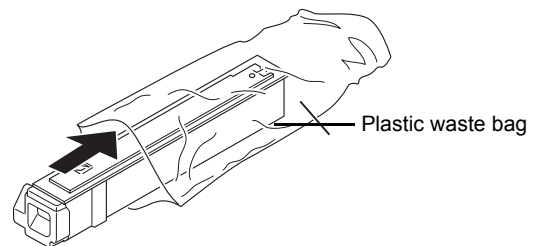

Figure 5-4

- 5 Take the new toner container out of the toner kit.
- 6 To loosen and redistribute the toner inside, hold the container and shake the container back and forth at least 5 times.

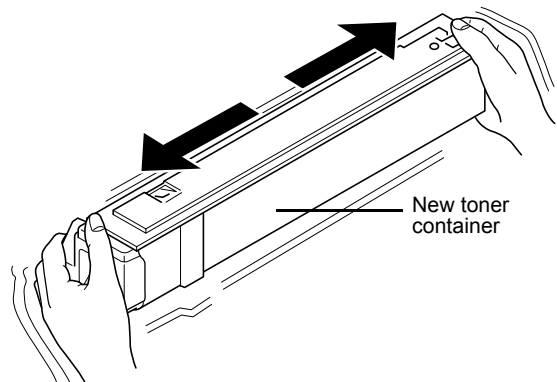

Figure 5-5

5.1 Toner Container Replacement

- 7** Insert the new toner container all the way in. The container is locked automatically when it is properly seated.

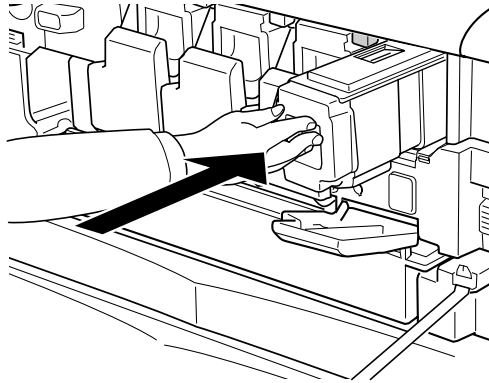

Figure 5-6

- 8** Close the toner container cover, and then close the front cover. Press the left and right corners of the front cover to ensure that it is closed securely.

To replace the other color toner container, use the same procedure above.

Proceed to the next section and replace the waste toner box.

5.2 Replacing the Waste Toner Box

When `Replace waste toner box` is shown in the message display, replace the waste toner box. A new waste toner box is included with the toner kit.

- 1 While pressing the lock lever to the left, pull out the left end of the waste toner box and then remove the waste toner box.

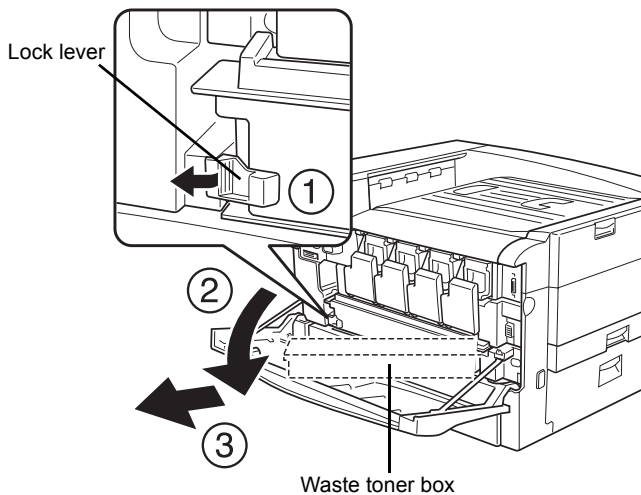

Figure 5-7

- 2 To keep toner from spilling, remove the black caps provided on the tone toner box and insert them into the four holes as shown in the illustration below.

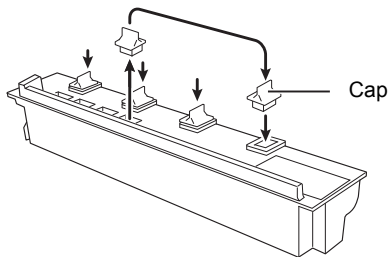

Figure 5-8

- 3 Put the old waste toner box in the plastic waste bag (contained in the toner kit) and discard it later according to the local code or regulations for waste disposal.

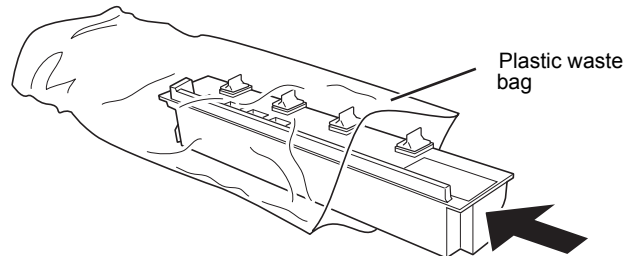

Figure 5-9

- 4 Check to make sure that the caps of the new waste toner box are open.

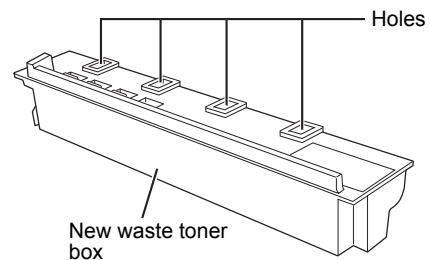

Figure 5-10

- 5 Install a new waste toner box into the printer as shown in the illustration.

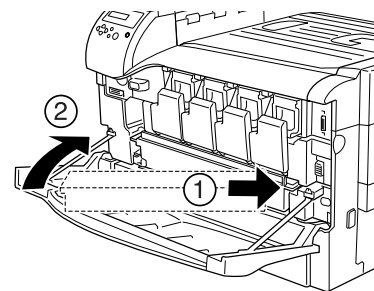
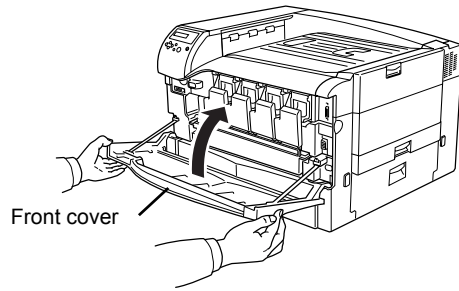

Figure 5-11

- Do not cover the holes of the new waste toner box with their covers. Doing so will lead to malfunction of the printer.

6 Close the front cover.



When Replace waste toner box is shown in the message display, replace the waste toner box. A new waste toner box is included with the toner kit. Always clean the interior of the printer after replacing a toner container. See [5.3 Cleaning the Printer on page 5-7](#) for more information.

5.3 Cleaning the Printer

As discussed earlier, the following parts must be cleaned each time the toner container and waste toner box are replaced:

- Paper transfer unit
- Main charger unit

In addition to this, it is recommended that these parts are cleaned periodically at least once a month.

5.3.1 Cleaning the Registration Roller

A dirty registration roller can cause soiling of the reverse side of the paper and other printing problems. Use the following procedure to clean the registration roller.



Note

Be careful not to touch the transfer belt (black) or to place anything on top of the transfer belt during cleaning. Doing so can cause poor print quality.

- 1 Pull the paper transfer unit handle and pull it out to the right.

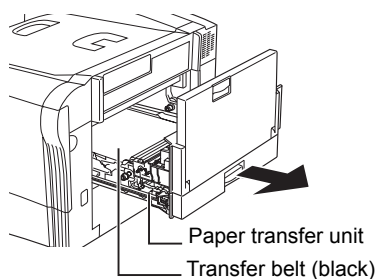

Figure 5-12

- 2 Use the cleaning cloth that comes with the toner kit to wipe any paper particles from the metal roller.

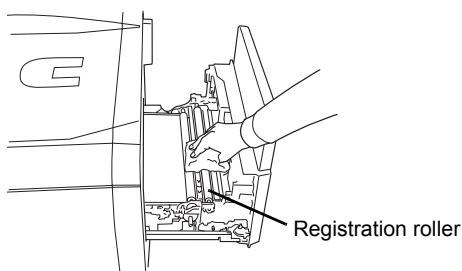

Figure 5-13

- 3 Pressing the handle of the transfer unit, return the transfer unit securely to its original position.

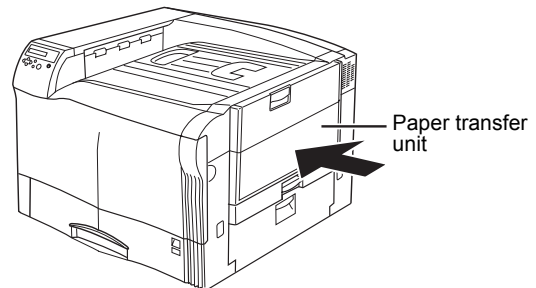

Figure 5-14

5.3.2 Cleaning the Main Charger Unit

The main charger unit needs to be cleaned periodically as it gets contaminated with dioxide after a long usage. The main charger is comprised of two main parts — the wire and the grid — which should be cleaned separately as instructed below.

To clean the main charger unit, proceed as follows:

- 1 Open the front cover.

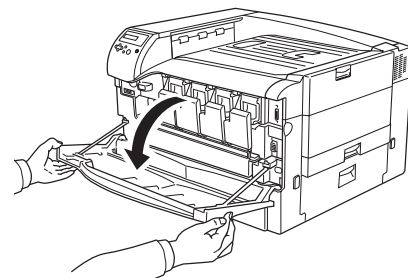

Figure 5-15

- 2 Press on the toner container to open it.

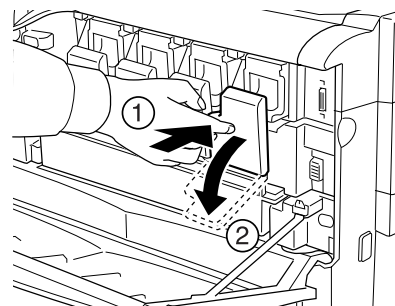

Figure 5-16

- 3** First we clean main charger wire. Grasp the tab of the cleaning knob (green-colored). Gently pull the cleaning bar out and push it back in. Repeat this 3 to 5 times.

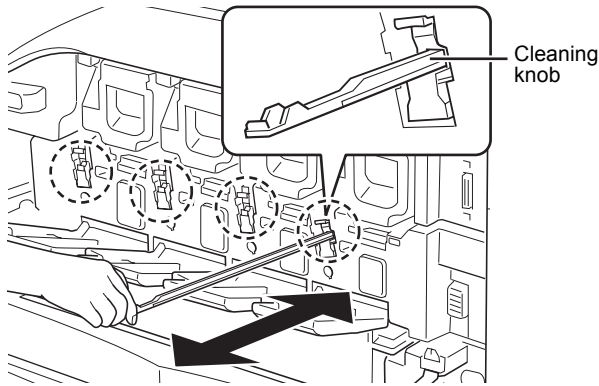

Figure 5-17

- 4** Next, we clean main charger grid. Take the grid cleaner out of the toner kit. Take the grid cleaner out of the protective bag and remove the cap.

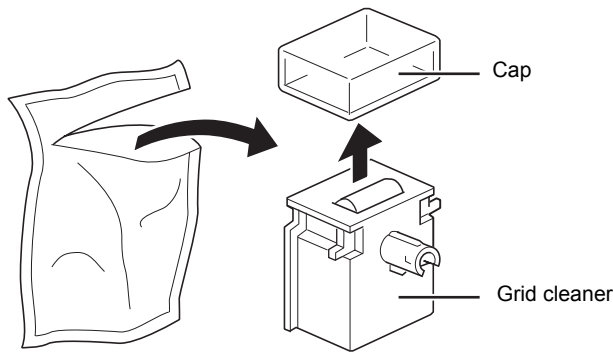

Figure 5-18



Note The pad of the grid cleaner contains water. Clean the grid quickly so that the pad may not dry off.

- 5** Attach the grid cleaner to the printer with the pad facing up.

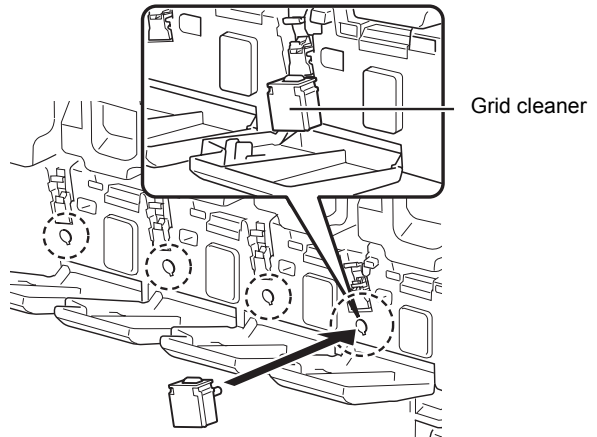

Figure 5-19

- 6** While slightly raising the charger unit, slowly pull it out and push it back in two or three times. This cleans the grid on the bottom of the charger unit.

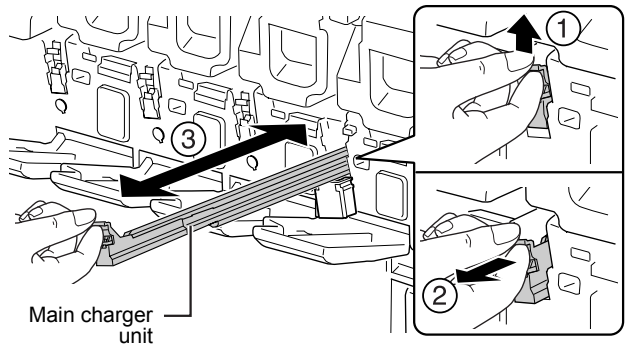

Figure 5-20

- 7** After cleaning is finished, remove the grid cleaner from the printer and discard it. The grid cleaner cannot be reused.

- 8** After cleaning the charger wire and grid, check to make sure that the charger unit is back in its original position, and then close the toner container cover and front cover.

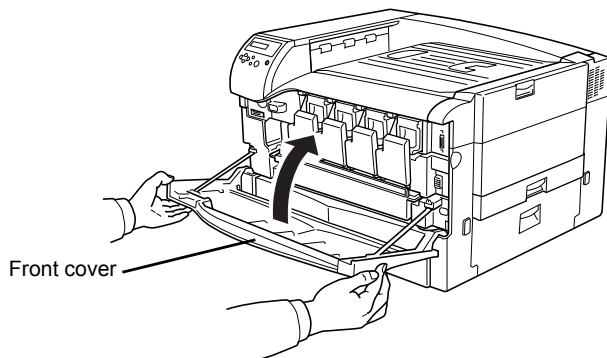

Figure 5-21



Note

If the front cover does not fully close, although the printer shows *Ready*, open the front cover and push the main charger unit until it is fully inserted in the printer.

Appendix A Options

Your printer can be installed with various options indicated in this appendix.
You can select the options that will satisfy your printing requirements.
For availability of the options, consult your Kyocera Mita dealer.

A.1 Options

The following shows the options that can be installed on the FS-C8026N printer. Though some options are explained in the following pages of this Appendix, see the document that comes with each option for detailed information that is not provided here.

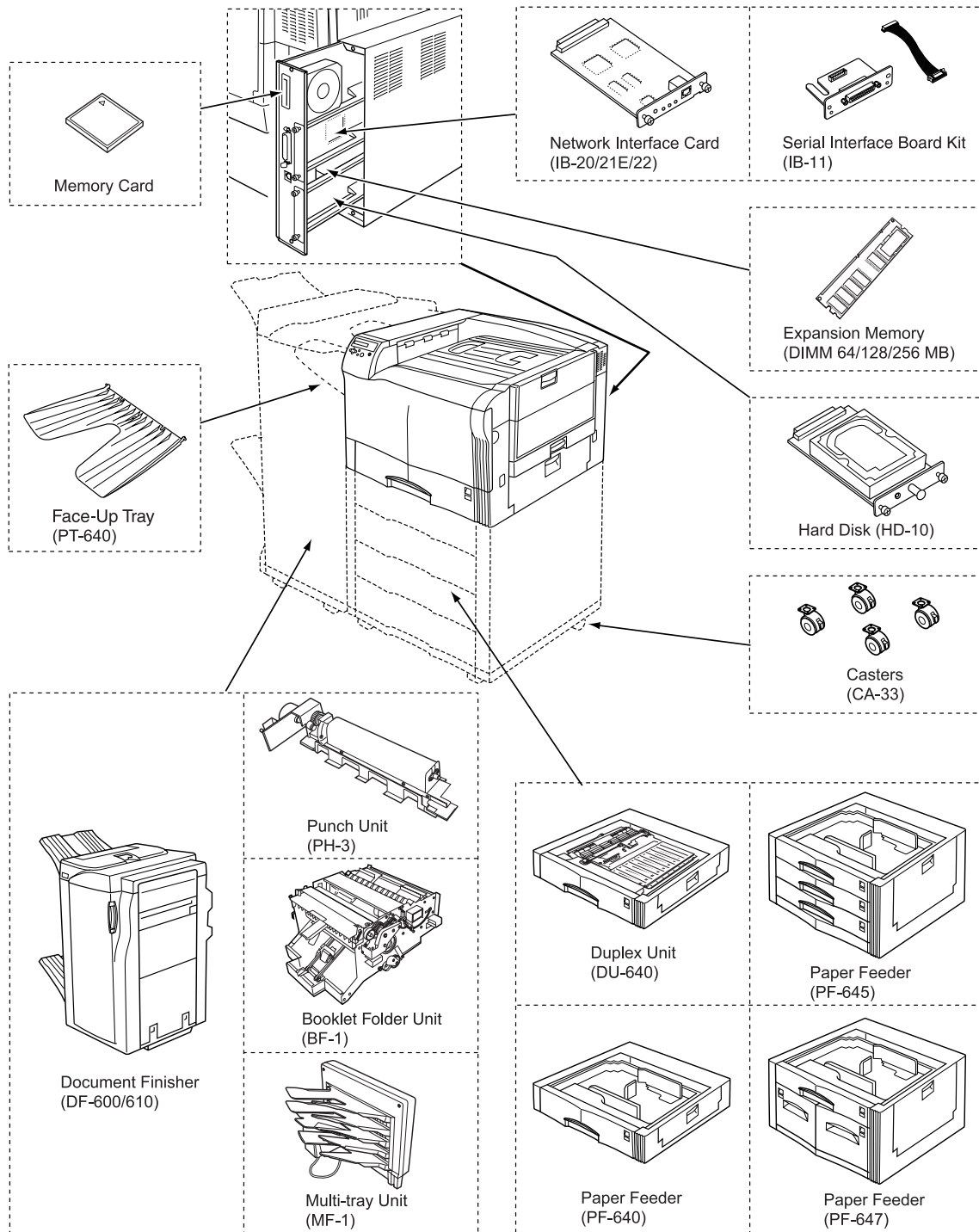

Figure A-1

A.2 Expansion Memory Modules

Expanding printer memory lets you print more complex data, and also makes printing faster. The FS-C8026N printer has a single memory expansion slot, which you can use to expand memory up to a maximum of 512MB.



Note

Only an authorized Kyocera Mita dealer should install the expansion memory. Kyocera Mita shall not be liable for any damages caused by improper installation of expansion memory.

To expand memory up to 512MB, remove the 128MB memory module that is installed at the factory and install two 256MB memory modules.

Precautions on handling the printer's main controller board and memory modules

- To protect electronic parts, discharge static electricity from your body by touching a water pipe (faucet) or other large metal object before handling the memory modules. Or, wear an antistatic wrist strap, if possible, when you install the memory modules.
- Always hold the main controller board or a memory module by its edges as shown below to avoid damaging electronic parts.

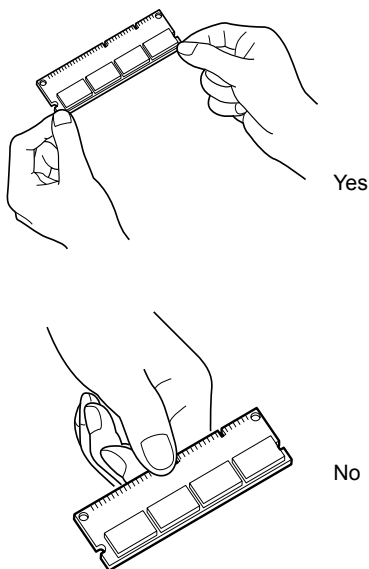

Figure A-2

A.2.1 Installing the Memory Modules

- 1 Power off the printer and unplug the printer power cord.

- 2 Unscrew two screws at the back of the main controller board.

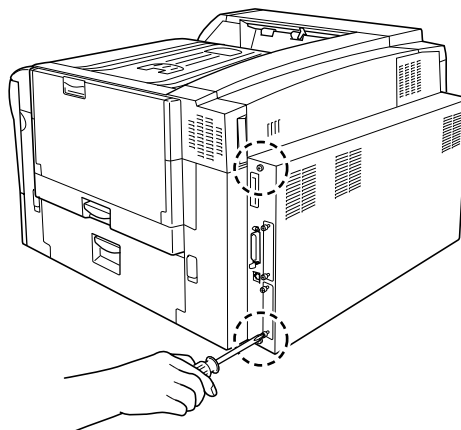

Figure A-3

- 3 Pull out the main controller board gently.

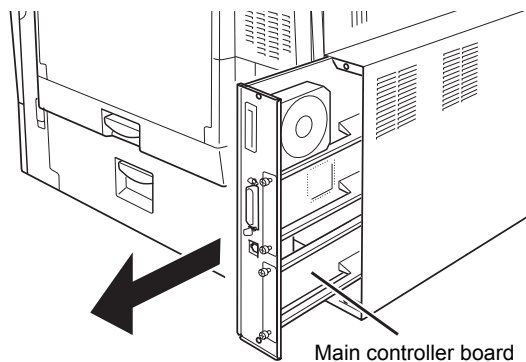

Figure A-4

- 4 Push out the clamps on both ends of the memory socket on the main controller board.

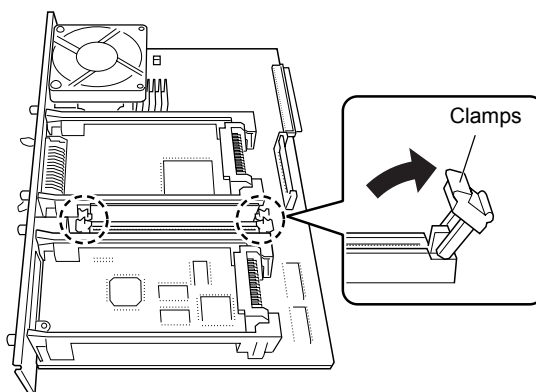

Figure A-5

- 5 Remove the memory module from its package. Aligning the cutouts of the memory module with the matching keys of the socket, carefully plug the memory module into the memory socket until it clicks in place.

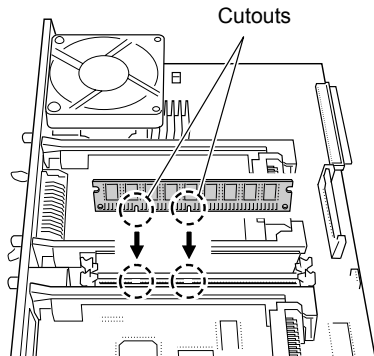

Figure A-6

- 6 Push down the two socket clamps to secure the memory modules.

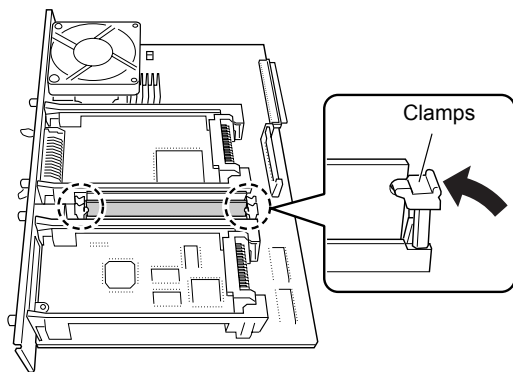

Figure A-7

- 7 After you finish installing the memory modules, reinstall the main controller board and fasten it with screws.

Removing a memory module

To remove a memory module, remove the main controller board, then carefully push out the two socket clamps. Ease the memory module out of the socket to remove.

Testing the expanded memory

To verify that the memory modules are working properly, test them by printing a status page. To print a status page:

- 1 Make sure the printer is switched off. Plug in the printer power cord into an AC outlet and power on the printer.

- 2 Wait until the printer becomes Ready. When ready, press the **MENU** key.
- 3 Press the ∇ key repeatedly until the message display shows `Print Status Page`.
- 4 Press the **ENTER** key twice. A status page is printed.

Check the **Memory** field in the upper right area. It shows information about the memory modules installed in memory slots 1 and 2. If you see an increase in the total memory size, the installation is successful. (Note that the printer is shipped with 128 MB of base memory.)

A.3 General Description of Options

A.3.1 Memory Card

The printer is equipped with a slot for a memory card with the maximum size of 256 MB. A memory card is useful for storing fonts, macros, and overlays. You can use the **IC Link for Windows** utility to download fonts, etc., to a memory card. This software is included in the CD-ROM supplied with the printer.

Reading font from the memory card

Once inserted in the printer's slot, the contents of the memory card can be read from the control panel or automatically when you power on or reset the printer. To manually read data in the memory card, see [3.9.1 Using the Memory Card on page 3-42](#).



Before inserting a memory card in the printer, make sure that the printer is switched off.

Insert the memory card in the memory card slot.

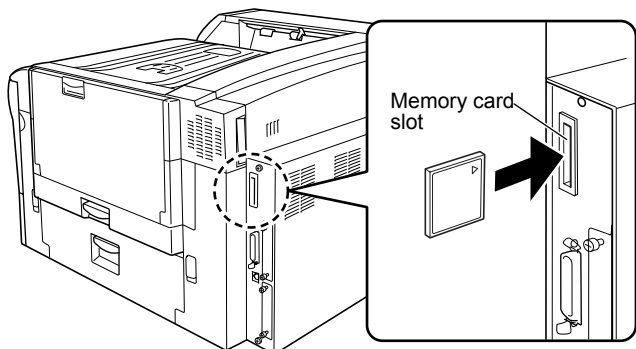
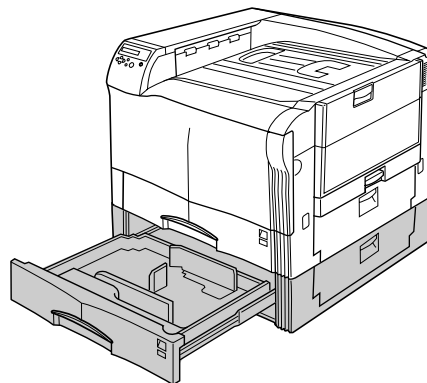

Figure A-8

A.3.2 PF-640/645/647 Paper Feeders

The optional Paper Feeder fits underneath the printer as shown in the illustration (The PF-647 is shown as an example.). In combination with the printer's paper cassette, each model provides a capacity of indicated below. All of the optional paper cassettes that come with the paper feeder support use of the following paper types: ISO A3, ISO A4, ISO A5, JIS B4, JIS B5, Ledger, Letter, and Legal.

For detailed information on installing the paper feeder, see the manual supplied with the paper feeder.



PF-640:500 sheets

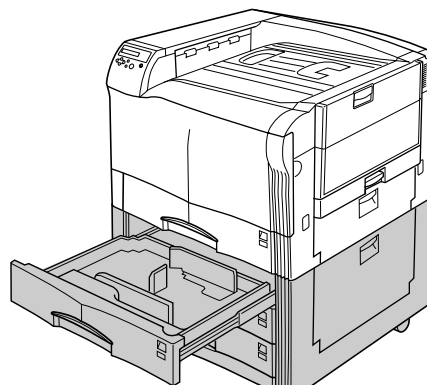

PF-645:1500 sheets

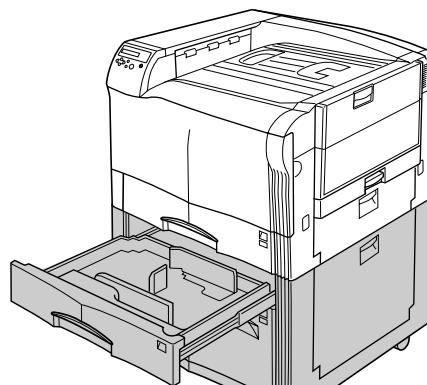

PF-647:3000 sheets

Figure A-9

A.3.3 PT-640 Face-Up Tray

Attach the optional Face-Up Tray to the left side of the printer as shown in the illustration. Use of the Face-Up Tray help to avoid stress to the printer and print media when printing on envelopes, postcards, OHP transparencies, etc.

The Face-Up Tray can hold up to 150 sheets.

To secure the two tray brackets to the side of the printer, attach the tray to the brackets using the screws supplied with the Face-up tray.

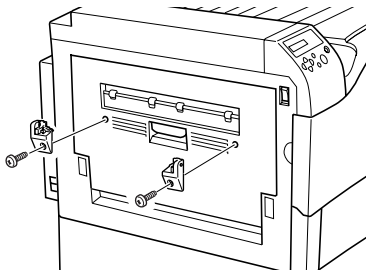

Figure A-10

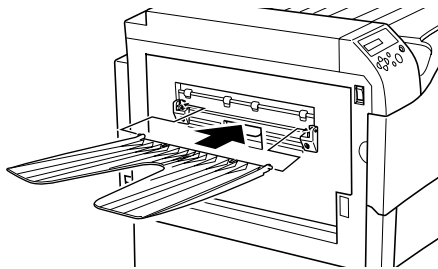

Figure A-11

A.3.4 DU-640 Duplex Unit

The optional Duplex Unit supports the following paper types for duplex printing: ISO A3, ISO A4, ISO A5, JIS B4, JIS B5, Leger, Letter, and Legal. The Duplex Unit is installed under the printer, as shown in the illustration below. See the documentation that comes with the Duplex Unit for details about how to install it.

For detailed information on installing the duplex unit, see the manual supplied with the duplex unit.

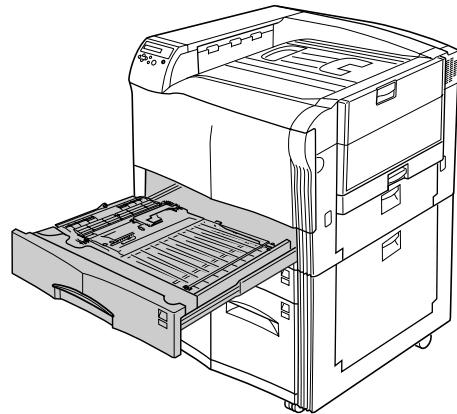

Figure A-12

A.3.5 DF-600/610 Document Finishers

The Document Finisher makes it possible to staple pages as they are output, and to stagger printed pages according to print job. An optional punch unit, Booklet Folder Unit, and multi-job trays are also available for configure this multi-function device to meet specific needs.

The Document Finisher attaches to the left side of the printer as shown in the illustration. Use the special bracket that comes with the Document Finisher to attach it to the printer.

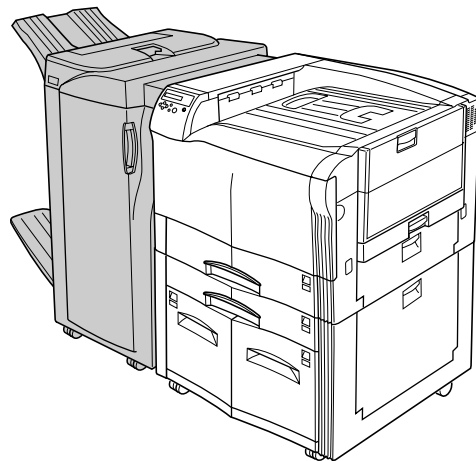

Figure A-13

A.3 General Description of Options

The following optional devices can be installed on the document finisher.

	DF-600	DF-610	
Punch Unit PH-3B	No	Yes	Punches holes as pages are output.
Booklet Folder Unit BF-1	No	Yes	Outputs pages with center folds.
Multi-tray Unit MF-1	Yes	Yes	User-specific output to five trays.

Table A-1

A.3.6 CA-33 Caster Kit

These casters are mounted at the bottom of the bottom feeder for moving or fixing the printer. The CA-31 is the regular casters that may be used for the standalone FS-C8008 series printers, including only the standard PF-30A paper feeder or PD-800 duplex unit. The CA-31B is the topple-resistant, heavy-duty caster kit. The CA-31B must be installed when the printer is installed with one or more extra paper feeders.



Caution

The manufacturer is not liable for any damages or injuries that may be caused when the CA-31B is not used to support the printer having more than one paper feeders.



Note

If the floor is delicate against casters, when this product is moved after installation, the floor material may be damaged.

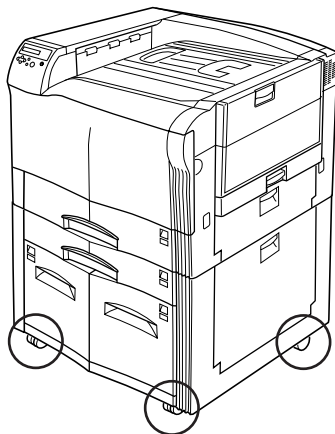

Figure A-14

A.3.7 Hard Disk

The hard disk is used for saving print data. This is advantageous when printing multiple sets of copies, as high-speed printing is possible using the electronic sorting function. The hard disk is further required in order to use the e-MPS function. You can use the **KM-NET Printer Disk Manager** utility to keep track of the stored data. This software is included in the CD-ROM supplied with the printer.

The hard disk is inserted into the hard disk slot (**HDD**) on the back of the printer as shown in the illustration.

The hard disk must be formatted before the initial use. To format the hard disk, use the printer operator panel or the **KM-NET Printer Disk Manager**. Before you install the hard disk in the printer, power off the printer and unplug the power cord.

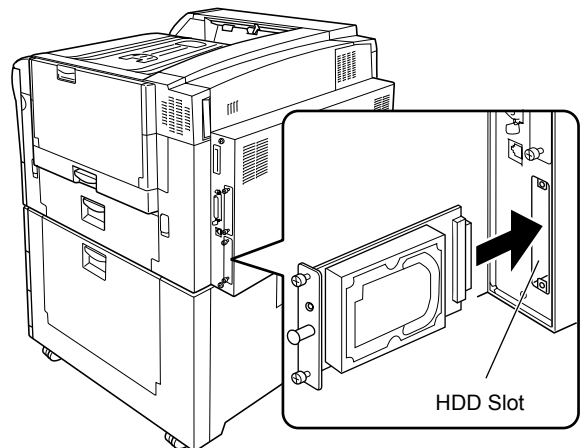

Figure A-15

A.3.8 IB-20/IB-21E/IB-22 Network Interface Cards

Along with the standard for the network interface on the printer, the network interface card supports TCP/IP, IPX/SPX, NetBEUI and EtherTalk protocols, so that the printer can be used on network environments including Windows, Macintosh, UNIX, NetWare, etc. Install the network interface card in the **OPT** slot located on the lower right side of the printer rear as shown below.

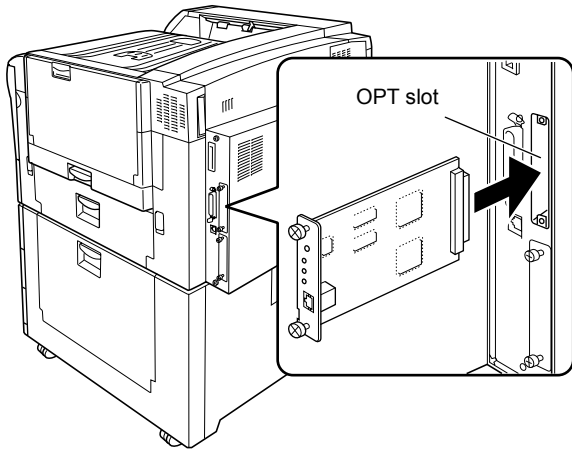

Figure A-16

Network interface card	Network connections
IB-20	10Base-T/100Base-TX/10Base-2
IB-21E	10Base-T/100Base-TX
IB-22	IEEE802.11b (Wireless)

Table A-2

Appendix B Computer Interface

This appendix explains the pin assignments, signals, timing, connectors, and other specifications for printer's parallel interface.

B.1 Parallel Interface

B.1.1 Communication Modes

The printer provides high-speed data transmission on a parallel interface. You can select the parallel interface communication mode from the operation panel. To change communication mode, see [3.5.1 Changing Parallel Interface Mode on page 3-28](#).



Note

Use a parallel interface cable that complies with the IEEE 1284 standard.

You can choose from four communication modes:

Communication Mode	Reception	Transmission
Auto (default)	High-speed/ECP	Nibble/ECP
Nibble	High-speed	Nibble
High-speed	High-speed	—
Normal	Normal	—

Table B-1

B.1.2 Interface Signals

Table shows the connector pins and corresponding input and output signals of the parallel interface. Explanation of each signal is also given in the table.

The description in [] indicates signal names in Auto mode and Nibble (high) mode (IEEE 1284-compliant). In Auto and Nibble modes, these signals are bidirectional.

Pin	In or out	Signal	Description
1	In	Strobe [†] [nStrobe]	A negative-going-strobe pulse causes the printer to read and latch the data on the Data 0 [1] to Data 7 [8] signal lines.
2	In	Data 0 [Data 1]	These eight signals form one byte of data sent from host computer to printer. Data 7 [8] is the most significant bit.
3	In	Data 1 [Data 2]	
4	In	Data 2 [Data 3]	
5	In	Data 3 [Data 4]	
6	In	Data 4 [Data 5]	
7	In	Data 5 [Data 6]	
8	In	Data 6 [Data 7]	
9	In	Data 7 [Data 8]	
10	Out	Acknowledge [†] [nAck]	This negative-going pulse acknowledges the previous character received.
11	Out	Busy [Busy]	When this signal is high, the printer is busy. When it is low, the printer is able to receive more data.
12	Out	Paper Empty [PError]	This signal goes high when the printer runs out of paper. ^{††}
13	Out	Online (Select) [Select]	This signal goes high when the printer is online and low when the printer is offline. The signal goes low when you press the GO key to make the printer go off line. ^{††}
14	In	[nAutoFd]	Ignored
15	—	—	Not used
16	—	0 V DC	
17	—	Chassis Ground	
18	—	+5 V DC	This pin is used for the printer's +5 V DC power supply (+5±0.5 V, 400 mA maximum, with fuse)
19	—	Ground return	
20	—	Ground return	
21	—	Ground return	
22	—	Ground return	
23	—	Ground return	
24	—	Ground return	
25	—	Ground return	
26	—	Ground return	
27	—	Ground return	
28	—	Ground return	
29	—	Ground return	

Table B-2

Pin	In or out	Signal	Description
30	—	Ground return	
31	In	[nInit]	Ignored
32	Out	Error [†] [nFault]	When the high-speed parallel line control is on, this line returns an error status. ^{††}
33	—	—	Not used
34	—	—	Not used
35	Out	Power Ready	This signal goes high when the printer is powered on.
36	In	Select In [nSelect In]	When this line is high, IEEE1284 mode is enabled.

Table B-2

[†] Indicates signals that are low active.

^{††} The Paper Empty, Online, and Error signals work only after you have enabled them using the O2 parameter of the FRPO command.

Appendix C Technical Specifications

The technical specification may be changed for improvement purpose.

C.1 Printer Specification

Item		Specification
Printing method		Electro photographic (Advanced Beam Array) single-pass 4-color tandem drum system
Printing speed		See C.2 Printing Speeds on page C-4
Resolution		600 dpi (horizontal and vertical)
First print (A4, 23°C)		Approximately 9 seconds (priority mode)
Warm up time (23°C)		179 seconds or less
Main Controller CPU		PowerPC 750CXe (600 MHz)
Main Memory		128 MB, expandable up to 512 MB maximum
Expansion Memory Module		64, 128, 256 MB (for 2 slots)
Operating System		Windows 95/98/Me, Windows NT/2000/XP, Macintosh, Linux
Protocol Support		IPX/SPX, TCP/IP, EtherTalk, NetBEUI
Interfaces	Parallel	IEEE1284, 1
	Network	10Base-T/100Base-TX, 1
	Optional	Network Interface Card, Serial Interface Board, 1 Hard Disk, 1
Memory Card Slot		Compact flash memory card, maximum 256 MB
Self-diagnostics		Performed at power-on
Maximum Duty Cycle (for standard dry A4 plain paper)		100,000 pages per month
Imaging Drum		Amorphous silicon drum
Developers		Dual-component dry developers
Main Charger		Positive scorotron charger
Transfer		Belt and Roller
Separation		Small ratio curvature separation
Drum Cleaning		Counter blade
Drum Discharging		LED array
Fuser		Heat rollers
Paper		See 2.1.2 Paper specifications on page 2-2 .
Paper Sizes	Cassettes	A3, B4, A4, B5, A5, Ledger, Legal, Letter
	Multi-purpose Tray	80 × 148mm to 310 × 458 mm
Unprintable Area		4 mm margin top, bottom, left, right
Paper Capacity	Cassettes	500 sheets (80 g/m ²)
	Multi-purpose Tray:	150 sheets (75 g/m ²)/30 sheets (160 g/m ² or more)
Output Tray Capacity		500 sheets (80 g/m ²)

Table C-1

Item		Specification	
Operating environment	Temperature	10 to 32.5 °C (50 to 90.5 °F)	
	Relative humidity	20 to 80 %	
	Optimum Conditions	23°C (73°F), 60 % (relative humidity)	
	Altitude	2,000 meters (6,500 feet) maximum	
	Illumination	1,500 lux or less	
Power Requirements	U.S.A. and Canada	120V, 60 Hz, 12.5 A max	
	Europe, Asia, and other countries	220 to 240 V, 50 or 60 Hz, 6.5 A max.	
	Allowable Voltage Fluctuation	± 10 % maximum	
	Allowable Frequency Fluctuation	± 2 % maximum	
Power Consumption	U.S.A and Canada	Maximum	1,350 W
		Normal Operation	700 W
		Standby	165 W
		Sleeping	30 W
	Europe, Asia, and other countries	Maximum	1,450 W
		Normal Operation	700 W
		Standby	165 W
		Sleeping	30 W
Noise [†]	Printing	LpA = 53 dB (A)	
	Standby	LpA = 39 dB (A)	
	Sleeping	LpA = 35 dB (A)	
Dimensions	699 mm wide × 463 mm high × 715 mm deep		
Weight	84.3 kg		

Table C-1 (Continued)

[†] In accordance with ISO 7779 (Bystander Position, sound pressure level at the front)

C.2 Printing Speeds

Mode	Paper Size	Print Speed
Simplex Printing	A4, Letter, B5 (Paper cassette feeding)	26 pages/minute
	A4, Letter, B5 (MP tray feeding)	24 pages/minute
	B4	13 pages/minute
	A3, Legal	13 pages/minute
	Ledger	11 pages/minute
	A4 thick (Paper cassette feeding)	13 pages/minute
	A4 thick (MP tray feeding)	12 pages/minute
	Transparency (MP tray feeding)	13 pages/minute
Duplex printing [†]	A4, Letter	24.5 pages/minute
	A3, Legal, B4, B5	13 pages/minute
	Ledger	11 pages/minute

Table C-2

[†] Requires the DU-640 duplex unit.

Index

A

- Audible alarm
 - how to set 3-61
- Auto-continue
 - changing recovery time 3-62
 - how to set 3-62

C

- Carriage return
 - how to select 3-39
- Cleaning
 - main charger unit 5-7
 - paper transfer unit 5-7
 - using the grid cleaning tool 5-8
- Color control
 - selecting monochrome or color printing 3-56
- Counters
 - reading the life counters 3-57
 - reading the total printed pages 3-57
 - toner, how to reset 3-57

D

- Data dump
 - receiving data for damping 3-60
- Document finisher 3-52
 - option, diagrammed A-6
- Duplex printing
 - binding modes 3-51
 - description 3-51
- Duplex unit
 - option, diagrammed A-6

E

- e-MPS
 - as software feature 1-3
 - changing configuration 3-25
 - general information 3-20
 - how to change hard disk spaces 3-25
 - printing a list of code jobs 3-24
- Emulation
 - appearing on the status page 3-19
 - KC-GL, setting pen width and color 3-32
 - KPDL, printing errors 3-33
 - KPDL, setting the alternative emulation 3-33
 - setting the default using the operator panel 3-32
- Envelope
 - requirements 2-11

Error log

- on the status page 3-19

Error messages

- of hard disk 4-11
- of memory card 4-11
- of RAM disk 4-11
- tabled, with corrective actions 4-6

F

- Face-down tray
 - location and function 1-6
- Font
 - adjusting character pitch for fixed fonts 3-36
 - changing the default size 3-35
 - printing lists of fonts 3-36
 - sample of the font list 3-37
 - selecting regular or dark Courier/Letter Gothic 3-35
 - setting the default using the operator panel 3-34
- Formfeed
 - changing timeout time 3-58

G

- Gloss mode
 - how to select 3-40

H

- Handling 2-1
- Hard disk
 - as an option A-7
 - deleting data 3-44
 - formatting 3-42
 - location of the slot 1-8
 - writing data 3-43

I

- Indicators
 - Interface 3-3
 - Paper Size 3-4
 - Paper Type 3-5
 - Ready, Data, Attention 3-5

J

- Job retention
 - functions tabled 3-20
 - private job, how to use 3-22
 - proof-and-hold, how to use 3-22
 - quick copy, how to use 3-21
- Job storage
 - functions 3-21

K

- Keys
 - arrow keys 3-7
 - basic operation 3-6
 - Cancel 3-6
 - Enter 3-7
 - Go 3-6
 - Menu 3-7
- KPDL3
 - as software feature 1-3

L

- Label
 - required composition 2-9
 - requirements 2-10
- Linefeed
 - how to select 3-39

M

- Memory
 - expanding memory A-3
 - installing memory modules A-3
 - on the status page 3-19
- Memory card
 - deleting data 3-44
 - formatting 3-42
 - inserting in the slot A-5
 - location of the slot 1-8
 - writing data 3-43
- Menu map
 - how to print 3-15
 - sample 3-16
- Menu selection system
 - road map 3-8
- Message display
 - changing the language 3-58
 - for replacing toner containers 5-2
 - indicators included 3-3
 - Online help messages 4-13
 - status information 3-2

MP tray

- clearing paper jam 4-14
- first mode, cassette mode 3-48
- location and function 1-5
- setting the paper size 3-48
- setting the paper type 3-49

N

- Network interface
 - a sample of the network status page 3-31
 - interface cards, diagrammed A-8
 - location of the slot 1-8
 - printing a network status page 3-31
 - protocols and parameters 3-29
 - resolving the IP address 3-30
- Number of copies
 - how to select 3-38

O

- Online help messages
 - for clearing paper jams 4-13
- Operator panel
 - configuring the printer defaults 3-32
 - diagram 3-2
 - function 1-5, 3-2
- Options
 - a list of, diagrammed A-2
- Orientation
 - how to select 3-38
- Output device
 - how to select 3-55
- Override A4/Letter
 - description 3-53

P

- Paper
 - available paper 2-2
 - basic requirements 2-5
 - colored 2-11
 - envelopes 2-11
 - guidelines for choice 2-4
 - label 2-9
 - minimum and maximum sizes 2-3
 - other properties 2-6
 - paper sizes tabled, as Paper Size indicator 3-4
 - paper types, as Paper Type indicator 3-5
 - recycled 2-11
 - special paper 2-9
 - specifications, tabled 2-2
 - standard sizes 2-4
 - transparencies 2-9

Paper cassette
as hardware feature 1-3
clearing paper jam 4-14
diagram 1-5
selecting the paper feed source 3-50
setting paper type 3-50

Paper feeder
diagrammed A-5

Paper jam
general considerations 4-13
messages and corrective actions, diagrammed 4-14
possible locations, diagrammed 4-12

Paper type
creating custom 3-53
how to create custom paper types 3-53
resetting the custom paper type 3-54

Parallel interface
changing parallel interface mode 3-28
connector, location 1-8
signals and definitions B-3
understanding the modes B-2

Partition
a sample of the partition list 3-45
printing a list of 3-45

PRESCRIBE
as software feature 1-3

Print quality
Gloss mode 3-40
Tone mode 3-40

Printing problems
general guidelines tabled 4-2
print quality problems, blank printing, etc. 4-3

R

RAM disk
setup 3-42

Reset
resetting the printer 3-60

Resource protection
description 3-61

S

Serial interface
changing parameters 3-28

Setting the Timer 3-59

Sleep timer
setting the timer 3-59
setting timeout time 3-59

Status page
how to print 3-17
understanding 3-18

Stitch position 3-52

Storage device
reading fonts from 3-42
reading/writing 3-43
writing data 3-43

T

Tone mode
description 3-40
how to select 3-40

Toner containers
diagram 1-7
how to replace 5-2
kits 5-2
replacement 5-2
replacement, messages 5-2
service life 5-2
starter containers 5-2

Transparency
recommended makes and types 2-9

V

Virtual mailbox
functions 3-21
how to change the maximum space 3-27
printing a list of mailboxes 3-24
retrieving jobs from 3-24

W

Waste toner box
location and replacement 5-5

KYOCERA MITA EUROPE B.V.

Hoeksteen 40, 2132 MS Hoofddorp,
The Netherlands
Phone: +31.(0)20.654.000
Home page: <http://www.kyoceramita-europe.com>
Email: info@kyoceramita-europe.com

KYOCERA MITA NEDERLAND B.V.

Hoeksteen 40 2132 MS Hoofddorp
The Netherlands
Phone: +31.(0)20.587.7200

KYOCERA MITA (UK) LTD.

8 Beacontree Plaza
Gillette Way,
Reading Berks RG2 0BS, UK
Phone: +44.(0)118.931.1500

KYOCERA MITA ITALIA S.P.A.

Via Verdi 89 / 91 20063 Cernusco sul Naviglio,
Italy
Phone: +39.02.92179.1

S.A. KYOCERA MITA BELGIUM N.V.

Hermesstraat 8A 1930 Zaventem Belgium
Phone: +32.(0)2.720.9270

KYOCERA MITA FRANCE S.A.

Parc Les Algorithmes
Saint Aubin
91194 GIF-SUR-YVETTE
France
Phone: +33.(0)1.6985.2600

KYOCERA MITA ESPAÑA S.A.

Edificio Kyocera, Avda de Manacor N. 2,
Urb. Parque Rozas 28290 Las Rozas,
Madrid, Spain
Phone: +34.(0)91.631.8392

KYOCERA MITA FINLAND OY

Kirvesmiehenkatu 4 00810 Helsinki,
Finland
Phone: +358.(0)9.4780.5200

KYOCERA MITA (SCHWEIZ) AG

Holzliwisen Industriestrasse 28
8604 Volketswil, Switzerland
Phone: +41.(0)1.908.4949

KYOCERA MITA DEUTSCHLAND GMBH

Mollsfeld 12 D-40670 Meerbusch,
Germany
Phone: +49.(0)2159.918.0

KYOCERA MITA GMBH AUSTRIA

Eduard-Kittenberger Gasse 95
1230 Wien, Austria
Phone: +43.(0)1.86338.0

KYOCERA MITA SVENSKA AB

Box 1402 171 27 Solna, Sweden
Phone: +46.(0)8.546.550.00

KYOCERA MITA NORGE

Postboks 150 Oppsal, NO 0619 Oslo
Olaf Helsetsvei 6, NO 0694 Oslo
Phone: +47.(0)22.62.73.00

KYOCERA MITA DANMARK A/S

Hovedkontor: Slotsmarken 11,
DK-2970 Hørsholm, Denmark
Phone: +45.(70)22.3880

KYOCERA MITA PORTUGAL LDA.

Rua do Centro Cultural, no 41 1700-106
Lisbon, Portugal
Phone: +351.(0)21.842.9100

KYOCERA MITA SOUTH AFRICA (PTY) LTD.

527 Kyalami Boulevard,
Kyalami Business Park 1685 Midrand South
Phone: +27.(0)11.466.3290

KYOCERA MITA AMERICA, INC.

Headquarters:

225 Sand Road,
Fairfield, New Jersey 07004-0008,
U.S.A.
Phone: (973) 808-8444

KYOCERA MITA AUSTRALIA PTY. LTD.

Level 3, 6-10 Talavera Road, North Ryde,
N.S.W. 2113 Australia
Phone: (02) 9888-9999

KYOCERA MITA NEW ZEALAND LTD.

1-3 Parkhead Place, Albany
P.O. Box 302 125 NHPC, Auckland,
New Zealand
Phone: (09) 415-4517

KYOCERA MITA (THAILAND) CORP., LTD.

9/209 Ratchada-Prachachem Road,
Bang Sue, Bangkok 10800, Thailand
Phone: (02) 586-0320

KYOCERA MITA SINGAPORE PTE LTD.

121 Genting Lane, 3rd Level,
Singapore 349572
Phone: 67418733

KYOCERA MITA HONG KONG LIMITED

11/F., Mita Centre,
552-566, Castle Peak Road,
Tsuen Wan, New Territories,
Hong Kong
Phone: 24297422

KYOCERA MITA TAIWAN

Corporation.

7F-1~2, No.41, Lane 221, Gangchi Rd.
Neihu District, Taipei, Taiwan, 114. R.O.C.
Phone: (02) 87511560

KYOCERA MITA Corporation

2-28, 1-chome, Tamatsukuri, Chuo-ku
Osaka 540-8585, Japan
Phone: (06) 6764-3555
<http://www.kyoceramita.com>

©2003, 2004 KYOCERA MITA Corporation

 is a trademark of Kyocera Corporation

Revision 1.3 2004. 2

Free Manuals Download Website

<http://myh66.com>

<http://usermanuals.us>

<http://www.somanuals.com>

<http://www.4manuals.cc>

<http://www.manual-lib.com>

<http://www.404manual.com>

<http://www.luxmanual.com>

<http://aubethermostatmanual.com>

Golf course search by state

<http://golfingnear.com>

Email search by domain

<http://emailbydomain.com>

Auto manuals search

<http://auto.somanuals.com>

TV manuals search

<http://tv.somanuals.com>