FS-C8100DN

Operation Guide



Contents

1	Machine Parts	1-1
	Components at the Front of the Printer	1-2
	Components at the Left of the Printer	1-2
	Components at the Right of the Printer	1-3
	Internal Components	1-4
2	Printing Operation	2-1
	Loading Printer Driver	2-2
	Printing from Application Software	2-3
3	Maintenance	3-1
	General Information	3-2
	Loading Paper	3-3
	Toner Container Replacement	3-8
	Cleaning the Printer	3-13
4	Troubleshooting	4-1
	General Guidelines	4-2
	Print Quality Problems	4-3
	Error Messages	4-6
	Clearing Paper Jams	4-11
5	Specifications	5-1



Legal and Safety Information

CAUTION: NO LIABILITY IS ASSUMED FOR ANY DAMAGE CAUSED BY IMPROPER INSTALLATION.

Notice on Software

SOFTWARE USED WITH THIS PRINTER MUST SUPPORT THE PRINTER'S EMULATION MODE. The printer is factory-set to emulate the PCL. The emulation mode can be changed.

Notice

The information in this guide is subject to change without notification. Additional pages may be inserted in future editions. The user is asked to excuse any technical inaccuracies or typographical errors in the present edition.

No responsibility is assumed if accidents occur while the user is following the instructions in this guide. No responsibility is assumed for defects in the printer's firmware (contents of its read-only memory).

This guide, any copyrightable subject matter sold or provided with or in connection with the sale of the page printer, are protected by copyright. All rights are reserved. Copying or other reproduction of all or part of this guide, any copyrightable subject matter without the prior written consent of Kyocera Mita Corporation is prohibited. Any copies made of all or part of this guide, any copyrightable subject must contain the same copyright notice as the material from which the copying is done.

Regarding Tradenames

PRESCRIBE is a registered trademark of Kyocera Corporation. KPDL is trademark of Kyocera Corporation.

Hewlett-Packard, PCL, and PJI are registered trademarks of Hewlett-Packard Company. Centronics is a trade name of Centronics Data Computer Inc. PostScript is a registered trademark of Adobe Systems Incorporated. Macintosh is a registered trademark of Apple Computer, Inc. Microsoft, Windows, and Windows NT are registered trademarks of Microsoft Corporation. Microsoft Windows Server is a trademark of Microsoft Corporation. PowerPC is a trademark of International Business Machines Corporation. Microdrive is a registered trademark of Hitachi Global Storage Technologies Netherlands B.V. in the US and other countries. CompactFlash is a trademark of SanDisk Corporation. ENERGY STAR is a U.S. registered mark. All other brand and product names are registered trademarks or trademarks of their respective companies.

This product uses PeerlessPrintXL to provide the HP LaserJet compatible PCL 6 language emulation. PeerlessPrintXL is a trademark of Peerless Systems Corporation, 2381 Rosecrans Ave. El Segundo, CA 90245, U.S.A.

This product was developed using the Tornado™ Real Time Operating System and Tools from Wind River Systems.

This product contains UFST™ and MicroType® from Monotype Imaging Inc.

USB



This product has been certified by the USB Implementers Forum, Inc.

License Agreements

IBM Program License Agreement

THE DEVICE YOU HAVE PURCHASED CONTAINS ONE OR MORE SOFTWARE PROGRAMS (“PROGRAMS”) WHICH BELONG TO INTERNATIONAL BUSINESS MACHINES CORPORATION (“IBM”). THIS DOCUMENT DEFINES THE TERMS AND CONDITIONS UNDER WHICH THE SOFTWARE IS BEING LICENSED TO YOU BY IBM. IF YOU DO NOT AGREE WITH THE TERMS AND CONDITIONS OF THIS LICENSE, THEN WITHIN 14 DAYS AFTER YOUR ACQUISITION OF THE DEVICE YOU MAY RETURN THE DEVICE FOR A FULL REFUND. IF YOU DO NOT SO RETURN THE DEVICE WITHIN THE 14 DAYS, THEN YOU WILL BE ASSUMED TO HAVE AGREED TO THESE TERMS AND CONDITIONS.

The Programs are licensed not sold. IBM, or the applicable IBM country organization, grants you a license for the Programs only in the country where you acquired the Programs. You obtain no rights other than those granted you under this license.

The term “Programs” means the original and all whole or partial copies of it, including modified copies or portions merged into other programs. IBM retains title to the Programs. IBM owns, or has licensed from the owner, copyrights in the Programs.

1. License

Under this license, you may use the Programs only with the device on which they are installed and transfer possession of the Programs and the device to another party.

If you transfer the Programs, you must transfer a copy of this license and any other documentation to the other party. Your license is then terminated. The other party agrees to these terms and conditions by its first use of the Program.

You may not:

- 1 use, copy, modify, merge, or transfer copies of the Program except as provided in this license;
- 2 reverse assemble or reverse compile the Program; or
- 3 sublicense, rent, lease, or assign the Program.

2. Limited Warranty

The Programs are provided “AS IS.”

THERE ARE NO OTHER WARRANTIES COVERING THE PROGRAMS (OR CONDITIONS), EXPRESS OR IMPLIED, INCLUDING, BUT NOT LIMITED TO, THE IMPLIED WARRANTIES OF MERCHANTABILITY AND FITNESS FOR A PARTICULAR PURPOSE.

Some jurisdictions do not allow the exclusion of implied warranties, so the above exclusion may not apply to you.

3. Limitation of Remedies

IBM's entire liability under this license is the following;

For any claim (including fundamental breach), in any form, related in any way to this license, IBM's liability will be for actual damages only and will be limited to the greater of:

- 1 the equivalent of U.S. \$25,000 in your local currency; or
- 2 IBM's then generally available license fee for the Program

This limitation will not apply to claims for bodily injury or damages to real or tangible personal property for which IBM is legally liable.

IBM will not be liable for any lost profits, lost savings, or any incidental damages or other economic consequential damages, even if IBM, or its authorized supplier, has been advised of the possibility of such damages. IBM will not be liable for any damages claimed by you based on any third party claim. This limitation of remedies also applies to any developer of Programs supplied to IBM. IBM's and the developer's limitations of remedies are not cumulative. Such developer is an intended beneficiary of this Section. Some jurisdictions do not allow these limitations or exclusions, so they may not apply to you.

4. General

You may terminate your license at any time. IBM may terminate your license if you fail to comply with the terms and conditions of this license. In either event, you must destroy all your copies of the Program. You are responsible for payment of any taxes, including personal property taxes, resulting from this license. Neither party may bring an action, regardless of form, more than two years after the cause of action arose. If you acquired the Program in the United States, this license is governed by the laws of the State of New York. If you acquired the Program in Canada, this license is governed by the laws of the Province of Ontario. Otherwise, this license is governed by the laws of the country in which you acquired the Program.

Typeface Trademark Acknowledgement

All resident fonts in this printer are licensed from Monotype Imaging Inc.

Helvetica, Palatino and Times are registered trademarks of Linotype-Hell AG. ITC Avant Garde Gothic, ITC Bookman, ITC ZapfChancery and ITC Zapf Dingbats are registered trademarks of International Typeface Corporation.

Monotype Imaging License Agreement

- 1** "Software" shall mean the digitally encoded, machine readable, scalable outline data as encoded in a special format as well as the UFST Software.
- 2** You agree to accept a non-exclusive license to use the Software to reproduce and display weights, styles and versions of letters, numerals, characters and symbols ("Typefaces") solely for your own customary business or personal purposes at the address stated on the registration card you return to Monotype Imaging. Under the terms of this License Agreement, you have the right to use the Fonts on up to three printers. If you need to have access to the fonts on more than three printers, you need to acquire a multi-user license agreement which can be obtained from Monotype Imaging. Monotype Imaging retains all rights, title and interest to the Software and Typefaces and no rights are granted to you other than a License to use the Software on the terms expressly set forth in this Agreement.
- 3** To protect proprietary rights of Monotype Imaging, you agree to maintain the Software and other proprietary information concerning the Typefaces in strict confidence and to establish reasonable procedures regulating access to and use of the Software and Typefaces.
- 4** You agree not to duplicate or copy the Software or Typefaces, except that you may make one backup copy. You agree that any such copy shall contain the same proprietary notices as those appearing on the original.
- 5** This License shall continue until the last use of the Software and Typefaces, unless sooner terminated. This License may be terminated by Monotype Imaging if you fail to comply with the terms of this License and such failure is not remedied within thirty (30) days after notice from Monotype Imaging. When this License expires or is terminated, you shall either return to Monotype Imaging or destroy all copies of the Software and Typefaces and documentation as requested.
- 6** You agree that you will not modify, alter, disassemble, decrypt, reverse engineer or decompile the Software.

-
- 7 Monotype Imaging warrants that for ninety (90) days after delivery, the Software will perform in accordance with Monotype Imaging-published specifications, and the diskette will be free from defects in material and workmanship. Monotype Imaging does not warrant that the Software is free from all bugs, errors and omissions.
 - 8 THE PARTIES AGREE THAT ALL OTHER WARRANTIES, EXPRESSED OR IMPLIED, INCLUDING WARRANTIES OF FITNESS FOR A PARTICULAR PURPOSE AND MERCHANTABILITY, ARE EXCLUDED.
 - 9 Your exclusive remedy and the sole liability of Monotype Imaging in connection with the Software and Typefaces is repair or replacement of defective parts, upon their return to Monotype Imaging.
 - 10 IN NO EVENT WILL MONOTYPE IMAGING BE LIABLE FOR LOST PROFITS, LOST DATA, OR ANY OTHER INCIDENTAL OR CONSEQUENTIAL DAMAGES, OR ANY DAMAGES CAUSED BY ABUSE OR MISAPPLICATION OF THE SOFTWARE AND TYPEFACES.
 - 11 Massachusetts U.S.A. law governs this Agreement.
 - 12 You shall not sublicense, sell, lease, or otherwise transfer the Software and/or Typefaces without the prior written consent of Monotype Imaging.
 - 13 Use, duplication or disclosure by the Government is subject to restrictions as set forth in the Rights in Technical Data and Computer Software clause at FAR 252-227-7013, subdivision (b)(3)(ii) or subparagraph (c)(1)(ii), as appropriate. Further use, duplication or disclosure is subject to restrictions applicable to restricted rights software as set forth in FAR 52.227-19 (c)(2).
 - 14 YOU ACKNOWLEDGE THAT YOU HAVE READ THIS AGREEMENT, UNDERSTAND IT, AND AGREE TO BE BOUND BY ITS TERMS AND CONDITIONS. NEITHER PARTY SHALL BE BOUND BY ANY STATEMENT OR REPRESENTATION NOT CONTAINED IN THIS AGREEMENT. NO CHANGE IN THIS AGREEMENT IS EFFECTIVE UNLESS WRITTEN AND SIGNED BY PROPERLY AUTHORIZED REPRESENTATIVES OF EACH PARTY. BY OPENING THIS DISKETTE PACKAGE, YOU AGREE TO ACCEPT THE TERMS AND CONDITIONS OF THIS AGREEMENT.

Compliance and Conformity

FCC Statement (for users in the United States)

This device complies with Part 15 of FCC Rules and RSS-Gen of IC Rules.

Operation is subject to the following two conditions; (1) this device may not cause interference, and (2) this device must accept any interference, including interference that may cause undesired operation of the device.

This equipment has been tested and found to comply with the limits for a Class B digital device, pursuant to part 15 of the FCC Rules. These limits are designed to provide reasonable protection against harmful interference in a residential installation.

This equipment generates, uses and can radiate radio frequency energy and, if not installed and used in accordance with the instructions, may cause harmful interference to radio communications. However, there is no guarantee that interference will not occur in a particular installation. If this equipment does cause harmful interference to radio or television reception, which can be determined by turning the equipment off and on, the user is encouraged to try to correct the interference by one or more of the following measures:

- Reorient or relocate the receiving antenna.
- Increase the distance between the equipment and the receiver.
- Connect the equipment into an outlet on a circuit different from that used for the receiver.
- Consult your service technician or an experienced radio/TV technician for help.

Changes or modifications not expressly approved by the manufacturer for compliance could void the user's authority to operate the equipment. Shielded circular cables should be used for interfacing with the computer.

Precautions for Use

Any modifications without prior permission of Kyocera Mita may cause harmful interference.

If any modifications or changes are made to this equipment without prior permission of Kyocera Mita, Kyocera Mita as the manufacturer does not guarantee the compliance with the FCC Rules. The use of equipment that does not comply with the FCC Rules is prohibited.

Safety Information

Laser Safety

This printer is certified as a Class 1 laser product under the U.S. Department of Health and Human Services (DHHS) Radiation Performance Standard according to Radiation Control for Health and Safety Act of 1968. This means that the printer does not produce hazardous laser radiation. Since radiation emitted inside the printer is completely confined within protective housings and external covers, the laser beam cannot escape from the printer during any phase of user operation.

Laser Notice

This printer is certified in the U.S. to conform to the requirements of DHHS 21 CFR Subchapter for Class I (1) laser products, and elsewhere is certified as a Class I laser product conforming to the requirements of IEC 825.

DANGER: CLASS 3B LASER RADIATION WHEN OPEN. AVOID DIRECT EXPOSURE TO BEAM.

CAUTION: Use of controls or adjustments or performance of procedures other than those specified herein may result in hazardous radiation exposure.

Radio Frequency Transmitter

This machine contains the transmitter module. We, the manufacturer (Kyocera Mita Corporation) hereby declare that this equipment (page printer), model FS-C8100DN is in compliance with the essential requirements and other relevant provisions of Directive 1999/5/EC.

Radio Tag Technology

In some countries the radio tag technology used in this equipment to identify the toner container may be subject to authorization and the use of this equipment may consequently be restricted.

CDRH Regulations

The Center for Devices and Radiological Health (CDRH) of the U.S. Food and Drug Administration implemented regulations for laser products on August 2, 1976. These regulations apply to laser products manufactured after August 1, 1976. Compliance is mandatory for products marketed in the United States. A label indicating compliance with the CDRH regulations must be attached to laser products marketed in the United States. On this machine, the label is on the right.

Ozone Concentration

The printers generate ozone gas (O₃) which may concentrate in the place of installation and cause an unpleasant smell. To minimize the concentration of ozone gas to less than 0.1 ppm, we recommend you not to install the printer in a confined area where ventilation is blocked.

Declaration of Conformity for U.S.A.

Model name: Color Page Printer FS-C8100DN
Trade name: Kyocera Mita
Responsible party: Kyocera Mita America, Inc.
Address: 225 Sand Road PO Box 40008 Fairfield, New Jersey 07004-0008, U.S.A.
Telephone: (973) 808-8444
Fax: (973) 882-6000

Manufacturer: Kyocera Mita Corporation
Manufacturer's address: 2-28, 1-Chome, Tamatsukuri, Chuo-ku, Osaka, 540-8585, Japan

This device complies with Part 15 of the FCC Rules. Operation is subject to the following two conditions: (1) this device may not cause harmful interference, and (2) this device must accept any interference received, including interference that may cause undesired operation.

The manufacturer and its merchandising companies retain the following technical documentation in anticipation of the inspection that may be conducted by the authorities concerned.

User's instruction that conforms to the applicable specifications.
Technical drawings.
Descriptions of the procedures that guarantee the conformity.
Other technical information.

Kyocera Mita America Inc.

CE Marking Directive

According to Council Directive 89/336/EEC, 73/23/EEC, and 1999/5/EC

Manufacturer: Kyocera Mita Corporation
Manufacturer's address: 2-28, 1-Chome, Tamatsukuri, Chuo-ku, Osaka, 540-8585, Japan

Declares that the product

Product name: Color Page Printer

Model number: FS-C8100DN (as tested with enhancement optional unit; Dual Paper Feeder PF-710, Large Capacity Paper Feeder PF-750, Document Finisher DF-710/DF-730, Booklet Unit BF-710, Mail Bin MT-710, and Punch Unit PH-5A)

Conforms to the following product specifications:

EN 55 022:1998+A1:2000+A2:2003 Class B
EN 61 000-3-2:2000
EN 61 000-3-3:1995+A1:2001
EN 55 024:1998+A1:2001+A2:2003
EN 60 950-1:2001+A11
EN 60 825-1:1994+A1+A2
EN 300330-1
EN 300330-2

The manufacturer and its merchandising companies retain the following technical documentation in anticipation of the inspection that may be conducted by the authorities concerned.

User's instruction that conforms to the applicable specifications.
Technical drawings.
Descriptions of procedures that guarantee conformity.
Other technical information.

Declaration of Conformity (Australia)

Manufacturer: Kyocera Mita Corporation
Manufacturer's address: 2-28, 1-Chome, Tamatsukuri, Chuo-ku, Osaka, 540-8585, Japan

declares that the product

Product name: Color Page Printer
Model name: FS-C8100DN

Description of devices: This Page Printer Model FS-C8100DN is the 32 ppm; A4 size and utilized plain paper; dry toner; etc. The printer can be equipped with several enhancement optional unit as a dual paper feeder as PF-710, large capacity paper feeder as PF-750, DF-710/DF-730 as document finisher, booklet unit as BF-710m mail bin as MT-710, and punch unit as PH-5A.

conforms to the following product specifications:

AS/NZS 3548: 1995 (EN 55 022: 1998 Class B)
AS/NZS 4268: 2003
IEC60950: 1999 (EN 60 950: 2000)

The manufacturer and its merchandising companies retain the following technical documentation in anticipation of the inspection that may be conducted by the authorities concerned.

User's instruction that conforms to the applicable specifications
Technical drawings
Descriptions of procedures that guarantee conformity
Other technical information

The manufacturer has been employed with ISO9001 scheme. JQA and BS have attested the manufacturer.

Kyocera Mita Australia Pty., Ltd.
6-10 Talavera Road, North Ryde, NSW 2113, Australia
Telephone: +61 2-9888-9999
Fax: +61 2-9888-9588

Canadian Department of Communications Compliance Statement

This Class B digital apparatus complies with Canadian ICES-003.

Avis de conformité aux normes du ministère des Communications du Canada

Cet appareil numérique de la classe B est conforme à la norme NMB-003 du Canada.

EN ISO 7779

Maschinenlärminformations-Verordnung 3. GPSGV, der höchste Schalldruckpegel beträgt 70 dB (A) oder weniger gemäß EN ISO 7779.

Disclaimer

Kyocera Mita will not be liable to customers or any other person or entity for any loss or damage caused or alleged to be caused directly or indirectly by equipment sold or furnished by us, including but not limited to, any interruption of service, loss of business or anticipatory profits, or consequential damages resulting from the use or operation of the equipment or software.

Energy Star Program



As an ENERGY STAR Partner, we have determined that this product meets the ENERGY STAR guidelines for energy efficiency.

The basic objective of the ENERGY STAR Program is to reduce environmental pollution by encouraging the manufacture and sale of equipment that uses energy more efficiently.

This printer is equipped with a sleep timer function that conforms with the standards of the ENERGY STAR Program. This function makes it possible to reduce the amount of electrical power consumed by the printer. For maximum power savings, turn off the printer's power supply when not using the printer for extended periods of time.

For details on the sleep timer function and printer power consumption, refer to this manual.

Initial settings of the sleep timer function and power saved using the sleep timer function:

Initial Auto Sleep Setting	15 minutes (60 minutes)
Power Consumption in Auto Sleep	15 W (70 W)

(): ENERGY STAR program guideline

Group for Energy Efficient Appliances (GEEA)



The goal of GEEA is efficient use of energy. This product has a high-efficiency profile and meets the criteria for receiving the GEEA-Label.

Initial Auto Sleep Setting	15 minutes (30 minutes)	
Power Consumption	Power off	1 W (1 W)
	Auto Sleep	15 W (30 W)

(): GEEA criteria

Please read this Operation Guide before using the machine. Keep it close to the machine for easy reference.

The sections of this guide and parts of the machine marked with symbols are safety warnings meant to protect the user, other individuals and surrounding objects, and ensure correct and safe usage of the machine. The symbols and their meanings are indicated below.



DANGER: Indicates that serious injury or even death will very possibly result from insufficient attention to or incorrect compliance with the related points.



WARNING: Indicates that serious injury or even death may result from insufficient attention to or incorrect compliance with the related points.



CAUTION: Indicates that personal injury or mechanical damage may result from insufficient attention to or incorrect compliance with the related points.

Symbols

The following symbols indicate that the related section includes safety warnings. Specific points of attention are indicated inside the symbol.



.... [General warning]



.... [Warning of danger of electrical shock]



.... [Warning of high temperature]

The following symbols indicate that the related section includes information on prohibited actions. Specifics of the prohibited action are indicated inside the symbol.



.... [Warning of prohibited action]



.... [Disassembly prohibited]

The following symbols indicate that the related section includes information on actions which must be performed. Specifics of the required action are indicated inside the symbol.



.... [Alert of required action]



.... [Remove the power plug from the outlet]



.... [Always connect the machine to an outlet with a ground connection]

Please contact your service representative to order a replacement if the safety warnings in this Operation Guide are illegible or if the guide itself is missing. (fee required)



Installation Precautions

Environment



CAUTION:

Avoid placing the machine on or in locations which are unstable or not level. Such locations may cause the machine to fall down or fall over. This type of situation presents a danger of personal injury or damage to the machine.

Avoid locations with humidity or dust and dirt. If dust or dirt become attached to the power plug, clean the plug to avoid the danger of fire or electrical shock.

Avoid locations near radiators, heaters, or other heat sources, or locations near flammable items, to avoid the danger of fire.

To keep the machine cool and facilitate changing of parts and maintenance, allow access space as shown below. Leave adequate space, especially around the vents, to allow air to be properly ventilated out of the printer.

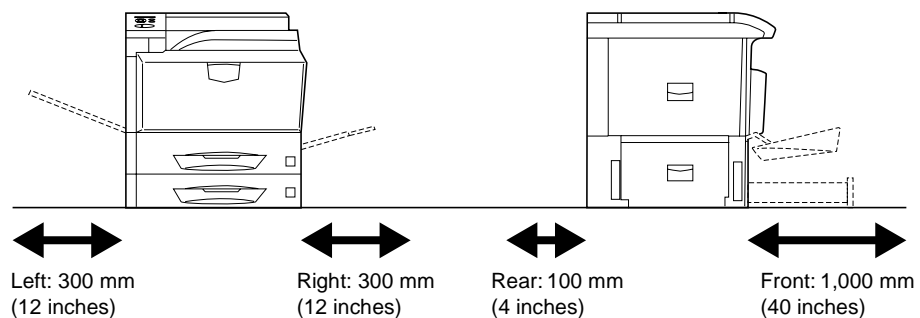
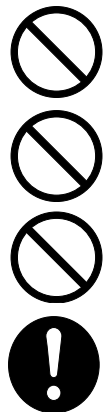

Other Precautions

The service environmental conditions are as follows:

- Temperature: 10 to 32.5 °C (50 to 90.5 °F), but humidity should be 70 % or less when temperature is 32.5 °C (90.5 °F)
- Humidity: 15 to 80 %, but temperature should be 30 °C or less (86 °F or less) when humidity is 80%

However, adverse environmental conditions may affect the image quality. It is recommended to use the machine at a temperature: around 16 to 27 °C (60.8 to 80.6 °F), humidity: around 36 to 65 %. In addition, avoid the following locations when selecting a site for the machine.

- Avoid locations near a window or with exposure to direct sunlight.
- Avoid locations with vibrations.
- Avoid locations with drastic temperature fluctuations.
- Avoid locations with direct exposure to hot or cold air.
- Avoid poorly ventilated locations.

During printing, small amounts of ozone and other chemicals are released, but the amount does not cause any ill effect to one's health. If, however, the printer is used over a long period of time in a poorly ventilated room or when printing an extremely large number of copies, the smell may become unpleasant. To maintain the appropriate environment for print work, it is suggested that the room be properly ventilated.

Power Supply/Grounding the Machine



WARNING:

Do not use a power supply with a voltage other than that specified. Avoid multiple connections in the same outlet. These types of situations present a danger of fire or electrical shock.

Plug the power cord securely into the outlet. If metallic objects come in contact with the prongs on the plug, it may cause a fire or electric shock.

Always connect the machine to an outlet with a ground connection to avoid the danger of fire or electrical shock in case of an electric short. If an earth connection is not possible, contact your service representative.



Other Precautions

Connect the power plug to the closest outlet possible to the machine. The power supply cord is used as the main disconnect device. Ensure that the socket/outlet is located/installed near the equipment and is easily accessible.

Handling of Plastic Bags



WARNING:

Keep the plastic bags that are used with the machine away from children. The plastic may cling to their nose and mouth causing suffocation.





Precautions for Use

Cautions when Using the Machine



WARNING:

Do not place metallic objects or containers with water (flower vases, flower pots, cups, etc.) on or near the machine. This situation presents a danger of fire or electrical shock should they fall inside.

Do not remove any of the covers from the machine as there is a danger of electrical shock from high voltage parts inside the machine.

Do not damage, break or attempt to repair the power cord. Do not place heavy objects on the cord, pull it, bend it unnecessarily or cause any other type of damage. These types of situations present a danger of fire or electrical shock.

Never attempt to repair or disassemble the machine or its parts as there is a danger of fire, electrical shock or damage to the laser. If the laser beam escapes, there is a danger of it causing blindness.

If the machine becomes excessively hot, smoke appears from the machine, there is an odd smell, or any other abnormal situation occurs, there is a danger of fire or electrical shock. Turn the power switch off (O) immediately, be absolutely certain to remove the power plug from the outlet and then contact your service representative.

If anything harmful (paper clips, water, other fluids, etc.) falls into the machine, turn the power switch off (O) immediately. Next, be absolutely certain to remove the power plug from the outlet to avoid the danger of fire or electrical shock. Then contact your service representative.

Do not remove or connect the power plug with wet hands, as there is a danger of electrical shock.

Always contact your service representative for maintenance or repair of internal parts.



CAUTION

Do not pull the power cord when removing it from the outlet. If the power cord is pulled, the wires may become broken and there is a danger of fire or electrical shock. (Always grasp the power plug when removing the power cord from the outlet.)

Always remove the power plug from the outlet when moving the machine. If the power cord is damaged, there is a danger of fire or electrical shock.

If the machine will not be used for a short period of time (overnight, etc.), turn the power switch off (O). If it will not be used for an extended period of time (vacations, etc.), remove the power plug from the outlet for safety purposes during the time the machine is not in use.



When moving the machine, pull out two carrying handles on the left side, and move with carrying handles and the having hand two place of the right side.

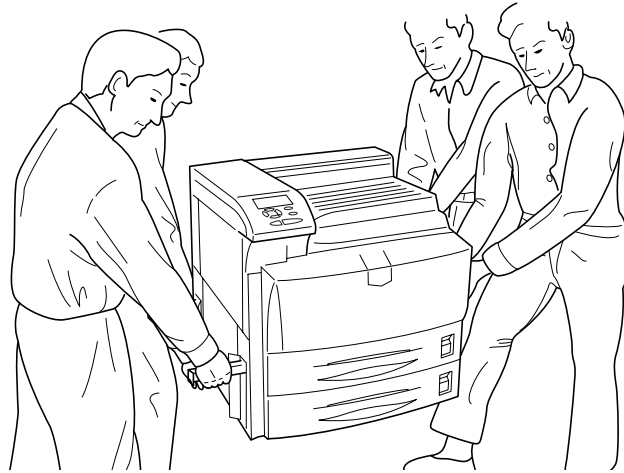

For safety purposes, always remove the power plug from the outlet when performing cleaning operations.



If dust accumulates within the machine, there is a danger of fire or other trouble. It is therefore recommended that you consult with your service representative in regard to cleaning of internal parts. This is particularly effective if accomplished prior to seasons of high humidity. Consult with your service representative in regard to the cost of cleaning the internal parts of the machine.



Other Precautions

Do not place heavy objects on the machine or cause other damage to the machine.

Do not open the upper front cover, turn off the power switch, or pull out the power plug during printing.

When lifting or moving the machine, contact your service representative.

Do not touch electrical parts, such as connectors or printed circuit boards. They could be damaged by static electricity.

Do not attempt to perform any operations not explained in this handbook.

Use shielded interface cables.



CAUTION

Use of controls or adjustments or performance of procedures other than those specified herein may result in hazardous radiation exposure.

Cautions when Handling Consumables



CAUTION

Do not attempt to incinerate the Toner Container. Dangerous sparks may cause burns.



Keep the Toner Container out of the reach of children.



If toner happens to spill from the Toner Container, avoid inhalation and ingestion, as well as contact with your eyes and skin.



- If you do happen to inhale toner, move to a place with fresh air and gargle thoroughly with a large amount of water. If coughing develops, contact a physician.
- If you do happen to ingest toner, rinse your mouth out with water and drink 1 or 2 cups of water to dilute the contents of your stomach. If necessary, contact a physician.
- If you do happen to get toner in your eyes, flush them thoroughly with water. If there is any remaining tenderness, contact a physician.
- If toner does happen to get on your skin, wash with soap and water.

Do not attempt to force open or destroy the Toner Container.



Other Precautions

After use, always dispose of the Toner Container in accordance with Federal, State and Local rules and regulations.

Store all consumables in a cool, dark location.

If the machine will not be used for an extended period of time, remove the paper from the cassette, return it to its original package and reseal it.

About the Operation Guide

This Operation Guide has the following chapters:

1 Machine Parts

This chapter explains the names of parts.

2 Printing Operation

This chapter explains how to print from your PC.

3 Maintenance

This chapter explains how to replace the toner container and how to care for your printer.

4 Troubleshooting

This chapter explains how to handle printer problems that may occur, such as paper jams.

5 Specifications

This chapter lists the printer's specifications.

Conventions

This manual uses the following conventions.

Convention	Description	Example
Italic Typeface	Used to emphasize references to additional information.	Refer to <i>Toner Container Replacement</i> on page 3-3.
Courier Typeface	Used to denote messages or names displayed on the operation panel.	Replace the waste toner box when the <code>Check waste toner box</code> message is displayed.
Bracket Bold Text Typeface	Used to denote operation panel keys.	Press [Menu] .
Bold Typeface	Used to emphasize button or items to be selected in dialog boxes, and titles displaying in dialog boxes.	Click Next .
Note	Used to provide additional or useful information about a function or feature.	NOTE: For information about storing the pin, refer to step 10.
Important	Use to provide important information.	IMPORTANT: Ensure paper is not folded, curled, or damaged.
Caution	Cautions are statements that suggest mechanical damage as a result of an action.	CAUTION: Do not pull the cassette out when holding the front of the machine.
Warning	Used to alert users to the possibility of personal injury.	WARNING: High voltage is present in the charger section.



1 Machine Parts

This section provides explanations and illustrations for you to determine the parts and their functions. Try to be familiar with the names and functions of these parts for correct use and optimal performance.

This chapter contains explanations on the following topics:

- Components at the Front of the Printer...1-2
- Components at the Left of the Printer...1-2
- Components at the Right of the Printer...1-3
- Internal Components...1-4

Components at the Front of the Printer

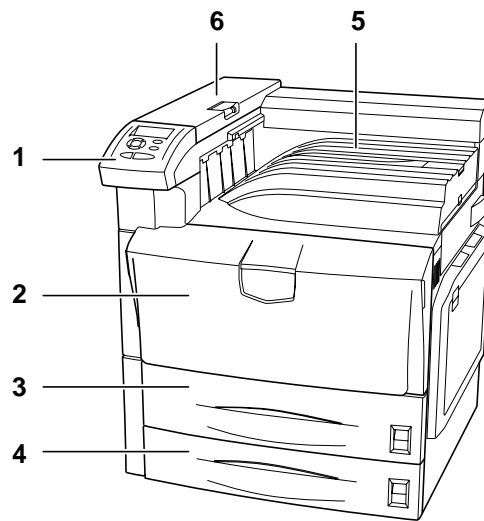

- 1 Operation Panel
- 2 Front Cover
- 3 Paper Cassette 1
- 4 Paper Cassette 2
- 5 Top Tray
- 6 Top Cover

Components at the Left of the Printer

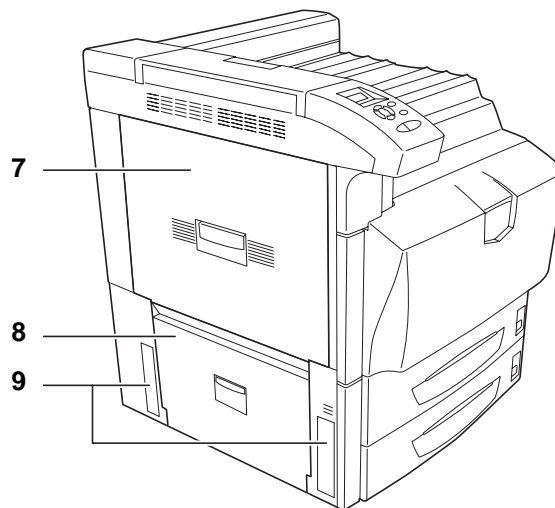

- 7 Left Cover 1
- 8 Left Cover 2
- 9 Carrying Handles

Components at the Right of the Printer

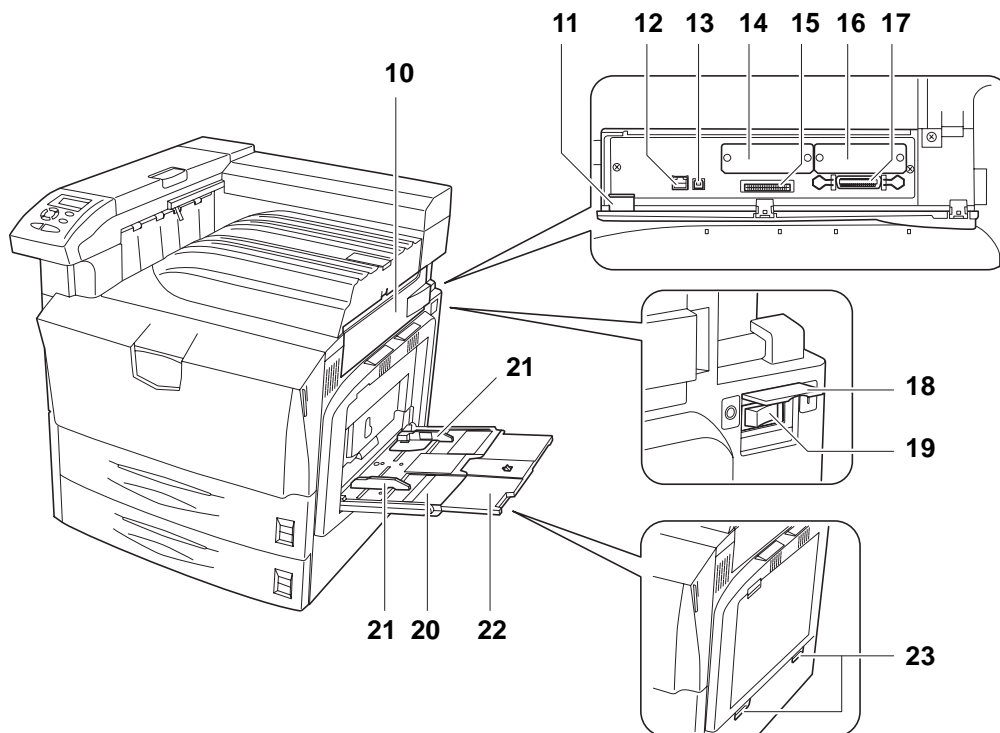

- 10** Interface Cover
- 11** Memory Card (CompactFlash) Cover
- 12** Network Interface Connector
- 13** USB Interface Connector
- 14** Option Interface Slot (OPT)
- 15** Memory Card (CompactFlash) Slot
- 16** Option Hard Disk Unit Slot (HDD)
- 17** Parallel Port Interface Connector
- 18** Main Power Switch Cover
- 19** Main Power Switch
- 20** MP Tray (multi-purpose tray)
- 21** Slider
- 22** MP Tray Extension
- 23** Hand Holes

Internal Components

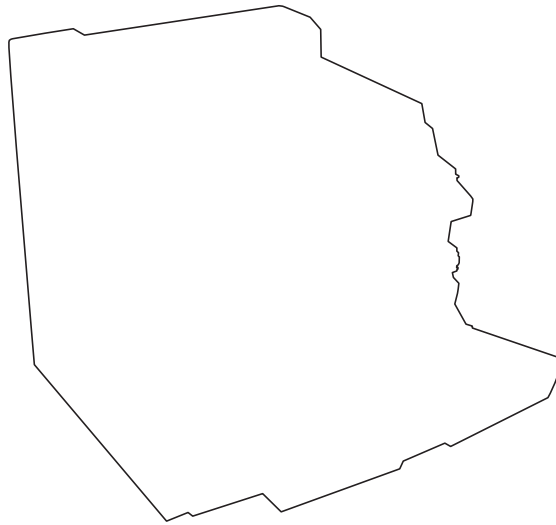

- 24** Toner Container (Black)
- 25** Toner Container (Yellow)
- 26** Toner Container (Cyan)
- 27** Toner Container (Magenta)
- 28** Waste Toner Box
- 29** Toner Container Lock Lever
- 30** Cleaning Brush

- 31** Paper Width Guide
- 32** Paper Width Adjusting Tab
- 33** Paper Length Guide
- 34** Power Cord Connector

2 Printing Operation

This chapter contains explanations on the following topics:

- Loading Printer Driver...2-2
- Printing from Application Software...2-3

Loading Printer Driver

Ensure the printer is plugged in and connected to the PC before installing the printer driver from the CD-ROM.

- 1 Switch on the PC and activate Windows.

NOTE: If the **Welcome to the Found New Hardware Wizard** dialog box displays, select **Cancel**.

- 2 Insert the CD-ROM supplied with the printer into the optical drive of the PC.
- 3 The installation program launches.

NOTE: If the installation program fails to launch, use Windows Explorer to access the CD-ROM and select **Setup.exe**.

- 4 Perform the procedures displayed on the installation program to install the KX DRIVER.

Printing from Application Software

The steps required to print a document created with an application are explained below. You can select the printing **Paper Size** and **Output Destination**.

- 1 Load the paper required into the paper cassette.
- 2 From the application **File** menu, select **Print**. The **Print** dialog box displays.
- 3 Click the drop down list of printer names. All the printers installed in Windows are listed. Click the name of the machine.
- 4 Use **Number of copies** to enter the number of prints required. Up to 999 copies can be entered.
For Microsoft Word, we recommend that you click **Options** and specify **Use printer settings** for the **Default tray**.

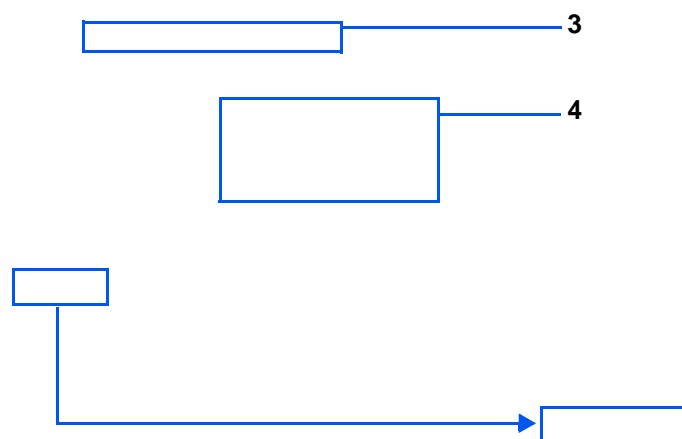

- 5 To start printing, click **OK**.

NOTE: For information on how to use the printer driver software, refer to the *KX Printer Driver Operation Guide*.

3 Maintenance

This chapter contains explanations on the following topics:

- General Information...3-2
- Loading Paper...3-3
- Toner Container Replacement...3-8
- Cleaning the Printer...3-13

General Information

This chapter describes basic maintenance tasks you can perform on the printer.

You can replace the following component according to the printer's display:

- Toner Kits
- Waste Toner Box

Also, the internal parts need periodic cleaning.

Loading Paper

The following explains the procedure for loading paper in the cassette and the MP tray.

Loading Paper into the Cassette

Plain paper (80 g/m²) can be loaded in the paper cassette 1 and 2.

500 sheets (A4/Letter or smaller) or 250 sheets (B4/Legal or larger) can be loaded in the paper cassette 1. 500 sheets can be loaded in the paper cassette 2.

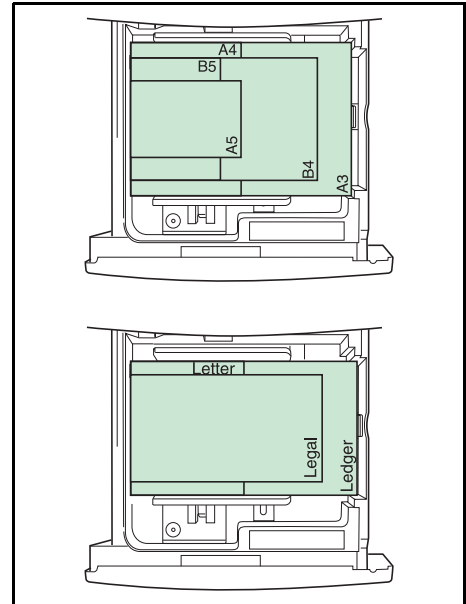

Fan the paper, then tap it on a level surface to avoid media jams or skewed printing.

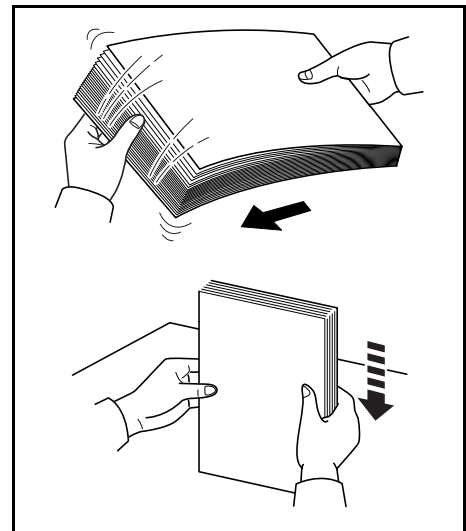

Load paper on the paper cassette following the instructions below.

- 1 Pull out the paper cassette completely.

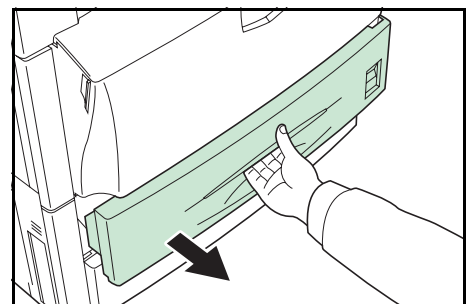

- 2 Set the paper length guide to the selected paper size.

NOTE: Paper size is printed on the paper cassette.

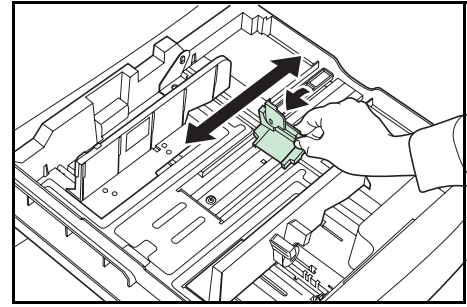

- 3 Set the paper width guide to the selected paper size with the paper width adjusting tab.

NOTE: Paper size is printed on the paper cassette.

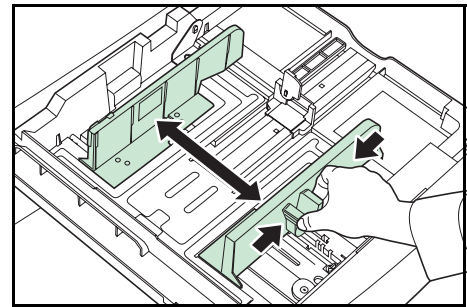

To load paper of A4/letter or smaller, set the supplement lever of the paper length guide upright as illustrated.

- 4 Set paper aligning with the left side of the paper cassette.

IMPORTANT: Confirm that the paper length and paper width guides are lined up closely with paper. If space is found, set the guide again. Otherwise, it may cause paper jams.

Do not set folded paper. Otherwise, it may cause paper jams.

Do not exceed the upper limit of the tray. Otherwise, it may cause paper jams.

- 5 Set the included paper sheet indicating the set paper size.

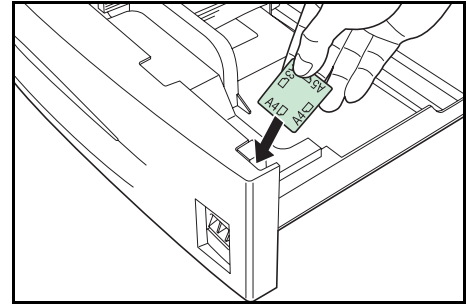

- 6 Slowly set back the paper cassette.

Loading Paper into the MP (Multi-Purpose) Tray

Extra paper (60 - 220 g/m²) as well as plain or recycled paper can be loaded. For plain paper (80 g/m²), 100 sheets (A4/Letter or smaller) or 50 sheets (B4/Legal or larger) can be loaded. Be sure to use the MP tray to print on extra paper such as OHP film or thick paper.

IMPORTANT: When setting special paper, such as transparencies and thick paper, into the MP tray, select the type of paper by referring to *Paper Type* in the *Handling Paper of the Advanced Operation Guide*.

Follow the instructions below to use the MP tray.

- 1 Prepare the MP tray.

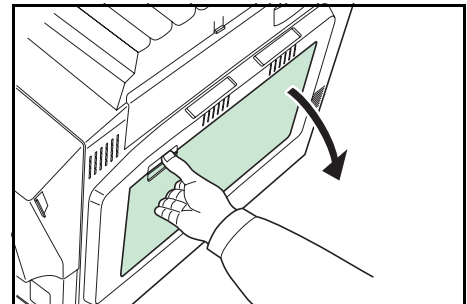

Extend the MP tray to load paper of A4R or larger.

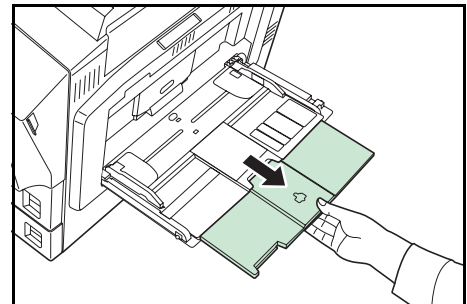

- 2 Set the slider to the width of paper to be used.

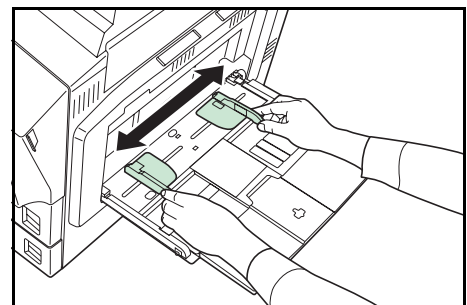

- 3 Set paper along the slider, and insert it until it stops.
Be sure the slider touches the edge of paper.

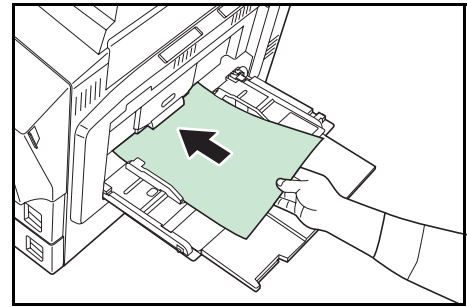

IMPORTANT: If you load a postcard or thick paper, be sure to flatten the paper before setting. Some paper cannot be loaded depending on paper type.

Load paper into the MP tray only when it is in use. Avoid leaving paper in the MP tray.

Do not exceed the upper limit of the tray. Otherwise, it may cause paper jams.

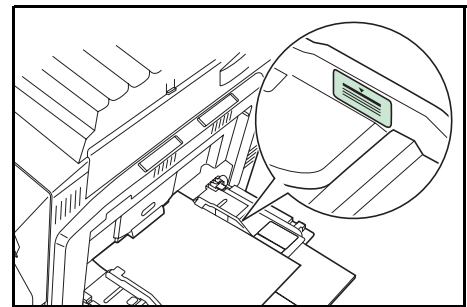

If you set an envelope, be sure to close the opening and set the printing side up. Set the opening front or left, and insert it along the slide until it stops.

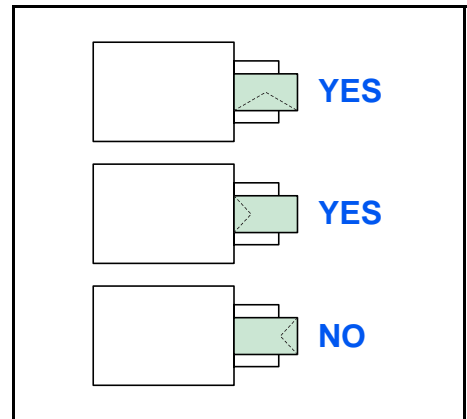

Loading paper into the optional paper feeder PF-750

3000 sheets of plain paper (80 g/m², A4, B5 or Letter) can be loaded into the optional paper feeder PF-750. (Ask your service technician to adjust the size).

Follow the instructions below to load paper into the paper feeder.

- 1 Pull out the paper cassette of the paper feeder completely.

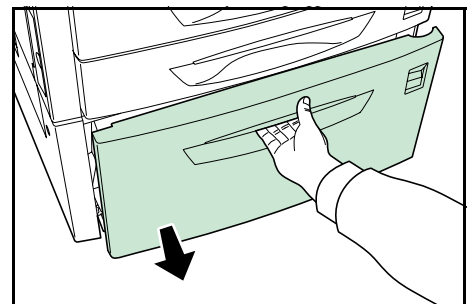

- 2 Set paper into the paper cassette.

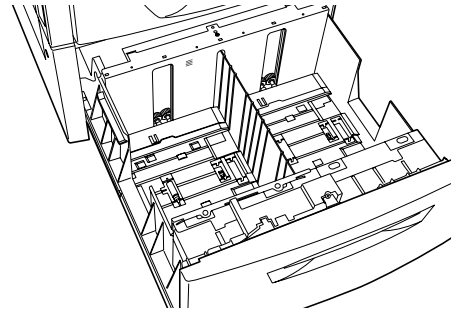

NOTE: Do not set folded paper. Otherwise, it may cause paper jams.

Do not exceed the upper limit of the cassette.

-
- 3 Slowly set back the paper cassette.

Toner Container Replacement

Frequency of toner container replacement

The life of the toner containers depends on the amount of toner required to accomplish your printing jobs. When 5% coverage (a typical business document) of individual toner colors is assumed for A4 or letter size paper:

- The black toner container lasts an average of 15,000 monochrome pages.
- The cyan, magenta, and yellow toner containers last an average of 7,000 color images.

You can print a status page to check how much toner remains in the toner container - refer to *Printing a Status Page* in the *Using the Operation Panel* section of the *Advanced Operation Guide*. The Toner Gauge in the consumables status section on the status page shows a progress bar for each color, which roughly represents how much toner is left in the toner container.

Starter Toner Containers

The toner containers packed with the new printer are starter toner containers. The black starter toner container lasts an average of 7,500 monochrome pages. The cyan, magenta, and yellow starter toner containers last an average of 3,500 color images for each.

Toner Kits

It is strongly recommended that you use the new toner kit supplied from the manufacturer to prevent printer troubles and ensure a long printer life.

The toner kits are supplied in 4 different colors: cyan, magenta, yellow and black.

A new toner kit for each color contains the following items:

- Toner Container
- Cleaning cloth
- Plastic waste bags for old toner container and old waste toner box
- Waste toner box
- Installation Guide

NOTE: Do not remove the toner container from the carton until you are ready to install it in the printer.

Understanding Messages Requesting Toner Container Replacement

The printer displays messages for individual colors at two stages of toner usage. This message is automatically alternated with the other printer message (such as `Ready`):

- When the printer becomes low on toner, for example in the cyan container, the printer displays the message `Toner low C, M, Y, K` as the first caution. Note the replacement is not always necessary at this stage.
- If you ignore the above message and continue printing, the printer displays the message `Replace toner` — just before the toner is used up. The toner container must be replaced immediately. Clean the separate charger wires, etc. After the cleaning is finished, however, the message does not automatically change to `Ready`. To restart printing, you must press **[GO]** and make the printer ready.

In either case, replace the toner container, refer to *Replacing the Toner Container* on page 3-9.

Replacing the Toner Container

This section explains how to replace the toner containers. When replacing the toner container of any color, always replace the waste toner box at the same time. If this box is full, the printer may be damaged or contaminated by the waste toner that may spill out of the box.

NOTE: During toner container replacement, temporarily put storage media and computer supplies (such as floppy disks) away from around the toner container. This is to avoid damaging media by the magnetism of the toner.

You do not have to turn the printer power off before starting the replacement. Any data that may be in the process of printing in the printer will be deleted if you turn the printer power off.

To replace the toner container, first make sure of the color of the toner container requiring replacement. In this example, it is assumed that you are replacing the black toner container.

- 1 Open the front cover.

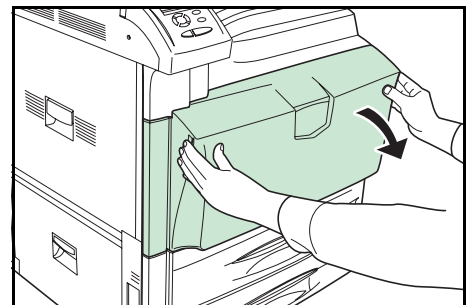

- 2 Turn the toner container lock lever clockwise and set it to the upright position.

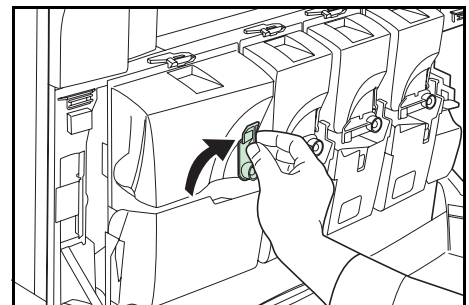

- 3 Push and lift up the clip on the upper part of the toner container (A), and then pull the toner container.

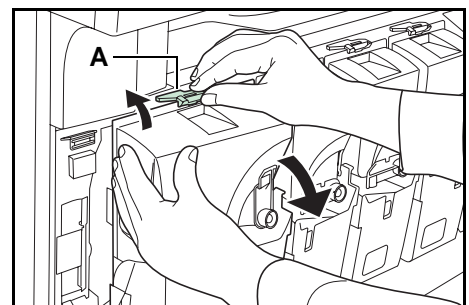

- 4 Remove the toner container.

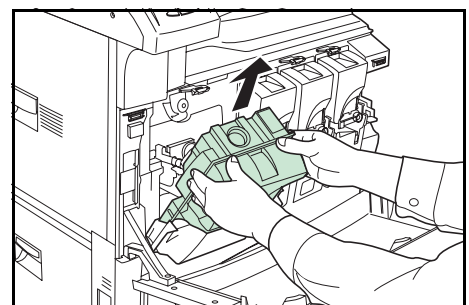

- 5 Cover the toner hole with the cap on the rear side of the container.

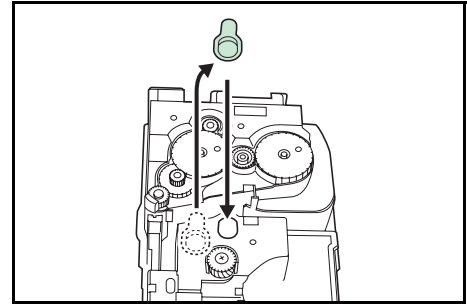

- 6 Insert the container into the plastic bag provided for empty containers.

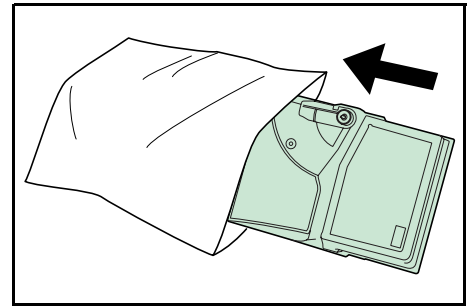

- 7 Remove a new toner container from the carton box.

- 8 Hold the new toner container with the toner container lock lever up, and tap the upper part of the container 10 times or more. Do not tilt the container.

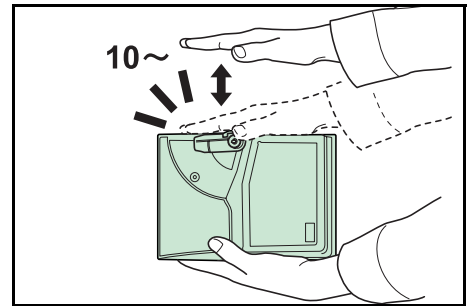

- 9 Hold the toner container with both hands as illustrated, and shake the container strongly 10 times or more.

IMPORTANT: Shake the container fully. Otherwise an error may occur due to short supply of toner.

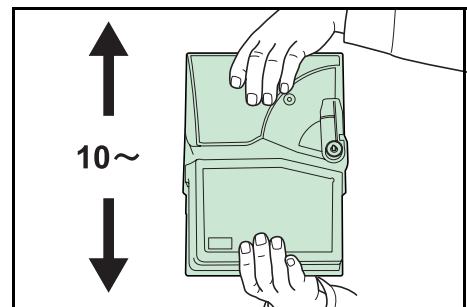

- 10 Set the new toner container into the printer.

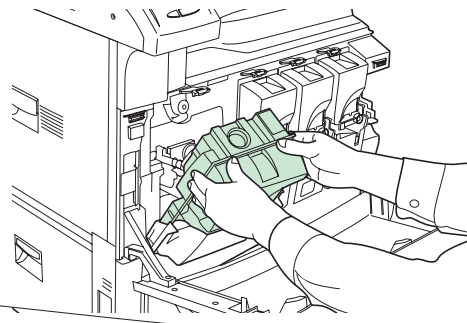

- 11 Be sure to insert the upper part of the container until you hear a clicking sound. When the toner container is correctly set, it will be locked.

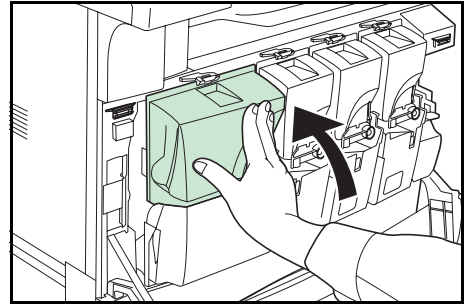

- 12 Set back the toner container lock lever to the original position.
Replace other color toner containers in the same way.

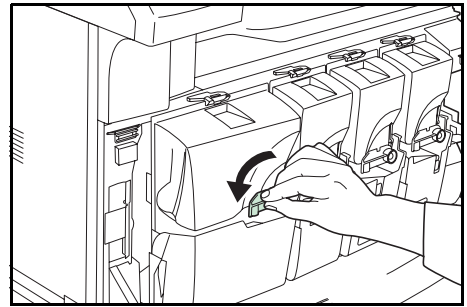

- 13 Press the release lever of the waste toner box (B), and then pull out the waste toner box slowly.

NOTE: Do not place the used waste toner box upside down.

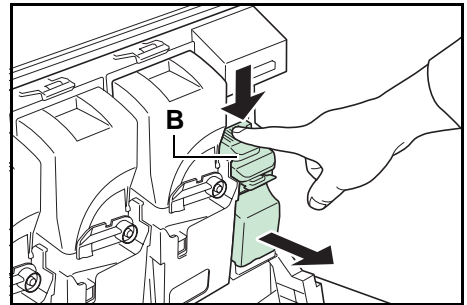

- 14 Place the cap on the used waste toner box as illustrated.

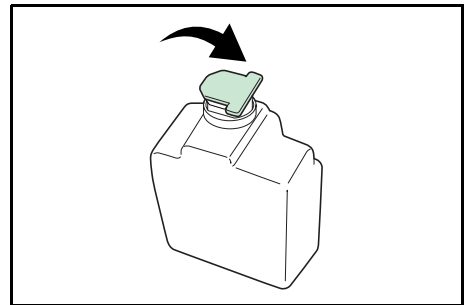

- 15 Insert the used waste toner box into the plastic bag provided for waste toner boxes.

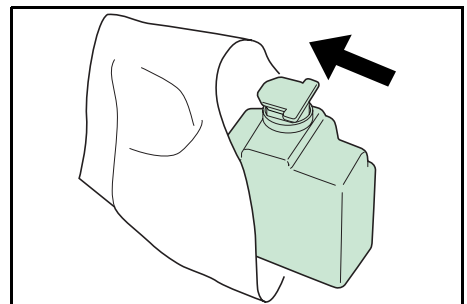

- 16** Open the cap of the new waste toner box.

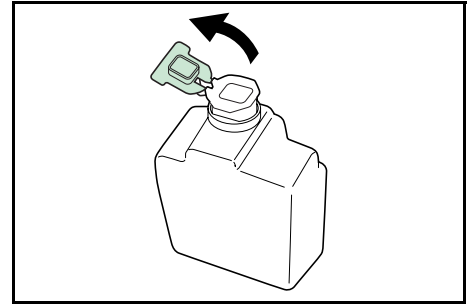

- 17** Set the new waste toner box in the printer.

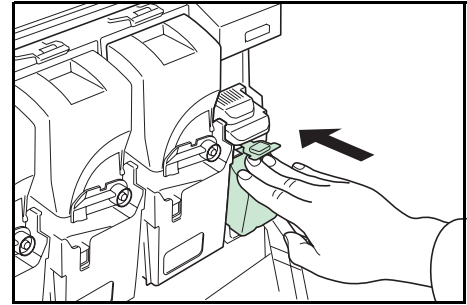

- 18** Close the front cover.

When replacing is finished, clean the printer referring to *Cleaning the Printer* on page 3-13.

Cleaning the Printer

Clean the inside of the printer whenever the toner container or the waste toner box is replaced to maintain the best printing quality.

- 1 Open the front cover.

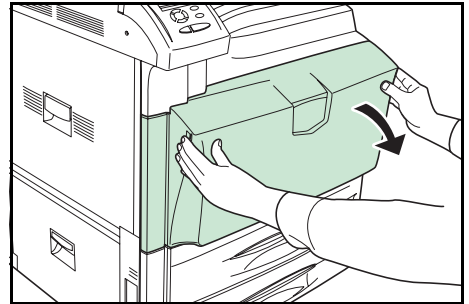

- 2 Remove the cleaning brush.

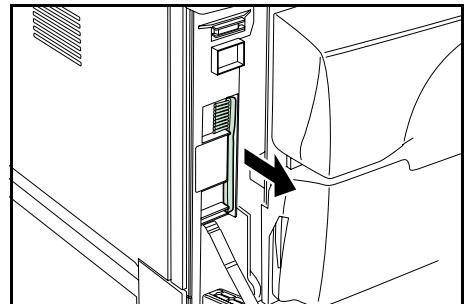

- 3 Open the left cover 1.

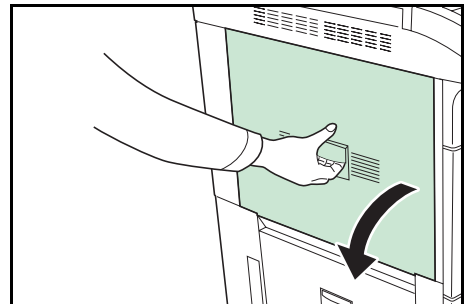

- 4 Open the duplex unit A1.

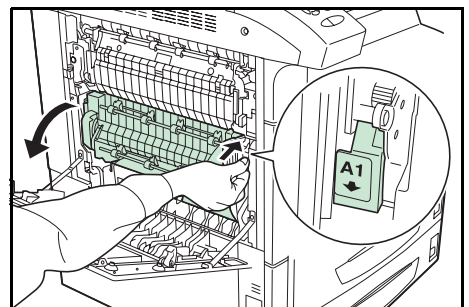

- 5 Move the brush left and right along the separator as illustrated to clean the separator.

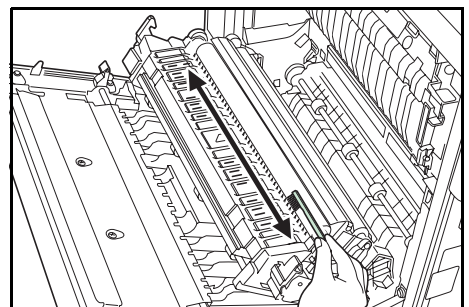

- 6 Close the duplex unit **A1** and the left cover 1.

IMPORTANT: Push the indicated position to close left cover 1 securely.

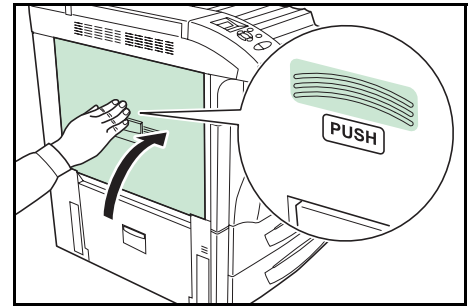

- 7 Replace the clean brush and close the front cover.

4 Troubleshooting

This chapter contains explanations on the following topics:

- General Guidelines...4-2
- Print Quality Problems...4-3
- Error Messages...4-6
- Clearing Paper Jams...4-11

If a problem cannot be corrected, contact your service technician.

General Guidelines

The table below provides basic solutions for problems you may encounter with the printer. We suggest you consult this table to troubleshoot the problems before calling for service.

Symptom	Check Items	Corrective Action
Print quality is not good.	Refer to <i>Print Quality Problems</i> on page 4-3.	
Paper is jammed.	Refer to <i>Clearing Paper Jams</i> on page 4-11.	
Nothing lights on the operation panel even when power is turned on and the fan makes no noise.	Check that the power cord is properly plugged into the power outlet.	Turn off the printer's power, plug in the power cord securely, and try turning on the printer's power again.
	Check that the power switch is in the On (I) position.	Set the power switch to the On position.
The printer prints a status page, but does not print jobs from the computer.	Check the printer cable or the interface cable.	Connect both ends of the printer cable securely. Try replacing the printer cable or the interface cable.
	Check program files and application software.	Try printing another file or using another print command. If the problem occurs only with a specific file or application, check the printer driver settings for that application.

Tips

Printer problems may be solved easily by following the tips below. When you have encountered a problem that following the above guidelines will not solve, try the following:

- Turn the printer power off and wait for several seconds. Then, turn on the printer.
- Reboot the computer which sends the print jobs to the printer.
- Obtain and use the latest version of the printer driver. The latest versions of printer drivers and utilities are available at: <http://www.kyoceramita.com/download/>.
- Make sure that the procedures for printing are correctly followed in the application software. Consult the documentation supplied with the application software.
- If the printer prints strange characters or locks when the computer is turned on, particularly when the printer is connected to a computer using Windows 98 via the parallel port, rename device driver file drvppqt.vxd. This file may be located in Windows\System\losubsys or Arcada\System folder. For technical details, visit Microsoft web site for the device driver.

Print Quality Problems

The tables and diagrams in the following sections define print quality problems and the corrective action you can take to solve the problems. Some solutions may require cleaning or replacing parts of the printer.

If the suggested corrective action will not solve the problem, call for service.

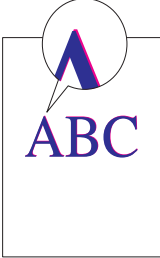
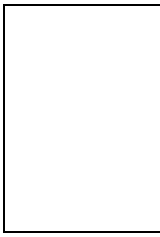
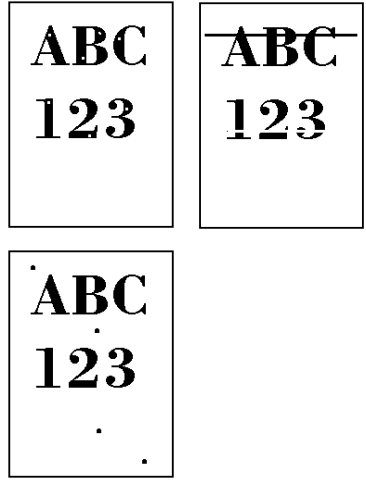
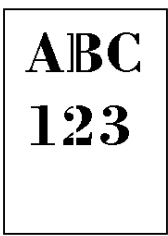
Printed Results	Corrective Action
<p>Skewed-color printout</p> 	<p>Perform color registration. Perform color registration using the printer operation panel. For full details, refer to the <i>Using the Operation Panel</i> section in the <i>Advanced Operation Guide</i>.</p>
<p>Completely blank printout</p> 	<p>Check the feed unit. Pull out paper cassette 1 and check if the feed unit is correctly installed.</p>
<p>Dropouts, horizontal streaks, stray dots</p> 	<p>Refresh drum. Refer to the following procedures on the operation panel and try cleaning the drum surface using the printer's built-in cleaning system.</p> <ol style="list-style-type: none"> 1 Press [Menu], and then press ▲ or ▼ to display <i>Others ></i>. 2 Press ▶, and then press ▲ or ▼ to display <i>>Service ></i>. 3 Press ▶, and then press ▲ or ▼ to display <i>>>Drum</i>. And then press [OK] twice. 4 The message display shows <i>Please wait</i>, and then the drum starts turning and stops after approx. 100 seconds. The printer reverts to <i>Ready</i>. <hr/> <p>Clean the separator. Open the printer left cover 1 and clean the separator with a cleaning brush. Refer to <i>Cleaning the Printer</i> on page 3-13.</p>
<p>White vertical streaks</p> 	<p>Clean the laser scanner unit. Perform the following procedures on the operation panel and try cleaning the laser scanner unit using the printer's built-in cleaning system.</p> <ol style="list-style-type: none"> 1 Press [Menu], and then press ▲ or ▼ to display <i>Others ></i>. 2 Press ▶, and then press ▲ or ▼ to display <i>>Service ></i>. 3 Press ▶, and then press ▲ or ▼ to display <i>>>LSU</i>. And then press [OK] twice. 4 The message display shows <i>Please wait</i>, and cleaning will be conducted for about 10 seconds. The printer reverts to <i>Ready</i> when cleaning is finished.

Printed Results

Corrective Action

Faint or blurred printing

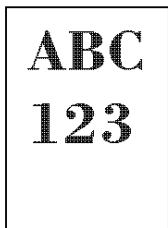
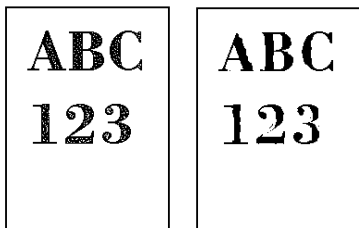

Check the operation panel.

- If the **Toner low (C/M/Y/K)** message is displayed and the **[Attention]** indicator is flashing, install a new toner kit. Refer to *Toner Container Replacement* on page 3-8.
- Make sure the paper type setting is correct.

Clean the developing unit.

Perform the following procedures on the operation panel and try cleaning the developing unit using the printer's built-in cleaning system.

- 1 Press **[Menu]**, and then press **▲** or **▼** to display **Others >**.
- 2 Press **▶**, and then press **▲** or **▼** to display **>Service >**.
- 3 Press **▶**, and then press **▲** or **▼** to display **>>DEV-CLN**. And then press **[OK]** twice.
- 4 The message display shows **Please wait (Calibrating)**, and cleaning will be conducted for about 5 minutes. The printer reverts to **Ready** when cleaning is finished.

Gray background

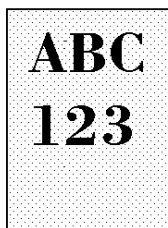

Refresh drum.

Refer to the following procedures on the operation panel and try cleaning the drum surface using the printer's built-in cleaning system.

- 1 Press **[Menu]**, and then press **▲** or **▼** to display **Others >**.
- 2 Press **▶**, and then press **▲** or **▼** to display **>Service >**.
- 3 Press **▶**, and then press **▲** or **▼** to display **>>Drum**. And then press **[OK]** twice.
- 4 The message display shows **Please wait**, and then the drum starts turning and stops after approx. 100 seconds. The printer reverts to **Ready**.

Check the operation panel.

If the **Toner low (C/M/Y/K)** message is displayed and the **[Attention]** indicator is flashing, install a new toner kit. Refer to *Toner Container Replacement* on page 3-8.

Perform color calibration.

Perform color calibration either by switching the printer off then on or using the printer operation panel. For full details, refer to the *Using the Operation Panel* section in the *Advanced Operation Guide*.

Printed Results

Corrective Action

Dirt on the top edge or back of the paper

Clean the inside of the printer.

Open the left cover 1 and check if the inside is dirty. If dirty, clean the inside with the cleaning cloth included in the toner kit.

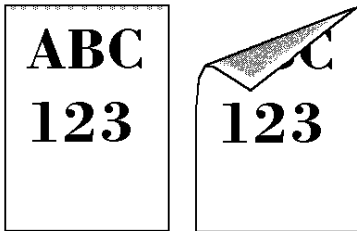

Printing incomplete or out of position

Check the file or program.

Check whether the problem is being caused by a PRESCRIBE command error. If the problem occurs only with a specific file or program, the most likely cause is an error in a parameter to a command or command syntax.

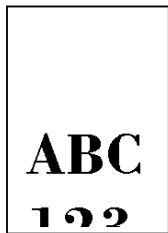

Color on the data and actual printout are different.

Perform color calibration.

Perform color calibration either by switching the printer off then on or using the printer operation panel. For full details, refer to the *Using the Operation Panel* section in the *Advanced Operation Guide*.

Error Messages

The following table lists errors and maintenance messages that can be dealt with by yourself. If `Call service` appears, turn off the printer, disconnect the power cord, and contact your service technician.

Some errors cause the alarm to sound. To stop the alarm, press **[Cancel]**.

Message	Corrective Action
Add paper MPTray	The paper has run out in the paper source displayed. Supply paper according to the paper source displayed (paper cassettes, MP tray, or optional paper feeders). This message is displayed alternately with messages indicating the printer status, such as, <code>Ready</code> , <code>Please wait</code> , <code>Processing</code> , <code>Waiting</code> , and <code>Form Feed Time Out</code> .
Add staples	The stapler unit is not installed correctly in the document finisher. Install it correctly.
Add staples Press GO	No staples are installed in the stapler. Set it in the stapler. If you wish to continue printing without the staple function, press [GO] .
Call service F###	F### represents a controller error (#=0, 1, 2, ...). Call for service. The printer does not operate when this message is displayed.
Call service ####:0123456	#### represents a mechanical error (#=0, 1, 2, ...). Call for service. The printer does not operate when this message is displayed. The total number of pages printed is also indicated, e.g. 0123456.
Cassette # not loaded	The corresponding paper cassette is not installed. Install the cassette. The cassette number can be 1 (topmost) to 4 (bottom).
Chad box full	The punch unit chad box of the option document finisher is full. Discard the chads.
Check chad box Press GO	The punch unit waste box of the document finisher is full or is not installed correctly. Check if the box is properly installed, and then discard the chads if the box is full. Press [GO] to resume printing.
Check feed unit	The feed unit is not installed correctly. Pull out paper cassette 1. Pull out the feed unit and then push it again to be installed correctly.
Check toner cont Press GO	A toner container is not installed correctly. Install it correctly. Press [GO] to resume printing.
Check waste toner box	This message warns about the following two cases. Install the new waste toner box. <ul style="list-style-type: none"> The waste toner box is not installed. The waste toner box is full.
Close finisher cover	Close the optional document finisher cover.
Close front cover	Close the printer front cover.
Close left cover #	Close the printer left cover. If the left cover of the optional paper feeder is open, 3 is displayed.

Message	Corrective Action
Close mailbox cover	Close the cover of the optional mail box.
Close top cover	Close the top cover.
Duplex disabled Press GO	You attempted to print with a paper size and paper type that cannot be used for duplex printing. Press [GO] to print onto one-side of the paper only.
e-MPS not stored Press GO	The e-MPS job cannot be stored because the RAM disk is disabled, the RAM disk size is insufficient, a hard disk is not installed, or the hard disk is full. Press [GO] to print an error report.
Error power off F###	Turn the power switch off and then back on again. If this message still remains, turn the power switch off, and contact your service representative or authorized service center.
File not found Press GO	You have attempted to print a job that is not contained in the specified virtual mailbox, or the specified virtual mailbox is not found. If Auto Error Clear is set to On, printing will automatically resume after a preset period of time. For details on Auto Error Clear, refer to <i>Using the Operation Panel</i> , section of the <i>Advanced Operation Guide</i> .
Finisher path error	The optional document finisher is not installed correctly. Install it correctly.
Finisher tray ## paper full	The finisher tray is full. When removing the paper, printing will be resumed. ## indicates the tray number.
Folding tray paper full	The folding tray has become full. You must remove all printed pages from the folding tray. When the printer senses that the folding tray is empty again, it will continue printing into the folding tray.
Format error Hard disk	The hard disk installed in the printer is not formatted, and therefore cannot be read or written. To format the hard disk, follow the procedure in the Installation Guide of the hard disk.
Format error Memory card	The memory card inserted in the printer is not formatted, and therefore cannot be read or written. To format a memory card, follow the procedure in <i>Using the Operation Panel</i> , section of the <i>Advanced Operation Guide</i> .
Hard disk err ## Press GO	A hard disk error has occurred. Look at the error code given in place of ## and refer to <i>Storage Error Codes</i> on page 4-10. To ignore the hard disk error, press [GO] .
I/F occupied	This message is displayed when you attempt to use the printer's operation panel to change the environmental settings on the interface from which data are presently being received.
ID error	The user ID entered for a private job, or a stored job is not correct. Check the user ID that you specified on the printer driver.
Incorrect slot Please reinstall	The hard disk or the network interface card has been installed in the wrong slot. Turn off the printer and reinstall the hard disk or the network interface card in the correct slot.
Insert the same Memory card	You have inserted the wrong memory card when the Insert again message was displayed. Remove the wrong memory card from the printer's memory card slot and insert the correct memory card. The printer again reads it from the beginning of the data.

Message	Corrective Action
Install MK	Replace the Maintenance Kit which is displayed on the message display. Replacement of the maintenance kit is necessary at every 300,000 images of printing and requires professional servicing. Contact your service technician.
KPDL error ## Press GO	Current print processing cannot continue because a KPDL error which is categorized by ##. To print out an error report, display > Print KPDL err(s) from the menu system, and select On. Press [GO] to resume printing. You can abandon printing by pressing [Cancel] . If Auto Error Clear is set to On, printing will automatically resume after a preset period of time. For details on Auto Error Clear, refer to <i>Using the Operation Panel</i> , section of the <i>Advanced Operation Guide</i> .
Load Cassette # (A4)/(PLAIN)	* The paper cassette matching the paper size and paper type of the print job is empty. Load paper into the paper cassette as displayed in place of #. Press [GO] to resume printing. If you want to print from a different paper source, press ▲ or ▼ to display Use alternative and you can change the source for paper feeding. After selecting a paper source and pressing [Menu] , Paper Handling > appears. By pressing the ▲, the paper type settings menu appears. After setting the correct paper type, press [OK] and printing starts. For details, refer to <i>Using the Operation Panel</i> , section of the <i>Advanced Operation Guide</i> .
Load MP Tray (A4)/(PLAIN)	* There is no paper cassette installed in the printer that matches the paper size and paper type of the print job. Set paper in the MP tray. Press [GO] to resume printing. (Note that feeding the paper having a paper size which does not match the current paper size from the MP tray can cause paper jam.) If you want to print from a different paper source, press ▲ or ▼ to display Use alternative and you can change the source for paper feeding. After selecting a paper source and pressing [Menu] , Paper Handling > appears. By pressing the ▲, the paper type settings menu appears. After setting the correct paper type, press [OK] and printing starts. For details, refer to <i>Using the Operation Panel</i> , section of the <i>Advanced Operation Guide</i> .
Mailbox tray ## paper full	The mailbox tray is full. When removing the paper, printing will be resumed. ## indicates the tray number.
Memory card err Insert again	The memory card is accidentally removed from the printer's memory card slot during reading. If you continue reading the memory card, insert the same memory card into the slot again. The printer again reads it from the beginning of the data. Also refer to <i>Insert the same Memory card</i> on page 4-7.
Memory overflow Press GO	The total amount of data received by the printer exceeds the printer's internal memory. Try adding more memory. Press [GO] to resume printing. You can abandon printing by pressing [Cancel] . If Auto Error Clear is set to On, printing will automatically resume after a preset period of time. For details on Auto Error Clear, refer to <i>Using the Operation Panel</i> , section of the <i>Advanced Operation Guide</i> .
MemoryCard err## Press GO	A memory card error has occurred. Look at the error code given in place of ## and refer to <i>Storage Error Codes</i> on page 4-10. To ignore the memory card error, press [GO] .
Missing chad box	The punch unit chad box of the document finisher is not installed correctly. Install it correctly.
Missing folding tray	The folding tray of the optional booklet folder is not installed correctly. Install the folding tray correctly.
Missing folding unit	The folding unit of the optional booklet folder is not installed correctly. Install the folding unit correctly.

Message	Corrective Action
No multi copies Press GO	Multiple copies cannot be printed because the RAM disk is disabled or the hard disk is not installed. Press [GO] to print an error report.
Paper jam #####	A paper jam has occurred. The location of the paper jam is indicated in place of the #'s. For details, refer to <i>Clearing Paper Jams</i> on page 4-11.
Print overrun Press GO	** The print job transferred to the printer was too complex to print on a page. Press [GO] to resume printing. (A page break may be automatically inserted in some places.) You can abandon printing by pressing [Cancel] . If Auto Error Clear is set to On, printing will automatically resume after a preset period of time. For details on Auto Error Clear, refer to <i>Using the Operation Panel</i> , section of the <i>Advanced Operation Guide</i> .
RAM disk error## Press GO	A RAM disk error has occurred. Look at the error code given in place of ## and refer to <i>Storage Error Codes</i> on page 4-10. To ignore the RAM disk error, press [GO] .
Replace toner C,M,Y,K	Toner has run out in the toner container(s). Replace the toner container using a new toner kit for the particular color. The printer does not operate when this message is displayed. For example, if Replace toner C,K is displayed, replace the cyan and the black toner containers.
Set paper Press GO	The MP tray is out of paper. Load paper and press [GO] . (Note that feeding the paper having a paper size which does not match the current paper size from the MP tray can cause paper jam.)
Toner low C,M,Y,K	Replace the toner container using a new toner kit. The color of the toner container that needs to be replaced is represented by C (Cyan), M (Magenta), Y (Yellow), and K (Black).
Top tray paper full	The top tray has become full (approx. 500 pages). You must remove all printed pages from the top tray. When the printer detects that the top tray is empty again, the printer will continue printing into the top tray.
Unknown toner installed	This message is displayed if the installed toner container is determined not to be an original Kyocera Mita toner container by the self-diagnostic performed after the power is switched on. If this message is displayed, the amount of toner remaining cannot be checked.
Virtual mailbox full	The storage area in the hard disk for the virtual mailboxes is full. Print out accumulated jobs in the virtual mailboxes.
Warning low memory	The printer's internal memory is running low because too many fonts and macros have been downloaded. Try deleting unnecessary fonts and macros.

* Messages separated by '()' are displayed alternately.

** After this error occurs, page protect mode will be turned on automatically. To maintain optimum use of memory during printing, we recommend you manually turn off page protect mode. Refer to the *Using the Operation Panel*, section of the *Advanced Operation Guide*.

Storage Error Codes

Hard Disk Errors

Code	Meaning
01	Hard disk format error. If this error recurs even if the power has been turned off and then on, reformat the hard disk.
02	The disk system is not installed. Recheck the requirements for using the system and the devices.
04	There is no available hard disk space. Delete unnecessary files, etc., in order to free up space.
05	The specified file does not exist in the hard disk.
06	There is no memory available to the hard disk system. Increase the available memory.
10	Formatting is not possible because host data is being spooled on the hard disk. Wait until the hard disk is ready, and then format.
85	VMB: Alias error. The alias setting was lost, or the virtual tray corresponding to the alias does not exist. Set the alias again.
97	The number of permanent code jobs that can be stored reached the limit value, and no more can be saved. Either delete some unnecessary jobs, etc., or increase the limit.
98	An unreadable page was found in a job (The job is damaged.).
99	A print job for the specified ID does not exist in the hard disk.

Memory Card Errors

Code	Meaning
01	The printer does not support the memory card inserted. The memory card must meet the requirements described in the <i>Options</i> , section of the <i>Advanced Operation Guide</i> .
02	The memory card is not installed.
04	The memory card is full and cannot hold further data. Purge unnecessary files or use a new memory card.
05	The specified file is not on the memory card.
06	Insufficient printer memory to support the memory card system. Expand printer memory.

RAM Disk Errors

Code	Meaning
01	Format error. Try turning the power off and on again.
02	RAM disk mode is Off. Turn RAM disk mode On from the operation panel.
04	No disk space. Purge unnecessary files.
05	The specified file is not on the disk.
06	Insufficient printer memory to support the RAM disk system. Expand printer memory.

Clearing Paper Jams

If the paper jams in the paper transport system, or no paper sheets were fed at all, the `Paper jam` message appears and the location of the paper jam (the component where the paper jam has occurred) is also indicated. The printer automatically goes off-line when this message is displayed. Remove the jammed paper. After removing the jammed paper, the printer will re-start printing.

Possible Paper Jam Locations

The figure below explains the printer's paper paths including the options. The locations where paper jams might occur are also shown here, with each location explained in the table below. Paper jams can occur in more than one component on the paper paths.

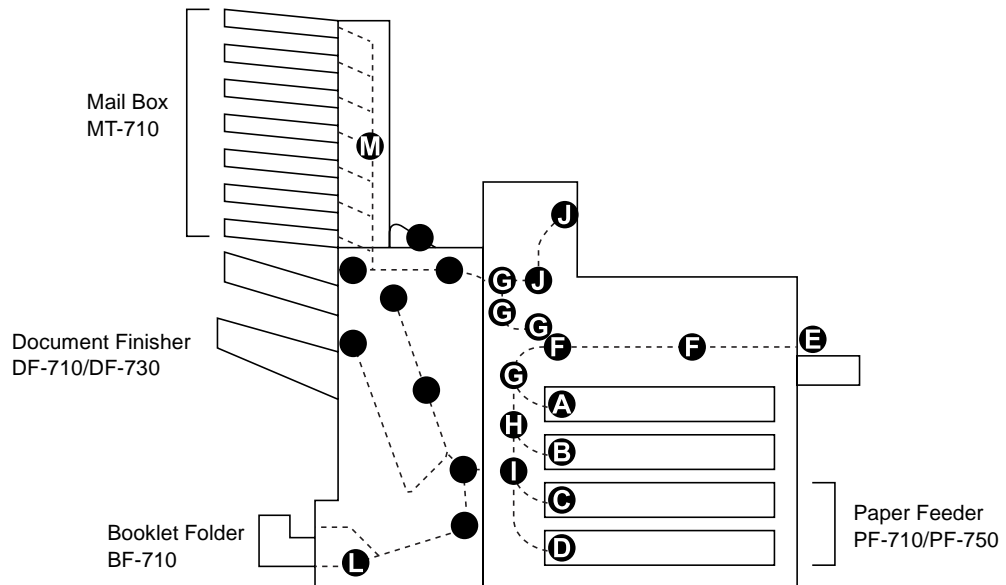

Paper jam message	Paper jam location	Description	Reference page
Paper jam Cassette 1	A	Paper is jammed at the upper cassette or inside the printer.	4-13
Paper jam Cassette 2	B	Paper is jammed at the lower cassette or inside the printer.	4-14
Paper jam Cassette 3	C	Paper is jammed at an optional paper feeder cassette. (PF-710 upper cassette, PF-750)	4-15
Paper jam Cassette 4	D	Paper is jammed at an optional paper feeder cassette. (PF-710 lower cassette)	4-15
Paper jam MP Tray	E	Paper is jammed at the MP tray.	4-16
Paper jam Feed Unit	F	Paper is jammed in the feed unit.	4-16
Paper jam Left Cover 1	G	Paper is jammed in the left cover section.	4-19

Paper jam message	Paper jam location	Description	Reference page
Paper jam Left Cover 2	H	Paper is jammed in a left cover section.	4-21
Paper jam Left Cover 3	I	Paper is jammed in the left cover section of an option unit. (PF-710, PF-750)	4-21
Paper jam Top Cover	J	Paper is jammed in a top cover section.	4-22
Paper jam Finisher	K	Paper is jammed in the paper stacker of the optional document finisher.	DF-710 or DF-730 <i>Operation Guide</i>
Paper jam Folding Unit	L	Paper is jammed in the booklet folder.	DF-710 <i>Operation Guide</i>
Paper jam Mailbox	M	Paper is jammed at the mailbox.	DF-710 <i>Operation Guide</i>

General considerations for clearing jams

Bear in mind the following considerations when attempting jam removal:

CAUTION: When pulling the paper, pull it gently so as not to tear it. Torn pieces of paper are difficult to remove and may be easily overlooked, deterring the jam recovery.

- If paper jams occur frequently, try using a different type of paper, replace the paper with paper from another ream, flip the paper stack over, or rotate the paper stack 180 degrees. Selection of paper is fully discussed in the *Handling Paper* section in the *Advanced Operation Guide*. The printer may have problems if paper jams recur after the paper was replaced.
- Whether or not the jammed pages are reproduced normally after printing is resumed depends on the location of the paper jam.

Utilizing Online Help Messages

Online help messages are available in the printer's message display to provide simple instructions for clearing jams. Press () when the paper jam message has appeared. Then a help message will appear to facilitate jam clearing in the location.

Paper Cassette

Paper Cassette 1

Remove the paper if a paper jam occurred in the paper cassette 1. Follow the instructions below.

- 1 Open the left cover 1.

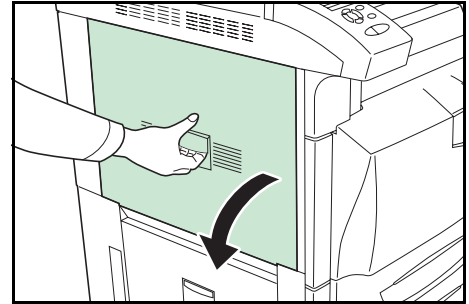

- 2 Remove the jammed paper.

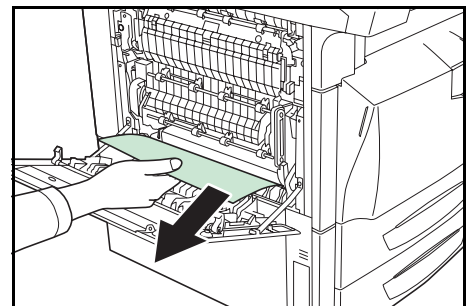

- 3 Open the duplex unit A1.

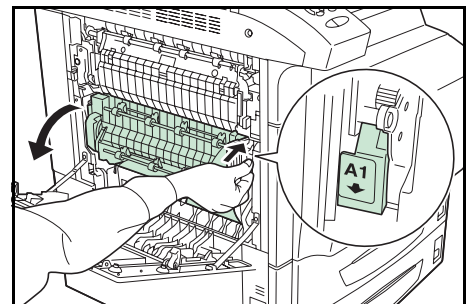

- 4 Remove the jammed paper.

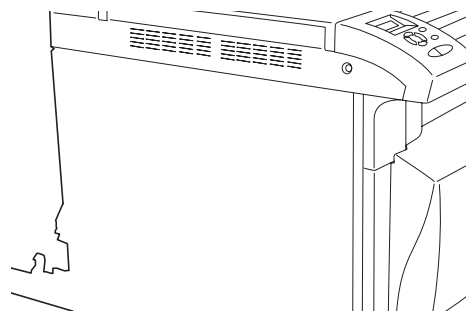

- 5 Pull out paper cassette 1.

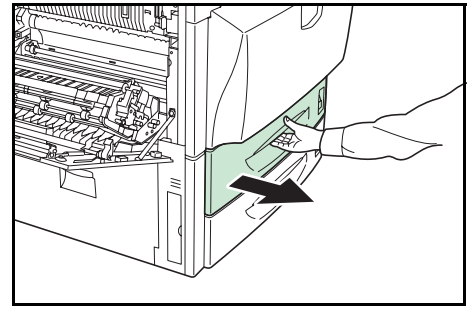

- 6 Remove the jammed paper.

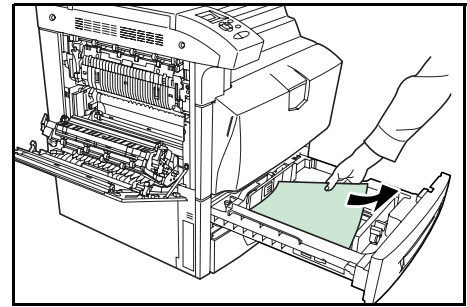

- 7 Slowly close paper cassette 1.

- 8 Close the duplex unit A1 and the left cover 1.

IMPORTANT: Push the indicated position to close left cover 1 securely.

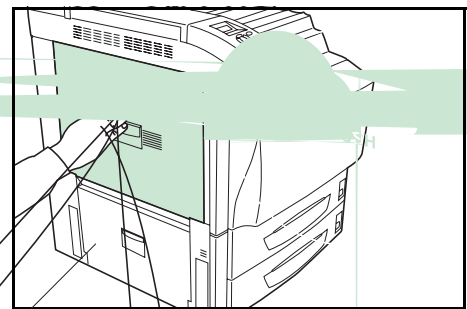

Paper C

the paper cassette 2. Follow the instructions below.

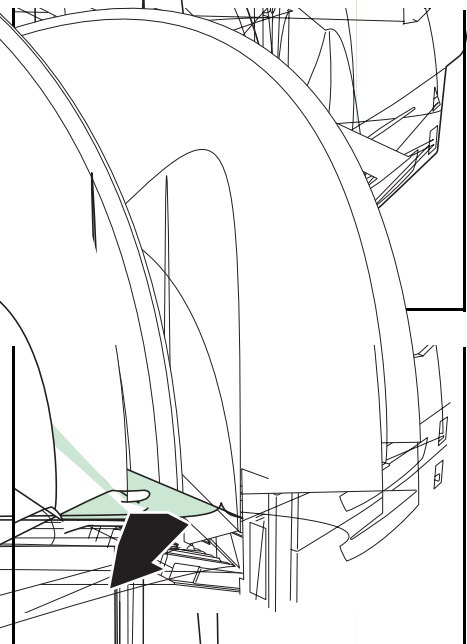

- 3 Pull out paper cassette 2.

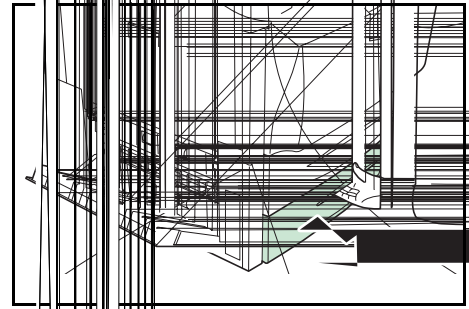

- 4 Remove the jammed paper.

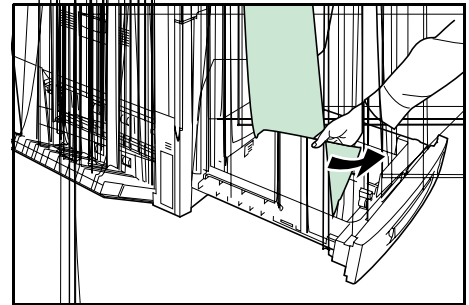

- 5 Slowly close paper cassette 2.

- 6 Close the left cover 2.

Paper Cassette 3 or 4 (option)

Remove the paper if a paper jam occurred in the optional paper feeder (PF-710/PF-750). Follow the instructions below.

- 1 Open the left cover 3.

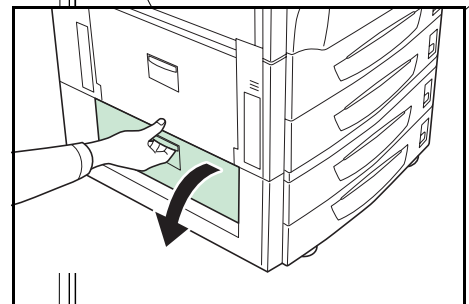

- 2 Remove the jammed paper.

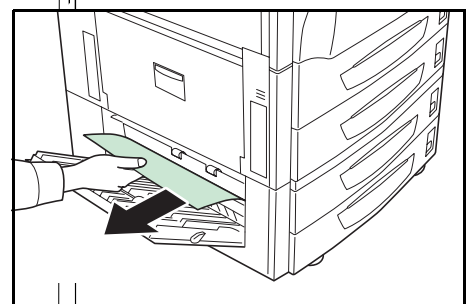

- 3 Pull out the paper cassette being used.

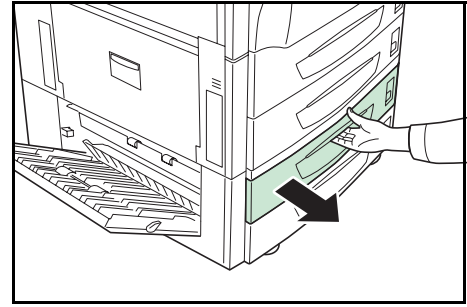

- 4 Remove the jammed paper.

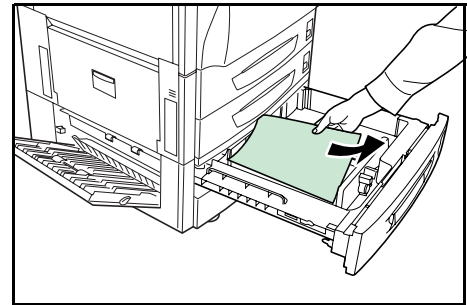

- 5 Slowly close the paper cassette.

- 6 Close the left cover 3.

MP Tray

Remove the paper if a paper jam occurred in the MP tray or feed unit. Follow the instructions below.

- 1 Open the left cover 1.

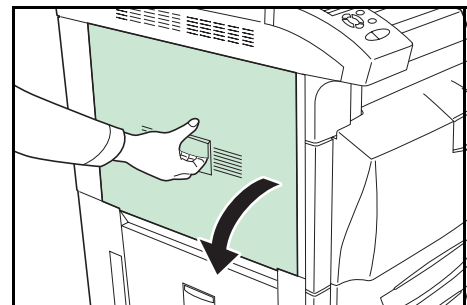

- 2 Remove the jammed paper.

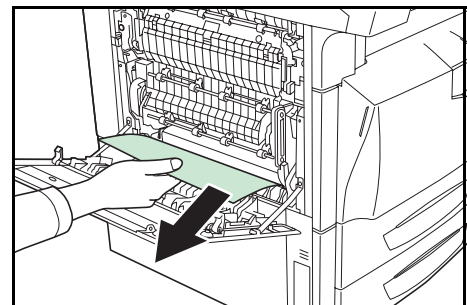

- 3 Open the duplex unit **A1**.

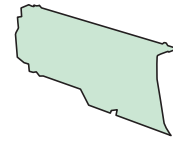

- 4 Remove the jammed paper.

- 5 Open the feed guide **B1**.

- 6 Remove the jammed paper.

- 7 Remove all the paper set in the MP tray.

- 8 Pull out paper cassette 1.

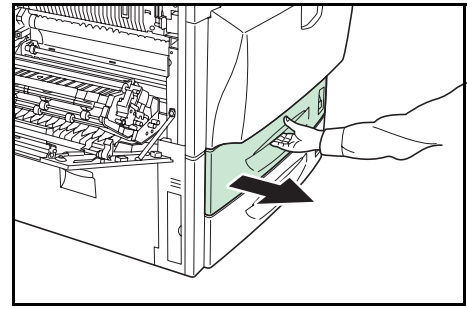

- 9 Turn the handle **B2** counterclockwise 10 times or more. The jammed paper will be moved to the inside of the left cover.

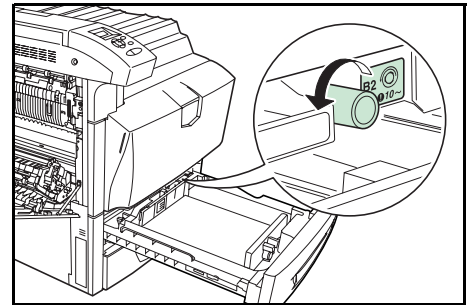

- 10 Remove the jammed paper. If paper cannot be removed, perform the steps described below.

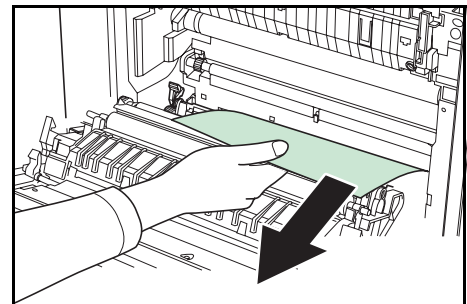

- 11 Pull out the feed unit **B3**.

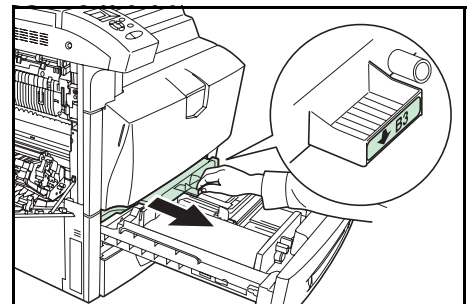

- 12 Open the cover **B4** and remove the jammed paper.

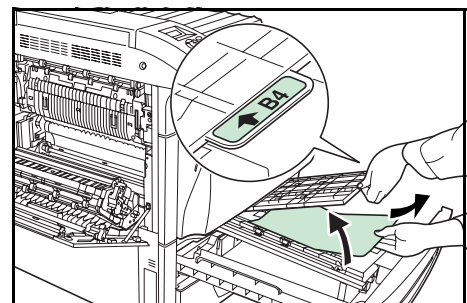

- 13** If paper is torn, pull out the feed unit **B3** completely, and uninstall it with the unit pulled up.

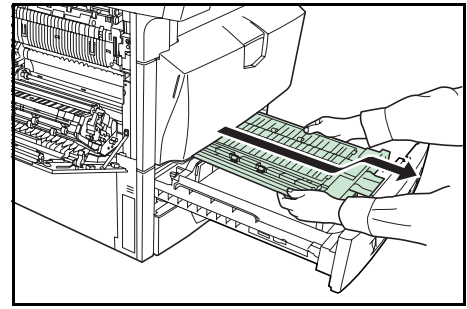

- 14** Pull out paper cassette 1 completely, and uninstall it with the cassette pulled up.

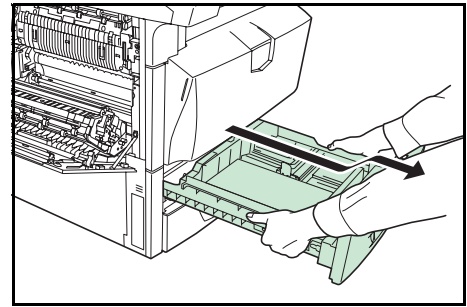

- 15** Remove the jammed paper.

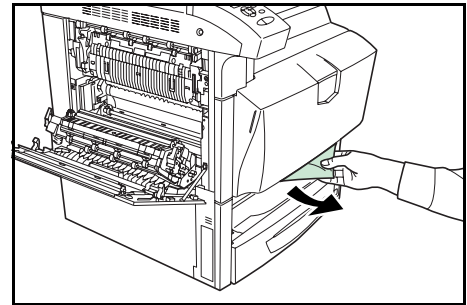

- 16** Replace paper cassette 1 and feed unit **B3**.

- 17** Close the feed guide **B1**, the duplex unit **A1** and the left cover 1.

IMPORTANT: Push the indicated position to close left cover 1 securely.

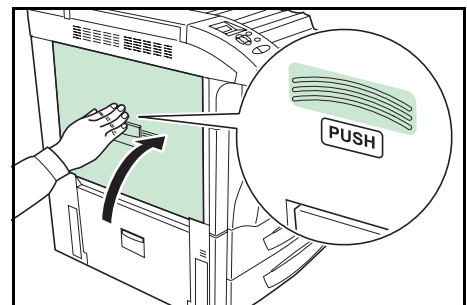

- 18** Replace the paper in the MP tray.

Left Cover 1



Remove the paper if a paper jam occurred inside the left cover 1. Follow the instructions below.

WARNING: The printer's fixing unit is extremely hot. Take sufficient care when working in this area, as there is a danger of getting burned.

- 1 Open the left cover 1.

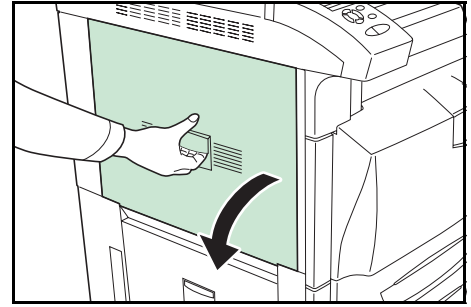

- 2 Remove the jammed paper.

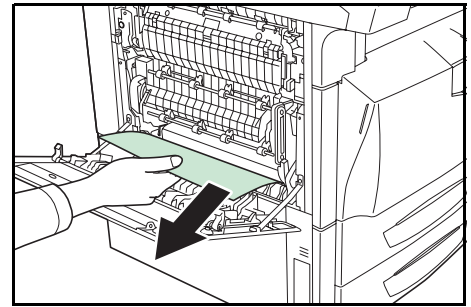

- 3 Open the duplex unit A1.

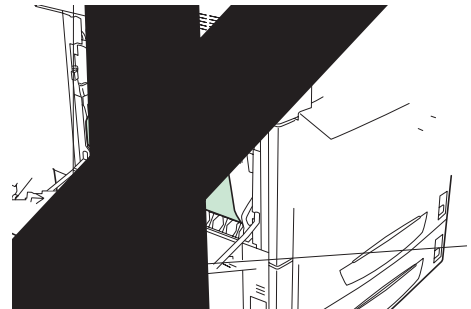

- 4 Remove the jammed paper.

- 5 Open the fixing unit cover A2.

- 6 Remove the jammed paper.

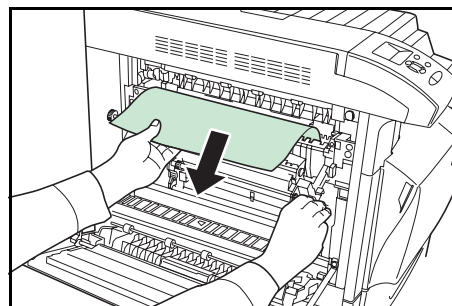

- 7 Close the fixing unit cover **A2**, the duplex unit **A1** and the left cover 1.

IMPORTANT: Push the indicated position to close left cover 1 securely.

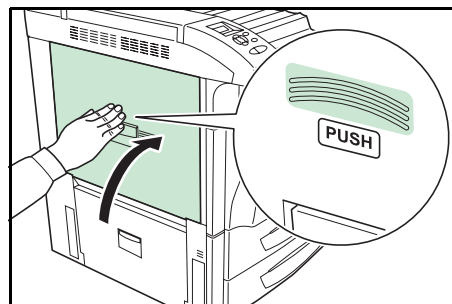

Left Cover 2

Remove the paper if a paper jam occurred inside the left cover 2 or 3. Follow the instructions below.

- 1 Open the left cover 2 or 3.

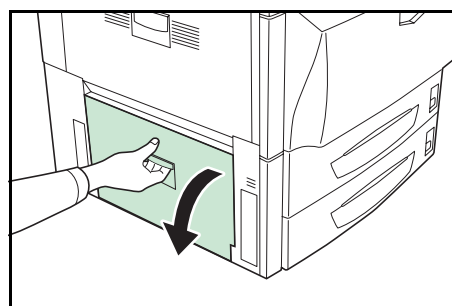

- 2 Remove the jammed paper.

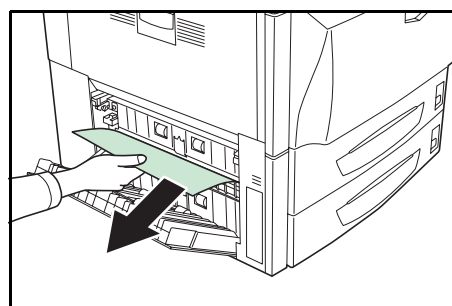

- 3 Close the left cover.

Top Cover

Remove the paper if a paper jam occurred inside the top cover. Follow the instructions below.

- 1 If you can see jammed paper from the exit, pull it out.

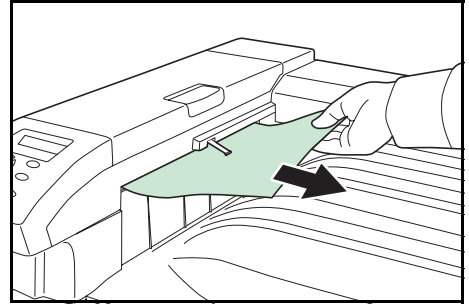

- 2 Open the top cover and remove the jammed paper.

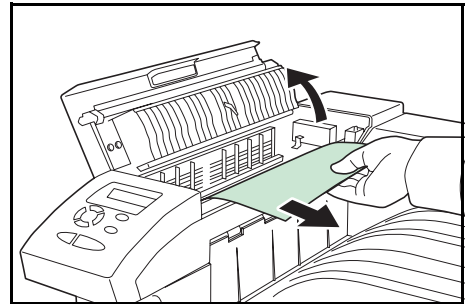

- 3 Close the top cover.

5 Specifications

NOTE: Specifications are subject to change without notice.

Item	Description	
Printing Method	Dry electrophotographic system (laser system), Tandem intermediate transfer belt system	
Printing Speed	Cassette	A4-R, B5, Letter-R: 32 ppm A3, B4, A5, Ledger, Legal: 16 ppm
	MP Tray	A4-R, B5, Letter-R: 26 ppm A3, B4, A5, Ledger, Legal: 13 ppm
Duplex Speed	Cassette	- Color A4-R, B5, Letter-R: 21 ppm A3, B4, A5, Ledger, Legal: 10 ppm - Monochrome A4-R, B5, Letter-R: 25 ppm A3, B4, A5, Ledger, Legal: 12 ppm
	MP Tray	- Color A4-R, B5, Letter-R: 17 ppm A3, B4, A5, Ledger, Legal: 8 ppm - Monochrome A4-R, B5, Letter-R: 20 ppm A3, B4, A5, Ledger, Legal: 10 ppm
Paper Size	Cassette	A3, B4, A4, B5, A5, Folio, Ledger, Legal, Letter, Oficio II, Statement
	MP Tray	A3, B4, A4, B5, A5, B6, A6, Folio, Ledger, Legal, Letter, Oficio II, Statement, Executive, ISO B5, Env. Monarch, Envelope #10, Envelope #9, Envelope #6, Envelope DL, Envelope C4, Envelope C5, 8K, 16K, Hagaki, Oufuku-Hagaki, Youkei 2, Youkei 4, and Custom
Paper Type	Cassette	Plain, preprinted, bond, recycled, vellum, rough, letterhead, color, prepunched, high quality, and custom
	MP Tray	Plain, transparency, preprinted, labels, bond, recycled, vellum, rough, letterhead, color, prepunched, envelope, cardstock, coated, thick, high quality, and custom
Paper Capacity	Cassette	- Cassette 1 500 sheets (80 g/m ² , A4/Letter or smaller), 250 sheets (80 g/m ² , B4/Legal or larger) - Cassette 2 500 sheets (80 g/m ²)
	MP Tray	100 sheets (80 g/m ² , A4/Letter or smaller), 50 sheets (80 g/m ² , B4/Legal or larger)
Output Tray Capacity	500 sheets (80 g/m ²)	
Warm-up Time (23 °C, 60%RH)	Power on	45 seconds or less
	Sleep	45 seconds or less

Specifications

Item		Description
First Print Time	Color	7.9 seconds or less
	Monochrome	5.9 seconds or less
Resolution		600 dpi
Monthly Duty	Average	15,000 pages
	Maximum	100,000 pages
Operating Systems		Microsoft Windows 95/98/Me/2000/XP Microsoft Windows NT4.0 Apple Macintosh OS 9 Apple Macintosh OS X
Controller		PowerPC750GL-800MHz
Memory	Standard	256 MB
	Maximum	1024 MB (512 MB x 2)
Interface	Standard	USB: Hi-Speed USB Parallel: IEEE1284 Network: 10BASE-T/100BASE-TX KUIO-LV slot
	Option	IB-11: Serial IB-20: 10BASE2/10BASE-T/100BASE-TX IB-21E: 10BASE-T/100BASE-TX
Operating Environment	Temperature	10 - 32.5 °C (50 - 90.5 °F)
	Relative Humidity	15 - 80%RH
	Altitude	2,000 m (6547 feet) maximum
	Illumination	1,500 lux maximum
Dimensions		605 x 660 x 597 mm 23.8 x 26 x 23.3"
Weight (without toner container)		Approx. 80 kg (176 lbs)
Operating noise (in accordance with ISO7779 [Bystander Position, sound pressure level at the front])		During printing (Color): LpA = 53.7dB (A) During printing (Monochrome): LpA = 53.3 dB (A) During standby: LpA = 43.8 dB (A) During sleep mode: immeasurably low



Headquarters:

225 Sand Road,
Fairfield, New Jersey 07004-0008
TEL : (973) 808-8444
FAX : (973) 882-6000

New York Branch:

1410 Broadway 23rd floor
New York, NY 10018
TEL : (917)

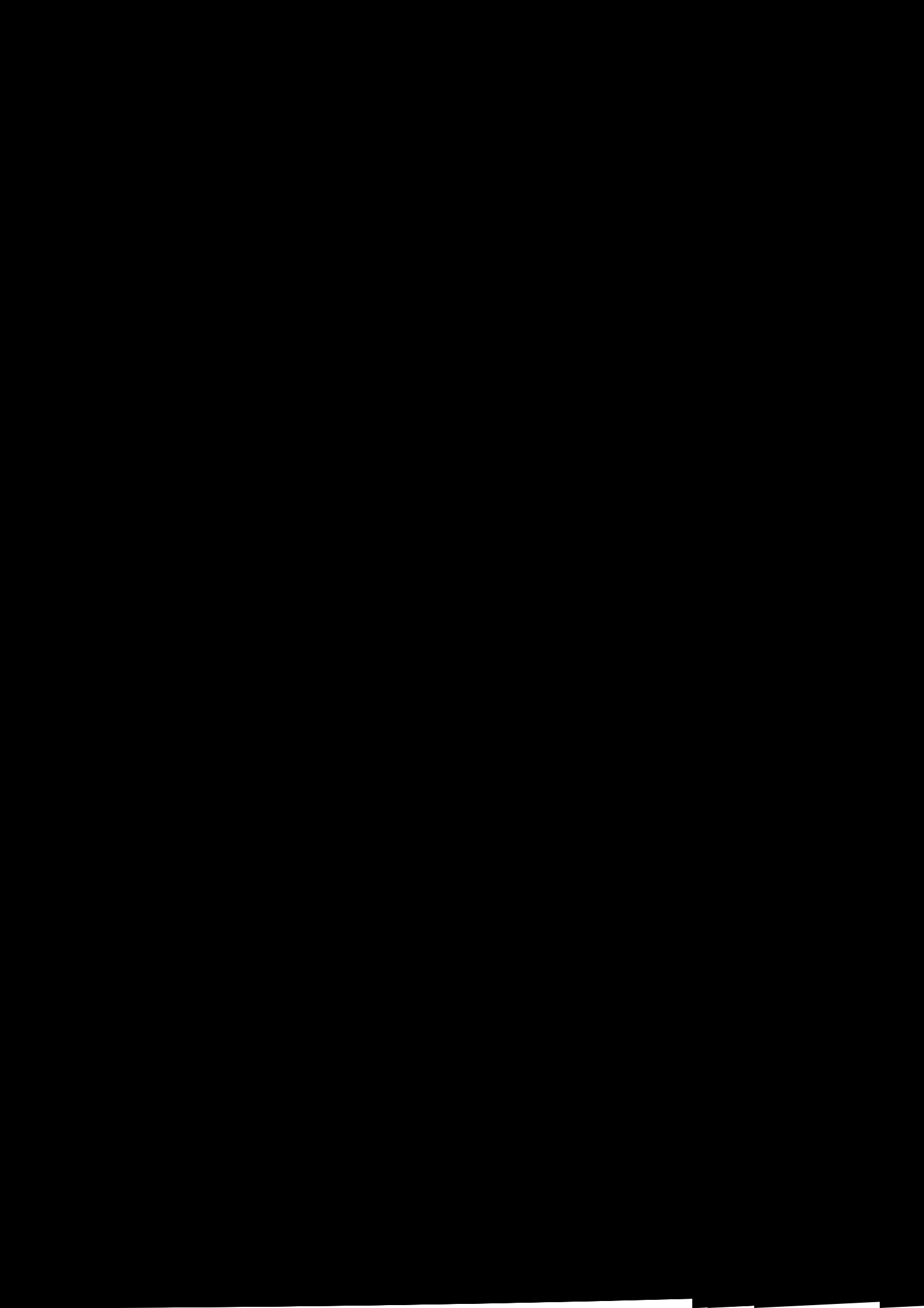



Free Manuals Download Website

<http://myh66.com>

<http://usermanuals.us>

<http://www.somanuals.com>

<http://www.4manuals.cc>

<http://www.manual-lib.com>

<http://www.404manual.com>

<http://www.luxmanual.com>

<http://aubethermostatmanual.com>

Golf course search by state

<http://golfingnear.com>

Email search by domain

<http://emailbydomain.com>

Auto manuals search

<http://auto.somanuals.com>

TV manuals search

<http://tv.somanuals.com>