

Soil Pulverizers

SP2060, SP2072, SP3072 & SP3084

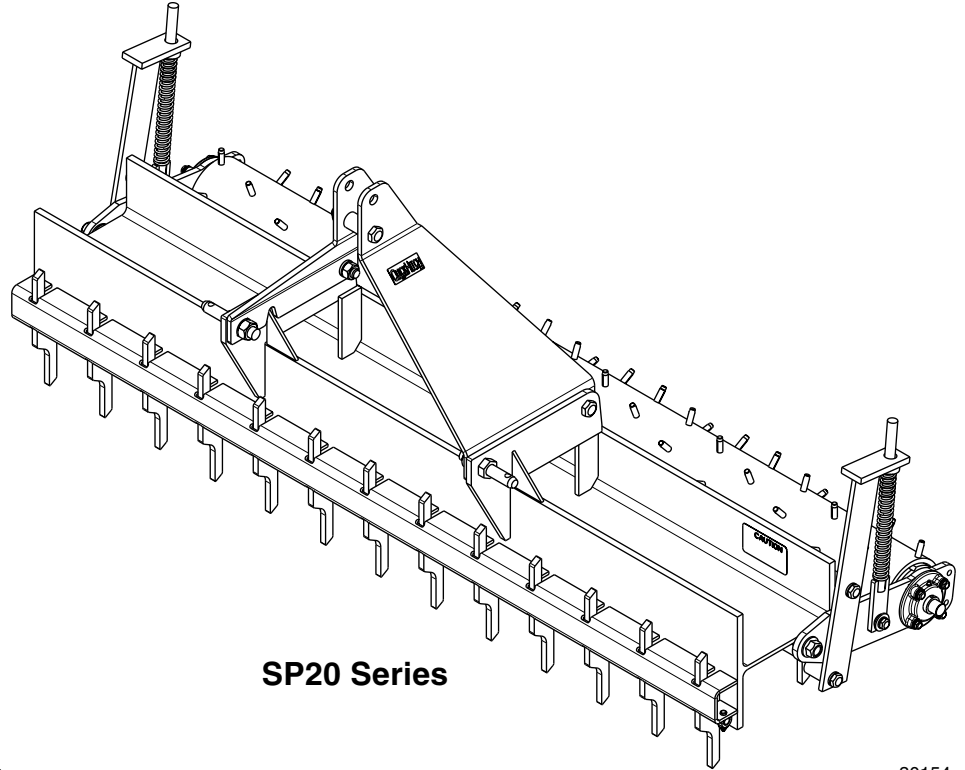

SP20 Series

30154

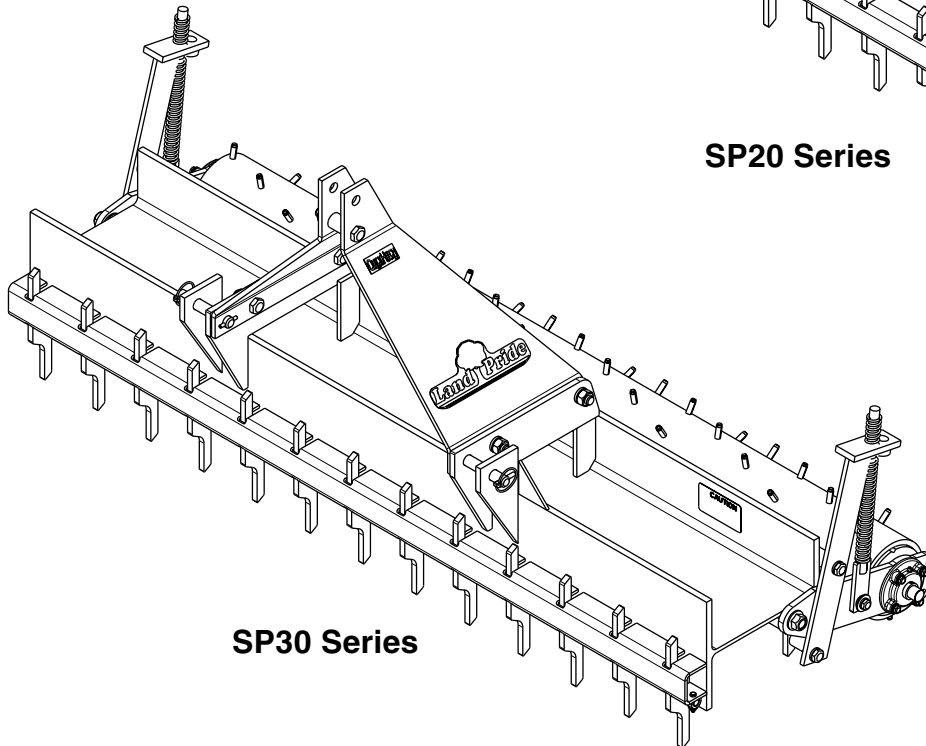

SP30 Series

30155

307-099M
Operator's Manual



Read the Operator's Manual entirely. When you see this symbol, the subsequent instructions and warnings are serious - follow without exception. Your life and the lives of others depend on it!

Cover photo may show optional equipment not supplied with standard unit.

© Copyright 2012 Printed 7/11/12



Important Safety Information	1	Section 3: Adjustments	9
Safety at All Times	1	Shanks	9
Look For The Safety Alert Symbol	1	Section 4: Maintenance & Lubrication	10
Safety Labels	4	Maintenance	10
Introduction	5	Long Term Storage	10
Application	5	Lubrication Points	10
Using This Manual	5	Rear Roller Bearing	10
Terminology	5	SP30 Double Rear Roller Bearing	10
Definitions	5	Section 5: Specifications & Capacities	11
Owner Assistance	5	Section 6: Features & Benefits	12
Serial Number	5	Section 7: Troubleshooting	13
Further Assistance	5	Section 8: Torque Values Chart	14
Section 1: Assembly & Set-Up	6	Section 9: Warranty	15
Tractor Requirements	6		
Dealer Preparations	6		
Assembly Instructions	6		
Torque Requirements	6		
SP20 Hitch Assembly	6		
Hitch Assembly	6		
Section 2: Operating	7		
Operator's Responsibilities	7		
Operating Checklist	7		
Tractor Hook-Up	7		
Transporting	8		
Adding Weight	8		
General Operating Instructions	8		



© Copyright 2012 All rights Reserved

Land Pride provides this publication "as is" without warranty of any kind, either expressed or implied. While every precaution has been taken in the preparation of this manual, Land Pride assumes no responsibility for errors or omissions. Neither is any liability assumed for damages resulting from the use of the information contained herein. Land Pride reserves the right to revise and improve its products as it sees fit. This publication describes the state of this product at the time of its publication, and may not reflect the product in the future.

Land Pride is a registered trademark.

All other brands and product names are trademarks or registered trademarks of their respective holders.

Printed in the United States of America.

These are common practices that may or may not be applicable to the products described in this manual.

Safety at All Times

Thoroughly read and understand the instructions given in this manual before operation. Refer to the "Safety Label" section, read all instructions noted on them.

Do not allow anyone to operate this equipment who has not fully read and comprehended this manual and who has not been properly trained in the safe operation of the equipment.

- ▲ Operator should be familiar with all functions of the unit.
- ▲ Operate implement from the driver's seat only.
- ▲ Make sure all guards and shields are in place and secured before operating implement.
- ▲ Do not leave tractor
- ▲ implement unattended with engine running.
- ▲ Dismounting from a moving tractor could cause serious injury or death.
- ▲ Do not allow anyone to stand between tractor and implement while backing up to implement.
- ▲ Keep hands, feet, and clothing away from power-driven parts.
- ▲ Wear snug fitting clothing to avoid entanglement with moving parts.
- ▲ Watch out for wires, trees, etc., when raising implement. Make sure all persons are clear of working area.
- ▲ Turning tractor too tight may cause implement to ride up on wheels. This could result in injury or equipment damage.
- ▲ Do not carry passengers on implement at any time.

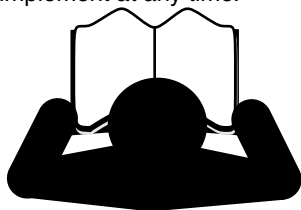

Look For The Safety Alert Symbol

The SAFETY ALERT SYMBOL indicates there is a potential hazard to personal safety involved and extra safety precaution must be taken. When you see this symbol, be alert and carefully read the message that follows it. In addition to design and configuration of equipment, hazard control, and accident prevention are dependent upon the awareness, concern, prudence, and proper training of personnel involved in the operation, transport, maintenance, and storage of equipment.

Be Aware of Signal Words

A Signal word designates a degree or level of hazard seriousness. The signal words are:

DANGER

Indicates an imminently hazardous situation which, if not avoided, will result in death or serious injury. This signal word is limited to the most extreme situations, typically for machine components that, for functional purposes, cannot be guarded.

WARNING

Indicates a potentially hazardous situation which, if not avoided, could result in death or serious injury, and includes hazards that are exposed when guards are removed. It may also be used to alert against unsafe practices.

CAUTION

Indicates a potentially hazardous situation which, if not avoided, may result in minor or moderate injury. It may also be used to alert against unsafe practices.

For Your Protection

- ▲ Thoroughly read and understand the "Safety Label" section, read all instructions noted on them.

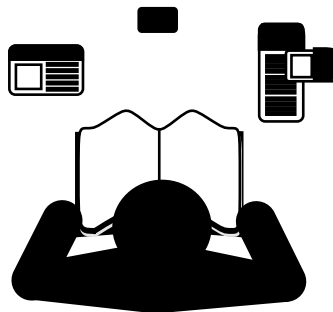

Shutdown and Storage

- ▲ Lower machine to ground, put tractor in park, turn off engine, and remove the key.
- ▲ Detach and store implements in a area where children normally do not play. Secure implement by using blocks and supports.

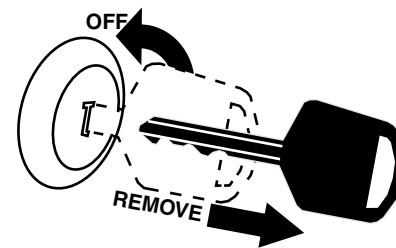

Parts Manual QR Locator

The QR (Quick Reference) code on the front cover and to the left will take you to the Parts Manual for this equipment. Download the appropriate App on your smart phone, open the App, point your phone on the QR code and take a picture.



Dealer QR Locator

The QR code on the left will link you to available dealers for Land Pride products. Refer to Parts Manual QR Locator on this page for detailed instructions.

These are common practices that may or may not be applicable to the products described in this manual.

Use Safety Lights and Devices

- ▲ Slow moving tractors, self-propelled equipment, and towed implements can create a hazard when driven on public roads. They are difficult to see, especially at night.
- ▲ Flashing warning lights and turn signals are recommended whenever driving on public roads.

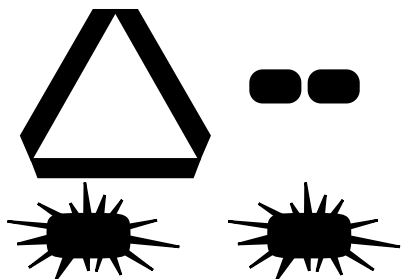

Transport Machinery Safely

- ▲ Comply with state and local laws.
- ▲ Maximum transport speed for implement is 20 mph. DO NOT EXCEED. Never travel at a speed which does not allow adequate control of steering and stopping. Some rough terrain require a slower speed.
- ▲ Sudden braking can cause a towed load to swerve and upset. Reduce speed if towed load is not equipped with brakes.

- ▲ Use the following maximum speed - tow load weight ratios as a guideline:
- ▲ **20 mph** when weight is less than or equal to the weight of tractor.
- ▲ **10 mph** when weight is double the weight of tractor.
- ▲ **IMPORTANT:** Do not tow a load that is more than double the weight of tractor.

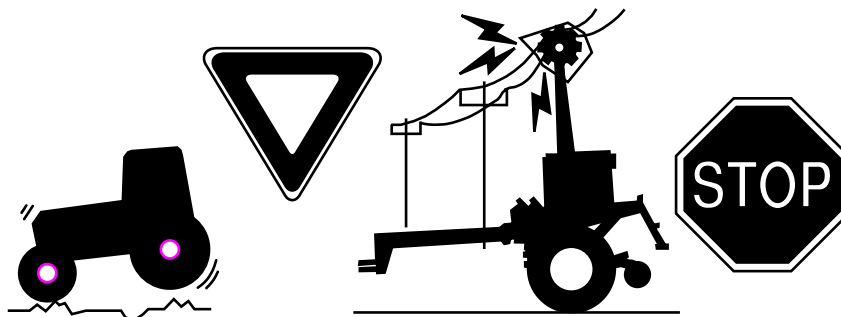

Keep Riders Off Machinery

- ▲ Riders obstruct the operator's view, they could be struck by foreign objects or thrown from the machine.
- ▲ Never allow children to operate equipment.

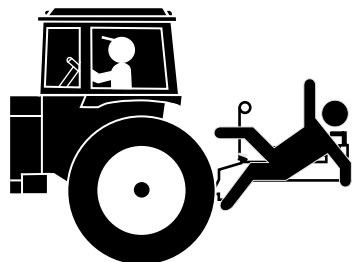

Practice Safe Maintenance

- ▲ Understand procedure before doing work. Use proper tools and equipment, refer to Operator's Manual for additional information.
- ▲ Work in a clean dry area.
- ▲ Lower the implement to the ground, put tractor in park, turn off engine, and remove key before performing maintenance.

- ▲ Allow implement to cool completely.
- ▲ Do not grease or oil implement while it is in operation.
- ▲ Inspect all parts. Make sure parts are in good condition & installed properly.
- ▲ Remove buildup of grease, oil, or debris.
- ▲ Remove all tools and unused parts from implement before operation.



These are common practices that may or may not be applicable to the products described in this manual.

Prepare for Emergencies

- ▲ Be prepared if a fire starts.
- ▲ Keep a first aid kit and fire extinguisher handy.
- ▲ Keep emergency numbers for doctor, ambulance, hospital, and fire department near phone.

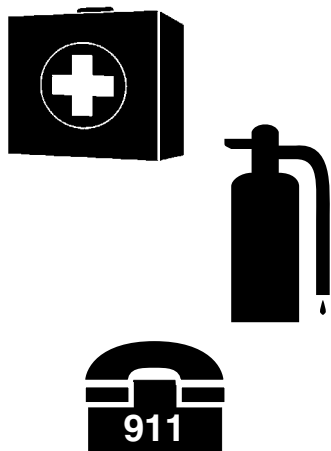

Wear Protective Equipment

- ▲ Wear protective clothing and equipment appropriate for the job. Avoid loose fitting clothing.
- ▲ Prolonged exposure to loud noise can cause hearing impairment or hearing loss. Wear suitable hearing protection such as earmuffs or earplugs.
- ▲ Operating equipment safely requires the full attention of the operator. Avoid wearing radio headphones while operating machinery.



Avoid High Pressure Fluids Hazard

- ▲ Escaping fluid under pressure can penetrate the skin causing serious injury.
- ▲ Avoid the hazard by relieving pressure before disconnecting hydraulic lines or performing work on the system.
- ▲ Make sure all hydraulic fluid connections are tight and all hydraulic hoses and lines are in good condition before applying pressure to the system.
- ▲ Use a piece of paper or cardboard, NOT BODY PARTS, to check for suspected leaks.
- ▲ Wear protective gloves and safety glasses or goggles when working with hydraulic systems.
- ▲ If an accident occurs, see a doctor immediately. Any fluid injected into the skin must be treated within a few hours or gangrene may result.



Important Safety Information

Safety Labels

Your Soil Pulverizer comes equipped with all safety labels in place. They were designed to help you safely operate your implement. Read and follow their directions.

1. Keep all safety labels clean and legible.
2. Replace all damaged or missing labels. Order new labels from your nearest Land Pride dealer. To find your nearest dealer, visit our dealer locator at landpride.com.
3. Some new equipment installed during repair requires safety labels to be affixed to the replaced component as specified by Land Pride. When ordering new components make sure the correct safety labels are included in the request.

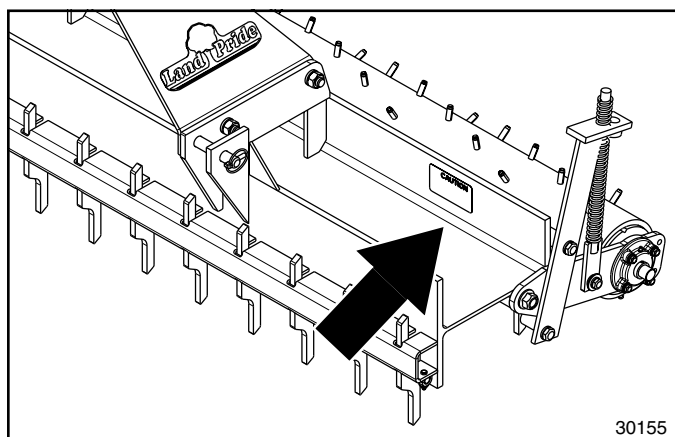

30155

4. Refer to this section for proper label placement. To install new labels:
 - a. Clean the area the label is to be placed.
 - b. Spray soapy water on the surface where the label is to be placed.
 - c. Peel backing from label. Press firmly onto the surface.
 - d. Squeeze out air bubbles with the edge of a credit card or with a similar type straight edge.

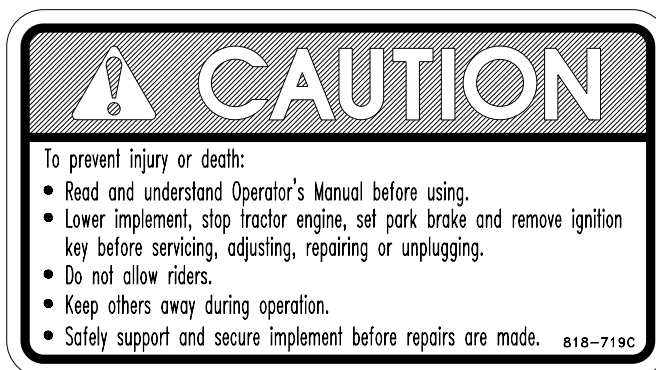

818-719C

General Caution Decal

Introduction

Land Pride welcomes you to the growing family of new product owners.

This pulverizer has been designed with care and built by skilled workers using quality materials. Proper assembly, maintenance, and safe operating practices will help you get years of satisfactory use from this pulverizer.

Application

The SP20 and SP30 Soil Pulverizers are designed and built by Land Pride to loosen, pulverize, and level packed or encrusted soils in preparation for seeding or laying of new sod. Both the 20 and 30 Series Pulverizers are adapted for Category 1 three-point hitch mounting. The 20 series has a minimum 35 hp tractor requirement while the 30 Series has a minimum 50 hp requirement.

Land Pride Soil Pulverizers come in 60", 72", and 84" working widths making them well suited for use by landscapers, rental yards, construction contractors, and professional turf managers. Applications include golf courses, housing developments, athletic fields, nurseries, sod farms, transportation right-of-ways, and park systems.

See "**Specifications & Capacities**" on page 11 and "**Features & Benefits**" on page 12 for additional information and performance enhancing options.

Using This Manual

- This Operator's Manual is designed to help familiarize you with safety, assembly, operation, adjustments, troubleshooting, and maintenance. Read this manual and follow the recommendations to help ensure safe and efficient operation.
- The information contained within this manual was current at the time of printing. Some parts may change slightly to assure you of the best performance.
- To order a new Operator's or Parts Manual contact your authorized dealer. Manuals can also be downloaded, free-of-charge from our website at www.landpride.com.

Terminology

"Right" or "Left" as used in this manual is determined by facing the direction the machine will operate while in use unless otherwise stated.

Definitions

IMPORTANT: A special point of information related to the following topic. Land Pride's intention is this information must be read & noted before continuing.

NOTE: A special point of information that the operator should be aware of before continuing.

Owner Assistance

The Online Warranty Registration or Warranty Registration card should be completed by the dealer at the time of purchase. This information is necessary to provide you with quality customer service.

The parts on your Soil Pulverizer have been specially designed by Land Pride and should only be replaced with genuine Land Pride parts. Contact a Land Pride dealer if customer service or repair parts are required. Your Land Pride dealer has trained personnel, repair parts, and equipment needed to service the implement.

Serial Number

Model No. _____ Serial No. _____

For quick reference and prompt service, record model number and serial number in the spaces provided above and again on warranty page 15. Always provide model number and serial number when ordering parts and in all correspondences with your Land Pride dealer. Refer to Figure 1 for location of your serial number plate.

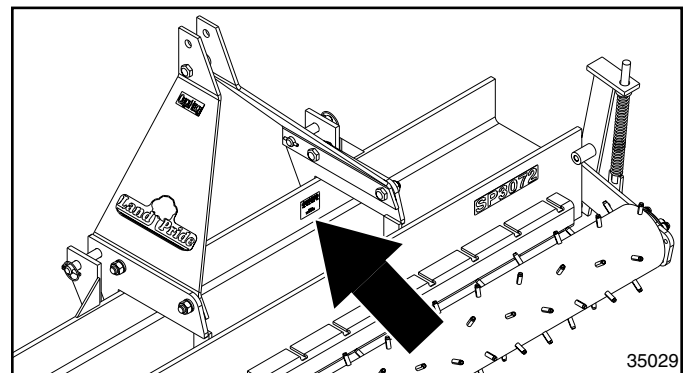

Serial Number Plate Location
Figure 1

Further Assistance

Your dealer wants you to be satisfied with your new Soil Pulverizer. If for any reason you do not understand any part of this manual or are not satisfied with the service received, the following actions are suggested:

1. Discuss the matter with your dealership service manager making sure he is aware of any problems you may have and that he has had the opportunity to assist you.
2. If you are still not satisfied, seek out the owner or general manager of the dealership, explain the problem and request assistance.
3. For further assistance write to:

Land Pride Service Department
1525 East North Street
P.O. Box 5060
Salina, Ks. 67402-5060

E-mail address
lp servicedept@landpride.com

Section 1: Assembly & Set-Up

Tractor Requirements

Tractor horsepower and hitch category should be within the range noted below. Tractors outside the horsepower range must not be used.

- SP20 Tractor Horsepower Rating 25-35 HP
- SP30 Tractor Horsepower Rating 30-50 HP
- SP20 & SP30 Hitch Category Cat. I

NOTE: Front tractor weights and/or ballast to tires may be required to offset weight of unit. Consult your tractor manual for details to install ballast weights.

Dealer Preparations



CAUTION!

Never allow anyone under unit while unloading.

Using a lifting device of adequate size to remove crate from flat bed. Place on a smooth flat work surface and uncrate unit. This unit is shipped partially assembled. It is the dealership's responsibility to finish assembly of the unit. This section covers the proper way for the Land Pride dealer to assemble the pulverizer.

Assembly Instructions

Review all safety instructions printed in this manual before assembling the pulverizer.

NOTE: Do not tighten hardware until assembly is complete.

Torque Requirements

Refer to "Torque Values Chart" on page 14 to determine correct torque values when tightening hardware.

SP20 Hitch Assembly

Refer to Figure 1-1:

1. Install upper hitch plates (#1 & #2) inside mounting bracket plates with 3/4"-10 x 2" GR5 cap screws (#4), lockwashers (#8), and hex nuts (#6).
2. Insert spacer (#3) between upper hitch plates, install 3/4"-10 x 4" GR5 cap screw (#5), lockwashers (#8), and hex nut (#6).
3. Make sure 3/4" hex jam nuts (#10) is screwed fully onto lower hitch pins (#11).
4. Install lower 3-point hitch pins (#11) to the pulverizer frame with 7/8" lock washers (#9) and hex nuts (#7).
5. Tighten all Hardware to the proper torque values.

Hitch Assembly

Refer to Figure 1-2:

1. Install upper hitch plates (#2 & #3) inside mounting brackets with 3/4"-10 x 2" GR5 cap screws (#5), lockwashers (#8), and hex nuts (#7).

2. Insert spacer (#4) between upper hitch plates. Install 3/4"-10 x 4" GR5 cap screw (#6), lockwasher (#8), and hex nut (#7).
3. Insert lower 3-point hitch pins (#9) into clevis lugs. Secure hitch pins with linch pins (#9).
4. Tighten all Hardware to the proper torque values.

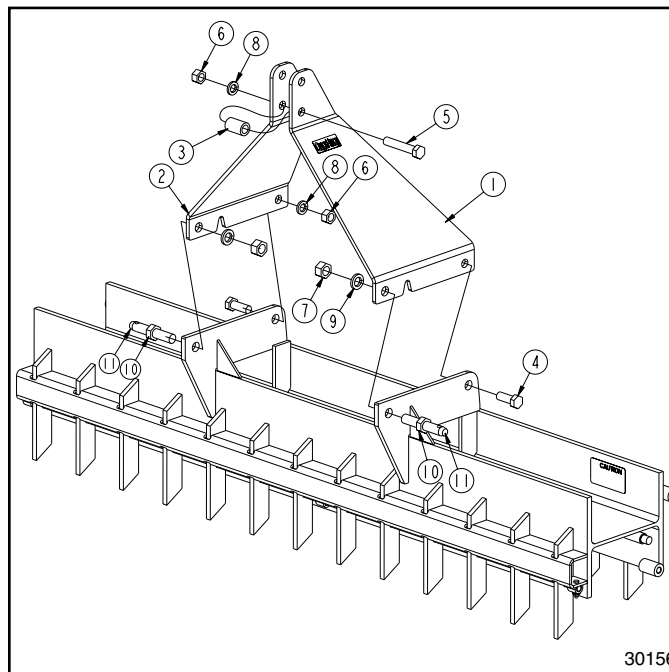

**Hitch Assembly
Figure 1-1**

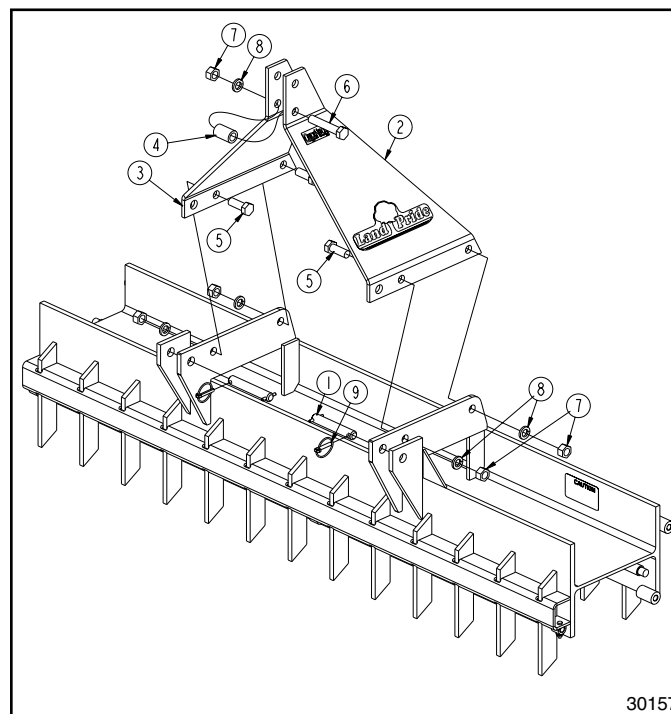

**Hitch Assembly
Figure 1-2**

Section 2: Operating

Operator's Responsibilities

Hazard control and accident prevention are dependent upon the awareness, concern, prudence and proper training involved in the operation, transport, storage, and maintenance of the Soil Pulverizer. Therefore, it is absolutely essential that no one operates the Soil Pulverizer without first having read, fully understood and become totally familiar with the Operator's Manual. Make sure the operator has completed the Operating Checklist below.

Operating Checklist

✓	Check	Page No.
	Read and follow all Safety Rules carefully. Refer to "Important Safety Information".	Page 1
	Make sure all guards and shields are in place. Refer to "Important Safety Information".	Page 1
	Read and follow Hook-up & preparation instructions. Be sure all pins have been installed and are secured. Refer to "Section 1: Assembly & Set-Up".	Page 6
	Read and follow all operating instructions. Make sure the operator understands how to operate the Soil Pulverizer. Refer to "Section 2: Operating".	Page 7
	Read and make all required adjustments. Be sure all pins have been installed and are secured. Refer to "Section 3: Adjustments".	Page 9
	Read and follow all Maintenance Instructions. Refer to "Section 4: Maintenance & Lubrication".	Page 10
	Make sure there are no hydraulic leaks on the unit. Refer to "Avoid High Pressure Fluids Hazard".	Page 3
	Check Soil Pulverizer initially and periodically for loose bolts and pins. Refer to "Torque Values Chart".	Page 14

WARNING!

It is the operator's responsibility not to allow anyone near the Soil Pulverizer during its operation.

CAUTION!

Be sure that you are not working over any underground wiring, pipes, or other obstructions. If there is any doubt, call your public service agency.

CAUTION!

Always keep your feet and legs out from under the shanks when adjusting height of shanks. It is possible the shanks could slip and fall causing injury to your feet and/or legs.

- Follow all directions on the safety labels.
- Do not allow anyone to operate this Soil Pulverizer who has not been properly trained in its safe operation.
- Do not let anyone under the age of 16 operate the Soil Pulverizer.
- Use the Soil Pulverizer for its intended purpose only.

- Never carry passengers or use the Soil Pulverizer as a wagon to carry things.
- Never use the Soil Pulverizer to pull or tow other equipment or objects.
- Make sure all safety labels are in their proper location and in good condition before operation.
- Never work under the Soil Pulverizer without properly blocking pulverizer up.
- Before working the soil contact your local utility services, so that they may mark location of any underground utility services in the area. Be sure to ask how close you can work to the marks or flags they positioned.
- Do not alter the Soil Pulverizer in a way which will adversely affect its performance or reliability or use the Soil Pulverizer for a purpose for which it was not designed.

Tractor Hook-Up

Refer to Figure 2-1:

DANGER!

Tractor hook-up to equipment is dangerous and can result in serious injury or death. **Do not** allow anyone to stand between the Soil Pulverizer and tractor during hook-up operations. **Do not** operate hydraulic 3-point lift controls while someone is directly behind the tractor or near the Soil Pulverizer.

A 3-Point Category I hitch is required.

1. Slowly back tractor up to the Soil Pulverizer and use tractor's 3-point hydraulic control to align the lower hitch link holes with the clevis lug holes on the Soil Pulverizer.
2. Engage tractor park brake, shut tractor engine off and remove key before dismounting from tractor.
3. With tractor's lower hitch arms aligned and positioned in the clevises, attach lower arms to the clevises with hitch pins and secure with linchpins.

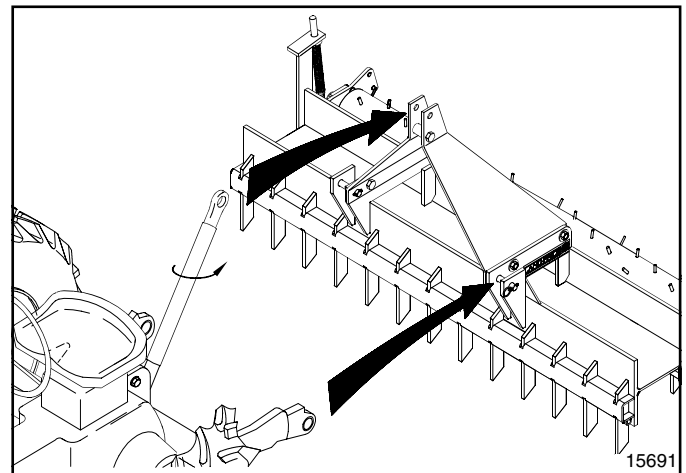

Tractor Hook-Up
Figure 2-1

Section 2: Operating

4. Connect top center link to the upper hitch with top link pin (supplied by customer).
5. Return to the tractor and slowly operate the tractor's 3-Point hydraulic control up and down to check for clearance between the tires, frame, drawbar etc. Move or remove drawbar if it interferes with the Soil Pulverizer.
6. Manually adjust one of the two lower lift arms up or down to level the Soil Pulverizer from left to right.
7. Manually adjust the length of the top-link to level the Soil Pulverizer from front to rear.

Transporting

CAUTION!

When traveling on public roads at night or during the day, use accessory lights and devices for adequate warning to operators of other vehicles. Comply with all federal, state, and local laws.

1. Be sure to reduce tractor ground speed when turning; and leave enough clearance so the Soil Pulverizer does not contact obstacles such as buildings, trees, or fences.
2. Select a safe ground travel speed when transporting from one area to another.
3. When traveling on roadways, transport in such a way that faster moving vehicles may pass you safely.
4. When traveling over rough or hilly terrain, shift tractor to a lower gear.

Adding Weight

Up to 400 lbs of weight may be applied by installing bricks or blocks in frame for additional weight if required by ground conditions.

General Operating Instructions

DANGER!

Operator to wear Seat Belt at all times while operating implement.

WARNING!

Speeds in excess of 5 MPH can damage frame & or shanks

IMPORTANT: Do Not turn tractor with pulverizer shanks in the ground. Damage to shanks will occur.

Before putting your Land Pride Pulverizer into service you must thoroughly review the Operator's Manual. Once you have read the Operator's Manual and properly mounted the pulverizer on your tractor, you should be ready to head for the work site. You should have already removed any sizeable sticks, rocks, or extraneous debris from this area. Do not attempt to rip up concrete, black top, asphalt, or large rocks.

With tractor stopped, lower 3-point of tractor down until all weight is off the tractor. Pull ahead slowly to get the shanks to start digging. Scarifying and pulverizing action will commence as soon as the rear roller touches the ground and begins to roll. Increase ground speed once shanks and roller have entered the ground. Do not exceed 5 MPH and make straight passes only. When you reach the end of a pass, raise tractor's 3-point up before turning. Trying to turn with unit in the ground will damage the scarifier shanks and can damage the pulverizer roller.

If ground conditions are extremely hard and the scarifier shanks are not achieving adequate penetration, you may need to add additional weight to the top frame. Up to 400 lbs can be added to this area.

If the pulverizing roller is bouncing and not staying in uniform contact with the ground, the down pressure of the roller can be adjusted by the spring tensioners located at both ends of the pulverizer.

If you are getting a build-up on the rear roller, pulverizing operations should be discontinued until the ground is dry enough to work. If the ground needs more cultivation than can be accomplished in one pass, continue to make additional passes until the desired finish is achieved. Owners of the Model 30 Series Land Pride Pulverizers can attach an additional optional rear mounted pulverizer roller to achieve a more professional finish in less time.

Once you are finished using your pulverizer, park it on a dry and level surface, clean it, and make it ready for the next use. With a little practice you will be able to achieve professional results from your Land Pride Pulverizer.

Shanks

Refer to Figure 3-1:

Shanks can be removed & installed upside down to give dual life to shanks.

5. Remove cotter pin (#1) from one end of pulverizer.
6. Pull rod (#2) from channel.
7. Flip shanks (#3) over and reinstall rod (#2).
8. Reinstall cotter pin (#1).

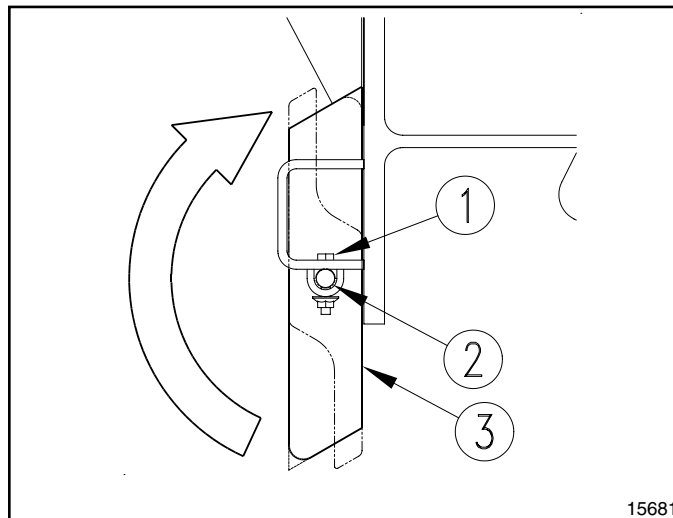

Shanks
Figure 3-1

Section 4: Maintenance & Lubrication

Maintenance

Proper servicing and adjustment is the key to the long life of any implement. With careful inspection and routine maintenance, you can avoid costly down time and repair.

Check all bolts after using unit for several hours to be sure they are tight. Replace any worn, damaged, or illegible safety labels by obtaining new labels from your Land Pride Dealer.

The parts on your Soil Pulverizer have been specially designed and should only be replaced with genuine Land Pride parts. Do not alter the pulverizer in a way which will adversely affects its performance.

Long Term Storage

Clean, inspect, service, and make necessary repairs to the pulverizer when parking it for long periods and when parking it at the end of a working season. This will help ensure the pulverizer is ready for field use the next time you hook-up to it.

1. Clean off any dirt and grease that may have accumulated on the pulverizer and moving parts. Scrape off compacted dirt and then wash surface

thoroughly with a garden hose. A coating of oil may be applied to the wear areas to minimize oxidation.

2. Check shanks a for wear and replace if necessary. See **“Shanks”** on page 9.
3. Repaint parts where paint is worn or scratched to prevent rust. Ask your Land Pride dealer for aerosol touch-up paint. They are also available in touch-up bottles with brush, quarts, and gallon sizes by adding TU, QT, or GL to the end of the aerosol part number.

Land Pride Aerosol Touch-up Paint

Part No.	Part Description
821-011C	PAINT LP BEIGE AEROSOL SPRAY CAN
821-002C	PAINT LP BLACK AEROSOL SPRAY CAN
821-066C	PAINT ORANGE AEROSOL SPRAY CAN

4. Replace all damaged or missing decals.
5. Lubricate as noted below.
6. Store pulverizer on a level surface in a clean, dry place. Inside storage will reduce maintenance and make for a longer pulverizer life.

Lubrication Points

Lubrication Legend

- Multi-purpose spray lube
- Multi-purpose grease lube
- Multi-purpose oil lube
- Intervals in hours at which lubrication is required

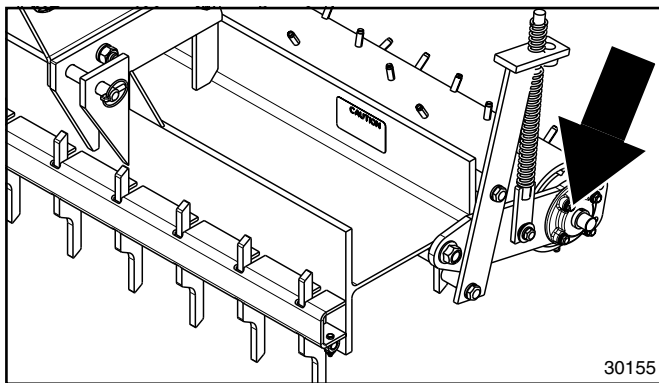

Rear Roller Bearing

Both ends

Type of Lubrication: Multi-purpose grease lube

Quantity = As Required

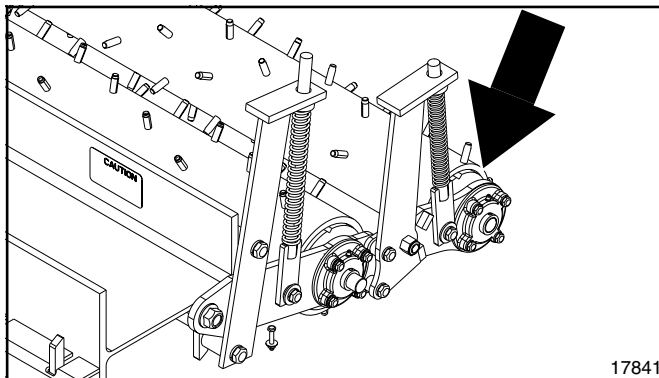

SP30 Double Rear Roller Bearing

Both ends

Type of Lubrication: Multi-purpose grease lube

Quantity = As Required

SP2060, SP2072, SP3072 & SP3084

	SP2060	SP2072	SP3072	SP3084
Width	60"	72"	72"	84"
Weight (With Single Roller- lbs.)	491	561	671	721
Max Engine Hp.	35 Hp.	35 Hp.	50 Hp.	50 Hp
Number Of Shanks	21	25	25	29
Number Of Spikes - Single Roller	86	103	103	116
Number Of Spikes - Double Roller	N/A	N/A	206	232
Height	36 1/2"		36 1/2"	
Front To Back Length Single Roller	24"		27 1/4"	
Front To Back Length Double Roller	N/A		35 1/4"	
Shank Spacing	2 13/16"		2 13/16"	
Spiked Roller Tube Diameter	5 9/16" O.D		6 5/8" O.D. (Optional Second Roller 5 9/16")	
H-Beam	10"		12"	
A-Frame	3/8" Plate			
Springs-Front Roller	32 lbs./inch		32 lbs./inch	
Springs - Rear Roller	N/A	N/A	15 lbs./inch	
Spike Material	3/8" x 1 1/4" Steel, Replaceable Heat Treated Sleeves		3/8" x 1 1/4" Steel, Replaceable Heat Treated Sleeves	
Hitch	Cat. 1		Cat. 1	

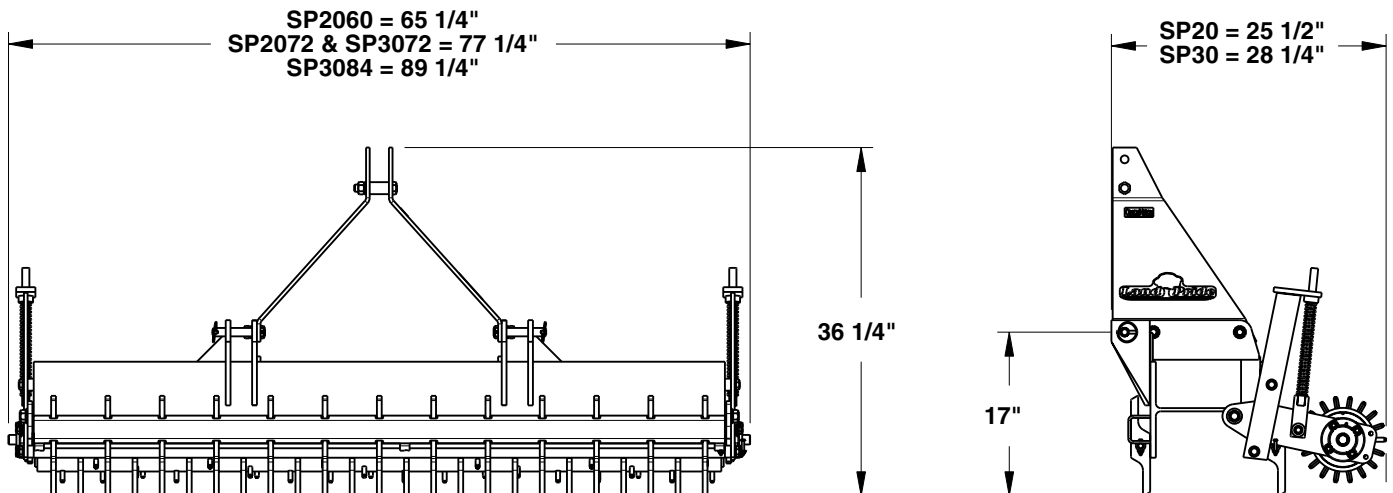

35031

SP20 & SP30 Series Soil Pulverizers

Features	Benefits
Working widths	20 Series: 60", 72"; 30 Series: 72", 84"
HP Range	20 Series: 20-35 HP; 30 Series: 30-50 HP
Replaceable heat-treated sleeves	Heat-treated replaceable sleeves on roller protect spike. Easily replace the sleeve when worn vs. replacing entire spike.
3/8" Steel spikes welded to the roller's surface	Spikes are welded to the roller's surface rather than to a hole. Damaged spikes can be cut off and replaced.
Self-aligning bearings with double lip seals on rear roller	Self-aligning bearings conform to the roller and shafts.
1" Diameter shaft in roller	Heavy shaft can handle the shock loads from the roller.
Roller has high number of steel spikes	Better pulverization, more spikes than most competitors
H Beam	20 Series: H Beam-10"; 30 Series: H Beam-12"
10 1/2" x 2" x 2" Scarifier teeth	Scarifier teeth are heat-treated for long life and can be reversed when one side wears down.
Warranty	One year parts and labor
Fits Land Pride Quick-Hitch	Cat. 1 3-point fits Land Pride Quick-Hitch for easy on-off with one person.



Problem	Solution
Roller or Rollers not staying on ground, Bouncing.	Adjust spring tension
Shanks bending sideways.	Lift shanks out of ground while turning
Bending frame and or shanks	Do not rip up concrete, asphalt, or blacktop. Do not hit solid objects.
Shanks won't go into ground	3-point has not been lowered
	weight may need to be added to frame (refer to adding weight in operating instructions).
	Do not rip up concrete, asphalt, or blacktop

Torque Values Chart for Common Bolt Sizes													
Bolt Size (Inches)	Bolt Head Identification						Bolt Size (Metric)	Bolt Head Identification					
	Grade 2		Grade 5		Grade 8			Class 5.8		Class 8.8		Class 10.9	
in-tpi ¹	N·m ²	ft-lb ³	N·m	ft-lb	N·m	ft-lb	mm x pitch	N·m	ft-lb	N·m	ft-lb	N·m	ft-lb
1/4" - 20	7.4	5.6	11	8	16	12	M 5 X 0.8	4	3	6	5	9	7
1/4" - 28	8.5	6	13	10	18	14	M 6 X 1	7	5	11	8	15	11
5/16" - 18	15	11	24	17	33	25	M 8 X 1.25	17	12	26	19	36	27
5/16" - 24	17	13	26	19	37	27	M 8 X 1	18	13	28	21	39	29
3/8" - 16	27	20	42	31	59	44	M10 X 1.5	33	24	52	39	72	53
3/8" - 24	31	22	47	35	67	49	M10 X 0.75	39	29	61	45	85	62
7/16" - 14	43	32	67	49	95	70	M12 X 1.75	58	42	91	67	125	93
7/16" - 20	49	36	75	55	105	78	M12 X 1.5	60	44	95	70	130	97
1/2" - 13	66	49	105	76	145	105	M12 X 1	90	66	105	77	145	105
1/2" - 20	75	55	115	85	165	120	M14 X 2	92	68	145	105	200	150
9/16" - 12	95	70	150	110	210	155	M14 X 1.5	99	73	155	115	215	160
9/16" - 18	105	79	165	120	235	170	M16 X 2	145	105	225	165	315	230
5/8" - 11	130	97	205	150	285	210	M16 X 1.5	155	115	240	180	335	245
5/8" - 18	150	110	230	170	325	240	M18 X 2.5	195	145	310	230	405	300
3/4" - 10	235	170	360	265	510	375	M18 X 1.5	220	165	350	260	485	355
3/4" - 16	260	190	405	295	570	420	M20 X 2.5	280	205	440	325	610	450
7/8" - 9	225	165	585	430	820	605	M20 X 1.5	310	230	650	480	900	665
7/8" - 14	250	185	640	475	905	670	M24 X 3	480	355	760	560	1050	780
1" - 8	340	250	875	645	1230	910	M24 X 2	525	390	830	610	1150	845
1" - 12	370	275	955	705	1350	995	M30 X 3.5	960	705	1510	1120	2100	1550
1-1/8" - 7	480	355	1080	795	1750	1290	M30 X 2	1060	785	1680	1240	2320	1710
1-1/8" - 12	540	395	1210	890	1960	1440	M36 X 3.5	1730	1270	2650	1950	3660	2700
1-1/4" - 7	680	500	1520	1120	2460	1820	M36 X 2	1880	1380	2960	2190	4100	3220
1-1/4" - 12	750	555	1680	1240	2730	2010							
1-3/8" - 6	890	655	1990	1470	3230	2380							
1-3/8" - 12	1010	745	2270	1670	3680	2710							
1-1/2" - 6	1180	870	2640	1950	4290	3160							
1-1/2" - 12	1330	980	2970	2190	4820	3560							

¹ in-tpi = nominal thread diameter in inches-threads per inch
² N·m = newton-meters
³ ft-lb= foot pounds
⁴ mm x pitch = nominal thread diameter in millimeters x thread pitch

Torque tolerance + 0%, -15% of torquing values. Unless otherwise specified use torque values listed above.

Warranty

Land Pride warrants to the original purchaser that this Land Pride product will be free from defects in material and workmanship beginning on the date of purchase by the end user according to the following schedule when used as intended and under normal service and conditions for personal use.

Overall Unit: One year Parts and Labor

Spikes and roller studs: Considered wear items

This Warranty is limited to the replacement of any defective part by Land Pride and the installation by the dealer of any such replacement part, and does not cover common wear items. Land Pride reserves the right to inspect any equipment or parts which are claimed to have been defective in material or workmanship.

This Warranty does not apply to any part or product which in Land Pride's judgment shall have been misused or damaged by accident or lack of normal maintenance or care, or which has been repaired or altered in a way which adversely affects its performance or reliability, or which has been used for a purpose for which the product is not designed. Misuse also specifically includes failure to properly maintain oil levels, grease points, and driveline shafts.

Claims under this Warranty should be made to the dealer which originally sold the product and all warranty adjustments must be made through an authorized Land Pride dealer. Land Pride reserves the right to make changes in materials or design of the product at any time without notice.

This Warranty shall not be interpreted to render Land Pride liable for damages of any kind, direct, consequential, or contingent to property. Furthermore, Land Pride shall not be liable for damages resulting from any cause beyond its reasonable control. This Warranty does not extend to loss of crops, any expense or loss for labor, supplies, rental machinery or for any other reason.

No other warranty of any kind whatsoever, express or implied, is made with respect to this sale; and all implied warranties of merchantability and fitness for a particular purpose which exceed the obligations set forth in this written warranty are hereby disclaimed and excluded from this sale.

This Warranty is not valid unless registered with Land Pride within 30 days from the date of purchase by the end user.

Model Number _____

Serial Number _____



Corporate Office: P.O. Box 5060
Salina, Kansas 67402-5060 USA
www.landpride.com

Free Manuals Download Website

<http://myh66.com>

<http://usermanuals.us>

<http://www.somanuals.com>

<http://www.4manuals.cc>

<http://www.manual-lib.com>

<http://www.404manual.com>

<http://www.luxmanual.com>

<http://aubethermostatmanual.com>

Golf course search by state

<http://golfingnear.com>

Email search by domain

<http://emailbydomain.com>

Auto manuals search

<http://auto.somanuals.com>

TV manuals search

<http://tv.somanuals.com>