

Flail Mower

FM20, FM30, FM31, FM40 & FM41

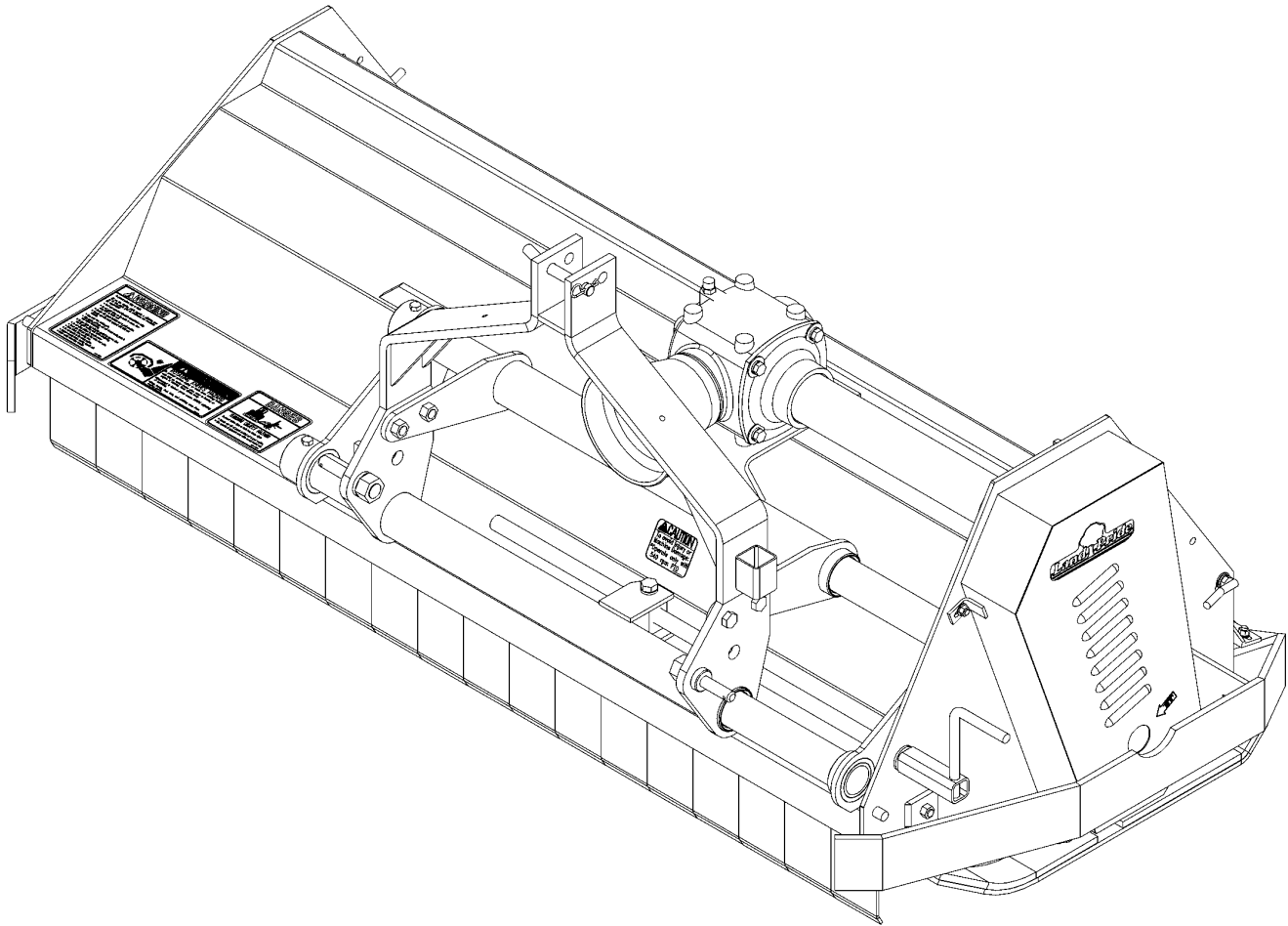

18006

309-100P **Parts Manual**



Read the Operator's manual entirely. When you see this symbol, the subsequent instructions and warnings are serious - follow without exception. Your life and the lives of others depend on it!

© Copyright 2008 Printed 02/28/08

Cover photo may show optional equipment not supplied with standard unit.





Table of Contents

Section 1: Introduction.....	4
Using This Manual.....	4
Manual Replacement Information.....	4
Manual Revisions.....	4
Touch-up Paint.....	4
Hardware Legend.....	5
Replacement Hardware.....	5
Serial Numbers.....	5
Part Number Service Coding.....	5

FM20 SERIES

Section 2: FM20 COMPONENTS.....	6
Drive.....	6
Driveline (826-277C) Eurocardan (S/N 329808-).....	8
Driveline (826-339C) Eurocardan (S/N 329809+).....	10
Frame, Hitch And Guards.....	12
Gearbox (826-287C) (S/N 329808-).....	14
Gearbox (826-338C) (S/N329809+).....	16
Label Placement.....	18
Roller And Rotor.....	20

FM30 AND FM40 SERIES

Section 3: FM30 AND FM40 COMPONENTS.....	22
Drive.....	22
Driveline (826-278C) Eurocardan.....	24
Frame, Hitch And Guards.....	26
Gearbox (826-288C) And (826-351C) With Input Clutch...28	
Gearbox (826-288C) And (826-351C) Without Clutch.....30	
Gearbox (826-352C) With Output Clutch.....	32
Gearbox (826-353C) With Output Clutch.....	34
Label Placement.....	36
Roller And Rotor.....	38

FM31 AND FM41 SERIES

Section 4: FM31 AND FM41 COMPONENTS.....	40
Drive.....	40
Driveline (826-278C) Eurocardan.....	42
Frame & Hitch.....	44
Gearbox (826-353C) With Output Clutch.....	46
Guards & Skid Shoe.....	48
Label Placement.....	50
Roller & Rotor.....	52

Part Number Index.....	54
-------------------------------	-----------

© Copyright 2008. All rights reserved.

Land Pride provides this publication "as is" without warranty of any kind, either expressed or implied. While every precaution has been taken in the preparation of this manual, Land Pride assumes no responsibility for errors or omissions. Neither is any liability assumed for damages resulting from the use of the information contained herein. Land Pride reserves the right to revise and improve its products as it sees fit. This publication describes the state of this product at the time of its publication, and may not reflect the product in the future. The illustrations in this manual are not intended for safe and proper assembly or disassembly of equipment. The illustrations are intended for ordering parts only.

Land Pride is registered trademark.

All other brands and product names are trademarks or registered trademarks of their respective holders.

Printed in the United States of America.



Alphabetized Table of Contents

FM20 SERIES

D

- Drive.....6
- Driveline (826-277C) Eurocardan (S/N 329808-).....8
- Driveline (826-339C) Eurocardan (S/N 329809+).....10

F

- Frame, Hitch And Guards.....12

G

- Gearbox (826-287C) (S/N 329808-).....14
- Gearbox (826-338C) (S/N329809+).....16

L

- Label Placement.....18

R

- Roller And Rotor.....20

L

- Label Placement.....50

R

- Roller & Rotor.....52

FM30 AND FM40 SERIES

D

- Drive.....22
- Driveline (826-278C) Eurocardan.....24

F

- Frame, Hitch And Guards.....26

G

- Gearbox (826-288C) And (826-351C) With Input Clutch.....28
- Gearbox (826-288C) And (826-351C) Without Clutch...30
- Gearbox (826-352C) With Output Clutch.....32
- Gearbox (826-353C) With Output Clutch.....34

L

- Label Placement.....36

R

- Roller And Rotor.....38

FM31 AND FM41 SERIES

D

- Drive.....40
- Driveline (826-278C) Eurocardan.....42

F

- Frame & Hitch.....44

G

- Gearbox (826-353C) With Output Clutch.....46
- Guards & Skid Shoe.....48

General Information

Using This Manual

This manual is divided into sections. The first section contains General Information. The remaining sections divide the machine into segments (i.e. Frames, Drives, Hydraulics, etc.) which illustrate and list all parts. A Parts Number Index is located at the back of the book.

The Land Pride parts in this manual are specially designed for this machine and should be replaced with Land Pride parts only.

The information in this manual is current at time of printing. Some parts may change to assure top performance.

Right-hand and left-hand as used in this manual are determined by facing the direction the machine will travel while in use.

Below is an example of two facing pages from a parts manual. Familiarize yourself with the type of information contained on these pages.

Manual Replacement Information

Replacement manuals are available. Refer to our website at www.landpride.com, the Land Pride Support Center CD or e-mail us at lit@landpride.com for additional information. Our website continues to provide the most up-to-date manuals available.

Touch-up Paint

Repaint parts where paint is worn or scratched to prevent rust. Aerosol cans and touch-up bottles with brush applicator are available through your local dealer. Land Pride color descriptions and part numbers are listed below. Also available are quart and gallon size paints. Add QT or GL to end of the Aerosol P/N.

Color	Product ¹	Aerosol	Touch-Up
Gloss Black	LP	821-032C	821-032CTU
Medium Gloss Black	UV	821-053C	821-053CTU
Beige	LP	821-011C	821-011CTU
Green	SLP	821-058C	821-058CTU
Orange	SLP	821-066C	821-066CTU
Red	SLP/UV	821-054C	821-054CTU
Blue	SLP/UV	821-067C	821-067CTU
Dark Green Sparkle	UV	821-055C	821-055CTU
Gondo Forest Green	UV	821-057C	821-057CTU
Brite Yellow ²	UV	821-056C	821-056CTU
Gondo Yellow ³	UV	821-059C	821-059CTU

Notes:

- 1 LP = All Land Pride Products except Utility Vehicles
SLP = Select Land Pride Products that are available in optional Green, Orange, Red, & Blue colors.
UV = Utility Vehicles
- 2 Used on Trekers and (Runabouts with S/N 407628-)
- 3 Used on Gondos and (Runabouts with S/N 407629+)

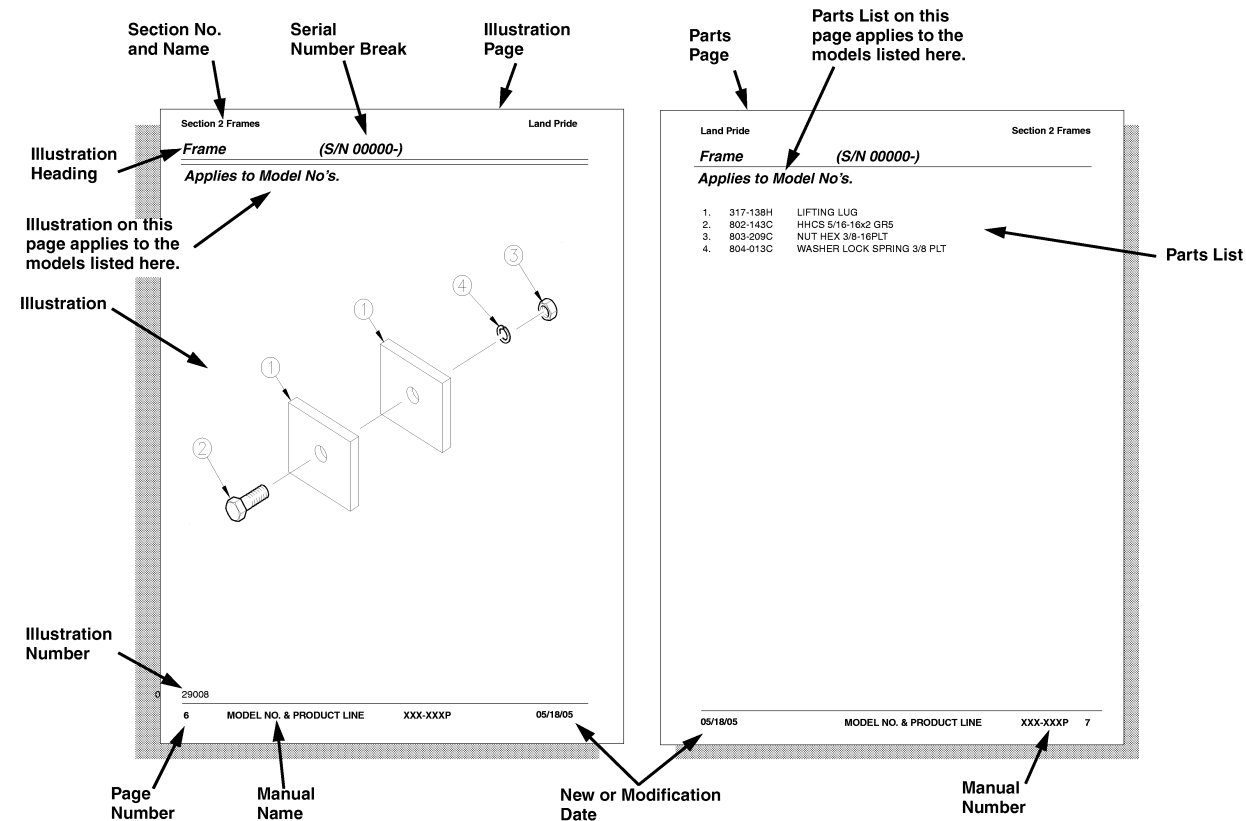

General Information

Hardware Legend

AR	As Required
BLADE	Blade Bolt
C	Cap Screw
CP	Cotter Pin
CPHSSS	Cup Point Hex Socket Set Screw
CPSHSS	Cup Point Square Head Set Screw
CPSQHSS	Cup Point Square Head Set Screw
CRFCHMS3	Cross Recess Flat Countersunk Head Machine Screw
CRPHMS	Cross Recess Pan Head Machine Screw
CRPHMFS	Cross Recess Pan Head Thread Forming
CRRHMS	Cross Recess Round Head Machine Screw
CRTHMS	Cross Recess Truss Head Machine Screw
CSNB	Countersunk Square Neck Bolt
FHMS	Flat Head Machine Screw
FTC	Full Thread Cap Screw
H	Hex Nut
HCLN	Hex Center Lock Nut
HFLCS	Hex Flange Lock Cap Screw
HFS	Hex Flange Screw
HFSLN	Hex Flange Serrated Lock Nut
HFSS	Hex Flange Serrated Screw
HHCS	Hex Head Cap Screw or Metric Bolt
HSBHCS	Hex Socket Button Head Cap Screw
HSFCHCS	Hex Socket Flat Countersunk Head Cap Screw
HSHCS	Hex Socket Head Cap Screw
HSSS	Hex Socket Head Screw
HTLN	Hex Top Lock Nut
HWHCS	Hex Washer Head Cap Screw

HWHMS	Hex Washer Head Machine Screw
HXBHCS	Hex Socket Button Head Cap Screw
J	Hex Jam Nut
JIC	37 Degree Tapered Thread
L	Helical Spring Lock Washer
LUG	Lug Bolt
NFC	National Fine Cap Screw
NPSM	National Pipe Straight Mechanical
NPTF	National Pipe Taper Fuel
P	Wide Plain Washer
PHMS	Pan Head Machine Screw
PLOW	Plow Bolt
RHMS	Round Head Machine Screw
RHSNB	Round Head Square Neck Bolt
SCREW LEVELING	Leveling Screw
SCREW THUMB	Thumb Screw
SCREW WELD	Weld Screw
SFCHMS	Slotted Flat Countersunk Head Machine Screw
SFHMS	Slotted Fillister Head Machine Screw
SP	Special
SP SCREW	Special Screw
SQHSS	Square Head Set Screw
SRHMS	Slotted Round Head Machine Screw
SSS	Socket Set Screw
STCS	Self Tapping Cap Screw
STHMS	Slotted Truss Head Machine Screw
WHEEL	Wheel Studs and Hub Long Bolts
WING	Wing Bolt

Replacement Hardware

The **Hardware Legend** above lists hardware abbreviations used in the parts list. All bolts and nuts are Grade 5 unless otherwise noted. The use of improper grades of hardware can result in personal injury, damage to equipment, or loss of property.

Colored Replacement Parts

Land Pride offers replacement parts in factory standard colors and also on select models in Green, Orange, Red and Blue. Because of the variety of colors available, special attention must be given to the part number to prevent ordering the wrong replacement part.

A suffix number corresponding to one of the colors below must be added at the end of Land Pride's part number when ordering a replacement part with that color.

81 Green 83 Red
82 Orange 84 Blue

For example, if you are ordering a replacement part with part number 555-555C and the part you need is red, then add the suffix 83 to the end of the number to make the part number read 555-555C83. Parts ordered without a suffix number will be supplied in factory standard colors.

Black Replacement Parts

Some parts are factory standard black and some must be special ordered black. If your part is special ordered black, a second part number with the additional suffix number 85 on the end will be available. In this situation you must order that part with the suffix number for it to be black. Parts that are factory standard black will not have the suffix number.

Part Number Service Coding

Within the parts list some part numbers are coded for revisions and interchangeability. See notations in revision column.

Serial Numbers

Always use the serial and model number when ordering parts. Refer to the Operator's Manual for serial number plate location.

- (S/N 20001+) Includes serial numbers 20001 and above (to the latest number)
- (S/N 10001 to 20000) Includes serial numbers between and including 10001 and 20000
- (S/N 10000-) Includes serial numbers 10000 and below (to the earliest number)

Drive

Applies to FM2060, FM2072

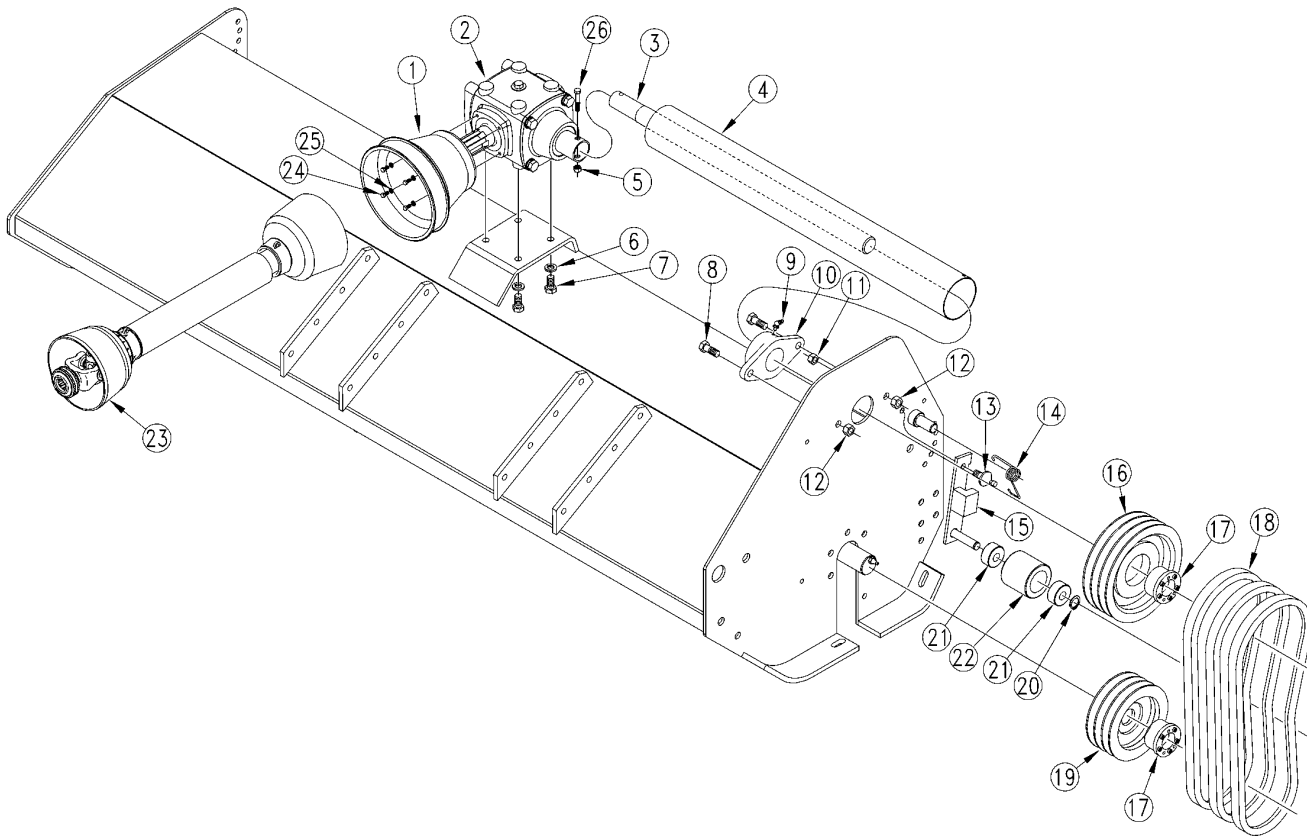

18039

Drive**Applies to FM2060, FM2072**

Ref	Part No.	Part Description	Comments	Revision
	dwg18039	Drawing Image Number		
1.	F1883510	DRIVELINE SHIELD		
2.	826-338C	GEARBOX FM20	S/N 329809+	Rev. 2
2.	826-287C	Rep By 826-338C	S/N 329808-	Rev. 1
3.	F1301129	SHAFT FM2060		
3.	F1301130	SHAFT FM2072		
4.	F5785170	PROTECTION FM2072 (31.5 LG)	60 cut to length (26 3/16)	
4.	F5785171	RPBY F5785170 (CUT TO 26 3/16)		
5.	F3667012	SELF LOCKING NUT M12		
6.	F3972012	WASHER D12 UNI 1751		
7.	F3391225	BOLT M12X1,75X25 UNI 5739		
8.	F3391440	BOLT M14X2X40 UNI 5739		
9.	F6560006	GREASE ZERK 45 DEGREE		
10.	F2020035	BEARING FYTB 35 FM 207		
11.	F3667010	SELF LOCKING NUT M10		
12.	F3560014	SELF LOCKING NUT M14		
13.	F5305017	PIN		
14.	F4211263	SPRING		
15.	F5005069	ROLLER SUPPORT		
16.	F5645153	DRIVING PULLEY 200+3 SDB F65		The inner housing of the drive pulley is tapered. When placing the Drive Pulley, you must drive a chisel into the open slot on the Hub so it can be removed.
17.	F6363565	SELF-LOCKING UNITS		
18.	F6721046	V-TYPE BELT B46	Quantity 3	
19.	F5645152	DRIVEN PULLEY 150+3 SPP F65		
20.	F6320020	SNAP RING E D20		
21.	F2226204	BEARING 6204 2RS		
22.	F5785069	BELT ADJUSTER		
23.	826-339C	DRIVELINE AX4 W/OUT CLUTCH	S/N 329809+	Rev. 2
23.	826-277C	DRIVELINE FM20 AX4 W/CLUTCH	S/N 329808-	Rev. 1
24.	F3390816	BOLT M8X1,25X16 UNI 5739		
25.	F3932008	SMOOTH WASHER D8		
26.	F3311260	BOLT TCEIM12X60X1,75		

Driveline (826-277C) Eurocardan (S/N 329808-)

Applies to FM2060, FM2072

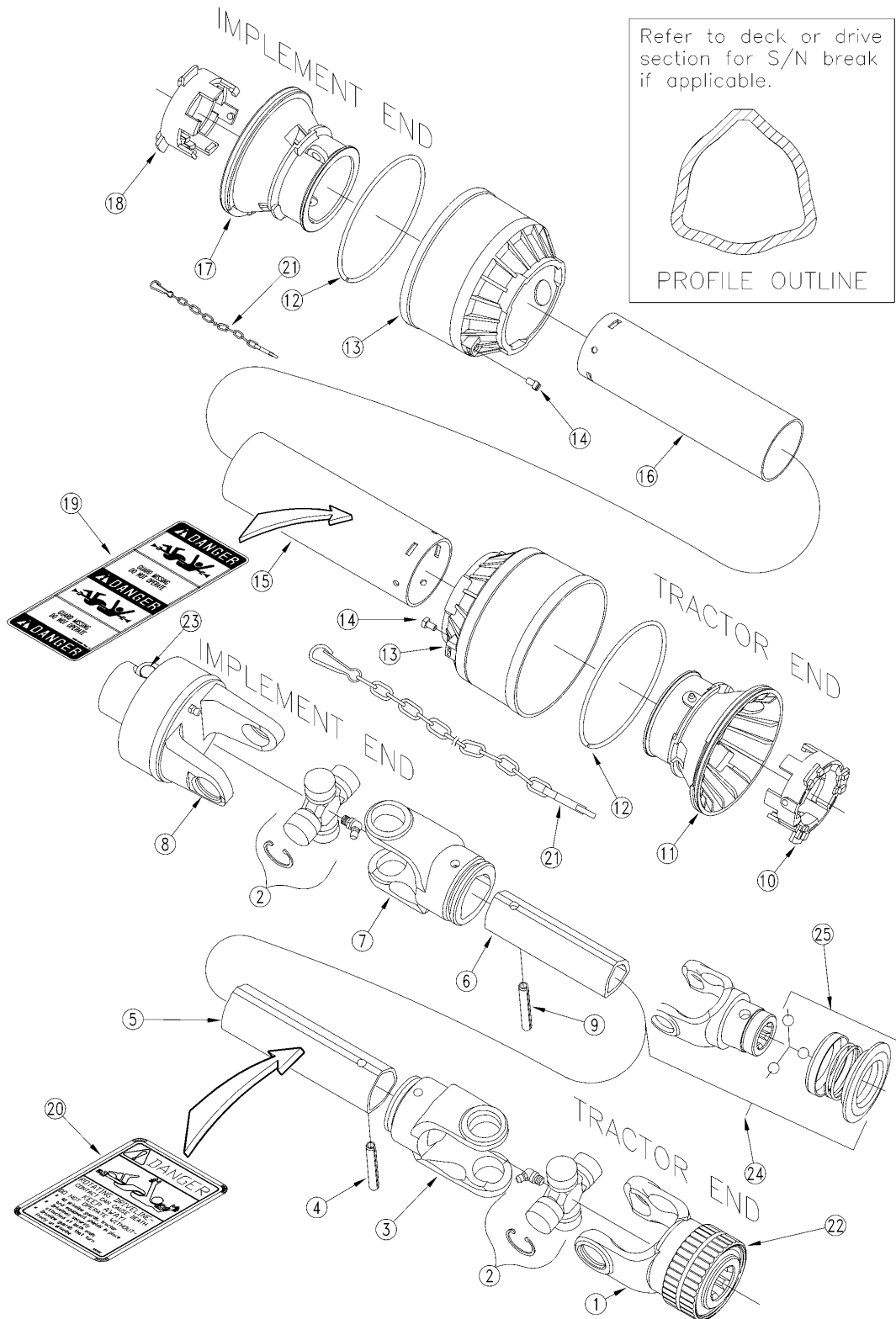

18037

Driveline (826-277C) Eurocardan (S/N 329808-)**Applies to FM2060, FM2072**

Ref	Part No.	Part Description	Comments	Revision
	dwg18037	Drawing Image Number		
	826-277C	DRIVELINE FM20 AX4 W/CLUTCH		
1.	1014010	REP BY 1014012		
2.	1004020	EC CROSS ASSEMBLY (U JOINT)		
3.	1704027	EC OUTER TUBE YOKE		
4.	6330860	EC 08X60 1485DIN ROLL PIN		
5.	1524046	EC OUTER TUBE (1524062) 460MM		
6.	1525046	EC INNER TUBE (1525062) 460MM		
7.	1704029	EC INNER TUBE YOKE		
8.	1504226	EC SAFTY DEVICE: FREE WHEEL		
9.	6330855	EC 8X55-DIN-1481 O/TUBE R/PIN		
10.	1784210	EC TUBE BEARING		
11.	1884201	EC OUTER TUBE RIGID CONE		
12.	1213233	EC STIFFENING RING		
13.	1884203	EC SOFT CONE		
14.	1784212	EC PIN STOP ROTATION		
15.	1873038	EC OUTER TUBE (1873050) 380MM		
16.	1872038	EC INNER TUBE (1872050) 380MM		
17.	1884202	EC INNER TUBE RIGID CONE		
18.	1784211	EC TUBE BEARING		
19.	818-540C	DECAL DANGER GUARD MISS PTO		
20.	818-552C	DECAL DANGER PTO DRIVELINE		
21.	044321	DRIVELINE SHIELD SAFETY CHAIN		
22.	1004220	EC TWIST COLLAR KIT (TRT. END)		
23.	1581038	EC COMPLETE PUSH-PIN KIT		
24.	1014012	EC YOKE ASSEMBLY		
25.	1004225	EC PULL COLLAR KIT		

Driveline (826-339C) Eurocardan (S/N 329809+)

Applies to FM2060, FM2072

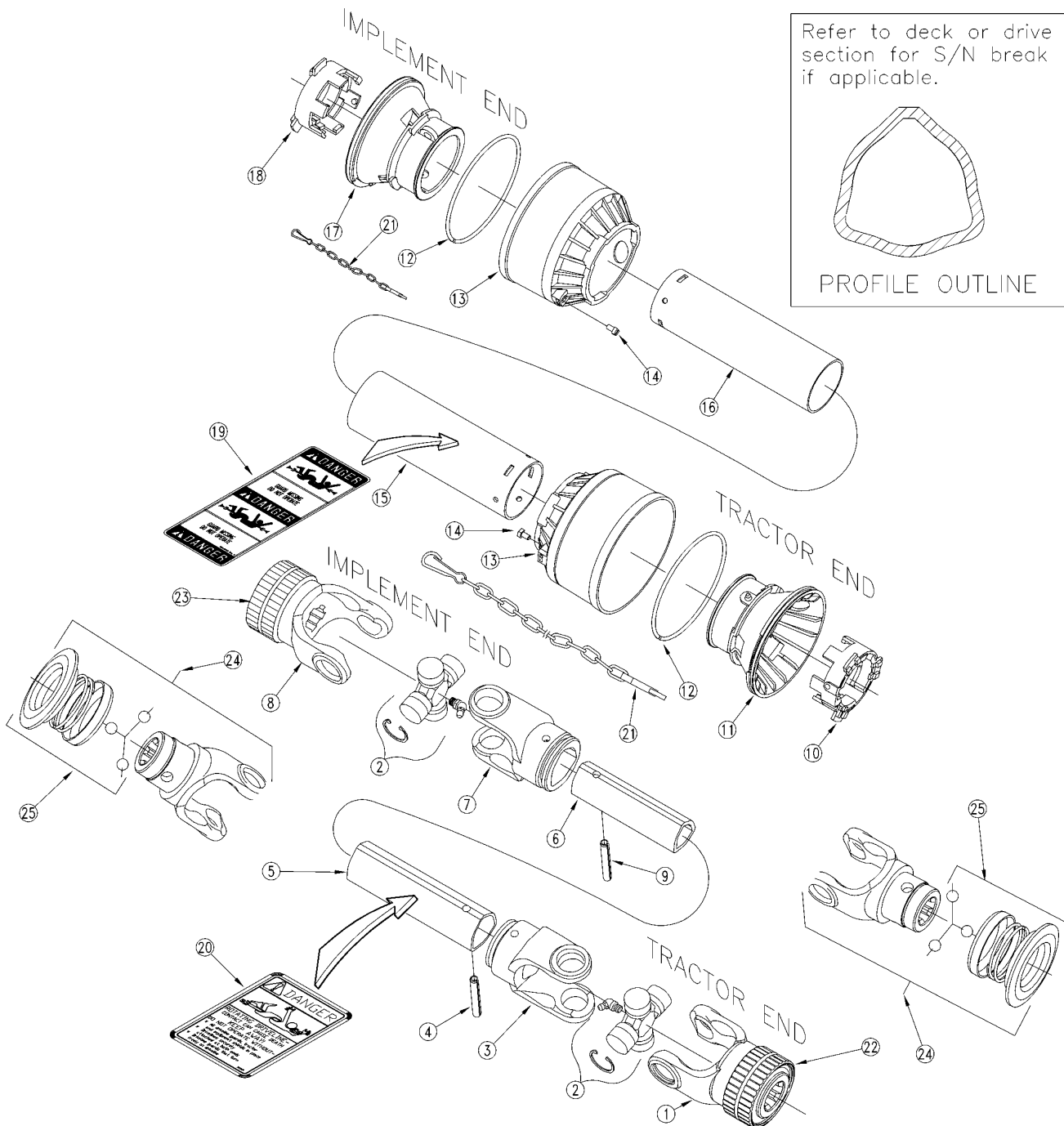

Driveline (826-339C) Eurocardan (S/N 329809+)**Applies to FM2060, FM2072**

Ref	Part No.	Part Description	Comments	Revision
	dwg19600	Drawing Image Number		
	826-339C	DRIVELINE AX4 W/OUT CLUTCH *		
1.	1014010	REP BY 1014012		
2.	1004020	EC CROSS ASSEMBLY (U JOINT)		
3.	1704027	EC OUTER TUBE YOKE		
4.	6330860	EC 08X60 1485DIN ROLL PIN		
5.	1524046	EC OUTER TUBE (1524062) 460MM		
6.	1525046	EC INNER TUBE (1525095) 460MM		
7.	1704029	EC INNER TUBE YOKE		
8.	1114010	REP BY 1014012		
9.	6330855	EC 8X55-DIN-1481 O/TUBE R/PIN		
10.	1784210	EC TUBE BEARING		
11.	1884201	EC OUTER TUBE RIGID CONE		
12.	1213233	EC STIFFENING RING		
13.	1884203	EC SOFT CONE		
14.	1784212	EC PIN STOP ROTATION		
15.	1873038	EC OUTER TUBE (1873050) 380MM		
16.	1872038	EC INNER TUBE (1872050) 380MM		
17.	1884202	EC INNER TUBE RIGID CONE		
18.	1784211	EC TUBE BEARING		
19.	818-552C	DECAL DANGER PTO DRIVELINE		Rev. 2
19.	1140001	REP BY 818-552C		Rev 1; Use up stock
20.	818-540C	DECAL DANGER GUARD MISS PTO		Rev. 2
20.	1140003	REP BY 818-540C		Rev 1; Use up stock
21.	044321	DRIVELINE SHIELD SAFETY CHAIN		Rev. 2
21.	1006065	REP BY 044321		Rev 1; Use up stock
22.	1004220	EC TWIST COLLAR KIT (TRT. END)		
23.	1004224	EC TWIST COLLAR KIT (IMP. END)		
24.	1014012	EC YOKE ASSEMBLY		
25.	1004225	EC PULL COLLAR KIT		

Frame, Hitch And Guards

Applies to FM2060, FM2072

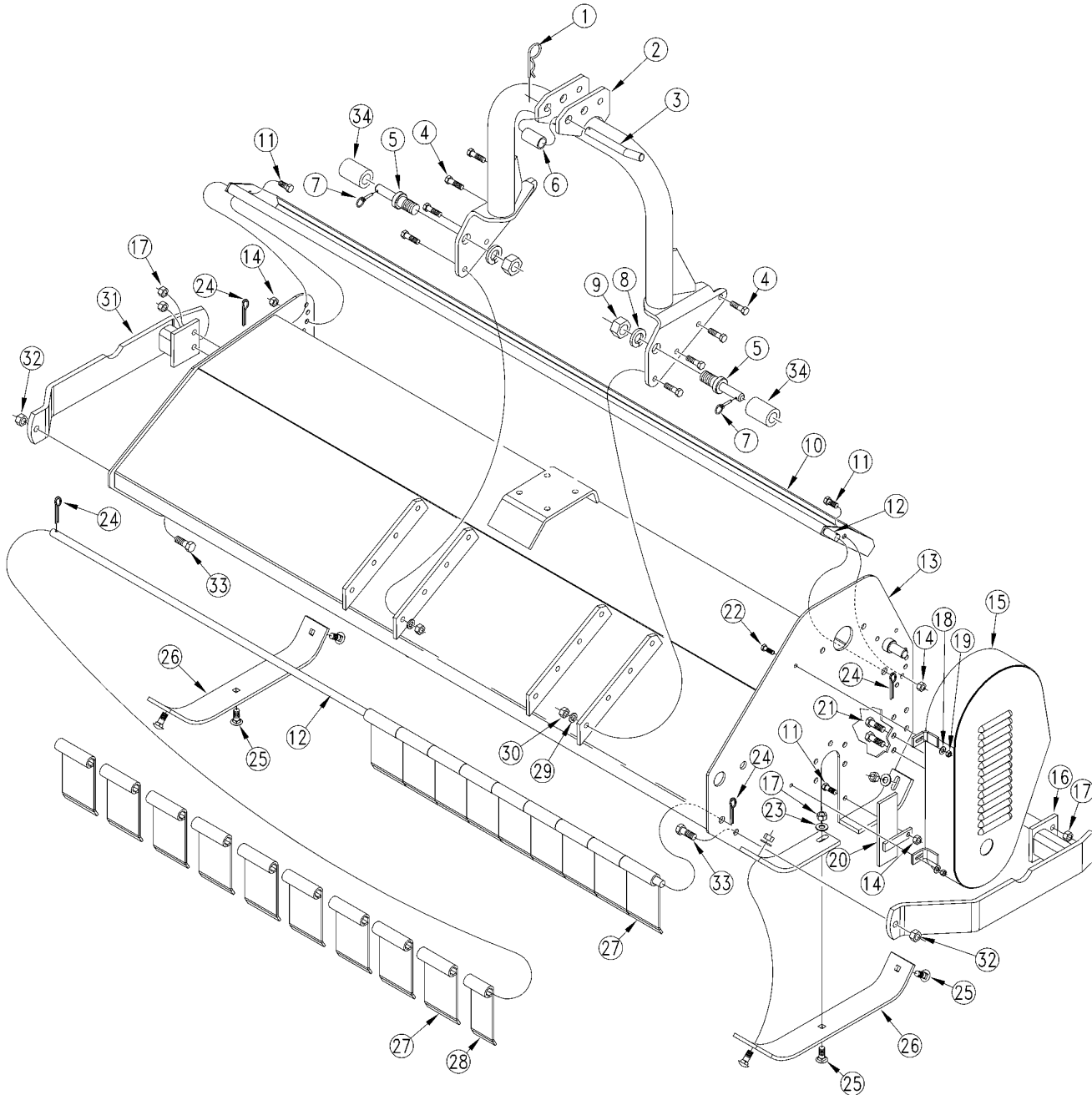

18036

Frame, Hitch And Guards**Applies to FM2060, FM2072**

Ref	Part No.	Part Description	Comments	Revision
	dwg18036	Drawing Image Number		
1.	F6351004	PIN HAIR COTTER D4		
2.	F5005062	FM20 HITCH		
3.	F4301589	UPPER HITCH PIN		
4.	F3391225	BOLT M12X1,75X25 UNI 5739		
5.	F4208227	LOWER HITCH PIN		
6.	F5532111	3RD POINT SPACER		
7.	F6350010	LINCH PIN D10		
8.	F3972024	WASHER D24 UNI 1751		
9.	F3540024	NUT M24 P.F. UNI 5587		
10.	F5005025	REAR DEFLECTOR FM2072		
10.	F5005024	REAR DEFLECTOR FM2060		
11.	F3391025	BOLT M10X1,5X25 UNI 5739		
12.	F5235158	PIN FM2060		
12.	F5235159	PIN FM2072		
13.	F5005046	FRAME FM2060		
13.	F5005067	FRAME FM2072		
14.	F3667010	SELF LOCKING NUT M10		
15.	F5005009	GUARD		
16.	F5005005	BELT GUARD SHIELD LH		
17.	F3667012	SELF LOCKING NUT M12		
18.	F3930008	WASHER D8 UNI 1734		
19.	F3560008	NUT M8 P.G. UNI 5587		
20.	F5005133	PROTECTION		
21.	F3391240	SHIELD BOLT M12X40X1,75		
22.	F3390825	BOLT M8X1,25X25 UNI 5739		
23.	F3930012	WASHER D12 UNI 1734		
24.	F6330540	COTTER PIN D5X40		
25.	F3201235	SPECIAL BOLT M12X35X1,75		
26.	F5805001	SKID SHOE		
27.	F5136608	DEFLECTOR		
28.	F5136609	FRONT DEFLECTOR NARROW		
29.	F3972012	WASHER D12 UNI 1751		
30.	F3560012	NUT M12 P.G. UNI 5587		
31.	F5005006	SHIELD RH		
32.	F3667014	SELF LOCKING NUT M14		
33.	F3391440	BOLT M14X2X40 UNI 5739		
34.	F5532111	3RD POINT SPACER		

Gearbox (826-287C) (S/N 329808-)

Applies to FM2060, FM2072

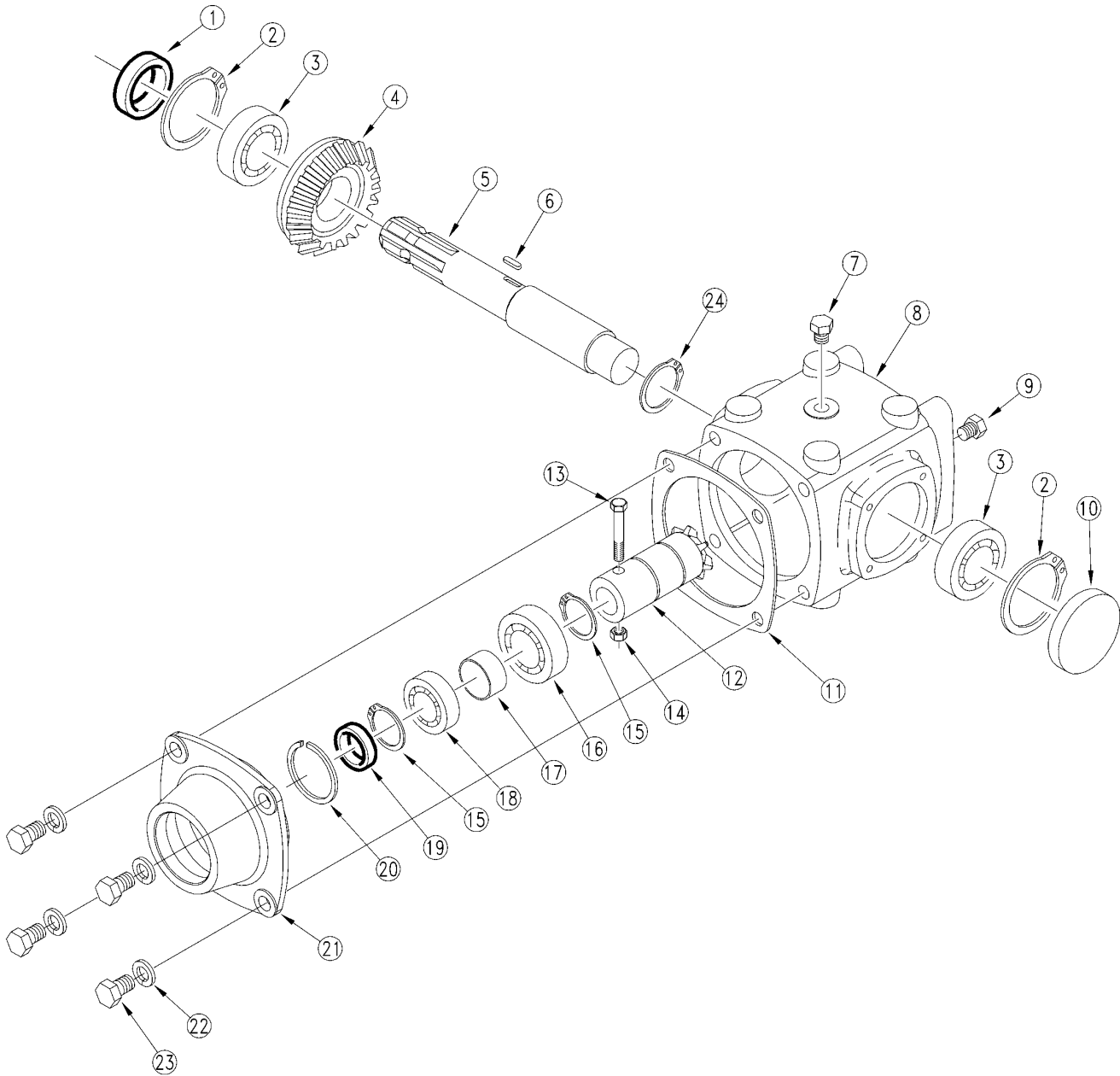

18035

Gearbox (826-287C) (S/N 329808-)**Applies to FM2060, FM2072**

Ref	Part No.	Part Description	Comments	Revision
	dwg18035	Drawing Image Number		
	826-287C	GBOX FM20		
1.	F6203572	OIL SEAL 35X72X10 P.P.		
2.	F6310072	SNAP RING 1 O 72		
3.	822-166C	BEARING BALL 6207		Rev. 2
3.	F2106207	RPBY 822-166C		Rev 1; Use up stock
4.	309-060A	RING BEVEL GEAR Z34 KIT		Rev. 3
4.	F1721103	RPBY 309-060A		Rev. 2
4.	F1721104	RPBY F1721103		Rev. 1
5.	F1221104	SHAFT		
6.	F6361030	KEY 10X8X30		
7.	F3442018	PLUG PRESSURE RELIEF		
8.	F1641101	GEARBOX HOUSING		
9.	F3441018	BEVEL PLUG 18X1,5		
10.	F6100072	COVER 0 72		
11.	F1781107	SEAL C/C EC-30		
12.	F1221103	BEVEL PINION Z=12		
13.	F3311260	BOLT TCEIM12X60X1,75		
14.	F3667012	SELF LOCKING NUT M12		
15.	F6320045	SNAP RING E D45		
16.	F2106209	BEARING 6209		
17.	F1531106	SPACER		
18.	F2106009	BEARING 6009		
19.	F6204562	OIL SEAL D45X62X10 P.P		
20.	F6310085	SNAP RINGI D85		
21.	F1701105	COVER		
22.	F3972012	WASHER D12 UNI 1751		
23.	F3391220	BOLT M12 75X20 UNI 5739		Rev. 1
24.	F6320042	CIRCLIP E 42mm DIA		

Gearbox (826-338C) (S/N329809+)

Applies to FM2060, FM2072

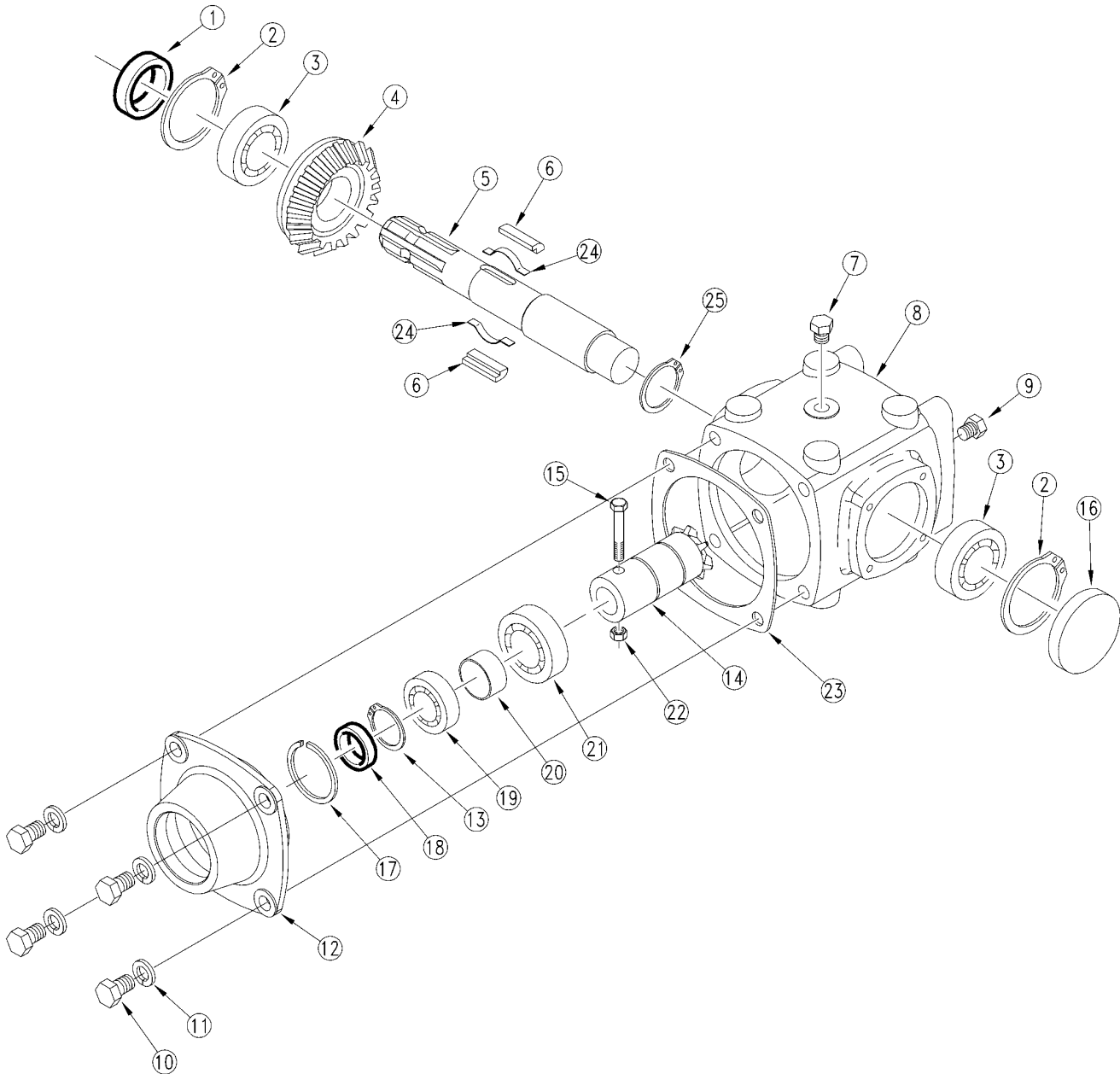

22312

Gearbox (826-338C) (S/N329809+)**Applies to FM2060, FM2072**

Ref	Part No.	Part Description	Comments	Revision
	dwg22312	Drawing Image Number		
1.	826-338C	GEARBOX FM20		
1.	F6203572	RPBY 6203572		
2.	F6310072	SNAP RING 1 O 72		
3.	F2106207	REP BY 822-166C		
4.	F1721109	RING BEVEL GEAR +RL Z-30		
4.	F1721105	RING BEVEL GEAR + RL Z-34		
5.	F1221107	SAFT + RL		
6.	F1321001	PAWL		
7.	F3442018	PLUG		
8.	F1641101	GEARBOX HOUSING		
9.	F3441018	PLUG PRESSURE RELIEF		
10.	F3391225	BOLT M12X1,75X25 UNI 5739		
11.	F3972012	WASHER D12 UNI 1751		
12.	F1701105	COVER		
13.	F6320045	SNAP RING E D45		
14.	F1221109	BEVEL PINION Z-11		
14.	F1221103	BEVEL PINION Z=12		
15.	F3311260	BOLT TCEIM12X60X1,75		
16.	F6100072	COVER 0 72		
17.	F6310085	SNAP RING I D85		
18.	F6204562	OIL SEAL D45X62X10 P.P		
19.	F2106009	BEARING 6009		
20.	F1531106	SPACER		
21.	F2106209	BEARING 6209		
22.	803-281C	NUT HEX NYLOCK M12X1.75 PLT		
23.	F1781107	SEAL C/C EC-30		
24.	F1811001	FLAT SPRING		
25.	F6320042	CIRCLIP E 42mm DIA		

Label Placement

Applies to FM2060, FM2072

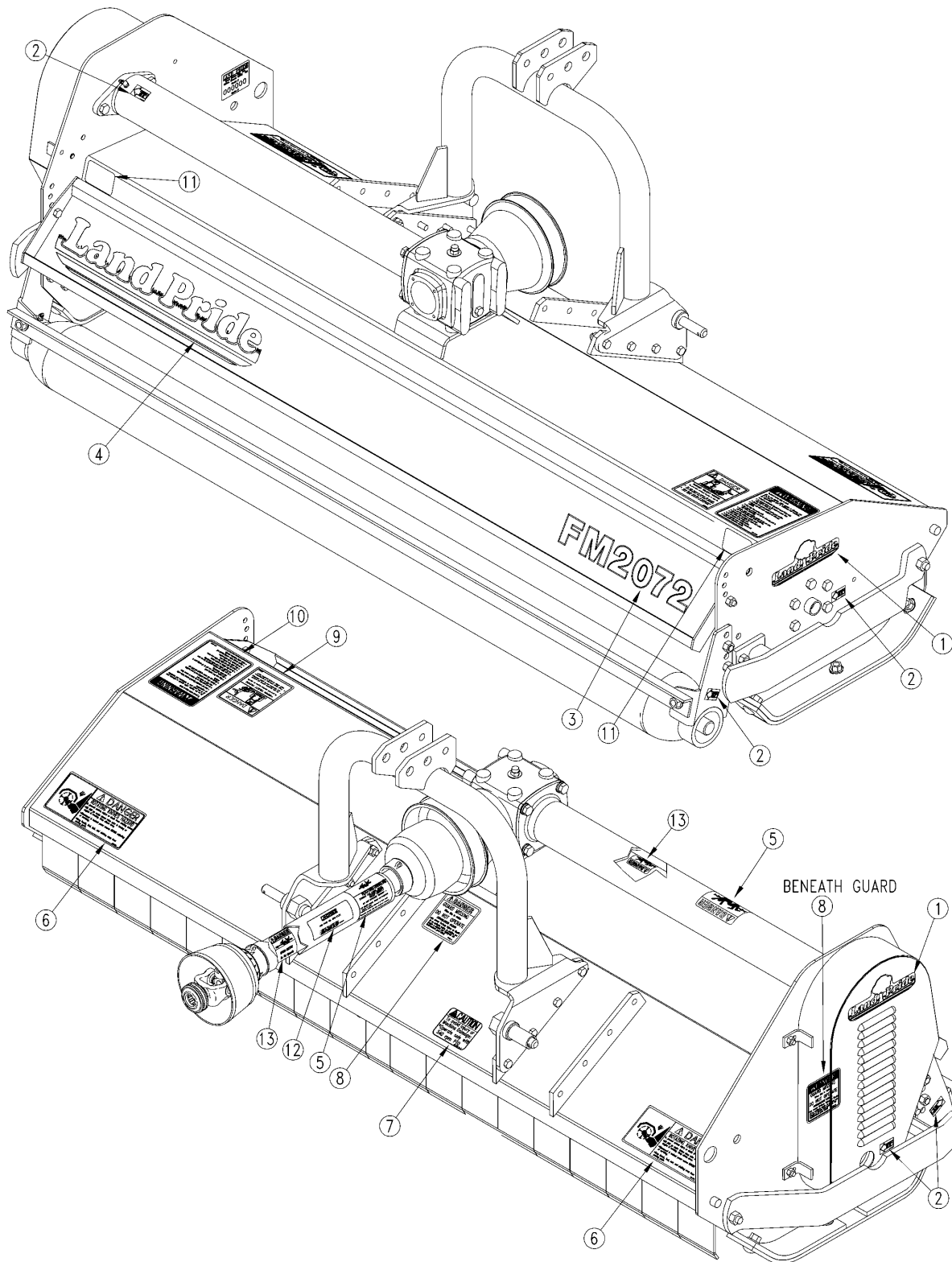

18040

Label Placement**Applies to FM2060, FM2072**

Ref	Part No.	Part Description	Comments	Revision
	dwg18040	Drawing Image Number		
	309-101A	FM2060 DECAL PACKAGE		
	309-102A	FM2072 DECAL PACKAGE		
1.	818-896C	DECAL LP W/TREE 6" - 2 COLOR		
2.	818-138C	DECAL GREASE EVERY 25 HOURS		
2.	838-070C	DECAL FM2060-BROWN		
3.	838-071C	DECAL FM2072-BROWN		
4.	818-903C	DECAL LANDPRIDE 19" - BROWN		
5.	818-552C	DECAL DANGER PTO DRIVELINE		
6.	838-079C	DECAL DANGER ROTATING KNIVES		
7.	818-130C	DECAL CAUTION 540 RPM		
8.	818-543C	DECAL DANGER PD GUARD MISS SML		
9.	818-556C	DECAL DANGER THROWN OBJ CUTTER		
10.	818-558C	DECAL WARNING GEN SAFE MOWER		
11.	818-230C	DECAL RED REFLECTOR		
12.	838-682C	DECAL PTO 826-339C	(S/N +)	Rev. 2
12.	838-082C	RPBY 838-682C	(S/N -)	Rev. 1
13.	818-540C	DECAL DANGER GUARD MISS PTO		

Roller And Rotor

Applies to FM2060, FM2072

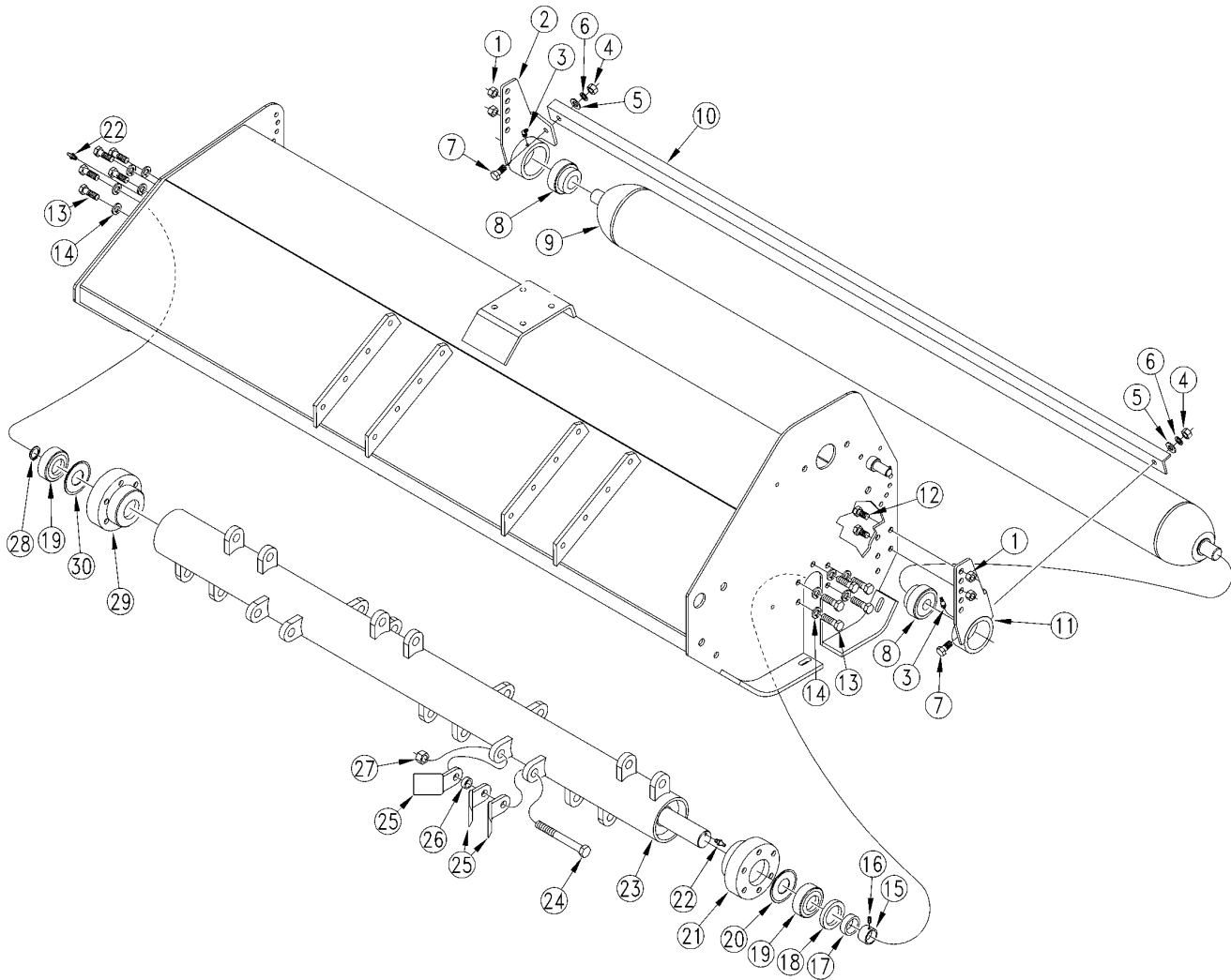

18038

Roller And Rotor

Applies to FM2060, FM2072

Ref	Part No.	Part Description	Comments	Revision
	dwg18038	Drawing Image Number		
1.	F3667012	SELF LOCKING NUT M12		
2.	F5005010	RIGHT ROLLER SUPPORT		
3.	F6560008	GREASE ZERK M8X1,25		
4.	F3560012	NUT M12 P.G. UNI 5587		
5.	F3930012	WASHER D12 UNI 1734		
6.	F3972012	WASHER D12 UNI 1751		
7.	802-458C	HHCS M12X1.75X30 GR8.8		
8.	F2030030	BEARING YAR 206 - 2 RF		
9.	F5005017	STABILIZER ROLLER FM2060		
9.	F5005018	STABILIZER ROLLER FM2072		
10.	F5865004	SCRAPER FM2060		
10.	F5865005	SCRAPER FM2072		
11.	F5005011	LEFT ROLLER SUPPORT		
12.	802-613C	HHCS M12X1.75X35 GR8.8		
13.	F3391225	BOLT M12X1,75X25 UNI 5739		
14.	F3950012	WASHER D12 UNI 6798		
15.	F5535159	SPACER		
16.	F3270610	BOLT M6X10 UNI 5927		
17.	F6204562	OIL SEAL D45X62X10 P.P		
18.	F5595160	METAL RING		
19.	F2822207	BEARING 22207	Rotor must be disassembled when replacing bearings. It is recommended to replace both bearings at once.	
20.	F2122207	SEAL 22207/JV		
21.	F5705152	SUPPORT		
22.	F6560008	GREASE ZERK M 8		
23.	F5005169C	FM2060 ROTOR W/Y-BLADES		
23.	F5005170C	ROTOR WITH Y-BLADES FOR FM2072		
24.	F3371690	BOLT M16X2X90 UNI 5737		
25.	F5815160	Y BLADE	FM2060 Quantity 60; FM2072 Quantity 72	
26.	F5536626	KNIFE SPACER		
27.	F3667016	SELF LOCKING NUT M16 PG		
28.	F6320035	SNAP RING E D35		
29.	F5705153	SUPPORT		
30.	F2022207	SEAL 22207/AV		

Drive

Applies to FM3072, FM3088, FM4088

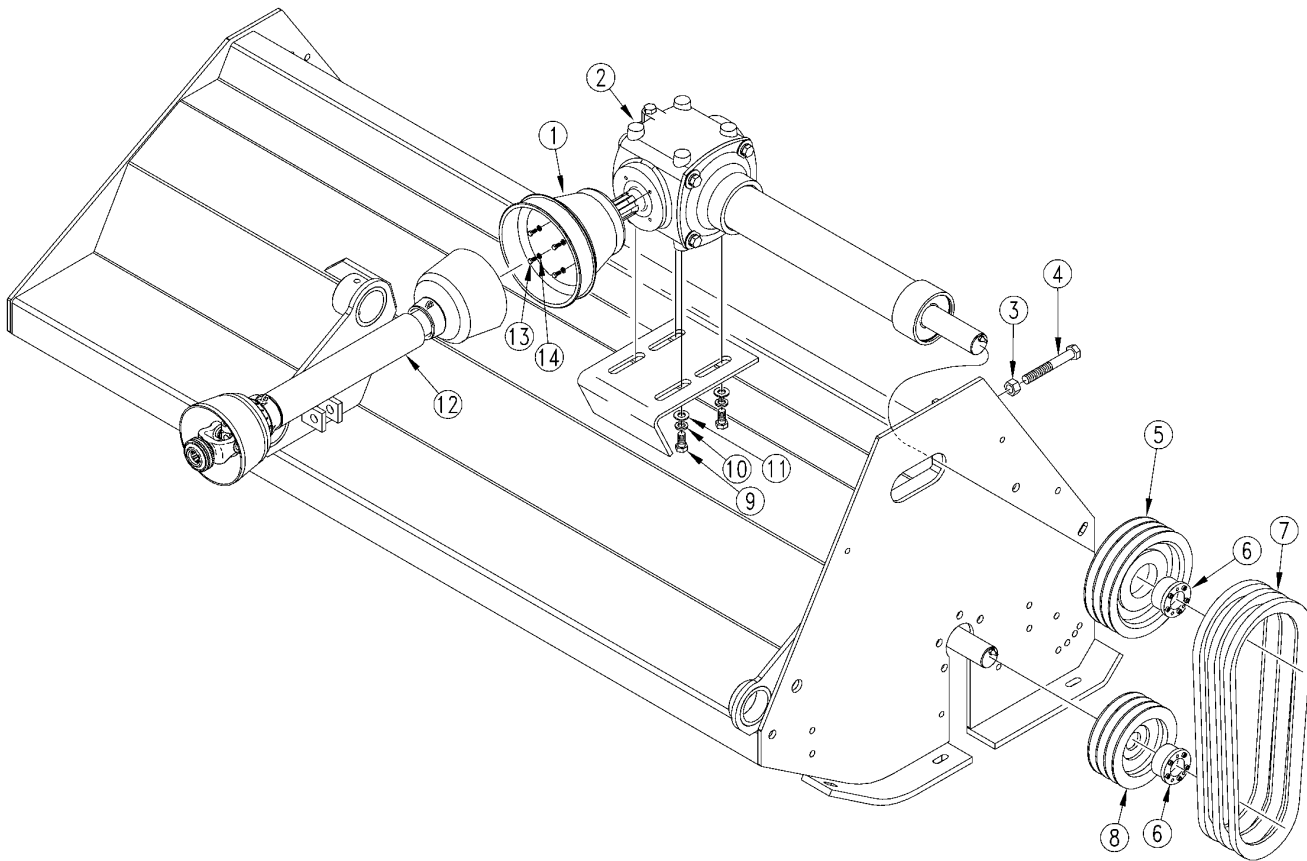

Drive

Applies to FM3072, FM3088, FM4088

Ref	Part No.	Part Description	Comments	Revision
	dwg18061	Drawing Image Number		
1.	F1883510	DRIVELINE SHIELD		
2.	826-352C	GBOX FM3072 W/CLUTCH	S/N 340867+	Rev. 2
2.	826-288C	REP BY 826-352C	S/N 340866-	Rev. 1
2.	826-353C	GBOX FM3088/FM4088 W/CLUTCH		Rev. 2
2.	826-351C	REP BY 826-353C		Rev. 1
3.	F3560016	NUT M16 P.G. UNI 5587		
4.	F3391612	BOLT M16X2X120 UNI 5739		
5.	F5646333	DRIVING PULLEY DP-225 3C		
6.	F6364080	SELF-LOCKING UNITS		
7.	F6730056	V-TYPE BELT C 56	Quantity 3	
8.	F5646332	DRIVEN PULLEY DP 190 3C		
9.	F3391635	BOLT M16X2X35 UNI 5739		
10.	F3972016	WASHER D16 UNI 1751		
11.	F3932016	SMOOTH WASHER D16 UNI 6592		
12.	826-278C	DRIVELINE FM30/40 AX6 NOCLUTCH		
13.	F3390816	BOLT TCEIM12X60X1,75		
14.	F3932008	SMOOTH WASHER D8		

Driveline (826-278C) Eurocardan

Applies to FM3072, FM3088, FM4088

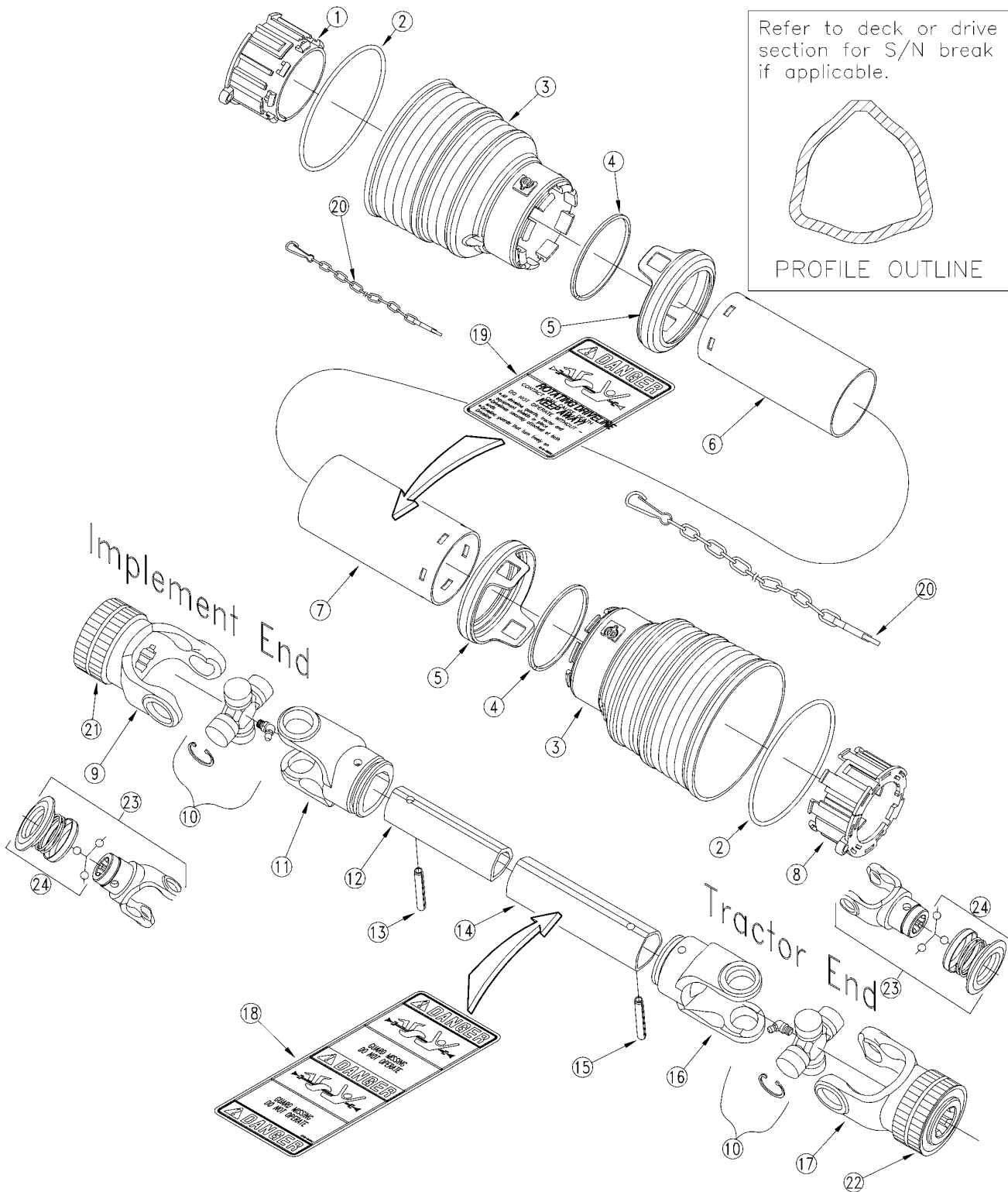

18064

Driveline (826-278C) Eurocardan**Applies to FM3072, FM3088, FM4088**

Ref	Part No.	Part Description	Comments	Revision
	dwg18064	Drawing Image Number		
	826-278C	DRIVELINE FM30/40 AX6 NOCLUTCH		
1.	1786711	EC TUBE BEARING (INNER TUBE)		
2.	1215733	EC STIFFENING RING		
3.	1885703	EC STANDARD CONE		
4.	1215735	EC STOP RING		
5.	1885709	EC SAFETY SLEEVE		
6.	1877054	EC INNER TUBE (1877094) 540MM		
7.	1876054	EC OUTER TUBE (1876094) 540MM		
8.	1786710	EC TUBE BEARING (OUTER TUBE)		
9.	1116010	EC YOKE ASSY 1 3/8-6(IMP. END)		
10.	1006020	EC CROSS ASSEMBLY		
11.	1706029	EC INNER TUBE YOKE		
12.	1526064	EC INNER TUBE (1526084) 640MM		
13.	6331070	EC 10X70 ROLL PIN		
14.	1528064	EC OUTER TUBE (1528084) 640MM		
15.	6331080	EC 10X80-DIN-1481 O/TUBE R/PIN		
16.	1706027	EC OUTER TUBE YOKE		
17.	1016010	EC YOKE ASSEMBLY (TRACT. END)		
18.	818-540C	DECAL DANGER GUARD MISS PTO		
19.	818-552C	DECAL DANGER PTO DRIVELINE		
20.	044321	DRIVELINE SHIELD SAFETY CHAIN		
21.	1004224	EC TWIST COLLAR KIT (IMP. END)		
22.	1004220	EC TWIST COLLAR KIT (TRT. END)		
23.	1016013	EC YOKE ASSEMBLY		
24.	1004227	EC PULL COLLAR KIT EVOLUTION		

Frame, Hitch And Guards

Applies to FM3072, FM3088, FM4088

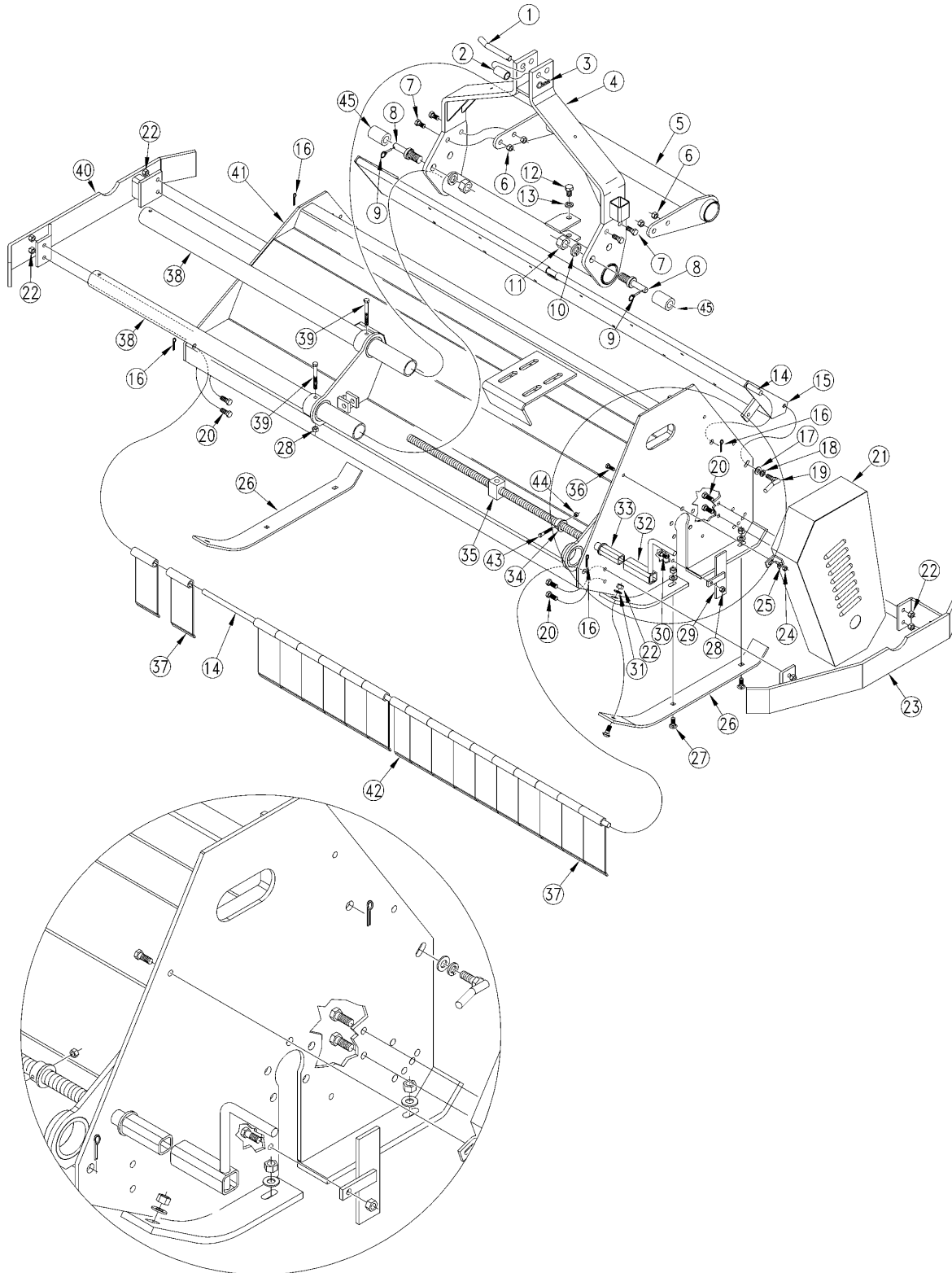

18060

Frame, Hitch And Guards**Applies to FM3072, FM3088, FM4088**

Ref	Part No.	Part Description	Comments	Revision
	dwg18060	Drawing Image Number		
1.	F4301591	3RD POINT PIN		
2.	F5532112	3RD POINT SPACER		
3.	F6351004	PIN HAIR COTTER D4		
4.	F5005610	HITCH		
5.	F5005611	CONNECTING PLATE PIPE		
6.	F3667016	SELF LOCKING NUT M16 PG		
7.	F3371650	BOLT M16X2X50 UNI 5737		
8.	F4208227	LOWER HITCH PIN		
9.	F6350010	LINCH PIN D10		
10.	F3972024	WASHER D24 UNI 1751		
11.	F3540024	NUT M24 P.F. UNI 5587		
12.	F3391625	BOLT M16X2X25 UNI 5739		
13.	F3972016	WASHER D16 UNI 1751		
14.	F5236615	PIN FM3072		
14.	F5236616	PIN FM30-4088		
15.	F5006522	REAR DEFLECTOR FM3072		
15.	F5006523	REAR DEFLECTOR FM3088/4088		
16.	F6330540	COTTER PIN D5X50		
17.	F3932012	SMOOTH WASHER D12 UNI 6592		
18.	F3972012	WASHER D12 UNI 1751		
19.	F5006532	COVER ADJUSTING PIN		
20.	F3391240	SHIELD BOLT M12X40X1,75		
21.	F5006304	BELT GUARD SHIELD LH		
22.	F3667012	SELF LOCKING NUT M12		
23.	F5006513	BELT GUARD SHIELD LH		
24.	F3667008	SELF LOCKING NUT M8		
25.	F3930008	WASHER D8 UNI 1734		
26.	F5806500	SKID SHOE		
27.	F3201235	SPECIAL BOLT M12X35X1,75		
28.	F3667010	SELF LOCKING NUT M10		
29.	F5006565	PROTECTION		
30.	F3371090	BOLT M10X1,5X90 UNI 5737		
31.	F3930012	WASHER D12 UNI 1734		
32.	F4002235	ADJUSTMENT HANDLE		
33.	F5006323	ADJUSTMENT SCREW		
34.	F5206324	BUSHING		
35.	F5336326	COUPLING		
36.	F3390825	BOLT M8X1,25X25 UNI 5739		
37.	F5136608	DEFLECTOR		
38.	F5595609	GUIDE TUBE		
39.	F3371090	BOLT M10X1,5X90 UNI 5737		
40.	F5006514	SHIELD RH		
41.	F5006518	FRAME 3072		
41.	F5006519	FRAME 30-4088		
42.	F5136609	FRONT DEFLECTOR NARROW		
43.	F3370660	BOLT M6X1X60 UNI 5737		
44.	F3667006	SELF LOCKING NUT M 6 PG		
45.	F5532111	3RD POINT SPACER		

Gearbox (826-288C) And (826-351C) With Input Clutch

Applies to FM3072, FM3088, FM4088

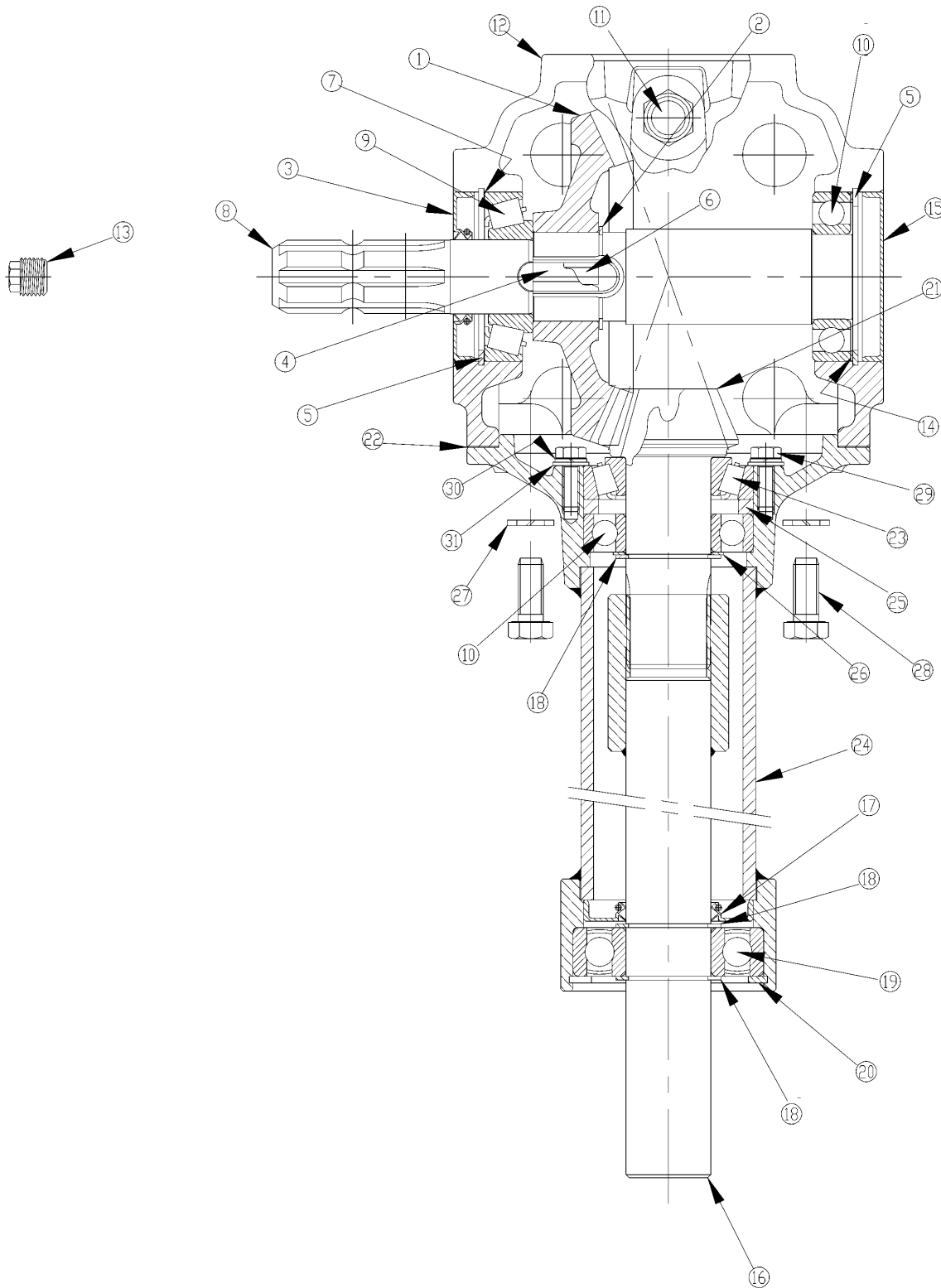

Gearbox (826-288C) And (826-351C) With Input Clutch**Applies to FM3072, FM3088, FM4088**

Ref	Part No.	Part Description	Comments	Revision
	dwg22431	Drawing Image Number		
	826-288C	RPBY 826-352C		
	826-351C	RPBY 826-353C		
		*		
1.	F1721009	RING BEVEL GEAR		
2.	F6320042	CIRCLIP E 42mm DIA		
3.	F6103580	EC SEAL		
4.	F1321001	PAWL		
5.	F6310080	SNAP RING I D80		
6.	F1811001	FLAT SPRING		
7.	F6016502	SHIM		
8.	F1221003	SHAFT W/OVERRUN CLUTCH		
9.	F2030307	EC CONICAL BEARING 30307		
10.	F2006208	BEARING 6208		
11.	F3442018	PLUG PRESSURE RELIEF		
12.	F1641001	GEARBOX EC-60 HOUSING		
13.	F3441018	BEVEL PLUG 18X1,5		
14.	F6016502	SHIM		
15.	F6100080	COVER		
16.	F1001060	EXTENSION FM3072	826-288C	
16.	F1001062	EXTENSION FM 30/4088	826-351C	
17.	F6204080	OIL SEAL 40X80X10 DBL LIP		
17.	F6104080	RPBY F6204080		
18.	F6320040	SNAP RING E D40		
19.	F2236308	BEARING 6308 2RS		
20.	F6310090	SNAP RING I D90		
21.	F1721007	PINION		
22.	F1781041	GASKET		
23.	F2030208	BEARING 30208		
24.	F1001016	SHAFT FM3072	826-288C	
24.	F1001018	SHAFT FM 30/4088	826-351C	
25.	F1591042	SPACER		
26.	F6014005	SHIM		
27.	F3971012	WASHER D12 UNI 1751		
28.	802-458C	HHCS M12X1.75X30 GR8.8		Rev. 2
28.	F3391230	REP BY 802-458C		Rev 1; Use up stock
29.	F3390825	BOLT M8X1,25X25 UNI 5739		
30.	F3971008	EC WASHER D8 UNI 1751		
31.	F3930008	WASHER D8 UNI 1734		

Gearbox (826-288C) And (826-351C) Without Clutch

Applies to FM3072, FM3088, FM4088

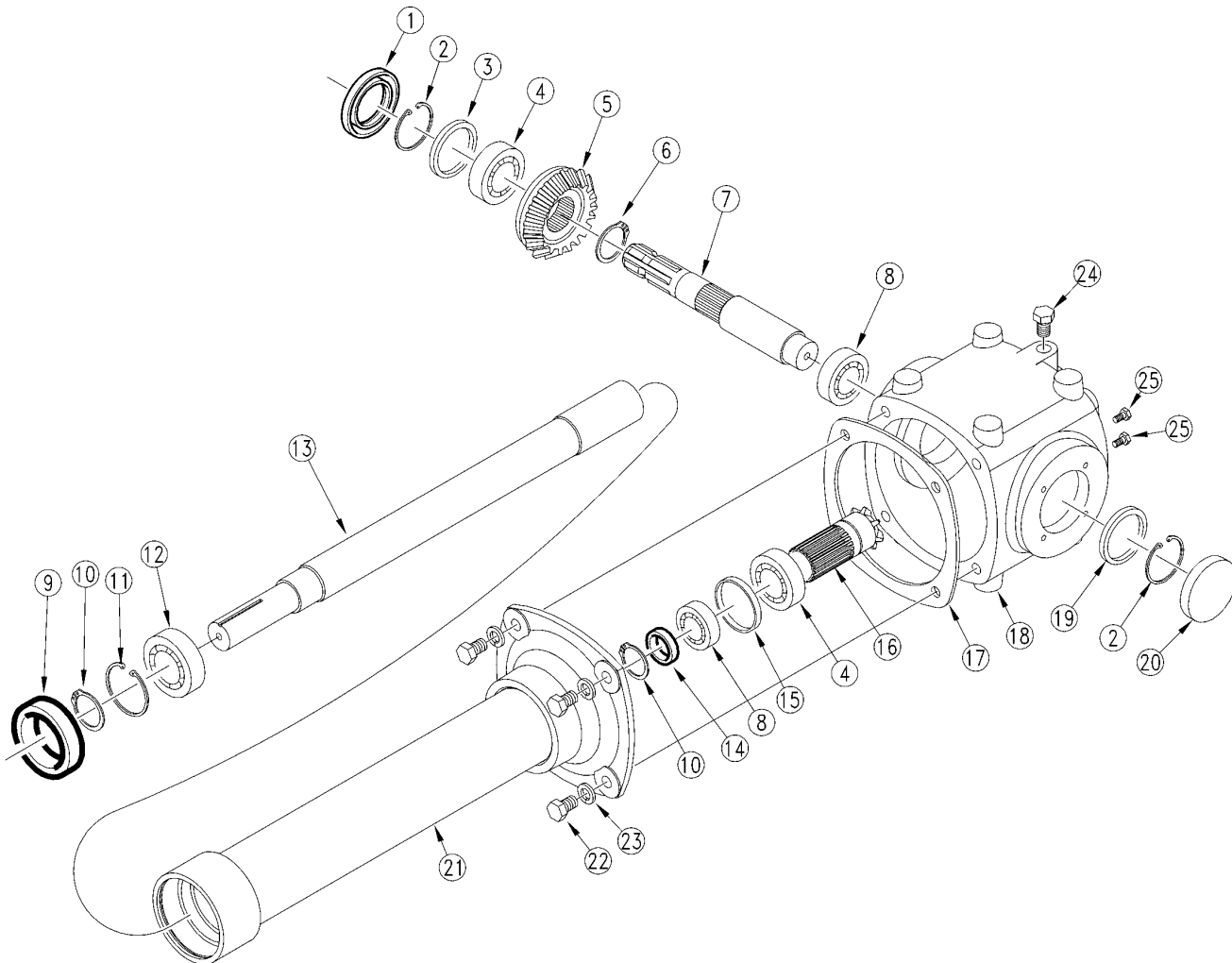

18063

Gearbox (826-288C) And (826-351C) Without Clutch**Applies to FM3072, FM3088, FM4088**

Ref	Part No.	Part Description	Comments	Revision
	dwg18063	Drawing Image Number		
	826-352C	GBOX FM3072 W/CLUTCH		
	826-288C	RPBY 826-352C		
	826-353C	GBOX FM3088/FM4088 W/CLUTCH		Rev. 2
	826-351C	REP BY 826-353C		Rev 1; Use up stock
1.	F6204080	OIL SEAL 40X80X10 DBL LIP		
1.	F6104080	RPBY F6204080		
2.	F6310080	SNAP RING I D80		
3.	F6016502	SHIM		
4.	F2030208	BEARING 30208		
5.	F1721009	RING BEVEL GEAR		
6.	F6320045	SNAP RING E D45		
7.	F1221003	SHAFT W/OVERRUN CLUTCH		
8.	F2006208	BEARING 6208		
9.	F6104580	OIL SEAL 45X80X8		
10.	F6320040	SNAP RING E D40		
11.	F6310090	SNAP RING I D90		
12.	F2236308	BEARING 6308 2RS		
13.	F1001060	EXTENSION FM3072		
13.	F1001062	EXTENSION FM 30/4088		Rev. 2
13.	F1001061	REP BY F1001062		Rev 1; Use up stock
14.	F6014005	SHIM		
15.	F1591042	SPACER		
16.	F1721007	PINION		
17.	F1781041	GASKET		
18.	F1641001	GEARBOX EC-60 HOUSING		
19.	F6016502	SHIM		
20.	F6100080	COVER		
21.	F1001016	SHAFT FM3072		
21.	F1001018	SHAFT FM 30/4088		Rev. 2
21.	F1001017	RPBY F1001018		Rev 1; Use up stock
22.	F3391230	BOLT M12X1,75X30 UNI 5739		
23.	F3970012	WASHER D12 UNI 1751		
24.	F3442018	PLUG PRESSURE RELIEF		
25.	F3441018	BEVEL PLUG 18X1,5		

*

*

NOTES:

1. When replacing or changing oil, use 30oz. of 80-90 weight oil.

Gearbox (826-352C) With Output Clutch

Applies to FM3072, FM3088, FM4088

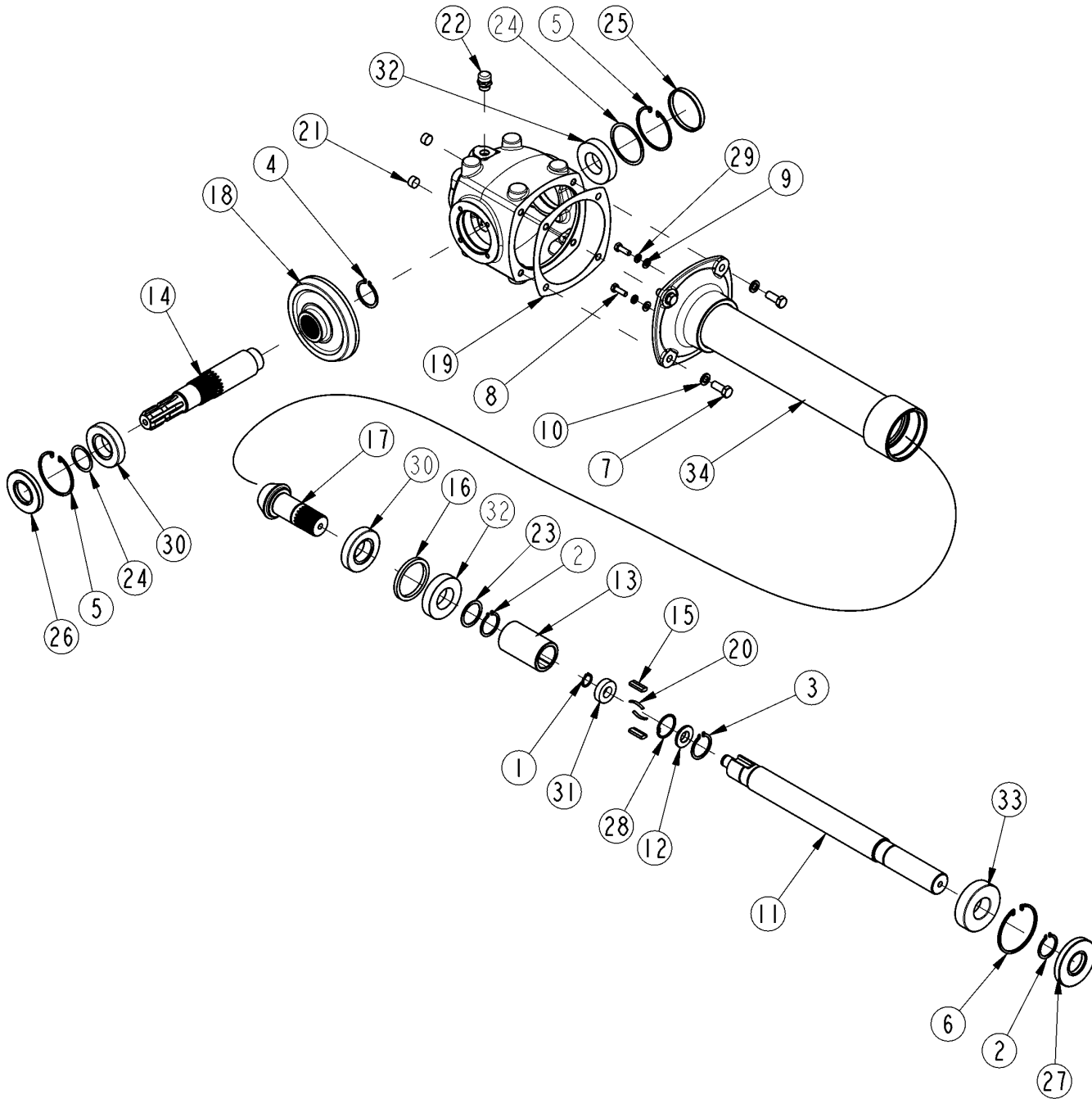

22294

Gearbox (826-352C) With Output Clutch**Applies to FM3072, FM3088, FM4088**

Ref	Part No.	Part Description	Comments	Revision
	dwg22294	Drawing Image Number		
	826-352C	GBOX FM3072 W/CLUTCH *		
1.	F6320020	SNAP RING E D20		
2.	F6320040	SNAP RING E D40		
3.	F6320042	CIRCLIP E 42mm DIA		
4.	F6320045	SNAP RING E D45		
5.	F6310080	SNAP RING I D80		
6.	F6310090	SNAP RING I D90		
7.	802-458C	HHCS M12X1.75X30 GR8.8		
8.	F3390825	BOLT M8X1.25X25 UNI 5739		
9.	F3930008	WASHER D8 UNI 1734		
10.	F3972012	WASHER D12 UNI 1751		
11.	F1201007	EC EXTENSION SHAFT L=615MM		
12.	F1201012	EC SPACER		
13.	F1221001	EC JOINT SLEEVE		
14.	F1221004	SHAFT		
15.	F1321001	PAWL		
16.	F1591042	SPACER		
17.	F1721007	PINION		
18.	F1721008	EC BEVEL GEAR Z27		
19.	F1781041	GASKET		
20.	F1811001	FLAT SPRING		
21.	F3441018	BEVEL PLUG 18X1,5		
22.	F3442018	PLUG PRESSURE RELIEF		
23.	F6014005	SHIM		
24.	F6016502	SHIM		
25.	F6100080	COVER		
26.	F6204080	OIL SEAL 40X80X10 DBL LIP		
26.	F6104080	RPBY F6204080		
27.	F6104090	EC SEAL 40X90X12		
28.	F6310042	EC BORE ELASTIC RING D42		
29.	F3972008	EC WASHER D8 UNI 1751		
30.	F2030208	BEARING 30208		
31.	F2106004	EC BEARING 6004		
32.	F2006208	BEARING 6208		
33.	F2106308	EC BEARING 6308		

Gearbox (826-353C) With Output Clutch

Applies to FM3072, FM3088, FM4088

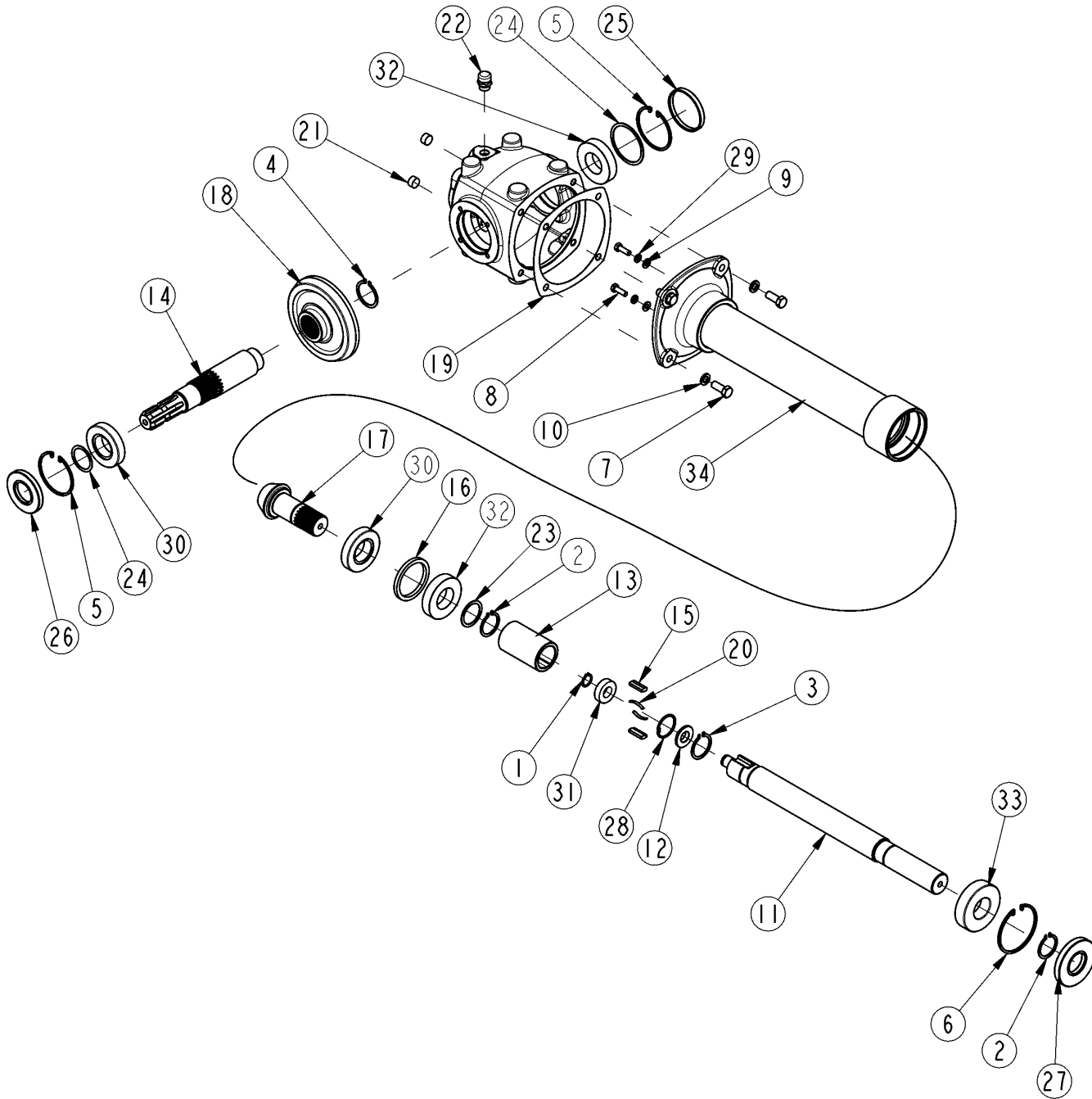

22294

Gearbox (826-353C) With Output Clutch**Applies to FM3072, FM3088, FM4088**

Ref	Part No.	Part Description	Comments	Revision
	dwg22294	Drawing Image Number		
	826-353C	GBOX FM3088/FM4088 W/CLUTCH *		
1.	F6320020	SNAP RING E D20		
2.	F6320040	SNAP RING E D40		
3.	F6320042	CIRCLIP E 42mm DIA		
4.	F6320045	SNAP RING E D45		
5.	F6310080	SNAP RING I D80		
6.	F6310090	SNAP RING I D90		
7.	802-458C	HHCS M12X1.75X30 GR8.8		
8.	F3390825	BOLT M8X1.25X25 UNI 5739		
9.	F3930008	WASHER D8 UNI 1734		
10.	F3972012	WASHER D12 UNI 1751		
11.	F1201009	EC EXTENSION SHAFT L=780MM		
12.	F1201012	EC SPACER		
13.	F1221001	EC JOINT SLEEVE		
14.	F1221004	SHAFT		
15.	F1321001	PAWL		
16.	F1591042	SPACER		
17.	F1721007	PINION		
18.	F1721008	EC BEVEL GEAR Z27		
19.	F1781041	GASKET		
20.	F1811001	FLAT SPRING		
21.	F3441018	BEVEL PLUG 18X1,5		
22.	F3442018	PLUG PRESSURE RELIEF		
23.	F6014005	SHIM		
24.	F6016502	SHIM		
25.	F6100080	COVER		
26.	F6204080	OIL SEAL 40X80X10 DBL LIP		
26.	F6104080	RPBY F6204080		
27.	F6104090	EC SEAL 40X90X12		
28.	F6310042	EC BORE ELASTIC RING D42		
29.	F3972008	EC WASHER D8 UNI 1751		
30.	F2030208	BEARING 30208		
31.	F2106004	EC BEARING 6004		
32.	F2006208	BEARING 6208		
33.	F2106308	EC BEARING 6308		
34.	F1001051	EC SHAFT L=780		

Label Placement

Applies to FM3072, FM3088, FM4088

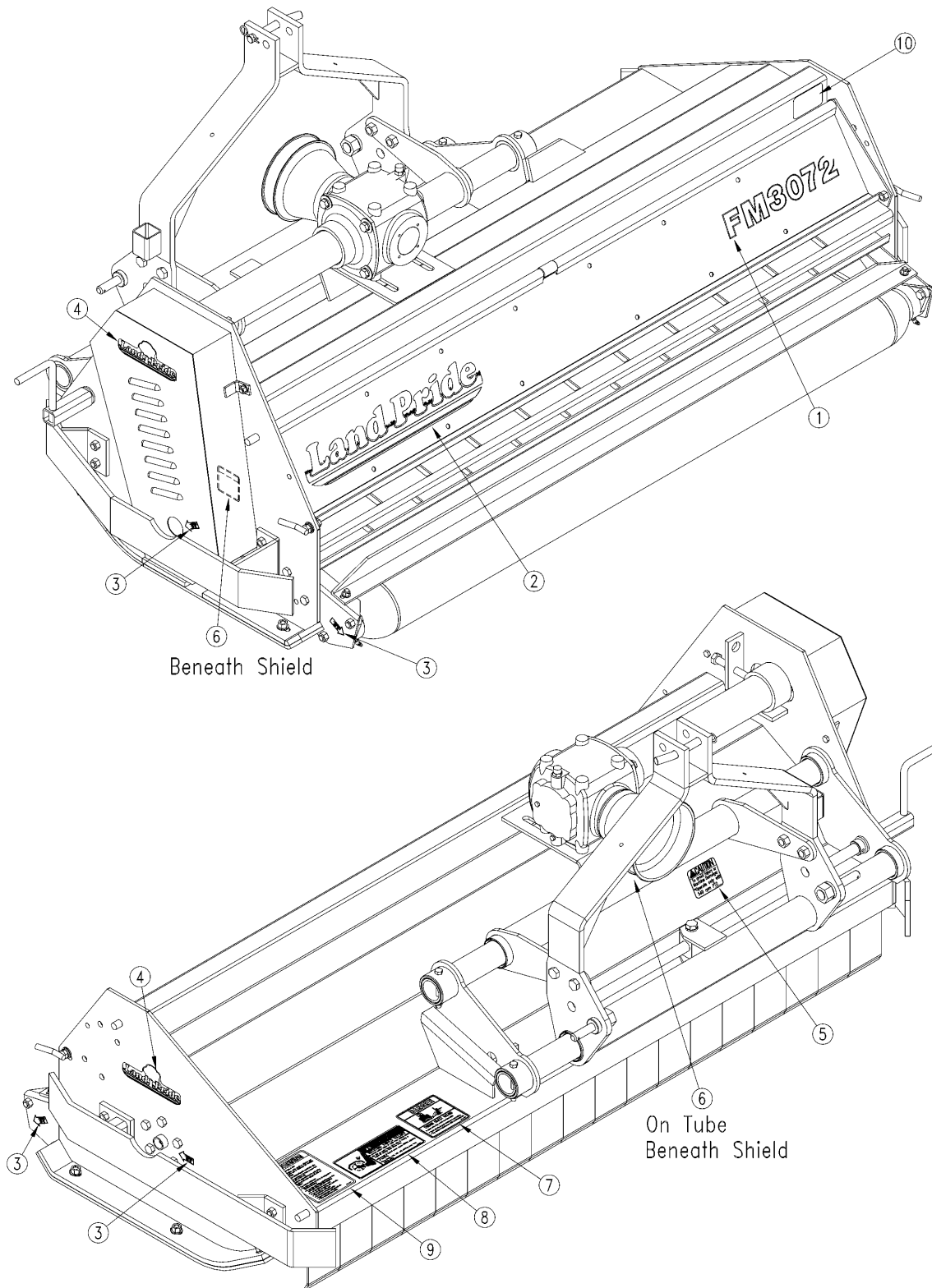

18065

Label Placement

Applies to FM3072, FM3088, FM4088

Ref	Part No.	Part Description	Comments	Revision
	dwg18065	Drawing Image Number		
	309-103A	FM3072 DECAL PACKAGE		
	309-104A	FM3088 DECAL PACKAGE		
	309-105A	FM4088 DECAL PACKAGE		
1.	838-072C	DECAL FM3072-BROWN		
1.	838-073C	DECAL FM3088-BROWN		
1.	838-074C	DECAL FM4088-BROWN		
2.	818-903C	DECAL LANDPRIDE 19" - BROWN		
3.	818-138C	DECAL GREASE EVERY 25 HOURS		
4.	818-896C	DECAL LP W/TREE 6" - 2 COLOR		
5.	818-130C	DECAL CAUTION 540 RPM		
6.	818-543C	DECAL DANGER PD GUARD MISS SML		
7.	818-556C	DECAL DANGER THROWN OBJ CUTTER		
8.	838-079C	DECAL DANGER ROTATING KNIVES		
9.	818-558C	DECAL WARNING GEN SAFE MOWER		
10.	818-230C	DECAL RED REFLECTOR		

Roller And Rotor

Applies to FM3072, FM3088, FM4088

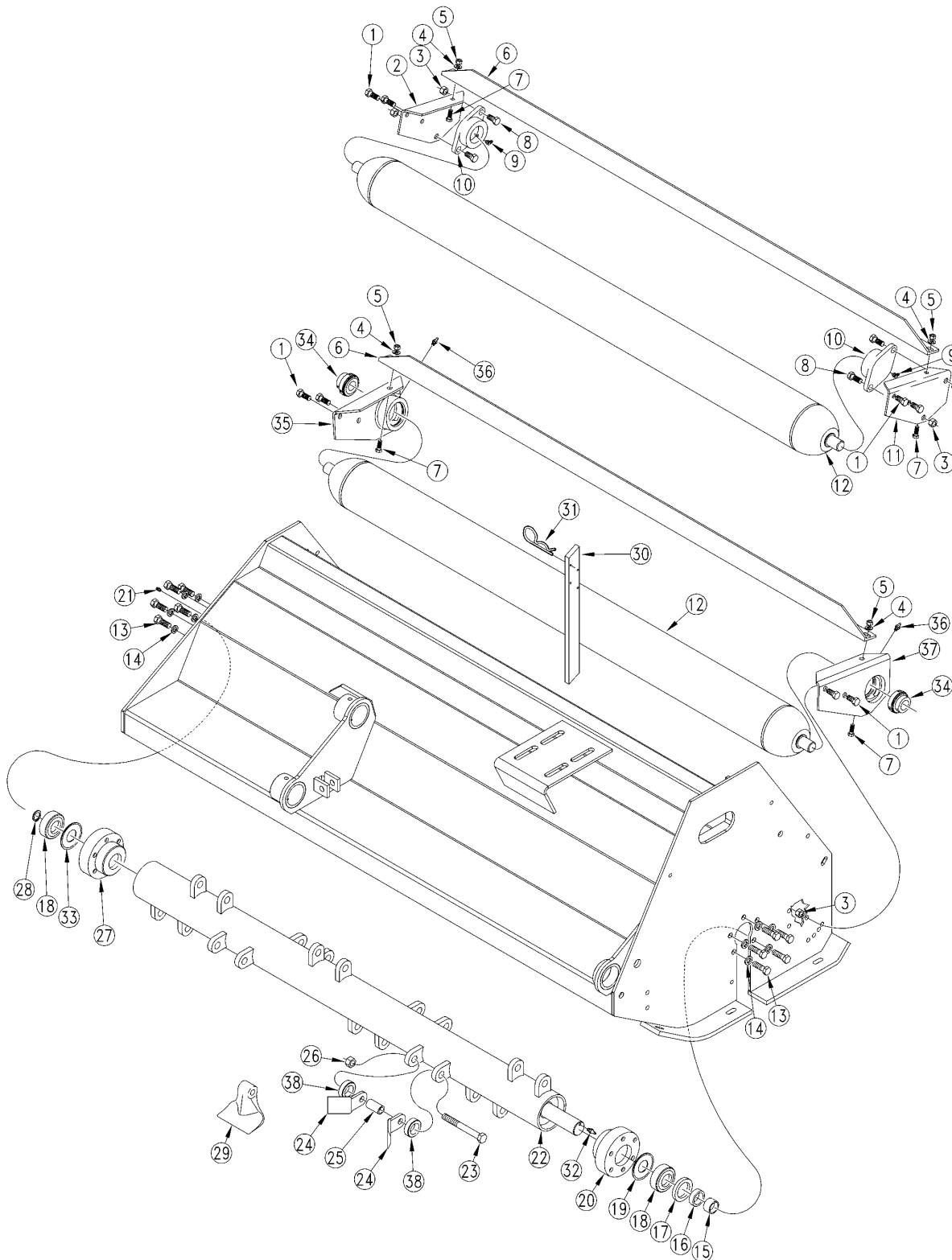

18062

Roller And Rotor

Applies to FM3072, FM3088, FM4088

Ref	Part No.	Part Description	Comments	Revision
	dwg18062	Drawing Image Number		
1.	802-458C	HHCS M12X1.75X30 GR8.8		
2.	F5136543	RPBY 309-061S	(S/N 307332-) Includes #34 & 35	
3.	F3667012	SELF LOCKING NUT M12	(S/N 307332-)	
4.	F3930010	WASHER D10 UNI 1734		
5.	F3540010	NUT M10 P.G. UNI 5587		
6.	F5866546	SCRAPER FM3072		
6.	F5866547	SCRAPER FM30-4088		
7.	F3391030	BOLT M10X1,5X30 UNI 5739		
8.	F3331235	BOLT TSPEI M12X35	(S/N 307332-)	
9.	F6560006	GREASE ZERK 45 DEGREE	(S/N 307332-)	
10.	F2020030	BEARING FLANGE 206 D30	(S/N 307332-)	
11.	F5136544	RPBY 309-062S	(S/N 307332-) Includes #34 & 37	
12.	F5006536	ROLLER FM3072		
12.	F5006537	ROLLER FM30-4088		
13.	F3391430	BOLT M12X1,75X25 UNI 5739		
14.	F3950014	WASHER D12 UNI 6798		
15.	F5536534	SPACER		
16.	F6205072	OIL SEAL D50X72X8 P.P		
17.	F5596108	METAL RING		
18.	F2822208	BEARING 22208	Rotor must be disassembled when replacing bearings. It is recommended to replace both bearings at once.	
19.	F2122208	SEAL 22208/JV		
20.	F5706098	SUPPORT		
21.	F6560010	GREASE ZERK M10X1,75		
22.	F5006651C	ROTOR WITH Y-BLADES FOR FM3072		
22.	F5006651M	ROTOR WITH HAMMERS FOR FM3072		
22.	F5006652C	FM3088 ROTOR W/Y-BLADES		
22.	F5006652M	ROTOR WITH HAMMERS FOR FM4088		
23.	F5716502	BOLT M16X2X95 UNI 5737		Rev. 2
23.	F3371690	BOLT M16X2X90 UNI 5737		Rev 1; Use up stock
24.	F5816618	Y BLADE	FM3072 QUANTITY 40 Y-BLADES FM3088 QUANTITY 48 Y-BLADES Used with knife only	
25.	F5536541	BUSHING		
26.	802-282C	RHSNB 5/16-18X1 GR5		
26.	F3667016	RPBY 803-282C		
27.	F5706099	SUPPORT		
28.	F6320040	SNAP RING E D40		
29.	F5716648	HAMMER	FM4088 QUANTITY 24 HAMMERS	
30.	F5836548	RAKE TEETH	FM4088 only Quantity 13	
31.	F6351005	COTTER HAIR PIN D5		
32.	F6560008	GREASE ZERK M8X1,25		
33.	F2022208	SEAL 22208/AV		
34.	F2030030	BEARING YAR 206 - 2 RF	(S/N 307333+)	
35.	F5006580	RIGHT ROLLER SUPPORT	(S/N 307333+)	
36.	F35602008	GREASE ZERK M 8X1	(S/N 307333+)	
37.	F5006581	LEFT ROLLER SUPPORT	(S/N 307333+)	
38.	827-001C	SPACER 1/2		Rev. 2
38.	F5596542	RPBY 827-001C		Rev 1; Use up stock

Drive

Applies to FM3188, FM4188

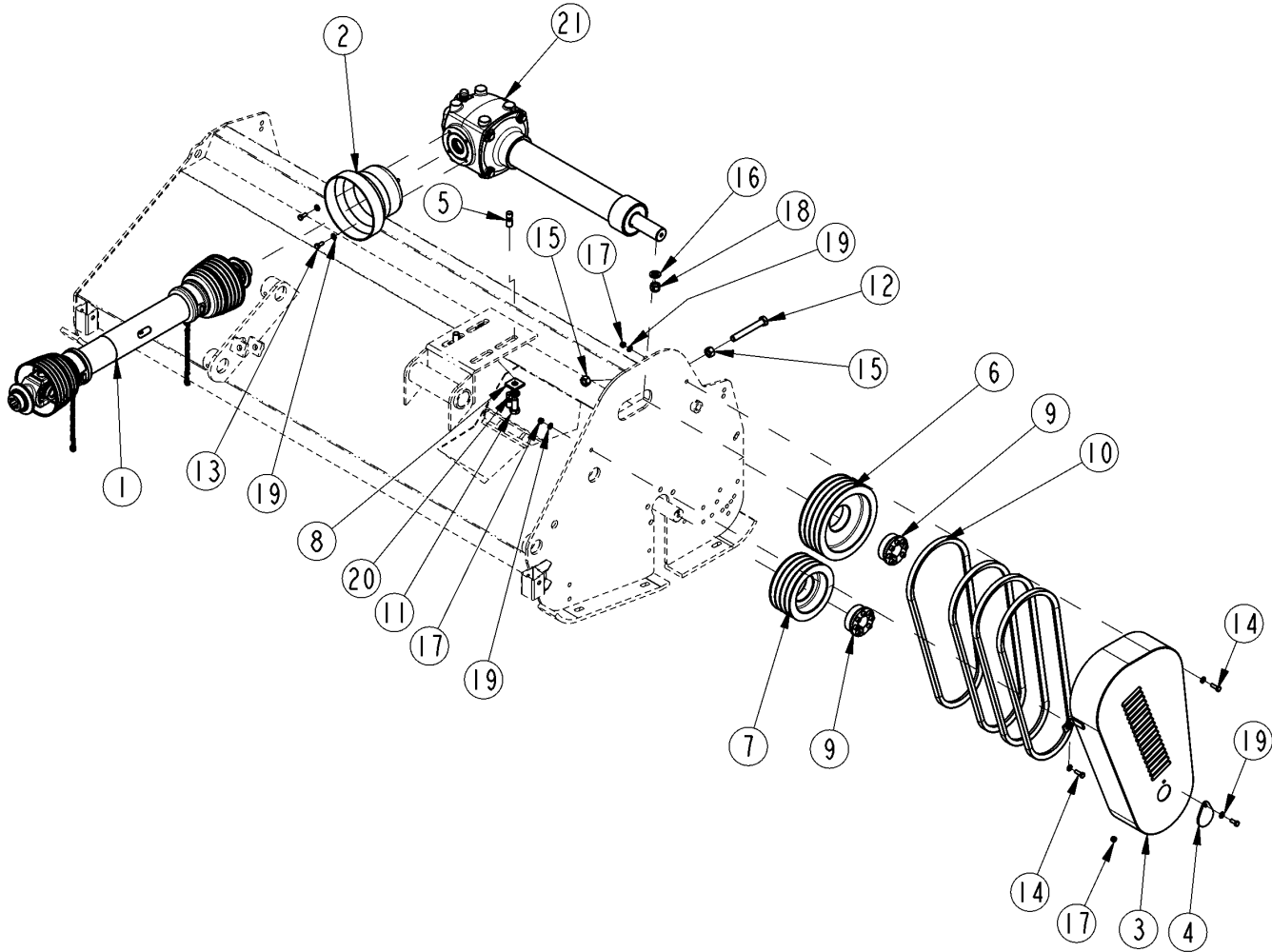

Drive**Applies to FM3188, FM4188**

Ref	Part No.	Part Description	Comments	Revision
	dwg24966	Drawing Image Number		
1.	826-278C	DRIVELINE FM30/40 AX6 NOCLUTCH		
2.	F1883510	DRIVELINE SHIELD		
3.	F5006602	BELT COVER		
4.	F5134389	COVER ZERK ACCESS		
5.	F5306298	STUD 16X45 UNI 5911		
6.	F5644070	PULLEY DRIVING 225X4		
7.	F5645102	PULLEY DRIVING 170X4		
8.	F5836617	SPACER		
9.	F6364080	SELF-LOCKING UNITS		
10.	F6721450	BELT V-TYPE SPB 1450	Qty 4 Ea.	
11.	F30216035	BOLT M16X35 UNI 5739		
12.	F30216120	BOLT M16X120 UNI 5739		
13.	F31508020	BOLT M8X20 UNI 5739		
14.	F31508025	BOLT M8X25 UNI 5739		
15.	F34000016	NUT M16 PG UNI 5587		
16.	F34020016	WASHER D16 UNI 6592		
17.	F34106008	NUT SELF LOCKING M8 PG		
18.	F34106016	NUT SELF LOCKING M16 PG		
19.	F34120008	WASHER D8 UNI 6592		
20.	F34121016	WASHER D16 UNI 1751		
21.	826-353C	GBOX FM3088/FM4088 W/CLUTCH		

Driveline (826-278C) Eurocardan

Applies to FM3188, FM4188

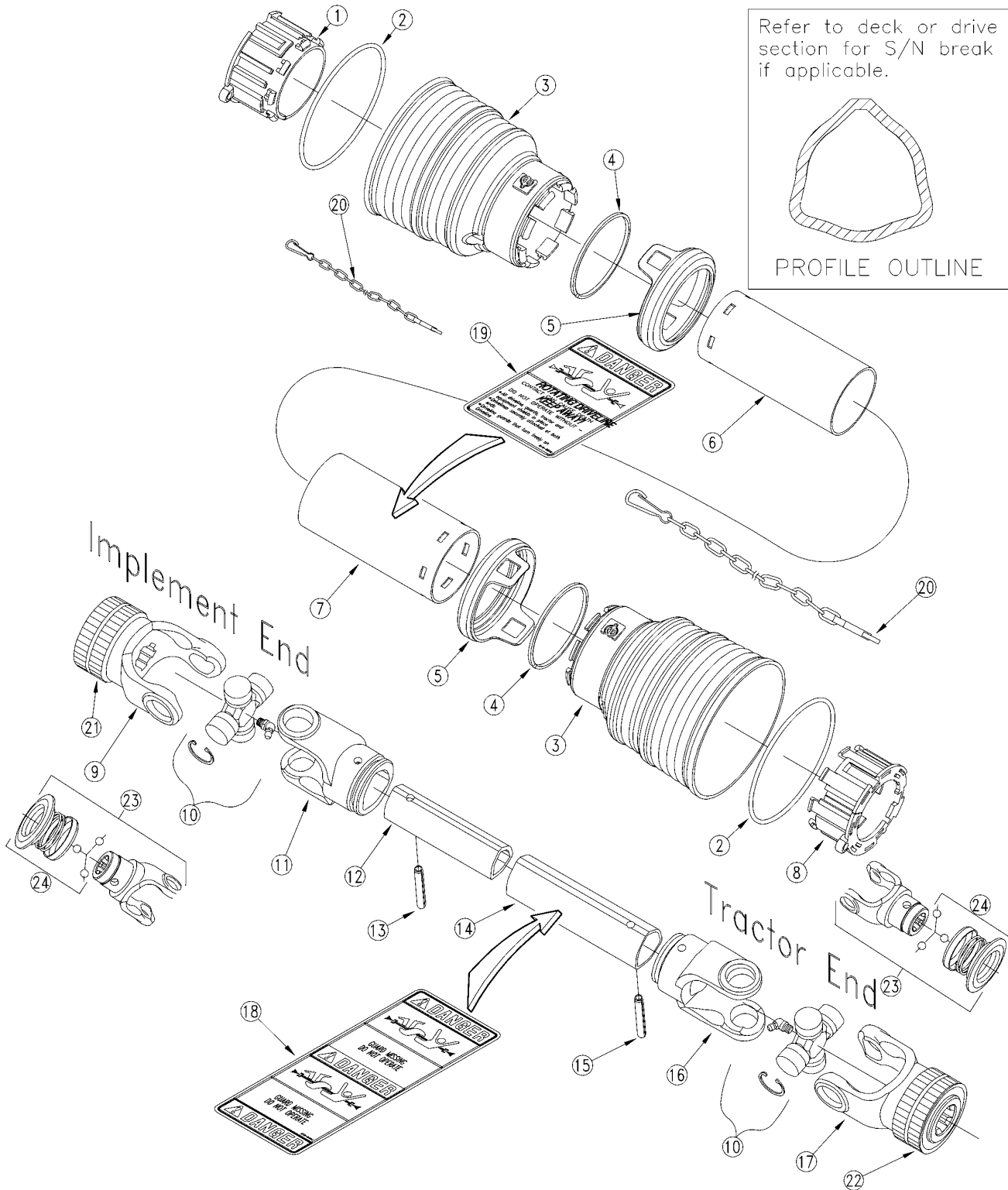

18064

Driveline (826-278C) Eurocardan**Applies to FM3188, FM4188**

Ref	Part No.	Part Description	Comments	Revision
	dwg18064	Drawing Image Number		
	826-278C	DRIVELINE FM30/40 AX6 NOCLUTCH		
1.	1786711	EC TUBE BEARING (INNER TUBE)		
2.	1215733	EC STIFFENING RING		
3.	1885703	EC STANDARD CONE		
4.	1215735	EC STOP RING		
5.	1885709	EC SAFETY SLEEVE		
6.	1877054	EC INNER TUBE (1877094) 540MM		
7.	1876054	EC OUTER TUBE (1876094) 540MM		
8.	1786710	EC TUBE BEARING (OUTER TUBE)		
9.	1116010	EC YOKE ASSY 1 3/8-6(IMP. END)		
10.	1006020	EC CROSS ASSEMBLY		
11.	1706029	EC INNER TUBE YOKE		
12.	1526064	EC INNER TUBE (1526084) 640MM		
13.	6331070	EC 10X70 ROLL PIN		
14.	1528064	EC OUTER TUBE (1528084) 640MM		
15.	6331080	EC 10X80-DIN-1481 O/TUBE R/PIN		
16.	1706027	EC OUTER TUBE YOKE		
17.	1016010	EC YOKE ASSEMBLY (TRACT. END)		
18.	818-540C	DECAL DANGER GUARD MISS PTO		
19.	818-552C	DECAL DANGER PTO DRIVELINE		
20.	044321	DRIVELINE SHIELD SAFETY CHAIN		
21.	1004224	EC TWIST COLLAR KIT (IMP. END)		
22.	1004220	EC TWIST COLLAR KIT (TRT. END)		
23.	1016013	EC YOKE ASSEMBLY		
24.	1004227	EC PULL COLLAR KIT EVOLUTION		

Frame & Hitch

Applies to FM3188, FM4188

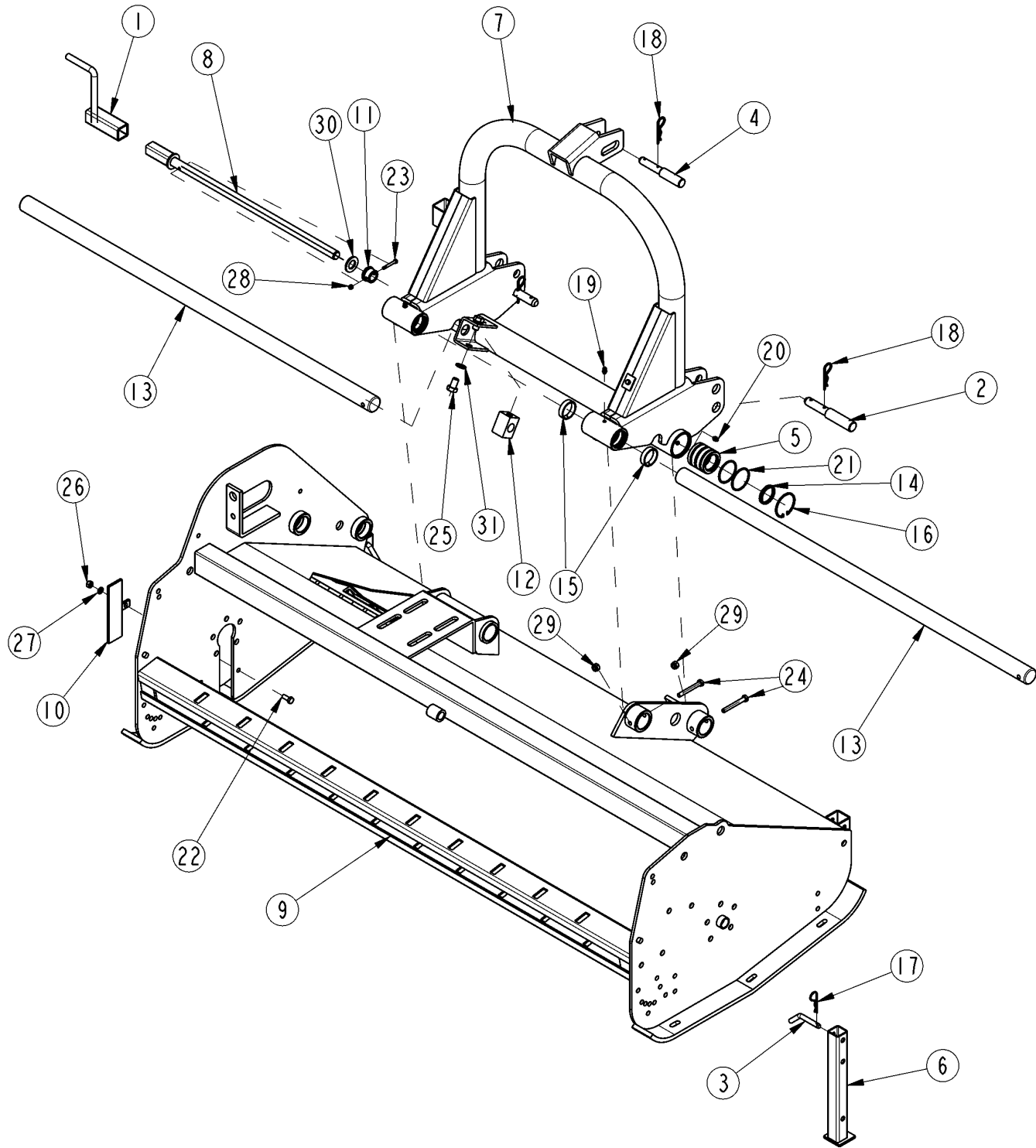

24967

Frame & Hitch

Applies to FM3188, FM4188

Ref	Part No.	Part Description	Comments	Revision
	dwg24967	Drawing Image Number		
1.	F4002235	ADJUSTMENT HANDLE		
2.	F4208292	PIN STEP, LOWER 3PT FM31/41		
3.	F4236115	PIN BENT		
4.	F4309180	PIN		
5.	F4782300	BUSHING		
6.	F5006114	PARK STAND		
7.	F5006606	MOBILE ARC		
8.	F5006610	SCREW ADJUSTMENT TRX185		
9.	F5006616	FRAME TRX220		
10.	F5006619	PROTECTION PLATE		
11.	F5206324	BUSHING		
12.	F5336326	COUPLING		
13.	F5426601	SHAFT		
14.	F6038342	OIL SCRAPER WRM 177208		
15.	F6038713	SEAL		
16.	F6310065	SNAP RING I D65		
17.	F6351003	COTTER HAIR PIN D3X60		
18.	F6351005	COTTER HAIR PIN D5		
19.	F6560008	GREASE ZERK M8X1,25		
20.	F6560010	ZERK M10X1,75		
21.	F6800836	O-RING 836		
22.	F30210025	BOLT M10X25 UNI 5739		
23.	F31306045	BOLT M6X45 UNI 5737		
24.	F31310080	BOLT M10X80 UNI 5737		
25.	F31516025	BOLT M16X25 UNI 5739		
26.	F34000010	NUT M10 PG UNI 5587		
27.	F34021010	WASHER D10 UNI1751		
28.	F34106006	NUT SELF LOCKING M6 PG		
29.	F34106010	NUT SELF LOCKING M10 PG		
30.	F34120024	WASHER D24 UNI 6592		
31.	F34121016	WASHER D16 UNI 1751		

Gearbox (826-353C) With Output Clutch

Applies to FM3188, FM4188

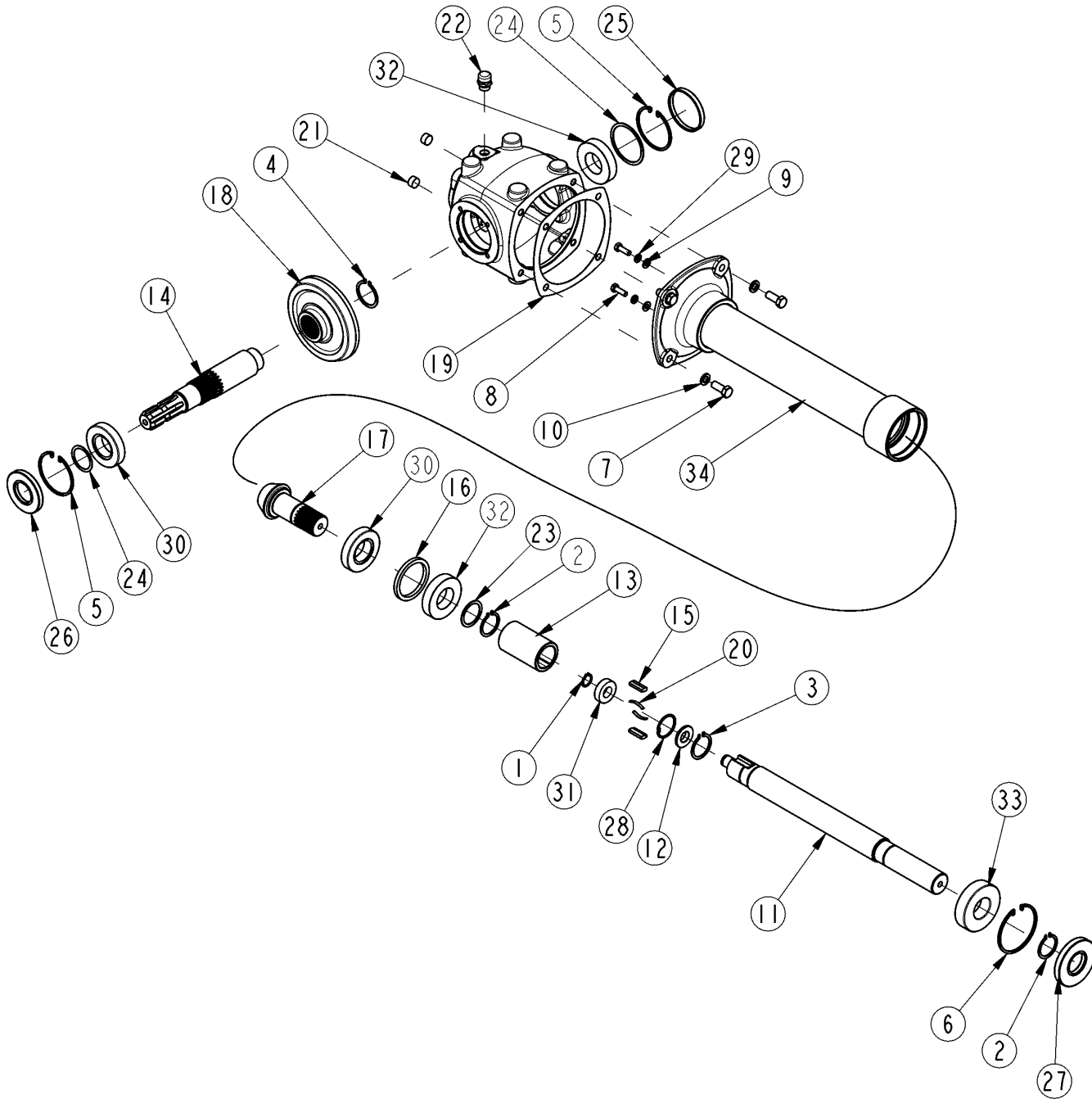

22294

Gearbox (826-353C) With Output Clutch**Applies to FM3188, FM4188**

Ref	Part No.	Part Description	Comments	Revision
	dwg22294	Drawing Image Number		
	826-353C	GBOX FM3088/FM4088 W/CLUTCH *		
1.	F6320020	SNAP RING E D20		
2.	F6320040	SNAP RING E D40		
3.	F6320042	CIRCLIP E 42mm DIA		
4.	F6320045	SNAP RING E D45		
5.	F6310080	SNAP RING I D80		
6.	F6310090	SNAP RING I D90		
7.	802-458C	HHCS M12X1.75X30 GR8.8		
8.	F3390825	BOLT M8X1.25X25 UNI 5739		
9.	F3930008	WASHER D8 UNI 1734		
10.	F3972012	WASHER D12 UNI 1751		
11.	F1201009	EC EXTENSION SHAFT L=780MM		
12.	F1201012	EC SPACER		
13.	F1221001	EC JOINT SLEEVE		
14.	F1221004	SHAFT		
15.	F1321001	PAWL		
16.	F1591042	SPACER		
17.	F1721007	PINION		
18.	F1721008	EC BEVEL GEAR Z27		
19.	F1781041	GASKET		
20.	F1811001	FLAT SPRING		
21.	F3441018	BEVEL PLUG 18X1,5		
22.	F3442018	PLUG PRESSURE RELIEF		
23.	F6014005	SHIM		
24.	F6016502	SHIM		
25.	F6100080	COVER		
26.	F6204080	OIL SEAL 40X80X10 DBL LIP		
26.	F6104080	RPBY F6204080		
27.	F6104090	EC SEAL 40X90X12		
28.	F6310042	EC BORE ELASTIC RING D42		
29.	F3972008	EC WASHER D8 UNI 1751		
30.	F2030208	BEARING 30208		
31.	F2106004	EC BEARING 6004		
32.	F2006208	BEARING 6208		
33.	F2106308	EC BEARING 6308		
34.	F1001051	EC SHAFT L=780		

Guards & Skid Shoe

Applies to FM3188, FM4188

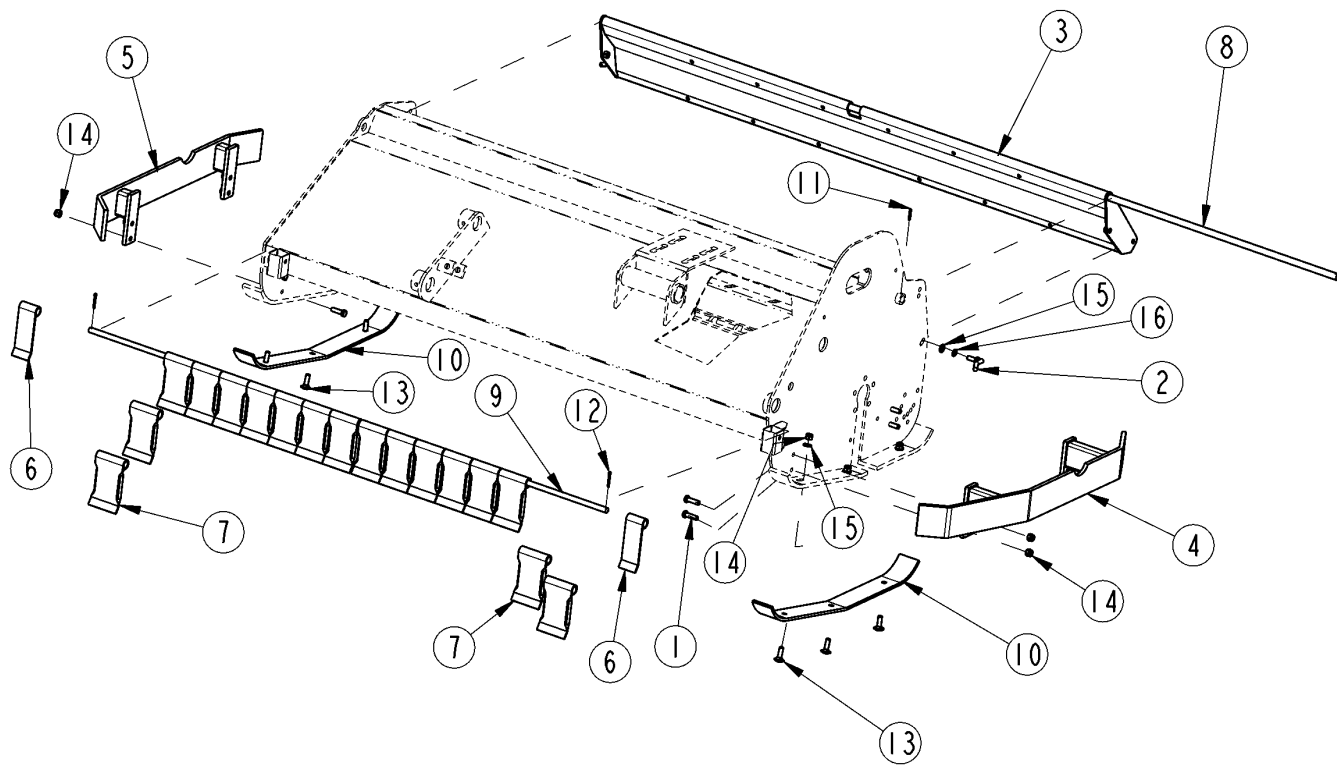

24968

Guards & Skid Shoe

Applies to FM3188, FM4188

Ref	Part No.	Part Description	Comments	Revision
	dwg24968	Drawing Image Number		
1.	F3391240	BOLT M12X40X1,75		
2.	F5006532	COVER ADJUSTING PIN		
3.	F5006636	BONNET TRX220		
4.	F5006675	BELT GUARD SHIELD LH		
5.	F5006676	SHIELD RH		
6.	F5136108	FRONT DEFLECTOR NARROW 2.36" WIDE		
7.	F5136109	DEFLECTOR 3.94" WIDE		
8.	F5236604	PIN GATE TRX220		
9.	F5236616	PIN		
10.	F5806601	SKID SHOE		
11.	F6330536	PIN ROLL 5MM X 36MM		
12.	F6340550	PIN COTTER D5X50		
13.	F33012040	RHSNB 0.47X1.57		
14.	F34106012	NUT SELF LOCKING M12 PG		
15.	F34120012	WASHER FLAT D12 UNI 6592		
16.	F34121012	WASHER LOCK D12 UNI 1751		

Label Placement

Applies to FM3188, FM4188

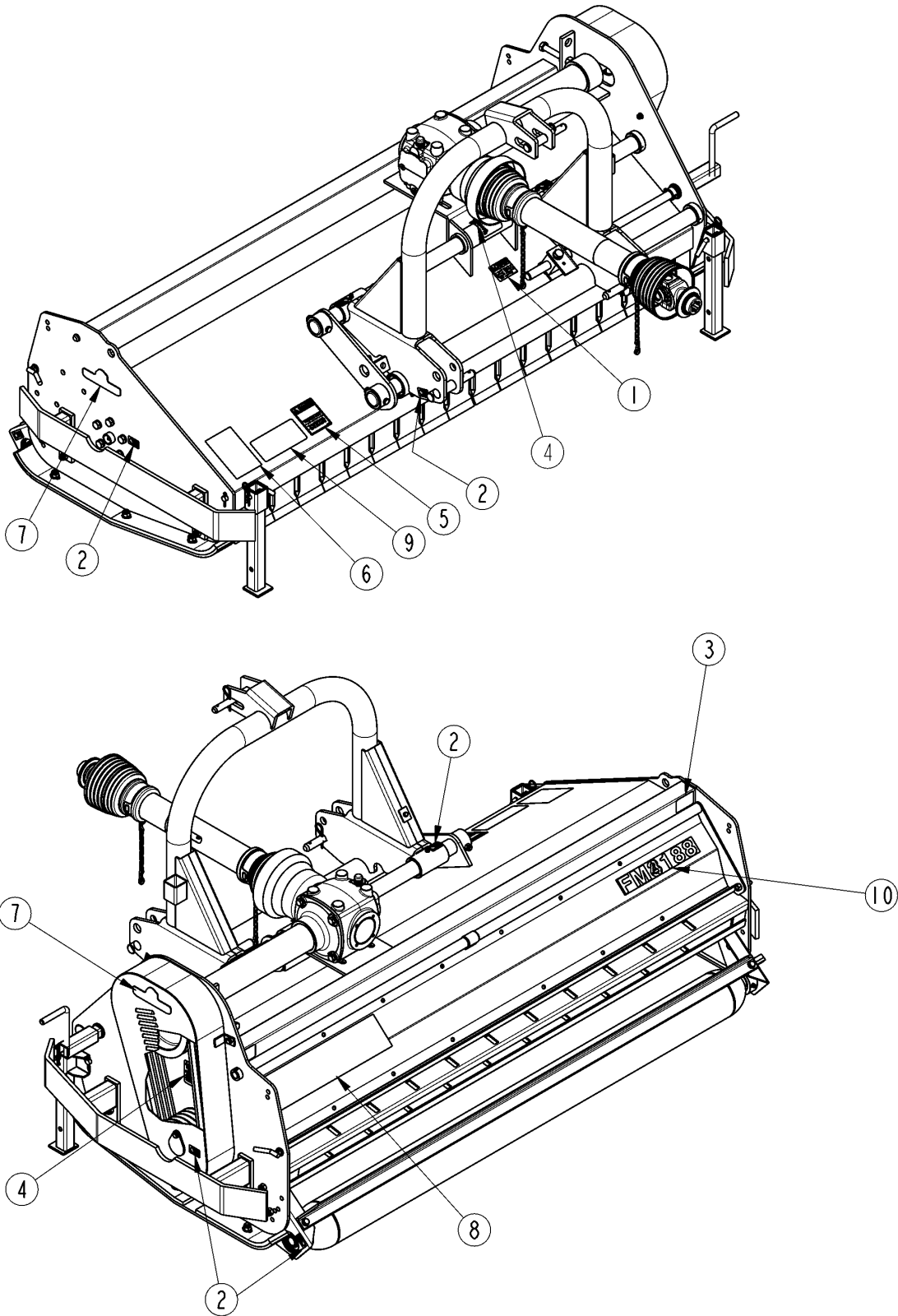

24969

Label Placement

Applies to FM3188, FM4188

Ref	Part No.	Part Description	Comments	Revision
	dwg24969	Drawing Image Number		
1.	818-130C	DECAL CAUTION 540 RPM		
2.	818-138C	DECAL GREASE EVERY 25 HOURS		
3.	818-230C	DECAL RED REFLECTOR		
4.	818-543C	DECAL DANGER PD GUARD MISS SML		
5.	818-556C	DECAL DANGER THROWN OBJ CUTTER		
6.	818-558C	DECAL WARNING GEN SAFE MOWER		
7.	818-896C	DECAL LP W/TREE 6" - 2 COLOR		
8.	818-903C	DECAL LANDPRIDE 19" - BROWN		
9.	838-079C	DECAL DANGER ROTATING KNIVES		
10.	848-046C	DECAL FM3188 BROWN		
10.	838-997C	DECAL FM4188-BROWN		

Roller & Rotor

Applies to FM3188, FM4188

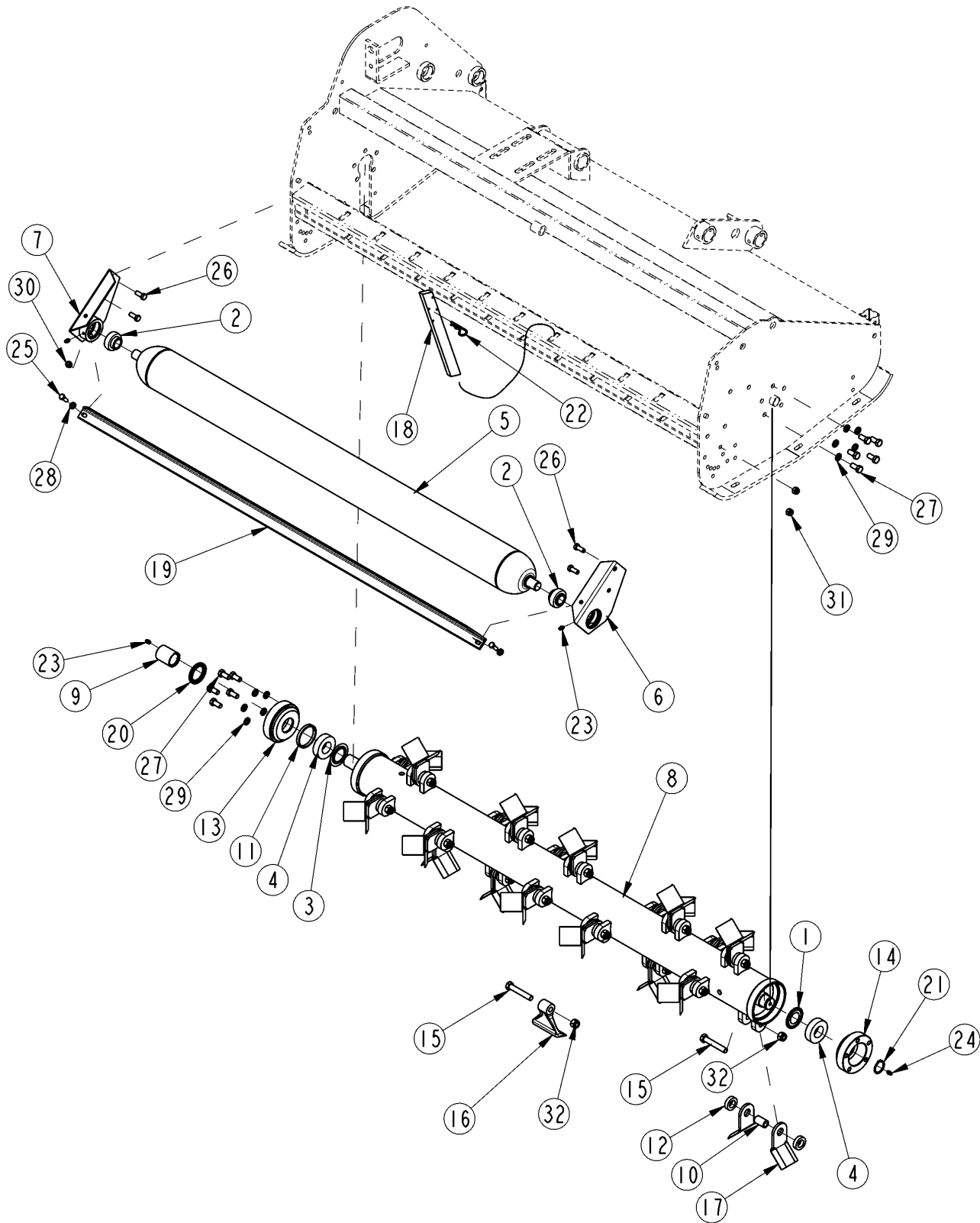

24970

Roller & Rotor

Applies to FM3188, FM4188

Ref	Part No.	Part Description	Comments	Revision
	dwg24970	Drawing Image Number		
1.	F2022208	SEAL 22208/AV		
2.	F2030030	BEARING YAR 206 - 2 RF		
3.	F2122208	SEAL 22208/JV		
4.	F2822208	BEARING 22208		
5.	F5006537	ROLLER		
6.	F5006580	RIGHT ROLLER SUPPORT		
7.	F5006581	LEFT ROLLER SUPPORT		
8.	F5006654	SHAFT TRX220		
9.	F5535117	SPACER		
10.	F5536541	BUSHING		
11.	F5596108	METAL RING		
12.	827-001C	SPACER 1/2		
13.	F5706098	SUPPORT		
14.	F5706099	SUPPORT		
15.	F5716502	BOLT M16X2X95 UNI 5737		
16.	F5716648	HAMMER	FM4188 24 Required	
17.	F5816618	Y BLADE	FM3188 48 Required	
18.	F5836548	RAKE TEETH	10 Ea. Required	
19.	F5866547	SCRAPER FM30-4088		
20.	F6205072	OIL SEAL D50X72X8 P.P.		
21.	F6320040	SNAP RING E D40		
22.	F6351005	COTTER HAIR PIN D5		
23.	F6560008	GREASE ZERK M8X1,25		
24.	F6560010	ZERK M10X1,75		
25.	F30210030	BOLT M10X30 UNI 5739		
26.	F30212030	BOLT M12X30 UNI 5739		
27.	F30214030	BOLT M14X30 UNI 5739		
28.	F34020010	WASHER D10 UNI 6592		
29.	F34022014	WASHER D14 UNI 6798		
30.	F34106010	NUT SELF LOCKING M10 PG		
31.	F34106012	NUT SELF LOCKING M12 PG		
32.	F34106016	NUT SELF LOCKING M16 PG		



Part Number Index

The Part Number Index is a numeric index of all part numbers included in this manual. The index shows what page(s) the part is used on.

Part Number	Page	Part Number	Page	Part Number	Page	Part Number	Page
044321	9, 11, 25, 43	826-278C	23, 25, 41, 43	F1721105	17	F34120008	41
1004020	9, 11	826-287C	7, 15	F1721109	17	F34120012	49
1004220	9, 11, 25, 43	826-288C	23, 29, 31	F1781041	29, 31, 33, 35, 47	F34120024	45
1004224	11, 25, 43	826-338C	7, 17	F1781107	15, 17	F34121012	49
1004225	9, 11	826-339C	7, 11	F1811001	17, 29, 33, 35, 47	F34121016	41, 45
1004227	25, 43	826-351C	23, 29, 31	F1883510	7, 23, 41	F3441018	15, 17, 29, 31, 33, 35, 47
1006020	25, 43	826-352C	23, 31, 33	F2006208	29, 31, 33, 35, 47	F3442018	15, 17, 29, 31, 33, 35, 47
1006065	11	826-353C	23, 31, 35, 41, 47	F2020030	39	F3540010	39
1014010	9, 11	827-001C	39, 53	F2020035	7	F3540024	13, 27
1014012	9, 11	838-070C	19	F2022207	21	F3560008	13
1016010	25, 43	838-071C	19	F2022208	39, 53	F3560012	13, 21
1016013	25, 43	838-072C	37	F2030030	21, 39, 53	F3560014	7
1114010	11	838-073C	37	F2030208	29, 31, 33, 35, 47	F3560016	23
1116010	25, 43	838-074C	37	F2030307	29	F35602008	39
1140001	11	838-079C	19, 37, 51	F2106004	33, 35, 47	F3667006	27
1140003	11	838-082C	19	F2106009	15, 17	F3667008	27
1213233	9, 11	838-682C	19	F2106207	15, 17	F3667010	7, 13, 27
1215733	25, 43	838-997C	51	F2106209	15, 17	F3667012	7, 13, 15, 21, 27, 39
1215735	25, 43	848-046C	51	F2106308	33, 35, 47	F3667014	13
1504226	9	dwg18035	15	F2122207	21	F3667016	21, 27, 39
1524046	9, 11	dwg18036	13	F2122208	39, 53	F3930008	13, 27, 29, 33, 35, 47
1525046	9, 11	dwg18037	9	F2226204	7	F3930010	39
1526064	25, 43	dwg18038	21	F2236308	29, 31	F3930012	13, 21, 27
1528064	25, 43	dwg18039	7	F2822207	21	F3932008	7, 23
1581038	9	dwg18040	19	F2822208	39, 53	F3932012	27
1704027	9, 11	dwg18060	27	F30210025	45	F3932016	23
1704029	9, 11	dwg18061	23	F30210030	53	F3950012	21
1706027	25, 43	dwg18062	39	F30212030	53	F3950014	39
1706029	25, 43	dwg18063	31	F30214030	53	F3970012	31
1784210	9, 11	dwg18064	25, 43	F30216035	41	F3971008	29
1784211	9, 11	dwg18065	37	F30216120	41	F3971012	29
1784212	9, 11	dwg19600	11	F31306045	45	F3972008	33, 35, 47
1786710	25, 43	dwg22294	33, 35, 47	F31310080	45	F3972012	7, 13, 15, 17, 21, 27, 33, 35, 47
1786711	25, 43	dwg22312	17	F31508020	41	F3972016	23, 27
1872038	9, 11	dwg22431	29	F31508025	41	F3972024	13, 27
1873038	9, 11	dwg24966	41	F31516025	45	F4002235	27, 45
1876054	25, 43	dwg24967	45	F3201235	13, 27	F4208227	13, 27
1877054	25, 43	dwg24968	49	F3270610	21	F4208292	45
1884201	9, 11	dwg24969	51	F33012040	49	F4211263	7
1884202	9, 11	dwg24970	53	F3311260	7, 15, 17	F4236115	45
1884203	9, 11	F1001016	29, 31	F3331235	39	F4301589	13
1885703	25, 43	F1001017	31	F3370660	27	F4301591	27
1885709	25, 43	F1001018	29, 31	F3371090	27	F4309180	45
309-060A	15	F1001051	35, 47	F3371650	27	F4782300	45
309-101A	19	F1001060	29, 31	F3371690	21, 39	F5005005	13
309-102A	19	F1001061	31	F3390816	7, 23	F5005006	13
309-103A	37	F1001062	29, 31	F3390825	13, 27, 29, 33, 35, 47	F5005009	13
309-104A	37	F1201007	33	F3391025	13	F5005010	21
309-105A	37	F1201009	35, 47	F3391030	39	F5005011	21
6330855	9, 11	F1201012	33, 35, 47	F3391220	15	F5005017	21
6330860	9, 11	F1221001	33, 35, 47	F3391225	7, 13, 17, 21	F5005018	21
6331070	25, 43	F1221003	29, 31	F3391230	29, 31	F5005024	13
6331080	25, 43	F1221004	33, 35, 47	F3391240	13, 27, 49	F5005025	13
802-282C	39	F1221103	15, 17	F3391430	39	F5005046	13
802-458C	21, 29, 33, 35, 39, 47	F1221104	15	F3391440	7, 13	F5005062	13
802-613C	21	F1221107	17	F3391612	23	F5005067	13
803-281C	17	F1221109	17	F3391625	27	F5005069	7
818-130C	19, 37, 51	F1301129	7	F3391635	23	F5005133	13
818-138C	19, 37, 51	F1301130	7	F34000010	45	F5005169C	21
818-230C	19, 37, 51	F1321001	17, 29, 33, 35, 47	F34000016	41	F5005170C	21
818-540C	9, 11, 19, 25, 43	F1531106	15, 17	F34020010	53	F5005610	21
818-543C	19, 37, 51	F1591042	29, 31, 33, 35, 47	F34020016	41	F5005611	27
818-552C	9, 11, 19, 25, 43	F1641001	29, 31	F34021010	45	F5006114	45
818-556C	19, 37, 51	F1641101	15, 17	F34022014	53	F5006304	27
818-558C	19, 37, 51	F1701105	15, 17	F34106006	45	F5006323	27
818-558C	19, 37, 51	F1721007	29, 31, 33, 35, 47	F34106008	41		
818-896C	19, 37, 51	F1721008	33, 35, 47	F34106010	45, 53		
818-903C	19, 37, 51	F1721009	29, 31	F34106012	49, 53		
822-166C	15	F1721103	15	F34106016	41, 53		
826-277C	7, 9	F1721104	15				



Part Number Index (continued)

<u>Part Number</u>	<u>Page</u>	<u>Part Number</u>	<u>Page</u>
F5006513	27	F5815160	21
F5006514	27	F5816618	39, 53
F5006518	27	F5836548	39, 53
F5006519	27	F5836617	41
F5006522	27	F5865004	21
F5006523	27	F5865005	21
F5006532	27, 49	F5866546	39
F5006536	39	F5866547	39, 53
F5006537	39, 53	F6014005	29, 31, 33, 35, 47
F5006565	27	F6016502	29, 31, 33, 35, 47
F5006580	39, 53	F6038342	45
F5006581	39, 53	F6038713	45
F5006602	41	F6100072	15, 17
F5006606	45	F6100080	29, 31, 33, 35, 47
F5006610	45	F6103580	29
F5006616	45	F6104080	29, 31, 33, 35, 47
F5006619	45	F6104090	33, 35, 47
F5006636	49	F6104580	31
F5006651C	39	F6203572	15, 17
F5006651M	39	F6204080	29, 31, 33, 35, 47
F5006652C	39	F6204562	15, 17, 21
F5006652M	39	F6205072	39, 53
F5006654	53	F6310042	33, 35, 47
F5006675	49	F6310065	45
F5006676	49	F6310072	15, 17
F5134389	41	F6310080	29, 31, 33, 35, 47
F5136108	49	F6310085	15, 17
F5136109	49	F6310090	29, 31, 33, 35, 47
F5136543	39	F6320020	7, 33, 35, 47
F5136544	39	F6320035	21
F5136608	13, 27	F6320040	29, 31, 33, 35, 39, 47, 53
F5136609	13, 27	F6320042	15, 17, 29, 33, 35, 47
F5206324	27, 45	F6320045	15, 17, 31, 33, 35, 47
F5235158	13	F6330536	49
F5235159	13	F6330540	13, 27
F5236604	49	F6340550	49
F5236615	27	F6350010	13, 27
F5236616	27, 49	F6351003	45
F5305017	7	F6351004	13, 27
F5306298	41	F6351005	39, 45, 53
F5336326	27, 45	F6361030	15
F5426601	45	F6363565	7
F5532111	13, 27	F6364080	23, 41
F5532112	27	F6560006	7, 39
F5535117	53	F6560008	21, 39, 45, 53
F5535159	21	F6560010	39, 45, 53
F5536534	39	F6721046	7
F5536541	39, 53	F6721450	41
F5536626	21	F6730056	23
F5595160	21	F6800836	45
F5595609	27		
F5596108	39, 53		
F5596542	39		
F5644070	41		
F5645102	41		
F5645152	7		
F5645153	7		
F5646332	23		
F5646333	23		
F5705152	21		
F5705153	21		
F5706098	39, 53		
F5706099	39, 53		
F5716502	39, 53		
F5716648	39, 53		
F5785069	7		
F5785170	7		
F5785171	7		
F5805001	13		
F5806500	27		
F5806601	49		



Great Plains Manufacturing, Inc.

Corporate Office: P.O. Box 5060
Salina, Kansas 67402-5060 USA

www.landpride.com

Free Manuals Download Website

<http://myh66.com>

<http://usermanuals.us>

<http://www.somanuals.com>

<http://www.4manuals.cc>

<http://www.manual-lib.com>

<http://www.404manual.com>

<http://www.luxmanual.com>

<http://aubethermostatmanual.com>

Golf course search by state

<http://golfingnear.com>

Email search by domain

<http://emailbydomain.com>

Auto manuals search

<http://auto.somanuals.com>

TV manuals search

<http://tv.somanuals.com>