

Powered Rakes

PR1660, PR1672 & PR1690

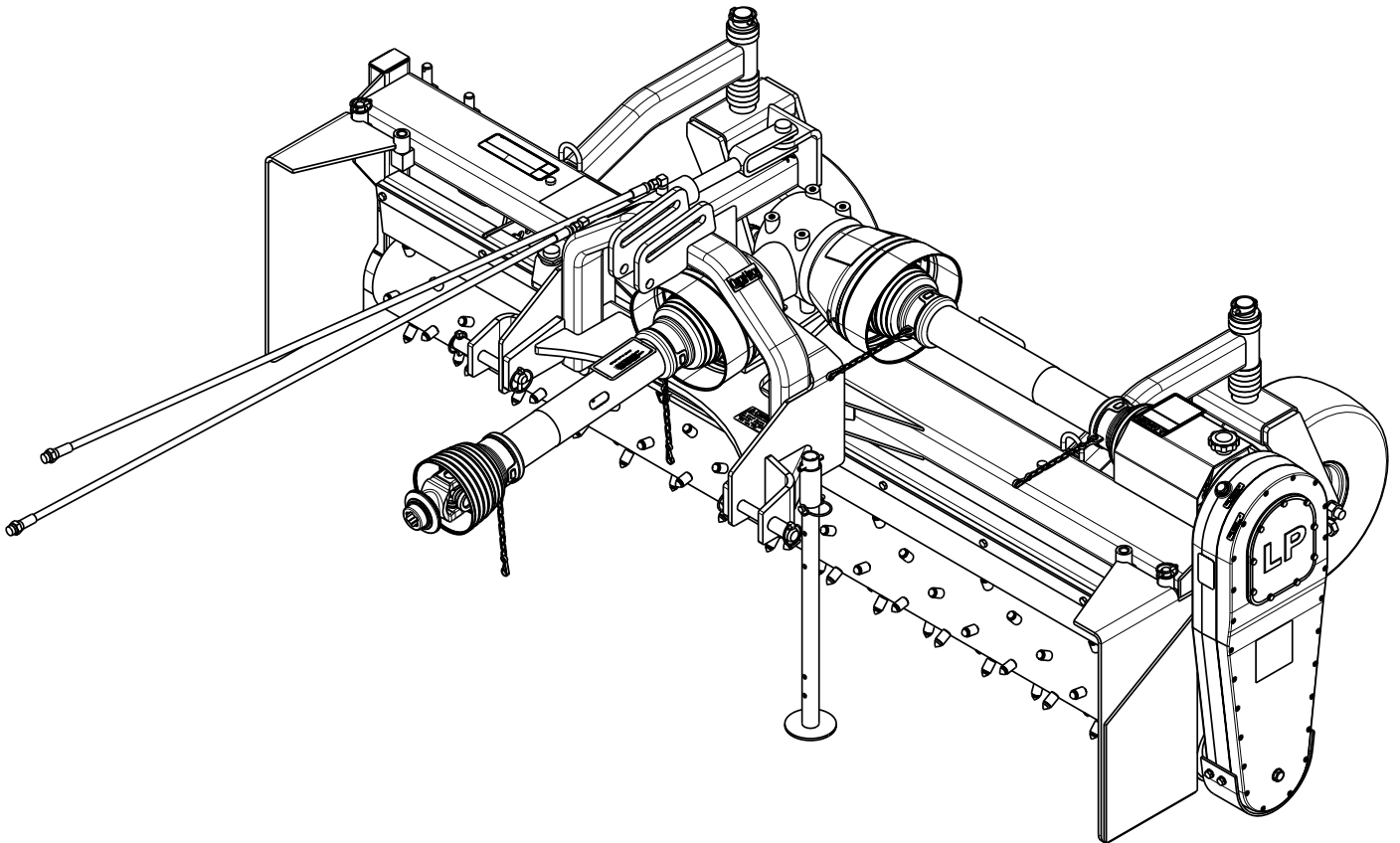

24503

314-216M Operator's Manual



Read the Operator's manual entirely. When you see this symbol, the subsequent instructions and warnings are serious - follow without exception. Your life and the lives of others depend on it!

© Copyright 2006 Printed 10/20/06

Cover photo may show optional equipment not supplied with standard unit.



Important Safety Information	1	Section 4: Maintenance & Lubrication . . .	16
Safety at All Times	1	Maintenance	16
Look For The Safety Alert Symbol	1	Slip Clutch Maintenance	16
Safety Labels	4	Slip Clutch with Hex Socket Bolts	16
Introduction	8	Clutch Run-in (with hex socket bolts)	16
Application	8	Clutch Assembly (with hex socket bolts)	16
Using This Manual	8	Slip Clutch with Hex Head Bolts	17
Terminology	8	Clutch Run-In (with hex head bolts)	17
Definitions	8	Clutch Assembly (with hex head bolts)	18
Owner Assistance	8	Drive Chain Maintenance	18
Serial Number Plate	8	Chain Case Skid Shoe Replacement	18
Further Assistance	8	Sprocket and Chain Replacement	19
Section 1: Assembly and Set-Up	9	Storage	20
Tractor Requirements	9	Lubrication	21
Hydraulic Option	9	Pivot	21
Tractor Hook-Up	9	Gauge Wheel Spindle	21
PTO Hook-Up	10	Gauge Wheel Axle	21
Hydraulic Hook-up (Optional)	11	Drive Chain	22
Section 2: Operating	12	Non-Drive Bearing	22
Operating Check List	12	Gearbox	22
Transporting	12	Section 5: Specifications & Capacities . . .	23
Operating Instructions	12	Section 6: Features & Benefits	24
Section 3: Adjustments	14	Section 7: Troubleshooting	25
Gauge Wheels	14	Section 8: Appendix	26
Rake Angle	14	Torque Values Chart for Common Bolt Sizes	26
Material Control Deflector	14	Tire Inflation Chart	26
Drive Chain Adjustment	15	Warranty	27
End Plates	15		

© Copyright 2006 All rights Reserved

Land Pride provides this publication "as is" without warranty of any kind, either expressed or implied. While every precaution has been taken in the preparation of this manual, Land Pride assumes no responsibility for errors or omissions. Neither is any liability assumed for damages resulting from the use of the information contained herein. Land Pride reserves the right to revise and improve its products as it sees fit. This publication describes the state of this product at the time of its publication, and may not reflect the product in the future.

Land Pride is a registered trademark.

All other brands and product names are trademarks or registered trademarks of their respective holders.

Printed in the United States of America.

Important Safety Information

These are common practices that may or may not be applicable to the products described in this manual.

Safety at All Times

Thoroughly read and understand the instructions given in this manual before operation. Refer to the "Safety Label" section, read all instructions noted on them.

Do not allow anyone to operate this equipment who has not fully read and comprehended this manual and who has not been properly trained in the safe operation of the equipment.

- ▲ Operator should be familiar with all functions of the unit.
- ▲ Operate implement from the driver's seat only.
- ▲ Make sure all guards and shields are in place and secured before operating the implement.
- ▲ Do not leave tractor or implement unattended with engine running.
- ▲ Dismounting from a moving tractor could cause serious injury or death.
- ▲ Do not stand between the tractor and implement during hitching.
- ▲ Keep hands, feet, and clothing away from power-driven parts.
- ▲ Wear snug fitting clothing to avoid entanglement with moving parts.
- ▲ Watch out for wires, trees, etc., when raising implement. Make sure all persons are clear of working area.
- ▲ Turning tractor too tight may cause implement to ride up on wheels. This could result in injury or equipment damage.

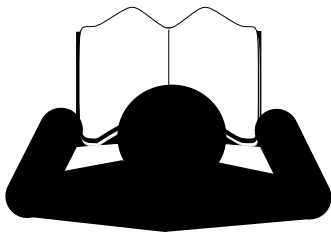

Look For The Safety Alert Symbol

The SAFETY ALERT SYMBOL indicates there is a potential hazard to personal safety involved and extra safety precaution must be taken. When you see this symbol, be alert and carefully read the message that follows it. In addition to design and configuration of equipment, hazard control and accident prevention are dependent upon the awareness, concern, prudence and proper training of personnel involved in the operation, transport, maintenance and storage of equipment.

Be Aware of Signal Words

A Signal word designates a degree or level of hazard seriousness. The signal words are:

DANGER

Indicates an imminently hazardous situation which, if not avoided, will result in death or serious injury. This signal word is limited to the most extreme situations, typically for machine components that, for functional purposes, cannot be guarded.

WARNING

Indicates a potentially hazardous situation which, if not avoided, could result in death or serious injury, and includes hazards that are exposed when guards are removed. It may also be used to alert against unsafe practices.

CAUTION

Indicates a potentially hazardous situation which, if not avoided, may result in minor or moderate injury. It may also be used to alert against unsafe practices.

For Your Protection

- ▲ Thoroughly read and understand the "Safety Label" section, read all instructions noted on them.

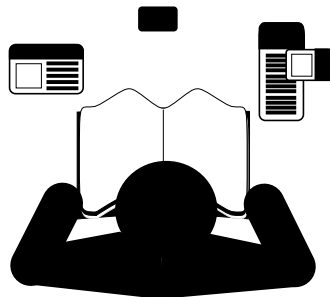

Shutdown and Storage

- ▲ Lower machine to ground, put tractor in park, turn off engine, and remove the key.
- ▲ Detach and store implements in a area where children normally do not play. Secure implement by using blocks and supports.

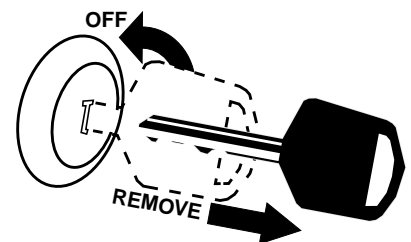

Important Safety Information

These are common practices that may or may not be applicable to the products described in this manual.

Use Safety Lights and Devices

- ▲ Slow moving tractors, self-propelled equipment and towed implements can create a hazard when driven on public roads. They are difficult to see, especially at night.
- ▲ Flashing warning lights and turn signals are recommended whenever driving on public roads. Use lights and devices provided with implement.

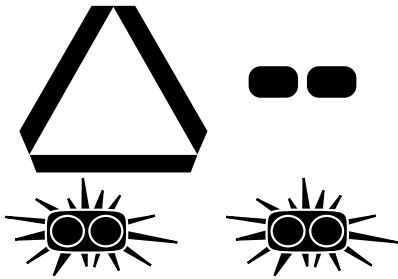

Transport Machinery Safely

- ▲ Comply with state and local laws.
- ▲ Maximum transport speed for implement is 20 mph. **DO NOT EXCEED.** Never travel at a speed which does not allow adequate control of steering and stopping. Some rough terrain require a slower speed.
- ▲ Sudden braking can cause a towed load to swerve and upset. Reduce speed if towed load is not equipped with brakes.

- ▲ Use the following maximum speed - tow load weight ratios as a guideline:
20 mph when weight is less than or equal to the weight of tractor.
10 mph when weight is double the weight of tractor.
IMPORTANT: Do not tow a load that is more than double the weight of tractor.

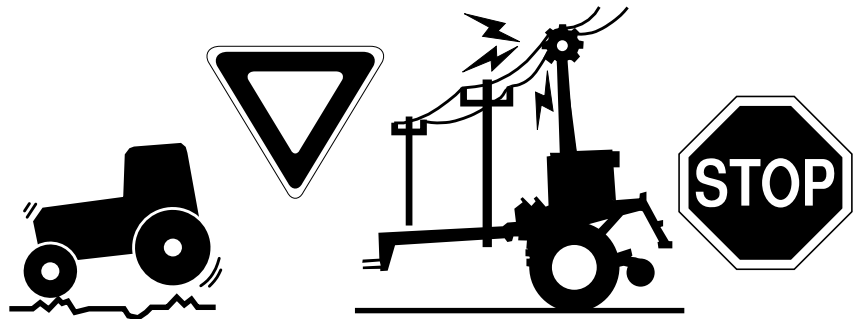

Keep Riders Off Machinery

- ▲ Riders obstruct the operator's view, they could be struck by foreign objects or thrown from the machine.
- ▲ Never allow children to operate equipment.

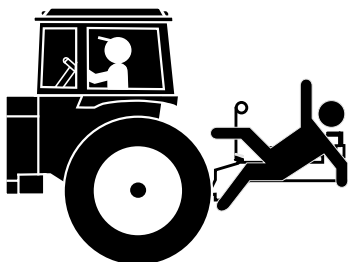

Practice Safe Maintenance

- ▲ Understand procedure before doing work. Use proper tools and equipment, refer to Operator's Manual for additional information.
- ▲ Work in a clean dry area.
- ▲ Lower the implement to the ground, put tractor in park, turn off engine and remove key before performing maintenance.

- ▲ Allow implement to cool completely.
- ▲ Do not grease or oil implement while it is in operation.
- ▲ Inspect all parts. Make sure parts are in good condition & installed properly.
- ▲ Remove buildup of grease, oil or debris.
- ▲ Remove all tools and unused parts from implement before operation.



Important Safety Information

These are common practices that may or may not be applicable to the products described in this manual.

Prepare for Emergencies

- ▲ Be prepared if a fire starts.
- ▲ Keep a first aid kit and fire extinguisher handy.
- ▲ Keep emergency numbers for doctor, ambulance, hospital and fire department near phone.

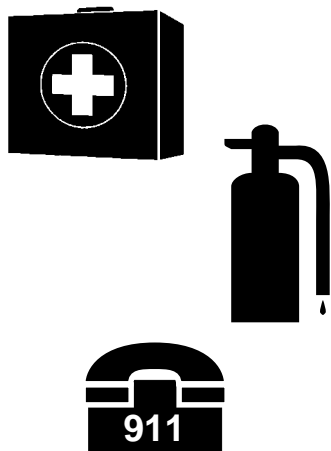
**Wear Protective Equipment**

- ▲ Protective clothing and equipment should be worn.
- ▲ Wear clothing and equipment appropriate for the job. Avoid loose fitting clothing.
- ▲ Prolonged exposure to loud noise can cause hearing impairment or hearing loss. Wear suitable hearing protection such as earmuffs or earplugs.
- ▲ Operating equipment safely requires the full attention of the operator. Avoid wearing radio headphones while operating machinery.

**Avoid High Pressure Fluids Hazard**

- ▲ Escaping fluid under pressure can penetrate the skin causing serious injury.
- ▲ Avoid the hazard by relieving pressure before disconnecting hydraulic lines.
- ▲ Use a piece of paper or cardboard, NOT BODY PARTS, to check for suspected leaks.
- ▲ Wear protective gloves and safety glasses or goggles when working with hydraulic systems.
- ▲ If an accident occurs, see a doctor immediately. Any fluid injected into the skin must be treated within a few hours or gangrene may result.

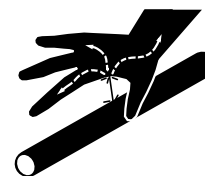

Important Safety Information

Safety Labels

Your Powered Rake comes equipped with all safety labels in place. They were designed to help you safely operate your implement. Read and follow their directions.

1. *Keep all safety labels clean and legible.*
2. *Replace all damaged or missing labels. To order new labels go to your nearest Land Pride dealer or visit our dealer locator at landpride.com.*
3. *Some new equipment installed during repair requires safety labels to be affixed to the replaced component as specified by Land Pride. When ordering new components make sure the correct safety labels are included in the request.*

4. *Refer to this section for proper label placement. To install new labels:*
 - a. *Clean the area the label is to be placed.*
 - b. *Spray soapy water on the surface where the label is to be placed.*
 - c. *Peel backing from label. Press firmly onto the surface.*
 - d. *Squeeze out air bubbles with the edge of a credit card.*

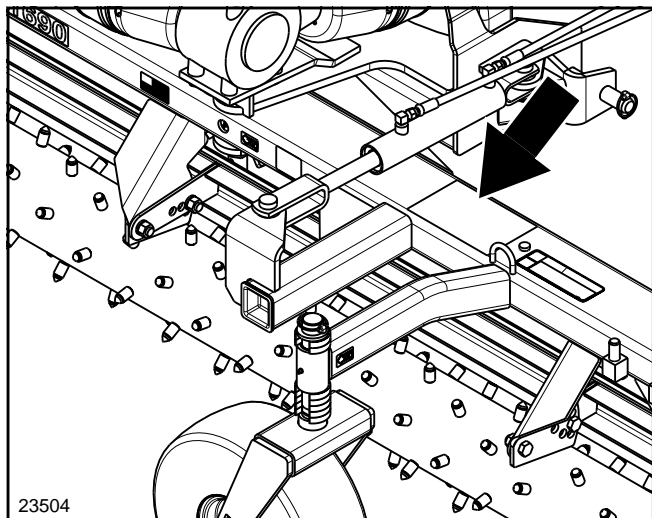

⚠ WARNING

To prevent Serious Injury or Death:

- Read Owner's Manual BEFORE using machine. (Contact Dealer for manuals.)
- Lower Power Rake to the ground, stop engine, set brake, remove key, and wait for all moving parts to stop BEFORE servicing, repairing, or adjusting.
- Keep Away from Power Rake when in operation.
- Keep others away from Power Rake when in operation. No riders allowed.
- Know how to stop tractor and equipment quickly.
- Ballast power unit per tractor's owner's manual.
- NEVER allow children or unqualified persons to operate equipment.
- Decrease speed when turning and use caution on uneven terrain.
- DO NOT operate Power Rake in transport position.
- Keep ALL safety shields and devices in place.
- Keep hands, feet, hair, and clothing away from moving parts.
- Escaping hydraulic fluid can cause serious injury.

818-255C Rev. 1

818-255C

Warning: General Safety

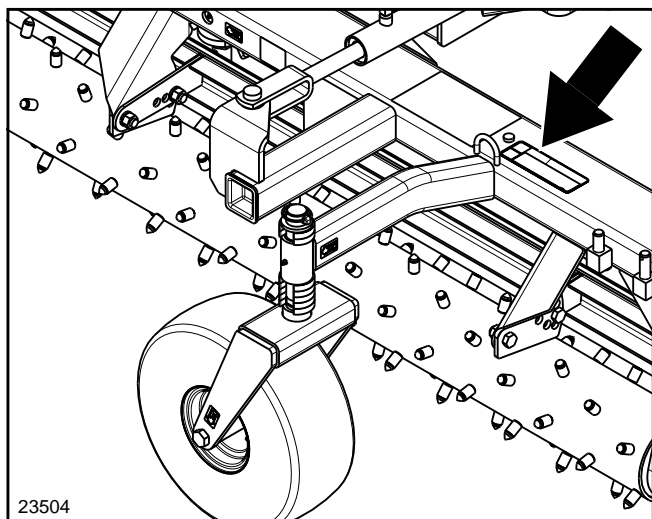

⚠ DANGER

ROTATING ROLLER HAZARD

KEEP AWAY

To Prevent Serious Injury or Death from Thrown Objects or Roller Contact:

- Do Not stand on or near machine when in operation.
- Keep others away.

818-254C Rev. 0

818-254C

Danger: Rotating Roller Hazard

Important Safety Information

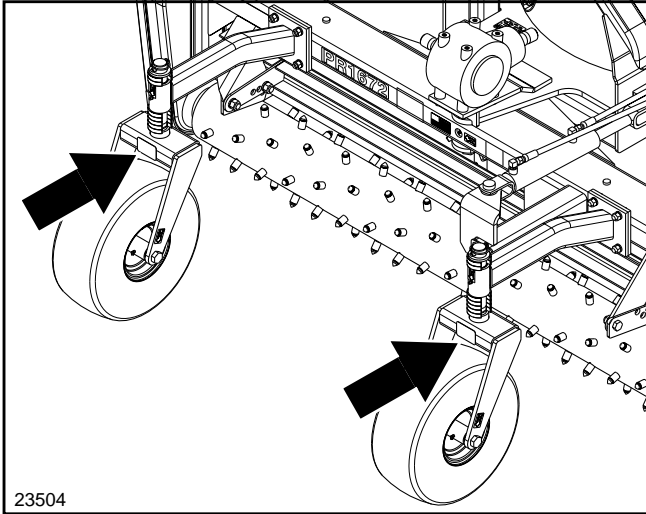

818-230C

Red Reflector

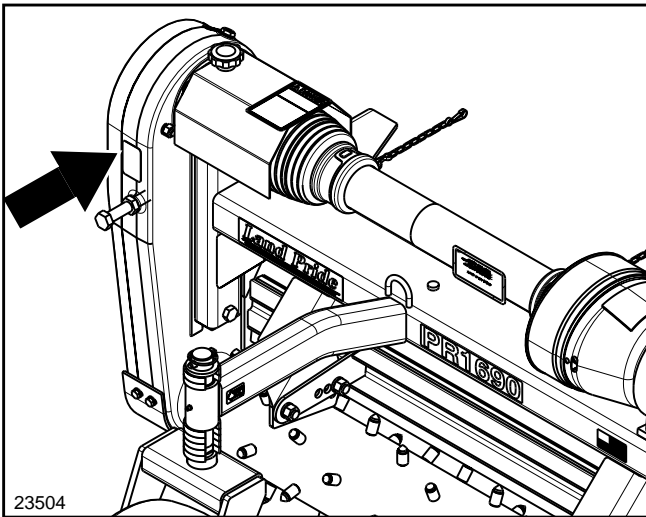

818-230C

Red Reflector
(PR1690 only)

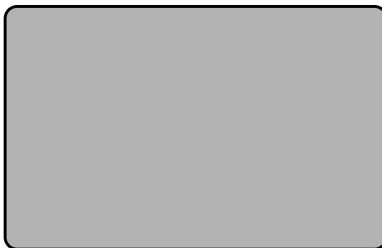
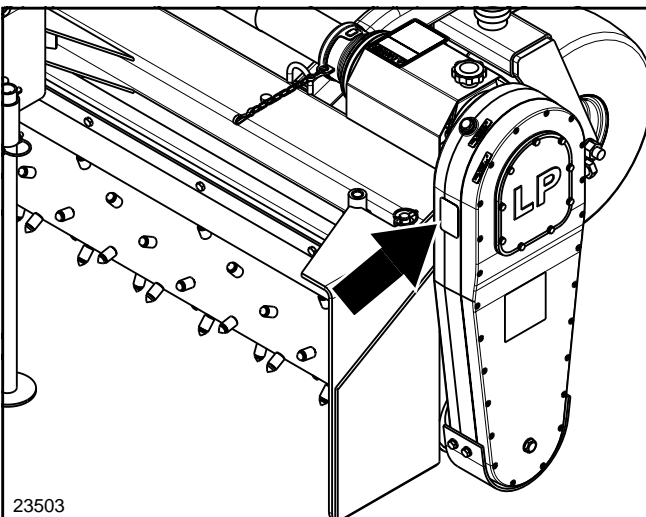

818-229C

Amber Reflector
(PR1690 only)

Important Safety Information

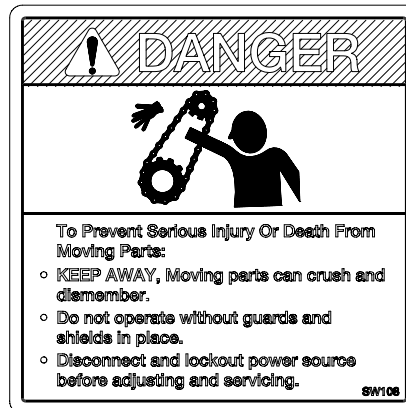
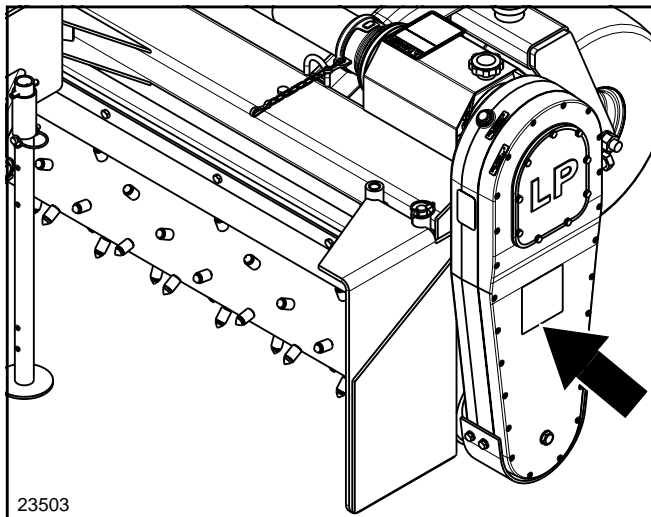

838-111C

Danger: Moving Parts

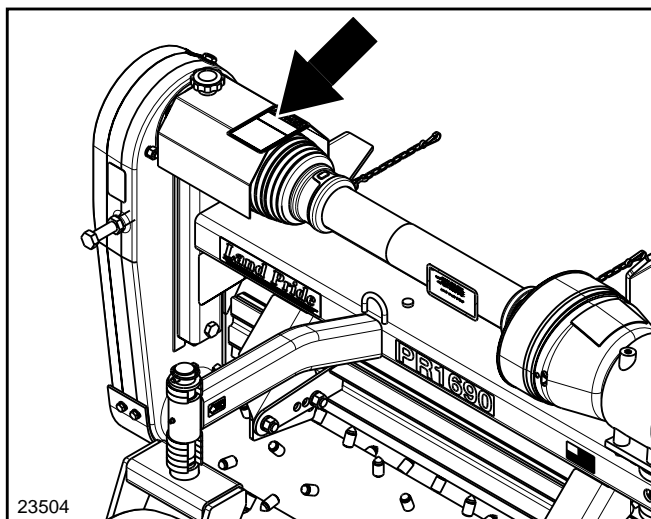

818-552C

Danger: Rotating Driveline

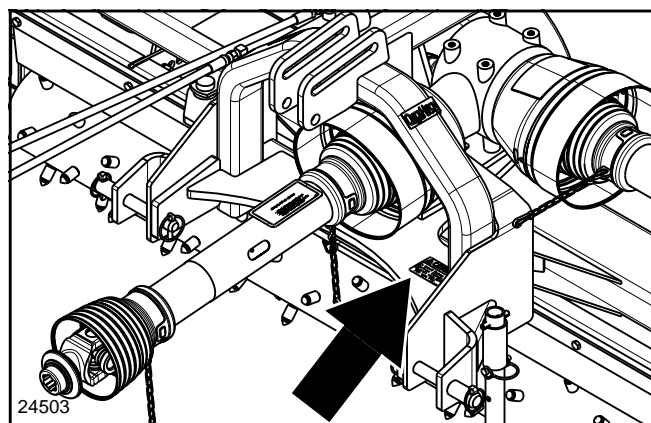

818-130C

Caution: 540 RPM

Important Safety Information

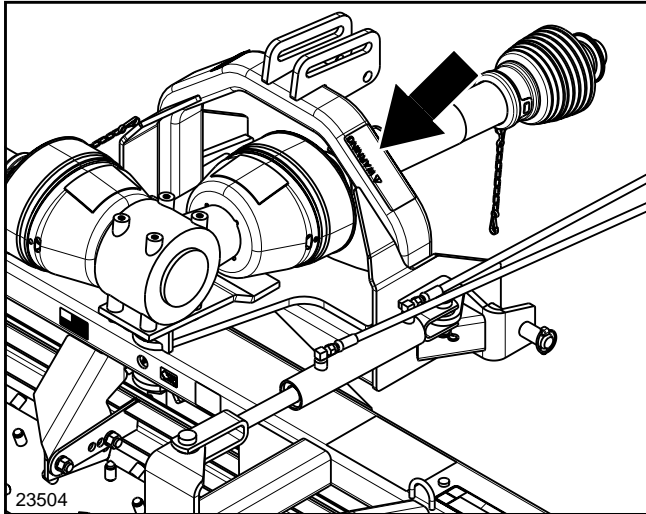

	<h1>WARNING</h1>
	<p>HIGH PRESSURE FLUID HAZARD</p> <p>To prevent serious injury or death:</p> <ul style="list-style-type: none"> • Relieve pressure on system before repairing or adjusting or disconnecting. • Wear proper hand and eye protection when searching for leaks. Use wood or cardboard instead of hands. • Keep all components in good repair. <p style="text-align: right;"><small>838-094C</small></p>

838-094C

Warning: High Pressure Fluid Hazard

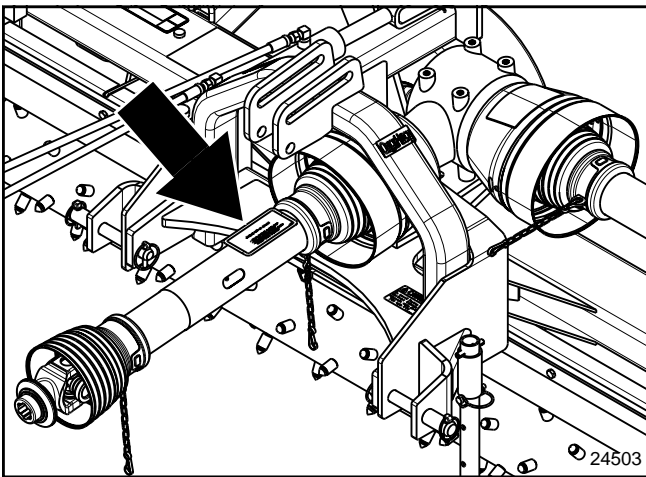

<h1>DANGER</h1>
<p>ROTATING DRIVELINE CONTACT CAN CAUSE DEATH KEEP AWAY! DO NOT OPERATE WITHOUT –</p> <ul style="list-style-type: none"> • All driveline guards, tractor and equipment shields in place • Drivelines securely attached at both ends. • Driveline guards that turn freely on Driveline <p style="text-align: right;"><small>818-552C</small></p>

818-552C

Danger: Rotating Driveline

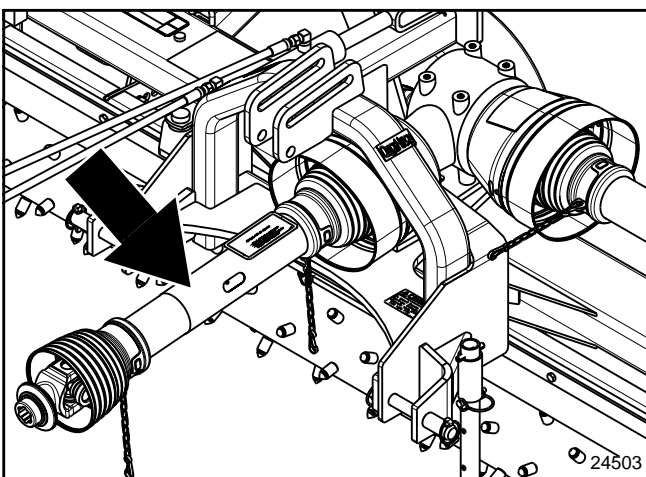

<h1>DANGER</h1>
<p>GUARD MISSING DO NOT OPERATE</p>
<h1>DANGER</h1>
<p>GUARD MISSING DO NOT OPERATE</p> <p style="text-align: right;"><small>818-540C</small></p>
<h1>DANGER</h1>

818-540C

Danger: Guard Missing
Located under driveline shields

Introduction

Land Pride welcomes you to the growing family of new product owners. This Powered Rake has been designed with care and built by skilled workers using quality materials. Proper assembly, maintenance and safe operating practices will help you get years of satisfactory use from the machine.

Application

The PR16 Series Powered Rakes are designed and built by Land Pride to be multi-functional seedbed and soil surface preparation tools for landscapers and turf care professionals. They are capable of grading, leveling, shaping, cultivating, renovating, and pulverizing various types of soil surfaces. They also are capable of raking and windrowing soil, rocks and construction site debris.

The 60" and 72" working widths are compatible with 25-40 HP Cat. I 540rpm PTO tractors while the 90" working width is compatible with 540 rpm PTO Cat. I and II tractors 35-75 HP. This means that Land Pride customers can choose models for either smaller "space restricted" landscaping and turf renovation jobs or all out "wide-area" renovation.

See "Features and Benefits", "Section 6" for additional information.

Using This Manual

- This Operator's Manual is designed to help familiarize you with safety, assembly, operation, adjustments, troubleshooting and maintenance. Read this manual and follow the recommendations to help ensure safe and efficient operation.
- The information contained within this manual was current at the time of printing. Some parts may change slightly to assure you of the best performance.
- To order a new Operator's or Parts Manual contact your authorized dealer. Manuals can also be downloaded, free-of-charge from our website at www.landpride.com or printed from the Land Pride Service & Support Center by your dealer.

Terminology

"Right" or "Left" as used in this manual is determined by facing the direction the machine will operate while in use unless otherwise stated.

Definitions

NOTE: A special point of information that the operator must be aware of before continuing.

IMPORTANT: A special point of information related to its preceding topic. Land Pride's intention is that this information should be read and noted before continuing.

Owner Assistance

The Warranty Registration card should be filled out by the dealer at the time of purchase. This information is necessary to provide you with quality customer service.

If customer service or repair parts are required contact a Land Pride dealer. A dealer has trained personnel, repair parts and equipment needed to service the Powered Rake.

The parts on your Powered Rake have been specially designed and should only be replaced with genuine Land Pride parts. Therefore, should your Powered Rake require replacement parts go to your Land Pride Dealer.

Serial Number Plate

Refer to Figure 1

For prompt service always use the serial number and model number when ordering parts from your Land Pride dealer. Be sure to include your serial and model numbers in correspondence also. The location of your serial number plate is on the back side of the main frame close to the gearbox. See arrow below.

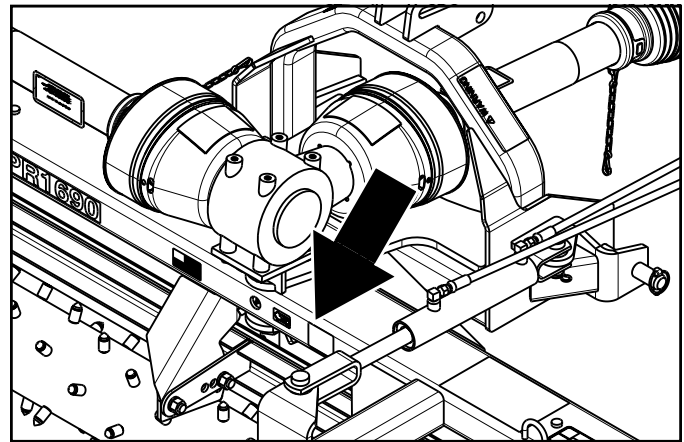

Serial Number Plate Location
Figure 1

Further Assistance

Your dealer wants you to be satisfied with your new Powered Rake. If for any reason you do not understand any part of this manual or are not satisfied with the service received, the following actions are suggested:

1. Discuss the matter with your dealership service manager making sure he is aware of any problems you may have and that he has had the opportunity to assist you.
2. If you are still not satisfied, seek out the owner or general manager of the dealership, explain the problem and request assistance.
3. For further assistance write to:

Land Pride
Service Department
P.O. Box 5060
Salina, KS 67402-5060

E-mail address
lp servicedept@landpride.com

Section 1: Assembly and Set-Up

Tractor Requirements

Tractor horsepower and weight must be capable of controlling the Powered Rake under all operating conditions. Tractors outside the horsepower range must not be used.

NOTE: Front tractor weights and/or ballast to tires may be required to offset weight of unit. Consult your tractor manual for details to install ballast weights.

- Models PR1660 & PR1672
 - Horsepower 25-40 HP
 - Hitch Type 3-Point
 - Hitch Category Cat. I
 - PTO Speed 540 RPM
 - Hydraulic (Optional) One Duplex Outlet

- Model PR1690
 - Horsepower 35-75 HP
 - Hitch Type 3-Point
 - Hitch Category Cat. I or II
 - PTO Speed 540 RPM
 - Hydraulic (Optional) One Duplex Outlet

Hydraulic Option

The Powered Rake may be purchased with either a ratchet jack or a hydraulic cylinder for angling. A duplex outlet is required for the hydraulic option to operate the double acting cylinder.

Tractor Hook-Up

Refer to Figure 1-1:

! DANGER

Tractor hook-up to equipment is dangerous and can result in serious injury or death. Do not allow anyone to stand between the Powered Rake and tractor during hook-up operations. Do not operate the hydraulic 3-point lift controls while someone is directly behind the tractor or near the Powered Rake.

Depending upon model of rake, a 3-Point Category I or Category II hitch is required. The lower 3-Point arms of the 3-Point hitch must be stabilized to prevent side-to-side movement. Most tractors have sway blocks or adjustable chains for this purpose.

Prepare as follows:

1. Determine your tractor's hitch category.
 - a. A **Category I** tractor will have a 7/8" dia. hole in the lower hitch links and a 3/4" dia. hole in the top link.
 - b. A **Category II** tractor will have a 1 1/8" dia. hole in the lower hitch links and a 1" dia hole in the top link.

2. Slowly back the tractor up to the Powered Rake and use the tractor's 3-point hydraulic control to align the lower hitch link holes with the clevis lug holes on the Powered Rake.
3. Engage tractor park brake, shut tractor engine off and remove key before dismounting from tractor.
4. With the tractor's lower hitch arms aligned and positioned in the clevises, attach lower arms to the clevises with hitch pins and secure with linchpins.
5. Connect top center link to the upper pivot hitch using customer supplied clevis pin and linchpin.
6. Stow jack stands in the raised position.
7. Return to the tractor and slowly operate the tractor's 3-Point hydraulic control up and down to check for clearance between tires, frame, drawbar, etc. Move or remove drawbar if it interferes with the Powered Rake.
8. Manually adjust one of the two lower lift arms up or down to level the Powered Rake from left to right.
9. Manually adjust length of the top-link to level the Powered Rake from front to rear.
10. Ensure that the lower arms are blocked to prevent excessive side movement.
11. Adjust tractor's lower lift arms to level the Powered Rake from left to right. Adjust top-link to level the Powered Rake from front to rear. A final adjustment will be made later.

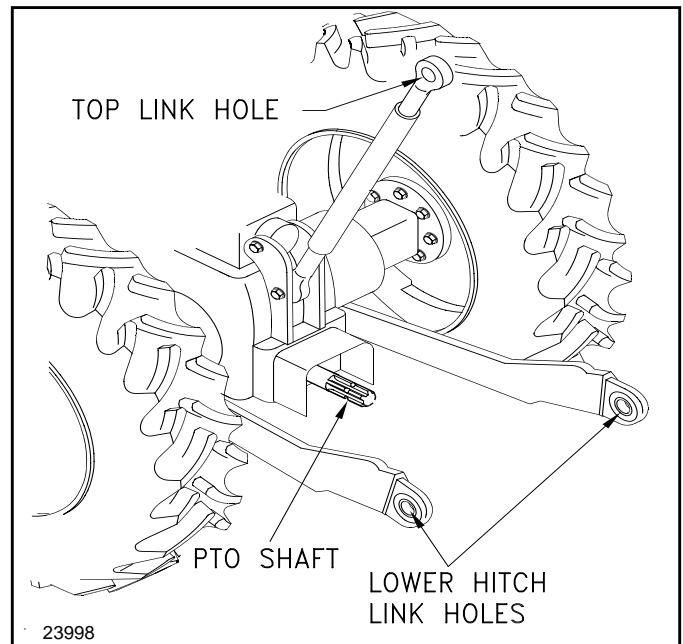

**Tractor 3-Point Hitch
Figure 1-1**

Section 1: Assembly and Set-Up

PTO Hook-Up

If the Powered Rake is to be used on more than one tractor, an additional PTO shaft may be required - especially if a quick hitch is used.



CAUTION

Do not use a PTO adaptor with a quick hitch. A PTO adaptor will increase the strain on the tractor's PTO shaft and can damage the PTO shaft and driveline.

IMPORTANT: Some tractors are equipped with multi-speed PTO ranges. Be certain your tractor's PTO is set for 540 rpm.

IMPORTANT: Avoid premature driveline breakdown. A driveline that is operating **must not exceed** an angle of 25 degrees up or down while operating the 3-point lift. See Figure 1-2 below.

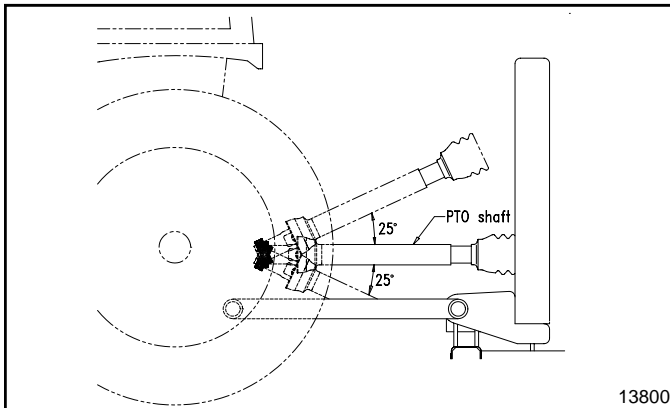

Maximum PTO driveline Movement During Operation
Figure 1-2

IMPORTANT: The PTO driveline may be too long for some tractors. If the Powered Rake is used on more than one tractor, an additional PTO driveline may be required.

IMPORTANT: Aligning the tractor's PTO shaft level with the Powered Rake's PTO shaft is necessary when checking to see if the driveline will fit correctly between tractor and Powered Rake.

Refer to Figure 1-3:

1. Start tractor and slowly engage tractor's hydraulic 3-point to lift lower arms until the Powered Rake's driveline shaft is approximately level with tractor's PTO shaft.
2. Slide outer yoke end of driveline over the tractor's PTO shaft and secure with the locking collar. Skip to step 4 if driveline fits between tractor and Powered Rake.

3. The driveline will require shortening if it is too long to fit between tractor and Powered Rake. Shorten driveline as follows:

- a. Raise 3-point lower arms until Powered Rake and tractor PTO shafts are approximately level with each other. Securely block Powered Rake frame in this position. Set tractor in park, shut tractor engine off, set park brake and remove switch key.
- b. Pull driveline apart into two sections as shown in Figure 1-3. Attach outer driveline universal joint to the tractor PTO shaft and inner driveline universal joint to the Powered Rake gearbox shaft. Pull on each driveline section to be sure the universal joints are secured to the shafts.
- c. Hold driveline sections parallel to each other to determine if they are too long. The inner and outer shields on each section should end approximately 1" short of reaching the universal joint shield on the adjacent section (see "B" dimension). If they are too long, measure 1" ("B" dimension) back from the universal joint shield and make a mark at this location on the inner and outer driveline shields.
- d. Cut off the inner shield at the mark ("X" dimension). Cut the same amount off the inner shaft ("X1" dimension). Repeat cut off procedure ("Y" & "Y1" dimensions) to the outer driveline half.
- e. Remove all burrs and cuttings.
- f. Apply multi-purpose grease to the inside of the outer shaft and reassemble the driveline.
- g. Attach inner driveline yoke end to the Powered Rake gearbox input shaft.
- h. Attach outer driveline yoke end to the tractor's PTO shaft.

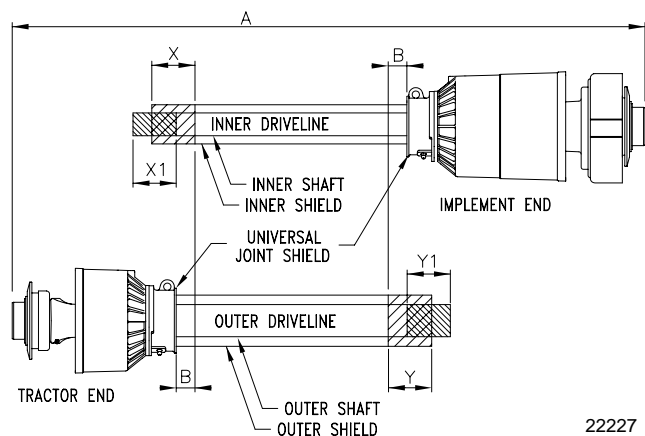

Driveline Shortening
Figure 1-3

4. The driveline should now be moved back and forth to insure that both ends are secured to the tractor and Powered Rake PTO shafts. Reattach any end that is loose.

Section 1: Assembly and Set-Up

IMPORTANT: A small chain is supplied with the driveline. This chain must be attached to the inner driveline shield and to the Powered Rake to restrict shield rotation.

5. Hook driveline safety chain in the hole in the inner driveline guard. Attach the other end to the Powered Rake's main frame.
6. Start tractor and raise Powered Rake just enough to remove blocks used to support the deck in step 3a.
7. Slowly engage the tractor's hydraulic 3-point to lower the Powered Rake. Check for sufficient drawbar clearance. Move drawbar ahead, aside or remove if required.

Hydraulic Hook-up (Optional)



DANGER

Hydraulic fluid under pressure can penetrate skin. Wear protective gloves and safety glasses or goggles when working with hydraulic systems. Use a piece of cardboard or wood rather than hands when searching for hydraulic leaks. If hydraulic fluid is injected into the skin, it must be treated by a doctor within a few hours or gangrene may result.

1. Attach hydraulic couplers (supplied by the customer) to the end of hydraulic hoses.
1. Connect hydraulic hoses to tractor remote duplex outlet. The hoses on each outlet should be connected such that when the control lever is pushed "forward", the right side rotates forward. If the lever operates in reverse, change hose hook-up at the duplex receptacle.
2. Cycle hydraulic system by cycling the hydraulic cylinder several times. It may be necessary to purge the system of trapped air if operation remains sluggish. The system may be purged as follows:
 - a. With the tractor shut off and the Powered Rake resting on the ground, loosen the hydraulic hose fitting at the cylinder slightly to allow fluid to escape.
 - b. Slowly activate tractor control valve to purge any trapped air from the system.
 - c. Tighten each fitting once the system has been purged.

Section 2: Operating

Operating Check List

Hazard control and accident prevention are dependent upon the awareness, concern, prudence and proper training involved in the operation, transport, maintenance and storage of the Powered Rake. Therefore, it is absolutely essential that no one operates the Powered Rake without first having read, fully understood and become totally familiar with the Operator's Manual. Make sure the operator has paid particular attention to:

- **Important Safety Information**, pages 1 to 6
- **Section 1: Assembly and Set-Up**, page 9
- **Section 2: Operating**, page 12
- **Section 3: Adjustments**, page 14
- **Section 4: Maintenance & Lubrication**, page 16

Before beginning to operate your Powered Rake the following inspection should be performed.

Operating Checklist

✓	Check	Ref Pages
	Make sure all guards and shields are in place and secured.	1
	Read all of the <i>Hook Up</i> instructions.	9 to 11
	Read " Operating Instructions "	12
	Check chain tension.	15
	Check chain tension. Refer to "Drive Chain Adjustment".	18
	Grease driveline shaft and other grease fittings.	21
	Check oil level in gearbox and chain case.	22
	Make certain that all oil plugs have been replaced properly in both the gearbox and chain case.	22
	Check initially and periodically for loose bolts & pins, and chains. Refer to <i>Torque Values Chart</i> .	26
	Check air pressure in gauge wheel tires.	26

Make the following inspections after attaching the Powered Rake to the tractor. Make certain the PTO is disengaged and completely stopped before continuing.

1. Inspect tractor safety equipment to make sure it is in good working condition.
2. Carefully raise and lower the implement with the Powered Rake set at the maximum 15 degree angle to ensure that the drawbar, tires, and other equipment on the tractor do not contact the frame or PTO driveline.
3. Check all hoses and wires to be sure that they will not contact PTO driveline. Check PTO guards to make certain they are in good condition and in place.

4. Inspect hydraulic hoses for wear, damage and hydraulic leaks. See "Avoid High Pressure Fluids Hazard" on page 3. Replace damaged and worn hoses with genuine Land Pride parts.
5. Set tractor throttle to idle or slightly above idle and slowly engage the PTO. Once the Powered Rake is running smoothly, increase tractor PTO speed to the rated PTO speed. Stop PTO rotation immediately if vibration occurs. Wait for the PTO to come to a complete stop and then dismount from the tractor to check for probable causes.

IMPORTANT: Do not exceed 540 RPM rated PTO speed. Excessive engine speed will cause damage to the power train components.

Transporting

IMPORTANT: ALWAYS disengage PTO before raising the Powered Rake to transport position.

1. Be sure that the driveline does not contact tractor or Powered Rake when raising the Powered Rake to the transport position.
2. Be sure to reduce tractor ground speed when turning; and to leave enough clearance between the Powered Rake and other obstacles such as buildings, trees or fences to prevent damage from contacting them.
3. Select a safe ground speed when transporting from one area to another. When traveling on roadways, transport in such a way that faster moving vehicles may pass you safely.
4. Shift tractor to a lower gear when traveling over rough or hilly terrain.

CAUTION

Use accessory lights and other devices for adequate warning to operators of other vehicles when traveling on public roads at all times during the day and night. Comply with all federal, state and local laws.

Operating Instructions

CAUTION

Keep bystanders at least 20 feet away when operating!

DANGER

Do not operate the hydraulic 3-point lift controls while someone is directly behind the tractor or near the Powered Rake.

DANGER

Do not operate the hydraulic cylinder controls while someone is directly behind the tractor or near the Powered Rake.

Section 2: Operating

Operating Instructions continued

First completely familiarize yourself with the Operator's Manual. Then complete the Operator's checklist, properly attach the Powered Rake to your tractor, make initial depth setting, level settings and roller angle adjustments.

After completing the above, you will need to choose a work site, perform operational safety checks and make final adjustments before using your Land Pride Powered Rake.

IMPORTANT: Shut off all power, disengage PTO, set park brake and remove ignition key any time the Powered Rake is not operating properly or needs adjustment.

It's now time for a running operational safety check. Make certain that the tractor's park brake is engaged, PTO is disengaged and the Powered Rake is resting on the ground. Start the tractor and back off engine rpm to approximately one-quarter throttle. Using the rear draft link hydraulic control, lift the Powered Rake about half way off the ground and then engage the rear PTO. If everything is running smoothly, increase throttle speed until you have reached full operating speed. Never engage the tractor PTO at full engine rpm., damage to the driveline and/or Powered Rake could occur.

To make final adjustments, choose a work site that is dry and allows you to make at least a 50 ft. straight run. Raise the Powered Rake half way off the ground, disengage the tractor PTO, release the park brake and travel to your starting point. Travel speed should be between 3 and 5 mph.

Once at the site, idle the tractor engine, engage the PTO and then increase engine speed until the tractor is at full 540 rpm operating speed. Begin traveling forward while gently lowering the running Powered Rake to the ground. Make slight changes to the tractor's ground speed as you travel forward to determine the desired ground finish. Generally, a slower speed results in a finer finish, while a higher speed results in a coarser finish. Excessive ground speed may result in dirt or material passing over the top of the material control deflector or too much material being windrowed off to the side. Powered Rakes do not perform well in wet sticky soil. Avoid making sharp turns or backing-up when in contact with the ground.

Normal operating rake angle is 15 degrees left or right. However, you may want to make subtle hydraulic adjustments to the roller angle to determine varying effect on the surface finish.

You can also vary the effect on the surface finish by setting the material control deflector height above the roller. The material control deflector sifts out clods, rocks and other debris as the soil passes over the top of the roller. Adjusting the blade down decreases the gap between the deflector and roller and will sift out more objects for a finer soil finish. Adjusting the blade up

allows more clods, rocks and debris to pass over the roller and produces a coarser soil finish.

Set the working depth and level the rake at the caster gauge wheels and not with the tractor. Normally a one-inch cultivation depth is considered ideal for a surface finish. Make adjustments to the working depth if too many rocks or excessive debris pass under the roller by changing the C-spacers on the gauge wheel spindles. Increase working depth by moving the spacers from below the support arms to above the support arms. Decrease working depth by moving the spacers from above the gauge wheel support arms to below the support arms.

The Powered Rake should also be set to operate level. It has a tendency to go in deeper on the driveline side (left side) because that is the heavy side of the rake. Compensate for this by changing the C-spacers on the right gauge wheel so that it is set approximately 1" deeper than the left gauge wheel.

After you have traveled 50 feet, properly shut down the tractor and Powered Rake to inspect the finish and determine what, if any, additional adjustments need to be made. Check for any foreign objects that may be wrapped around the roller or lodged between moving parts.

Remember that the right finish is achieved through a combination of proper soil moisture conditions, operating depth, ground speed, material control deflector opening and roller angle. Your Powered Raking capabilities will improve rapidly with experience.

Section 3: Adjustments

Gauge Wheels

Refer to Figure 3-1

Caster type gauge wheels are mounted on the rake to control roller height during field operation. Do not use tractor to control roller height.

Set working depth of the Powered Rake by moving the gauge wheels up for greater depth and down for less depth. Move wheels up by repositioning the desired number of C-spacers located on the gauge wheel spindles from below the support arms to above the support arms or from above the support arms to below the support arms to move the wheels down. For best results, set the gauge wheel on the chain case side approximately one inch lower than the non-drive side to allow for additional weight on the chain case side.

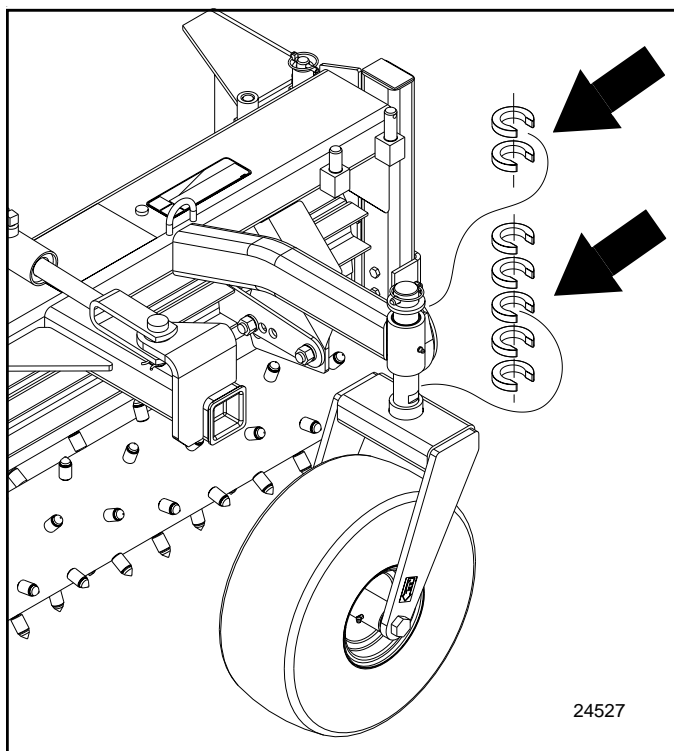

Depth Adjustment
Figure 3-1

Rake Angle

The roller frame can be angled a maximum of 15 degrees in either direction for windrowing material to the side. Angling is accomplished with either a hydraulic cylinder or a ratchet jack.

Adjust rake angle with a ratchet jack by setting the ratchet mechanism on the jack and then pumping the jack handle.



DANGER

Do not operate the hydraulic cylinder controls while someone is directly behind the tractor or near the Powered Rake.

Adjust rake angle with the hydraulic cylinder by operating the control lever at the tractor. The hydraulic cylinder option is very useful when changing rake angle often. You may order a hydraulic cylinder from your nearest Land Pride dealer or visit our dealer locator at landpride.com.

Material Control Deflector

Refer to Figure 3-2

A material control deflector mounted above the rake roller controls both size and shape of material being raked by adjusting the height of the deflector above the roller. The highest position or widest gap allows most dirt and rock to pass over the roller and lowering the deflector height or narrowing the gap produces a finer raking job.

Reposition the height of the material control deflector (C) by loosening at both ends bolts (A) and repositioning bolts (B) to a different deflector height location.

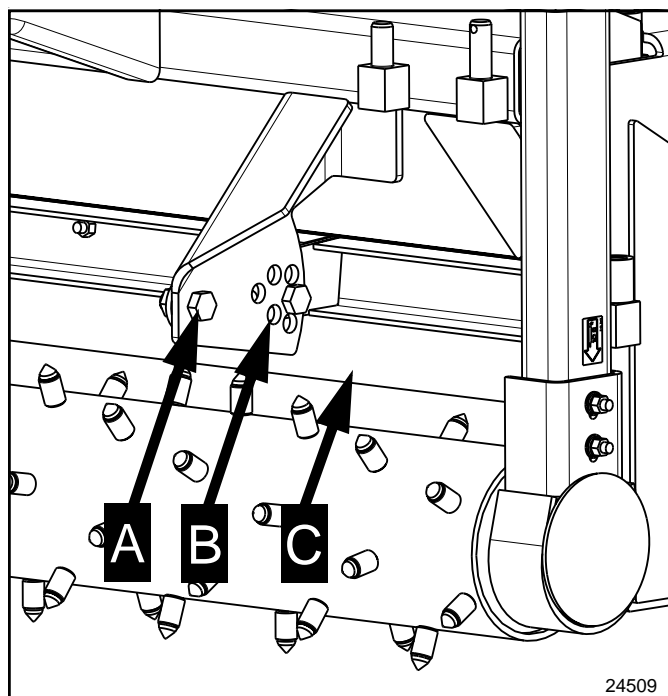

Material Control Deflector Adjustment
Figure 3-2

Section 3: Adjustments

Drive Chain Adjustment

Refer to Figure 3-3

CAUTION

BEFORE any maintenance is performed, lower the Powered Rake to the ground, stop tractor engine and remove ignition key. DO NOT make maintenance adjustments while tractor is running.

1. Check chain tension by removing 1/4" x 5/8" hex bolts (#4), lockwashers (#9) and access cover (#2) from the chain case.
2. Inspect chain for tightness and excess wear. Replace worn out chains. See "Sprocket and Drive Chain Replacement" page 19.
3. Tension a loose chain by turning the take-up bolt (#5) clockwise. Don't over tension. See note below.

NOTE: Do not over tension roller chain. Roller chain should be tightened with a slight amount of slack. A chain tensioned too tight will increase sprocket and chain wear.

4. Turn tension roller several turns and observe the chain to make sure everything is working properly.
5. Apply 1/8" bead of Land Pride No. 821-049C sealant on the surface of the main cover (#1) in location where the access cover (#2) contacts the main cover (#1). Reinstall access cover (#2) and secure with lockwashers (#9) and 1/4"-20 x 5/8" GR5 hex bolts (#4). Torque hex bolts to correct torque.

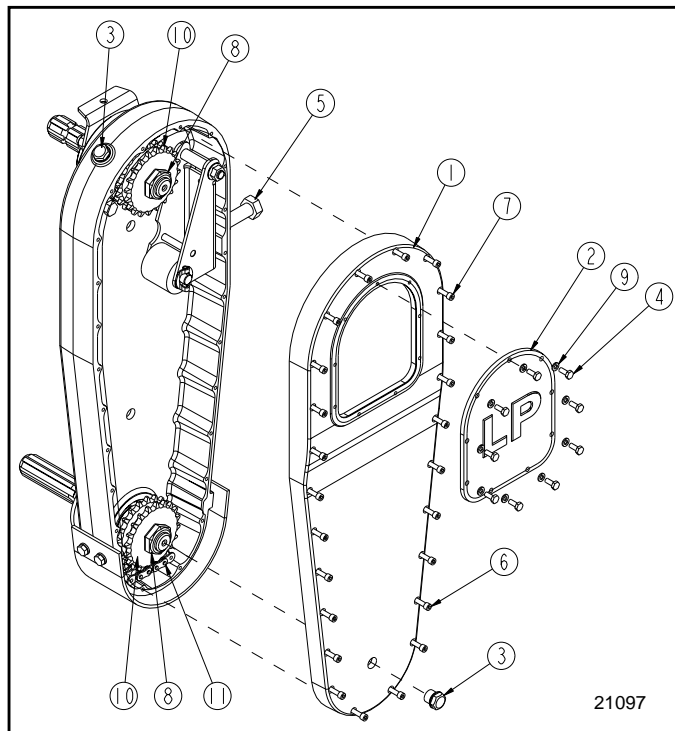

**Drive Chain Adjustment
Figure 3-3**

End Plates

Refer to Figure 3-4

End plates (#1) & (#2) are utilized to collect rocks and debris in front of the roller for the purpose of distributing material over low areas. They can be removed and stored on the right hand side of the rake by removing the linch pins (#3) containing the plates and reposition the plates on top side of the right end of the rake as shown below. Secure by reinserting the linch pins (#3).

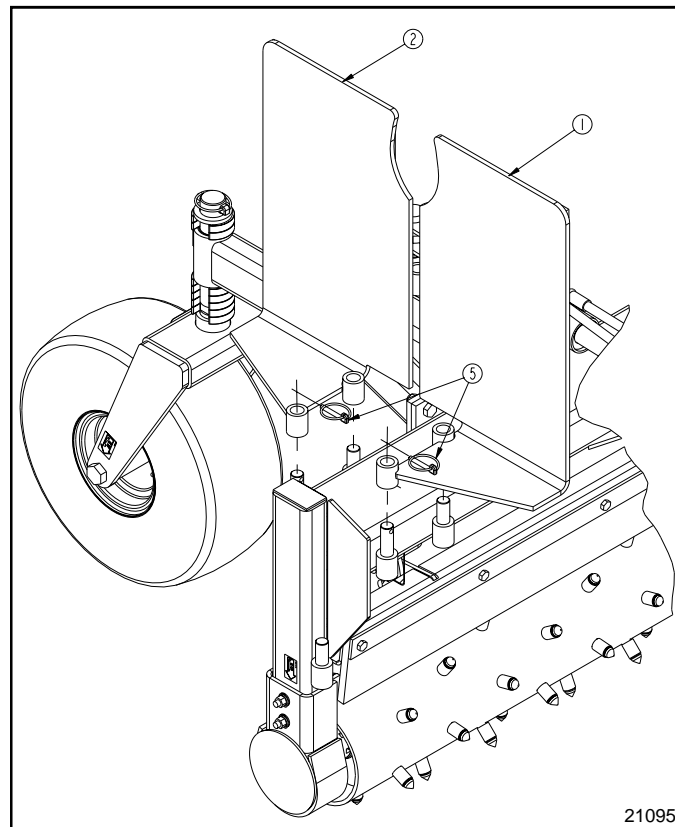

**End Plates (Shown in stored position)
Figure 3-4**

Section 4: Maintenance & Lubrication

Maintenance

Proper servicing and adjustment is the key to the long life of any implement. With careful and systematic inspection, you can avoid costly maintenance, time and repair.

After using your Powered Rake for several hours, check all bolts to be sure they are tight.

Replace any worn, damaged or illegible safety labels by obtaining new labels from your Land Pride Dealer.



CAUTION

BEFORE any maintenance is performed, lower the Powered Rake to the ground, stop tractor engine and remove ignition key. **DO NOT** attempt to make maintenance adjustments while tractor is running.

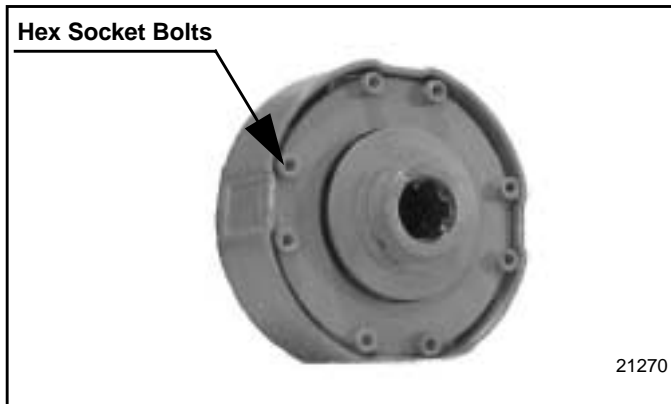

Slip Clutch with Hex Socket Bolts
Figure 4-1

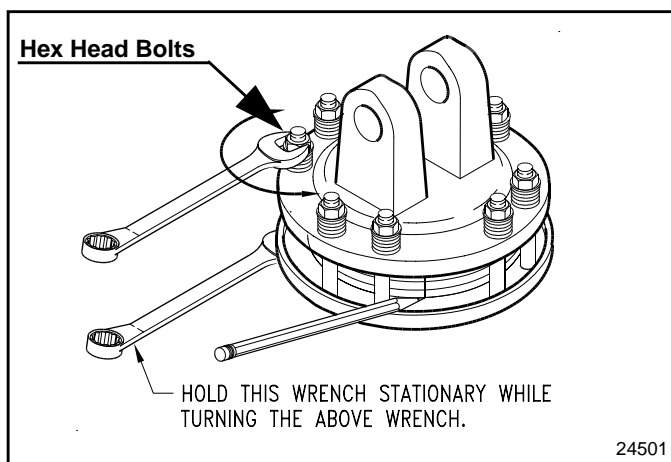

Slip Clutch with Hex Head Bolts
Figure 4-2

Slip Clutch Maintenance

Slip clutches should be "run-in" prior to initial operation and after long periods of inactivity. To prevent driveline and gearbox damage, repeat "Run-In" instructions at the beginning of each season and when moisture and/or condensation seizes the inner friction disks.

Your Powered Rake will have one of two types of slip clutches. One is adjustable with hex socket bolts and the other is adjustable with hex head bolts. Refer to Figure 4-1 and Figure 4-2 to determine which slip clutch your Powered Rake has. Follow run-in and assembly instructions for your particular slip below.

Slip Clutch with Hex Socket Bolts

If your clutch has enclosed friction disks and is tensioned with hex socket bolts as shown in Figure 4-1, follow clutch run-in and assembly instructions below.

If your clutch has exposed friction disks and is tensioned with hex head bolts as shown in Figure 4-2, skip to "Slip Clutch with Hex Head Bolts" on page 17.

Clutch Run-in (with hex socket bolts)

Refer to Figure 4-1:

1. Loosen counterclockwise all 8 hex socket bolts uniformly 6 full turns.
2. Cycle clutch on and off 5 or 6 times (15 seconds on and 15 seconds off) with the engine operating at half throttle.
3. Tighten clockwise all 8 hex socket bolts fully back. Clutch is ready for use.

Clutch Assembly (with hex socket bolts)

Refer to Figure 4-3 on page 17:

If clutch run-in indicated that one or more of the friction disks did not slip, then the clutch must be disassembled into separate parts.

1. Rotate the 8 hex head socket bolts (#4) all the way out to free stop flange (#5).
2. Rotate stop flange (#5) and remove from housing (#1)
3. Remove the following inner components:
 - a. Spring kit (#6)
 - b. Pressure flange (#7)
 - c. 1st Friction disk (#8)
 - d. Hub with flange and pull collar (#2 & #3)
 - e. 2nd Friction disk (#8)
 - f. Bearing (#9)
4. Inspect all components and replace to their original position. Make certain stop flange (#5) is replaced with its flange down as shown.
5. Fully tighten all 8 hex socket bolts (#4).

Section 4: Maintenance & Lubrication

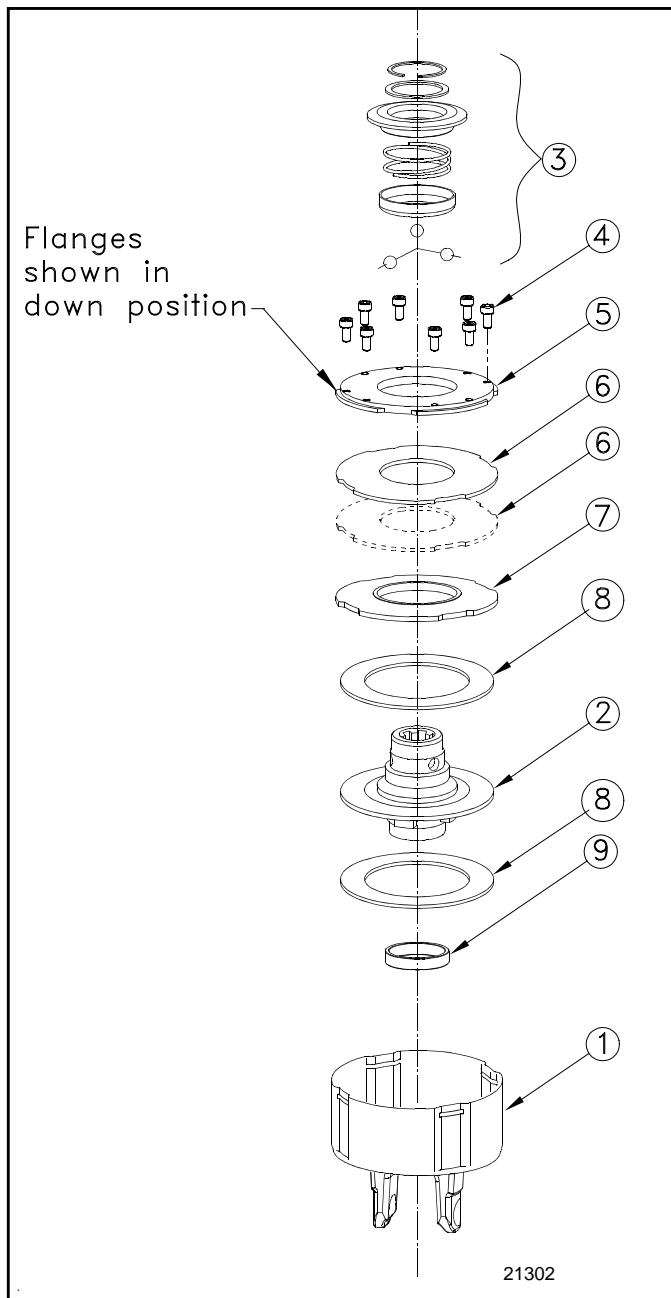

Clutch Assembly
Figure 4-3

Slip Clutch with Hex Head Bolts

If your clutch has exposed friction disks and is tensioned with hex head bolts as shown in Figure 4-4, follow clutch run-in and assembly instructions below.

If your clutch has enclosed friction disks and is tensioned with hex socket bolts as shown in Figure 4-1 on page 16, follow instructions for "Slip Clutch with Hex Socket Bolts" on page 16.

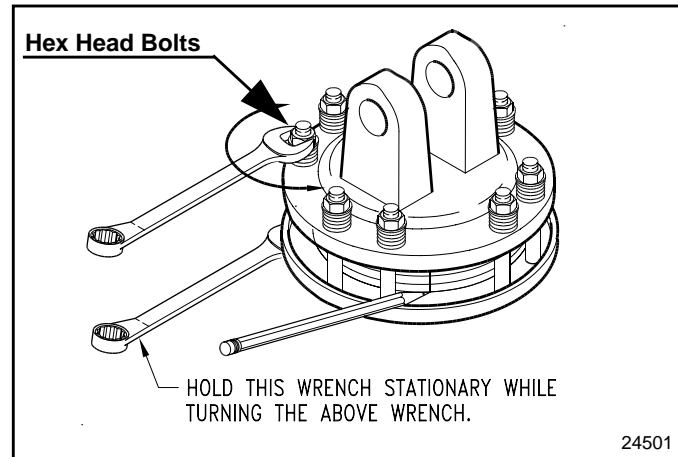

Slip Clutch with Hex Head Bolts
Figure 4-4

Clutch Run-In (with hex head bolts)

Refer to Figure 4-4:

1. Using a pencil or other marker, scribe a line across the exposed edges of the clutch plates and friction disks.
2. Carefully loosen each of the 8 spring retainer nuts by exactly 2 revolutions. It will be necessary to hold the hex end of the retainer bolt in order to count the exact number of revolutions.
3. Cycle clutch on and off 2 times (2 to 3 seconds on and 15 seconds off) with the engine operating at half throttle.
4. Inspect the clutch and ensure that the scribed markings made on the friction disks and plate have changed position. Slippage has not occurred if any two marks on the friction disks and plate are still aligned. A clutch that has not slipped must be disassembled into separate parts. See Clutch Assembly (with hex head bolts) on page 18 to disassemble this clutch.
5. Tighten each of the 8 spring retainer nuts on the clutch housing exactly 2 revolutions to restore the clutch to the original setting pressure. See Step 7 and Figure 4-6 on page 18 for correct compressed spring length.

Section 4: Maintenance & Lubrication

Clutch Assembly (with hex head bolts)

Refer to Figure 4-5

If clutch run-in indicated that one or more of the friction disks did not slip, then the clutch must be disassembled to separate parts.

1. Remove spring retainer nuts (#9a), springs (#2) and bolts (#9b) from the assembly.
2. Each friction disk (#5) must then be separated from the metal surface adjacent to it.
3. Inspect all parts for excessive wear and condition. Clean all parts that do not require replacement.
 - The original disk thickness is 1/8" and should be replaced if thickness falls below 3/32".
 - If the clutch has slipped to the point of "smoking", the friction disks may be damaged and should be replaced. Heat build-up may also affect the yoke joints.

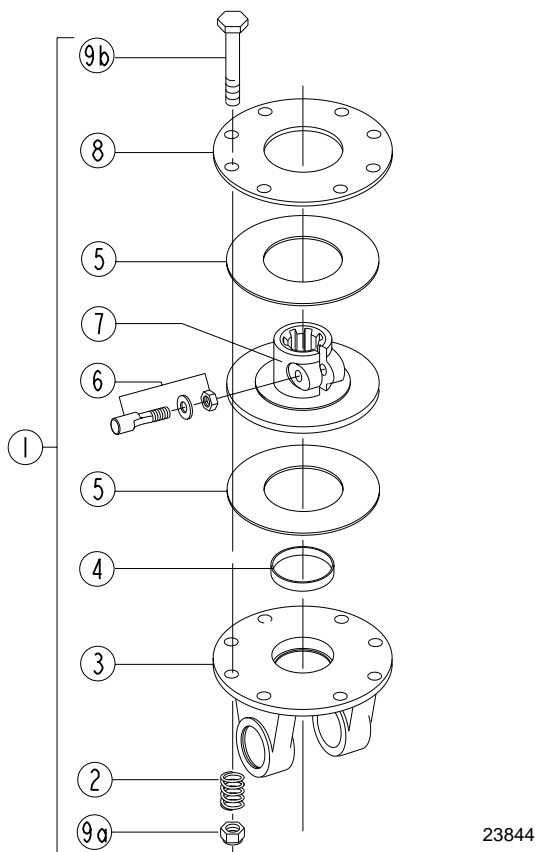

Clutch Assembly
Figure 4-5

4. Reassemble each friction disk (#5) next to the metal plate it was separated from.
5. Make certain bushing #4 is positioned as shown. Install bolts (#9b) through the end plates and intermediate plates as shown.
6. Place springs (#2) over the bolts and secure with nuts (#9a).

Refer to Figure 4-6

7. Progressively tighten each spring retainer bolt until correct compressed spring length "A" is reached.
 - A = 1.26"

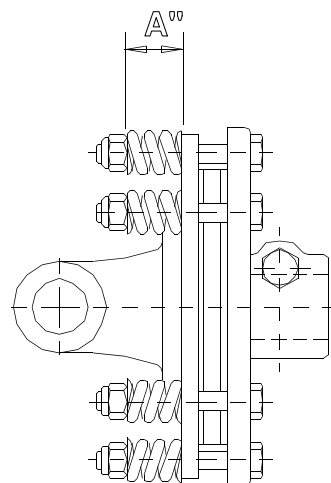

23997

Clutch Adjustment
Figure 4-6

Drive Chain Maintenance

Refer to Figure 4-7

The operator should check chain tightness after initial run in and periodically thereafter to make sure that the drive chain is tensioned correctly. If adjustment is needed refer to "Drive Chain Adjustment" on page 15.

Chain Case Skid Shoe Replacement

1. Replace chain case skid shoe (#1) by removing four 3/8" x 3/4" hex head bolts (#2) and lockwashers (#3).
2. Replace worn skid shoe with new shoe.
3. Secure skid shoe (#1) with 3/8" lockwashers (#3) and four 3/8" x 3/4" hex head bolts (#2).
4. Torque hex bolts to correct torque.

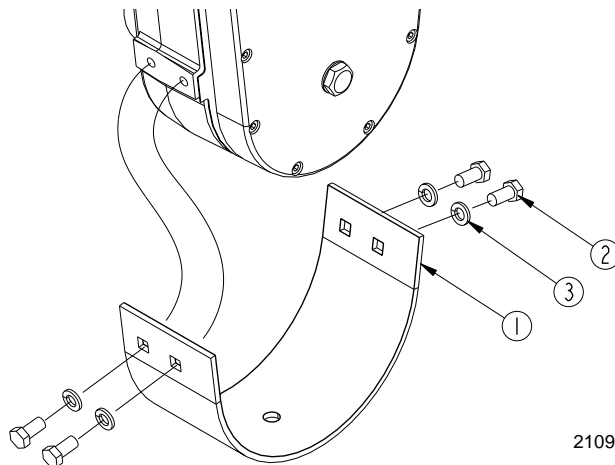

21096

Chain Case Skid Shoe Replacement
Figure 4-7

Section 4: Maintenance & Lubrication

Sprocket and Chain Replacement

Refer to Figure 4-8:

1. Remove 1/4" x 1 1/4" and 1/4" x 1 1/2" hex socket cap screws (#6 & #7).
2. Remove main cover plate (#1).

NOTE: Oil in chain case! Be prepared to capture oil when taking off bottom cover.

3. Loosen chain tension by turning chain tension take-up bolt (#5) counterclockwise.
4. Remove nuts (#8) retaining sprockets (#10).
5. Remove sprockets (#10) and chain (#11).
6. Install new chain and sprockets.
7. Reinstall sprocket retaining nuts (#8) and properly torque.

8. Tension idler roller by tightening take-up bolt (#5). See "Drive Chain Adjustment" on page 15 for detailed chain take-up instructions.
9. Turn tension roller several turns and observe roller chain to make sure everything is working properly.
10. Apply 1/8" bead of Land Pride No. 821-049C sealant on the edge of the chain case housing in the location where the main cover plate (#1) will contact the chain case. Reinstall main cover plate (#1) with 1/4" -20 x 1 1/4" GR2 and 1/4" -20 x 1 1/2" GR2 hex socket cap screws (#6 & #7). Torque to correct tension.
11. Remove top and bottom plugs (#3). Fill Chain case with Shell Alvania EP00 gear lube (Land Pride No. 821-045C) through top plug hole until oil escapes out bottom plug hole. (Equivalent to 2 1/2 pints.)
12. Reinstall and tighten top and bottom plugs (#3).

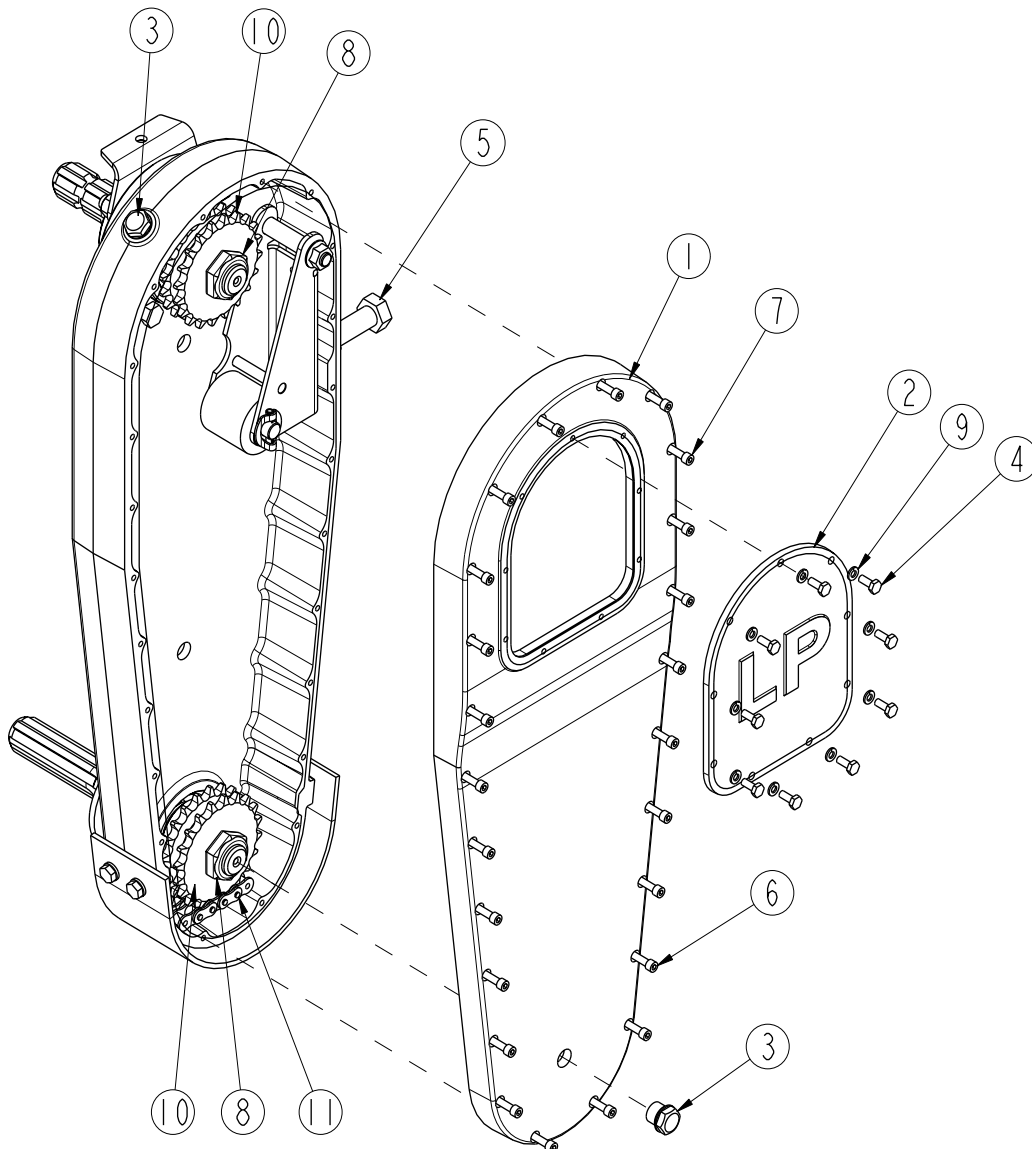

21097

Sprocket and Drive Chain Replacement
Figure 4-8

Section 4: Maintenance & Lubrication

Storage

At the end of the working season or when the Powered Rake will not be used for a long period, it is good practice to clean off any dirt or grease that may have accumulated on any of the moving parts.

Check roller studs for wear and replace if necessary.

Inspect Powered Rake for loose, damaged or worn parts. Adjust and tighten loose parts or replace if needed.

Lubricate as noted in "**Lubrication**" on page 21.

Repaint parts where paint is worn or scratched to prevent rust.





Drain gearbox and chain case oil. Drain oil in gearbox by removing bottom drain plug. Drain oil in chain case by removing large cover (#1) Figure 3-3. Be sure to refill gearbox and chain case at this time. See "**Lubrication**" on page 15.

Apply a light coat of grease to any exposed hydraulic cylinder rods.



Store Powered Rake in a clean, dry place.

Section 4: Maintenance & Lubrication

Lubrication

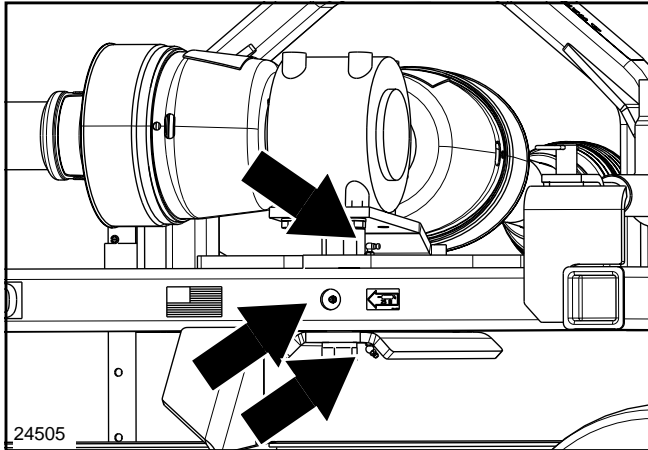
Lubrication Legend	 Multi-purpose spray lube	 Multi-purpose grease lube	 Multi-purpose oil lube	 Intervals in hours at which lubrication is required



	 25 Hours
---	---



Pivot

Grease pivot point every 25 hours
Three grease zerks

Type of Lubrication: Multi-Purpose Grease

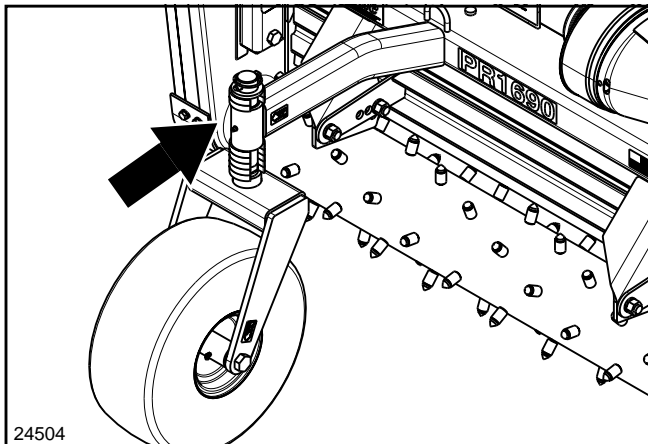
Quantity: Add grease until grease begin to emerge from either top or bottom bushings



	 25 Hours
--	--



Gauge Wheel Spindle

Grease gauge wheel spindle every 25 hours
One grease zerk for each gauge wheel

Type of Lubrication: Multi-Purpose Grease

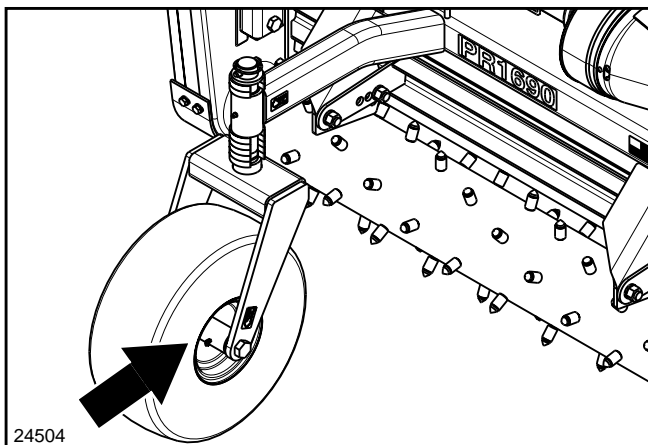
Quantity: Add grease until grease begin to emerge from either top or bottom bushings.



	 25 Hours
---	---

Gauge Wheel Axle

Grease gauge wheel axle every 25 hours
One grease zerk for each gauge wheel

1Type of Lubrication: Multi-Purpose Grease

Quantity: Add grease until grease begins to emerge from either side of the axle hub.

Section 4: Maintenance & Lubrication

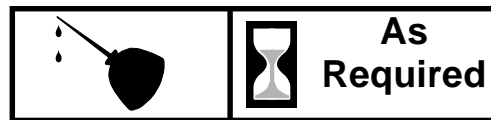
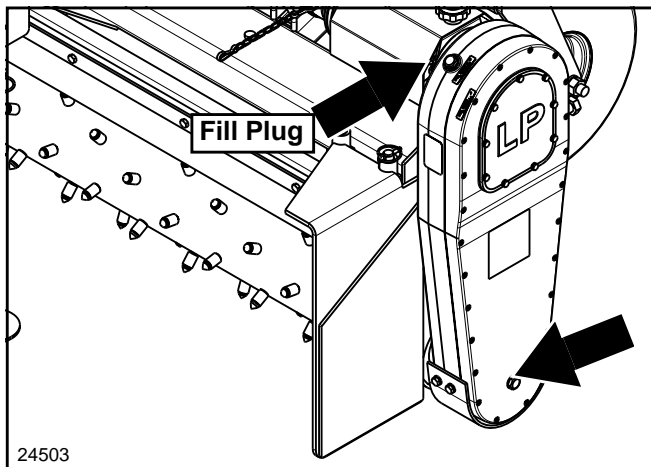

Drive Chain

Fill through top Fill plug and check quantity at lower plug.

Type of Lubrication: Shell Alvania EP00 gear lube
Land Pride #821-045C (32oz. bottle)

Quantity: 2 1/2 pints (Gear Lube will run out of lower plug when full.)

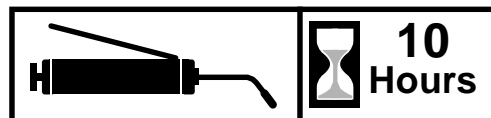

Non-Drive Bearing

Grease gauge non-drive bearing every 10 hours
One grease zerk inside skid shoe

Type of Lubrication: Multi-Purpose Grease (Remove Skid Shoe to grease)

Quantity: Add grease until grease begins to emerge from either side of the axle.

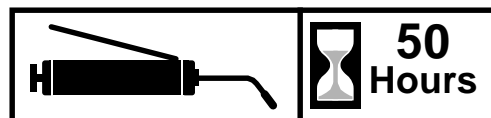
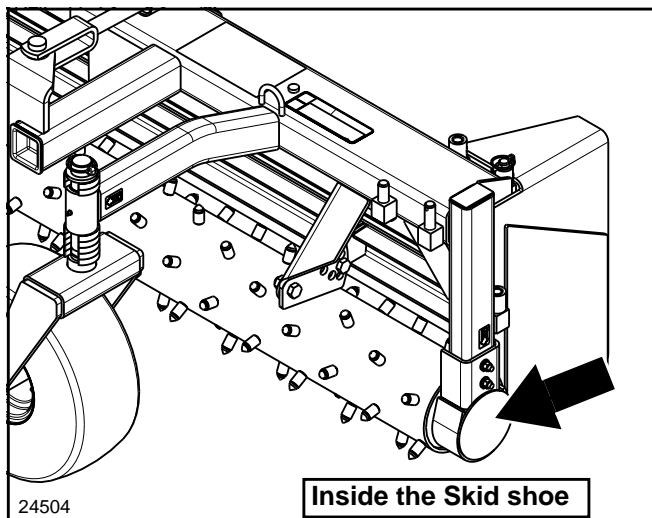

Gearbox

Check Gear box oil level every 50 hours

Type of Lubrication: 1 1/2 pints of SAE 90W gear lube

Quantity: With gearbox level check oil in box by removing plug from backside. If oil level is low remove top plug and fill with lube until fluid flows from back port. Do not overfill.

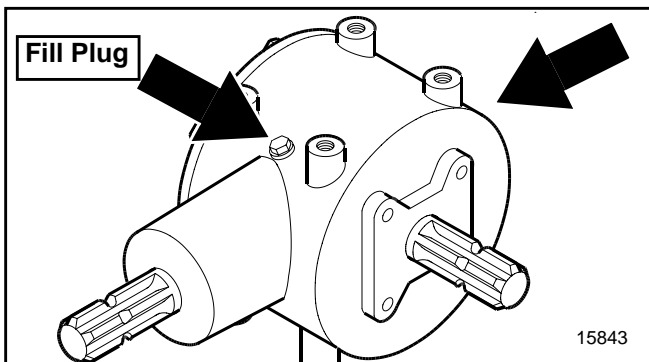



Section 5: Specifications & Capacities

PR16 Series Powered Rake

	PR1660	PR1672	PR1690
Working Width	60"	72"	90"
Weight	980 lbs.	1000 lbs.	1120
Tractor Horsepower Range	25-40	25-40	35-75
Hitch	Cat. 1		Cat. I and II
Quick-Hitch	Fits Land Pride Quick-Hitch		
Gearbox	540 RPM, Ball Bearings, Cast Iron Housing, Drain Plug		
Primary Driveline	Cat. 3 Heavy-Duty		
Secondary Driveline	Cat. 3 with Slip-Clutch		
Material Control Deflector	1/2" X 5" Urethane		
Roller	9 3/8" Dia. with 3/4"X1 1/2" Carbide Tipped Studs or 8 3/16" Dia. with 3/4" Spiral Bars, 180-260 RPM		
Bearings at Roller Ends	Ball Bearing		
Drive Chain	#50 Double Roller Chain		
Angle Adjustment	15 degrees left or right		
Angle Cylinder	2" X 8"		
End Plates	Standard, Removable with Storage Rack		
Gauge Wheels	13" X 6.5"	16.5" X 6.5"	16.5" X 6.5"
	Air Tires with Sealant and 3/4" Roller Bearings and Spacer Height Adjustment		
Skid Shoes	Replaceable		
Gearbox Lubrication	SAE 90 Weight Gear Lube - 1 1/2 pints empty (Add gear lube until it escapes from lower plug hole.)		
Chain Case Lubrication	Shell Alvania EP00 - 2 1/2 pints empty (Land Pride No. 821-045C) (Add gear lube until it escapes from lower plug hole.)		

PR16 Series Powered Rake

Features	Benefits
Working widths	60", 72" & 90"
Tractor Horsepower Range	PR1660 = 25 - 40 HP PR1672 = 25 - 40 HP PR1690 = 35 - 75 HP
Cat. 3 drivelines with slip-clutch on second driveline	Slip-clutch offers protection to the gearbox and entire power train when a tough obstruction is encountered with the roller.
3/4" x 1 1/2" Carbide Tipped Studs	Carbide tipped studs are very tough, used in the mining industry, this offers a long life to the studs. Studs can be replaced one at a time.
15 Degrees left or right angling	By angling either direction, the user has many options on what direction to work his area.
Gauge wheels with sealant	Tall and wide tires keep turning in fluffy soil. Sealant helps seal against punctures.
End plates with storage	End plates can be used to hold dirt to aid in filling low spots. Easily store the end plates on the Powered Rake so that they are always with the Rake when needed.
Material control deflector	Material control deflector is used to determine what size of material to let pass through the roller and what size to move out.
Replaceable skid shoes	Skid shoes protect larger and vital parts of the unit. As they wear due to soil contact, they can easily be replaced.
#50 Double continuous roller chain	Double roller chain can take the fluctuation loads from the roller due to varying ground conditions.
Cast Iron chain guard housing	Strong enough to protect chain in harsh conditions.
Drive chain enclosed in oil bath with drain plug	Oil keeps the chain and sprockets lubricated to keep abrasion to a minimum. Easy to maintain and change oil level.
5 Year gearbox warranty	Shows our confidence in the gearbox integrity.
Quick Hitch	Can be used with Land Pride Quick-Hitch. (May need extra driveline.)



Section 7: Troubleshooting

Problem	Solution
Machine makes intermittent clicking noise	Check for damaged gear and replace if necessary.
	Check for worn drive chain and replace if necessary.
Roller will not turn	Obstruction between roller and material control deflector.
	Chain is off.
	Burnt or mis-adjusted slip-clutch on driveline shaft.
	Broken drive spindle.
Operating depth insufficient	Raise gauge wheels.
	Increase tractor RPM.
	Clean roller.
Roller gouging on the end	The gauge wheel on chain case side should be approximately 1" lower than the non-drive side gauge wheel for consistent leveling.
	Set gauge wheel depth.
	Correct air pressure in gauge wheels.
	Level 3-point arms on tractor.
Too much dirt going into the windrow or dirt going over the top of the material control deflector	Reduce ground speed.
	Raise material control deflector.
	Lower gauge wheels.
Too many rocks passing between material control deflector and the roller	Lower material control deflector.
Roller balling up with soil	Wait until soil dries.
Powered Rake bumping on ground	Clean roller.
	Increase roller speed if roller is turning slow. Decrease roller speed if roller is turning fast.



Torque Values Chart for Common Bolt Sizes													
Bolt Size (Inches)	Bolt Head Identification						Bolt Size (Metric)	Bolt Head Identification					
	Grade 2		Grade 5		Grade 8			Class 5.8		Class 8.8		Class 10.9	
in-tpi ¹	N · ft-lb ³	N · m	ft-lb	N · m	ft-lb	mm x	N · m	ft-lb	N · m	ft-lb	N · m	ft-lb	
1/4" - 20	7.4	5.6	11	8	16	12	M 5 X 0.8	4	3	6	5	9	7
1/4" - 28	8.5	6	13	10	18	14	M 6 X 1	7	5	11	8	15	11
5/16" - 18	15	11	24	17	33	25	M 8 X 1.25	17	12	26	19	36	27
5/16" - 24	17	13	26	19	37	27	M 8 X 1	18	13	28	21	39	29
3/8" - 16	27	20	42	31	59	44	M10 X 1.5	33	24	52	39	72	53
3/8" - 24	31	22	47	35	67	49	M10 X 0.75	39	29	61	45	85	62
7/16" - 14	43	32	67	49	95	70	M12 X 1.75	58	42	91	67	125	93
7/16" - 20	49	36	75	55	105	78	M12 X 1.5	60	44	95	70	130	97
1/2" - 13	66	49	105	76	145	105	M12 X 1	90	66	105	77	145	105
1/2" - 20	75	55	115	85	165	120	M14 X 2	92	68	145	105	200	150
9/16" - 12	95	70	150	110	210	155	M14 X 1.5	99	73	155	115	215	160
9/16" - 18	105	79	165	120	235	170	M16 X 2	145	105	225	165	315	230
5/8" - 11	130	97	205	150	285	210	M16 X 1.5	155	115	240	180	335	245
5/8" - 18	150	110	230	170	325	240	M18 X 2.5	195	145	310	230	405	300
3/4" - 10	235	170	360	265	510	375	M18 X 1.5	220	165	350	260	485	355
3/4" - 16	260	190	405	295	570	420	M20 X 2.5	280	205	440	325	610	450
7/8" - 9	225	165	585	430	820	605	M20 X 1.5	310	230	650	480	900	665
7/8" - 14	250	185	640	475	905	670	M24 X 3	480	355	760	560	1050	780
1" - 8	340	250	875	645	1230	910	M24 X 2	525	390	830	610	1150	845
1" - 12	370	275	955	705	1350	995	M30 X 3.5	960	705	1510	1120	2100	1550
1-1/8" - 7	480	355	1080	795	1750	1290	M30 X 2	1060	785	1680	1240	2320	1710
1 1/8" - 12	540	395	1210	890	1960	1440	M36 X 3.5	1730	1270	2650	1950	3660	2700
1 1/4" - 7	680	500	1520	1120	2460	1820	M36 X 2	1880	1380	2960	2190	4100	3220
1 1/4" - 12	750	555	1680	1240	2730	2010							
1 3/8" - 6	890	655	1990	1470	3230	2380							
1 3/8" - 12	1010	745	2270	1670	3680	2710							
1 1/2" - 6	1180	870	2640	1950	4290	3160							
1 1/2" - 12	1330	980	2970	2190	4820	3560							

¹ in-tpi = nominal thread dia. in inches-threads per inch
² N · m = newton-meters
³ ft-lb= foot pounds
⁴ mm x pitch = nominal thread dia. in millimeters x thread pitch

Torque tolerance + 0%, -15% of torquing values. Unless otherwise specified use torque values listed above.

Tire Inflation Chart	
Tire Size	Inflation PSI
16.5 x 6.5 2- Ply	45

Warranty

Land Pride warrants to the original purchaser that this Land Pride product will be free from defects in material and workmanship beginning on the date of purchase by the end user according to the following schedule when used as intended and under normal service and conditions for personal use.

Overall Unit and Driveline: One year Parts and Labor

Primary Driveline: One year Parts and Labor.

Slip-clutch Friction plates are considered wear items.

Gearbox: 5 years Parts and Labor

Roller: Considered a wear item

Hydraulic Cylinder: 1 year parts and labor.

Hoses and seals are considered wear items.

This Warranty is limited to the replacement of any defective part by Land Pride and the installation by the dealer of any such replacement part, and does not cover common wear items such as blades, belts, tines, etc. Land Pride reserves the right to inspect any equipment or parts which are claimed to have been defective in material or workmanship.

This Warranty does not apply to any part or product which in Land Pride's judgment shall have been misused or damaged by accident or lack of normal maintenance or care, or which has been repaired or altered in a way which adversely affects its performance or reliability, or which has been used for a purpose for which the product is not designed. Misuse also specifically includes failure to properly maintain oil levels, grease points and driveline shafts.

Claims under this Warranty must be made to the dealer which originally sold the product and all warranty adjustments must be made through such dealer. Land Pride reserves the right to make changes in materials or design of the product at any time without notice.

This Warranty shall not be interpreted to render Land Pride liable for damages of any kind, direct, consequential, or contingent to property. Furthermore, Land Pride shall not be liable for damages resulting from any cause beyond its reasonable control. This Warranty does not extend to loss of crops, any expense or loss for labor, supplies, rental machinery or for any other reason.

No other warranty of any kind whatsoever, express or implied, is made with respect to this sale; and all implied warranties of merchantability and fitness for a particular purpose which exceed the obligations set forth in this written warranty are hereby disclaimed and excluded from this sale.

This Warranty is not valid unless registered with Land Pride within 30 days from the date of purchase by the end user.



Corporate Office: P.O. Box 5060
Salina, Kansas 67402-5060 USA
www.landpride.com

Free Manuals Download Website

<http://myh66.com>

<http://usermanuals.us>

<http://www.somanuals.com>

<http://www.4manuals.cc>

<http://www.manual-lib.com>

<http://www.404manual.com>

<http://www.luxmanual.com>

<http://aubethermostatmanual.com>

Golf course search by state

<http://golfingnear.com>

Email search by domain

<http://emailbydomain.com>

Auto manuals search

<http://auto.somanuals.com>

TV manuals search

<http://tv.somanuals.com>