

Lanier R/C
1/3rd Scale
LASER 200
Almost Ready to Fly



WARNING! THIS IS NOT A TOY!
THIS IS NOT A BEGINNER'S AIRPLANE

This R/C kit and the model you will build from it is not a toy! It is capable of serious bodily harm and property damage. It is your responsibility, and yours alone - to build this kit correctly, properly install all R/C components and flying gear (engine, tank, radio, pushrods, etc. and to test the model and fly it only with experienced, competent help, using common sense and in accordance with all safety standards as set forth in the Academy of Model Aeronautics Safety Code. It is suggested that you join the A.M.A. and become properly insured before attempting to fly this model. If you are just starting R/C modeling, consult your local hobby dealer or write to the Academy of Model Aeronautics to find an experienced instructor in your area. Write to: Academy of Model Aeronautics, 5151 Memorial Drive, Indianapolis, IN 47302

LIMITED WARRANTY

Lanier R/C is proud of the care and attention that goes into the manufacture of parts for its model kits. The company warrants that for a period of 30 days, it will replace, at the buyer's request, any part or material shown to the company's satisfaction to have been defective in workmanship or material at the time of purchase.

No other warranty of any kind, expressed or implied, is made with respect to the merchandise sold by the company. The buyer acknowledges and understands that he is purchasing only a component kit from which the buyer will himself construct a finished flying model airplane. The company is neither the manufacturer of such a flying model airplane, nor a seller of it. The buyer hereby assumes the risk and all liability for personal or property damage or injury arising out of the buyer's use of the components or the finished flying model airplane, whenever any such damage or injury shall occur.

Any action brought forth against the company, based on the breach of the contract of sale to the buyer, or on any alleged warranty thereunder, must be brought within one year of the date of such sale, or thereafter be barred. This one-year limitation is imposed by agreement of the parties as permitted by the laws of the state of Georgia.

© 2002 Lanier R/C

BUILDING INSTRUCTIONS

Before starting to build this kit, we urge you to read through these instructions thoroughly. They contain some important building sequences as well as instructions and warnings concerning the assembly and use of the model.

BUILDING SUPPLIES NEEDED

- Hobby knife w /#11 blade
- Medium Zap CA
- 30 Minute Z-poxy
- Wire cutters
- Pliers
- Drill w th bits: 1/32", 1/16", 1/8", 5/32", 1/4"

See the list at the end of the instruction book for a list of additional R/C equipment you will need to complete the 1/3rd Laser.

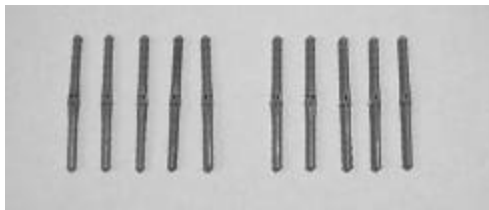

1. Locate (10) hinge points.



2. Use the picture as a guide to find the (5) holes in each aileron and each side of the wing. Test fit a hinge in each hole.



3. Put a small drop of oil on each hinge, then use 30 minute epoxy on each hinge and hole. Press the ailerons in place, leaving a 1/32" gap at the hinge line, then wipe off any excess epoxy off with alcohol and a paper towel.
4. At the two locations on the wing, remove the covering from the hole to install your aileron servo.

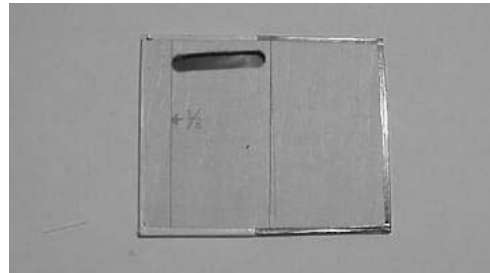

5. Mark the location of the aileron servo plate rails on the inside of the plywood servo plate (approx. 3/8"). Remove the covering from the hole for the servo arm.

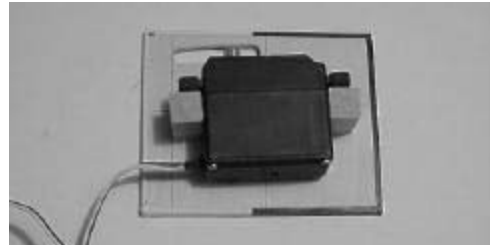

6. Position your aileron servos and the hardware blocks on the plates and mark the position.

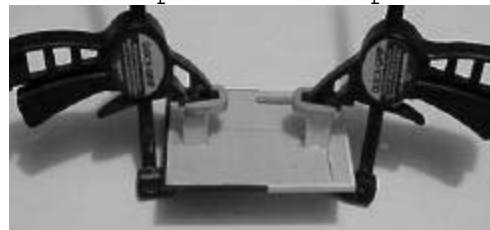

7. Glue the blocks in place on the plates with 30 minute epoxy.

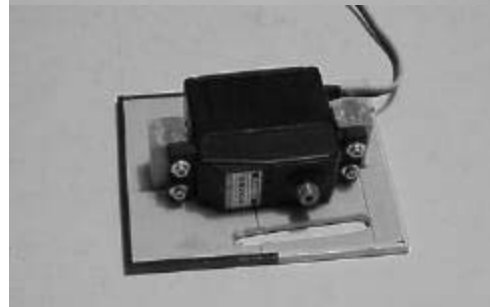
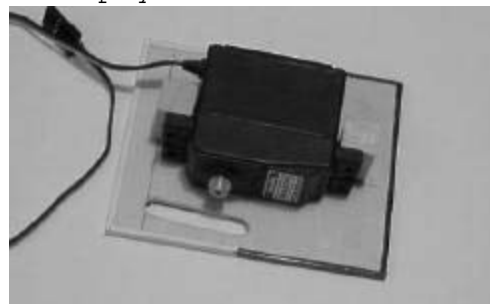

8. When cured, replace the servo and drill 1/32" pilot holes for the servo screws included with the

radio. Center the servo by hooking it up to the proper channel of your radio and centering the trim tabs.

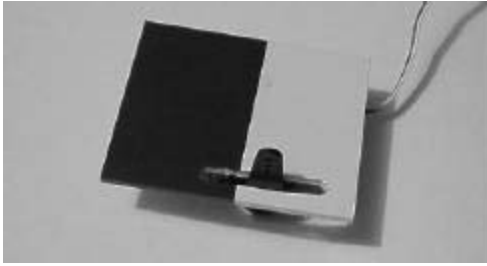

9. Install your servo horn so that it is protruding the hole of the plate and install the servo horn screw.



10. Use a piece of music wire or wooden dowel to help feed the servo wires through the wing. You will need to add extensions to the aileron servo wires to reach into the fuselage.

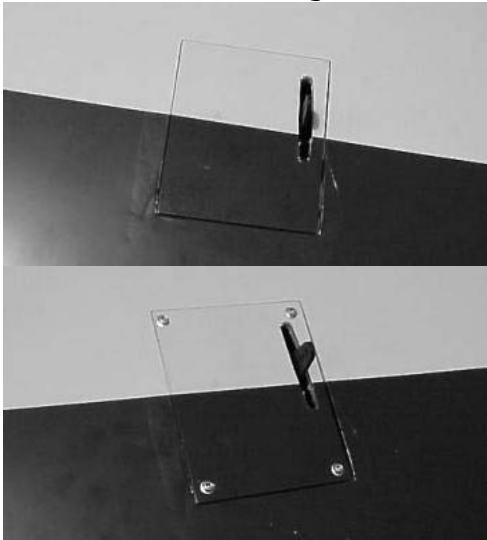

11. Fasten the servo plate to the hardware plate rails in the wing with (4) #4 x 1/2" screws (dubro #382)

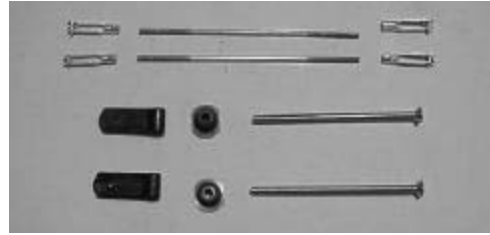

12. Locate the Sullivan aileron hardware, (2) 2 7/8" long 4-40 rods, (4) clevis, (2) couplers, (2) machined nuts, and (2) 8-32 long" screws. Trim and thread the rods as needed. Install a clevis on the end of each rod.



13. Install a (4) arm servo wheel on the servo temporarily, making sure it is parallel to the wing. Locate the hard points in the ailerons, and pierce the covering with a sharp hobby blade. Install the (2) aileron control horn screws from the top of the wing, down through the aileron. Secure the bolt with the machined nut, and thread lock. Install the (2) couplers on the control horn bolts until the threads just show from the tops. Hook the links to the aileron couplers and lay the rods across the servo arm.
14. Install the two clevis on the ends of the 4-40 rod. Align the aileron on the wing and hold in position with a small piece of tape. Adjust the clevis to the proper length, then install on the servo and coupler. Use red thread lock when adjusted, then install the clevis keeper.



15. Using a sharp hobby blade, cut the covering away from the wing tube and locating pin holes. You may want to seal the covering down with CA or a sealing iron.

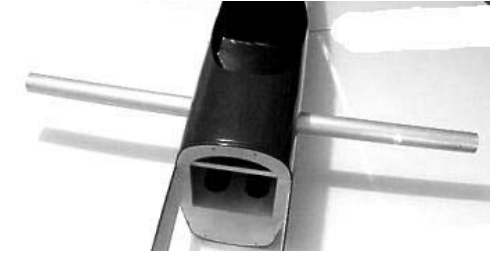

16. Test fit the wing tube through the fuselage. Use a ruler to help center the tube in the fuse, then mark the alignment with a permanent marker.

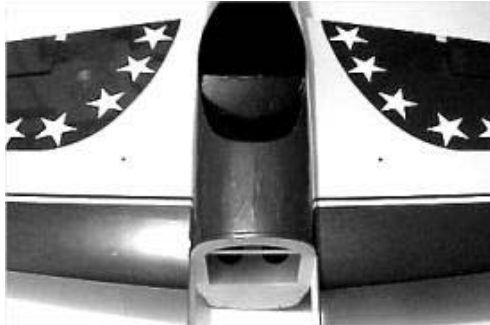

17. Temporarily mount the wing on the wing tube, sliding the dowels in the locator holes. Be careful to keep the tube centered in the fuse.



18. Locate the (2) 6-32 x 1" bolts. With the wings tight against the fuse, drill (2) 0.1" holes through the aluminum tube.

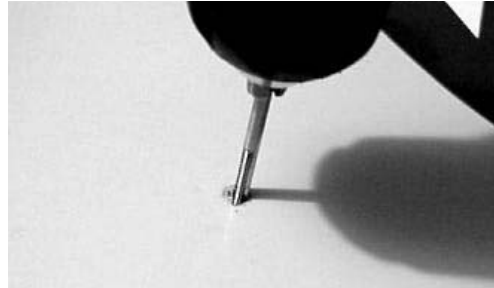

19. Use a 6-32 tap to thread the holes in the tube.



20. Counter sink the hard points 1/8" deep with a 1/4" drill bit. Work carefully to keep the wood from splitting.



21. Test fit the bolts in the holes. Put thread lock on one bolt and cover the bolt hole with 3M vinyl tape. Leave this bolt in place permanently.

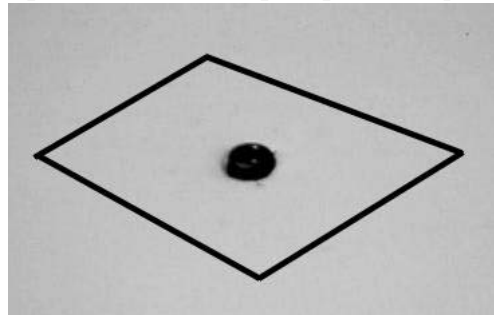

22. When ready for flying, put 3M clear vinyl tape over the other bolt.

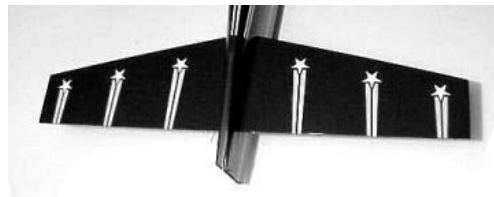

23. Temporarily install the horizontal stabilizer. You may need to sand the opening slightly to be able to slide it in, but be careful to keep the stabilizer aligned parallel to the wing.



24. Align the stabilizer by measuring from each side to the center and equalizing the distance, then measure from the stabilizer tips to the trailing edge of the wing and set each side equal.



25. Mark the joint with a felt marker on the top and bottom. Slide the stabilizer back out, then remove the covering from inside the marks, 1/8" inside the lines you marked. Use a sharp hobby blade to cut the covering. Be very careful to not cut the balsa under the covering. Slide the stabilizer back in the fuselage just until the exposed balsa is at the tail opening. Apply a thin coat of 30 minute epoxy to the exposed balsa, then slide the stabilizer back in the tail. Re-align the stabilizer with the marks you made earlier and double check your measurements to the wing from your building surface. Wipe off any excess glue with alcohol and a paper towel. Let set until cured.



26. Temporarily install the vertical stabilizer in the horizontal slot at the rear of the fuse. Mark the joint with a felt tip marker. Make sure the stabilizer is aligned at 90° to the horizontal stabilizer, then remove the stabilizer and remove the covering as was done with the horizontal stabilizer.

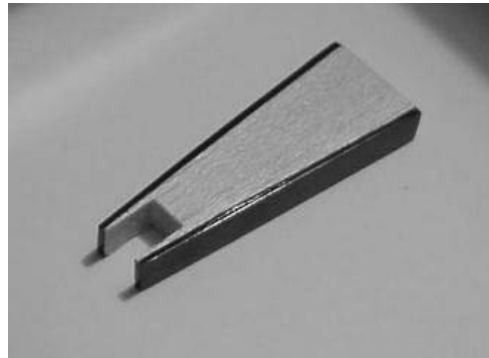

27. Test fit the small horizontal stab spacer block in the space behind the stab.



28. Spread some epoxy on the spacer block and insert in the rear of the fuse. Proceed to the next step before the epoxy cures.



29. Put some 30 minute epoxy in the slot and on the exposed balsa on the stabilizer, then slide together. Check that it is at 90° to the horizontal stabilizer. Wipe off any excess glue with alcohol.

and a paper towel. Let set until cured.

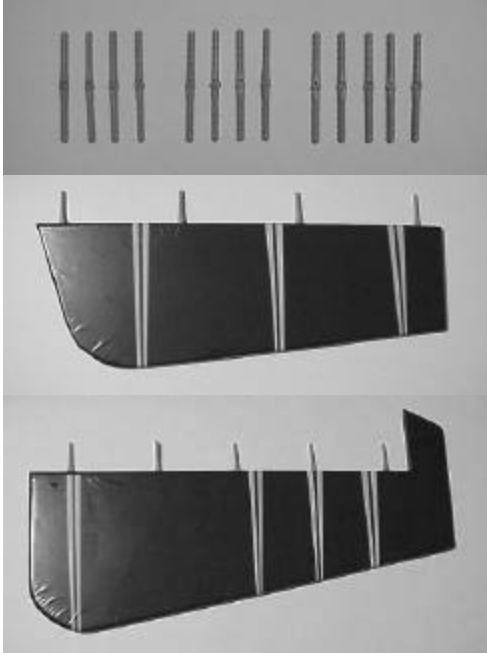

30. Locate the (4) hinge holes in each of the elevator halves, (5) in the rudder, and corresponding holes on the stabilizers, then open the covering with a sharp hobby blade. Test fit one of the (13) hinges in each of the holes. Put a small drop of oil on each of the hinges. Install the hinges in the control surfaces only, using 30 minute epoxy, then align them by pressing onto a flat surface. Clean up any excess glue with alcohol. Do not install the surfaces on the stabilizers until the epoxy has cured.

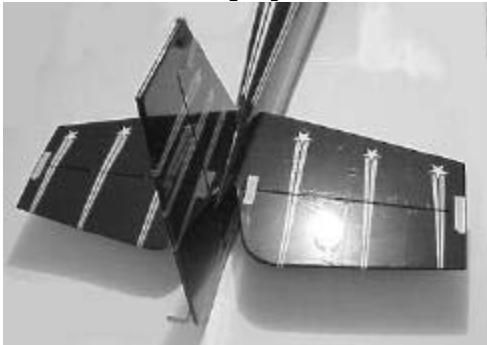

31. Install the surfaces on the rear of the fuselage using 30 minute epoxy. Press in place and leave a 1/32" gap. Wipe off any excess glue with alcohol and a paper towel. Let set until cured.

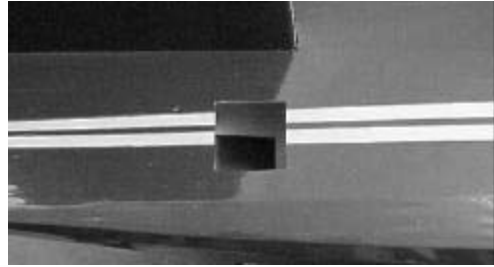

32. Locate the servo openings on the sides of the fuselage and cut the covering away with a sharp knife.

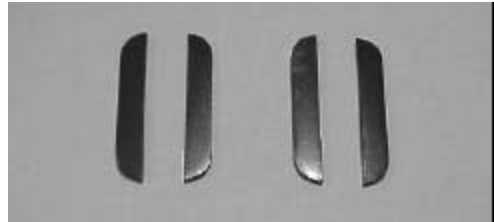

33. Locate the tail servo ply plates and position them on both sides of the servo openings.

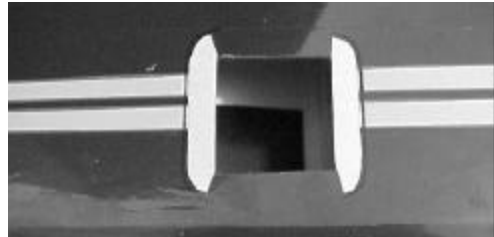

34. Mark the ply plate positions with a marker, then remove the covering with a sharp knife.



35. Glue the ply plates in place with 30 minute epoxy, and clamp in place until cured.



36. Locate your tail servos and install 24" extension wires on the leads (secure them together with tape). Install the servos with the hardware included, then center them with your radio.

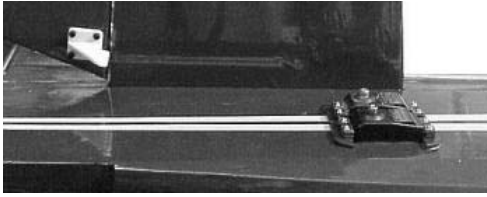

37. Use a straight edge to align the elevator and rudder control horns location.



38. Install the horns on the elevator halves with (4) 4-40 screws in each horn going through to the backing plate.

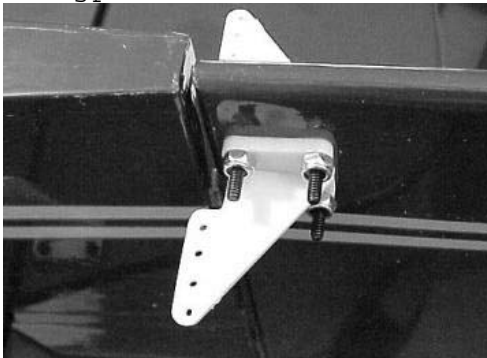

39. Install the rudder horns by securing them with (4) 4-40 screws and (4) nylon lock nuts.



40. Install your servo arms (D ubro heavy duty, not included) on the servos.
 41. Trial fit the 4-40 rods and clevis on the servos and horns, the 5 1/2" rods are for the elevator halves, the 10" rods are for the rudder. Two solder clevis are used on the rudder rods. Trim the rods to length as needed. When the lengths are determined and all surfaces are centered, lock the clevis on the rod with locktite. (You can also solder one clevis in position if you want to be very secure) Also install the clevis keepers on the clevis pins.



42. Locate the tail wheel bracket and parts.

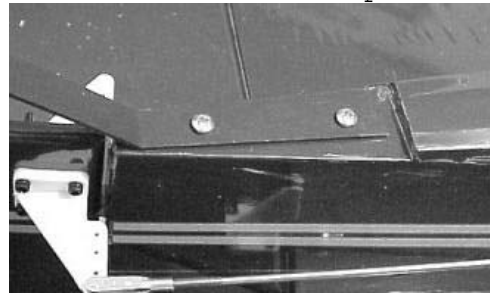

43. Fasten the tail bracket at the rear of the fuselage with two #6 screws. Drill two 3/32" pilot holes before installing. Install so the angle is aligned with the edge of the vertical stabilizer.

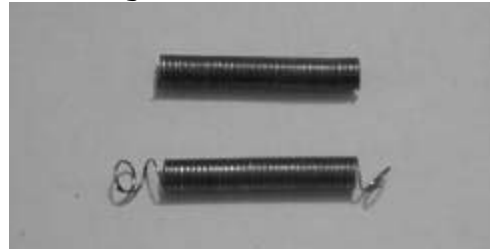

44. Locate the springs for the tail, and prepare the ends by bending a loop on each end.



45. Install a spring on each side of the rudder. Shorten the springs if needed to put even tension on the arms and keep the axle centered.



46. Install the tail wheel on the axle, then secure with the small wheel collar and set screw. Use some thread lock on the screw.

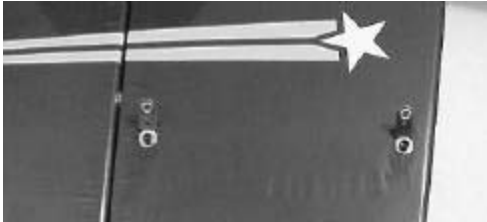

47. Locate the hard points in the tail surfaces for the tail brace wires. Pierce the covering with a sharp blade. Put a slight bend in (12) of the tail wire brackets, then install them in the horizontal and vertical stabilizers as shown, with a bracket on both sides of the surfaces. Use a 4-40 screw and lock nut on each bracket.

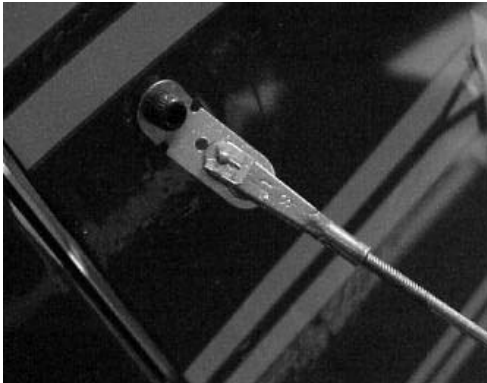

48. Install a 2-56 clevis on the ends of the (8) 2-56 threaded rods, then install (4) rods in the middle hole of the vertical braces.

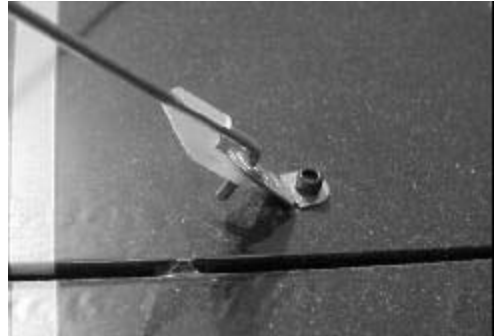

49. Mark the length of the rods about 1/4" past the largest hole in the horizontal braces, then trim. Bend at 90 degrees, then insert in the hole. Secure with an L connector. Adjust at the clevis end, but don't warp the horizontal surface.



50. Install the tail brace bracket using the rear #6 screw. Assemble the other (4) tail brace wires the same as the top, then secure with the L connectors.



51. Make sure each clevis gets a keeper installed.

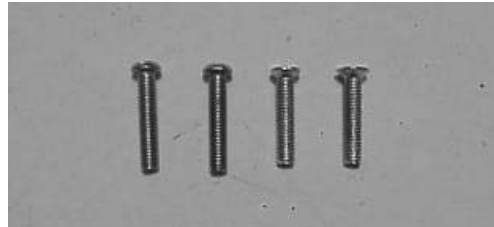

52. Locate the (4) 4 x 20mm screws for installation of the cow l. (2) are round head screws, (2) are flat head screws.



53. Place the fiberglass cowling on the fuselage and fasten with the 4mm screws through the holes. The flat head screws go in the top end of the cowling. Measure from the engine crank hole to the first former surface with a ruler. Write down the length.

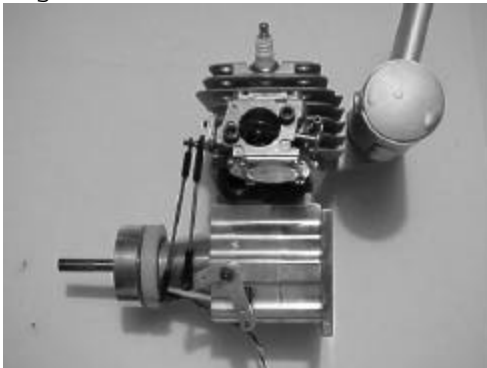

54. Now measure the length of your motor with the motor mount installed, from the front of the prop backing plate to the rear of the mount. Subtract 1/4" from this length (for prop clearance of the cowling).



55. Subtract the motor measurement from the cowling measurement. This will be the distance the firewall needs to be from the first former. Use a ruler and straight edge to make a 90 degree line on the fuselage sides where the firewall should be installed.

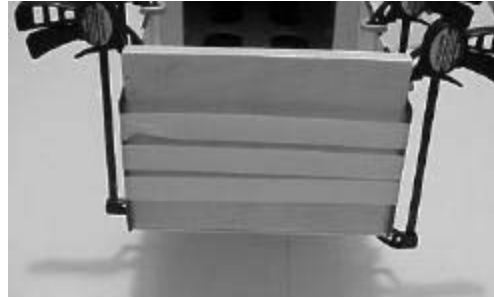

56. Glue the firewall in the fuselage at the marks you just scribed. Use 30 minute epoxy and clamp in place until cured.

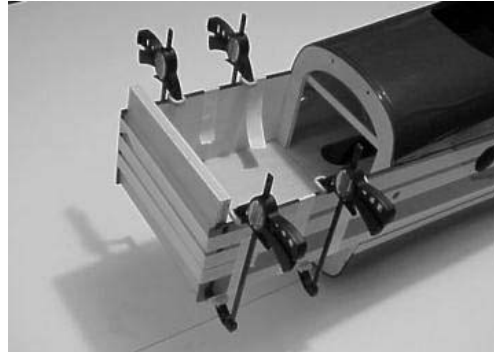

57. Adjust the length of the 1/4 ply lower so the beveled edge is even with the front of the firewall. Remove the covering from the bottom of the firewall formers to allow glue to penetrate, and epoxy the plate in place. Clamp in place until cured.

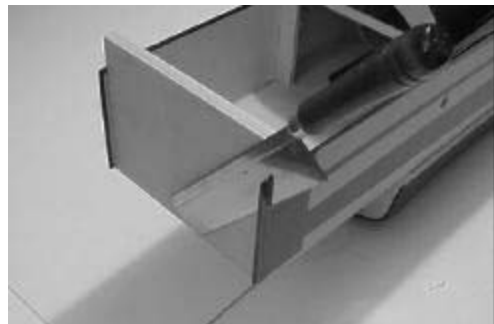

58. When all is cured, cut the fuselage sides flush with the firewall.



59. Adjust the length of the engine box doublers, then glue in place with white glue or epoxy. Clamp until set.

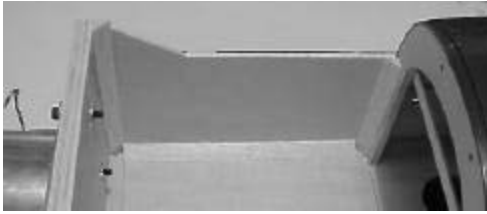

60. Glue the balsa triangle stock in place with CA.



61. Use a ruler to find the vertical center of the firewall and mark a straight line.



62. Make a second mark 1/8" to the right (while looking at the firewall from the front) of the center mark, and make a second mark, then draw a line perpendicular to the first line.



63. Measure down from the top of the firewall 2-1/4" and mark a horizontal line.

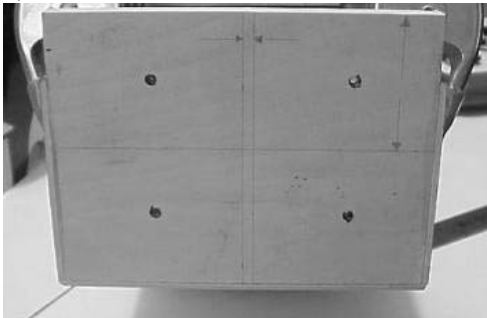

64. Center your engine mount on these lines, then mark the holes on the firewall.



65. Drill the holes for 10-32 bolts and temporarily mount the engine on the firewall with 10-32 x 1" - 1/4 bolts, #10 washers, and blind nuts.

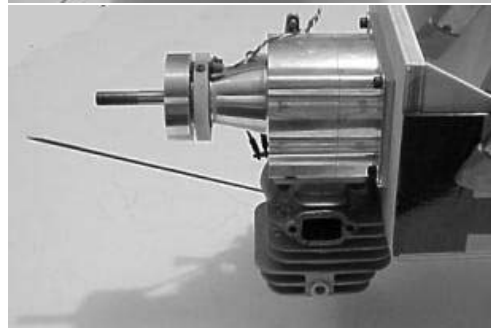

66. Measure the distance from the firewall to the front of the prop back plate and compare to the measurement you calculated earlier. You should have a minimum of 1/8" clearance from the back of the prop to the front of the cowling. If needed, use some scrap plywood spacers to space the engine forward.



67. Place two #8 washers between the firewall and engine mount on both right side engine mounting bolts (facing the firewall) to give the engine right thrust.

68. When the engine is aligned properly, install the 10-32 nylon lock nuts in place inside the

firewall, behind the blind nuts.

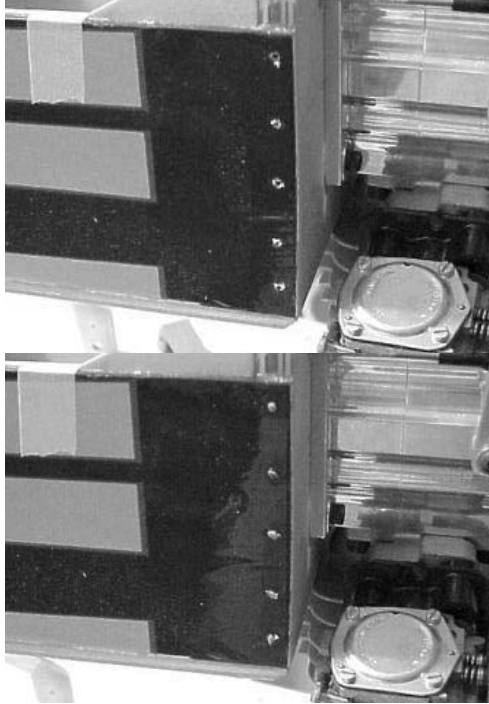

69. Drill (5) 3/32" holes on each side of the firewall, through the fuse sides about 1" deep. Press a wood toothpick into the hole, then cut off flush with some wire snips. Apply several drops of thin CA on each toothpick.

70. Mark on the firewall the location where the throttle control rod should pass through. Drill the marked hole with a 1/8" aircraft drill bit.

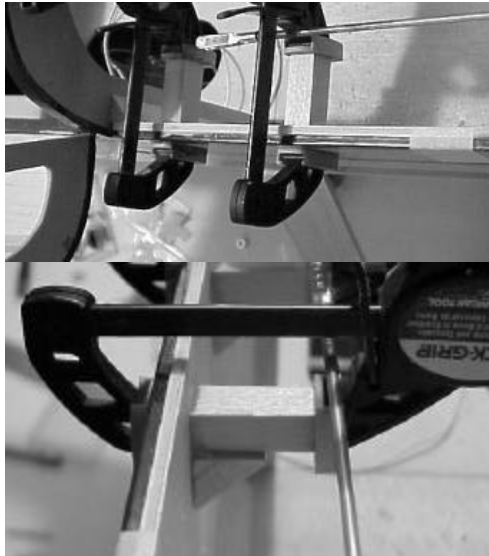

71. Using your servo as a guide, glue the two hardwood servo blocks to the fuse side using 30 minute epoxy. Cut a small piece of balsa triangle stock to fillet the servo rails and fasten with CA.

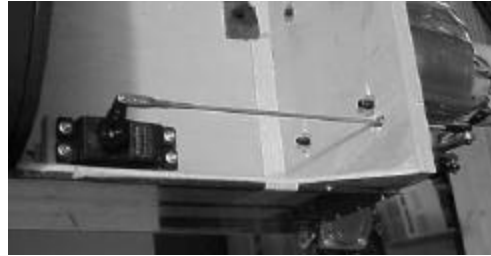

72. Make sure your carburetor and throttle servo are at low position. Reverse your servo if necessary. Thread the 2-56 clevis on the 12" rod, then snap the clevis on the servo arm. Install an EZ connector in the hole on your carburetor approximately the same length of the servo arm. Trim the throttle control rod to approximate length, then insert through the hole in the EZ connector. Tighten the connector enough to test the throw of the servo and adjust as needed to allow for maximum throw, but not bind the servo. When satisfied, trim the control rod to 1/4" past the EZ connector. Install the servo horn screw. When everything is fit, then fuelproof the firewall with polyurethane or thinned epoxy.



73. Test fit the cowlover the engine to see what needs to be relieved. **SHAVE THE TOP CORNERS OF THE FIREWALL TO ELIMINATE RUBBING ON COWL.**



74. Use masking tape to mark the areas that need to be removed for the head of the engine to clear the cowl, then test fit.



75. You will need to relieve more of the cowling, depending on the muffler you decide to use.



76. Install the landing gear on the bottom of the fuselage with the included 4mm screws and washers.

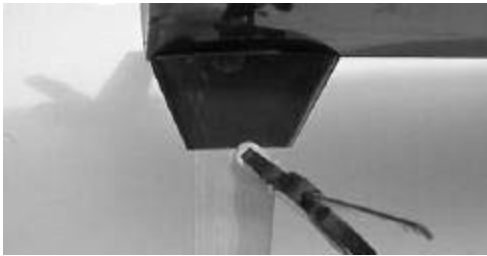

77. Position the gear fairing on the gear, then glue in place with goop. Clamp in place until dry.



78. Locate the position of the axle hole in the wheel pants using the 4" wheel as a guide.



79. Mark the size of the axle hole with the plywood wheel pants plate, then drill with a chamfer grinding bit.



80. Center the wheel pants plate inside the pants, then fasten with 30 minute epoxy.

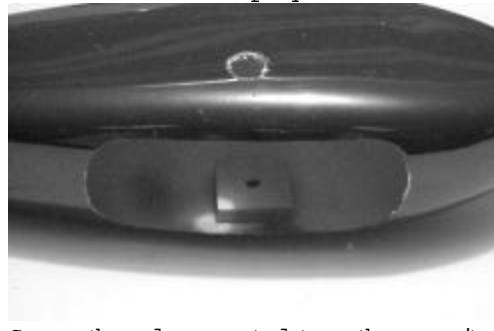

81. Secure the axle support plate on the opposite side, keeping the wheel pants level.



82. Press the 4-40 blind nut into the plate using a small clamp or large pliers.

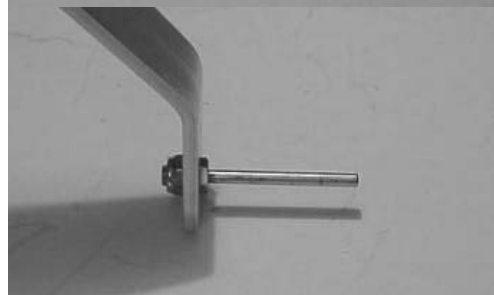
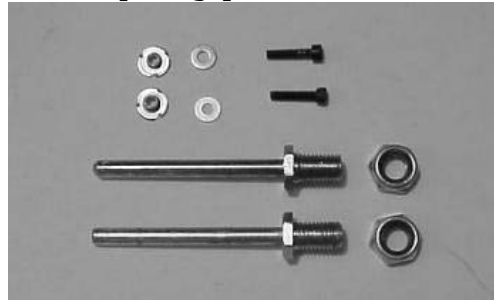

83. Bolt the axle through the landing gear with the axles pointing out. Use thread lock on the bolt.



84. Install the tip of the axle through the pant, then a collar, the 4" wheel and collar, then slide the assembly all the way down the axle. Tighten the wheel collar so that it does not bind the wheel against the wheel.



85. Align each wheel pant to the fuse so that it is level with the thrust line and the rear does not drag the ground, and keep the pair equal. Drill a 1/8" hole in the landing gear to align with the 4-40 blind nut, then install the bolt and washer. USE LOCKTITE ON THIS BOLT!

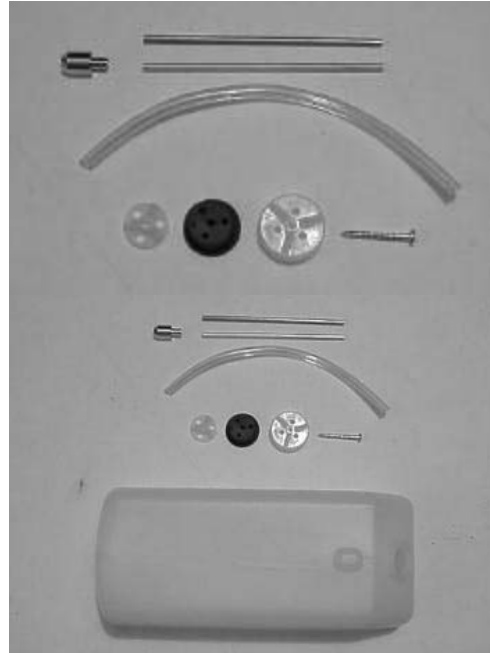

86. Locate the fuel tank and remove all the components for assembly. Check the inside of the tank for any dust or plastic shavings. Blow out if needed. If you are going to use a glow engine, you need to replace the stopper and line with silicone parts.



87. Bend the metal fuel tubes so the vent line fits into the button on the top, and the pickup line is angled toward the bottom just a few degrees, then insert in the fuel stopper. Insert the clunk on the end of the silicone fuel tubing and cut to required length that allow it to move freely at the end of the tank. Insert the nut and bolt in the stopper, then install the stopper in the tank and tighten.



88. Secure the tank in the fuse with cable ties through holes in the fuse floor.
89. Install your fuel line on the end of the tank lines to the muffler pressure and carburetor fittings. Make sure to allow enough extra line to the needle valve line to give access for filling.

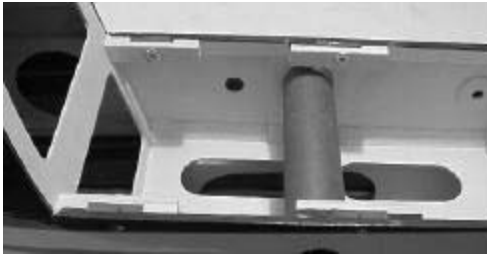

90. Locate the holes for the cockpit screws and remove any covering with a sharp knife.



91. Test fit the cockpit cover and 4 mm flat head screws.



92. Trim the clear plastic canopy 1/4" from the scribed line, then test fit on the fuselage. Trim if needed. Wash the canopy out with cooler water and dish detergent, then dry with a paper towel.



93. Now is the time to install any cockpit details, such as dashboards or pilots (NOT INCLUDED). Secure them firmly in the cockpit with epoxy.



94. Install the canopy on the fuselage with epoxy or "goop". Hold in place with tape until cured.



95. With your engine fully setup, now reinstall the cowling and fasten in place with the cowling screws. Install your prop and 4" spinner. (We recommend Tru Turn spinners.)

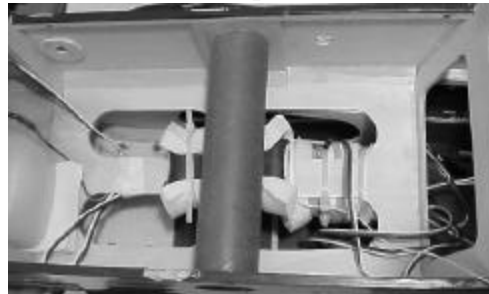

96. Temporarily place your battery and receiver in the fuse, then install the wing. You want the plane to balance on the wing tube center.

97. Move your battery for or aft as needed to achieve a balance. If needed, put the battery in the forward compartment, behind the firewall. When the proper radio gear position is found, wrap the gear with foam and secure in place with Velcro or rubberbands.

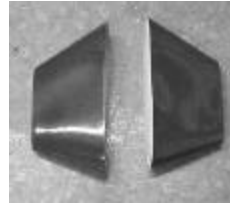

Landing gear cuffs

CONTROL THROWS

Rudder: Low rate - 1-1/2" each way
High rate - all you can get

Elevator: Low rate - 1" each way
High rate - all you can get

Ailerons: Low rate - 1/2" each way
High rate - all you can get



Fiberglass cowling

PRE-FLIGHT NOTES

Before the first flight you should double check a few things to ensure a long life for your new plane.

1. Balance the Laser with the fuel tank empty. Adjust as needed for your particular flying style, but start with the CG forward for the first few flights.
2. Check the control surface throws twice. You may want to change them later, but use the suggestions as a starting point.
3. Break in the engine and test run it. Have it ready before you head to the field.
4. Range check the radio with the engine running to make sure there are no intermittent radio problems.

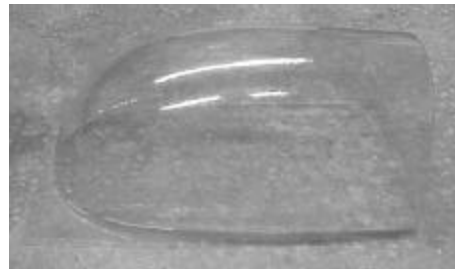

Clear canopy

Double check that all the hardware, nuts, bolts, and hinges are tight.



Fuselage and cockpit hatch

INCLUDED MATERIALS



Horizontal Stab and elevator halves



Wood bag and firewall



Fiberglass wheel pants



Aluminum wing tube

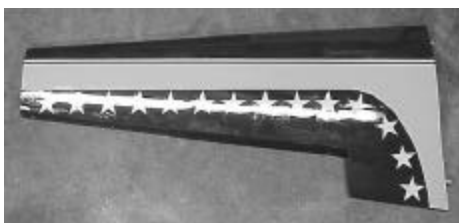

Wing halves



Ailerons



Rudder and Vertical stab

Cowl

- 2 4 x 20mm round head screws
- 2 4 x 20mm flat head screw
- 1 24 oz fuel tank
- 2 Large nylon cable ties

Engine mount

- 4 10-32 x 1-1/2 cap screw
- 8 #10 washer
- 4 10-32 nylon lock nuts
- 1 12" 2-56 rod
- 1 2-56 clevis
- 1 ez connector

Landing gear

- 4 4 x 22mm round head screws
- 4 4mm washer
- 2 4-40 blind nuts
- 2 248 3/16 axle
- 2 4" wheel
- 2 4-40 x 1/2 cap screw
- 2 #4 washer
- 1 Aluminum landing gear

Canopy

- 4 3 x 20mm flathead screw

HARDWARE LIST

Wings

- 2 HD adjustable control horn
- 2 2 & 7/8" 4-40 threaded rods
- 2 6-32 x 1" cap screw
- 10 large hinge points
- 8 #4 x 1/2 sheet metal screw
- 4 4-40 clevis

Tail

- 13 large hinge points
- 4 large t style horns (included)
- 12 4-40 x 3/4 cap screw
- 4 4-40 nylon lock nuts
- 2 10" 4-40 threaded rod
- 2 5 1/2" 4-40 threaded rod
- 6 4-40 clevis
- 2 Solder clevis
- 2 #6 x 3/4" pan head screw
- 1 1-1/4" tail wheel
- 1 Ohio superstar tail wheel bracket
- 2 1/8" wheel collars
- 12 tail brace brackets
- 8 18" 2-56 threaded one end rod
- 8 2-56 clevis
- 8 nylon L connectors
- 1 2"x3/4" aluminum plate with 5 holes,
#6 size in center, 3/32 in 4 corners
- 6 4-40 x 3/4 cap screw
- 6 4-40 nylon lock nuts

ADDITIONAL EQUIPMENT NEEDED TO COMPLETE YOUR 1/3rd LASER ARF

General

- 32 - 422 stroke R/C engine and muffler
- Gas fuel line
- Minimum of 4 chan. radio set req. with (7) servos
- 30 minute Z-poxy
- Medium Zap CA (green)
- Thin Zap CA (pink)
- Zap a dap goop
- (1) radio foam
- Tru Turn 4" spinner
- 6/32 tap
- 3M vinyl tape
- William s Bro. Pilot figure

Free Manuals Download Website

<http://myh66.com>

<http://usermanuals.us>

<http://www.somanuals.com>

<http://www.4manuals.cc>

<http://www.manual-lib.com>

<http://www.404manual.com>

<http://www.luxmanual.com>

<http://aubethermostatmanual.com>

Golf course search by state

<http://golfingnear.com>

Email search by domain

<http://emailbydomain.com>

Auto manuals search

<http://auto.somanuals.com>

TV manuals search

<http://tv.somanuals.com>