

Lanzar[®] Opti

AMERICAN CRAFTED PERFORMANCE



OPTI 1200HC

OPTI 2200HC

OPTI 600 X 2HC

OPTI 400 X 4HC

Owner's Manual **Opti**

Lanzar

Lanzar OPTI OWNER'S MANUAL

Opti

TABLE OF CONTENTS

- 1. Contents**
- 2. Introduction**
- 3. Features**
- 4. Specifications**
- 5. Amplifier installation**
- 6-9. Features and controls**
- 10-17. System wiring**
- 18-19. Troubleshooting**

Lanzar OPTI OWNER'S MANUAL - 1

INTRODUCTION

Thank you for purchasing the Lanza OPTI High Current Power Amplifier. Rest assured you have purchased a quality product designed and engineered to give you many years of compromise musical service. The OPTI High Current Power Amplifier has been designed using the latest in electronic technology available today.

This mono sub-woofer amplifier is the result of advanced high speed switching technology that overcomes the less-efficient class AB design. The OPTI High Current Power Amplifier reflects your true appreciation for powerful bass reproduction in the mobile environment.

This amplifier is designed for low-frequency information only and it is not capable of reproducing any mid/high-frequency information.

This is due to the noise introduced into the signal by the switching speed of the power supply, which must be filtered out of the audio signal.

The power supply incorporated into OPTI amplifier is a DC to DC switching power supply designed to have adequate headroom for even the most demanding peak and dynamic range found on CD's and recording.

Lanza

Opti FEATURES

- **HIGH CURRENT DESIGN**

- **POWER SUPPLIES**

Stiffly regulated PWM power supplies.

MOSFET switches maintain rated power over a wide range of battery voltages.

- **LOW PASS FILTER**

Adjustable from 50Hz to 120Hz with a slope of 24dB per octave.

This allows for the adjustment of the upper point of the frequency bandwidth and the respective subwoofer. (OPTI1200HC / 1200HC: 50Hz~150Hz)

- **VARIABLE SUBSONIC FILTER**

Adjustable from 20Hz to 50Hz with a slope of 24dB per octave.

This allows for the attenuation of frequencies that are mostly inaudible and cause unnecessary strain on the amplifier.

- **PROTECTION CIRCUITRY**

Protection against thermal, Overload and short circuit conditions.

- **REMOTE DASH-MOUNT GAIN CONTROL**

This amplifier come complete with a compact remote **GAIN CONTROLLER** which can be conveniently mounted on or under the dashboard of your car.

- **COOLING FAN(S)**

SPECIFICATIONS

MODEL	OPTI 1200HC	OPTI 2200HC	OPTI 600 X 2HC	OPTI 400 X 4HC
RMS Power, INTO 4 Ohms	350W x 1	450W x 1	300W x 2	100W x 4
RMS Power, INTO 2 Ohms	600W x 1	800W x 1	500W x 2	180W x 4
RMS Power, INTO 1.3 Ohms	900W x 1	1100W x 1	700W x 2	230W x 4
MAX Power, INTO 1.3 Ohms	1200W x 1	2200W x 1	1200W x 2	390W x 4
BRIDGE MAX Power, INTO 2 Ohms	N/A	N/A	1400W x 1	450W x 2
THD at 1 Watt, 4 Ohm	0.04%	0.04%	0.04%	0.04%
Signal-to-Noise Ratio	>105dB	>105dB	>105dB	>105dB
Frequency Response, at 1 Watt, 4 Ohm	10Hz ~ 35KHz, 1dB	10Hz ~ 35KHz, 1dB	10Hz ~ 35KHz, 1dB	10Hz ~ 35KHz, 1dB
Crossover (Low Pass Filter)	50Hz~150Hz	50Hz~150Hz	50Hz~120Hz	50Hz~120Hz
Crossover (High Pass Filter)	N/A	N/A	50Hz~750Hz	50Hz~750Hz
Bass Boost (Gain)	0~+18dB	0~+18dB	0~+18dB	0~+18dB
Bass Boost (Freq.)	40Hz~100Hz	40Hz~100Hz	N/A	N/A
Subsonic Filter	20Hz~50Hz	20Hz~50Hz	N/A	N/A
Phase Shift Control	0° to 180°	0° to 180°	N/A	N/A
Input Sensitivity	200mV to 8V	200mV to 8V	200mV to 8V	200mV to 8V
Input Impedance	10K Ohm	10K Ohm	10K Ohm	10K Ohm
Dimensions(Inches)	10.08" x 2.12" x 15.75"	10.08" x 2.12" x 18.31"	10.08" x 2.12" x 23.22"	10.08" x 2.12" x 19.69"
Fuse Rating	30A x 3	40A x 3	40A x 4	40A x 3

AMPLIFIER INSTALLATION

1. Find a suitable location in the vehicle to mount the amplifier.
2. Make sure there is sufficient air flow around the intended mounting location.
3. Bolt the amplifier to the mounting surface.
4. Connect the power ground terminal to the nearest point on the chassis of the car. Keep this ground wire less than one meter (39") in length. Use 4 gauge wire.
5. Connect the remote terminal to the remote output of the head unit using 14 gauge.
6. Connect an empty fuse holder within 300mm (12") of the battery and 4 gauge or larger high quality cable from this fuse to the amplifier location.
7. Make sure there is no fuse in this fuse holder. Then make the connection to the "BATT" connection on the amplifier.
8. If multiple amplifiers are being used, use cables (each with its own fuse at the battery) or a #0 or a #2 cable from the fuse holder at the battery to a distribution block at or near the amplifier's location.
9. Connect all line inputs and outputs using high-quality RCA-RCA cables.
10. Insert fuse(s) at the battery fuse holder(s).
11. Recheck all connections before powering up.
12. Set all level controls to their least sensitive positions and set all crossover controls, switches, etc. to the desired frequency or position.
13. Once the system is powered up, set the volume control on the head unit to about the 2 o'clock position, and then set all the amplifiers' level controls for maximum output level.
14. Further fine tuning of the various controls may be necessary to obtain the desired results.

FEATURES AND CONTROLS

OPTI 600X2HC

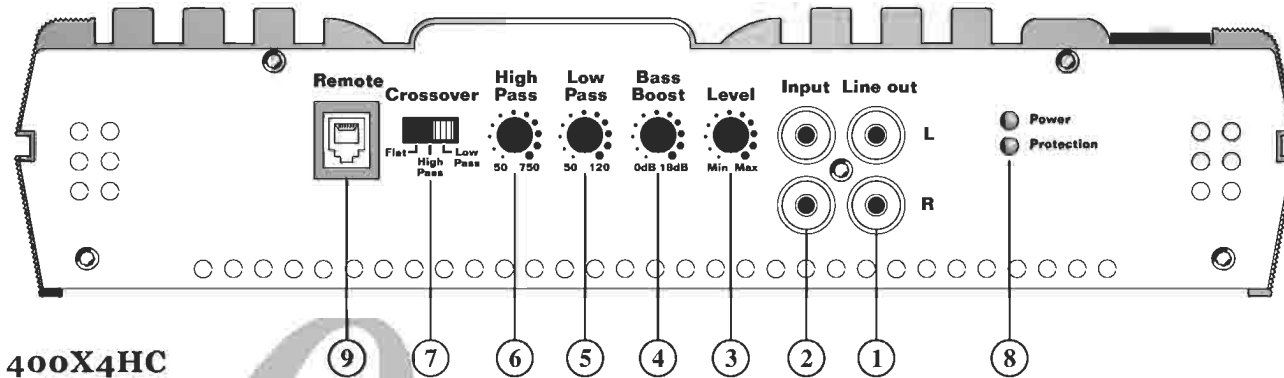

OPTI 400X4HC

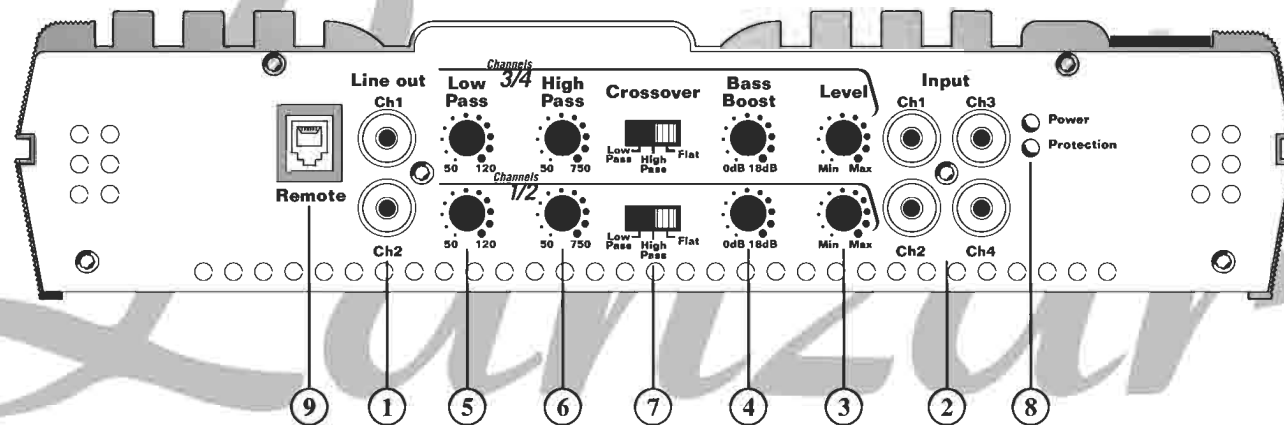

FEATURES AND CONTROLS

OPTI 1200HC / 2200HC

FEATURES AND CONTROLS

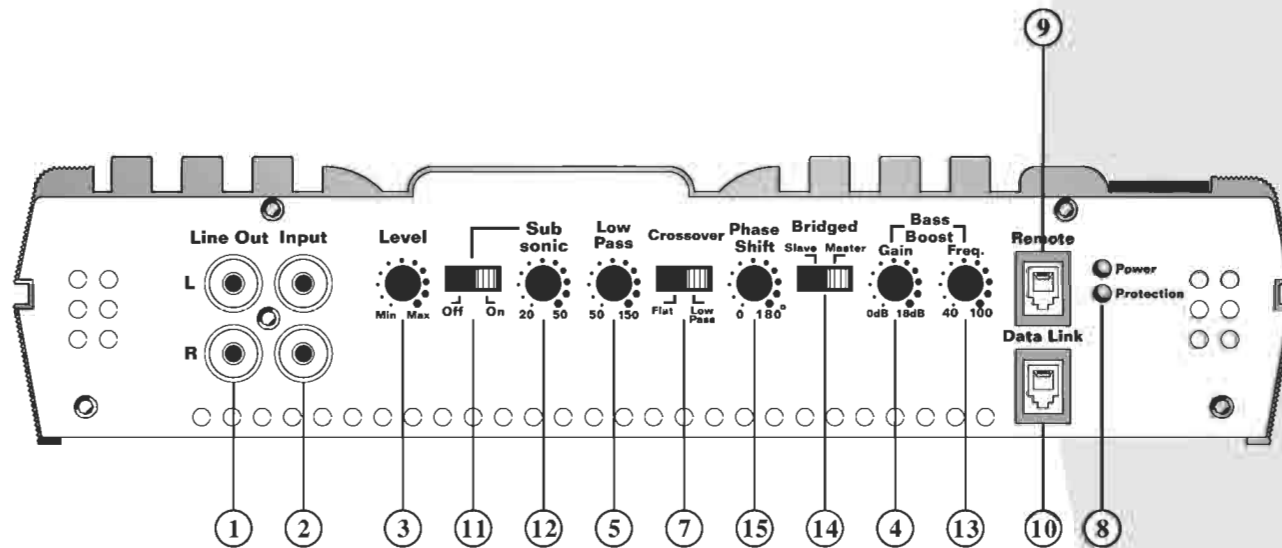

FEATURES AND CONTROLS

1. Line Out RCA Jacks - The LINE OUT allows you to build multiple amplifier systems with out having to use splitter cords to distribute the signal. Now it is simple a matter of bringing one set of RCAs into the first amplifier, then using the line out RCA jacks as the feed to the next amplifier.

2. Input RCA Jacks - These inputs are for signal cables from the source. Always use high quality shielded RCA cables.

3. Level Control- Enables the matching of input levels to the output levels from the head unit(or other signal source).

4.Variable Bass Boost Control- Increases sound level in lower frequency by 18dB.

5.Variable Low Pass Filter- When Crossover Mode Selector is in Low Pass Mode, this control limits the frequencies which will be distributed to the speakers to those below the value to which this is set within the range50~120Hz.(OPTI1200HC/2200HC :50Hz~150Hz)

6.Variable High Pass Filter- When Crossover Mode Selector is in High Pass Mode, this control limits the frequencies which will be distributed to the speakers to those below the value to which this is set within the range50~750Hz.

7.Crossover Mode Selector- Determines the mode of built-in crossover low pass(permits only low frequency signals to pass to speakers), high pass(permits onlt high frequency signals to pass to speakers), or flat.

OPTI **FEATURES AND CONTROLS**

8. Power & Protection Indicators- Provide instant information on status of amplifier, including short-circuit and thermal overload alerts.

9. Bass Boost Remote Control Input

10. Data Link

11. Subsonic Switch(On/Off)

12. Variable Subsonic Filter- 20Hz~50Hz)

13. Bass Boost Frequency- This control adjusts the frequency to be boosted from(40Hz~100Hz)

14. Bridged Switch(Master/Slave)

15. Phase Shift control - Allows you to change the phase of your subwoofer from 0 to 180 degrees to help compensate for timing differences between drivers.

SYSTEM WIRING

▪ 2 CHANNEL STEREO CONFIGURATION

OPTI 600 x 2HC

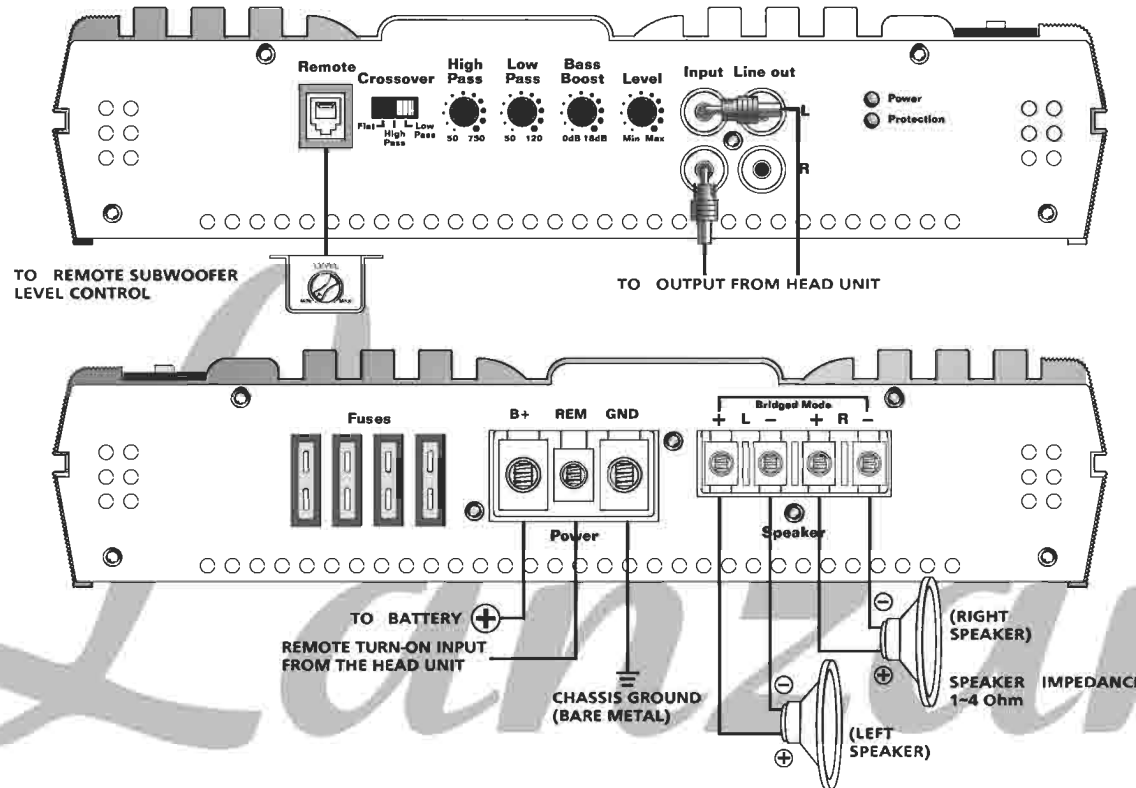

OPTI SYSTEM WIRING

2 CHANNEL BRIDGED MODE CONFIGURATION

OPTI 600 x 2HC

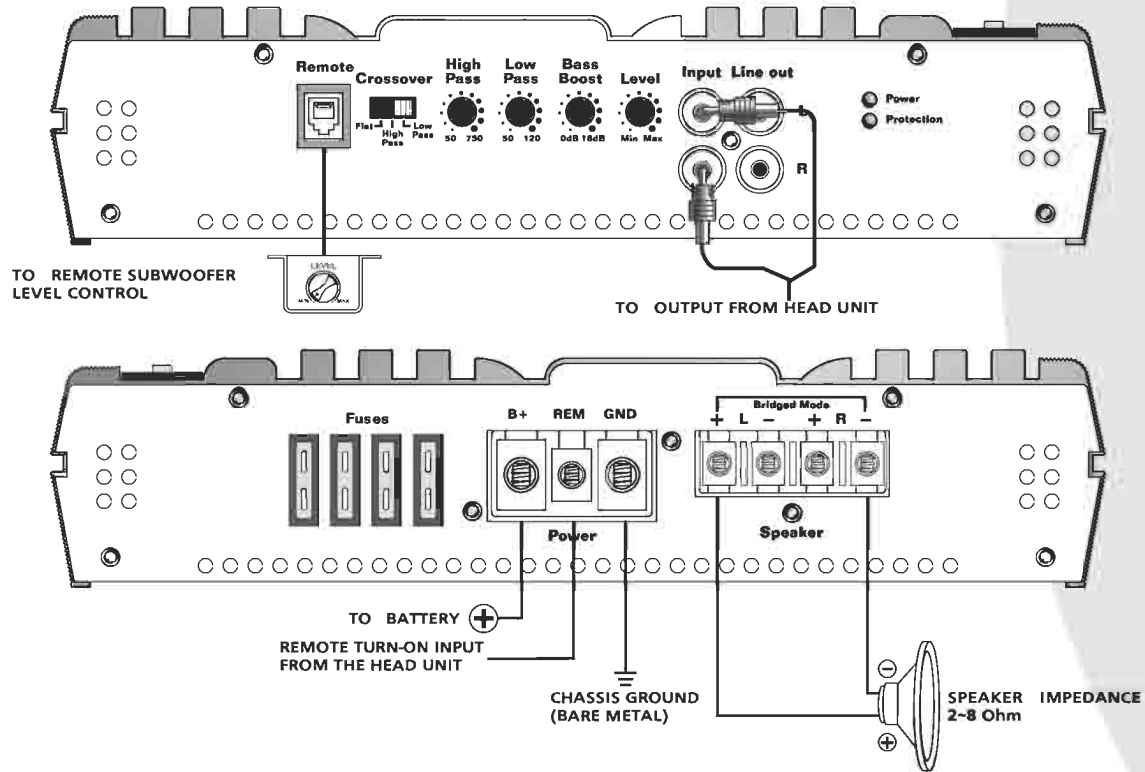

SYSTEM WIRING

▪ 2 CHANNEL TRI-MODE CONFIGURATION

OPTI 600 x 2HC

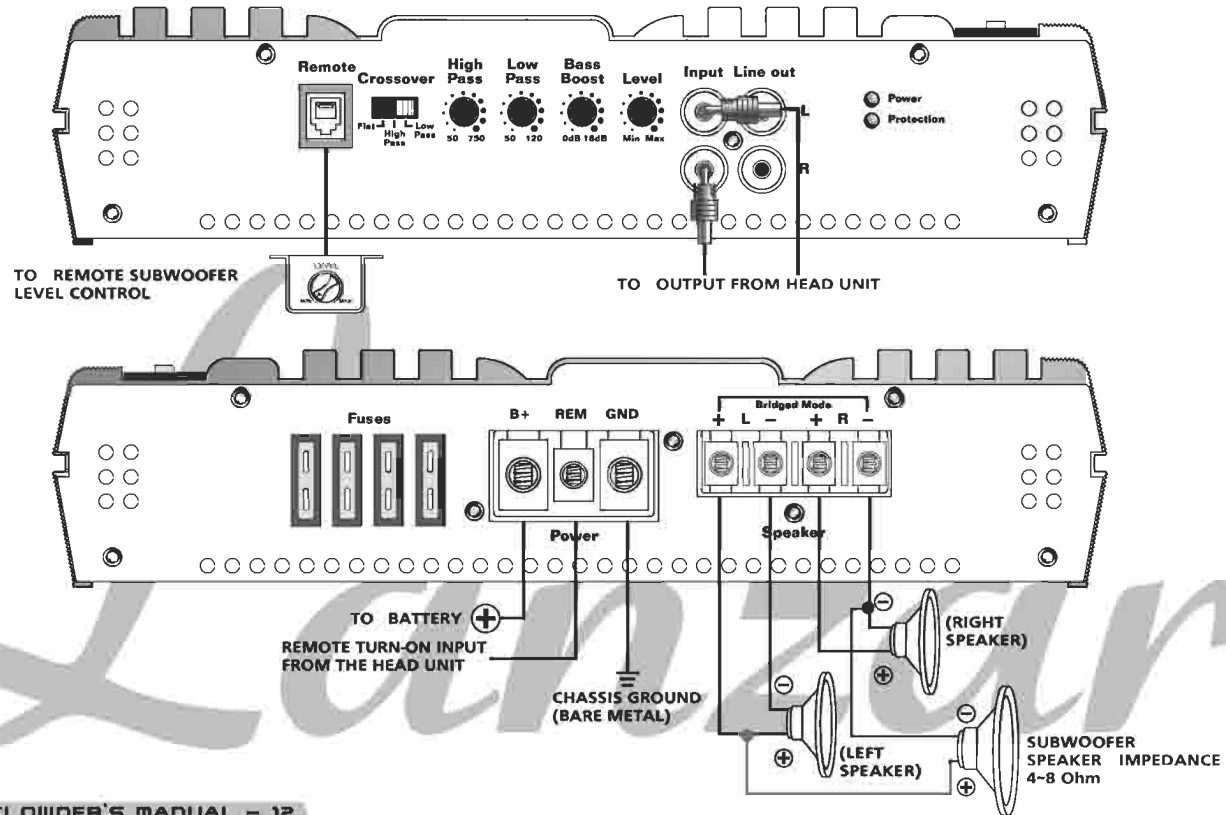

OPTI SYSTEM WIRING

4 CHANNEL STEREO CONFIGURATION

OPTI 400 x 4HC

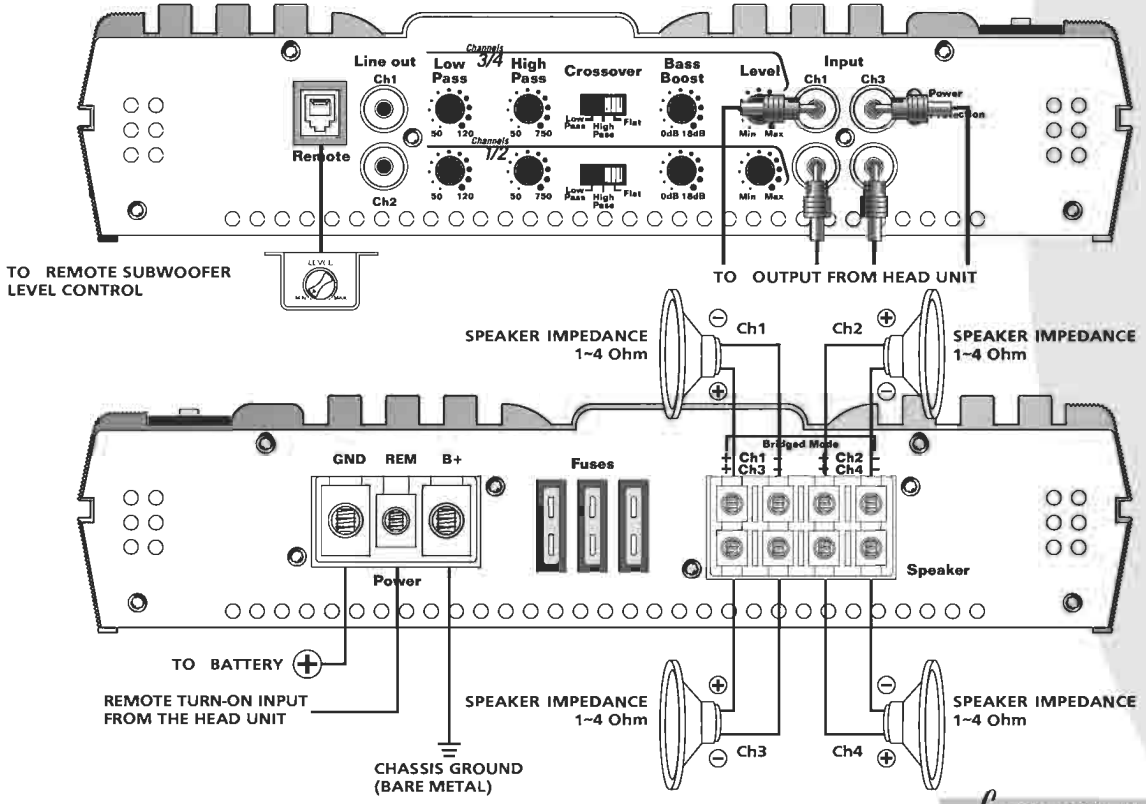

SYSTEM WIRING

▪ 4 CHANNEL BRIDGED MODE CONFIGURATION

OPTI 400 x 4HC

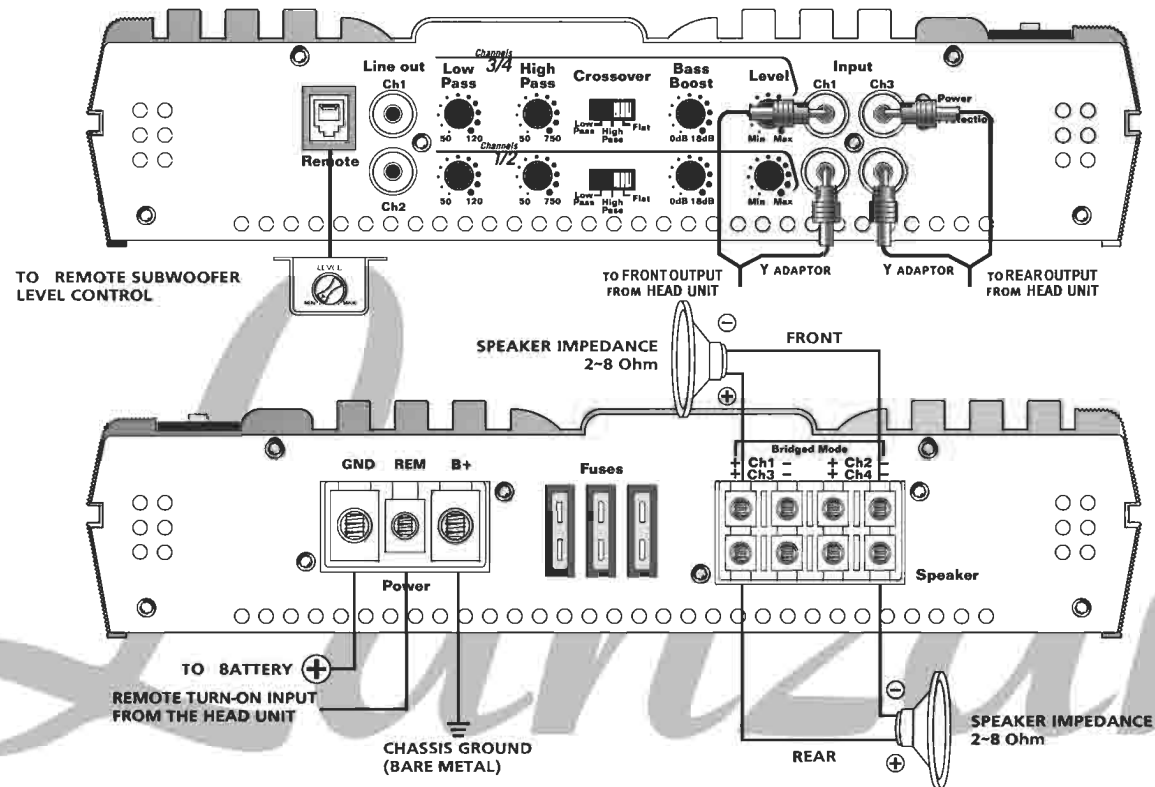

SYSTEM WIRING

▪ MONO MODE CONFIGURATION

OPTI 1200HC/2200HC

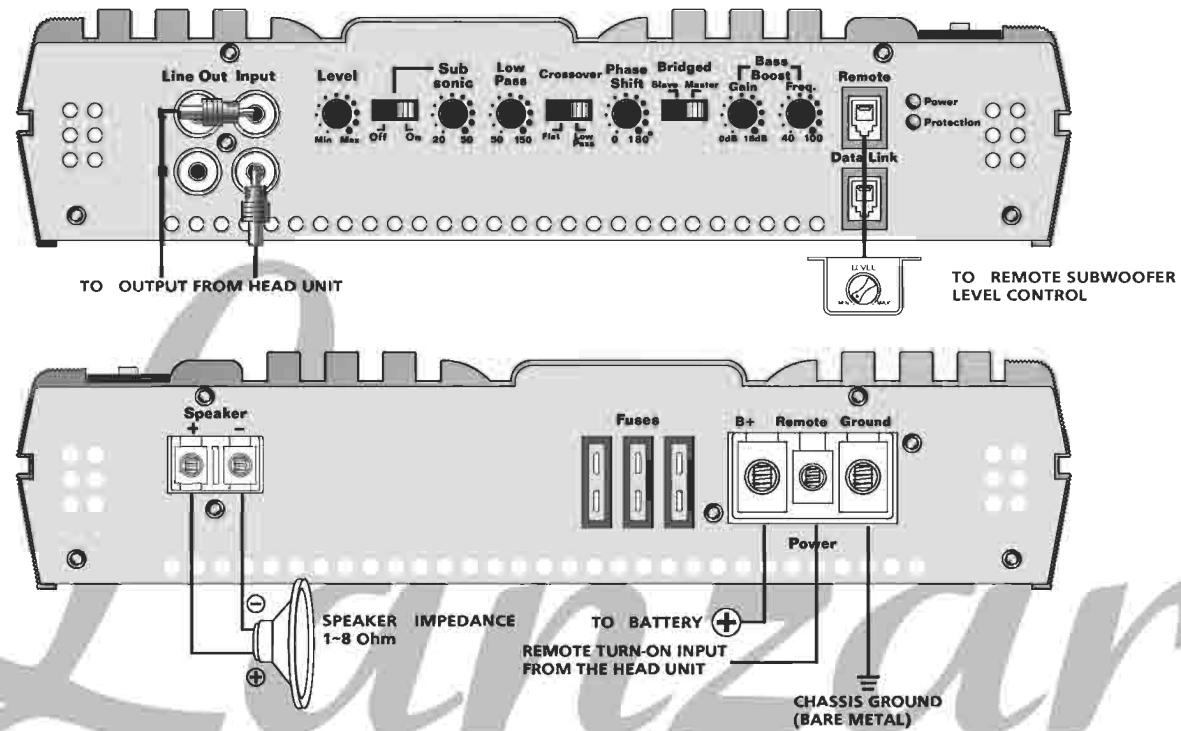

OPTI SYSTEM WIRING

MONO BRIDGED TWO AMPLIFIER

OPTI 1200HC/2200HC

Master Amp

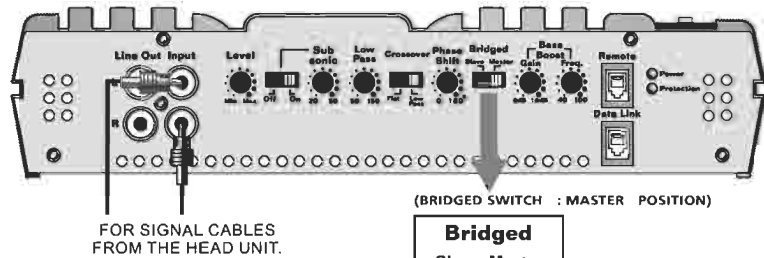

Slave Amp

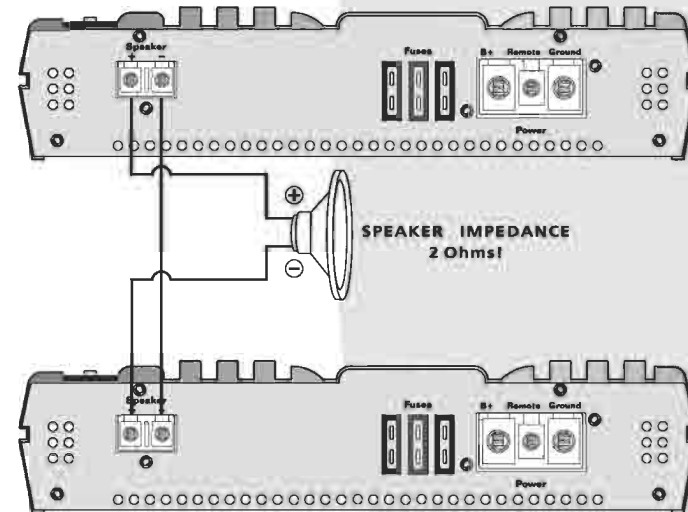
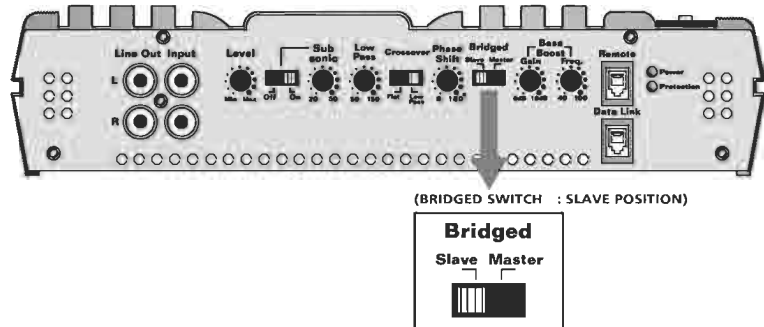

TROUBLESHOOTING

Before removing your amplifier, refer to the list below and follow the suggested procedures. Always test the speakers and their wires first.

AMPLIFIER WILL NOT POWER UP.

Check for good ground connection.

Check that remote DC terminal has at least 13.8v DC.

Check that there is battery power on the +terminal.

Check all fuses.

Check that Protection LED is not lit. If it is lit, shut off amplifier briefly and then repower it.

HIGH HISS OR ENGINE NOISE (ALTERNATOR WHINE) IN SPEAKERS.

Disconnect all RCA inputs to the amplifier(s)-if hiss / noise disappears, then plug in the component driving the amplifier and unplug its inputs. If hiss / noise disappears, go on until the faulty / noisy component is found.

It is best to set the amplifier's input level as insensitive as possible. The best subjective S/N ratio is obtainable this way. Try to drive as high a signal level from the head unit as possible.

Opti

PROTECTION LED COMES ON WHEN THE AMPLIFIER IS POWERED UP.

Check for shorts on speaker leads.

Check that the volume control on the head unit is turned down low.

Remove speaker leads, and reset the amplifier. If the Protection LED still comes on, then the amplifier is faulty.

AMPLIFIER(S) GETS VERY HOT.

Check that the minimum speaker impedance for that model is correct.

Check for speaker shorts.

Check that there is good airflow around the amplifier. In some applications, an external cooling fan may be required.

DISTORTED SOUND

Check that the Level control(s) is set to match the signal level of the head unit.

Check that all crossover frequencies have been properly set.

Check for shorts on the speaker leads.

HIGH SQUEAL NOISE FROM SPEAKERS.

This is always caused by a poorly-grounded RCA patch cord.

Lanzar

Lanzar OPTI OWNER'S MANUAL

Opti

Lanzar OPTI OWNER'S MANUAL

opti

Lanzar Audio Inc.
1600 63rd Street, Brooklyn, NY 11204
(718)535-1800
www.lanzar.com

PRINTED IN KOREA

Free Manuals Download Website

<http://myh66.com>

<http://usermanuals.us>

<http://www.somanuals.com>

<http://www.4manuals.cc>

<http://www.manual-lib.com>

<http://www.404manual.com>

<http://www.luxmanual.com>

<http://aubethermostatmanual.com>

Golf course search by state

<http://golfingnear.com>

Email search by domain

<http://emailbydomain.com>

Auto manuals search

<http://auto.somanuals.com>

TV manuals search

<http://tv.somanuals.com>