

Lanzar®



# OPTIDRIVE



user's manual

[www.lanzar.com](http://www.lanzar.com)

## **OptiX-3B**

**3-Way Electronic Crossover Network  
w/Remote Bass Boost and Level Control**



## INTRODUCTION...

Congratulations on your purchase of a new Lanzar Opti signal processor. Opti mobile electronics are some of the most advanced car audio products available. These quality audio products are designed and engineered to afford you years of uncompromising musical service. Lanzar has utilized the latest electronic technologies in order to deliver a superb listening experience.

The X-3B Active Crossover offers the listener the ability to enjoy the finest in mobile audio. The X-3B unleashes the effortless, natural and open quality of the real performance. Car audio systems which utilize passive crossovers feed the music through chokes and capacitors, which creates a “bottleneck” through which the music must pass. Portions of the program material may pass through at different speeds, creating distortion – some of the music doesn’t make it through at all!

With the Lanzar Opti X-3B you’ll hear all the dynamics in the bass, and still hear delicacies like fingers sliding across guitar strings. The X-3B also allows the user to group amplifiers and separate speakers in discrete assemblages so they play as one cohesive unit, in harmony with each other. The X-3B becomes the music conductor in the system, balancing volume, assigning the proper part of the music to a specific instrument, delaying some sounds so they reach your ear just as the rest of the music does, with the sole purpose of creating the illusion that there is only the music.



## table of contents

<b>general features</b>	<b>2</b>
<b>precautions</b>	<b>3</b>
<b>features and specifications</b>	<b>4-5</b>
<b>system wiring</b>	<b>6</b>
<b>mounting and installation</b>	<b>7</b>
<b>noise check and system adjustment</b>	<b>8</b>
<b>troubleshooting</b>	<b>9</b>

Lanzar®

## general features

*Blue light illuminated control panel*

*Rotary control knobs*

*12dB per octave crossover slopes*

*PWM power supply*

*Remote bass boost (0-+18dB) and level controls*

*Subwoofer mode switch*

*Variable subwoofer frequency control 40-400 Hz*

*Parametric "Q" control (2-20)*

*Variable bass boost frequency control 25-250 Hz*

*Subwoofer stereo/mono mode control*

*Variable high-pass frequency control (mid-range) 40-800Hz*

*Variable low-pass frequency control (mid-range) 2k-7 kHz*

*Band pass/ high pass selector*

*Left and right mid range phase shift control (0-180)*

*Variable high-pass frequency control (40-8 kHz)*

*X1, X10 high pass frequency multiplier-switch*

*High-pass, mid-range & subwoofer output level controls*

*Mid/high & sub RCA inputs*

*High, mid & sub RCA outputs*

*Max Variable output level controls, 7 volts*



# *Lanzar*® Precautions

To prevent short circuits, be sure to disconnect the negative battery ground lead before wiring the system up.

When you finish the installation, be sure to make one more check to be sure everything is done correctly.

Reinstate all car parts that were removed.

Reconnect the negative battery ground lead.



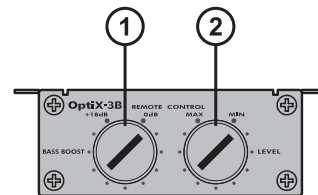
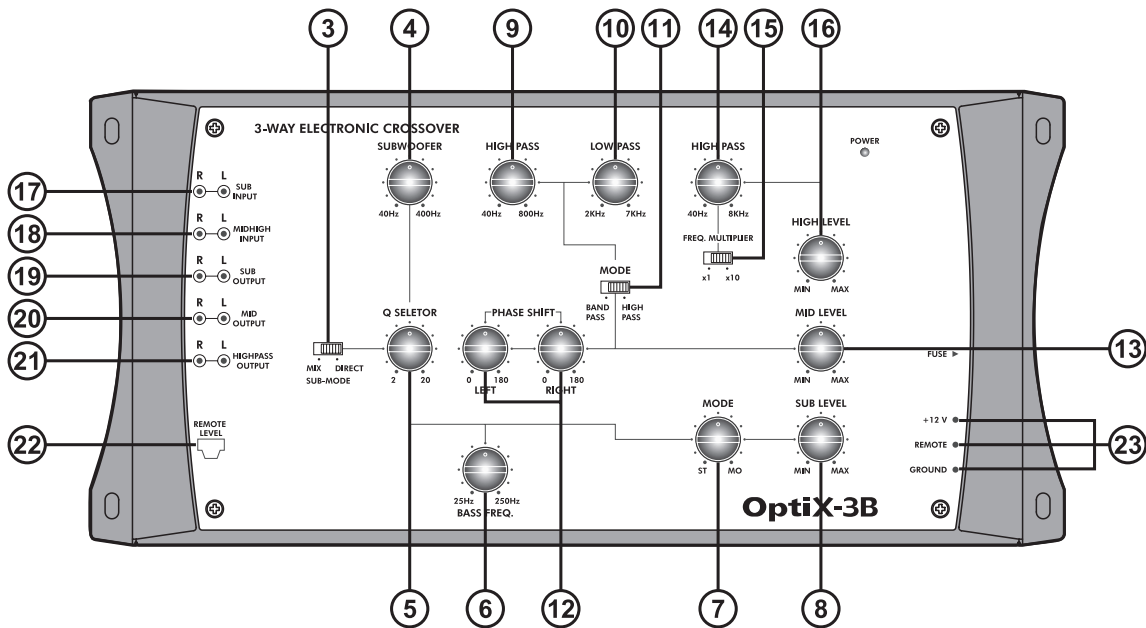

- 1. BASS BOOST CONTROL** This control adjusts the bass boost gain (0 to +18dB).
- 2. BASS BOOST LEVEL CONTROL** This control sets the subwoofer gain control.
- 3. SUBWOOFER MODE SWITCH** Allows subwoofer mode channel to receive signal from either the mix of from low-pass inputs directly (when head unit has appropriate 5ch/6ch outputs).
- 4. VARIABLE SUBWOOFER FREQUENCY CONTROL 40Hz-400Hz** By turning the selector you can choose the subwoofer crossover points from 40Hz-400Hz.
- 5. PARAMETER "Q" CONTROL 2-20** Allows independent continuous change of the boost frequency bandwidth (Q-factor) for each band from Q=20 (Narrow bandwidth, steep slope) to Q=2 (Wide bandwidth, gentle slope).
- 6. VARIABLE SUBWOOFER BASS BOOST FREQUENCY CONTROL 25Hz-250Hz** By turning the selector you can choose the subwoofer crossover bass boost points from 25Hz-250Hz.
- 7. SUBWOOFER STEREO/MONO MODE CONTROL** For selection of stereo or mono mode subwoofer output.
- 8. SUBWOOFER OUTPUT LEVEL CONTROL** For adjusting the subwoofer channel output level.
- 9. VARIABLE HIGH-PASS (MID-RANGE) FREQUENCY CONTROL 40-800Hz** By turning the selector you can choose the high-pass crossover points from 40Hz-800Hz.
- 10. VARIABLE LOW-PASS (MID-RANGE) FREQUENCY CONTROL 2KHz-7KHz** By turning the selector you can choose the low-pass crossover points from 2KHz-7KHz.
- 11. BAND PASS/HIGH PASS SELECTOR** When this switch is in high pass mode, the low pass filter cannot be used. It can convert rear channel to band pass in tri amp system.
- 12. LEFT AND RIGHT HIGH & LOW PASS PHASE SHIFT CONTROL 0-180** Allows you to change the phase of your high and low crossover from 0 to 180 degrees to help compensate for timing difference between drivers.
- 13. MID-RANGE OUTPUT LEVEL CONTROL** For adjusting the mid-range channel output level.
- 14. VARIABLE HIGH-PASS FREQUENCY CONTROL 40-8KHz** By turning the selector you can choose the high-pass crossover points from 40Hz-800Hz.
- 15. FREQUENCY MULTIPLIER (x1/x10 HIGH-PASS CROSSOVER)** This switch changes crossover points from 40Hz-800Hz to 400Hz-8KHz for high frequency high channel drivers.
- 16. HIGH-PASS OUTPUT LEVEL CONTROL** For adjusting the high pass channel output level.
- 17. SUBWOOFER INPUT PORT** To be connected to the subwoofer outputs of the source unit.
- 18. MID/HIGH INPUT PORT** To be connected to the outputs of the source unit.
- 19. SUBWOOFER OUTPUT PORT** To be connected to the subwoofer channel amplifier left/right inputs.
- 20. MID OUTPUT PORT** To be connected to the rear channel amplifier left/right inputs.
- 21. HIGH PASS OUTPUT PORT** To be connected to the front channel amplifier left/right inputs.
- 22. REMOTE CONTROL JACK** Plug the modular telephone style cord connected to the remote control unit into this jack.
- 23. POWER TERMINALS** Use these connectors to deliver power, ground, and remote turn-on control to the unit.

## Adjustable Bass Boost

**Frequency** 25Hz-250Hz

**Adjustable Bass Boost** 0-18dB

**Adjustable Q Control** 2-20

## Selectable Crossover

### Frequency

**-High Pass** 40Hz-8KHz

**-Mid High Pass** 40Hz-800Hz

**-Mid Low Pass** 2KHz-7KHz

**-Subwoofer (Low Pass)** 40Hz-400Hz

**Power Supply** 10-16V DC, negative ground

**Input Impedance** 10K Ohm

**S/N ratio** more than 85dB

**Slope Rate** 12dB/Octave

**Max Output Signal Level** 7.0V/RMS

**Channel Separation** 60dB

**Distortion** less than 0.05%

**Dimensions, WxDxH, inches** 6x12-11/16x1-3/4

**(millimeters)** (150 x 322 x 45)

## REMOTE CONTROL UNIT

### 1. BASS BOOST

This control sets the Bass Boost Gain from 0 to +18dB.

### 2. BASS LEVEL

This control sets the subwoofer level control.



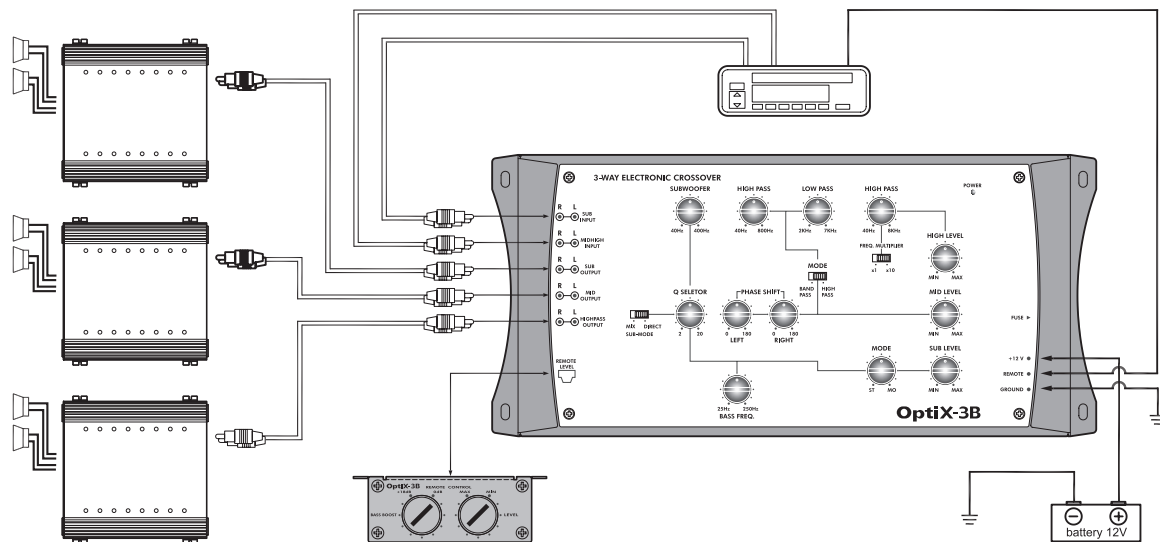

### SUB MODE SELECTOR

SWITCH POSITION	VIA INPUT SOURCE	OUTPUT SUBWOOFER
DIRECT	FRONT	OFF
	REAR	ON
MIX	FRONT	ON
	REAR	OFF

Subwoofer mode switch: allows sub-woofer mode channel to receive signal from either, the mix of from front inputs, the direct from rear inputs.



Your new Opti Series Crossover comes complete with all required mounting hardware.

Mark the location for the mounting screw holes by positioning the Crossover where you wish to install it and use a scribe (or one of the mounting screws) inserted in each of the mounting holes to mark the mounting surface. If the mounting surface is carpeted, measure the hole centers and mark with a felt tip pen.

Before attempting to drill the mounting holes, take note of any wires, lines or other devices in your vehicle which may be located behind the mounting surface! Then drill pilot in the mounting surface for the mounting screws and insert them. Tighten the screws securely.

### Installation

- A red 18 gauge stranded or heavier and insulated wire should be connected to the terminal marked +12V. Wire an in-line fuse holder on this lead as it is the 12 Volts DC wire for the system. This wire should be connected to your vehicle's battery. If a wire is run directly to the battery make sure to install an in-line fuse on this wire within 12" from the battery.
- A black stranded wire of at least 18 gauge should be connected to the terminal marked Ground. This is the ground wire for the X-3B and should be attached to the same ground point with the amplifiers in the system. Keeping this ground wire as short as possible improves the electrical circuit and keeps ground related noise problems to a minimum.
- An orange stranded wire of a least 20 gauge should be connected to the terminal marked Remote. This wire connects to your head unit's remote out or power antenna lead out. This wire should supply 12 Volts DC any time the radio, cd or cassette are playing. This lead must also be connected to any other components in your system that utilize a remote turn-on lead for powering up.
- Connect all line inputs and outputs using high-quality RCA-RCA cables.
- Recheck all connections before powering up.
- Set all level controls to their least sensitive positions and set all crossover controls, switches, etc. to the desired frequency or position.
- Once the system is powered up, set the volume control on the head unit to about the 2 o'clock position, and then set all the amplifiers' level controls for half output level.

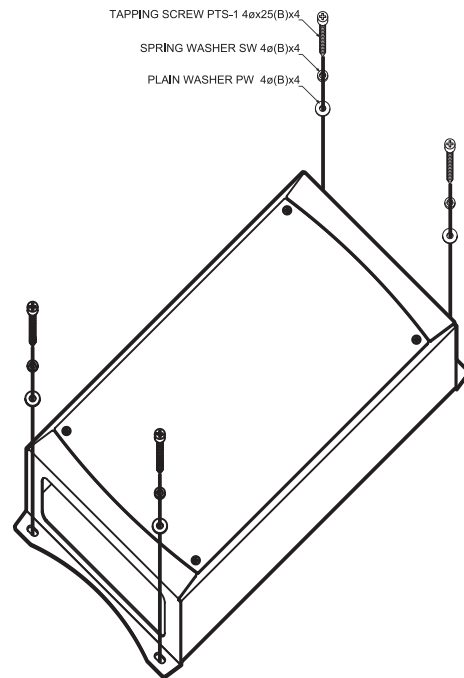

# Lanzar® Noise check and system adjustment

## NOISE CHECK

Check the entire audio system for noise before permanently securing the CROSSOVER mounting

1. Start the engine.
2. Turn the audio system on.
3. Rev the engine and vary the VOLUME of the audio system to determine if there is any unwanted noise.  
If so, turn both the audio system and the engine off. Do not secure the CROSSOVER mounting screws. Refer to the "Trouble Shooting Guide" at this manual.
4. If the audio system does not have any noise, securely tighten the CROSSOVER mounting screw and double check the wiring cables for safe placement.

## SYSTEM ADJUSTMENT

Preliminary Adjustments

Pre-setting the system provides a necessary starting point for fine-tuning the entire audio system to maximum performance.

**NOTE: DO NOT MOUNT CROSSOVER UNTIL THE FOLLOWING PROCEDURES HAVE BEEN COMPLETED.**

1. Preset each amplifier input gain adjustment at the amplifier to half of maximum.
2. Before turning the audio system on, preset-adjust the high, mid and sub-woofer output level controls.
3. Slowly turn the volume up and listen carefully for: obvious trouble in sound (distortion, no sound, no hiss, total silence). Turn the system off refer to "Trouble Shooting Guide" at this manual.

## Caution

**DO NOT ROUTE AUDIO CABLES AND POWER CABLES TOGETHER! THIS CAN CAUSE ENGINE NOISE IN YOUR AUDIO SYSTEM. ALWAYS DISCONNECT THE SYSTEM FROM THE BATTERY BEFORE ATTEMPTING TO MAKE OR ALTER ANY CONNECTIONS. THIS PRODUCT IS DESIGNED FOR USE IN ANY 12 VOLTS NEGATIVE GROUND ELECTRICAL SYSTEM ONLY. INSTALLING THIS PRODUCT IN ANY POSITIVE GROUND ELECTRICAL SYSTEM COULD SERIOUSLY DAMAGE THE AUDIO SYSTEM.**



PROBLEM	POSSIBLE CAUSE
1. There is an audible distortion at a low volume level.	<ul style="list-style-type: none"><li>• Output levels NOT set correctly.</li><li>• Crossover frequencies NOT set correctly.</li><li>• Check for shorts on the speaker leads.</li></ul>
2. A whining sound can be heard through the speakers when the audio system is at low volume with the engine running. The whining noise remains unchanged or seems to disappear when the volume level is increased.	<ul style="list-style-type: none"><li>• Check the red power wire. It must be connected directly to the battery.</li><li>• Check the system's ground point. It must make good contact with chassis ground (bare metal).</li><li>• The radio and the CROSSOVER must be grounded at the same reference point.</li></ul>
3. There is a "motor boating" type of sound when the engine is running and the audio system volume is set at a reasonably high level.	<ul style="list-style-type: none"><li>• Check the red power wire. It must be connected directly to the battery.</li><li>• Check the system's ground point. It must make good contact with chassis ground (bare metal).</li></ul>
4. High squeal noise from speakers	<ul style="list-style-type: none"><li>• This is almost always caused by a poorly - grounded RCA patch cord.</li></ul>



# limited warranty policy

## C R O S S O V E R

All Lanzar Signal Processors are carefully constructed and thoroughly tested before shipment. Units purchased in the USA are warranted to be free of defects in material and workmanship for three (3) years from the date of purchase. This warranty is limited to the original retail purchaser of the Signal Processor.

Should the unit fail due to a factory defect in material or workmanship, your unit will be repaired or replaced at the sole discretion of Lanzar.

To obtain warranty service, you must first call our Consumer Return Hotline number at (718) 236-6948 to obtain a Return Authorization (RA) number. This RA Number must appear on the outside of your package and on all paperwork relating to your return.

When returning the unit to us for warranty service, it must be carefully packed and shipped prepaid to:

**R.A. # \_\_\_\_\_**  
**Lanzar Service Center**  
**1600 63rd Street**  
**Brooklyn, NY 11204**

**www.lanzar.com**

### **You must also include the following items with your return:**

- A copy of your sales receipt or other proof of purchase
- A brief letter indicating the problem you are experiencing with the product
- Include in your letter your return address, daytime phone number and RA Number
- Also include a check or money order for \$20.00 for return shipping, handling and insurance, or provide your VISA/MasterCard number with expiration date.

Our obligation under this warranty is limited to the repair or replacement of the defective unit when it is returned to us prepaid. This warranty will be considered void if the unit was tampered with, improperly serviced, or subject to misuse, neglect or accidental damage.

All implied warranties of merchantability and fitness for a particular purpose are limited in duration to the length of the warranty. Lanzar expressly disclaims any liability for incidental or consequential damages caused by product defects. This warranty does not cover any expense incurred in the removal and/or reinstallation of the Signal Processor. Lanzar's total liability will not exceed the purchase price of the Signal Processor.

Some states do not allow the exclusion or limitation of incidental or consequential damages, or limitations on how long an implied warranty lasts, so the above limitations and exclusions may not apply to you. This warranty gives you specific legal rights, and you may also have other rights which vary from state to state.

## Free Manuals Download Website

<http://myh66.com>

<http://usermanuals.us>

<http://www.somanuals.com>

<http://www.4manuals.cc>

<http://www.manual-lib.com>

<http://www.404manual.com>

<http://www.luxmanual.com>

<http://aubethermostatmanual.com>

Golf course search by state

<http://golfingnear.com>

Email search by domain

<http://emailbydomain.com>

Auto manuals search

<http://auto.somanuals.com>

TV manuals search

<http://tv.somanuals.com>