

Network Management Card (66102 & 66103)

User manual

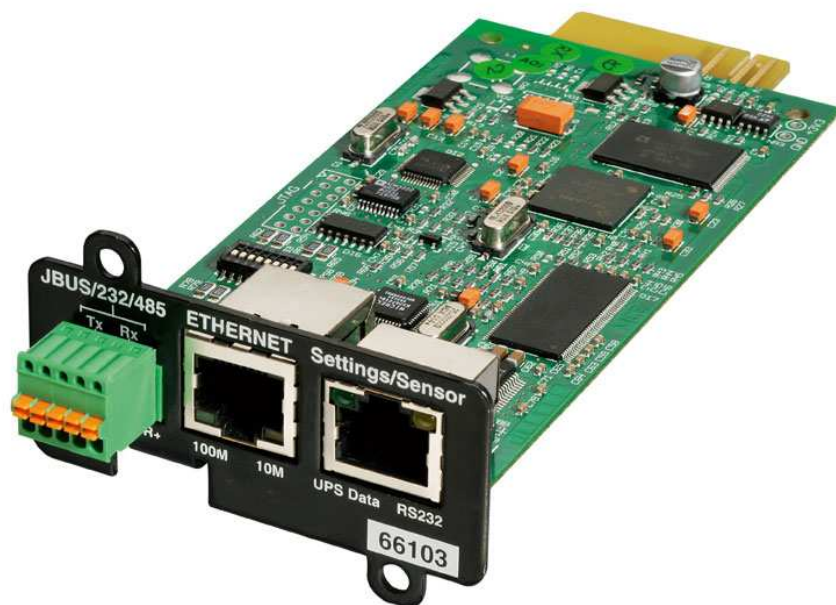
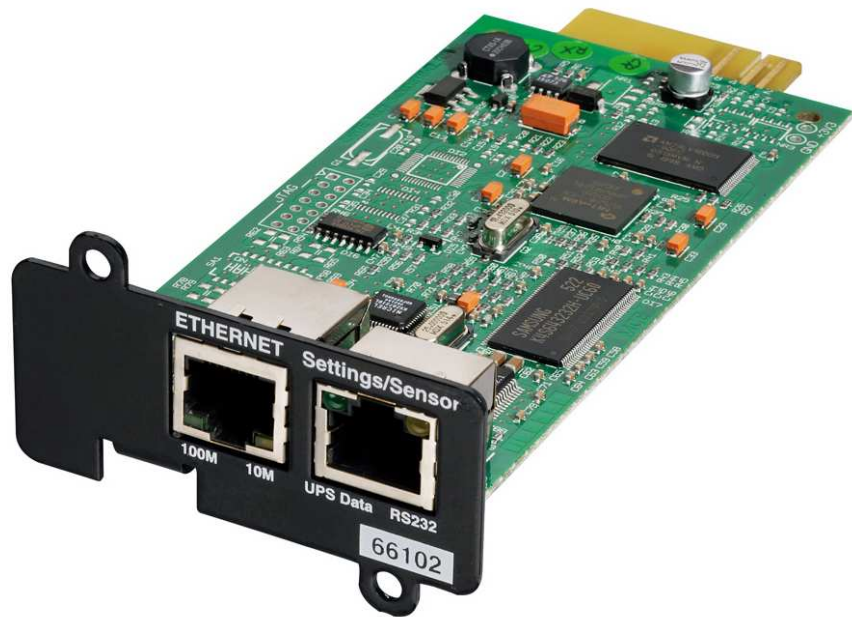

Contents

1	MGE OFFICE PROTECTION SYSTEMS NETWORK SOLUTION	5
1.1	GENERAL PRESENTATION	5
1.1.1	Connecting the UPS to the Ethernet network	6
1.1.2	Protection of the computers/servers	6
1.1.3	Supervision of the UPSs over the network	7
1.1.4	Connection	7
1.2	PRESENTATION OF THE NETWORK MANAGEMENT CARD (NMC)	8
1.2.1	Compatibility with UPSs	8
1.2.2	Direct sending of E-mail	9
1.2.3	Sending text messages (SMS)	9
1.2.4	Compatibility with the Network Management Systems (NMS) – Trap sending	9
1.2.5	Environment Sensor (option)	9
1.3	TECHNICAL DATA	10
1.3.1	Hardware characteristics	10
1.3.2	EMC Compatibility	10
1.3.3	Configuration	10
1.3.4	Administration	11
1.3.5	Network	11
1.3.6	Environment sensor	11
1.3.7	MIB (Management Information Base)	12
1.3.8	Default parameters	13
2	INSTALLATION	14
2.1	UNPACKING AND CHECK ON CONTENTS	14
2.2	INDICATIONS	14
2.3	INSTALLATION IN THE UPS	15
2.4	SENSOR INSTALLATION (OPTION)	16
3	CONFIGURATION	17
3.1	CONFIGURE IP PARAMETERS	17
3.1.1	Your network is equipped with a DHCP server	18
3.1.2	Your network is not equipped with a DHCP server	19
3.2	TEST AFTER CONFIGURATION	19
4	SUPERVISION AND ADMINISTRATION BY BROWSER	20
4.1	OPTIMISING THE PERFORMANCE OF YOUR BROWSER	20
4.2	UPS	21
4.2.1	UPS properties page	21
4.2.2	On-line help	33
4.2.3	UPS control	34
4.2.4	UPS weekly schedule programming	37
4.2.5	Shutdown parameters	38
4.2.6	Measurements	40
4.2.7	Event log	41
4.2.8	System log	42
4.3	NOTIFICATION	43

ENERGIZE YOUR ENTERPRISE

Network Management Card – User Manual

34003991EN/DA

Page 2/120

4.3.1	Email Notification	43
4.3.2	E-mail Message Settings	45
4.4	CONFIGURATION	47
4.4.1	Network settings	48
4.4.2	System	50
4.4.3	Notified Applications	52
4.4.4	Central shutdown configuration	54
4.4.5	Access control	55
4.4.6	Date and time	57
4.4.7	Firmware upload	59
4.5	ENVIRONMENT SENSOR (OPTION)	60
4.5.1	Characteristics	60
4.5.2	Environment Status	61
4.5.3	Environment Settings	62
4.5.4	Log	64
5	SERVER PROTECTION	65
5.1	SET-UP OF THE SHUTDOWN PARAMETERS	65
5.1.1	Shutdown criteria managed by the Network Management Card	65
5.1.2	Controlled outlets	68
5.1.3	Protection of a server connected to a controlled outlet	68
5.2	THE DIFFERENT SERVER AND UPS SHUTDOWN SEQUENCES	69
5.2.1	Extended power outage, shutdown initiated by the Shutdown Timer (Shutdown after)	69
5.2.2	Extended power outage, shutdown initiated by the "Low battery power" message	69
5.2.3	Case of power restoration before the end of the "shutdown duration" counter	70
5.3	SHUTDOWN MANAGEMENT WITH 2 NMC BOARDS	71
5.3.1	Shutdown Duration	71
5.3.2	Settings	71
6	CONFIGURATION VIA RS232	72
6.1	CHOICE 1: RESTART / RESET	73
6.2	CHOICE 2: NETWORK CONFIGURATION	73
6.2.1	Choice 1: Read Network settings	73
6.2.2	Choice 2: Modify Network settings	74
6.2.3	Choice 3: Set Ethernet speed	74
6.3	CHOICE 3: LOST PASSWORD / SET LOGIN PASSWORD TO DEFAULT	75
6.4	CHOICE 4: RETURN TO DEFAULT CONFIGURATION	76
7	INDUSTRIAL NETWORK MANAGEMENT CARD (INMC OPTION)	77
7.1	PRESENTATION	77
7.1.1	Overview	77
7.1.2	Functions	77
7.1.3	Technical characteristics	78
7.2	INSTALLATION	79
7.2.1	RS232 link configuration and connection	79
7.2.2	RS485 link configuration and connection	80
7.2.3	Configuration of the JBUS/MODBUS communication parameters	86
7.3	ADDITIONAL WEB PAGES	90

7.4	JBUS TABLE	91
7.4.1	Data for Pulsar 700 / 1000 / 1500	91
7.4.2	Data for Pulsar M 2200 / 3000	93
7.4.3	Data for Pulsar MX 4000 / 5000 / 10000	95
7.4.4	Data for Pulsar MX frame 15 / 20	97
7.4.5	Sensor data	102
7.4.6	Other data	105
8	APPENDICES	106
8.1	TABLES OF ALARMS AND EVENTS	106
8.1.1	Table of alarms	106
8.1.2	Table of UPS events	109
8.1.3	Table of system alarms	111
8.2	SNMP OBJECTS	112
8.2.1	MGE MIB	112
8.2.2	Table des TRAPS : (1.3.6.1.4.1.705.1.11)	115
9	GLOSSARY	117

1 MGE Office Protection Systems Network Solution

1.1 General Presentation

MGE Office Protection Systems Network Solution:

provides information on events concerning the supply of power to the computers connected to your computer network,

carries out automatic shutdown of computer systems,

monitors and controls all the UPSs connected to the network.

As illustrated in the picture below, MGE Office Protection Systems Network Solution provides these 3 main functions:

supervision of the UPSs over the Network,

protection of the computers,

connexion of the UPS to the Network.

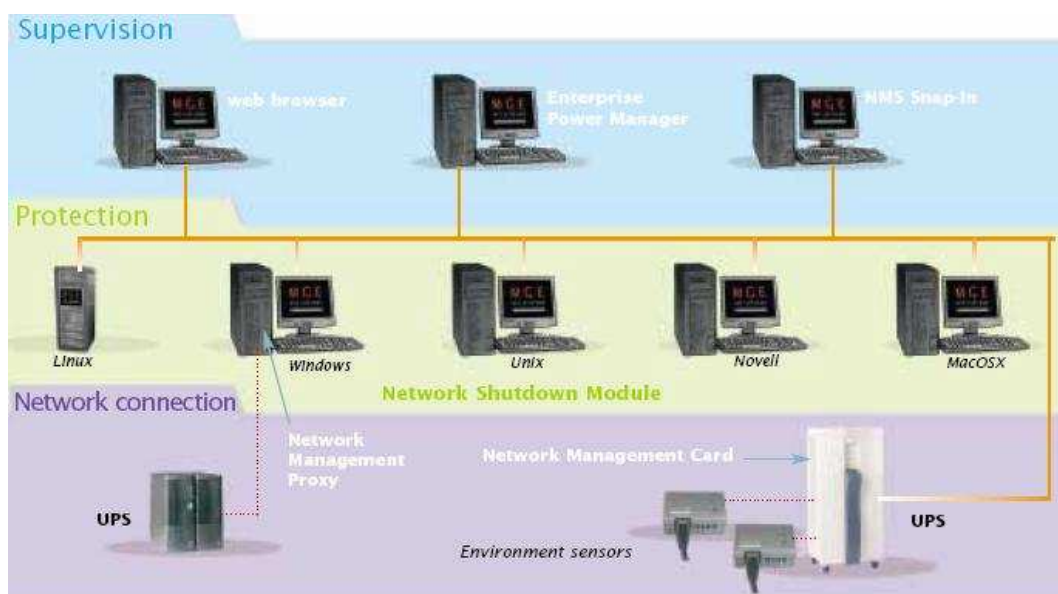

1.1.1 Connecting the UPS to the Ethernet network

This function can be performed either through network Cards inserted in the UPS (Network Management Card) or through a software "agent" running on a nearby PC that is called the Network Management Proxy.

The Network Management Card or Proxy:

- manages communication with the UPS (as well as local protection of the machine on which Proxy is installed)
- periodically accesses the information concerning the UPS
- makes this information available to the connected applications (Network Shutdown Modules, Web Browser, Network Management Systems, Enterprise Power Manager)
- sends notifications on certain events.

Operation may be in standard secure mode (the default mode) or in SSL secure mode (Secure Socket Layer SSL).

1.1.2 Protection of the computers/servers

This function is performed by the Network Shutdown Module installed on each of the servers to be protected.

Note that the Shutdown Module is available on several Operating Systems.

The Network Shutdown Module:

Continuously waits for information from the Network Management Card/Proxy connected to the MGE Office Protection Systems.

Warns administrators and users if AC power fails and proceeds with graceful system shutdown before the end of battery backup power is reached.

1.1.3 Supervision of the UPSs over the network

Depending on your needs, you can either use:

Your Internet browser to monitor each UPS, as Management Proxy and Management Card includes a Web server
Your company's standard Network Management System (HP-Openview, CA Unicenter, HP Insight Manager, IBM Tivoli Netview)

To simplify integration of MGE Office Protection Systems UPSs, you can use one of the Network Management System Kits for MGE devices. These kits are available on the Management Pac 2 CD-ROM. (ref 66923)

The MGE supervisor "Enterprise Power Manager".

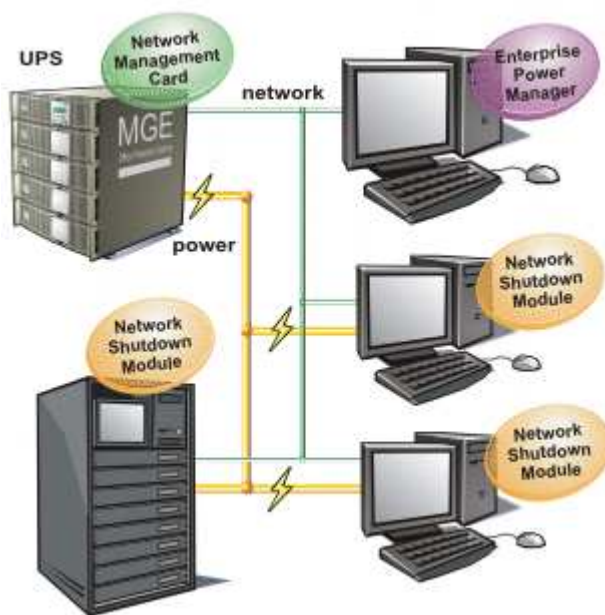

1.1.4 Connection

Before installing the MGE Office Protection Systems Network Solution, the UPS must be set up as indicated in the steps below.

Shut down the computers to be protected by the UPS.

Connect the UPS to a wall outlet. (For UPSs above 3kVA, please refer to the UPS installation manual).

Connect the power cord of each computer to an outlet on the UPS. (For UPSs above 3kVA, please refer to the UPS installation manual)

1.1.4.1 How to connect UPS / agent / network:

Insert the optional card in the UPS and connect the UPS to the computer network.
Start the MGE Office Protection Systems UPS, then the computers.

1.1.4.2 Setting up the protection:

Set up the Network Management Card (see user manual).

Install and configure the Network Shutdown Module on all machines that are to be protected by the UPS.

The software components for each platform and the user manuals are on the Solution-Pac-2 CD or are available for download on the www.mgeops.com Web site, in the “Downloads” section.

1.2 Presentation of the Network Management Card (NMC)

1.2.1 Compatibility with UPSs

The Minislot Network Management Card is compatible with the following UPSs:

Pulsar Evolution 500/800/1100	From technical level 06
Pulsar Evolution 2200/3000	From technical level 05
Pulsar Evolution 1500	From technical level 05
EXtreme C 700/1000/1500	From technical level B2
EXtreme C 2200 - 3200	From technical level 02
Pulsar EX 700/1000/1500 RT (US ⁹)	From technical level 03
Pulsar EX 2200/3200 (US)	From technical level 09
Pulsar M 2200/3000	All models
Pulsar 700/1000/1500	All models
Evolution 650/850/1150/1550/2000	All models
Evolution S 1250/1750/2500/3000	All models
Pulsar MX 4/5/10	All models
Pulsar MX 15/20	All models
EX 5 / 7 / 11 RT	Equipped with a card minislot (Q2 08)
EX 5 / 7 / 11 RT 3 : 1	Equipped with a card minislot (Q2 08)

Note:

If the UPS's NT is below that indicated in the table above, contact MGE's Office Protection Systems technical support.
The Network Management Card (66102) is not compatible with Pulsar EX 7/10, Pulsar EX 15/20/30, Pulsar ESV+, 8/11/14/22 ranges.

Network Management Cards acquire information on the operation status of the UPS systems and provide remote control of these systems

by means of an ETHERNET network from any SNMP administration station or Web browser.

They also supply alarms to the Network Shutdown Modules to trigger shutdown or other automatic actions for protected servers.

Network Management Cards are compatible with the "Enterprise Power Management" supervision system and with the MGE Office Protection Systems network protection system.

[Network Shutdown Module](#)

[Enterprise Power Manager](#)

[Management-Pac 2](#)

1.2.2 Direct sending of E-mail

When a UPS event occurs, the Network Management Card can directly notify up to 4 intranet or extranet addresses by e-mail. (see E-mail Notification and [E-mail message settings](#))

1.2.3 Sending text messages (SMS)

The card offers the possibility of redirecting UPS alarms to an e-mail server. The format of these e-mails is compatible with mobile telephone e-mail/SMS transfer systems proposed by ISPs. The format to be used depends on the service provider.

For example, sms.0660256585@votre-login.activmail.net (text messages).

1.2.4 Compatibility with the Network Management Systems (NMS) – Trap sending

The Network Management Cards are compatible with the major Network Management Systems (IBM Tivoli, CA Unicenter, HP Insight Manager). The Management-Pac 2 offering includes the necessary SNMP plug-ins to allow an easy integration in the NMS. Events are notified by SNMP trap.

NMS can subscribe on page "[Notified Applications](#)"

The trap list is given in the [appendix](#).

1.2.5 Environment Sensor (option)

The [Environment Sensor](#) (66846) solution comprises a box to be connected to the Card Settings port of the Network Management Cards.

Environment Sensor enables measurement of temperature and humidity around the UPS, consideration of external alarms via 2 dry contacts and notification of alarms according to pre-programmed thresholds. (see [Environmen Status](#) and [Environment Configuration](#))

1.3 Technical data

1.3.1 Hardware characteristics

Dimensions

Dimensions (L x l x H)	132 x 66 x 42 mm
Weight (gr)	70 g

Storage

Storage temperature	-10 °C to 70 °C
---------------------	-----------------

Ambient conditions

Operating temperature	0 °C to 40 °C
Ambient humidity	90 % RH max without condensation
ROHS	100 % compatible

1.3.2 EMC Compatibility

When correctly installed and used in accordance with the manufacturer's instructions, the Network Management Card complies with the following standards:

Safety for ATI: IEC/EN 60950-1 2002

EMC: EN 61000-6-2 (2002), EN 61000-6-3 (2002). IEC/EN 62040-2 (2002).

As per European directives:

Low voltage: 73/23/EEC and 93/68/EEC

EMC: 89/336/EEC and 93/68/EEC.

1.3.3 Configuration

The user can configure the card with one of the following means:

Web browser

Local serial link (network parameters)

BOOTP/DHCP (network parameters).

1.3.4 Administration

Up to 50 workstations protected by Network Shutdown Modules - Central or local configuration.

Up to 5 browsers connected at the same time (3 in SSL).

- ▶ Minimum recommended browser versions: Internet Explorer 6.x / 7.0, Mozilla Firefox 1.5 / 2.0
- E-mail sending configurable according to UPS alarms and transmission of a periodical report.
- Control of UPS on/off switching via the HTML interface.
- Adjustment and control of PowerShare outlets via the HTML interface, sequential starting of the installation and optimisation of backup time by shutting down non-priority systems.
- Automatic data and time adjustment via NTP server.
- Protection by encrypted password.
- Protection by secure SSL connection.
- Saving of logs in the non-volatile memory.
- Languages available: English/French/Spanish/German/Italian.
- On-line help in English available for each page.
- Card firmware updated via the network.

1.3.5 Network

- ▶ Fast ETHERNET 10/100 Mbits compatibility with auto-negotiation on the RJ45 outlet.

1.3.5.1 List of ports used

▶ BootP, DHCP	UDP 68, 67
▶ HTML	TCP 80
▶ SSL	TCP 443
▶ NSM in connected mode	TCP 5000
▶ SMTP	25
▶ NTP	123
▶ SNMP V1	161
▶ TRAP SNMP	162

1.3.6 Environment sensor

- ▶ Temperature measurement from 0 to 70 °C with +/- 1 °C accuracy.
- ▶ Measurement of humidity from 0 to 100 % with +/- 6 % accuracy.
- ▶ Min / max time-stamped function for temperature and humidity.
- ▶ Choice of temperature readings in Celsius or Fahrenheit.
- ▶ High and low thresholds, hysteresis and offset adjustable via Web interface.
- ▶ Possibility of notification of status changes by e-mail, SMS or SNMP trap.
- ▶ Position detection of 2 dry contacts (maximum sensor/contact distance: 20 m).
- ▶ Name and status of each configurable contact.

- ▶ Recording of events and measurements in the card log
- ▶ Possibility of shutting down the installation in the event of a threshold being exceeded or on opening / closure of a dry contact
- ▶ Connection to the card with straight CAT5 RJ45 network cables (maximum card/sensor distance: 20 m)
- ▶ Hot installation

1.3.7 MIB (Management Information Base)

- ▶ Compatible with MIB MGE Office Protection Systems V1.7
The list of objects managed can be found in the [appendix](#)

1.3.8 Default parameters

Function	Parameter	Default value	Possible value
Network	IP address	172.17.16.16	Network IP address
	Subnet mask	255.255.0.0	Network IP address
	Gateway Address	0.0.0.0	Network IP address
	BOOTP/DHCP	Enabled	Active / Deactivated
	Firmware Upload	Enabled	Active / Deactivated
	SMTP server	smtpserver	49 characters maximum
System	UPS Contact	Computer Room Manager	49 characters maximum
	UPS Location	Computer Room	31 characters maximum
	History log interval (sec.)	60	10 to 99999 sec.
	Environment log interval (sec.)	300	10 to 99999 sec.
	Default Language	English	English / French / Spanish / German / Italian
Manager table		empty	50 maximum
Access control	User name	MGEUPS	10 characters maximum
	Password	MGEUPS	10 characters maximum
	Community name read	public	49 characters maximum
	Trap port	161	Non configurable
Date and time	Date and time adjustment	Accept automatic update from NSM or EPM	Synchronise with an NTP server Accept automatic update from NSM or EPM Synchronise manually
	NTP server	ntpserver	49 characters maximum
Serial link	Speed	9600 baud	Non configurable
	Data bits	8	Non configurable
	Stop bits	1	Non configurable
	Parity	without	Non configurable
	Flow control	without	Non configurable

2 Installation

2.1 Unpacking and check on contents

The installation kit contents:

- ▶ A Network Management Card (66102)
- ▶ A serial communication cable for configuration (34003918)
- ▶ Installation manual (34003905)

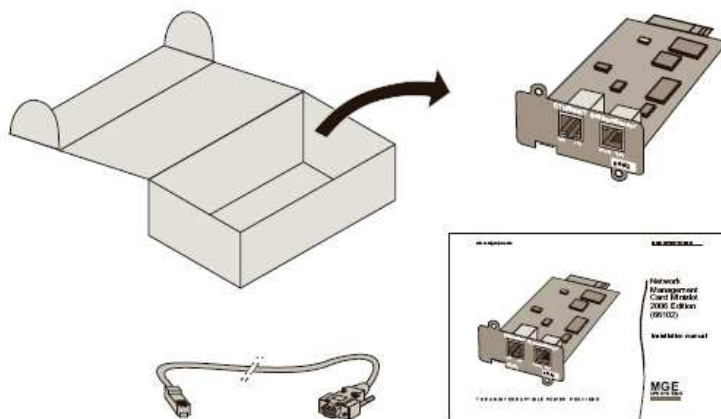

2.2 Indications

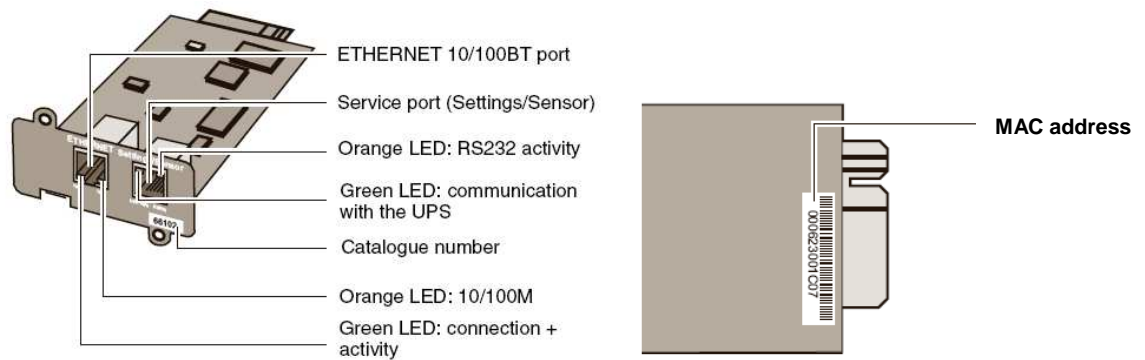

Ethernet port

LED	Colour	Activity	Description
ACT	Green	<ul style="list-style-type: none"> ▶ Off ▶ On ▶ Flashing 	<ul style="list-style-type: none"> ▶ Card not connected to the network. ▶ Card connected to the network but without activity ▶ Port is active in receiving / transmission
100M	Orange	<ul style="list-style-type: none"> ▶ Off ▶ On 	<ul style="list-style-type: none"> ▶ Port operating at 10Mbits/s. ▶ Port operating at 100Mbits/s.

Service port

LED	Colour	Activity	Description
UPS Data	Green	<ul style="list-style-type: none"> ▶ Off ▶ On ▶ Flashing 	<ul style="list-style-type: none"> ▶ Card startup in progress. ▶ Communication with UPS in progress ▶ Normal operation. Communication with the UPS is operational
RS232	Orange	<ul style="list-style-type: none"> ▶ Off ▶ On ▶ Flashing 	<ul style="list-style-type: none"> ▶ Configuration menu is active ▶ Normal operation. Configuration menu is deactivated ▶ Communication with the Environment Sensor (option).

2.3 Installation in the UPS

The Network Management Card (66102) can be "hot" installed in all UPSs of the MGE Office Protection Systems range equipped with a Minislot without having to shut it down.

- ▶ Remove the protective plastic cover from the Minislot
- ▶ Note the card's MAC address prior to insertion
- ▶ Insert and tighten the card's retaining screws
- ▶ Connect the ETHERNET cable
- ▶ Wait 2 min. the card is completely operational when the green UPS Data LED flashes continuously

2.4 Sensor installation (option)

The Environment sensor is available as an option on the Network Management Card and is available from MGE Office Protection Systems (reference 66846).

The sensor allows remote monitoring of the UPS's environment through regular measurements: temperature, humidity, status of two external contacts. It also enables notification of alarms (e-mail, trap SNMP) according to pre-programmed thresholds.

It is connected to the Service port (Settings/Sensor) directly on the Network Management Card with a standard Ethernet cable (20 meters maximum).

Recognition is automatic. Supervision and configuration are performed via a menu that can be accessed directly from the home page.

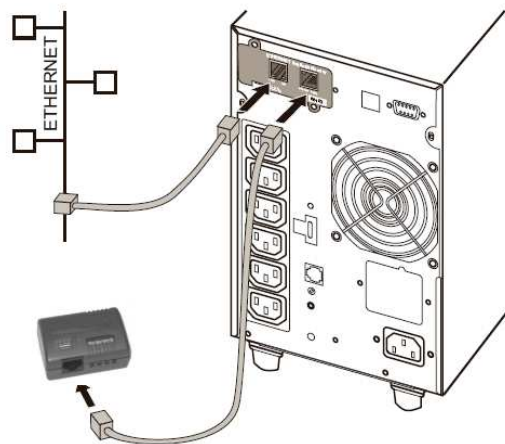

3 Configuration

3.1 Configure IP parameters

Once the card has started:

Connect one end of the cable (34003918) to the Service port.

If the environment sensor was previously connected, the card must be restarted in order to access the configuration menu.

Connect the other end of the cable to the COM port (IOIOI) of a PC.

Launch a HyperTerminal™ type emulator with the following configuration:

Speed: 9600

Data bits: 8

Parity: none

Stop bits: 1

Flow control: none

"Locally reproduce the characters entered" option: deactivated.

Enter MGEUPS or mgeups. The main menu is displayed:

```
-----  
MGE UPS SYSTEMS  
NETWORK MANAGEMENT CARD  
-----  
1 : Reset  
2 : Network configuration  
3 : Set Login Password to Default  
4 : Return to Default Configuration  
0 : Exit  
-----
```

3.1.1 Your network is equipped with a DHCP server

The card is configured by default with this service activated.

The card automatically collects IP parameters.

To know the IP parameters, type 2, the next menu is displayed:

```
-----  
Network settings  
-----  
1 : Read Network settings  
2 : Modify Network settings  
3 : Set Ethernet speed  
0 : Exit  
-----
```

Then type 1. The menu is displayed:

```
Network configuration :  
MAC address : 00:06:23:00:1F:8F  
Mode : Static IP  
IP address : 172.17.21.94  
Subnet mask : 255.255.248.0  
Gateway : 172.17.17.1
```

Note the IP address.

To exit, enter 0 then 0. The card is operational.

Note: As long as the card is not connected to the network, it continuously attempts to make connection. Once the connection has been established, the operational mode presented in the table above becomes effective.

3.1.2 Your network is not equipped with a DHCP server

In the main menu enter 2, then 2 again. The menu is displayed:

Follow the instructions and enter the static IP parameters.

At the end of the menu, wait for the "Done" message to be displayed indicating that the IP parameters have been saved.

```
-----  
Network settings  
-----  
1 : Read Network settings  
2 : Modify Network settings  
3 : Set Ethernet speed  
0 : Exit  
-----  
For each of the following questions, you can press <Return> to select the value  
shown in braces, or you can enter a new value.  
Should this target obtain IP settings from the network?[N] N  
Static IP address [172.17.21.94]? 172.17.21.21  
Static IP address is 172.17.21.21  
Subnet Mask IP address [255.255.248.0]? 255.255.255.0  
Subnet Mask IP address is 255.255.255.0  
Gateway address IP address [172.17.17.1]? 172.17.17.1  
Gateway address IP address is 172.17.17.1  
Wait during your new configuration is saved ...  
Reset the card to take into account the new configuration.
```

Return to the main menu and enter 1 then 2.

The card restarts with the new IP parameters.

3.2 Test after configuration

To check that the Network Management Card is operational after installation and configuration.

From a station connected to the same subnet as the card, open a web browser and enter the IP address of the card in the address field

Check the display of the [home page](#).

4 Supervision and administration by browser

- ▶ On a computer equipped with a Web browser (Internet Explorer, FireFox or Netscape recommended), enter the address initialised previously in the Installation chapter (e.g. <http://172.17.16.16>.)
The "UPS properties" home page is displayed.

4.1 Optimising the performance of your browser

- ▶ To view status changes on the UPS in real time, the browser must be configured so that it automatically refreshes all the objects on the current page.
Example on IE 6: Tools / Internet Options / General / Parameters menu, tick Every time this page is visited and validate.

4.2 UPS

4.2.1 UPS properties page

This page is automatically refreshed every 10 seconds.

From this page, access to the main UPS information is available thanks to the combo box (see screen copy below).

The different choices are the following ones:

“UPS Status”: (chosen by default) this page gives instant access to the essential information about your UPS.

“UPS Alarms”: to view the list of current alarms.

“UPS Modules”: (available on modular UPS) to view general information on each modules.

“About your UPS”: provides information on the UPS and the card, in particular, the model range and software version.

These different pages are detailed in the following chapters.

MGE
Office Protection Systems

Network Management Card

The screenshot shows the MGE Network Management Card interface. On the left is a sidebar with three main sections: **UPS** (containing links for UPS Properties, UPS Control, Weekly Schedule, and Shutdown Parameters), **Logs and Notification** (containing Measurements, Event Log, System Log, and Email Notification), and **Settings** (containing Network, System, Notified Applications, Access Control, Time, and Firmware Upload). The main content area is titled "UPS Properties" and features a "Help" button in the top right. It displays a diagram of a "Pulsar MX Frame 16U Computer room" UPS system. Below the diagram is a "UPS Status" dropdown menu. The status information is presented in a table:

Active sources :	1 UPS + 3 UPS redundant
Power source :	AC Power
Output load level :	0%
Output :	<ul style="list-style-type: none"> Master : On Group1 : On Group2 : On
Battery	
Battery load level :	100% Charging
Remaining backup time :	5 h 49 mn 29 s
Battery status :	OK

At the bottom of the page, it states "Last update : 2008/02/21 10:56:46".

4.2.1.1 "UPS" zone: general information on the UPS.



Indication of the picture and generic name of the UPS range

Computer room: Customised name of your system.

You can change this name on the ["System"](#) page.

UPS status icon :

The various icons showing the status of the UPS are:

	Normal operation
	Alarm present. This icon links directly to the alarm page.
	Loss of communication with the UPS

Animated synoptic: An animated synoptic gives a global overview of the UPS current operating mode.

This synoptic is available on On-Line and Line-interactive UPS.

The synoptic drawing depends on the UPS topology. The different drawings are described in the table below.

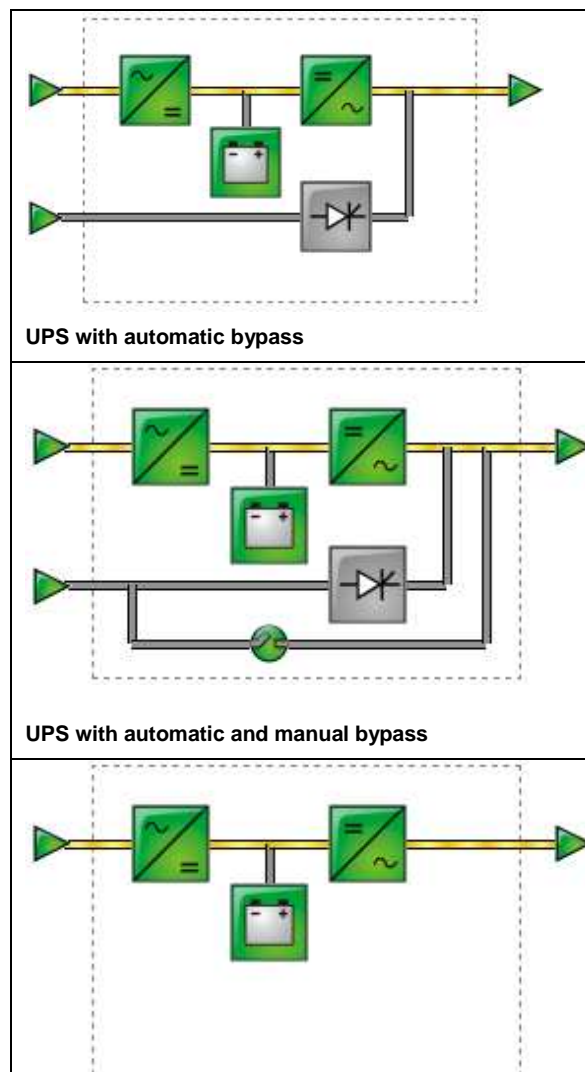



UPS without automatic bypass



Note: In case of loss of communication with the UPS, all the elements of the synoptic are grey.

The various elements of the synoptic are the following ones:



▶ AC Normal Input :

	In tolerances
	Out of tolerances



▶ AC Normal Flow :

	AC to DC converter powered by AC Normal
	AC to DC converter not powered by AC Normal



▶ AC to DC Converter:

	Powered
	Not powered
	Internal failure



▶ **Battery :**

	Remaining capacity > 50%
	Remaining capacity < 50%
	Battery to be checked (battery test result)



▶ **Battery Output Flow :**

	DC to AC converter powered by battery
	DC to AC converter not powered by battery



▶ **DC to AC Converter Input flow :**

	Energy flow present
	No energy flow



▶ **DC to AC Converter :**

	Powered
	Not powered
	Internal failure



▶ **DC to AC Converter Output :**

	Energy flow present
	No energy flow

▶ **AC Bypass Input :**

	In tolerances
	Out of tolerances



▶ AC Automatic Bypass Flow :

	Energy flow present
	No energy flow



▶ AC Automatic Bypass Status :

	Powered
	Not powered
	Internal failure



▶ AC Manual Bypass Flow :

	Energy flow present
	No energy flow



▶ AC Manual Bypass Status :

	Open
	Closed

▶ AC Output Flow :

	Energy flow present
	No energy flow

▶ AC Output :

	Load protected
	Load not protected

- ▶ **UPS measurements :**
- ▶ **Boxes showing measurements appear when synoptic elements are hovered by the pointer. See example below.**

MGE
Office Protection Systems

Network Management Card

UPS

- ▶ **UPS Properties**
- ▶ UPS Control
- ▶ Weekly Schedule
- ▶ Shutdown Parameters

Logs and Notification

- ▶ Measurements
- ▶ Event Log
- ▶ System Log
- ▶ Email Notification

Settings

- ▶ Network
- ▶ System
- ▶ Notified Applications
- ▶ Access Control
- ▶ Time
- ▶ Firmware Upload

UPS Properties Help



Pulsar MX Frame 16U
Computer room



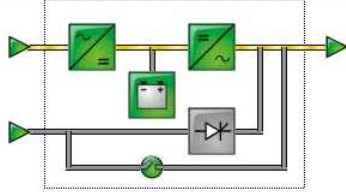

AC Output

Voltage	231 V
Current	1.1 A
Frequency	49.9 Hz
<hr/>	
Load level	0 %
Apparent Power	0.0 kVA
Active Power	0.0 kW

UPS Status: ▼

Active sources :	1 UPS + 3 UPS redundant
Power source :	AC Power
Output load level :	<div style="width: 100%; height: 10px; background-color: gray;"></div> 0%
Output :	<ul style="list-style-type: none"> ● Master : On ● Group1 : On ● Group2 : On

Battery

Battery load level :	<div style="width: 100%; height: 10px; background-color: green;"></div> 100% Charging
Remaining backup time :	5 h 49 mn 29 s
Battery status :	OK



Last update : 2008/02/21 10:57:48

These measurements are available for AC to DC converter, Battery, DC to AC converter and automatic bypass.
The measurements available in these boxes depend on the UPS range.

4.2.1.2 "UPS status" zone: Essential information

- ▶ "Active sources": (available on parallel or modular UPS)
 - x UPS + y UPS redundant : x indicates the minimal number of UPS necessary to power the load, y indicates the number of UPS in redundancy.
 - An alarm can be generated if the number of UPS in redundancy is less than a configurable threshold. See UPS modules section.
- ▶ "Power source": indicates whether the power comes from the utility or from the UPS battery
- ▶ "Output load level": indicates the power percentage used at UPS output
- ▶ "Output": indicates if the different UPS outputs are protected.
- ▶ "Master": indicates if the UPS main output is protected
- ▶ "Group1 and Group2": indicates if the controlled outlets (if available) are powered.

The various icons showing the status of the UPS outputs are:

 (green outlet)	Outlet powered
 (red outlet)	Outlet not powered or not protected

Battery Information :

- ▶ "Battery load level": remaining battery charge (in percent).
The information is completed with the two following labels:
- ▶ "Charging" : if the utility power is present and the battery charge is in progress
- ▶ "Discharging": if the UPS operates on battery.
- ▶ "Fault": if the battery is faulty.
- ▶ "Remaining backup time": Estimation of the battery's maximum backup time remaining before UPS shutdown
- ▶ "Battery status": Result of the last automatic battery test carried out by the UPS

Possible values are:

- OK: the test was completed correctly
- NOK: the battery needs to be checked
- Deactivated: the automatic battery test is not validated on the UPS

4.2.1.3 Viewing the modules

- Click on "UPS Modules" scroll list to view the information about the UPS modules.

MGE
Office Protection Systems

Network Management Card

UPS Properties Help

UPS

- UPS Properties
- UPS Control
- Weekly Schedule
- Shutdown Parameters

Logs and Notification

- Measurements
- Event Log
- System Log
- Email Notification

Settings

- Network
- System
- Notified Applications
- Access Control
- Time
- Firmware Upload

UPS Modules

Active sources : **1 UPS + 3 UPS redundant**

Minimum redundant UPS modules to trigger alarm :

Module Nr	Status	Technical Level / Firmware Revision	Serial Nr	Output load level	Battery load level
1		209	1V7G47011	0%	100%
2		209	1V7G15032	0%	100%
3		209	1V7G43020	0%	100%
4		209	1V7G47017	0%	100%

- Active sources:**

x UPS + y UPS redundant : x indicates the minimal number of UPS necessary to power the load,
y indicates the number of UPS in redundancy.

The addition of these 2 values is the total number of available UPS.

- The "Minimum redundant UPS modules to trigger alarm can be configured from this page. The button Save makes the card setting the parameter into the UPS. A warning message informs the user about the consequences of this parameters modification.

The redundancy lost can generate Email notification (if set in the email notification page) and SNMP trap. It can also be used by NSM for server protection criteria.

- The Module Nr gives the location of the module in the UPS.

- ▶ The Status can take the next forms:



or



when the module is working properly with no alarm.



when the module has at least one alarm (level Warning) active.



when the module has at least one alarm (level Critical) active.



when the module has a communication fault.

When the module is working properly with no alarms, the icon is not reactive, otherwise it is reactive and clicking on it makes the page Alarm Table appear.

- ▶ "Output load level": Value of the percentage of load at module output
- ▶ "Battery load level": Percentage of charge available in the battery module

4.2.1.4 Viewing the alarms

Click on "Alarm Table" scroll list to view the list of current alarms. The table of managed alarms is included in the [appendix](#).

The level of the alarms appears like below:

-  Critical
-  Warning
-  Unknown

▶ Alarm table for standard UPS



Network Management Card

UPS

- ▶ UPS Properties
- ▶ UPS Control
- ▶ Weekly Schedule
- ▶ Shutdown Parameters

Logs and Notification

- ▶ Measurements
- ▶ Event Log
- ▶ System Log
- ▶ Email Notification

Settings

- ▶ Network
- ▶ System
- ▶ Notified Applications
- ▶ Access Control
- ▶ Time
- ▶ Firmware Upload

Environment

- ▶ Status
- ▶ Settings
- ▶ Log





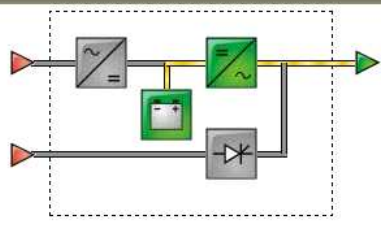

UPS Properties Help



 **Pulsar 1000 RT2U**
Computer Room



UPS Alarms

	Alarm Time	Alarm Description	Severity
UPS	1970/01/01 00:00:42	End of Warranty soon. Contact MGE at www.mgeups.com/lcm	
	2008/02/22 14:47:10	Normal AC frequency out of tolerance	
	2008/02/22 14:47:10	Normal AC voltage out of tolerance	
	2008/02/22 14:47:11	Bypass AC frequency out of tolerance	
	2008/02/22 14:47:11	Bypass AC voltage out of tolerance	
	2008/02/22 14:47:12	Normal AC NOK	
	2008/02/22 14:47:12	UPS on battery	

Alarm table for modular UPS



Network Management Card

UPS

- UPS Properties
- UPS Control
- Weekly Schedule
- Shutdown Parameters

Logs and Notification

- Measurements
- Event Log
- System Log
- Email Notification

Settings

- Network
- System
- Notified Applications
- Access Control
- Time
- Firmware Upload

UPS Properties Help

Pulsar MX Frame 16U
TEST upload / Pulsar MX Frame



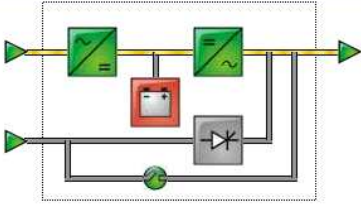

UPS Alarms

	Alarm Time	Alarm Description	Severity
UPS	1970/01/01 00:00:00	Perte de redondance	⚠
	2008/02/21 10:45:38	Défaut batterie	❗
Module 4	2008/02/21 10:45:30	Pas de batterie	❗
	2008/02/21 10:45:36	Défaut batterie	❗

4.2.1.5 Viewing the "About your UPS" window

Click on "About your UPS" scroll list to view the information about the UPS and the card.

MGE
Office Protection Systems

Network Management Card

UPS Properties Help

UPS

- UPS Properties
- UPS Control
- Weekly Schedule
- Shutdown Parameters

Logs and Notification

- Measurements
- Event Log
- System Log
- Email Notification

Settings

- Network
- System
- Notified Applications
- Access Control
- Time
- Firmware Upload

Environment

- Status
- Settings
- Log

UPS Properties

 **Pulsar 1000 RT2U**
Computer Room

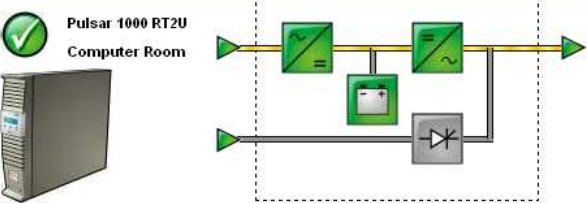

About your UPS

UPS Name :	Pulsar 1000 RT2U
UPS Serial Number :	1Y2F4
UPS Technical Level :	unknown
System Technical Level / Firmware Revision :	00

Network Management Card

Card Firmware revision :	DA
Card Commercial Reference :	66102
Card Technical Level :	01
Card Revision :	CA
Card Serial Number :	49HG20042
Card Ethernet Mac Address :	00:06:23:00:1E:1B
Card Ethernet Speed :	100 MBit

4.2.2 On-line help

On-line contextual help in English is available at the top of each page by clicking on the Help link, which is always located on the top right corner. The navigation menu of the on-line help is identical to that of the card's pages.

The Help page always opens a new window.

The screenshot shows the MGE Network Management Card interface. On the left is a navigation menu with categories: UPS, Logs and Notification, Settings, and Environment. The main content area is titled 'UPS Properties Help' and contains several paragraphs of text explaining the page's content, including the alarm icon, electric diagram, and status information.

MGE
Office Protection Systems

Network Management Card

UPS

- UPS Properties
- UPS Control
- Weekly Schedule
- Shutdown Parameters

Logs and Notification

- Measurements
- Event Log
- System Log
- Email Notification

Settings

- Network
- System
- Notified Applications
- Access Control
- Time
- Firmware upload

Environment

- Status
- Settings
- Log

UPS Properties Help

This is the page by default, displaying the fundamentals status of the UPS.

At the top of the page, the UPS is identified : image, name and location.

The alarm icon above the UPS image shows if an alarm is active when it is red, click on it to see the current alarm page. When there is no alarm the green icon is displayed.

The electric diagram of the UPS is displayed showing the electrical flow which powers the load and also the main parts of the UPS.

The electric diagram is not available for Line Interactive UPS.

The second part of the page is refreshing every 10 seconds and contains informations depending of the selection in the combo box :

UPS Status selects the main status of the UPS :

Active sources shows the current use of a modular UPS, the notation x UPS + y UPS is meaning : x is the number of modules necessary to power the load, y is the number of redundant modules.

Power source shows where the power comes from.

Output load level shows the load level.

Output shows the status of all UPS outputs.

4.2.3 UPS control

Click on the "UPS Control" section in the menu

The parameters of this menu can only be modified after entering the "Login" and "Password". The following screen is proposed automatically:



The default login and password are: MGEUPS

Each field accepts up to 10 characters max.

After the login and password are entered, they remain active for 5 minutes.

If the browser is closed, they will have to be re-entered.

An error in either field results in systematic rejection of the requested action (save, page access, card reboot...). After three unsuccessful attempts, the browser must be rebooted.

These two fields do not travel "decoded" on the IT network. They are encrypted with an MD5 type algorithm, ensuring total confidentiality.

In the event of [password loss](#), the user can return to the default values via the maintenance menu.

UPS configuration may prevent the shutdown and restart commands from being properly run. Read the UPS user manual for more information.



MGE
Office Protection Systems

Network Management Card

UPS

- ▶ UPS Properties
- ▶ UPS Control
- ▶ Weekly Schedule
- ▶ Shutdown Parameters

Logs and Notification

- ▶ Measurements
- ▶ Event Log
- ▶ System Log
- ▶ Email Notification

Settings

- ▶ Network
- ▶ System
- ▶ Notified Applications
- ▶ Access Control
- ▶ Time
- ▶ Firmware Upload

Environment

- ▶ Status
- ▶ Settings
- ▶ Log

UPS Control
Help

Pulsar 1000 RT2U
Computer Room

Output	Status	Control	Off Delay	Toggle Duration	On Delay
Master	● On	Safe power down & reboot		0 sec	
Group1	● On	None	0 sec	0 sec	0 sec
Group2	● On	None	0 sec	0 sec	0 sec

This page enables triggering of [startup and shutdown sequences](#) for the UPS main output and controlled outlets.

- ▶ The status of each output is displayed by a symbol associated with the Off label (red symbol) or On (green symbol).
- ▶ The shutdown sequences take into account the time required for the registered servers to shut down without losing data ([see shutdown parameters](#)).
- ▶ The main outlet has priority over the controlled outlets. Shutdown of the main outlet causes the controlled outlets to shut down. Controlled outlets can only be started if the master outlet is on.

The Check column proposes six different commands, and a command is only actually started after clicking on 'Execute':

"Safe power down": A sequence to switch off output power is launched immediately. The systems supplied are shut down correctly while the shutdown sequence is running, then the output is cut.

"Safe power down & reboot": A sequence to switch off then restore output power is launched immediately. The powered systems are shut down correctly during the shutdown sequence, then the output is switched off. Finally, the restart sequence is launched at the end of the time delay specified in the "Toggle duration" parameter. The output status is updated.

"Immediate On": A sequence to switch on output power is launched immediately. The output is re-powered and the systems supplied start up correctly.

"Delayed, safe power down": This is the same switch off sequence as for the "Safe power down" command, but postponed by the number of seconds programmed in the "Off Delay" parameter.

"Delayed, safe power down & reboot": This is the same switch off then on sequence as for the "Safe power down & reboot" command, but postponed by the number of seconds programmed in the "Off Delay" parameter.

"Delayed On": This is the same switch on sequence as for the "Immediate On" command, but postponed by the number of seconds programmed in the "On Delay" parameter.

The Save button saves the Off Delay, Toggle duration and On Delay parameters on the card.

Security: The administrator must click on Save and enter his/her login/password to save modifications or run commands. The default login and password by default are: MGEUPS

4.2.4 UPS weekly schedule programming

Click on the "Weekly schedule" section of the menu.

MGE
Office Protection Systems

Network Management Card

Weekly Schedule Help

Pulsar 1000 RT2U Computer Room

Day	Shutoff Time	Restart Time
Sunday	-	22:00
Monday	20:00	06:30
Tuesday	-	-
Wednesday	-	-
Thursday	-	-
Friday	-	-
Saturday	05:30	-

UPS

- UPS Properties
- UPS Control
- Weekly Schedule
- Shutdown Parameters

Logs and Notification

- Measurements
- Event Log
- System Log
- Email Notification

Settings

- Network
- System
- Notified Applications
- Access Control
- Time
- Firmware Upload

Environment

- Status
- Settings
- Log

UPS configuration may prevent the shutdown and restart commands from being properly run. Read the UPS user manual for more information.

The weekly schedule enables the administrator to optimise power consumption or program a reboot of the protected equipment at a set time.

In a shutdown sequence, the Network Shutdown Modules connected to the card are informed and ensure that each machine is shut down correctly before the UPS output is switched off. Up to 7 UPS shutdown sequences can be programmed in one week, with a minimum shutdown delay of 30 minutes.

The On / Off sequences are valid only if the card's time has been properly set.

Security: The administrator clicks on "Save" and enters his/her login / password to save any edits. The login and password by default are: MGEUPS.

4.2.5 Shutdown parameters

This page enables viewing and configuration of UPS operating parameters in battery mode and for power restoration.

Click on the "Shutdown parameters" section in the menu to see the list of parameters.



Office Protection Systems

Network Management Card

UPS

- ▶ UPS Properties
- ▶ UPS Control
- ▶ Weekly Schedule
- ▶ Shutdown Parameters

Logs and Notification

- ▶ Measurements
- ▶ Event Log
- ▶ System Log
- ▶ Email Notification

Settings



- ▶ Network
- ▶ System
- ▶ Notified Applications
- ▶ Access Control
- ▶ Time
- ▶ Firmware Upload

Environment

- ▶ Status
- ▶ Settings
- ▶ Log

Shutdown Parameters
Help

Pulsar 1000 RT2U
Computer Room

Output	On battery	System Shutdown	Restart
<div style="text-align: center;">  <input type="text" value="Master"/> </div>	<p>Shutdown</p> <p>if Remaining time under: <input type="text" value="180"/> sec</p> <p>if Capacity under: <input type="text" value="20"/> %</p> <p><input type="checkbox"/> after: <input type="text" value="30"/> min</p>	<p>Shutdown duration: <input type="text" value="120"/> sec</p> <p style="text-align: center;">See also additional Shutdown configuration on Environment Settings</p>	<p>If Capacity exceeds: <input type="text" value="16"/> %</p>
<div style="text-align: center;">  <input type="text" value="Group1"/> </div>	<p>Switch Off</p> <p>after: <input type="text" value="963"/> sec</p> <p>if Capacity under: <input type="text" value="34"/> %</p>	<p>Shutdown duration: <input type="text" value="120"/> sec</p>	<p>Switch On</p> <p>after: <input type="text" value="4"/> sec</p>
<div style="text-align: center;">  <input type="text" value="Group2"/> </div>	<p>Switch Off</p> <p>after: <input type="text" value="584"/> sec</p> <p>if Capacity under: <input type="text" value="28"/> %</p>	<p>Shutdown duration: <input type="text" value="120"/> sec</p>	<p>Switch On</p> <p>after: <input type="text" value="7"/> sec</p>

Show advanced parameters

Save modified settings:

Export settings to file:

Import settings from file:

When you tick the Show advanced parameters option, extra parameters are displayed. These parameters enable, in particular, adjustment of certain thresholds related to the percentage of remaining battery charge level.

The Output column enables each outlet to be named (maximum 20 characters).

Note

As priority is given to the main outlet, the card cannot supply the controlled outlets when main outlet power is off.

For the main outlet ("Master" by default)

The first shutdown criteria initiates the restart of the [shutdown sequence](#).

- ▶ If remaining time is under (0 to 99999 seconds, 180 by default) is the minimum remaining backup time from which the shutdown sequence is launched.
- ▶ If battery capacity is under (0 to 100%); this value cannot be less than that of the UPS and is the minimum remaining battery capacity level from which the shutdown sequence is launched.
- ▶ Shutdown after (0 to 99999 minutes, not validated by default) is the operating time in minutes left for users after a switch to backup before starting the shutdown sequence.
- ▶ Shutdown duration (120 seconds by default) is the time required for complete shutdown of systems when a switch to backup time is long enough to trigger the shutdown sequences. It is calculated automatically at the maximum of Shutdown duration of subscribed clients but can be modified in the Advanced mode.
- ▶ If battery capacity exceeds Minimum battery level to reach before restarting the UPS after utility restoration

Important: Certain UPSs do not support this option

For the controlled outlets ("group 1 or group 2" by default)

The page enables programming of operation time and level in backup mode to manage outlet load shedding in the event of electric power failure:

- ▶ Switch Off after (from 0 to 99999, 65535 by default) defines the time during which the outlet is supplied starting from the moment of utility failure. Caution, this time includes the outlet shutdown duration.
- ▶ Switch Off if battery capacity under (0 by default) is an extra condition for outlet shutdown that can trigger the shutdown sequence before the shutdown duration runs out.
- ▶ Shutdown duration is the time required for complete shutdown of the systems supplied by the outlet when an outlet shutdown sequence is launched.
It is calculated automatically using the maximum shutdown durations of notified applications on the outlets.
- ▶ Switch On after (from 0 to 99999, default 65535) is the period between main output startup and startup of the relevant programmable outlet, therefore outlet startup can be delayed in relation to the main output.

Important: Certain UPSs do not support this option

Export settings to file: Enables exportation ("Download" button) and saving of card configuration information.

Import settings from file: Enables selection of a configuration file ("Browse" button) and uploading ("Upload" button) of card configuration information

Security: The administrator has to click on Save and enter his/her login/password to save any modifications. The login and password by default are: MGEUPS

4.2.6 Measurements

Click on "*Measurements*" in the menu

- ▶ The next window shows the measurements for a mono phases UPS.

MGE
Office Protection Systems

Network Management Card

UPS

- ▶ UPS Properties
- ▶ UPS Control
- ▶ Weekly Schedule
- ▶ Shutdown Parameters

Logs and Notification

- ▶ **Measurements**
- ▶ Event Log
- ▶ System Log
- ▶ Email Notification

Settings

- ▶ Network
- ▶ System
- ▶ Notified Applications
- ▶ Access Control
- ▶ Time
- ▶ Firmware Upload

Measurements Help

Pulsar 1000 RT2U Computer Room

Date	Time	AC Normal		AC Output				Battery	
		Voltage	Frequency	Voltage	Frequency	Power (kVA)	Load level (%)	Capacity (%)	Remaining time (mn)
2008/02/19	16:37:54	228	50.0	229	50.0	0.0	0	100	138
2008/02/19	16:36:52	227	50.0	229	49.0	0.0	0	100	138
2008/02/19	16:35:51	227	50.0	230	49.0	0.0	0	100	138
2008/02/19	16:34:49	228	50.0	229	50.0	0.0	0	100	138
2008/02/19	16:33:47	228	50.0	230	50.0	0.0	0	100	138
2008/02/19	16:32:46	228	50.0	230	49.0	0.0	0	100	138
2008/02/19	16:31:44	228	50.0	230	49.0	0.0	0	100	138
2008/02/19	16:30:42	228	49.0	230	49.0	0.0	0	100	138
2008/02/19	16:29:41	227	50.0	231	50.0	0.0	0	100	138

The following measurements are saved and time-stamped (env. 430):

- ▶ "AC Normal : Voltage": Value of the utility voltage supplying the UPS
- ▶ "AC Normal : Frequency": Value of the utility frequency supplying the UPS
- ▶ "AC Output : Voltage": Value of the output voltage of your UPS
- ▶ "AC Output : Frequency": Value of the output frequency of your UPS
- ▶ "AC Output : Power (kVA)": Value of the output power of your UPS
- ▶ "AC Output : Load level (%)": Value of the percentage of load at UPS output
- ▶ "Battery : Capacity (%)": Percentage of charge available in the battery
- ▶ "Battery : Remaining time (mn)": Estimation of the remaining backup time
- ▶ The save frequency of these values is defined in the "[System](#)" page (60 seconds by default). Approximately 435 time-stamps are stored permanently on the card. The oldest time-stamps are automatically deleted.
- ▶ "Save Log" enables all saved values to be opened or saved in CSV format. (compatible with Excel type spreadsheets)
- ▶ "Clear Log" enables deletion of all records. Enter the login/password to validate this action.

4.2.7 Event log

- Click on "Event Log". in the menu

MGE
Office Protection Systems

Network Management Card

UPS

- UPS Properties
- UPS Control
- Weekly Schedule
- Shutdown Parameters

Logs and Notification

- Measurements
- Event Log**
- System Log
- Email Notification

Settings

- Network
- System
- Notified Applications
- Access Control
- Time

Event Log Help

Pulsar 1000 RT2U Computer Room

Date	Time	Event Description
2008/02/21	15:29:13	Bypass AC voltage out of tolerance
2008/02/21	15:29:13	Bypass AC frequency out of tolerance
2008/02/21	15:29:13	Normal AC voltage out of tolerance
2008/02/21	15:29:13	Normal AC frequency out of tolerance
2008/02/21	15:29:12	Outlet group 2 shutdown in 7 mn 44 s
2008/02/21	15:29:12	Outlet group 1 shutdown in 14 mn 03 s
2008/02/21	15:29:12	System shutdown in 1 h 50 mn 07 s
2008/02/21	15:29:11	UPS on battery
2008/02/21	15:29:11	Normal AC NOK

- "Save log" enables all saved values to be opened or saved in CSV format. (compatible with Excel type spreadsheets)
- "Clear log" enables deletion of all records. The administrator must enter his/her login / password to validate this action.

The card can save 435 events. The table of managed alarms is included in the [appendix](#).

4.2.8 System log

- Click on "System log". in the menu

MGE
Office Protection Systems

Network Management Card

UPS

- UPS Properties
- UPS Control
- Weekly Schedule
- Shutdown Parameters

Logs and Notification

- Measurements
- Event Log
- System Log**
- Email Notification

System Log Help

Pulsar 1000 RT2U Computer Room

Date	Time	Event Description
2008/02/22	10:16:51	Environment sensor : Communication restored
1970/01/01	00:00:43	Time synchronized by NSM or EPM with 2008/02/22 09:43:05 [172.17.131.185]
1970/01/01	00:00:18	Network Management Card startup
2008/02/22	09:40:39	Firmware upgraded

- "Save log" enables all saved values to be opened or saved in CSV format. (compatible with Excel type spreadsheets)
- "Clear log" enables deletion of all records. The administrator must enter his/her login / password to validate this action.

The card can save 435 events. The table of managed alarms is included in the [appendix](#).

4.3 Notification

4.3.1 Email Notification

The card offers the possibility of redirecting UPS alarms to an e-mail server. The format of these e-mails is compatible with mobile telephone transfer systems using text messages (SMS).



Network Management Card

Email Notification
Help

Pulsar 1000 RT2U
Computer Room

UPS

- UPS Properties
- UPS Control
- Weekly Schedule
- Shutdown Parameters

Logs and Notification

- Measurements
- Event Log
- System Log
- Email Notification

Settings

- Network
- System
- Notified Applications
- Access Control
- Time
- Firmware Upload

Environment

- Status
- Settings
- Log

Recipient list

recipient1@domain.com
 recipient2@domain.com
 recipient3@domain.com
 recipient4@domain.com

Recipient :

Attached files :

- Measurements
- Event Log
- System Log
- Environment Log

Periodic report : Every day(s) at:

day of next report:

[Email Message Settings](#)

Configure SMTP Server on

[Network Settings](#)

Notified events for the selected Recipient

Battery operation

- UPS on battery
- UPS on normal AC
- UPS Off sequence in progress
- Low battery

UPS alarms

- Battery fault
- Battery OK
- UPS overload
- UPS returns to normal load
- UPS fault
- UPS OK
- UPS communication failed
- UPS communication restored
- Charger fault
- Output on by-pass
- Return from by-pass

Software alarms

- Firmware upgrade
- Environment sensor communication failed

Environment alarms

Configured on [Environment Settings](#)

- Environment sensor notification

Export settings to file :

Import settings from file :

▶ **Recipient List:**

On the left side of this page, up to four recipients can be configured to receive e-mails from the card. Each addressee has its own trigger events, selected from the right side of the page, for which an e-mail is sent. The card's log indicates e-mail transmission errors.

Each recipient is configured with the following parameters:

- ▶ Recipient: (Field is limited to 49 characters) this is the e-mail address of the person or department to receive the e-mail.
The default value is recipientx@domain.com
- ▶ Attached files: The files selected (Measurements, Event log, System log, Environment measurements) are enclosed with each e-mail sent. The files are sent in CSV format
- ▶ Periodic report: In addition to the e-mails sent when events occur, a periodic e-mail containing the 3 log files can be sent to the recipient every x days at the time specified by the user.
To configure the first transmission, specify the day, time and frequency of the next transmission in the "next report" box. After this date, the page will show the date and time of the next transmission.
Data are sent in CSV format.

▶ **Save:** Saves any modifications.

- ▶ **Test** enables an e-mail to be sent to the recipient immediately. This is one way of checking e-mail transmission, particularly access to the SMTP server configured in "Network" settings. A transmission report is added to the system log.

The event label in the subject and text of the message is replaced with a test label.

If the user makes any modifications to the page, they must be saved before using the "Test" function.

▶ **Notified events:**

- ▶ The right side of the page shows the events that can be notified.

By default, only the main events of battery operation and a few UPS alarms are accessible. All the events appear if the Show/Hide Events option is actuated.

By default, two events are selected for notification. The user can modify this pre-selection by ticking other events or can, on the contrary, restore the initial configuration by clicking Set Default.

▶ **Email Message Settings:** access to the message configuration page

- ▶ **Network Settings:** enables the name of the SMTP server to be entered. [See page](#)

- ▶ **Export settings to file:** Enables exportation ("Download" button) and saving of card parameterisation information.

- ▶ **Import settings from file:** Enables selection of configuration file ("Browse" button) and uploading ("Upload" button) of card configuration information.

- ▶ **Security:** The administrator has to click on Save and enter his/her login/password to save any modifications. The default

login and password are: MGEUPS

4.3.2 E-mail Message Settings

This page enables customisation of the content of the messages received by recipients of e-mails sent by the card. Customisation is common to the four recipients that can be notified (see [E-mail notification](#)).

Sender

(59 characters maximum) identifies the source of the message. The default value is *ups@domain.com*.

This field is free. However, depending on the type of SMTP server configuration, it is possible that the server checks that the domain name contained in the Sender address exists, and even that the user in the Sender address belongs to this domain.

Subject

enables the user to specify the subject of the e-mail to be sent. By entering some free text and selecting from several optional fields, if desired, the message subject is built:

- UPS name recalls the name of the UPS; it may or may not be selected.
- UPS location recalls the geographic location of the UPS (see System Settings); it may or may not be selected.
- Event message identifies the event generating the e-mail; it may or may not be selected.

Message text is a free zone.

The body of the e-mail sent is composed of:

- Message text, which is free text.
- The date and time of the event, as saved in the log.
- URL of the card, enabling a direct link with the card to be established.
- Attachments, as configured for the e-mail recipients .- duplication of the subject, as configured.



```
MGE UPS SYSTEMS - Test message
Date : 2007/08/07 Time : 13:58:57
URL : http://172.17.18.129
```



```
Type here your own text LogUpsMesure.csv
```

4.4 Configuration

The parameters of this menu can only be modified after entering the "Login" and "Password". The following screen is proposed automatically:



The default login and password are: **MGEUPS**

Each field accepts up to 10 characters max.

After the login and password are entered, they remain active for 5 minutes.

If the browser is closed, they will have to be re-entered.

An error in either field results in systematic rejection of the requested action (save, page access, card reboot...). After three unsuccessful attempts, the browser must be rebooted.

These two fields do not travel "decoded" on the IT network. They are encrypted with an MD5 type algorithm, ensuring total confidentiality.

In the event of [password loss](#), the user can return to the default values via the maintenance menu.

4.4.1 Network settings

Click on "Network" in the menu.

This menu enables the administrator to configure the network parameters of the card and authorisation of the remote upgrade of the embedded system.

The screenshot shows the MGE Network Management Card interface. The left sidebar contains a navigation menu with sections: UPS (UPS Properties, UPS Control, Weekly Schedule, Shutdown Parameters), Logs and Notification (Measurements, Event Log, System Log, Email Notification), Settings (Network, System, Notified Applications, Access Control, Time, Firmware Upload), and Environment (Status, Settings, Log). The main content area is titled "Network Settings" and "Pulsar 1000 RT2U". It features a table of configuration fields:

Field	Value
IP address :	172.17.131.109
Subnet Mask :	255.255.255.0
Gateway Address :	172.17.131.1
Hostname :	ups27
Domain Name :	ups.domain.com
BootP/DHCP :	Enabled
Firmware Upload :	Enabled
Primary DNS Server :	172.17.17.94
Secondary DNS Server :	172.17.131.20
SMTP Server (for Email Notification) :	smtpserver

Below the table are three buttons: "Save" (labeled "Save modified settings :"), "Download" (labeled "Export settings to file :"), and "Upload" (labeled "Import settings from file :").

- ▶ **IP Address:** The IP address of the card (e.g.: 172.17.22.252).
- ▶ **Subnet Mask:** The mask of the sub-network of your network (e.g.: 255.255.255.0).
- ▶ **Gateway Address:** Indicate the IP address of the gateway to access the stations located outside the card's subnet (e.g.: 172.17.17.1).
- ▶ **Hostname** must be suited to the card. This is the first part of the fully qualified domain name, used by the DNS. As the card does not support NetBIOS protocol, the hostname will only be sent to DNS if the DHCP server sends it the hostname with the new IP address. This mechanism is described in the update of the DNS protocol [RFC 2136](#)
- ▶ **Domain Name** is the domain to which the card belongs. This is the part of the fully qualified domain name that follows the hostname and is used by the DNS. The default value of the two parameters comprising the fully qualified domain name: ups.domain.com
- ▶ **BOOTP/DHCP:** Authorises (choose "Enabled") configuration of network parameters with your BootP/DHCP server when the card is booted.

Mode of card operation with server: After each startup, the card makes 5 attempts to recover the network

parameters. If no response is received from the server, the card boots with the last saved parameters from the previous start. These parameters are those shown on the page.

The default value for this parameter is "Enable"

Note 1:

If the hostname is not used, the IP address supplied by the DHCP server must be fixed to maintain connection with the clients installed on the stations to be protected.

Note 2:

During the first connection, if the DHCP query is not successful, the NMC starts with the following IP configuration:

IP address:172.17.16.16

Subnet mask: 255.255.255.0

Gateway Address: 0.0.0.0

- ▶ **Firmware Upload: Authorise** (chose "Enabled") remote updating of the card's embedded software.
The default value for this parameter is "Enabled".
- ▶ **Primary DNS Server:** contains the IP address of the main DNS server ensuring conversion of the domain name to IP address.
- ▶ **Secondary DNS Server:** contains the IP address of the secondary DNS server ensuring conversion of the domain name to IP address if the primary DNS server is not available.
- ▶ **SMTP Server:** contains the name or IP address of the local server with which the card connects to send e-mails.
It may be filled in either as host + domain name (DNS resolution), or directly with the IP address.
The default value is smtpserver. The card uses the standard port (25) for sending e-mails.

Export settings to file: Enables exportation ("Download" button) and saving of card configuration information.

Import settings from file: Enables selection of a configuration file ("Browse" button) and uploading ("Upload" button) of card configuration information.

Important note:

The card must be rebooted after any changes to these parameters.. [See "System" page](#)

Security: The administrator has to click on Save and enter his/her login/password to save any modifications.

4.4.2 System

Click on "System" in the menu.

This menu enables the customisation of the information on the [UPS properties](#) pages.

MGE
Office Protection Systems

Network Management Card

System Settings Help

Pulsar 1000 RT2U Computer Room

UPS Contact :	<input type="text" value="Computer Room Manager"/>
UPS Location :	<input type="text" value="Computer Room"/>
Default Language :	<input type="text" value="English"/>
History log interval (sec):	<input type="text" value="60"/>
Environment log interval (sec):	<input type="text" value="300"/>

Save modified settings :

Export settings to file :

Import settings from file :

Keep TCP/IP parameters

- ▶ **UPS Contact:** This text field is limited to 49 characters. Enter the name of the person responsible for UPS administration at IT network level and/or electrical maintenance. This field does not appear on any other Web page. By default, its value is "Computer Room Manager".
- ▶ **UPS Location:** Enter a description (limited to 49 characters) of the location of the UPS in your installation (e.g. Computer room E1-C066). This text is displayed in the home page. By default, its value is "Computer Room".
- ▶ **Default Language:** Enables initialisation of the browser language at card connection. Choice of one of the available languages: English, French, German, Spanish, Italian changes the language of the html interface pages (reboot the browser after modification).
- ▶ **History log interval:** [from 5 to 99999 sec., 60 by default]. Measurement save period.
- ▶ **Environment log interval:** [from 60 to 99999 sec., 300 by default]. Temperature and humidity measurement save period. **Reset Communication** button: performs a remote reboot of the card without modifying the configuration. This action is compulsory for consideration of any changes made on the "Network Settings" page. Security of this operation is ensured by requesting Login and Password.

- ▶ **Factory Reset button:** enables restoration of the default configuration of all the card's parameters. TCP/IP parameters: IP address, subnet mask, gateway and BootP/DHCP value are maintained if the "Keep TCP/IP parameters" option is selected. Security of this operation is ensured by requesting Login and Password. The default login and password are: MGEUPS
- ▶ **Export settings to file:** Enables exportation ("Download" button) and saving of card configuration information.
- ▶ **Import settings from file:** Enables selection of a configuration file ("Browse" button) and uploading ("Upload" button) of card configuration information.

4.4.3 Notified Applications

Click on "*Notified Applications*" in the menu.

Security: The administrator has to enter his/her login/password in order to view this information.

This menu enables:

- ▶ The addition of the supervision stations receiving traps and configuration of the trap type.
- ▶ To list all the Notified Applications and the main parameters.
- ▶ To test the operation of notified applications
- ▶ by simulating power loss
- ▶ by sending a real shutdown sequence.

MGE
Office Protection Systems

Network Management Card

UPS

- ▶ UPS Properties
- ▶ UPS Control
- ▶ Weekly Schedule
- ▶ Shutdown Parameters

Logs and Notification

- ▶ Measurements
- ▶ Event Log
- ▶ System Log
- ▶ Email Notification

Settings

- ▶ Network
- ▶ System
- ▶ **Notified Applications**
- ▶ Access Control
- ▶ Time
- ▶ Firmware Upload

Environment

- ▶ Status
- ▶ Settings
- ▶ Log

Notified Applications Help

Pulsar 1000 RT2U Computer Room

All	Nr	Hostname or IP Address	Application Name	Output	Configuration	Shutdown duration(sec)	Shutdown after (min)	Connected
<input type="checkbox"/>	1	WXFRAPCMGE0424D	Shutdown Module V3.10	Master	CENTRALIZED	120		Yes
<input type="checkbox"/>	2	WXFRAPCMGE0396L	Shutdown Module V3.10	Master	CENTRALIZED	120		

Select the applications to be removed.

Select the applications to be tested.

Select the Network-Management-System to be modified.

Up to 100 destinations can be managed by the card :

- ▶ 35 in TCP connected mode or
- ▶ 100 in UDP not connected mode or
- ▶ mixed mode: 20 connected and 50 not connected.

Important note: It is not necessary to add the Network Shutdown Modules protecting your servers in this list. These modules subscribe and unsubscribe themselves automatically.

Select an entry in the list to modify the values in the edit zone at the bottom of the page. The table displays the following information:

- ▶ **The All button:** Allows the following information to be displayed.
- ▶ **Nr** is the index where the application is stored into the table.
- ▶ **Hostname or Address IP:** By priority, the hostname of the computer is displayed when the IP address can be converted into a hostname by a DNS server or if the application has been entered as a hostname.

- ▶ **Output:** number of the UPS output from which the client is powered.
- ▶ **Configuration:** shows where the parameters of the Network Shutdown Module come from: Local (coming from the application) or Central (coming from the card).
The [Central shutdown configuration](#) is available by clicking on the Configuration link.
- ▶ **Shutdown duration:** the shutdown duration necessary to properly shutdown the computer.
- ▶ **Shutdown after:** the time available to the user from the power failure until the launch of the shutoff sequence of the UPS and equipment This parameter is optional.

Many actions are available on this page:

- ▶ **Remove:** Depending on the kind of application, the selected ones will definitively disappear from the table as SNMP applications, or they will disappear and automatically re-subscribe as Network Shutdown Module applications.
- ▶ **Utility failure Test:** Two alarms, 'Utility failure' and 'Utility restored' spaced 60 seconds apart, will be sent to the applications selected, making sure that the applications can be reached over the network.
- ▶ **Shutdown Test:** This test simulates a UPS on battery operation. It enables an easy check to see if the server protection works correctly.
 - No intervention on the UPS is required.
- The applications selected will process the simultaneous alarms and perform an actual shutdown sequence.

WARNING!

- This test will generate a REAL shutdown sequence of the selected servers on which the Network Shutdown Module application is running.

- ▶ **Add NMS:** allows an SNMP trap receiver to be added such as a Network Management System.
- ▶ **Modify NMS:** allows an SNMP trap receiver to be modified.

Both buttons open a new window where it is possible to enter the Application name, the Hostname or IP Address, the Trap community and the severity.

The screenshot displays the MGE Network Management Card interface. On the left, there is a navigation menu with sections: UPS (UPS Properties, UPS Control, Weekly Schedule, Shutdown Parameters), Logs and Notification (Measurements, Event Log, System Log, Email Notification), and Settings (Network, System, Notified Applications, Access Control, Time, Firmware Upload). The main content area is titled 'Network-Management-System' and shows configuration for 'Pulsar 1000 RT2U'. The configuration fields are as follows:

Nr :	3
Application Name :	HP ov
Hostname or IP address :	PCname.domain.com
Protocol :	SNMP V1
Trap Community :	public
Severity :	1 - Warning

At the bottom of the configuration area, there are 'Cancel' and 'Save' buttons.

The default severity value is 1 – Warning

4.4.4 Central shutdown configuration

Click on "Notified Applications" in the menu, then "Configuration".

MGE
Office Protection Systems

Network Management Card

UPS

- UPS Properties
- UPS Control
- Weekly Schedule
- Shutdown Parameters

Logs and Notification

- Measurements
- Event Log
- System Log
- Email Notification

Settings

- Network
- System
- Notified Applications
- Access Control
- Time
- Firmware Upload

Central shutdown configuration

Pulsar 1000 RT2U

This configuration will be used by the Network-Shutdown-Modules, on next connection.

Shutdown Parameters

Shutdown after: 30 min Shutdown duration: 120 sec

Broadcast

- Administrators
- Users

Save

This page is used to define either the "shutdown" or the "notification" settings used by the Network Shutdown Modules that connect to Network Management Card. These settings are used by the Network Shutdown Modules if they are in central-configuration mode or if their configuration is not valid.

- ▶ **Shutdown duration:** the shutdown duration necessary to properly shutdown the computer.
- ▶ **Shutdown after:** the time available to the user from the power failure until the launch of the shutoff sequence of the UPS and equipment. This parameter is optional. Uncheck the box if you wish not to use this parameter.
- ▶ **Broadcast :** Sends network notifications to the Administrators and Users groups on events declared in the server hosting the NSM

If you wish to set up a new configuration for the Network Shutdown Modules already set to "central-configuration mode", proceed as indicated below:

- ▶ Change the Network Shutdown Module parameters in the "Notified Applications" page.
- ▶ Click the "Save" button.
- ▶ In this page, select the NSMs for which you want to apply the new configuration.
- ▶ Press the "Remove" button.
- ▶ The NSMs selected will disconnect then reconnect and use the new configuration.

4.4.5 Access control

Click on "Access Control" in the menu.

To access this page, the login and password are systematically requested if they have not already been entered.

This menu enables configuration of the different parameters enabling secure access to the card via a browser or SNMP.

MGE
Office Protection Systems

Network Management Card

Access Control Help

Pulsar 1000 RT2U Computer Room

Enter New Manager Login :

Enter New Password :

Confirm New Password :

Current Community Read-Only is : public

Change Community Read-Only :

Security mode :

Authentication for configuration

Full authentication

SSL and full authentication

Save modified settings :

UPS

- UPS Properties
- UPS Control
- Weekly Schedule
- Shutdown Parameters

Logs and Notification

- Measurements
- Event Log
- System Log
- Email Notification

Settings

- Network
- System
- Notified Applications
- Access Control
- Time
- Firmware Upload

Environment

- Status
- Settings
- Log

- ▶ **Login:** This text field is limited to 10 characters - Enables secure access and modification of pages. Default value "MGEUPS"
- ▶ **Change / Confirm password:** This text field is limited to 10 characters - Enables secure access to Configuration menu pages. Default value "MGEUPS"
- ▶ **Current Community Read name:** Indicates the SNMP community name used for read operations
- ▶ **Change Community Read-Only:** This text field is limited to 49 characters - Enables the SNMP community name used for read operations to be changed
- ▶ **Security mode:** manages the various authentication methods for page access
- ▶ **Authentication for configuration:** Only the configuration pages are protected by login / password
- ▶ **Full authentication:** All pages are protected by login / password
- ▶ **SSL and full authentication:** All pages are protected by login / password and are only accessible in SSL

- ▶ **SSL Access:** When selected, access to the Web interface is made in secure mode (https).

Connections with Network Shutdown Modules stay in standard mode (secure TCP)

SSL Security Implementation:

SSL	→ version 3.0
TLS	→ version 1.0
Method	→ TLS_RSA_WITH_512_MD5
Auth	→ RSA
Key Exchange	→ RSA
Encryption	→ RC4_512
Digest	→ MD5

Changes take effect after a card reboot

4.4.6 Date and time

Click on "*Date and Time*" in the menu.

This menu enables initialisation of the date and time of the card in three different ways.

The date format is always of year/month/day type

MGE
Office Protection Systems

Network Management Card

UPS

- UPS Properties
- UPS Control
- Weekly Schedule
- Shutdown Parameters

Logs and Notification

- Measurements
- Event Log
- System Log
- Email Notification

Settings

- Network
- System
- Notified Applications
- Access Control
- Time**
- Firmware Upload

Environment

- Status
- Settings
- Log

Setting time Help

Pulsar 1000 RT2U Computer Room

Current date and time

Date (yyyy/mm/dd): 2008/02/21
Time (hh:mm:ss): 16:27:22

Setting time

Set manually

Date (yyyy/mm/dd):
Time (hh:mm:ss):

Accept automatic update from NSM or EPM

Synchronize with NTP server

Hostname :
Time-Zone :

European Daylight Savings Time

Save modified settings :

- ▶ **Set manually:** Enables initialisation of the date and time of the card, with the values entered in the Date and Time fields. This update is made after clicking on the "Save" button.

Maximum drift is +/- 2 min./month

- ▶ **Accept automatic update from NSM or EPM:** Enables initialisation of the date and time of the card, with the values provide by the Network Shutdown Modules or the Enterprise Power Management.

- ▶ **Synchronize with NTP server:** Enables connection with a time server, either available on the company's internal network or on the Web. This server communicates GMT time. The IP address or hostname of the time server must be entered, and the time zone of your geographic area must then be selected from the list. Connection is made with the server and the date and time are set after clicking on the "Save" button. Time is updated every five hours, thus preventing any drift in the time. After two attempts, if the NTP server is not accessible, the card shifts to manual mode.

The card uses the NTP protocol (UDP 123 port). The "firewall" must be set to transmit queries outside the intranet. No error message is generated if the time server contact fails.

Note 1:

The even the card is used in a UPS supporting time-stamping, the card's time is automatically synchronized with that of the UPS.

Note 2:

After start-up, if the card is in manual mode or if no NTP server was reached, the card initializes at 01/01/1970

4.4.7 Firmware upload

Click on "*Firmware Upload*" in the menu.

This menu enables a new firmware version to be uploaded

The screenshot shows the MGE Network Management Card interface. On the left, there is a navigation menu with two main sections: **UPS** and **Logs and Notification**. The **UPS** section includes links for UPS Properties, UPS Control, Weekly Schedule, and Shutdown Parameters. The **Logs and Notification** section includes links for Measurements, Event Log, System Log, and Email Notification. The main content area is titled **Firmware Upload** and shows the device name **Pulsar 1000 RT2U** and the location **Computer Room**. Below this, there is a section labeled **Firmware to Upload :** with a text input field, a **Parcourir...** button, and an **Upload** button. A yellow warning box contains the text: **WARNING: This action takes a few minutes. Don't click on any button or item during this operation.**

To upload a new version of the card's firmware, select the file to be loaded using the "Browse..." button and click **Upload**.

Do not interrupt the operation before the card displays the following screen:

The screenshot shows the MGE Network Management Card interface after a successful firmware upload. The navigation menu and main content area are the same as in the previous screenshot. The **Firmware Upload** section now displays a green success message: **SUCCESS : Firmware was successfully written in FLASH. Restart in progress. Wait a few minutes and click on Refresh button.**

4.5 Environment Sensor (option)

The environment sensor (66846) is an option that enables temperature and humidity to be measured, and indication of the position of two external contacts. It is connected with a standard network cable to the Card Settings port of the Network Management Card.

The card automatically detects sensor presence. The main menu then displays an additional section "Environment" with the following elements:

- ▶ Status
- ▶ Configuration
- ▶ Log

Important note: To switch the serial port to the configuration mode, just disconnect the cable and [reset the card](#).

4.5.1 Characteristics

- ▶ Temperature measurement from 0 to 70 °C with +/- 1° C accuracy
- ▶ Measurement of humidity from 0 to 100% with +/- 6% accuracy
- ▶ Min / max time-stamped function for temperature and humidity
- ▶ Choice of temperature readings in Celsius or Fahrenheit
- ▶ High and low thresholds, hysteresis and offset adjustable via Web interface
- ▶ Possibility of notification of status changes by e-mail, SMS or SNMP trap
- ▶ Position detection of 2 dry contacts (maximum sensor/contact distance: 20 m)
- ▶ Name and status of each configurable contact
- ▶ Recording of events and measurements in the card log
- ▶ Possibility of shutting down the installation safely if one of the thresholds is exceeded or dry contact status change
- ▶ Connection to the Network Management Card by CAT5 straight RJ45 network cables (maximum card/sensor distance: 20m)

4.5.2 Environment Status

MGE
Office Protection Systems

Network Management Card

Environment Status Help

Pulsar 1000 RT2U Computer Room

Temperature

0 °C **22.9 °C** 70 °C

Min: 21.2 recorded on 2008/02/19 16:25:39
Max: 23.0 recorded on 2008/02/21 16:32:32

Reset Min/Max Calibrate Configure thresholds on Environment Settings

Humidity

0 % **28.6 %** 100 %

Min: 25.0 % recorded on 2008/02/19 16:25:39
Max: 29.8 % recorded on 2008/02/21 15:34:36

Reset Min/Max Calibrate Configure thresholds on Environment Settings

Input #1

1970/01/01 00:00:00 Input #1 open

Input #2

1970/01/01 00:00:00 Input #2 open

For both measurements, a graduated gauge proposes the following functions:

The cursor indicates the current value.

Two red zones to the left and right represent the high and low thresholds that can be set on the Environment Settings page.

When the measured value enters one of these zones, an alarm can be notified (see Notification parameter in the Environment Settings page).

Time-stamped minimum and maximum temperatures show the extreme values recorded since the last Reset Min/Max, a thin dotted line shows their positions on the gauge.

Min and Max can be forced at any time to the current value by clicking on the Reset Min/Max button.

Calibrate: The sensor is factory-calibrated, but the user can apply an offset to adjust the measurement.

Input #1 and Input #2 show the position of the two contacts acquired by the sensor.

The position is displayed with the parameters entered in the Environment Settings page.

The last status change of each contact is time-stamped.

The Internet browser updates this page every 10 seconds

4.5.3 Environment Settings



Network Management Card

UPS

- UPS Properties
- UPS Control
- Weekly Schedule
- Shutdown Parameters

Logs and Notification

- Measurements
- Event Log
- System Log
- Email Notification

Settings

- Network
- System
- Notified Applications
- Access Control
- Time
- Firmware Upload

Environment

- Status
- Settings
- Log

Environment Settings
Help

Pulsar 1000 RT2U
Computer Room

Sensor name:	Environment sensor	Notification	System Shutdown
Temperature	High threshold: <input type="text" value="40"/>	<input checked="" type="checkbox"/>	<input type="checkbox"/>
	<input type="text" value="°C"/> Low threshold: <input type="text" value="5"/>	<input type="checkbox"/>	<input type="checkbox"/>
	Hysteresis: <input type="text" value="2"/>		
Humidity	High threshold: <input type="text" value="90"/> %	<input type="checkbox"/>	<input type="checkbox"/>
	Low threshold: <input type="text" value="5"/> %	<input type="checkbox"/>	<input type="checkbox"/>
	Hysteresis: <input type="text" value="5"/> %		
Input #1:	<input type="text" value="Input #1"/> <input type="text" value="closed"/> when closed	<input type="checkbox"/>	<input type="checkbox"/>
	<input type="text" value=""/> <input type="text" value="open"/> when open	<input checked="" type="checkbox"/>	<input checked="" type="checkbox"/>
Input #2:	<input type="text" value="Input #2"/> <input type="text" value="closed"/> when closed	<input type="checkbox"/>	<input type="checkbox"/>
	<input type="text" value=""/> <input type="text" value="open"/> when open	<input type="checkbox"/>	<input type="checkbox"/>

Show advanced parameters

Save modified settings :

Export settings to file :

Import settings from file :

The environment sensor measures temperature, humidity and gives the status of the 2 contacts (used for door, alarms or generator unit).

The temperature and humidity thresholds can be adjusted and can trigger notification and correct shutdown of the protected system.

The Sensor name is the function name given to the sensor, usually it enables location of the sensor.

Temperature: Choose the temperature unit (°C or °F) from the selection box.

High threshold: If this value is exceeded, a notification is sent if this is validated. The default value is 40 °C / 104 °F.

Low threshold: If this value is exceeded, a notification is sent if this is validated. The default value is 5 °C / 41 °F .

Hysteresis must be set to prevent multiple notifications if temperature fluctuates around a threshold.

The default value is 2 °C / -3.6 °F.

The high alarm disappears when the value drops below the High threshold - Hysteresis value

The low alarm disappears when the value returns above the Low threshold + Hysteresis value

Humidity

High threshold: If this value is exceeded, a notification is sent if this is validated. The default value is 90%.

Low threshold: If this value is exceeded, a notification is sent if this is validated. The default value is 5%.

ENERGIZE YOUR ENTERPRISE

Network Management Card – User Manual

34003991EN/DA

Page 62/120

Hysteresis must be set to prevent multiple notifications if humidity fluctuates around a threshold. The default value is 5%.

The high alarm disappears when the value drops below the High threshold - Hysteresis value

The low alarm disappears when the value returns above the Low threshold + Hysteresis value

Input #1 and Input #2: Enter an identifier corresponding to the acquired contact (e.g.: rack door, air conditioning, generator unit, etc.). Max. length is 28 characters.

when closed and when open: are the names associated to the two contact positions. (e.g.: "open" and "closed" for a door, "On" and "Off" for a generator).

Each status change triggers a notification if enabled.

When the Notification box is enabled, the following functions are activated for each event selected:

- ▶ display in the [list of current alarms](#)
- ▶ Consideration in the [UPS log](#)
- ▶ SNMP trap generation
- ▶ notification by e-mail (if the Environment sensor notification option is enabled in the [e-mail notification](#) page)

The list of messages is given in the [appendix](#)

System shutdown can be triggered for each notification if this option is enabled. If notification is disabled, the Shutdown option cannot be used.

Export settings to file: Enables exportation ("Download" button) and saving of card configuration information.

Import settings from file: Enables selection of a configuration file ("Browse" button) and uploading ("Upload" button) of card configuration information.

Security: The user must be identified to access this page.

4.5.4 Log

MGE
Office Protection Systems

Network Management Card

UPS

- UPS Properties
- UPS Control
- Weekly Schedule
- Shutdown Parameters

Logs and Notification

- Measurements
- Event Log
- System Log
- Email Notification

Settings

- Network
- System
- Notified Applications
- Access Control
- Time
- Firmware Upload

Environment

- Status
- Settings
- Log

Environment Log Data Help

Pulsar 1000 RT2U Computer Room

Date	Time	Temperature (°C)	Humidity (%)
2008/02/21	17:09:42	22.9	28.7
2008/02/21	17:04:34	22.9	28.6
2008/02/21	16:59:25	22.9	28.6
2008/02/21	16:54:17	22.9	28.6
2008/02/21	16:49:08	23.0	28.6
2008/02/21	16:43:59	23.0	28.6
2008/02/21	16:38:51	23.0	28.6
2008/02/21	16:33:44	23.0	28.5
2008/02/21	16:28:34	23.0	28.5
2008/02/21	16:23:25	23.0	28.5
2008/02/21	16:13:00	23.0	28.5
2008/02/21	16:07:51	23.0	28.7
2008/02/21	16:02:43	22.9	28.8
2008/02/21	15:57:34	22.9	28.8
2008/02/21	15:52:25	22.8	28.9

The two environment sensor measurements: Temperature and Humidity are recorded at an interval defined by the Environment log interval in the [System settings](#) page.

By default, this period is 300 seconds.

Each measurement is dated and stored in the log of the UPS's communication card.

The size of log files is limited by a time indexing system.

The user can Save the log on his/her workstation at any time, in a CSV format file.

The user can also Clear the files contained in the card to reset the log.

5 Server protection

5.1 Set-up of the shutdown parameters

The Network Shutdown Module, on protected server boot, subscribes itself automatically to [notified applications](#) list and sends its essential data:

- ▶ IP Address or hostname of the server on which it is installed: So that the card can inform it of power events.
- ▶ Time required to shutdown the server (Shutdown Duration, configurable in the "Set-up" menu of each NSM): The card takes into account the longest shutdown time of all the Network Shutdown Modules subscribed (This is the Shutdown duration of the [Shutdown parameters](#)) page to manage UPS shutdowns without affecting any of Shutdown Modules connected.

During normal operation, the Network Shutdown Module periodically checks its connection with the card.

In case of a major power event, the card sends information to the Network Shutdown Module which reacts according to the situation. (shutdown order, programmed actions, messages to the administrator and to users via the network)

When the server shuts down, the Network Shutdown Module unsubscribes itself from the [notified applications](#).

5.1.1 Shutdown criteria managed by the Network Management Card

During an extended power failure, three criteria may cause the server shutdown procedure to be initiated. If several criteria are selected, (See page [Shutdown parameters](#)), the first criterion encountered will launch the shutdown procedure.

At the end of the shutdown procedure, when all servers have been shut down, the UPS may shut down to avoid unnecessary discharge of its batteries, depending on its configuration.

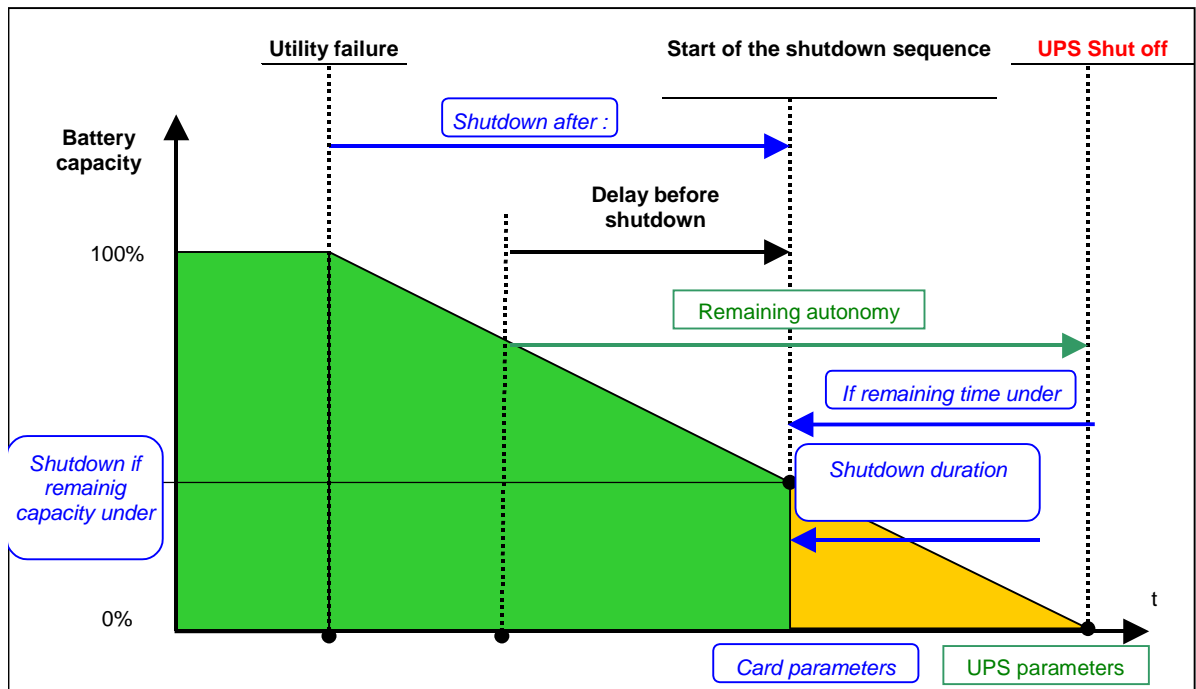

5.1.1.1 Backup time before initiating the shutdown procedure (Shutdown After – Shutdown Timer)

When the UPS switches to battery, the Network Management Card starts the Shutdown Timer countdown and launches the system shutdown procedure at the end of the countdown.

This value must be chosen so that users have time to complete their tasks and disconnect, without exceeding battery backup time.

Note 1:

The Network Shutdown Module can also manage its own Shutdown Timer (configurable in the Shutdown Module "set-up" menu of each Network Shutdown Module) launched when the UPS switches to battery.

Note that if this criterion is selected to initiate system shutdown, automatic system reboot when power is restored is not guaranteed (e.g. power restoration if only this system was shut down).

5.1.1.2 Initiating the shutdown procedure when the battery level is lower than: (If Capacity under)

When the card detects that the remaining backup time percentage is less than the configured level, the shutdown sequence is started.

By default, this value is set at 20%.

Note:

The UPS already manages an equivalent parameter for the end of backup pre-alarm.

The card does not accept values less than that programmed in the UPS.

Check the UPS documentation.

5.1.1.3 Shutdown when backup time is less than

When the Network Management Card detects that the percentage of backup time remaining is less than the value set, the shutdown sequence is started.

5.1.1.4 Shutdown duration

Duration (in seconds) required for the system protected by the Shutdown Modules to shut down.

The Network Shutdown Modules transmit their own "Shutdown duration" to the Network Management Card. Based on these values (maximum Shutdown duration of all subscribed customer systems) that the card will send to the delayed shutdown order to the UPS.

5.1.2 Controlled outlets

Certain UPS models are equipped with controlled outlets (generally 2) which are always dependant on the UPS's main outlet.

Shutdown of the main outlet systematically causes shutdown of the programmable outlets.

The following notations are used to identify these outlets:

- ▶ Main outlet: Main
- ▶ Controlled outlet 1 1
- ▶ Controlled outlet 2 2

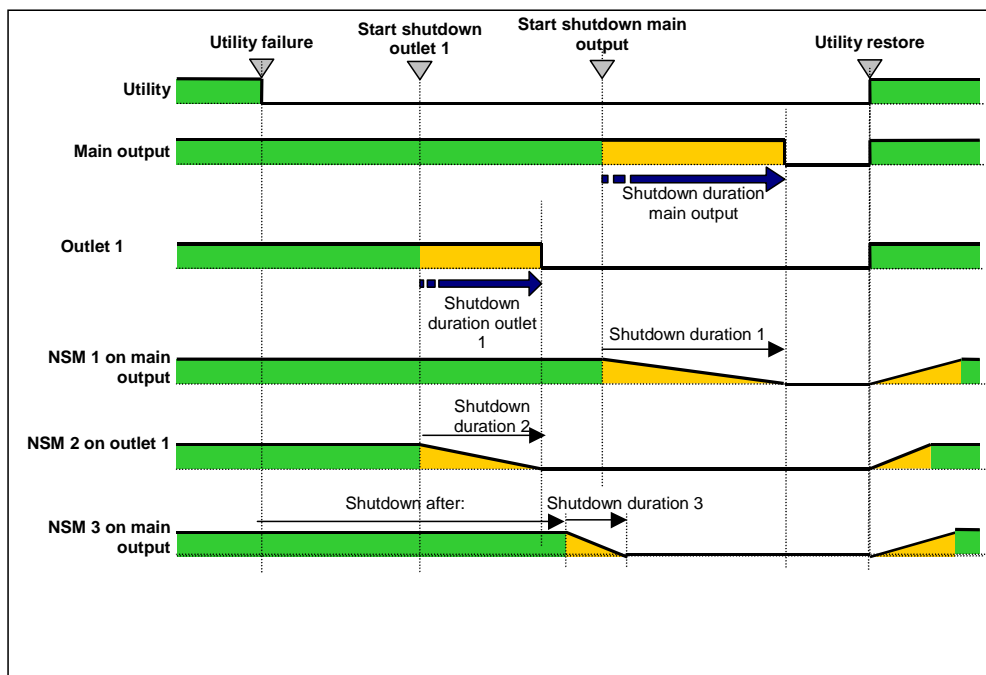

5.1.3 Protection of a server connected to a controlled outlet

Network Shutdown Modules (NSM) starting with version 3.0 are compatible with the controlled outlets.

After connecting the server electrically to one of the controlled outlets, the NSM must be informed of the outlet number to which it is connected.

Refer to the documentation of the NSM available on the internet site www.mgeops.com section "[Downloads – Software Download](#)".

5.1.3.1 Load shedding or sequential shutdown

It is possible to optimise backup time by shutting down non-priority equipment or sequencing the shutdown of several devices.

Two shutdown criteria are possible:

- ▶ Shutdown of outlets after a set battery back-up time (After)
- ▶ Shutdown of outlets at a given battery discharge level (if battery capacity under)

It is possible to specify values for both criteria. The first criterion reached will initiate server shutdown.

5.1.3.2 Sequential startup

It is possible to delay outlet power-on to reduce inrush currents on startup or to sequence the startup of several devices.

Controlled outlet startup after a given time is based on startup of the main outlet.

5.2 The different server and UPS shutdown sequences

5.2.1 Extended power outage, shutdown initiated by the Shutdown Timer (Shutdown after)

During battery backup time, the Shutdown Timer of the Network Management Card is reached: After a user-defined backup time period ([Shutdown parameters](#) page), the shutdown of all servers is initiated, followed by the UPS shutdown (depending on its configuration). The UPS restarts when utility power is restored (depending on its configuration)

Shutdown duration: Maximum value of shutdown times of the Network Shutdown Modules subscribed to the card. This value is updated each time a client subscribes/ unsubscribes.

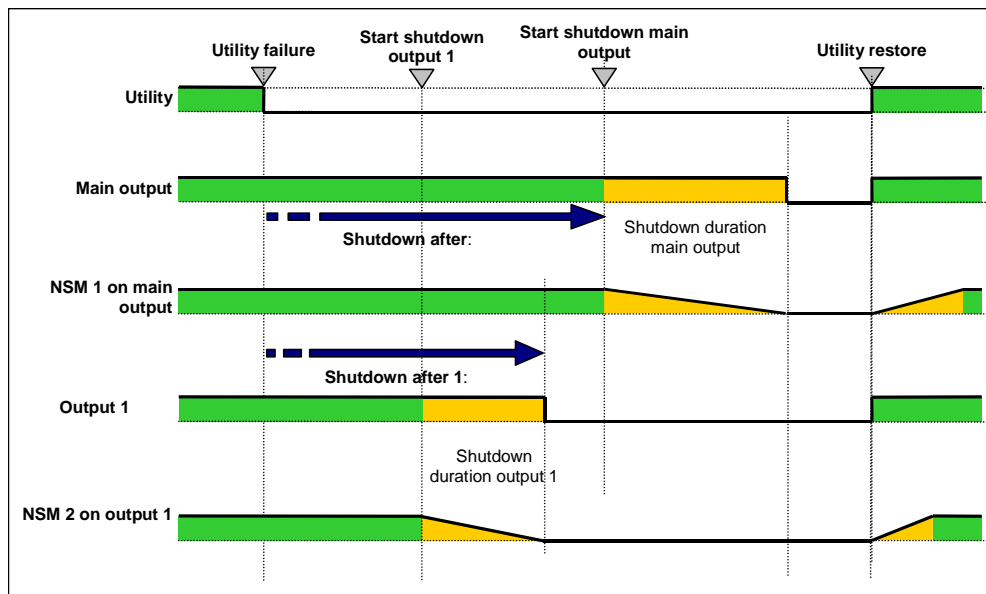

5.2.2 Extended power outage, shutdown initiated by the "Low battery power" message

When the "Low battery power" criterion is displayed, the UPS is shut off after taking into account the shutdown duration of the servers.

"Low battery power": The message appears if either of the two following criteria is checked:

- Low Battery Level
- Low Battery Delay

ENERGIZE YOUR ENTERPRISE

Network Management Card – User Manual

34003991EN/DA

Page 69/120

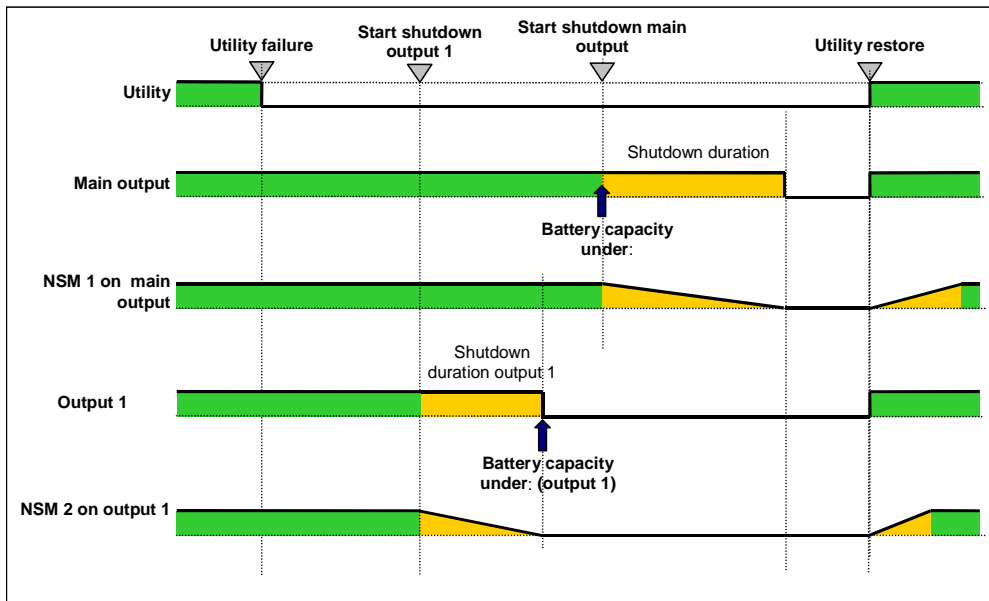

5.2.3 Case of power restoration before the end of the "shutdown duration" counter

If power is restored before the end of the Shutdown Duration, the UPS is shut off after the Shutdown Duration for a time equal to the forced reboot delay (10 seconds)

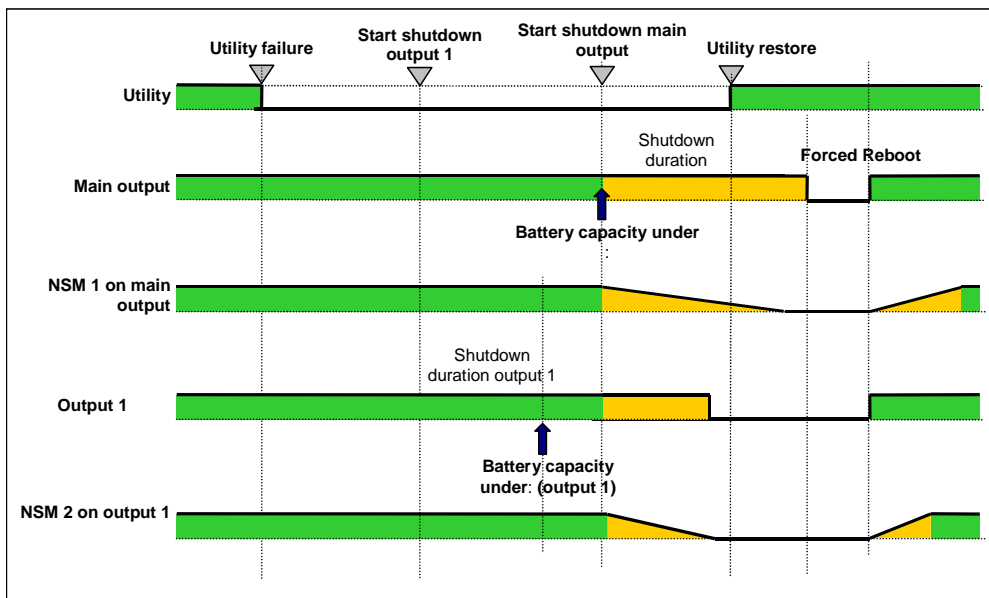

5.3 Shutdown management with 2 NMC boards

Certain UPS can have 2 NMC boards in order to:

- ▶ Increase the number of protected servers,
- ▶ Protect 2 groups of server connected to different networks physically separated.

5.3.1 Shutdown Duration

As described in the 5.1.1.4 paragraph, The Network Shutdown Modules transmit their own "Shutdown duration" to the Network Management Card. Based on these values (maximum Shutdown duration of all subscribed customer systems) that the card will send to the delayed shutdown order to the UPS.

If the UPS have two NMC cards, the maximum shutdown duration of the two groups of protected systems will be used for the delayed shutdown order.

Example: If the subscribed customers of the first NMC card have a maximum Shutdown duration of 60s and the ones of the second NMC card of 120s, the servers shutdown will be launched 120s before the UPS shutoff..

5.3.2 Settings

Set-up shutdown parameters to the same values on the 2 cards is highly recommended (for the main output and the controlled outlets).

If the settings are not the same, the first criteria reached on one the 2 cards will launch the secure shutdown of all servers

Please, note that in any case the shutdown of the protected servers will be executed safely.

6 Configuration via RS232

- ▶ Use the cord supplied with the card.

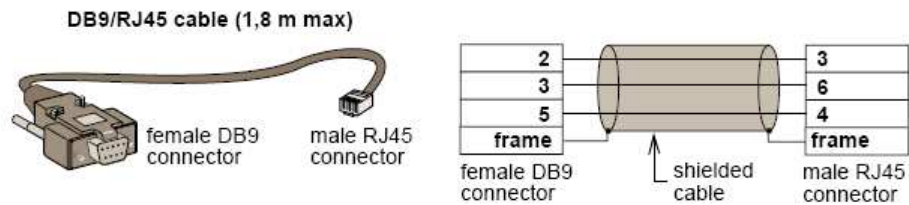

- ▶ Connect the card to a computer equipped with a hyperterminal type emulator. The serial link must be set at 9600 baud, 8 bits, no parity, 1 stop bit, and without flow control.
- ▶ Check that UPS power is on.
- ▶ Enter the MGEUPS or mgeups password (non modifiable).
- ▶ The menu is in English only.

MGE UPS SYSTEMS
NETWORK MANAGEMENT CARD

- 1 : Reset
 - 2 : Network configuration
 - 3 : Set Login Password to Default
 - 4 : Return to Default Configuration
 - 0 : Exit
-

6.1 Choice 1: Restart / Reset

Use this function to restart the card; two choices are possible

1 : Hardware Reset: Equivalent to a restart of the electrical power supply.

2 : Restart application: Restarts only the application part.

----- Reset ----- 1 : Hardware Reset 2 : Restart application 0 : Exit -----
--

6.2 Choice 2: Network Configuration

Use this function to access network settings.

----- Network settings ----- 1 : Read Network settings 2 : Modify Network settings 3 : Set Ethernet speed 0 : Exit -----
--

6.2.1 Choice 1: Read Network settings

Enables reading of the card's routine settings

Network configuration : MAC address : 00:06:23:00:1F:8F Mode : Static IP IP address : 172.17.18.129 Subnet mask : 255.255.248.0 Gateway : 172.17.17.1

6.2.2 Choice 2: Modify Network settings

Enables the modification of network parameters

For each of the following questions, you can press <Return> to select the value shown in braces, or you can enter a new value.
Should this target obtain IP settings from the network?[N]
Static IP address [172.17.18.129]?
Subnet Mask IP address [255.255.248.0]?
Gateway address IP address [172.17.17.1]?
Wait during your new configuration is saved ...
Reset the card to take into account the new configuration.

In DHCP mode, the card can receive the following parameters according to the DHCP server settings

- ▶ IP address
- ▶ Subnet Mask
- ▶ Gateway address
- ▶ Primary DNS server
- ▶ Secondary DNS server

The card must be [restarted](#) in order for the new parameters to be taken into account.

6.2.3 Choice 3: Set Ethernet speed

Enables the modification of the network speed

Set the Ethernet speed : [1 : Automatic, 2 : 10 MBit]
1
New Ethernet speed : Automatic
Wait during the new setting is saved ...
Reset the card to take into account the new configuration.

The card must be [restarted](#) in order for the new parameters to be taken into account.

6.3 Choice 3: Lost password / Set Login Password to Default

In the even the login or password is lost, choice 3 enables the return to the default password:

```
-----  
MGE UPS SYSTEMS  
NETWORK MANAGEMENT CARD  
-----  
1 : Reset  
2 : Network configuration  
3 : Set Login Password to Default  
4 : Return to Default Configuration  
0 : Exit  
-----  
Wait during Login Password return to default ...
```

Wait for the confirmation message.

```
Login Password are sucefully been set.
```

The card is now accessible via the Web with the password MGEUPS.

The card must be [restarted](#) in order for the new parameters to be taken into account.

6.4 Choice 4: Return to Default Configuration

Enables restoration of the [default configuration](#) of all the card's parameters

```
-----  
MGE UPS SYSTEMS  
NETWORK MANAGEMENT CARD  
-----  
1 : Reset  
2 : Network configuration  
3 : Set Login Password to Default  
4 : Return to Default Configuration  
0 : Exit  
-----  
Wait during configuration returns to default ...
```

Wait for the confirmation message.

```
Configuration has been set to default one.  
You must Reset the card.
```

The card must be [restarted](#) in order for the new parameters to be taken into account.

7 Industrial Network Management Card (INMC option)

7.1 Presentation

7.1.1 Overview

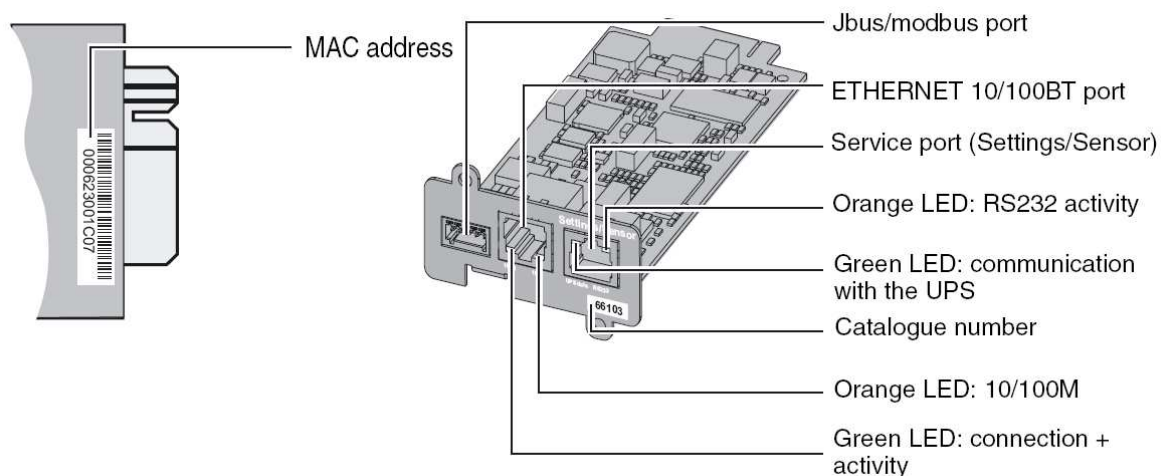

7.1.2 Functions

The Industrial Network Management Card (INMC) provides the same functions than the NMC card described in the previous section of this document.

The adding function consists to provide UPS (Uninterruptible Power Supply) data (states and measures) to be sent a computer system.

The JBUS hexadecimal (MODBUS RTU) communication protocol is used in slave mode. The system provides a communication channel with an RS485 or RS232 interface.

Note:

- 2 wires or 4 wires RS485 link are available.

Warning:

- RS232 and RS485 communication ports cannot be used together.
- JBUS/MODBUS communication is operational 2 minutes after the startup of the card.

7.1.3 Technical characteristics

Functions	Parameters	Default values	Possible values
JBUS/MODBUS communication	<ul style="list-style-type: none"> - Baud rate - Parity - Slave number 	<ul style="list-style-type: none"> - 9600 bauds - without parity - Slave nr 1 	<ul style="list-style-type: none"> - 1200, 2400, 4800, 9600 - Without parity, even parity - 1 to FF (hexadecimal)
RS232 link	<ul style="list-style-type: none"> - Link connection in transmit data (Tx) or receive data (Rx) 	<ul style="list-style-type: none"> - Rx on pin 1 - Tx on pin 3 	<ul style="list-style-type: none"> - Rx on pin 1 - Tx on pin 3
RS485 link	<ul style="list-style-type: none"> - Termination 	<ul style="list-style-type: none"> - No termination 	<ul style="list-style-type: none"> - With or without (2 or 4 wires)

7.2 Installation

7.2.1 RS232 link configuration and connection

Set the SA2 switches like below:

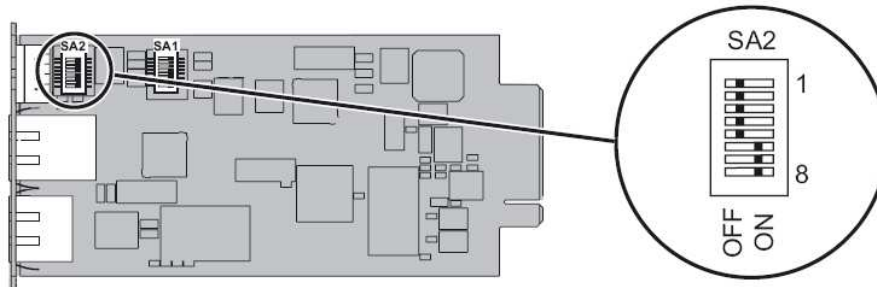

The next figure shows the details of the connection in RS232 mode:

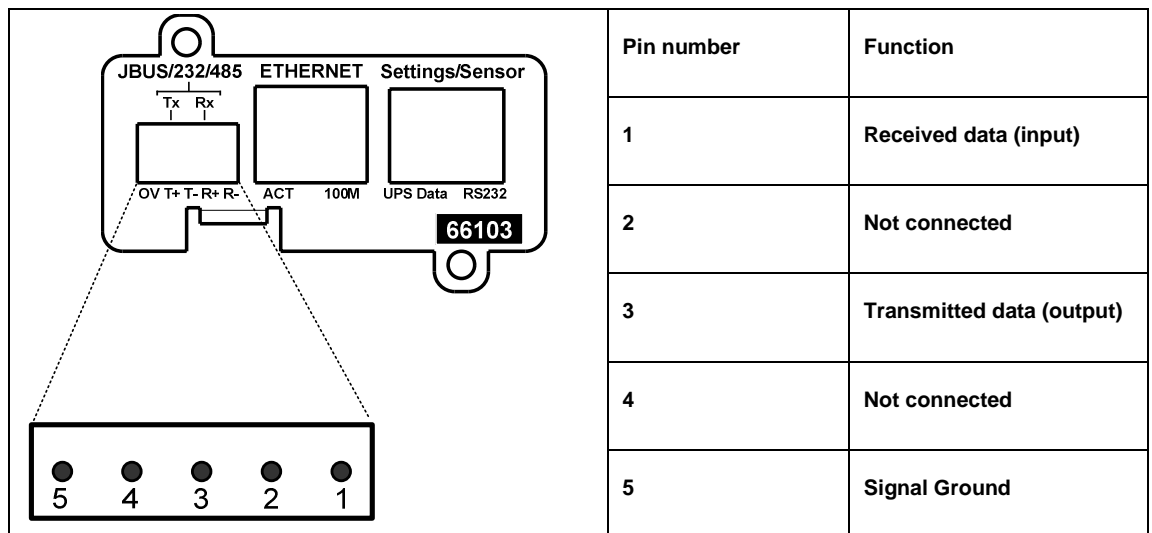

7.2.2 RS485 link configuration and connection

7.2.2.1 RS485 connection

La liaison EIA RS485, en 2 fils ou en 4 fils, doit être polarisée en un point unique de la ligne et adaptée aux deux extrémités de cette ligne pour un fonctionnement correct **A TRADUIRE**

Normally, the master of the network sets the polarity of the line. The INMC card is a slave equipment and don't have polarisation resistor.

The two ends of the line must be terminated. Allow for 1 or 2 terminators to avoid mismatching the line when any equipment at the end of the line is disconnected.

The next figure gives the detail of the RS485 connector and the internals drivers:

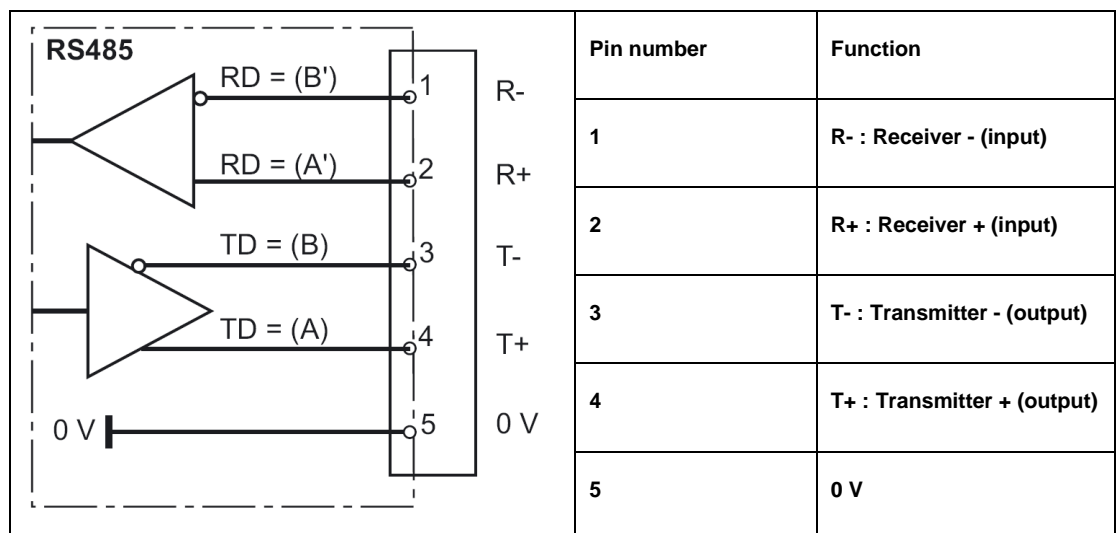

Important notes:

Use twisted pair cable (cable specification 0.3mm² and capacitance 42pF/m)

The transmission range will increase if a cable with lower capacitance and larger diameter is used.

Use shielded cable in heavy industrial environments.

The settings of the RS485 link are made through the SA1 switches:

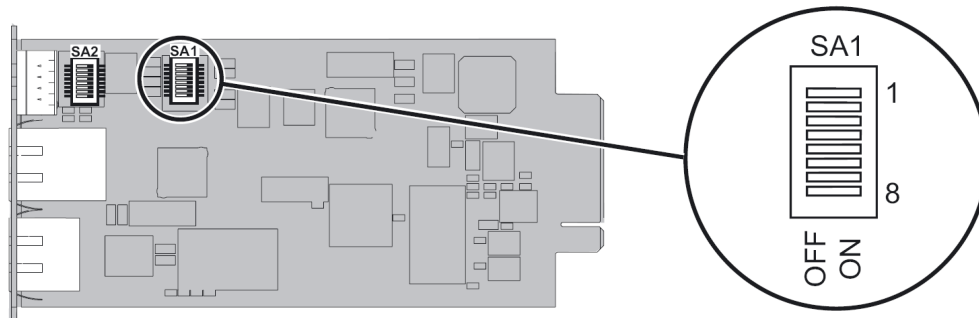

SA1 description:

1: reserved

2: reserved

3: link termination between T- to R- (2 wires configuration) if set to ON

4: connection T- to R- (2 wires configuration) if set to ON

5: connection T+ to R+ (2 wires configuration) if set to ON

6: reserved

7: reserved

8: link termination between R+ and R- if set to ON

7.2.2.2 RS485 link configuration for 2 wires connexion

Set the SA2 switches like below to set the RS485 mode:

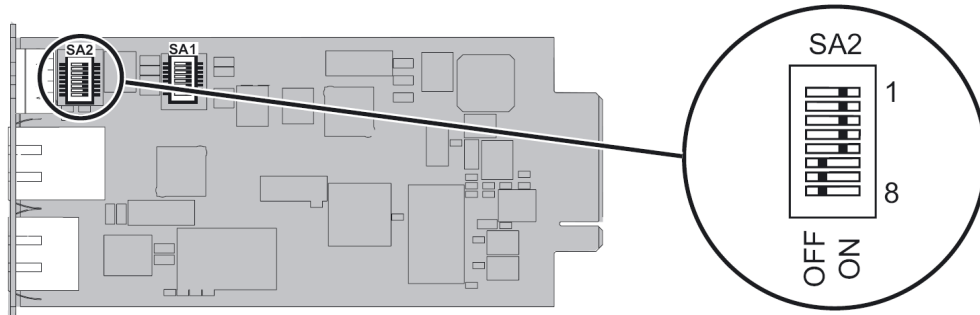

Set the SA1 switches to select the two wires configuration with no termination:

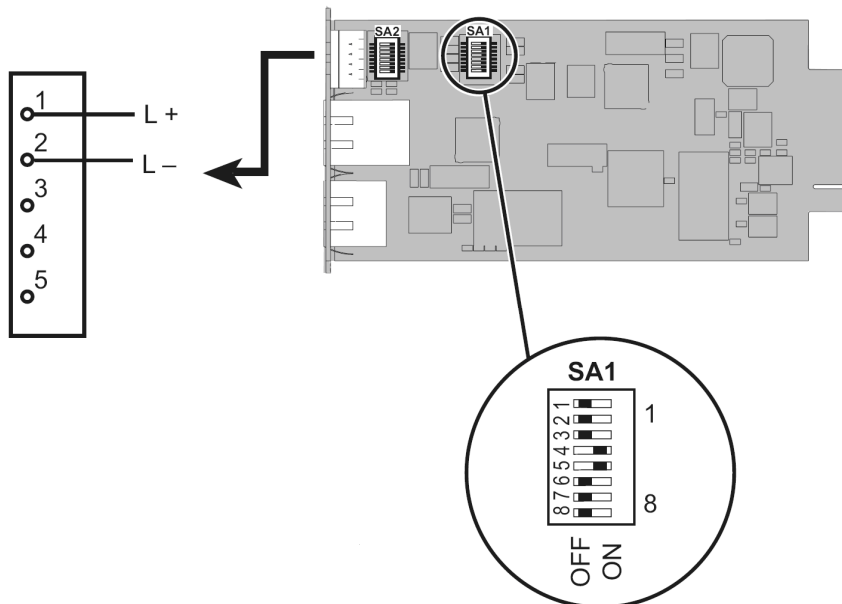

Set the SA1 switches to select the two wires configuration with termination:

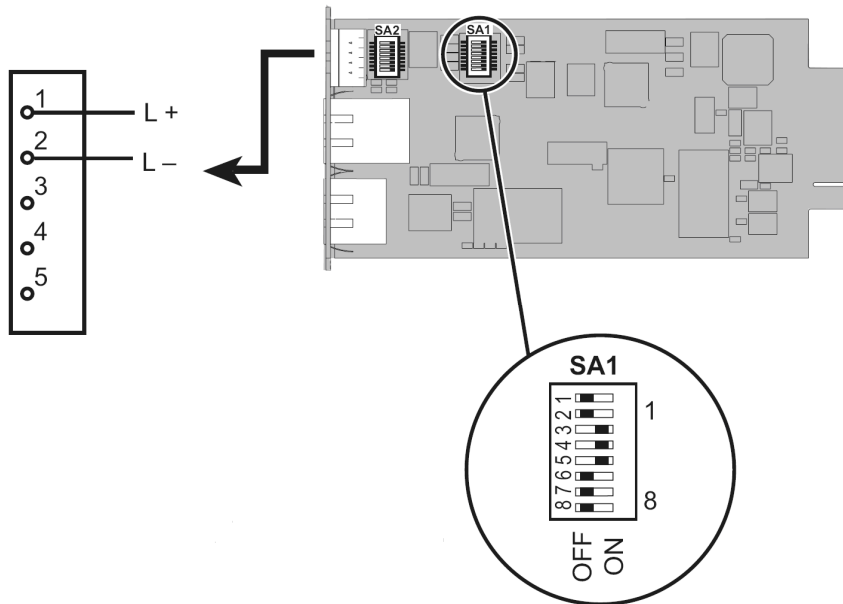

The next figure gives a typical bus structure in the two wires configuration:

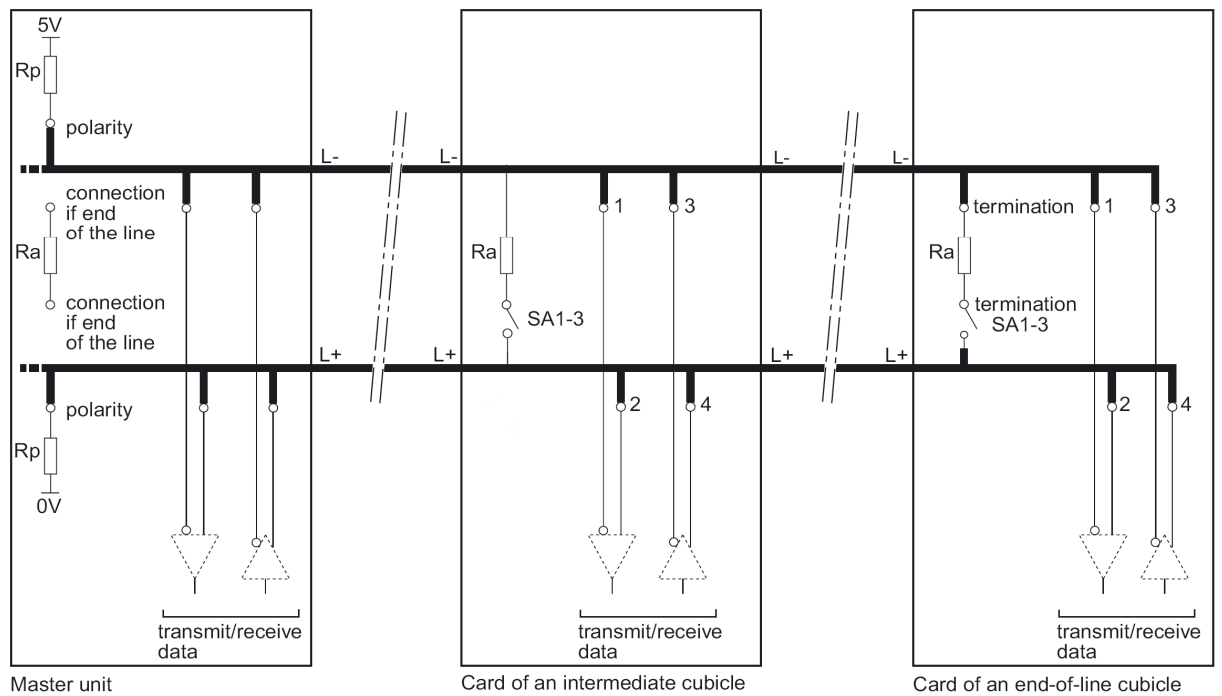

7.2.2.3 RS485 link configuration for 4 wires connexion

Set the SA2 switches like below:

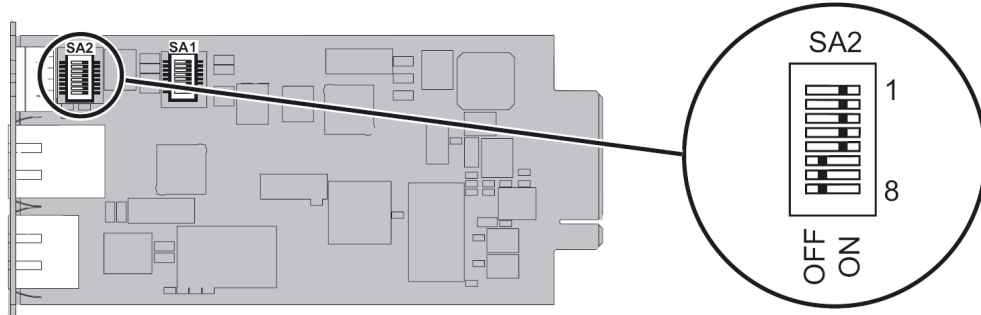

Set the SA1 switches to select the four wires configuration with no termination:

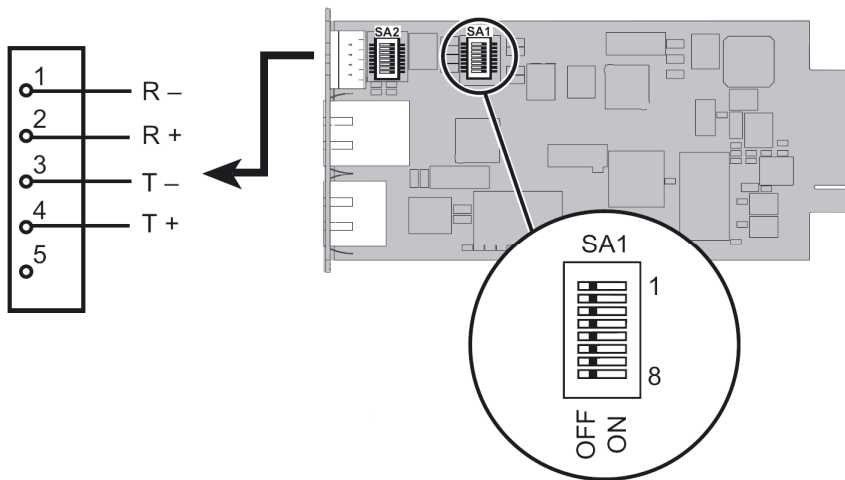

Set the SA1 switches to select the four wires configuration with termination:

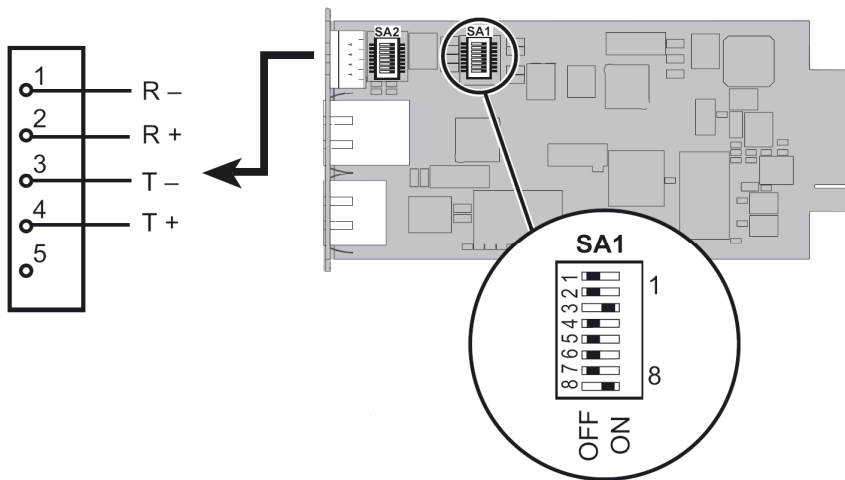

The next figure gives a typical bus structure in the four wires configuration:

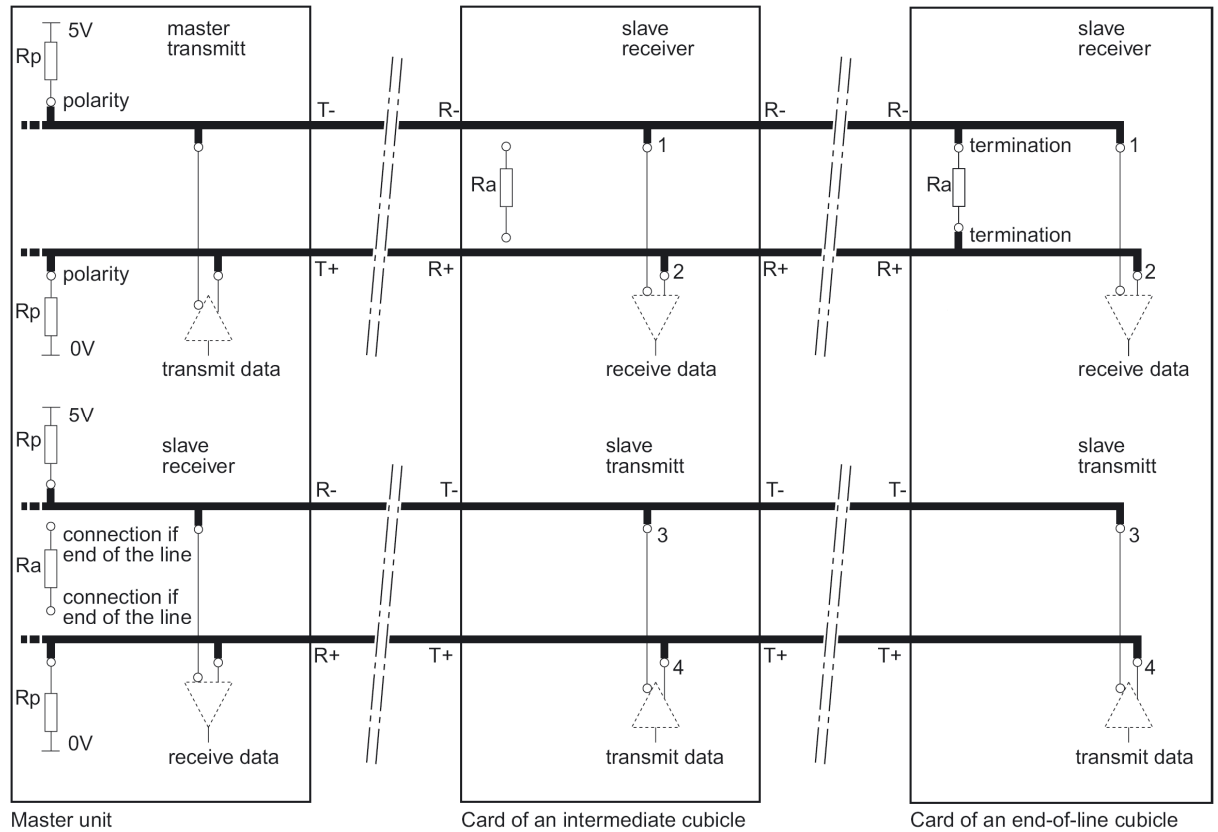

7.2.3 Configuration of the JBUS/MODBUS communication parameters

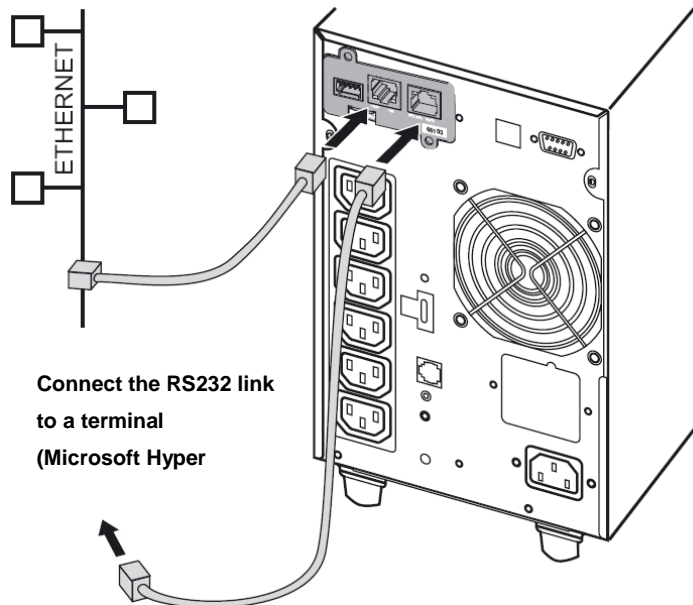

- Use the cord supplied with the card.

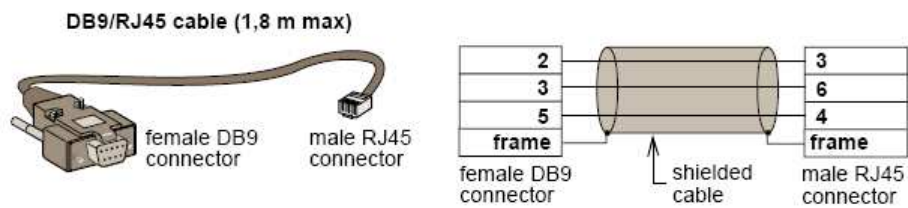

- Connect the card to a computer equipped with a Hyper terminal type emulator. The serial link must be set at 9600 baud, 8 bits, no parity, 1 stop bit, and without flow control.
- Check that UPS power is on.
- Enter the MGEUPS or mgeups password (not modifiable).

- ▶ The next menu appears:

```

-----
MGE UPS SYSTEMS
NETWORK MANAGEMENT CARD
-----
1 : Reset
2 : Network configuration
3 : Set Login Password to Default
4 : Return to Default Configuration
5 : Jbus configuration
6 : Sensor configuration
0 : Exit
-----

```

- ▶ Type 5 and return to display the JBUS configuration menu.



- ▶ The next menu appears:

```

-----
Jbus settings
-----
1 : Display Jbus settings
2 : Modify Jbus settings
3 : Display Jbus diagnostics
4 : Reset Jbus diagnostics
5 : Return to Jbus Default Configuration
6 : Display Jbus frames
0 : Exit
-----

```

7.2.3.1 Choice 1: Display Jbus settings

Enables reading of the card's Jbus settings

```

Jbus configuration :
Slave number : 7
Speed : 9600 bds
Data : 8 bits
stop bit : 1
Parity : None

```

7.2.3.2 Choice 2: Modify Jbus settings

Enables the modification of Jbus settings.

Setting Jbus configuration :

Set Slave number : 0x7

Set the Baud Rate [1: 38400, 2: 19200, 3: 9600, 4: 4800, 5: 2400, 6: 1200] :3

Set data format [1: 8 bits, 2: 7 bits] :1

Set stop bit [1: 1 bits, 2: 2 bits] :1

Set Parity [1: None, 2: Even, 3: Odd] :1

Wait during the new setting is saved ...

TLS/ Slave JBUS initialized

The Jbus configuration is now updated.

7.2.3.3 Choice 3: Display Jbus diagnostics

Enables reading of the Jbus diagnostics.

Jbus diagnostics :

Cpt1 - Bus Message Count:0

Cpt2 - CRC Error Count :0

Cpt3 - Slave Exception Error Count:0

Cpt4 - Slave Message Count:0

Cpt5 - Slave No Response Count:0

Cpt6 - Slave NAK Count:0

Cpt7 - Slave Busy Count:0

Cpt8 - Bus Character Overrun Count:0

Cpt9 - Slave Correct Response Count:0

7.2.3.4 Choice 4: Reset Jbus diagnostics

Reset the Jbus diagnostic counters.

7.2.3.5 Choice 5: Return to Jbus Default Configuration

Returns to the Jbus default configuration (0x01, 9600, 8, 1, none)

Wait during Jbus configuration returns to default ...

Jbus Configuration has been set to default one.

7.2.3.6 Choice 6: Display Jbus frames

Enables the display of the Jbus frames:

```
Recv : 01 01 00 00 00 64 3d e1
```

```
Send : 01 81 02 c1 91
```

```
Recv : 01 03 00 62 00 64 e5 ff
```

```
Send : 01 03 c8 00 00 00 00 00 00 00 00 00 00 00 00 ...
```

```
Recv : 01 01 00 00 00 64 3d e1
```

```
Send : 01 81 02 c1 91
```

```
Recv : 01 03 00 62 00 64 e5 ff
```

```
Send : 01 03 c8 00 00 00 00 00 00 00 00 00 00 00 ...
```

7.3 Additional Web pages

The INMC card Jbus parameters could be set through the next page:

MGE
Office Protection Systems

Network Management Card & ModBus/JBus

ModBus/JBus Settings Help

Pulsar 1000 RT2U Computer Room

Slave Number (Hex) :	<input type="text" value="1"/>
Serial speed :	<input type="text" value="9600"/>
Data format :	<input type="text" value="8"/>
Stop bit :	<input type="text" value="1"/>
Parity :	<input type="text" value="Even"/>

Save modified settings :

Export settings to file :

Import settings from file :

7.4 JBUS table

7.4.1 Data for Pulsar 700 / 1000 / 1500

7.4.1.1 Status table

Status description	Status to 0	Status to 1	Word (hex)	Bit
Load protected	no	yes	40	0
UPS coupled	no	yes	40	1
Unit general alarm	no	yes	40	2
UPS in backup	no	yes	40	4
Battery low warning	no	yes	40	5
Low battery	no	yes	40	6
Operation on static switch	no	yes	40	7
Communication fault	absent	present	40	9
UPS overload	no	yes	40	A
Emergency stop	absent	present	40	B
Battery to be checked	no	yes	40	D
Device ventilation fault	no	yes	40	E
Battery present	absent	present	42	0
Mains 1 voltage out of tolerance	no	yes	44	8
Mains 1 frequency out of tolerance	no	yes	44	B
Bypass status	no	yes	46	7
Charger general fault	no	yes	49	0
Battery charge	not in charge	in charge	49	1 & 3
Converter fault	no	yes	4A	1
Inverter fault	no	yes	4C	1

7.4.1.2 Measurements table

Description of the physical quantity	Word (hex)	Unit
I output	109	A
U output	124	V
U battery	12D	V
Output active power	136	W
Output apparent power	137	VA
% output load level	139	%
Power factor (Cos PHI)	13D	-
Mains 1 frequency	13E	Hz
Output frequency	141	Hz
Battery backup time	149	Min
Battery charging level	14B	%
U mains 1	150	V
Nominal voltage of battery element	213	V

7.4.2 Data for Pulsar M 2200 / 3000

7.4.2.1 Status table

Status description	Status to 0	Status to 1	Word (hex)	Bit
Load protected	no	yes	40	0
UPS coupled	no	yes	40	1
Unit general alarm	no	yes	40	2
UPS in backup	no	yes	40	4
Battery low warning	no	yes	40	5
Low battery	no	yes	40	6
Operation on static switch	no	yes	40	7
Communication fault	absent	present	40	9
UPS overload	no	yes	40	A
Emergency stop	absent	present	40	B
Battery to be checked	no	yes	40	D
Device ventilation fault	no	yes	40	E
Manual bypass switch (Q3BP)	open	closed	41	6
Battery present	absent	present	42	0
Mains 1 voltage out of tolerance	no	yes	44	8
Mains 1 frequency out of tolerance	no	yes	44	B
Redundancy lost	no	yes	45	7
Maintenance position	no	yes	46	1
Mains 2 overload	no	yes	46	5
Output on bypass	no	yes	46	7
Mains 2 frequency out of tolerance	no	yes	46	9
Mains 2 voltage out of tolerance	no	yes	46	A
Phase M2 out of tolerance	no	yes	46	B
Charger general fault	no	yes	49	0
Battery charge	no	yes	49	1 & 3
Converter fault	no	yes	4A	1
Inverter major fault	no	yes	4C	1

7.4.2.2 Measurements table

Description of the physical quantity	Word (hex)	Unit
I mains 2	106	A
I output	109	A
U mains 2	11E	V
U output	124	V
U battery	12D	V
Output active power	136	W
Output apparent power	137	VA
% output load level	139	%
Power factor x 100	13D	-
Mains 1 frequency	13E	dHz
Output frequency	141	dHz
Battery backup time	149	Min
Battery charging level	14B	%
U mains 1	150	V
Nominal voltage of battery element	213	V

7.4.3 Data for Pulsar MX 4000 / 5000 / 10000

7.4.3.1 Status table

Status description	Status to 0	Status to 1	Word (hex)	Bit
Load protected	no	yes	40	0
UPS coupled	no	yes	40	1
Unit general alarm	no	yes	40	2
UPS in backup	no	yes	40	4
Battery low warning	no	yes	40	5
Low battery	no	yes	40	6
Operation on static switch	no	yes	40	7
Communication fault	absent	present	40	9
UPS overload	no	yes	40	A
Emergency stop	absent	present	40	B
Battery to be checked	no	yes	40	D
Device ventilation fault	no	yes	40	E
Manual bypass switch (Q3BP)	open	closed	41	6
UPS in "eco" mode	no	yes	41	7
Battery present	absent	present	42	0
Mains 1 voltage out of tolerance	no	yes	44	8
Mains 1 fuse fault	no	yes	44	9
Mains 1 frequency out of tolerance	no	yes	44	B
Redundancy lost	no	yes	45	7
Maintenance position	no	yes	46	1
Mains 2 overload	no	yes	46	5
Mains 2 thermal overload	no	yes	46	6
Output on bypass	no	yes	46	7
Mains 2 frequency out of tolerance	no	yes	46	9
Mains 2 voltage out of tolerance	no	yes	46	A
Phase M2 out of tolerance	no	yes	46	B
Mains 2 internal fault	absent	present	47	2
Charger general fault	no	yes	49	0
Battery charge	no	yes	49	1 & 3
Converter fault	no	yes	4A	1
Inverter major fault	no	yes	4C	1
Inverter overload	no	yes	4C	2
Inverter thermal overload	no	yes	4C	3
Inverter limitation	no	yes	4C	4
UPS fuse fault	absent	present	4C	5

7.4.3.2 Measurements table

Description of the physical quantity	Word (hex)	Unit
I mains 1	100	A
I mains 2	106	A
I output	109	A
I battery	10E	A
U mains 2	11E	V
U output	124	V
U battery	12D	V
Output active power	136	W
Output apparent power	137	VA
% output load level	139	%
Power factor (Cos PHI)	13D	-
Mains 1 frequency	13E	dHz
Mains 2 frequency	140	dHz
Output frequency	141	dHz
Battery backup time	149	Min
Battery charging level	14B	%
U mains 1	150	V
Nominal voltage of battery element	213	V

7.4.4 Data for Pulsar MX frame 15 / 20

7.4.4.1 Status table

Status description	Status to 0	Status to 1	Word (hex)	Bit
Load protected	no	yes	40	0
UPS coupled	no	yes	40	1
Unit general alarm	no	yes	40	2
UPS in backup	no	yes	40	4
Battery low warning	no	yes	40	5
Low battery	no	yes	40	6
Operation on static switch	no	yes	40	7
Communication fault	absent	present	40	9
UPS overload	no	yes	40	A
Emergency stop	absent	present	40	B
Battery to be checked	no	yes	40	D
Device ventilation fault	no	yes	40	E
Manual bypass switch (Q3BP)	open	closed	41	6
Battery present	absent	present	42	0
Mains 1 voltage out of tolerance	no	yes	44	8
Mains 1 fuse fault	no	yes	44	9
Mains 1 frequency out of tolerance	no	yes	44	B
Redundancy lost	no	yes	45	7
Maintenance position	no	yes	46	1
Mains 2 overload	no	yes	46	5
Mains 2 thermal overload	no	yes	46	6
Output on bypass	no	yes	46	7
Mains 2 frequency out of tolerance	no	yes	46	9
Mains 2 voltage out of tolerance	no	yes	46	A
Phase M2 out of tolerance	no	yes	46	B
Mains 2 internal fault	absent	present	47	2
Charger general fault	no	yes	49	0
Battery charge	no	yes	49	1 & 3
Inverter major fault	no	yes	4C	1
Inverter overload	no	yes	4C	2
Inverter thermal overload	no	yes	4C	3
Inverter limitation	no	yes	4C	4
UPS fuse fault	absent	present	4C	5

7.4.4.2 Modular fault table

Description du Status		Status to 0	Status to 1	Word (hex)	Bit
Module 1	General alarm	Absent	Present	61	0
	Fan failure	Absent	Present	61	1
	Internal communication fault	Absent	Present	61	2
	Inverter thermal overload	Absent	Present	61	3
	Inverter fault	Absent	Present	61	4
	Inverter fuse blown	Absent	Present	61	5
	Load short circuit	Absent	Present	61	6
Module 2	General alarm	Absent	Present	62	0
	Fan failure	Absent	Present	62	1
	Internal communication fault	Absent	Present	62	2
	Inverter thermal overload	Absent	Present	62	3
	Inverter fault	Absent	Present	62	4
	Inverter fuse blown	Absent	Present	62	5
	Load short circuit	Absent	Present	62	6
Module 3	General alarm	Absent	Present	63	0
	Fan failure	Absent	Present	63	1
	Internal communication fault	Absent	Present	63	2
	Inverter thermal overload	Absent	Present	63	3
	Inverter fault	Absent	Present	63	4
	Inverter fuse blown	Absent	Present	63	5
	Load short circuit	Absent	Present	63	6
Module 4	General alarm	Absent	Present	64	0
	Fan failure	Absent	Present	64	1
	Internal communication fault	Absent	Present	64	2
	Inverter thermal overload	Absent	Present	64	3
	Inverter fault	Absent	Present	64	4
	Inverter fuse blown	Absent	Present	64	5
	Load short circuit	Absent	Present	64	6

Description du Status		Status to 0	Status to 1	Word (hex)	Bit
Module 5	General alarm	Absent	Present	65	0
	Fan failure	Absent	Present	65	1
	Internal communication fault	Absent	Present	65	2
	Inverter thermal overload	Absent	Present	65	3
	Inverter fault	Absent	Present	65	4
	Inverter fuse blown	Absent	Present	65	5
	Load short circuit	Absent	Present	65	6
Module 6	General alarm	Absent	Present	66	0
	Fan failure	Absent	Present	66	1
	Internal communication fault	Absent	Present	66	2
	Inverter thermal overload	Absent	Present	66	3
	Inverter fault	Absent	Present	66	4
	Inverter fuse blown	Absent	Present	66	5
	Load short circuit	Absent	Present	66	6
Module 7	General alarm	Absent	Present	67	0
	Fan failure	Absent	Present	67	1
	Internal communication fault	Absent	Present	67	2
	Inverter thermal overload	Absent	Present	67	3
	Inverter fault	Absent	Present	67	4
	Inverter fuse blown	Absent	Present	67	5
	Load short circuit	Absent	Present	67	6
Module 8	General alarm	Absent	Present	68	0
	Fan failure	Absent	Present	68	1
	Internal communication fault	Absent	Present	68	2
	Inverter thermal overload	Absent	Present	68	3
	Inverter fault	Absent	Present	68	4
	Inverter fuse blown	Absent	Present	68	5
	Load short circuit	Absent	Present	68	6

7.4.4.3 Measurements table

Description of the physical quantity	Word (hex)	Unit
I1 (I phase 1) mains 1	100	A
I2 (I phase 2) mains 1	101	A
I3 (I phase 3) mains 1	102	A
I1 (I phase 1) mains 2	106	A
I2 (I phase 2) mains 2	107	A
I3 (I phase 3) mains 2	108	A
I1 (I phase 1) output	109	A
I2 (I phase 2) output	10A	A
I3 (I phase 3) output	10B	A
I battery	10E	A
U12 mains 1	115	V
U23 mains 1	116	V
U31 mains 1	117	V
U mains 2 (phase 1)	11E	V
U mains 2 (phase 2)	11F	V
U mains 2 (phase 3)	120	V
U12 mains 2	121	V
U23 mains 2	122	V
U31 mains 2	123	V
U1N output	124	V
U2N output	125	V
U3N output	126	V
U12 output	127	V
U23 output	128	V
U31 output	129	V
U battery	12D	V
Output active power (phase 1)	130	W
Output active power (phase 2)	131	W
Output active power (phase 3)	132	W
Output apparent power (phase 1)	133	VA
Output apparent power (phase 2)	134	VA
Output apparent power (phase 3)	135	VA
Output total active power	136	W
Output total apparent power	137	VA
% output load level	139	%
Peak factor phase 1 x 100	13A	-
Peak factor phase 2 x 100	13B	-
Peak factor phase 3 x 100	13C	-
Power factor x 100	13D	-
Mains 1 frequency	13E	dHz
Mains 2 frequency	140	dHz
Output frequency	141	dHz
Battery backup time	149	Min
Battery charging level	14B	%

Description of the physical quantity	Word (hex)	Unit
U mains 1 (phase 1)	150	V
U mains 1 (phase 2)	151	V
U mains 1 (phase 3)	152	V
Nominal voltage of battery element	213	V

7.4.5 Sensor data

7.4.5.1 Status table

Status description	Status to 0	Status to 1	Word (hex)	Bit
Input 1 alarm	no	yes	45	5
Input 2 alarm	no	yes	45	6
Alarm : humidity too low	no	yes	45	4
Alarm : humidity too high	no	yes	45	3
Alarm : temperature too low	no	yes	45	2
Alarm : temperature too high	no	yes	45	1
Communication fault	no	yes	45	0
Input 1	open	close	48	0
Input 2	open	close	48	1

7.4.5.2 Measurements table

Description of the physical quantity	Word (hex)	Unit
Temperature measure	180	°C / °F
Maximum temperature	181	°C / °F
Maximum temperature date (MSB) in Unix timestamp	182	
Maximum temperature date (LSB) in Unix timestamp	183	
Minimum temperature (°C)	184	°C / °F
Minimum temperature date (MSB) in Unix timestamp	185	
Minimum temperature date (LSB) in Unix timestamp	186	
Humidity measure (%)	187	%
Maximum humidity (%)	188	%
Maximum humidity date (MSB) in Unix timestamp	189	
Maximum humidity date (LSB) in Unix timestamp	190	
Minimum humidity (%)	18B	%
Minimum humidity date (MSB) in Unix timestamp	192	
Minimum humidity date (LSB) in Unix timestamp	193	
Input 1 changing date (MSB) in Unix timestamp	194	
Input 1 changing date (LSB) in Unix timestamp	195	
Input 2 changing date (MSB) in Unix timestamp	196	
Input 2 changing date (LSB) in Unix timestamp	197	

7.4.5.3 Read of the personalization table

Description	Word (hex)	Unit
High threshold temperature (°C)	32C	0
Low threshold temperature (°C)	32D	0
Temperature hysteresis (°C)	32E	0
Offset temperature	32F	0
High threshold humidity (%)	330	0
Low threshold humidity (%)	331	0
Humidity hysteresis (%)	332	0
Humidity offset	333	0
Inputs call mask – input 1 close notification	334	0
Inputs call mask – input 2 close notification	334	2
Inputs call mask – low humidity notification	334	7
Inputs call mask – high humidity notification	334	6
Inputs call mask – input 1 open notification	334	1
Inputs call mask – input 2 open notification	334	3
Inputs call mask – low temperature notification	334	5
Inputs call mask – high temperature notification	334	4
Input 1 identification	336	0
Input 2 identification	33A	0

7.4.6 Other data

Information description	Word (hex)	Example
Manufacturer name	1A0	« MGE Office Protection Systems »
Product name	1A8	« Pulsar »
UPS model	1B0	« 700 »
Serial number	1B8	« AN2E49008 »

8 Appendices

8.1 Tables of alarms and events

8.1.1 Table of alarms

List of time dated alarms

Alarm on	Alarm off
Battery fuse blown	Battery fuse OK
No Battery	Battery present
Battery temperature fault	Battery temperature OK
Battery charger fault	Battery charger OK
Battery fault	Battery OK
MAX charger voltage fault	Charger voltage OK
MIN charger voltage fault	Charger voltage OK
Charger temperature fault	Charger temperature OK
Rectifier fault	Rectifier OK
Chopper fault	Chopper OK
Normal AC frequency out of tolerance	Normal AC frequency OK
Normal AC fuses blown	Normal AC fuses OK
Normal AC module fault	Normal AC module OK
Normal AC voltage out of tolerance	Normal AC voltage OK
Normal AC NOK	Normal AC OK
Site wiring fault	Site wiring OK
Bypass AC frequency out of tolerance	Bypass AC frequency OK
Bypass AC phase out of tolerance	Bypass AC phase OK
Bypass AC voltage out of tolerance	Bypass AC voltage OK
Automatic Bypass fault	Automatic Bypass OK
Automatic Bypass overload	Automatic Bypass load OK
Automatic Bypass overtemperature	Automatic Bypass temperature OK
Automatic Bypass thermal overload	Automatic Bypass load OK
Automatic Bypass switch (Q4S) open	Automatic Bypass switch (Q4S) closed
Normal AC switch (Q1) open	Normal AC switch (Q1) closed
Battery switch (QF1) open	Battery switch (QF1) closed
Manual Bypass switch (Q3BP) closed	Manual Bypass switch (Q3BP) open
UPS on manual bypass	
Output switch (Q5N) open	Output switch (Q5N) closed
Single wave load fault	Load OK
Negative DC bus too high	Negative DC bus OK
Positive DC bus too high	Positive DC bus OK
Negative DC bus too low	Negative DC bus OK
Positive DC bus too low	Positive DC bus OK
Inverter limitation	Inverter end of limitation
Inverter fuses blown	Input fuses OK
Inverter fault	Inverter OK

Inverter overload	Inverter load OK
Inverter over temperature	Inverter temperature OK
Inverter short circuit	Inverter OK
Inverter thermal overload	Inverter load OK
Load not protected - On Automatic Bypass	Load protected - Return from Bypass
Load short circuit	Load OK
Load not powered	Load powered
Protection Lost	Protection OK
Emergency button ON	Emergency button OFF
Fan fault	Fan OK
Redundancy Lost	Redundancy OK
Low battery	Battery OK
UPS communication failed	UPS communication restored
UPS data base not available	UPS data base OK
UPS on battery	UPS on normal AC
UPS internal fault	UPS OK
UPS overload	UPS returns to normal load
UPS overtemperature	UPS temperature OK
Imminent UPS shutoff	UPS OK
<Sensor name>:	<Sensor name>:
Temperature is above high threshold xx °C	La température est au dessus du seuil haut xx °C
<Sensor name>:	<Sensor name>:
Humidity is above high threshold xx %	L'humidité est au dessus du seuil haut xx %
<Sensor name>:	<Sensor name>:
Temperature is below low threshold xx °C	La température est en dessous du seuil bas xx °C
<Sensor name>:	<Sensor name>:
Humidity is below low threshold xx %	L'humidité est en dessous du seuil bas xx %
<Sensor name>: <Input #1 label> <when closed label>	<Sensor name>: <Input #1 label> <when closed label>
<Sensor name>: <Input #1 label> <when open label>	<Sensor name>: <Input #1 label> <when open label>
<Sensor name>: <Input #2 label> <when closed label>	<Sensor name>: <Input #2 label> <when closed label>
<Sensor name>: <Input #2 label> <when open label>	<Sensor name>: <Input #2 label> <when open label>

If the UPS is modular UPS, for each module:

Battery fuse blown	Battery fuse OK
No Battery	Battery present
Battery temperature fault	Battery temperature OK
Battery charger fault	Battery charger OK
Low battery	Battery OK
Charger temperature fault	Charger temperature OK
MAX charger voltage fault	Charger voltage OK
MIN charger voltage fault	Charger voltage OK
Chopper fault	Chopper OK
Normal AC fuses blown	Normal AC fuses OK
Normal AC module fault	Normal AC module OK
Inverter fuses blown	Input fuses OK
Inverter fault	Inverter OK
Inverter short circuit	Inverter OK
Load short circuit	Load OK
Rectifier fuse blown	Rectifier OK
Rectifier fault	Rectifier OK
DC bus unbalanced	Load OK
Emergency button ON	Emergency button OFF
Load not powered	Load powered
UPS internal fault	UPS OK
Battery fault	Battery OK
Imminent UPS shutoff	UPS OK
Normal AC frequency out of tolerance	Normal AC frequency OK
Normal AC voltage out of tolerance	Normal AC voltage OK
Normal AC switch (Q1) open	Normal AC switch (Q1) closed
Site wiring fault	Site wiring OK
Automatic Bypass switch (Q4S) open	Automatic Bypass switch (Q4S) closed
Bypass AC frequency out of tolerance	Bypass AC frequency OK
Automatic Bypass fault	Automatic Bypass OK
Automatic Bypass overload	Automatic Bypass load OK
Automatic Bypass overtemperature	Automatic Bypass temperature OK
Automatic Bypass thermal overload	Automatic Bypass load OK
Bypass AC phase out of tolerance	Bypass AC phase OK
Bypass AC voltage out of tolerance	Bypass AC voltage OK
Load not protected - On Automatic Bypass	Load protected - Return from Bypass
Battery switch (QF1) open	Battery switch (QF1) closed
Manual Bypass switch (Q3BP) closed	Manual Bypass switch (Q3BP) open
UPS on manual bypass	
Inverter limitation	Inverter end of limitation
Inverter overload	Inverter load OK
Inverter overtemperature	Inverter temperature OK
Inverter thermal overload	Inverter load OK
Negative DC bus too high	Negative DC bus OK
Positive DC bus too high	Positive DC bus OK
Negative DC bus too low	Negative DC bus OK

Positive DC bus too low
 Output switch (Q5N) open
 Normal AC NOK
 UPS on battery
 UPS overload
 UPS overtemperature
 Fan fault
 UPS communication failed

Positive DC bus OK
 Output switch (Q5N) closed
 Normal AC OK
 UPS on normal AC
 UPS returns to normal load
 UPS temperature OK
 Fan OK
 UPS communication restored

8.1.2 Table of UPS events

List of time dated informations

Alarm on	Alarm off
Battery fuse blown	Battery fuse OK
Battery temperature fault	Battery temperature OK
No Battery	Battery present
Battery charger fault	Battery charger OK
Charger temperature fault	Charger temperature OK
MAX charger voltage fault	Charger voltage OK
MIN charger voltage fault	Charger voltage OK
End of Warranty	LCM message OK
End of battery life	LCM message OK
End of life of the wearing parts	LCM message OK
Outlet 1 open	Outlet 1 closed
Outlet 2 open	Outlet 2 closed
Chopper fault	Chopper OK
Normal AC switch (Q1) open	Normal AC switch (Q1) closed
Normal AC frequency out of tolerance	Normal AC frequency OK
Normal AC fuses blown	Normal AC fuses OK
Normal AC module fault	Normal AC module OK
Normal AC voltage out of tolerance	Normal AC voltage OK
Site wiring fault	Site wiring OK
Automatic Bypass switch (Q4S) open	Automatic Bypass switch (Q4S) closed
Bypass AC frequency out of tolerance	Bypass AC frequency OK
Automatic Bypass fault	Automatic Bypass OK
Automatic Bypass overload	Automatic Bypass load OK
Automatic Bypass overtemperature	Automatic Bypass temperature OK
Bypass AC phase out of tolerance	Bypass AC phase OK
Automatic Bypass thermal overload	Automatic Bypass load OK
Load not protected - On Automatic Bypass	Load protected - Return from Bypass
Bypass AC voltage out of tolerance	Bypass AC voltage OK
Battery switch (QF1) open	Battery switch (QF1) closed
Manual Bypass switch (Q3BP) closed	Manual Bypass switch (Q3BP) open
UPS on manual bypass	
Inverter limitation	Inverter end of limitation
Inverter fuses blown	Input fuses OK

Inverter fault	Inverter OK
Inverter overload	Inverter load OK
Inverter overtemperature	Inverter temperature OK
Inverter short circuit	Inverter OK
Inverter thermal overload	Inverter load OK
Output switch (Q5N) open	Output switch (Q5N) closed
Load short circuit	Load OK
Single wave load fault	Load OK
Negative DC bus too high	Negative DC bus OK
Positive DC bus too high	Positive DC bus OK
Rectifier fault	Rectifier OK
Negative DC bus too low	Negative DC bus OK
Positive DC bus too low	Positive DC bus OK
Protection Lost	Protection OK
Redundancy Lost	Redundancy OK
Normal AC NOK	Normal AC OK
Low battery	Battery OK
UPS communication failed	UPS communication restored
UPS data base not available	UPS data base OK
UPS on battery	UPS on normal AC
Emergency button ON	Emergency button OFF
Fan fault	Fan OK
Load not powered	Load powered
UPS internal fault	UPS OK
Battery fault	Battery OK
UPS overload	UPS returns to normal load
UPS overtemperature	UPS temperature OK
Imminent UPS shutoff	UPS OK
< Sensor Name> : Temperature is above high threshold <xx> (°C) or (°F)	<Sensor Name> : Temperature is in normal range
< Sensor Name> : Humidity is above high threshold <xx> (%)	<Sensor Name> : Temperature is in normal range
< Sensor Name> : Temperature is below low threshold <xx> °C or (°F)	<Sensor Name> : Temperature is in normal range
< Sensor Name> : Humidity is below high threshold <xx> (%)	<Sensor Name> : Temperature is in normal range
<Sensor name>: <Input #1 label> <when closed label>	
<Sensor name>: <Input #1 label> <when open label>	
<Sensor name>: <Input #2 label> <when closed label>	
<Sensor name>: <Input #2 label> <when open label>>	

8.1.3 Table of system alarms

Network Management Card startup
Send test mail SUCCESS
Send test mail ERROR
Send mail to <recipient> ERROR
<Sensor name> Communication failure
<Sensor name> Communication restored
Firmware upgraded
Connected NSM list Full, last connection refused
sendTrap()-> Unable to resolve hostname <hostname>
SNMP Send Trap # <num> failure to <hostname>
Time changed by user with yyyy/mm/dd hh:mm:ss
Time synchronized by NSM or EPM with yyyy/mm/dd hh:mm:ss

8.2 SNMP objects

8.2.1 MGE MIB

The NMC card implement reduce MGE Office Protection Systems MIB, with the objects bellow managed.

The entire MIB description is available on www.mgeops.com area "[Downloads – Software Download](#)".

Le chemin d'accès à la MIB MGE est 1.3.6.1.4.1.705.1.

MIB object	SNMP Format	Add.path
upsmgIdentFamilyName	String	{1,1,0}
upsmgIdentModelName	String	{1,2,0}
upsmgIdentFirmwareVersion	String	{1,4,0}
upsmgIdentSerialNumber	String	{1,7,0}
upsmgConfigLowBatteryTime	seconds	{4,7,0}
upsmgConfigLowBatteryLevel	%	{4,8,0}
upsmgConfigAutoRestart	1(yes) 2(no)	{4,9,0}
upsmgConfigVARating	VA	{4,12,0}
upsmgBatteryRemainingTime	seconds	{5,1,0}
upsmgBatteryLevel	%	{5,2,0}
upsmgBatteryVoltage	deciVolts	{5,5,0}
upsmgBatteryCurrent	deciAmps	{5,6,0}
upsmgBatteryFaultBattery	1(yes) 2(no)	{5,9,0}
upsmgBatteryReplacement	1(yes) 2(no)	{5,11,0}
upsmgBatteryLowBattery	1(yes) 2(no)	{5,14,0}
upsmgBatteryChargerFault	1(yes) 2(no)	{5,15,0}
upsmgBatteryLowCondition	1(yes) 2(no)	{5,16,0}
upsmgInputPhaseNum		{6,1,0}
mginputVoltage_1	DeciVolts	{6,2,1,2,1,0}
mginputVoltage_2	DeciVolts	{6,2,1,2,2,0}
mginputVoltage_3	DeciVolts	{6,2,1,2,3,0}
mginputFrequency_1	DeciHz	{6,2,1,3,1,0}
mginputFrequency_2	DeciHz	{6,2,1,3,2,0}
mginputFrequency_3	DeciHz	{6,2,1,3,3,0}
mginputMinimumVoltage		{6,2,1,4,0}
mginputMaximumVoltage		{6,2,1,5,0}
mginputCurrent_1	DeciAmps	{6,2,1,6,1,0}
mginputCurrent_2	DeciAmps	{6,2,1,6,2,0}
mginputCurrent_3	DeciAmps	{6,2,1,6,3,0}
upsmgInputBadStatus		{6,3,0}
upsmgInputLineFailCause		{6,4,0}
upsmgOutputPhaseNum		{7,1,0}
mgoutputPhaseIndex_1		{7,2,1,1,1,0}
mgoutputPhaseIndex_2		{7,2,1,1,2,0}
mgoutputPhaseIndex_3		{7,2,1,1,3,0}
mgoutputVoltage_1	deciVolts	{7,2,1,2,1,0}
mgoutputVoltage_2	deciVolts	{7,2,1,2,2,0}
mgoutputVoltage_3	deciVolts	{7,2,1,2,3,0}

mgoutputFrequency_1	deciHz	{7,2,1,3,1,0}
mgoutputFrequency_2	deciHz	{7,2,1,3,2,0}
mgoutputFrequency_3	deciHz	{7,2,1,3,3,0}
mgoutputLoadPerPhase_1	%	{7,2,1,4,1,0}
mgoutputLoadPerPhase_2	%	{7,2,1,4,2,0}
mgoutputLoadPerPhase_3	%	{7,2,1,4,3,0}
mgoutputCurrent_1	deciAmps	{7,2,1,5,1,0}
mgoutputCurrent_2	deciAmps	{7,2,1,5,2,0}
mgoutputCurrent_3	deciAmps	{7,2,1,5,3,0}
upsmgOutputOnBattery	1(yes) 2(no)	{7,3,0}
upsmgOutputOnByPass	1(yes) 2(no)	{7,4,0}
upsmgOutputUtilityOff	1(yes) 2(no)	{7,7,0}
upsmgOutputInverterOff	1(yes) 2(no)	{7,9,0}
upsmgOutputOverLoad	1(yes) 2(no)	{7,10,0}
upsmgOutputOverTemp	1(yes) 2(no)	{7,11,0}
upsmgAgentIpAddress		{12,1,0}
upsmgAgentSubnetMask		{12,2,0}
upsmgAgentDefGateway		{12,3,0}
upsmgAgentType		{12,6,0}
upsmgAgentMibVersion		{12,11,0}
upsmgAgentFirmwareVersion		{12,12,0}
upsmgAgentCommUPS	1(yes) 2(no)	{12,13,0}

If the Environment Sensor is detected , the following information are managed.

upsmgEnvironAmbientTemp	0.1 degré	{8,1,0}
upsmgEnvironAmbientHumidity	0.1 %	{8,2,0}
upsmgEnvironmentNum		{8,6,0}
upsmgEnvironmentIndex		{8,7,1,1,1 }
upsmgEnvironmentComFailure	1(yes) 2(no)	{8,7,1,2,1}
upsmgEnvironmentTemperature	0.1 degré	{8,7,1,3,1}
upsmgEnvironmentTemperatureLow	1(yes) 2(no)	{8,7,1,4,1}
upsmgEnvironmentTemperatureHigh	1(yes) 2(no)	{8,7,1,5,1}
upsmgEnvironmentHumidity	0.1 %	{8,7,1,6,1}
upsmgEnvironmentHumidityLow	1(yes) 2(no)	{8,7,1,7,1}
upsmgEnvironmentHumidityHigh	1(yes) 2(no)	{8,7,1,8,1}
upsmgEnvironmentInput1State	closed(1), open(2)	{8,7,1,9,1}
upsmgEnvironmentInput2State	closed(1), open(2)	{8,7,1,10,1}

8.2.2 Table des TRAPS : (1.3.6.1.4.1.705.1.11)

SNMP traps are sent when alarms appears and disappears.

Level : 1:informational , 2:major, 3:critical

MIB TRAP	Trap #	Level
-upsmgBatteryFault	Trap 1	Level 3
-upsmgBatteryOK	Trap 2	Level 1
-upsmgAtLowBattery	Trap 5	Level 3
-upsmgFromLowBattery	Trap 6	Level 1
-upsmgChargerFault	Trap 7	Level 3
-upsmgChargerOK	Trap 8	Level 1
-upsmgOnBattery	Trap 11	Level 2
-upsmgReturnFromBattery	Trap 12	Level 1
-upsmgOnByPass	Trap 13	Level 2
-upsmgReturnFromByPass	Trap 14	Level 1
-upsmgUtilityFailure	Trap 17	Level 2
-upsmgUtilityRestored	Trap 18	Level 1
-upsmgOverLoad	Trap 21	Level 3
-upsmgLoadOK	Trap 22	Level 1
-upsmgOverTemperature	Trap 23	Level 3
-upsmgTemperatureOK	Trap 24	Level 1
-upsmgOffToStart	Trap 29	Level 2
-upsmgOffInProgress	Trap 31	Level 3
-upsmgCommunicationFailure	Trap 37	Level 3
-upsmgCommunicationRestored	Trap 38	Level 1
-upsmgRedundancyLost	Trap 65	Level 2
-upsmgRedundancyOK	Trap 66	Level 2
-upsmgProtectionLost	Trap 67	Level 2
-upsmgProtectionOK	Trap 68	Level 2

If the Environment Sensor is detected , the following information are managed.:

- upsEnvironmentComFailure	Trap 53	Level 2
- upsEnvironmentComOK	Trap 54	Level 2
- upsEnvironmentTemperatureLow	Trap 55	Level 2
- upsEnvironmentTemperatureHigh	Trap 56	Level 2
- upsEnvironmentTemperatureOK	Trap 57	Level 2
- upsEnvironmentHumidityLow	Trap 58	Level 2
- upsEnvironmentHumidityHigh	Trap 59	Level 2
- upsEnvironmentHumidityOK	Trap 60	Level 2
- upsEnvironmentInput1Closed	Trap 61	Level 2

- upsEnvironmentInput1Open	Trap 62	Level 2
- upsEnvironmentInput2Open	Trap 64	Level 2
- upsEnvironmentInput2Closed	Trap 63	Level 2

The level is used to select traps to be sent to the supervisor. This adjustment is available from the “Notified applications” page

9 Glossary

Bootp:

Protocol based on UDP used to allocate an IP address corresponding to an Ethernet card during the startup phase. Defined by the RCF 951

Community name:

Access key to access SNMP agent information

DHCP Dynamic Host Configuration Protocol

This IETF protocol enables remote, automatic, self-configuration of the IP addresses of a workstation.

DNS Domain Name Sevice1

The DNS protocol ensure correspondence between the name of a machine and its IP address

E-mail

Electronic means of transmitting messages and/or files.

Gateway

Interconnection equipment between networks with different conventions, to enable communication between them

HTML

(HyperText Markup Language) Language used to describe hypertext pages on the web.

HTTPS : is the secure version of HTTP, the communication protocol of the World Wide Web. It was invented by Netscape Communications Corporation to provide authentication and encrypted communication and is used in electronic commerce.

IP

Internet Protocol. Network layer protocol in the TCP/IP stack offering a no-connection inter-network service . The IP protocol offers functions for addressing, service type specification, fragmentation and re-assembling and security. Defined in RFC 791.

MIB MANAGEMENT INFORMATION BASE

- Group of software commands to control and administrate a device through the network. Each type of device (server, hub, PC, UPS, etc.) has its own MIB

NETWORK MANAGEMENT CARD

Communication cards to supervise UPS and communicate with Network Shutdown Module to insure power protection on servers

NETWORK MANAGEMENT PROXY

Communication software installed on a PC connected to the UPS to supervise it and communicate with Network Shutdown Module to insure power protection on servers

ENERGIZE YOUR ENTERPRISE

Network Management Card – User Manual

34003991EN/DA

Page 117/120

NMS NETWORK MANAGEMENT STATION (SNMP)

The dedicated PC or workstation is used on the company's networks to administrate all devices connected to the network. Data are transmitted using the SNMP protocol. Popular NMS systems include HP OpenView, IBM Tivoli, CA Unicenter, etc.

NSM : NETWORK SHUTDOWN MODULE

Protection software installed on a PC or server to protect it

NTP Network Time Protocol

Protocol to position a set of machines on a network at the same time.

Programmable outlet (controlled outlet):

Outlet that can be remote-switched on or off. UM-Client components enable management of such outlets.

REBOOT: To restart a system after an interruption.

- To perform an obstacle-free "reboot", it is essential that the system is correctly and carefully shut down beforehand.
- The reboot is usually automatic if the computer is re-supplied with electricity (from the utility or from the UPS).

RFC

Request for Comments. All documents defining internal Internet operation.

SNMP (SIMPLE NETWORK MANAGEMENT PROTOCOL)

Protocol used to remote-supervise, administrate and control devices connected to a company network.

SMTP (SIMPLE MAIL TRANSFER PROTOCOL)

Enables message transfer between e-mail servers or between the client and its server. It is based on the server's port 25. It is described in RFC 821

SSL (Secure Sockets Layers) is a protocol developed by Netscape Communications Corporation for securing data transmission in commercial transactions on the Internet. Using public-key cryptography, SSL provides server authentication, data encryption, and data integrity for client/server communications

Subnet mask:

Mask of bits used to identify and differentiate the network address and the equipment address in an IP address.

Normally, the mask is automatically determined by the class of address, which defines in a unique manner the network part/equipment part division of the IP address.

- Class A: internet address: 255.0.0.0.
- Class B: internet address: 255.255.0.0.
- Class C: internet address: 255.255.255.0.

TCP/IP

Transmission Control Protocol/Internet Protocol. Common name of a series of protocols developed by the DOD in the US to help build Internet networks throughout the world.

Trap (SNMP) : This term describes an event that affects an MIB variable. Traps are sent to the manager, which is

programmed to perform specific tasks upon reception of the traps.

Free Manuals Download Website

<http://myh66.com>

<http://usermanuals.us>

<http://www.somanuals.com>

<http://www.4manuals.cc>

<http://www.manual-lib.com>

<http://www.404manual.com>

<http://www.luxmanual.com>

<http://aubethermostatmanual.com>

Golf course search by state

<http://golfingnear.com>

Email search by domain

<http://emailbydomain.com>

Auto manuals search

<http://auto.somanuals.com>

TV manuals search

<http://tv.somanuals.com>