

# EPS 6000 UPS Shared Systems User's Guide

**M G E**  
UPS SYSTEMS

# IMPORTANT SAFETY INSTRUCTION

**SAVE THESE INSTRUCTIONS** — This manual contains important instructions for the EPS 6000 series UPS Systems that must be followed during installation, operation and maintenance of the equipment.



## WARNING

**OPENING ENCLOSURES EXPOSES HAZARDOUS VOLTAGES. ALWAYS REFER SERVICE TO QUALIFIED PERSONEL ONLY**



## WARNING

**As standards, specifications, and designs are subject to change, please ask for confirmation of the information given in this publication.**

**This manual is a controlled document, pages should not individually be removed from this binder.**



## NOTE

**This equipment generates, uses, and can radiate radio frequency energy and, if not installed and used in accordance with instruction manual, may cause harmful interference to radio communications. Operation of this equipment in a residential area is likely to cause harmful interference in which case the user will be required to correct the interference at his own expense.**

---

prepared for:

EPS 6000  
Shared Systems  
User's Guide

**For service call**  
1-800-438-7373

86-130034-00 B00 11/96  
Copyright © 1996 MGE UPS Systems, Inc..  
All rights reserved. Printed in U.S.A.

**MGE UPS Systems**  
1660 Scenic Avenue  
Costa Mesa, CA 92626  
(714) 557-1636



---

# EPS 6000 UPS Shared Systems User's Guide

---

## Warranty

Seller warrants to the Ultimate Purchaser (the purchaser who buys for use, and not for resale) that all products furnished under this order and which are manufactured by Seller will conform to final specifications, drawings, samples and other written descriptions approved in writing by Seller, and will be free from defects in materials and workmanship. These warranties shall remain in effect for period of twelve (12) months after delivery to the Ultimate Purchaser. But if the Seller installs the equipment or supplies technical direction of installation by contract, said one year shall run from the completion of installation, provided installation is not unreasonably delayed by Ultimate Purchaser. Parts replaced or repaired in the warrant period shall carry the unexpired portion of the original warranty. A unit placed with the Purchaser on consignment and then later purchased will be warranted for twelve (12) months from the time the Seller receives notification of the Purchaser's intent to purchase said consigned item. The foregoing in its entirety is subject to the provision that in no case will the total warranty period extend beyond 18 months from date Seller ships equipment from point of manufacture.

The liability of Seller hereunder is limited to replacing or repairing at Seller's factory or on the job site at Seller's option, any part or parts which have been returned to the Seller and which are defective or do not conform to such specifications, drawings or other written descriptions; provided that such part or parts are returned by the Ultimate Purchaser within ninety (90) days after such defect is discovered. The Seller shall have the sole right to determine if the parts are to be repaired at the job site or whether they are to be returned to the factory for repair or replacement. All items returned to Seller for repair or replacement must be sent freight prepaid to its factory. Purchaser must obtain Seller's Return Goods Authorization prior to returning items. The above conditions must be met if warranty is to be valid. Seller will not be liable for any damage done by unauthorized repair work, unauthorized replacement parts, from any misapplication of the item, or for damage due to accident, abuse, or Act of God.

In no event shall the Seller be liable for loss, damage, or expense directly or indirectly arising from the use of the units, or from any other cause, except as expressly stated in this warranty. Seller makes no warranties, express or implied, including any warranty as to merchantability or fitness for a particular purpose or use. Seller is not liable for and Purchaser waives any right of action it has or may have against Seller for any consequential or special damages arising out of any breach of warranty, and for any damages Purchaser may claim for damage to any property or injury or death to any person arising out of its purchase of the use, operation or maintenance of the product. Seller will not be liable for any labor subcontracted or performed by Purchaser for preparation of warranted item for return to Seller's factory or for preparation work for field repair or replacement. Invoicing of Seller for labor either performed or subcontracted by Purchaser will not be considered as a liability by the Seller.

This warranty shall be exclusive of any and all other warranties express or implied and may be modified only by a writing signed by an officer of the Seller. This warranty shall extend to the Ultimate Purchaser but to no one else. Accessories supplied by Seller, but manufactured by others, carry any warranty the manufacturers have made to Seller and which can be passed on to Ultimate Purchaser.

Seller makes no warranty with respect to whether the products sold hereunder infringe any patent, U.S. or foreign, and Buyer represents that any specially ordered products do not infringe any patent. Buyer agrees to indemnify and hold Seller harmless from any liability by virtue of any patent claims where Buyer has ordered a product conforming to Buyer's specifications, or conforming to Buyer's specific design.

Buyer has not relied and shall not rely on any oral representation regarding the Product sold hereunder and any oral representation shall not bind Seller and shall not be part of any warranty.

There are no warranties which extend beyond the description on the face hereof. In no event shall MGE UPS Systems, Inc. be responsible for consequential damages or for any damages except as expressly stated herein.

## Service and Factory Repair - Call 1 - 800 - 438 - 7373

Direct questions about the operation, repair, or servicing of this equipment to MGE UPS Systems, Inc. Customer Support Services. Include the part number, assembly number, and serial number of the unit in any correspondence. Should you require factory service for your equipment, contact MGE UPS Systems, Inc. Customer Support Services and obtain a Return Goods Authorization (RGA) prior to shipping your unit. Never ship equipment to MGE UPS Systems, Inc. without first obtaining an RGA.

## Proprietary Rights Statement

The information in this manual is the property of MGE UPS Systems, Inc., and represents a proprietary article in which MGE UPS Systems, Inc., retains any and all patent rights, including exclusive rights of use and/or manufacture and/or sale. Possession of this information does not convey any permission to reproduce, print, or manufacture the article or articles shown herein. Such permission may be granted only by specific written authorization, signed by an officer of MGE UPS Systems, Inc.

IBM, PC-AT, ES/9000, and AS/400 are trademarks of International Business Machines Corporation. MGE and MGE UPS Systems are trademarks of MGE UPS Systems, Inc. Other trademarks that may be used herein are owned by their respective companies and are referred to in an editorial fashion only.

---

## Revision History

EPS 6000 Uninterruptible Power System Installation Manual  
86-130034-00  
Copyright © 1996 MGE UPS Systems. All rights reserved. Printed in U.S.A.  
Revision: B00 11/96

---

---

# Contents

---

<b>Section I</b>	<b>Introduction</b>	
1.0 .....	Scope	1 — 1
1.1 .....	General Description	1 — 1
1.2 .....	Description of UPS Module	
	Major Internal Components	1 — 4
1.2.1	Rectifier/Battery Charger	1 — 4
1.2.2	Inverter	1 — 4
1.2.3	Inverter Transformer	1 — 4
1.2.4	Battery System	1 — 4
1.3 .....	Description of SSC	
	Major Internal Components	1 — 5
1.4 .....	Options	1 — 13
1.5 .....	Specifications, UPS Modules	1 — 13
1.5.1	Electrical	1 — 13
1.5.2	Mechanical	1 — 14
1.5.3	Environmental	1 — 15
1.6 .....	Specifications, Static Switch Cabinet	1 — 15
1.6.1	Electrical	1 — 15
1.6.2	Mechanical	1 — 16
1.6.2	Mechanical	1 — 12
<b>Section II</b>	<b>Operation</b>	
2.0 .....	Scope	2 — 1
2.1 .....	System Operation Overview	2 — 1
2.1.1	Static Switch Cabinet Operation	2 — 1
2.1.2	Normal Operation	2 — 2
2.1.3	On-Battery Operation	2 — 2
2.2 .....	Indicators and Controls	2 — 3
2.2.1	Front Panel	2 — 3
2.2.2	Alphanumeric Display and Controls	2 — 6
2.2.3	Hidden Panel	2 — 9
2.2.4	Circuit Breakers, Contactors and Switches	2 — 13
2.3 .....	Using the Alphanumeric Display	2 — 23
2.3.1	Settings	2 — 24
2.3.2	Alarms	2 — 25
2.3.3	Measurements	2 — 26
2.3.3.1	Voltage Measurements	2 — 26
2.3.3.2	Current Measurements	2 — 27
2.3.3.3	Power and Frequency Measurements	2 — 28
2.3.3.4	Battery Measurements	2 — 29

# EPS 6000 UPS Shared Systems

---

section	description	page number
2.4	Normal Operating Procedures	2 — 29
2.4.1	Checks Before Start-up	2 — 29
2.4.2	Start-up	2 — 30
2.4.3	Checks After Start-up	2 — 31
2.4.4	Shut-down	2 — 32
2.4.4.1	Emergency Shutdown Using EPO	2 — 32
2.4.4.2	Normal Shutdown	2 — 33
2.4.5	Isolation for Maintenance	2 — 33
2.4.5.1	Isolation of an Individual UPS Module	2 — 33
2.4.5.2	Isolation of Static Switch Cabinet (SSC)	2 — 35
2.4.5.2.1	Without Maintenance Bypass	2 — 35
2.4.5.2.2	With Maintenance Bypass	2 — 35
2.4.6	Forced Transfers	2 — 36
2.4.6.1	Uninterrupted Transfer Conditions	2 — 36
2.4.6.2	Forced Transfer From Bypass AC Input Source to Inverter	2 — 37
2.4.6.3	Forced UPS Module Shut Down	2 — 37
2.5	LCD Messages	2 — 37

## **Section III Maintenance and Service**

3.0	Scope	3 — 1
3.1	Safety Instructions	3 — 1
3.2	Preventive Maintenance	3 — 1
3.3	Replacement Parts	3 — 2
3.4	Troubleshooting and MGE Servicing	3 — 3

<b>Glossary</b>	g — 1
-----------------	-------

## Illustrations

figure	description	page number
1-1	Pictorial, Typical EPS 6000 UPS Shared Installation (Shown With Two 375 kVA UPS Modules)	1 — 3
1-2	Single-Line Diagram, Typical EPS 6000 UPS Shared Installation	1 — 3
1-3	EPS 6000 Major Internal Components, Shared 150 - 225 kVA UPS Modules	1 — 5
1-4	EPS 6000 Major Internal Components, Shared 375 kVA UPS Modules	1 — 6
1-5	EPS 6000 Major Internal Components, Shared 500 kVA UPS I/O Cabinet	1 — 7
1-6	EPS 6000 Major Internal Components, Shared 500 kVA UPS Cabinet	1 — 8
1-7	EPS 6000 Major Internal Components, Shared 750 kVA UPS Cabinet 1	1 — 9
1-8	EPS 6000 Major Internal Components, Shared 750 kVA UPS Cabinet 2	1 — 10
1-9	EPS 6000 Major Internal Components, Shared 750 kVA UPS Cabinet 3	1 — 11
1-10	EPS 6000 Major Internal Components, Static Switch Cabinet (SSC)	1 — 12
2-1	Power Flow, Normal Operation	2 — 1
2-2	Power Flow, On-Battery Operation	2 — 2
2-3	Power Flow, Bypass Operation	2 — 3
2-4	EPS 6000 Controls and Indicators	2 — 4
2-5	EPS 6000 Front Panel	2 — 4
2-6	Alphanumeric Display and Controls	2 — 7
2-7	Hidden Panel	2 — 9
2-8	Hidden Panel Pushbuttons	2 — 12

# EPS 6000 UPS Shared Systems

---

2-9	Single-Line Diagram, Typical EPS 6000 UPS Shared Installation	2 — 14
2-10	EPS 6000 Major Internal Components, Shared 150 - 225 kVA UPS Module	2 — 15
2-11	EPS 6000 Major Internal Components, Shared 300 / 375 kVA UPS Module	2 — 16
2-12	EPS 6000 Major Internal Components, Shared 500 kVA UPS Module I/O Cabinet	2 — 17
2-13	EPS 6000 Major Internal Components, Shared 500 kVA UPS Module UPS Cabinet	2 — 18
2-14	EPS 6000 Major Internal Components, Shared 750 kVA UPS Module UPS Cabinet 1	2 — 19
2-15	EPS 6000 Major Internal Components, Shared 750 kVA UPS Module UPS Cabinet 2	2 — 20
2-16	EPS 6000 Major Internal Components, Shared 750 kVA UPS Module UPS Cabinet 3	2 — 21
2-17	EPS 6000 Major Internal Components, Static Switch Cabinet (SSC)	2 — 22
2-18	Alphanumeric Display	2 — 23
2-19	General Display Configuration	2 — 24
2-20	Display Settings Display	2 — 24
2-21	Displaying Alarm Messages	2 — 25
2-22	Voltage Measurements	2 — 26
2-23	Current Measurements	2 — 27
2-24	Power and Frequency Measurements	2 — 28
2-25	Battery Measurements	2 — 29



**Tables**

table	description	page number
1-1 . . . . .	EPS 6000 Model Numbers, Shared System UPS Modules	1 — 2
1-2 . . . . .	EPS 6000 Model Numbers, Static Switch Cabinets (SSC)	1 — 2

## How to use this manual

This manual is designed for ease of use and easy location of information.

To quickly find the meaning of terms used within the text, look in the Glossary.

This manual uses Noteboxes to convey important information. Noteboxes come in four varieties:



**WARNING**

A **WARNING** notebox indicates information provided to protect the user and service personnel against safety hazards and/or possible equipment damage.



**CAUTION**

A **CAUTION** notebox indicates information provided to protect the user and service personnel against possible equipment damage.



**IMPORTANT**

An **IMPORTANT** notebox indicates information provided as an operating instruction, or as an operating tip.



**NOTE**

A **NOTE** notebox indicates information provided as an operating tip or an equipment feature.

---

# Introduction

---

## 1.0 Scope

This manual provides technical information required for operation and maintenance of the shared EPS 6000 uninterruptible power system (UPS). Please read this manual before operating the EPS 6000 equipment. Please retain this manual for future reference.

The manual is divided into three sections:

### Section I — General Description

This section introduces the EPS 6000 family of uninterruptible power systems, including a general description of the system and its internal components, a description of available options, and system specifications.

### Section II — Operation

This section describes operating information for EPS 6000 UPS shared systems, including an overview of the system, its components, and their function; a description of the indicators and controls and their function; and operational sequences to be followed for all conditions of normal, emergency, and maintenance operation.

### Section III — Maintenance and Service

This section describes maintenance of the EPS 6000 UPS, including safety instructions, preventive maintenance, information about replacement parts, and customer service.

A Glossary in the rear of this manual provides definitions of terms used within the text. A separate manual, EPS 6000 UPS Installation Manual (MGE part number 86-130035-00) provides detailed installation instructions.

## 1.1 General Description

EPS 6000 is a family of compact, high-efficiency uninterruptible power systems, available in power ratings up to 1,500 kVA. EPS 6000 UPS are optimized for compatibility with non-linear computer-type loads. Computer-aided UPS diagnostics and modular construction assures that any required service on the UPS can be identified and completed rapidly. Remote system monitoring, remote annunciation of UPS performance signals, and telecommunication capabilities allow total control of the UPS by the user.

The EPS 6000 UPS, SSC, battery, and all auxiliary equipment is listed for safety by Underwriter's Laboratories, Inc. (UL) under UL Standard 1778; and under Canadian Standards Association (CSA) standard C22.107.

Major components of the EPS 6000 UPS family include:

- EPS 6000 UPS module
- EPS 6000 SSC static switch cabinet
- EPS 6000 SSC maintenance bypass cabinet
- EPS 6000 auxiliary cabinet

## EPS 6000 UPS Shared Systems

---

- EPS 6000 battery cabinet

Each of these cabinets is described below. Figure 1-1 shows a typical shared UPS installation, consisting of one static switch cabinet (SSC), two UPS modules, and two adjacent battery cabinets. Figure 1-2 shows a single-line diagram of the same shared UPS installation. Table 1-1 identifies EPS 6000 UPS model numbers for modules used in shared systems, and Table 1-2 identifies EPS 6000 SSC model numbers.

**Table 1-1 EPS 6000 Model Numbers, Shared System UPS Modules**

MODEL NUMBER	INPUT VOLTAGE (VAC)	OUTPUT VOLTAGE (VAC)	OUTPUT RATING (kVA/kW)	INPUT CB (Amps)	TOTAL WIDTH (mm/in)	TOTAL WEIGHT (kg/lb)	HEAT LOSS (Btu/hr)
EPS-6150/44,66P	480	480	150/120	400	2,010/81.5	2,044/4,508	30,818
EPS-6225/44,66P	480	480	225/180	400	2,010/81.5	2,044/4,508	39,202
EPS-6300/44,66P	480	480	300/240	600	2,010/81.5	2,514/5,543	52,269
EPS-6375/44,66P	480	480	375/300	700	2,010/81.5	2,545/5,612	65,336
EPS-6500/44,66P	480	480	500/400	1000	2,865/113	4,244/7,211	79,453
EPS-6750/44,66P	480	480	750/600	1600	4,900/195	6,000/13,200	131,000

**NOTES:**

1. Total width, weight, and heat loss are for system line-up including auxiliary cabinets but excluding pallets.
2. Data does not include battery data; refer to the installation drawings supplied with your equipment.
3. Information provided is for standard configurations; data may change with optional equipment. Consult the installation drawings provided with your equipment.

**Table 1-2 EPS 6000 Model Numbers, Static Switch Cabinets (SSC)**

MODEL NUMBER	INPUT VOLTAGE (VAC)	OUTPUT VOLTAGE (VAC)	OUTPUT RATING kVA/kW	INPUT CB (Amperes)	TOTAL WIDTH (mm/in)	TOTAL WEIGHT (kg/lb)	HEAT LOSS (Btu/hr)
SSC1500	480	480	1500/1200	2000	1829/72	1317/2900	(Negligible)

Figure Pictorial, Typical EPS 6000 UPS Shared Installation  
1-1 (Shown With Two 375 kVA UPS Modules)

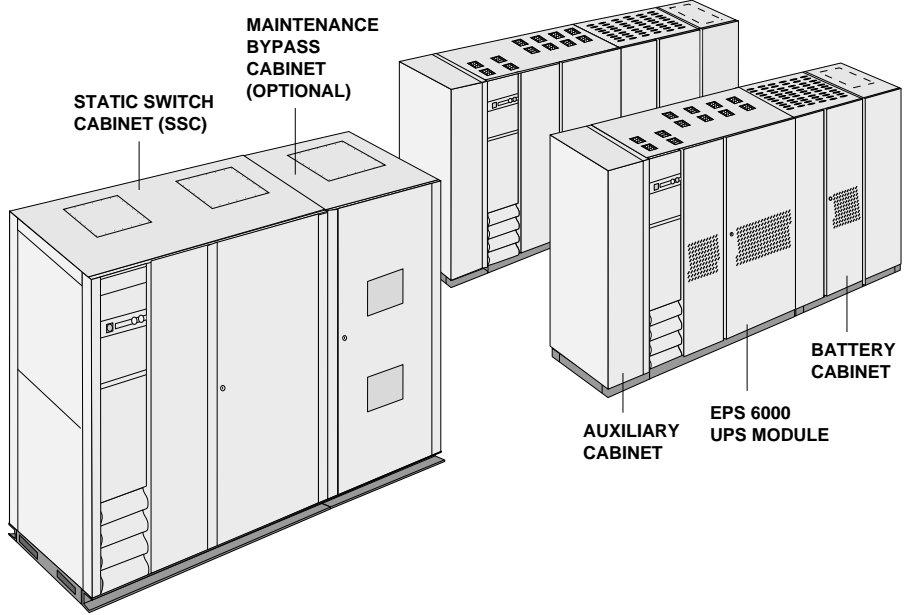
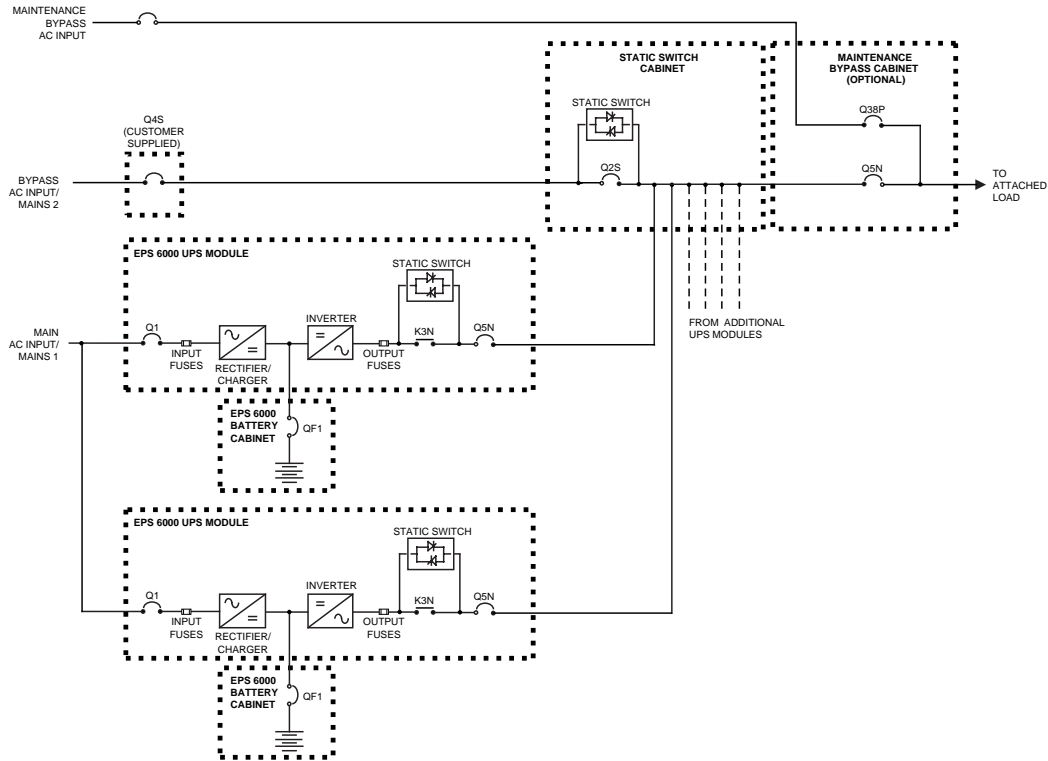

Figure Single-Line Diagram, Typical EPS 6000 UPS Shared Installation  
1-2



- 1.2 Description of UPS Module Major Internal Components** Following is a description of the EPS 6000 UPS major internal components. Refer to the single-line diagram provided in Figure 1-2, and the component locators provided in Figure 1-3 through Figure 1-10
- 1.2.1 Rectifier/Battery Charger** The rectifier/battery charger converts the AC input voltage from the utility source into a DC voltage, supplying the inverter and regulating the charge of the battery system. A capacitor bank filters the DC voltage.
- 1.2.2 Inverter** The inverter chops the DC voltage supplied from either the rectifier/battery charger or the battery system into a three-phase AC voltage. An AC output filter is used to achieve a computer-grade sinewave output voltage waveform, with a total harmonic distortion of less than 2% under linear-load conditions.
- 1.2.3 Inverter Transformer** During normal operation, the inverter transformer provides complete electrical isolation between the UPS output to the attached load and the utility power source input as well as the UPS battery source.
- 1.2.4 Battery System** The battery system stores energy for use by the inverter. The stored energy is utilized in the event that the AC input power from the utility source fails, or falls outside of acceptable tolerance.

The battery system may be an MGE battery cabinet designed for operation with the EPS 6000 UPS, or a customer-supplied battery installation.

MGE-supplied EPS 6000 battery cabinets may be provided as stand-alone enclosures, or as enclosures designed to be mounted adjacent to the EPS 6000 UPS module.

The EPS 6000 comes with a special battery ambient temperature sensor which allows the optimization of the DC voltage level as a function of the temperature, ensuring that the battery is properly charged and preserving its longevity.

### 1.3 Description of SSC Major Internal Components

The static switch cabinet (SSC) provides an electrical path between the output of the UPS modules and the load. When the UPS modules are off, the SSC provides power to the load from the bypass AC input source (mains 2). Up to six (6) modules can be connected to the SSC, supporting loads as great as 1,500 kVA. UPS modules may be turned off individually for maintenance, provided that the remaining modules can support the load.

The SSC incorporates a static bypass switch. A wrap-around circuit breaker (Q2S) in the SSC switches between the UPS module output and the bypass AC input source (when the UPS modules are off). Optionally, the SSC can be provided with its own maintenance bypass cabinet (MBC), allowing the SSC and/or any attached UPS module to be serviced while the load is supplied via the maintenance bypass AC input source.

Figure 1-3 EPS 6000 Major Internal Components, Shared 150 - 225 kVA UPS Modules

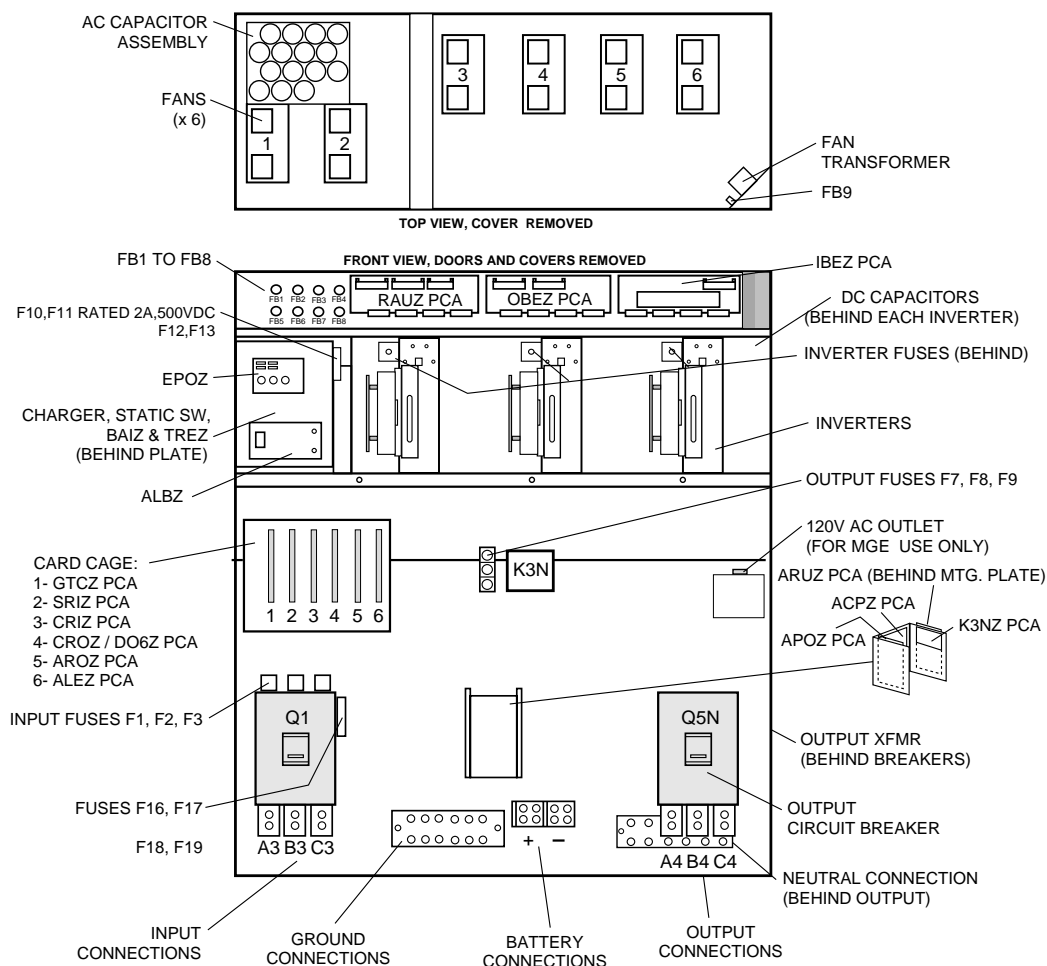

# EPS 6000 UPS Shared Systems

Figure EPS 6000 Major Internal Components,  
1-4 Shared 375 kVA UPS Modules

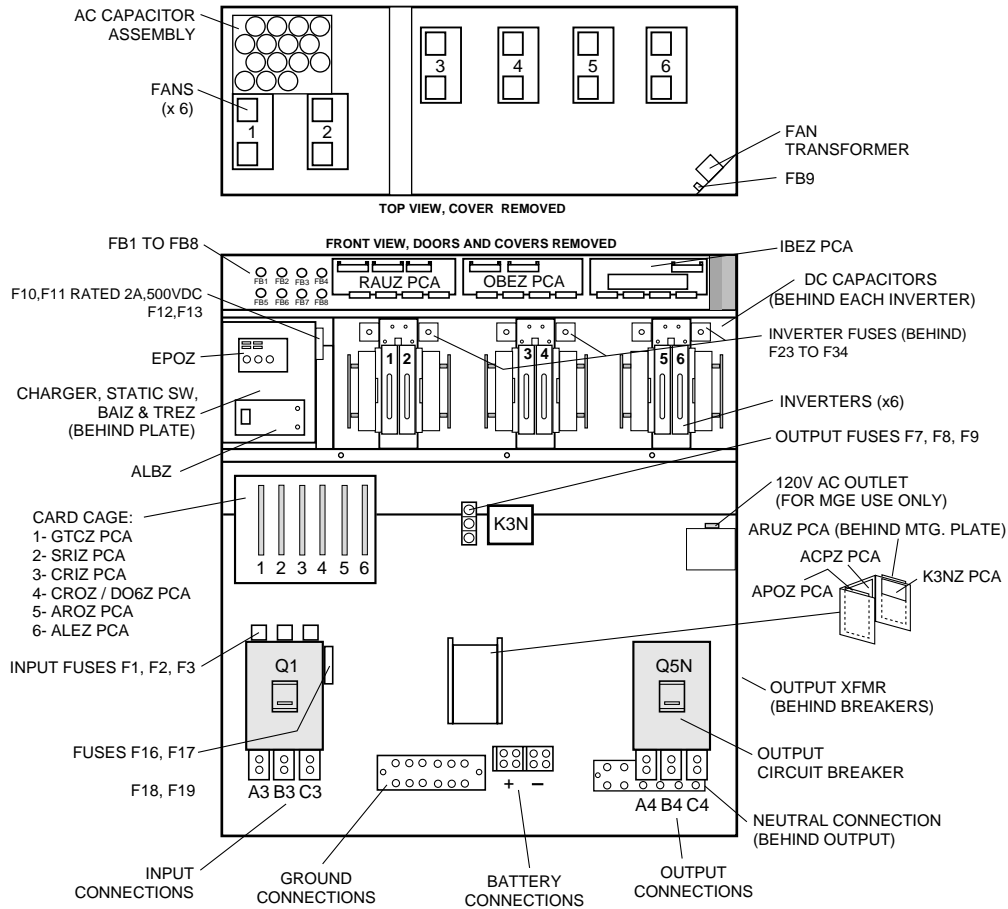
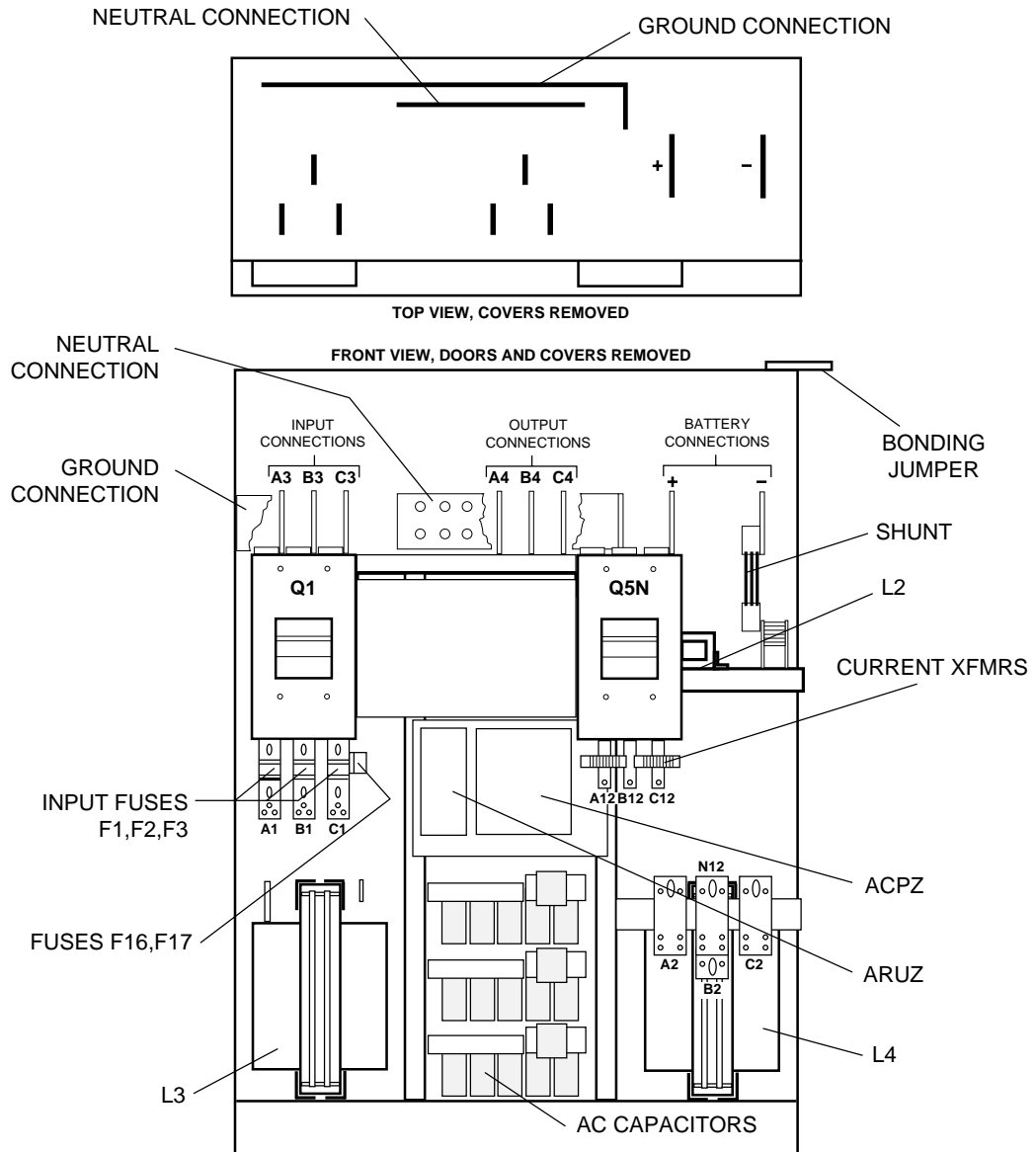



Figure EPS 6000 Major Internal Components,  
1-5 Shared 500 kVA UPS I/O Cabinet



# EPS 6000 UPS Shared Systems

Figure EPS 6000 Major Internal Components,  
1-6 Shared 500 kVA UPS Cabinet

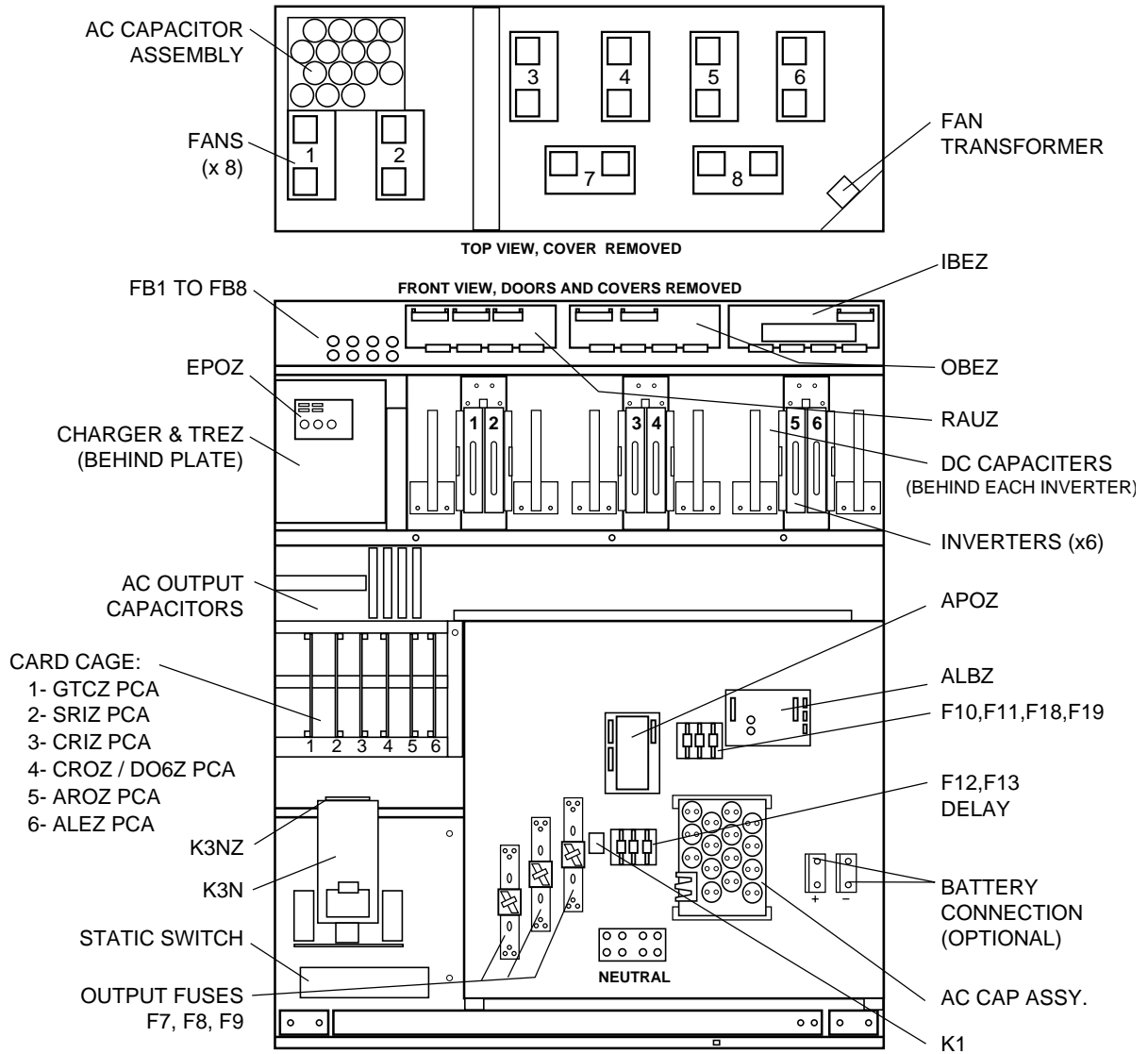
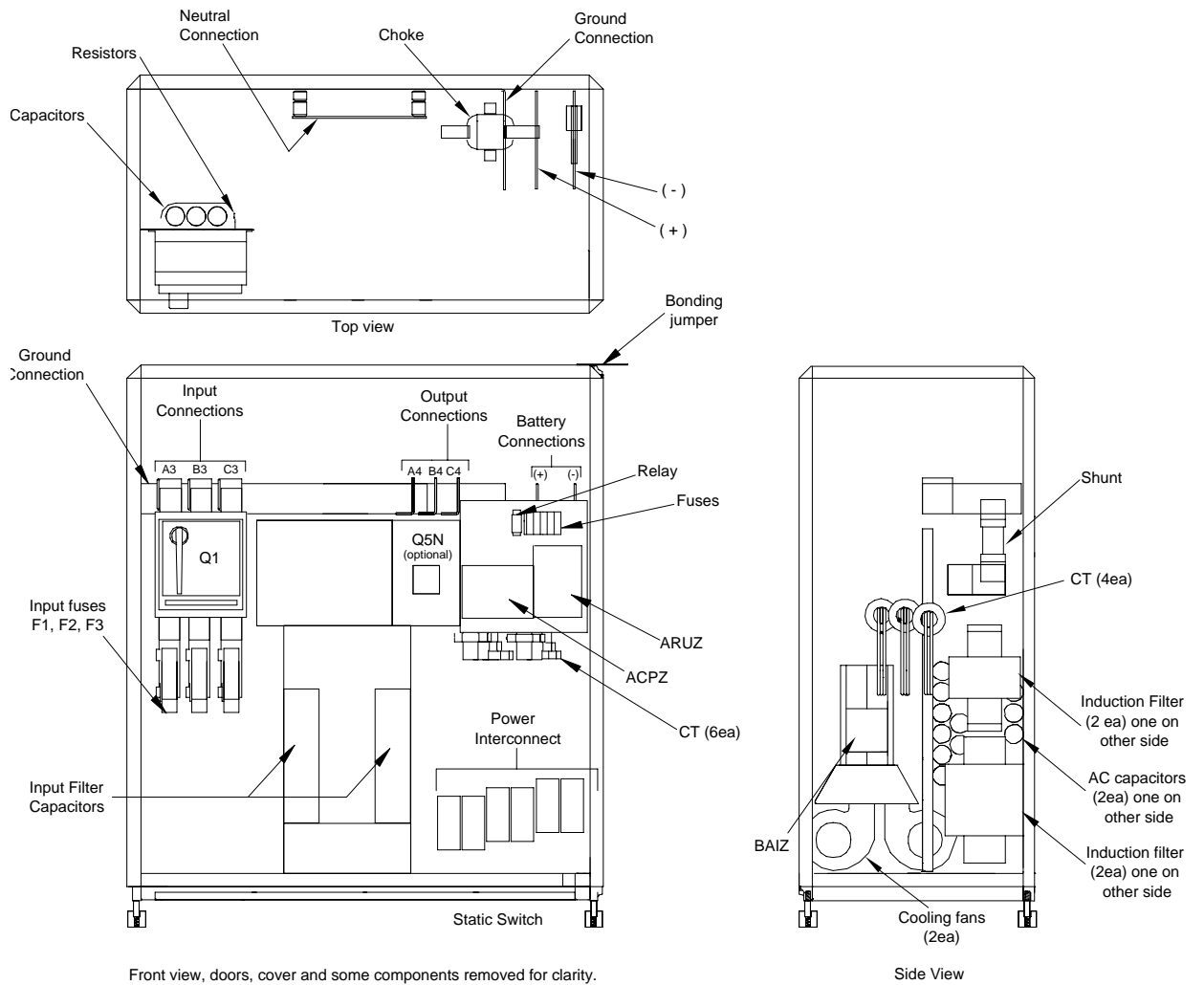

Figure EPS 6000 Major Internal Components,  
1-7 Shared 750 kVA UPS Cabinet 1



# EPS 6000 UPS Shared Systems

Figure EPS 6000 Major Internal Components,  
1-8 Shared 750 kVA UPS Cabinet 2

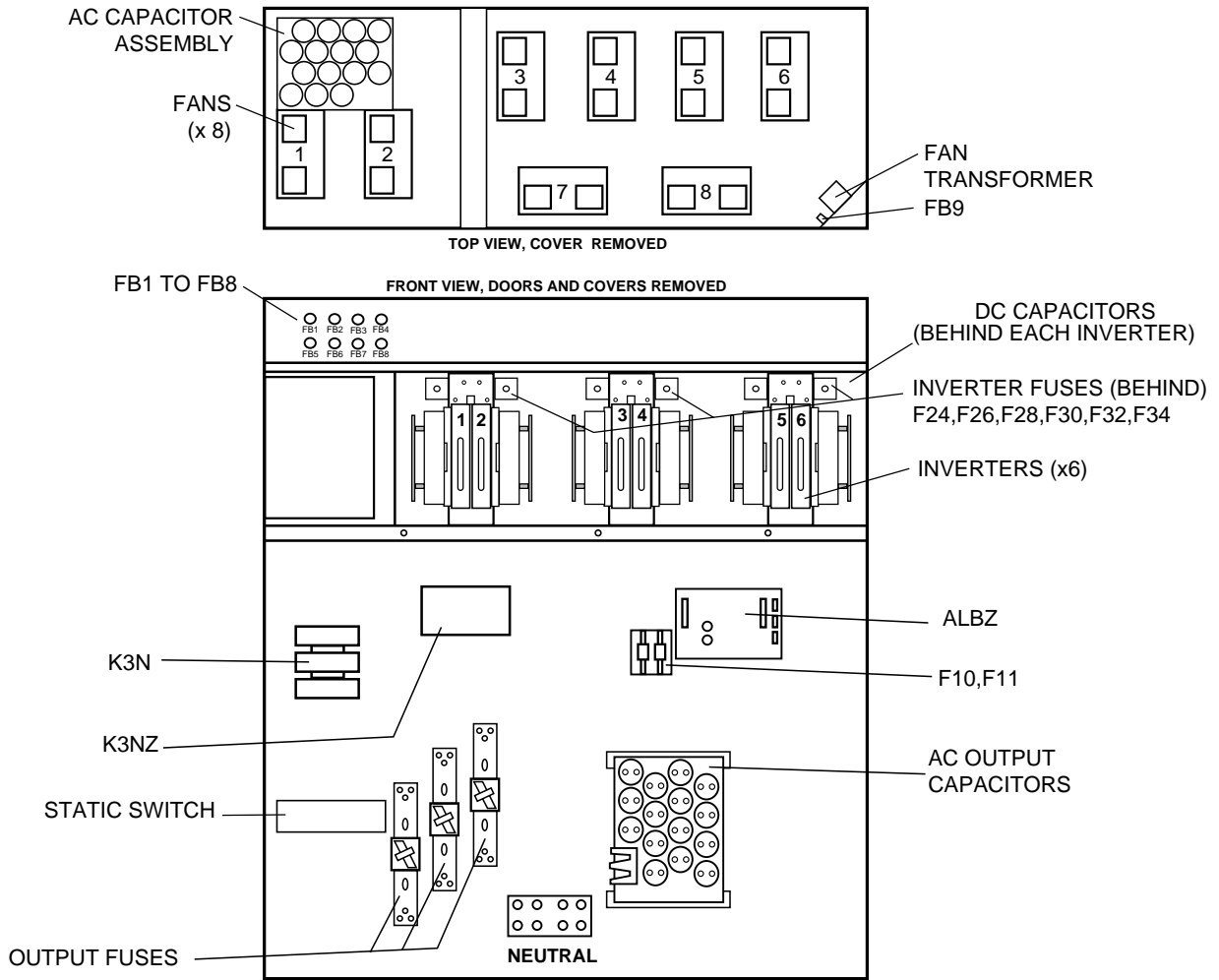
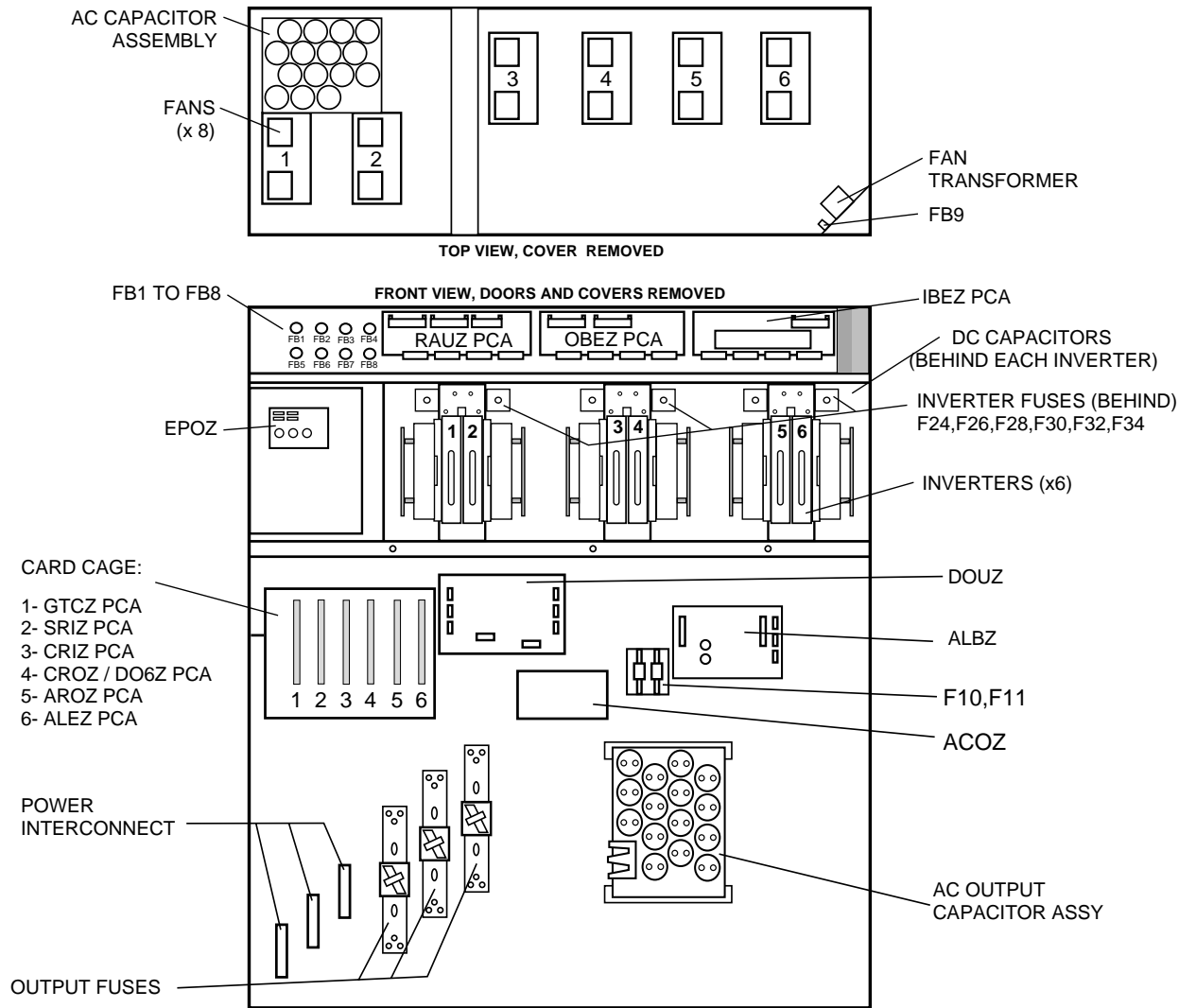

Figure EPS 6000 Major Internal Components,

1-9 Shared 750 kVA UPS Cabinet 3



# EPS 6000 UPS Shared Systems

Figure EPS 6000 Major Internal Components,  
1-10 Static Switch Cabinet (SSC)

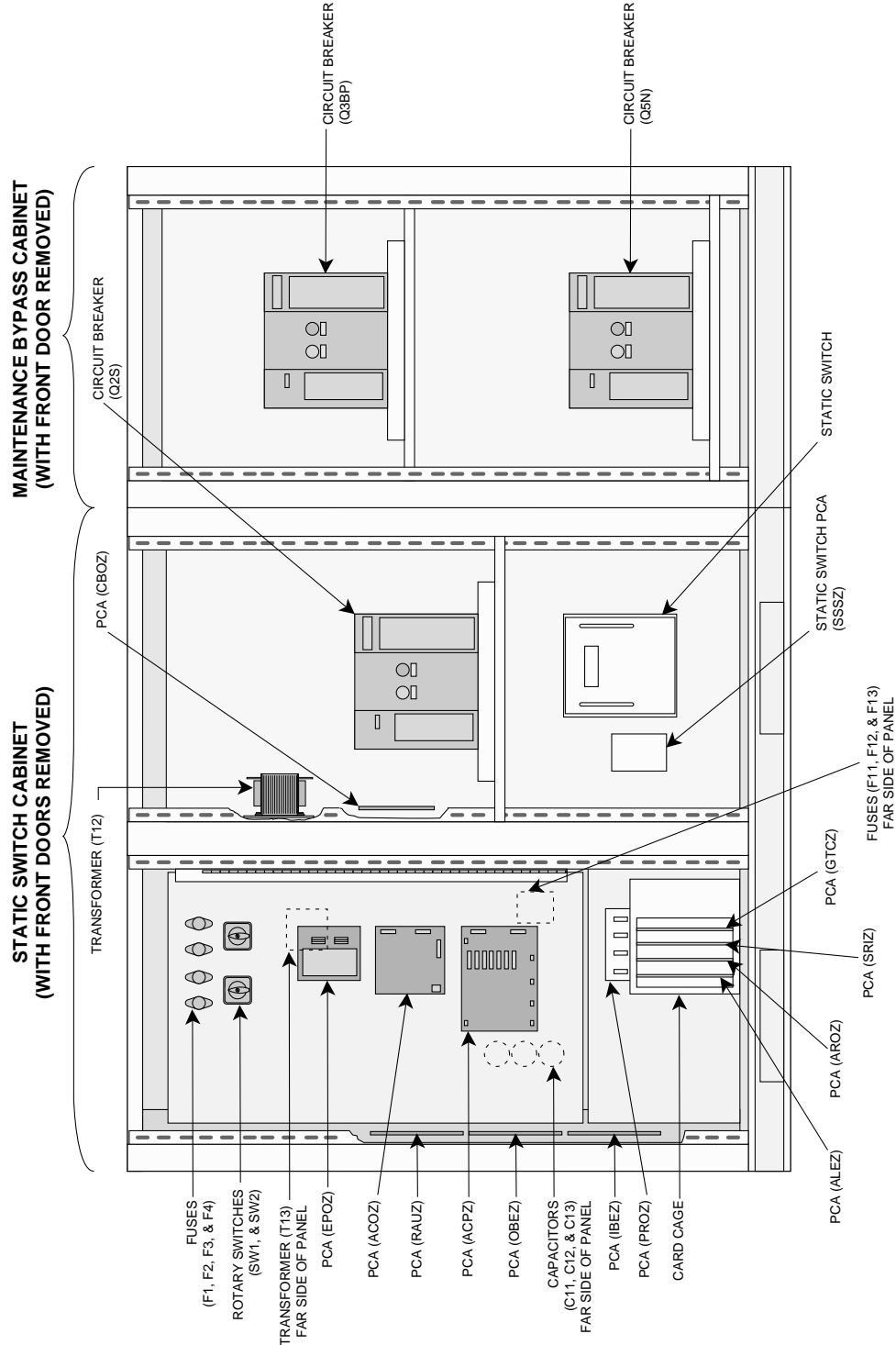

## 1.4 Options

This section describes options available for the EPS 6000 UPS. Some configurations do not support some options.

Most options must be specified at the time of equipment order; some options can be installed in the field. Contact your MGE dealer for complete information.

### Additional battery cabinets

Up to a maximum of four battery cabinets can be supplied for a single EPS 6000 UPS module, making additional back-up time available during power outages.

### Input filter

An input harmonic current filter is available for the EPS 6000 UPS. For some power levels, the input filter is installed within the UPS enclosure. For others, the input filter is installed in an auxiliary cabinet.

### High interrupting capacity circuit breakers

The EPS 6000 UPS module is normally equipped with circuit breakers rated at 30 kAIC. As an option, these breakers can be provided with a rating of 65 kAIC.

### Maintenance bypass

For the UPS modules, maintenance bypass is provided by the SSC, allowing any or all attached UPS modules to be taken off-line while the SSC supports the attached load from its bypass source. As an option, the SSC can be equipped with its own maintenance bypass, allowing the SSC as well as any/all attached UPS modules to be serviced while the load is supported by the maintenance bypass AC input source.

### Active RS-232/RS-485

A communications port is available that allows the UPS module or the SSC to be monitored from a remote terminal or computer. For detailed information on the communication features, contact your MGE dealer.

## 1.5 Specifications, UPS Modules

Specifications provided refer to an EPS 6000 UPS module and any required auxiliary cabinets.

### 1.5.1 Electrical

#### AC input ratings

Voltage: 208 or 480 VAC, +10%, -15%  
 Frequency: 60 Hz,  $\pm$  10%  
 Phases: 3  $\emptyset$  (phase sequence must be A, B, C)  
 Wires: 3 or 4 wires plus ground  
 Current:

rating in kVA	150	225	300	375	500	750
Amperes @ 480 VAC	200	300	400	490	702	980

Power factor: Up to 0.9 lagging; 0.95 with optional input harmonic filter

# EPS 6000 UPS Shared Systems

---

## AC output ratings

Voltage:	480 VAC $\pm$ 0.5% (steady-state conditions) 480 VAC $\pm$ 5% (transient conditions from 0% to 100% or 100% to 0%)
Frequency:	60 Hz $\pm$ 0.1% (free-running)
Phases:	3 $\emptyset$ (phase sequence must be A, B, C)
Wires:	4 wires plus ground
Current:	

rating in kVA	150	225	300	375	500	750
Amperes @ 480 VAC	180	271	361	451	601	902

Power factor:	0.8 lagging
Total harmonic distortion (THD):	< 2% (linear load) < 4% (for 100% non-linear load with a crest factor of up to 3.5)
Dynamic regulation:	$\pm$ 0.5% for balanced load $\pm$ 2.5% for 100% unbalanced load
Dynamic response:	$\pm$ 5% for 100% step load change
Overload:	125% of rated load for 10 minutes 150% of rated load for 1 minute

## DC ratings

Battery voltage:	545 Vdc float 480 Vdc nominal 390 Vdc minimum
------------------	---

rating in kVA	150	225	300	375	500	750
Maximum battery current at cut-off voltage (ADC)	323	485	647	809	1,074	1,620

## 1.5.2 Mechanical

Height:	1,905 mm (75")
Depth:	815 mm (32")
Width:	See Table 1-1
Weight:	See Table 1-1
Finish:	MGE light gray



### 1.5.3 Environmental

Recommended environment: 20° to 25° C (68° to 77° F.); 50% relative humidity; computer room or other temperature- and humidity-controlled environment

Operating temperature: 0° to 40° C (32° to 104° F.) except battery

Storage: -20° to 50° C (-4° to 122° F.)

Humidity: up to 90% non-condensing (operating)

Altitude: sea level to 1,000 meters (sea level to 3,280 feet) without derating; 1,000 to 2,000 meters (3,280 to 6,560 feet): derate operating temperature to a maximum of 28° C (82° F)

Acoustic noise:

rating in kVA	150	225	300	375	500	750
Acoustic noise at rated load in dBA at 5 feet from the front of the UPS module	72	72	72	72	75	78

## 1.6 Specifications, Static Switch Cabinet

### 1.6.1 Electrical

#### AC input ratings

Voltage: 480 VAC, ± 15%

Frequency: 60 Hz, ± 10%

Phases: 3 Ø (phase sequence must be A, B, C)

Wires: 3 or 4 wires plus ground

Current: 2,000 Amperes

#### AC output ratings

Voltage: 480 VAC

Frequency: 60 Hz

Phases: 3 Ø

Wires: 4 wires plus ground

Current: 2,000 Amperes

Power factor: 0.8 lagging

### 1.6.2 Mechanical

Height:	1,981 mm/78 in.
Depth:	1,219 mm/48 in.
Width:	1,829 mm/72 in.
Weight:	1,310 kg/2,900 lbs. (SSC) 1,091 kg/2,000 lbs. (MBC)
Finish:	MGE light gray

# Operation

**2.0 Scope** This section presents operating information for EPS 6000 UPS shared systems, including an overview of the system, its components, and their function; a description of the indicators and controls and their function; and operational sequences to be followed for all conditions of normal, emergency, and maintenance operation.

**2.1 System Operation Overview** This section presents an overview of system operation.

**2.1.1 Static Switch Cabinet Operation** During normal operation (as shown in Figure 2-1), and on-battery operation (shown in Figure 2-2), the attached load is supplied by the UPS modules through the SSC. The SSC maintains synchronization of the UPS modules, and monitors their proper performance.

If all UPS modules have stopped, for instance during an overload condition or maintenance, the attached load is supplied by the SSC's bypass input source.

If the SSC is equipped with the maintenance bypass option, the load may still be supplied with power while the SSC is serviced, via the maintenance bypass AC input source.

Figure 2-1 Power Flow, Normal Operation

2-1

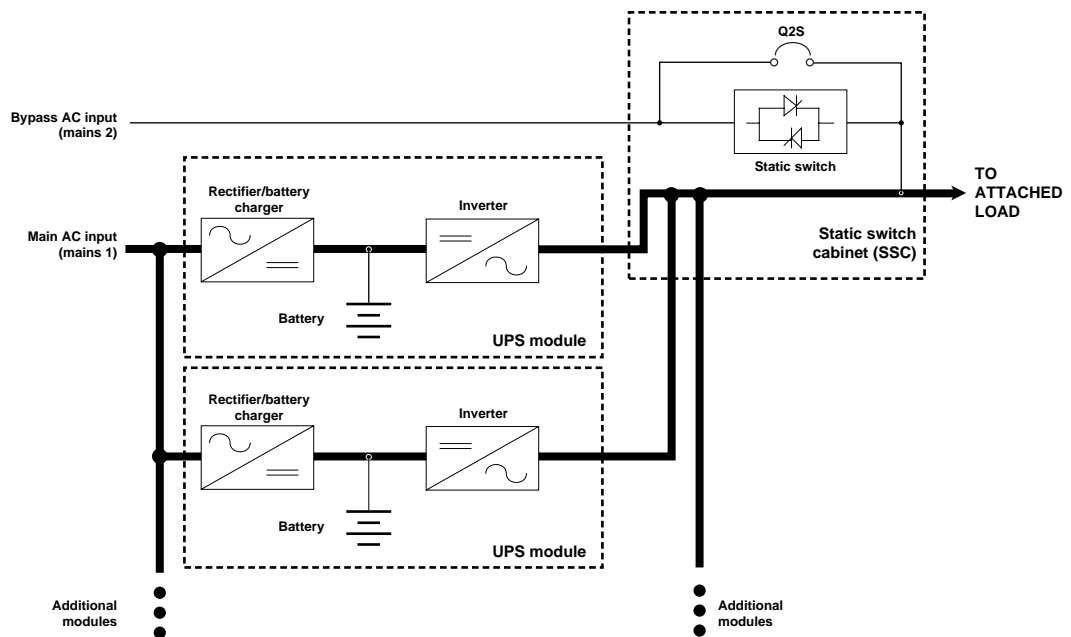

# EPS 6000 UPS Shared Systems

## 2.1.2 Normal Operation

During normal operation (as shown in Figure 2-1), power flows from the main AC input source (mains 1) into the UPS rectifier/battery charger sections. The rectifier/battery chargers convert the AC voltage to DC, maintain the charge on the batteries, and feed the DC power to the inverters. The inverters regenerate AC voltage, and supply the SSC's UPS module AC output bus. The SSC supplies the attached load.

## 2.1.3 On-Battery Operation

If the main AC input source (mains 1) fails or goes out of tolerance, the chargers stop. Power flows from the batteries to the UPS inverters, which in turn supply the attached load (as shown in Figure 2-2). When the main AC input source (mains 1) returns, the chargers restart automatically and the UPS system resumes its normal operation (as shown in Figure 2-1).

If the batteries become depleted before the main AC input source (mains 1) returns, the inverters stop and the attached load is transferred to the bypass AC input source (mains 2) if it is available (as shown in Figure 2-3).

Figure Power Flow, On-Battery Operation

2-2

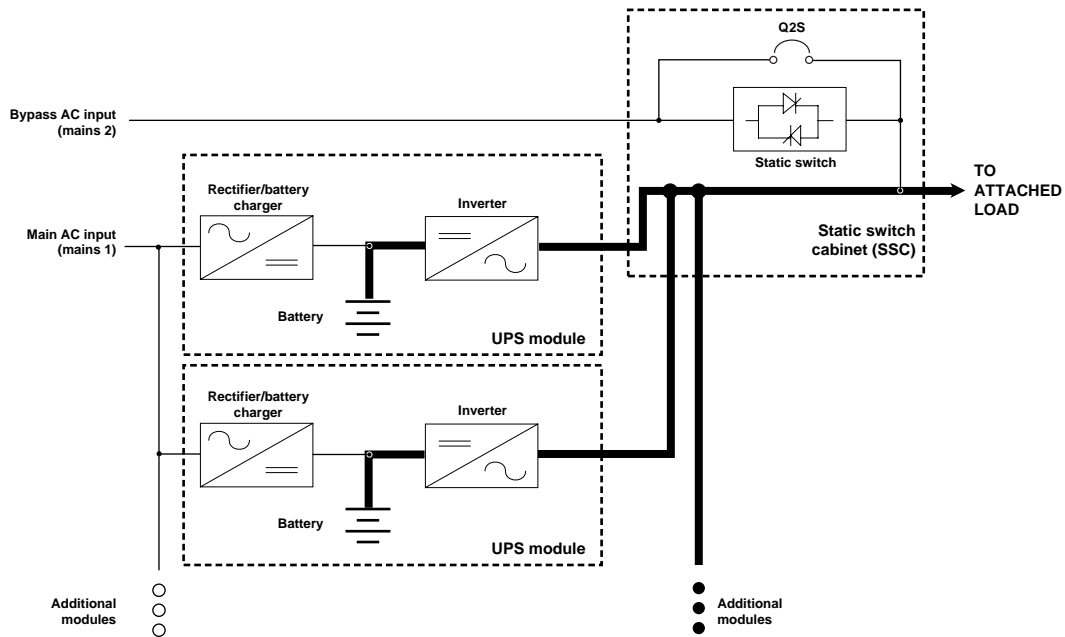
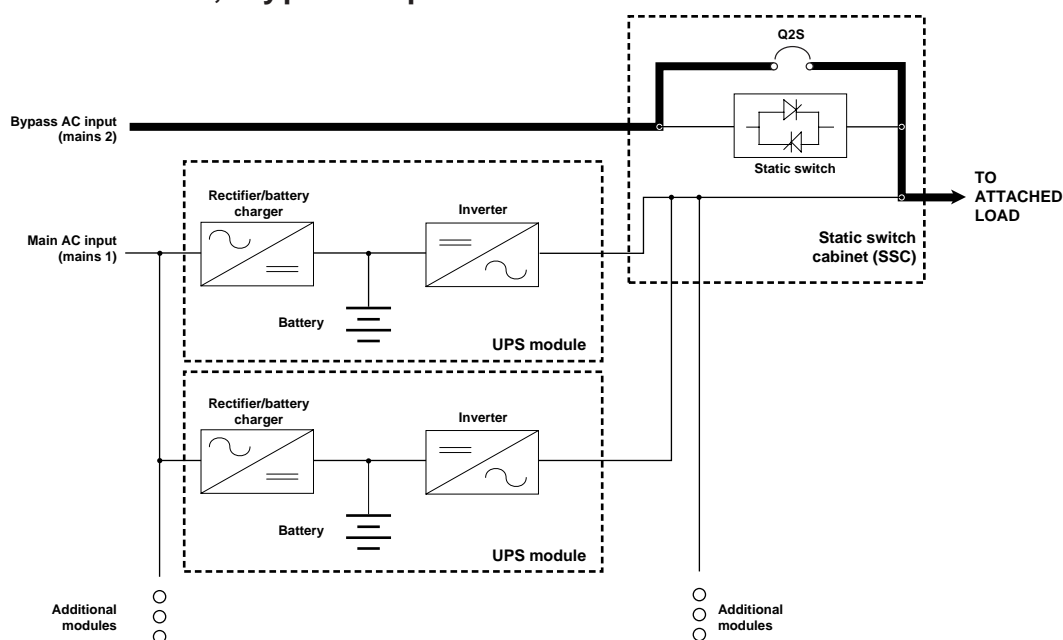

Figure Power Flow, Bypass Operation

2-3



## 2.2 Indicators and Controls

Indicators and controls are located in three places on the UPS module: on the front panel, behind a drop-down cover just below the front panel, and inside the enclosure doors, as shown in Figure 2-4. In battery cabinets and auxiliary cabinets, the controls are located behind the cabinet doors.

### 2.2.1 Front Panel

The front panel, shown in Figure 2-5, includes the emergency power off (EPO) pushbutton, the audible alarm, four LEDs that serve as system status indicators (three on the SSC), and the “inverter on” and “inverter off” pushbuttons (on UPS modules only).

# EPS 6000 UPS Shared Systems

Figure EPS 6000 Controls and Indicators

2-4

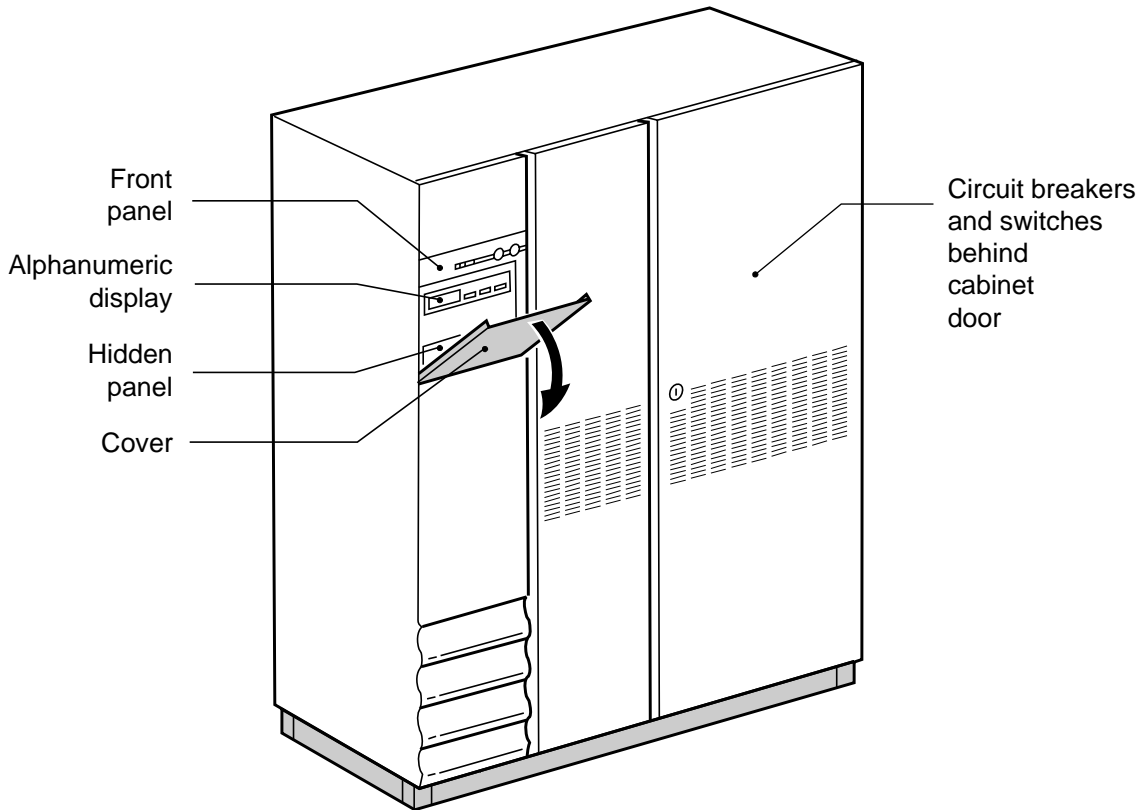
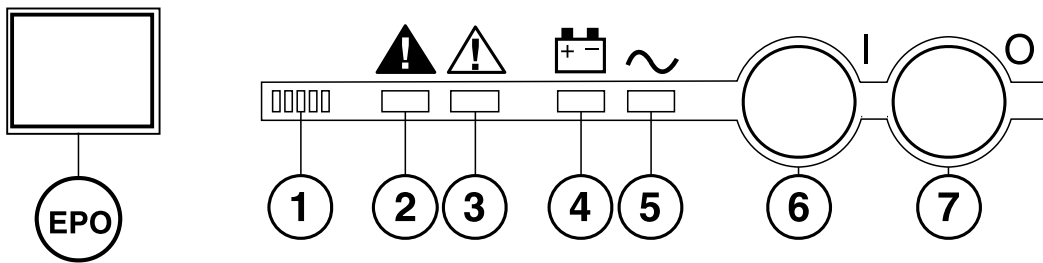

Figure EPS 6000 Front Panel

2-5



Note: The SSC does not include inverter on or inverter off pushbuttons #6 and #7, or the battery operation LED #4.

## Emergency power off (EPO)

**CAUTION**

**Pressing the EPO disconnects the attached load. The emergency power off (EPO) is to be used during emergency situations only, where a hazard to personnel or equipment exists, such as during a fire. DO NOT USE THE EPO TO TURN THE UPS ON OR OFF; follow the procedures listed in this section for turning on and off the inverter.**

On the left side of the front panel, an emergency power off (EPO) pushbutton is provided, with a protective cover to guard against inadvertent operation. This pushbutton, when activated on a UPS module, disconnects the main AC input (mains 1), and battery power to the module, and disconnects output power to the SSC's UPS module AC input bus. When activated on the SSC, it sends a shunt trip signal to the upstream protective device (Q4S) supplying the bypass AC input (mains 2) source, and sends an EPO command to each UPS module (see above), disconnecting the attached load.

**Audible alarm (Figure 2-5, item 1)**

The audible alarm provides an audible warning to the operator by sounding a pulsed "beep" when any of the following conditions occur:

- Load transferred to bypass (mains 2)
- Load supplied via battery
- Operating problem

During minor alarm conditions, the alarm sounds at a slow rate and a low sound level. When the battery approaches the low-voltage shutdown level, the alarm sounds louder and at an increased rate. If the inverter shuts down, the alarm sounds loudly and continuously.

An audible alarm reset is located on the hidden panel (see Figure 2-7). Pressing it will silence the alarm. Should a higher-level alarm condition occur after the reset has been activated, the audible alarm will sound the new alarm condition.

**Load not protected LED (2)**

This red LED turns on when any of these conditions occur:

- The load is no longer protected following an inverter shutdown, or the opening of the isolation circuit breaker (Q5N)
- The battery circuit breaker QF1 is open, making battery power unavailable



### Operating problem LED (3)

This orange LED turns on when an operating problem exists, such as fan failure; static switch power supply fault; battery temperature fault; overload fault; or bypass AC input (mains 2) out of tolerance. The UPS continues to protect the attached load.



### Battery operation LED (4) (UPS modules only)

This orange LED turns on to indicate that the attached load is being partially or completely supplied by the battery. When the main AC input (mains 1) fails or is outside tolerance, stored battery energy is supplied to the inverter, which in turn supplies the load.



### Load protected LED (5)

This green LED indicates that the attached load is supplied by the inverter and protected by the battery. During normal operation, this LED is the only one that is on.

### Inverter on (6) (UPS modules only)

This green pushbutton is used to start the inverter. When it is pushed, the green “load protected” LED flashes for three seconds, indicating that the start command has been received. When the transfer conditions are satisfied (see Section 2.4.2, Start-up, and Section 2.4.6, Forced Transfers), the load is transferred to the inverter output.

### Inverter off (7) (UPS modules only)

This gray pushbutton is used to stop the inverter. When it is pressed for 3 seconds, the inverter stops and the UPS module is shut down; if all UPS modules are stopped, the load is transferred to the bypass AC input (mains 2) power source. If the uninterrupted transfer conditions are not met, this pushbutton has no effect and the inverter can be stopped only from the hidden panel (see Section 2.4.6, Forced Transfers). See Section 2.4.2 for details of the shutdown sequence.

## 2.2.2 Alphanumeric Display and Controls

The alphanumeric display is located on the hidden panel, directly below the front panel, behind the hinged cover, as shown in Figure 2-4. For complete instructions, refer to Section 2.3, Using the Alphanumeric Display. A brief description of the display and controls follows:

### Two-line alphanumeric display (Figure 2-6)

This 40-character, two line LCD displays general status of the UPS continuously, and displays measurements of UPS operating parameters as selected with the control pushbuttons.



**Pushbuttons**

Following are brief descriptions of the function of the alphanumeric display pushbuttons.

Figure 2-6 **Alphanumeric Display and Controls**

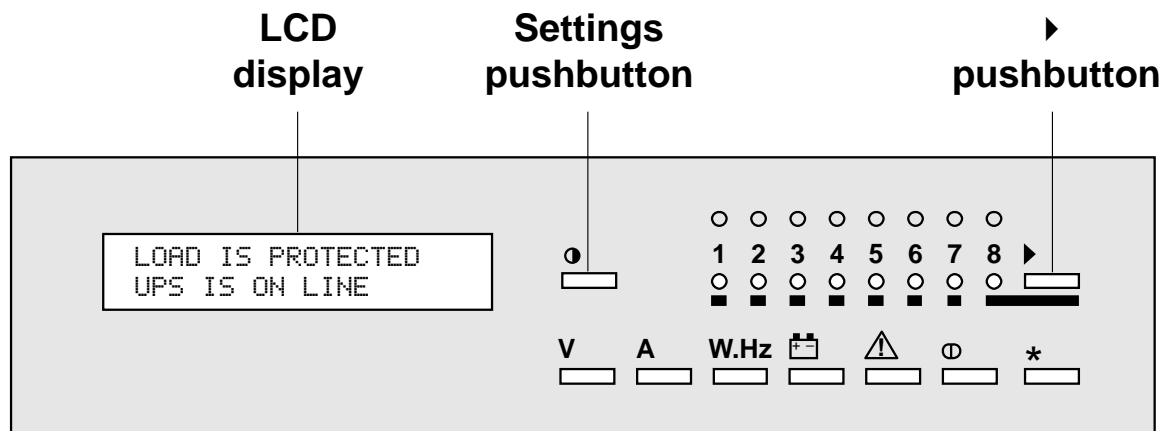

**Settings pushbutton**

This pushbutton is used to select the display language and adjust the LCD screen contrast for optimal viewing.



**Pushbutton**

This pushbutton primarily allows the selection of which UPS module or SSC the display communicates with; it may also serve to indicate selection, negative response, and other functions, depending on the displayed message.



**Pushbutton**

This pushbutton provides access to voltage measurements, including:

- Main AC input (mains 1) phase-to-phase voltage
- Bypass AC input (mains 2) phase-to-neutral and phase-to-phase voltage
- Inverter output phase-to-neutral and phase-to-phase voltage
- Load phase-to-neutral and phase-to-phase voltage



**Pushbutton**

This pushbutton provides access to current measurements, including:

- Main AC input (mains 1) current
- Bypass AC input (mains 2) current

- Inverter current
- Load current
- Percent current drawn by the load relative to UPS module or SSC rating
- Crest factor per phase

### **W.Hz** Pushbutton

This pushbutton provides access to power and frequency measurements, including:

- Main AC input (mains 1) frequency
- Bypass AC input (mains 2) frequency
- Inverter frequency
- Power drawn by the load (in kW and kVA)
- Load power factor



### **Battery** pushbutton

This pushbutton provides access to battery measurements, including:

- Battery voltage
- Battery current
- Battery ambient temperature
- Battery time available
- Battery time remaining



### **Alarms** pushbutton

This pushbutton is used to display current alarms, or to display stored alarms.

If the alarm key is pressed repeatedly, the display will scroll through the stored alarm record, returning to the latest after the oldest is shown.

If a blinking character (!) appears in the display, the user may press the Alarm pushbutton again to scroll through additional useful information.



### **pushbutton**

This pushbutton is reserved for future use.



### **Pushbutton**

Depending on the displayed message, this pushbutton may serve to indicate confirmation, positive response, and other functions.

**Numbered lights**

The green light indicates the UPS module or SSC with which the display is currently communicating.

A red light indicates that the corresponding UPS module or SSC has an anomaly or is not communicating with the display.

Light #1 refers to the SSC; the UPS modules are numbered sequentially starting at #2.

**2.2.3 Hidden Panel**

The hidden panel is located directly below the front panel, behind the hinged cover, as shown in Figure 2-4. The hidden panel includes the following controls and indicators, as shown in Figure 2-7:

**Figure 2-7 Hidden Panel**

2-7

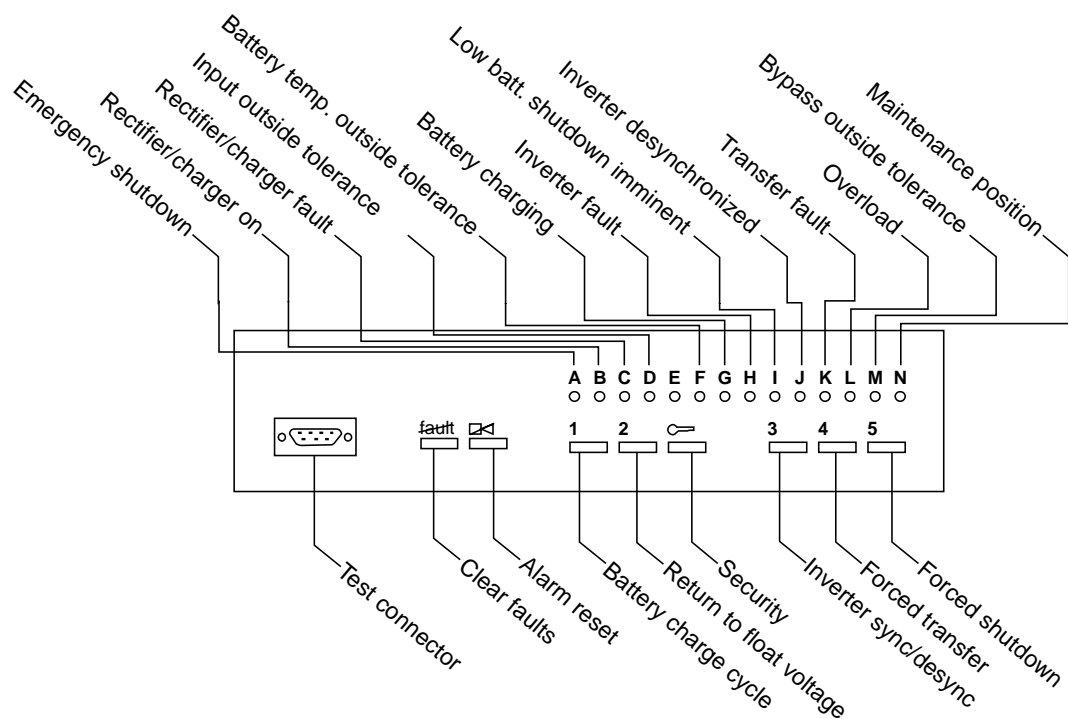

**Alphabetical lights**

Fourteen alphabetically labeled LEDs provide detailed information on UPS status as follows:

**A: Emergency shutdown**

This red LED indicates that the emergency power off (EPO) or remote emergency power off (REPO) has been activated (see Section 2.4.4.1, Emergency power off).

**B: Rectifier/charger on**

This green LED indicates that the rectifier/battery charger is on.

**C: Rectifier/charger fault**

This red LED indicates an alarm condition within the rectifier/battery charger. It indicates the presence of one of the following fault conditions:

- Input circuit breaker Q1 open
- Input power protection fuse blown
- Rectifier/battery charger over-temperature
- Battery charge overcurrent
- Battery overvoltage
- Rectifier/battery charger control board fault
- Power supply board fault

**D: Main AC input (mains 1) outside tolerance**

This orange LED indicates that the main AC input (mains 1) source is outside tolerance (voltage and/or frequency too high or too low).

**E: Reserved for future use.**

**F: Battery temperature outside tolerance**

This orange LED indicates that the ambient temperature of the battery is too high or too low.

**G: Battery charging**

This orange LED indicates that the battery is being recharged. This LED functions only when the connected battery is of the vented lead-acid type (sealed lead-acid batteries will not activate this signal).

**H: Inverter fault**

This red LED indicates an alarm condition in the inverter, which may be one or more of the following conditions:

- Inverter shutdown due to output voltage out of tolerance
- Inverter output protection fuse blown
- Inverter leg fault
- Inverter output transformer over-temperature
- Inverter leg over-temperature
- Current sharing fault
- Internal clock fault
- Inverter control board fault
- Power supply board fault

**I: Battery discharged**

This orange LED indicates that the battery has reached the end of its autonomy, shutting down the inverter.

### **J: Inverter desynchronized**

This orange LED indicates that the inverter output frequency is not synchronized with the bypass AC input (mains 2).

### **K: Transfer fault**

This red LED indicates a transfer fault, which may be one or more of the following conditions:

- Inverter output contactor K3N fault
- Current sharing relay fault
- Static switch power supply fault
- Transfer control board fault
- Power supply board fault

### **L: Overload**

This orange LED indicates an alarm condition resulting from one or more of the following conditions:

- UPS module inverter current above rating
- UPS module output current above rating
- SSC output current above rating
- UPS module and/or SSC shutdown due to excessive load current

### **M: Bypass AC input (mains 2) outside tolerance**

This orange LED indicates that the bypass AC input (mains 2) voltage and/or frequency are too high or too low.

### **N: Maintenance position**

This orange LED indicates that circuit breakers QF1, Q4S, Q5N, or Q3BP are set to the maintenance position. The UPS module or SSC is not available for load protection.

### **Test connector (Figure 2-8)**

This 9-pin connector is reserved for service. It is used to connect the cabinet to a computer, allowing system calibration, personalization, and computer-aided diagnostics.

### **Pushbuttons**

Following are brief descriptions of the function of the hidden panel pushbuttons, shown in Figure 2-8.

#### **Clear fault log**

Pressing this pushbutton clears the alarms stored in memory, allowing the unit to restart. Memorized alarms cannot be cleared until the condition causing the alarm has been corrected.

#### **Audible alarm reset**

Pressing this pushbutton stops the audible alarm. Should a new fault condition at a higher alarm level occur, the alarm will sound again.

Figure Hidden Panel Pushbuttons

2-8

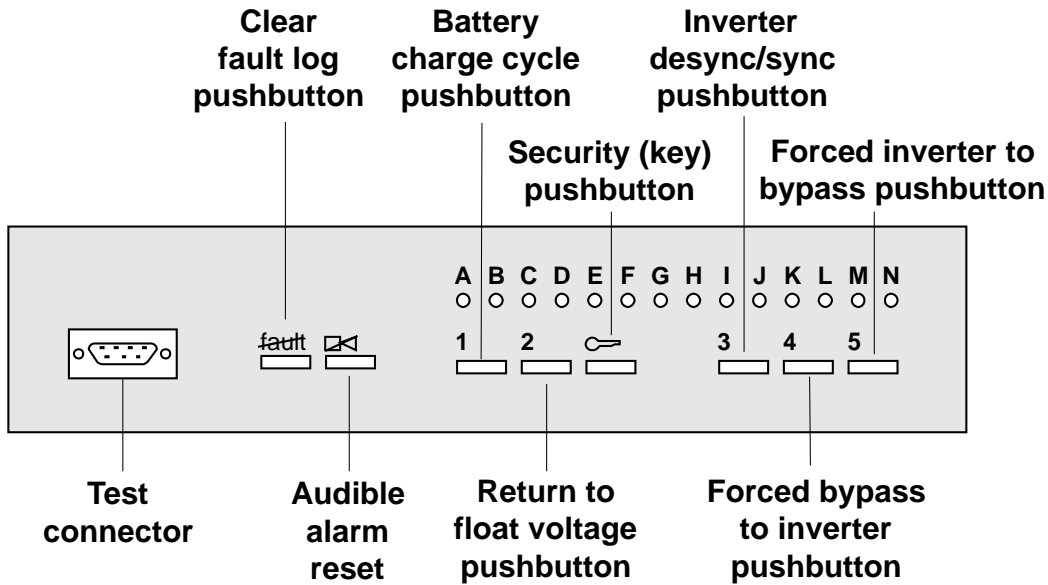

**Battery charge cycle (pushbutton #1) (applies to UPS module only)**

Pressing this pushbutton begins a battery charging cycle. After the cycle is complete, the rectifier/battery charger returns to float charge levels on the battery. The battery charge cycle is not applicable to sealed lead-acid battery installations.

**Return to float voltage (pushbutton #2) (applies to UPS module only)**

This pushbutton can be used during a battery charge cycle to force the rectifier/battery charger back to the float voltage level.

**Security pushbutton (key)**

This pushbutton must be pressed simultaneously with any of the following three pushbuttons. This helps guard against inadvertent transfer of the load with interruption.

**Inverter desync/sync (pushbutton #3) (applies to SSC only)**

Pressing and holding the "security key" while pressing this pushbutton forces the inverter output to desynchronize or synchronize to the bypass AC input (mains 2) source.



**CAUTION**

Using the forced transfer functions will cause the load to experience an interruption for a minimum of 0.8 seconds. Be certain the the load can tolerate this interruption; see Section 2.4.6, Forced Transfers.

**Forced bypass to inverter (pushbutton #4) (applies to SSC only)**

Pressing and holding the “security key” while pressing this pushbutton forces the transfer of the load to the inverter output when the bypass is out of tolerance. Enough UPS modules must have been started; press the “inverter on” pushbutton on their front panels if necessary. **The load will experience a 0.8 second interruption.** Refer to Section 2.4.2, Start-up, and Section 2.4.6, Forced Transfers.

**Forced inverter to bypass (pushbutton #5) (applies to UPS module only)**

Pressing and holding the “security key” while pressing this pushbutton stops the inverter and disconnects the module from the load, even if the bypass is out of tolerance; **if all UPS modules are stopped, the load will be transferred to bypass with a 0.8 second interruption.** Refer to Section 2.4.6, Forced Transfers.



**CAUTION**

**Using the forced transfer functions will cause the load to experience an interruption for a minimum of 0.8 seconds. Be certain the the load can tolerate this interruption; see Section 2.4.6, Forced Transfers.**

**2.2.4 Circuit Breakers, Contactors and Switches**

EPS 6000 circuit breakers and switches (except the battery disconnect circuit breaker QF1) are located behind the doors of the UPS cabinet, or through the door in the optional MBC. Following is a brief description of the available circuit breakers, contactors and switches, and their function. The single-line diagram in Figure 2-9

shows the location of each circuit breaker, contactor and switch within the electrical path, and Figure 2-10 through Figure 2-17 show the location of each switch, contactor and circuit breaker within the enclosures.

**Upstream of the SSC:**

**Q4S** Customer-supplied upstream circuit breaker, used to isolate the SSC from the bypass AC input (mains 2) source and provide backfeed protection.

**In the SSC (and optional MBC):**

**Q2S** Wrap-around circuit breaker (automatic), used to supply the attached load via the bypass AC input (mains 2) source.

**Q3BP** (Optional), system maintenance bypass circuit breaker, used to supply the attached load via the maintenance bypass source while the SSC is being serviced.

**Q5N** (Optional), system isolation circuit breaker, used to isolate the shared system from the

# EPS 6000 UPS Shared Systems

attached load.

Figure **Single-Line Diagram,**  
2-9 **Typical EPS 6000 UPS Shared Installation**

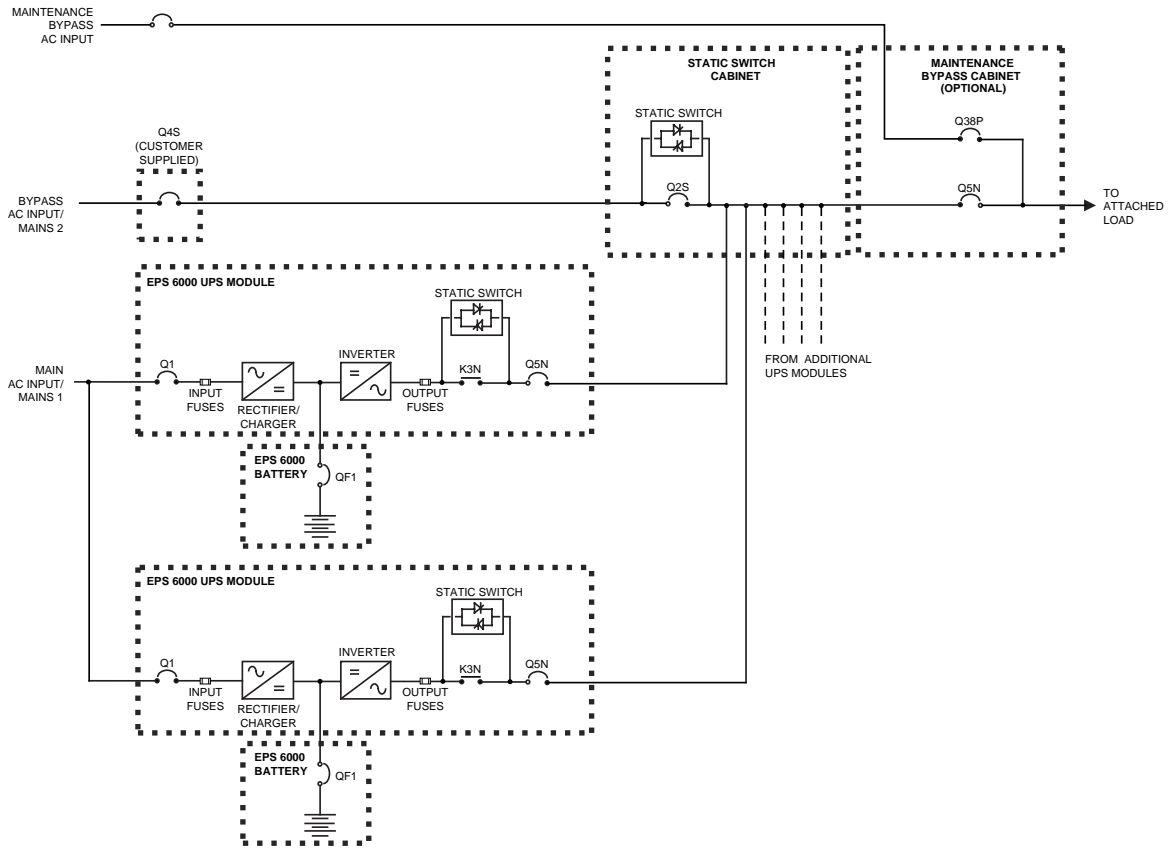
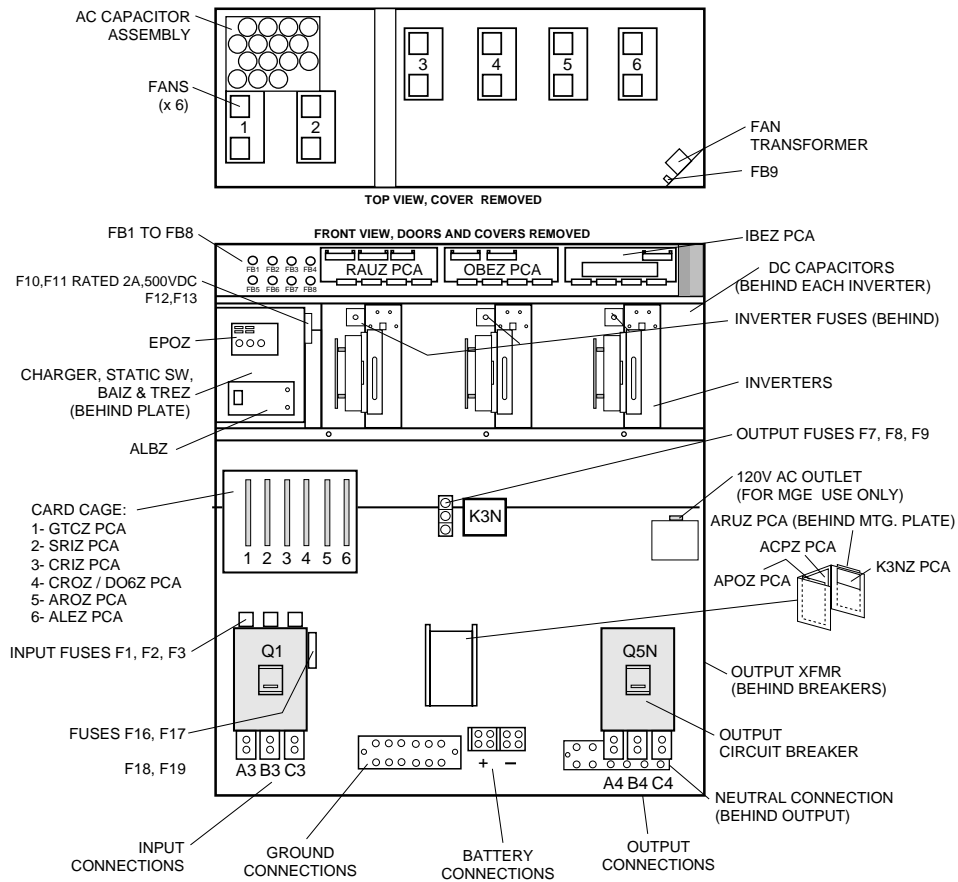



Figure EPS 6000 Major Internal Components,  
2-10 Shared 150 - 225 kVA UPS Module



# EPS 6000 UPS Shared Systems

Figure EPS 6000 Major Internal Components,  
2-11 Shared 300 / 375 kVA UPS Module

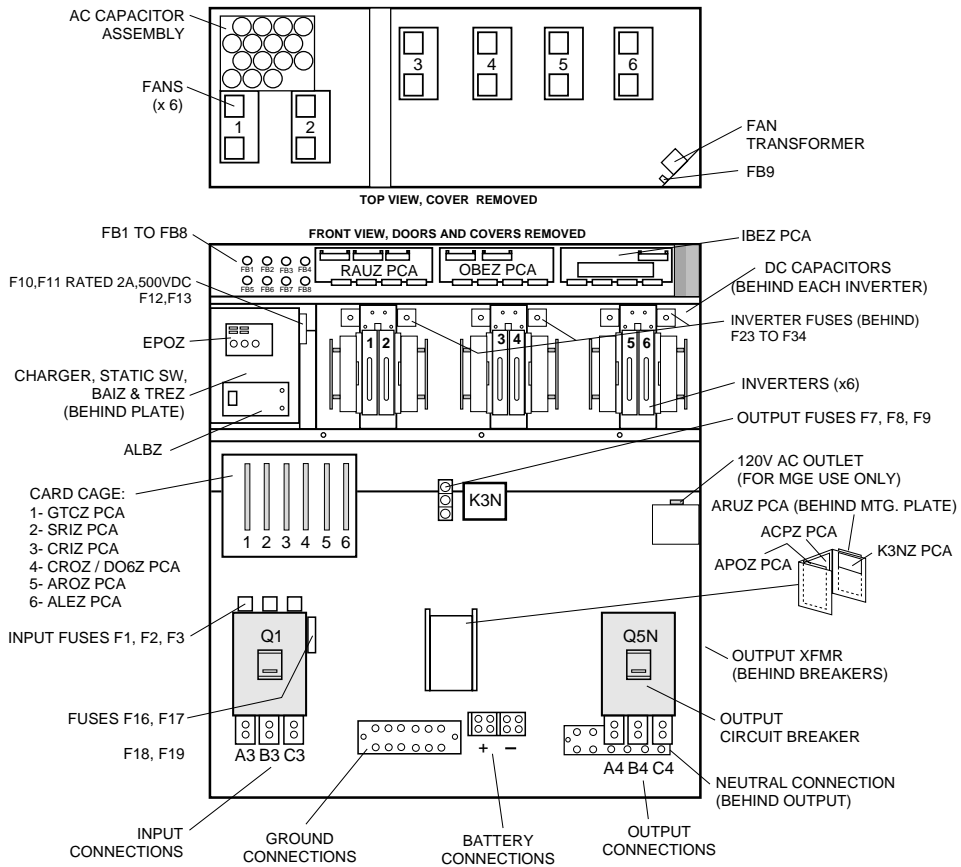
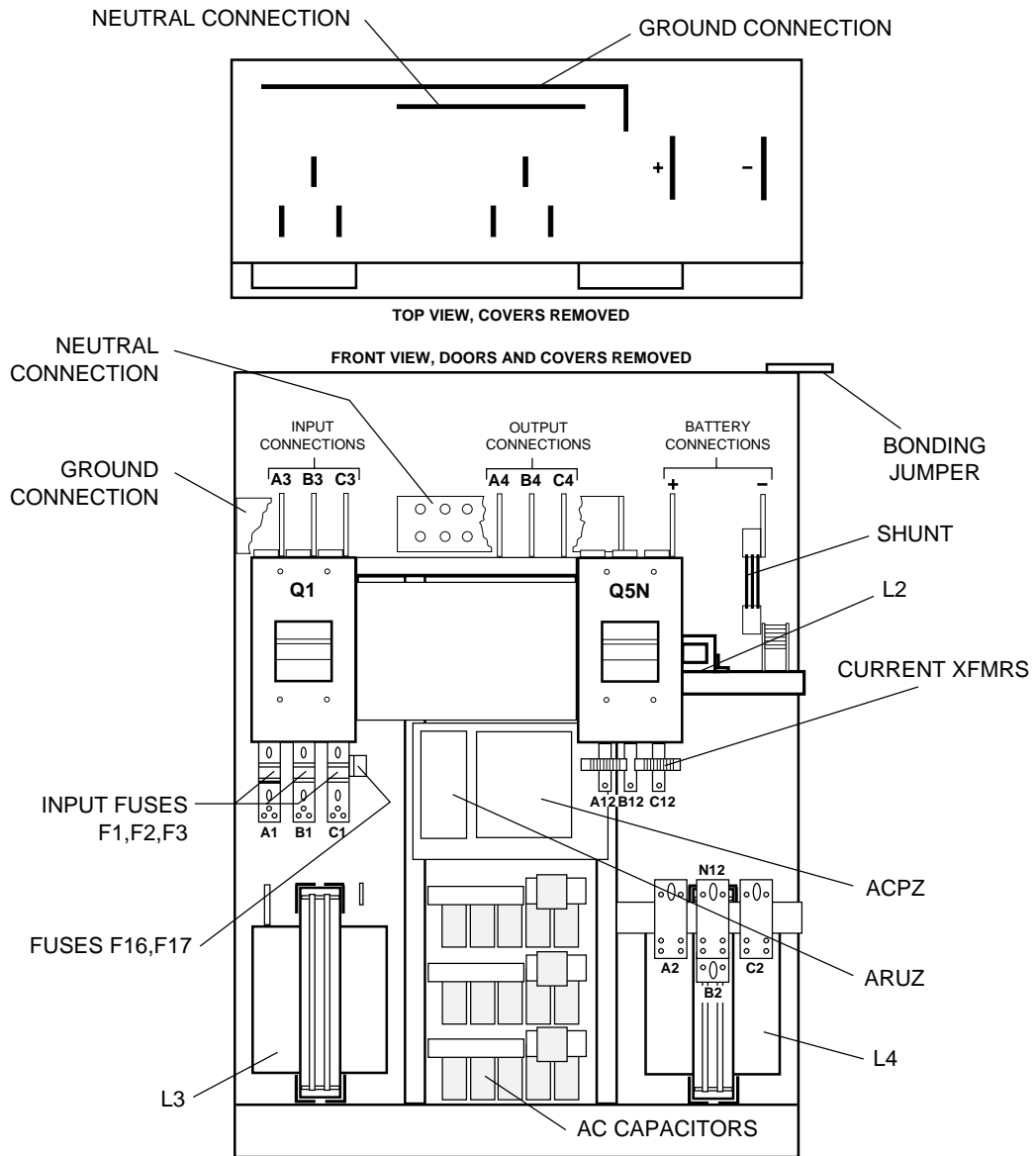

Figure EPS 6000 Major Internal Components,  
2-12 Shared 500 kVA UPS Module I/O Cabinet



# EPS 6000 UPS Shared Systems

Figure EPS 6000 Major Internal Components,  
2-13 Shared 500 kVA UPS Module UPS Cabinet

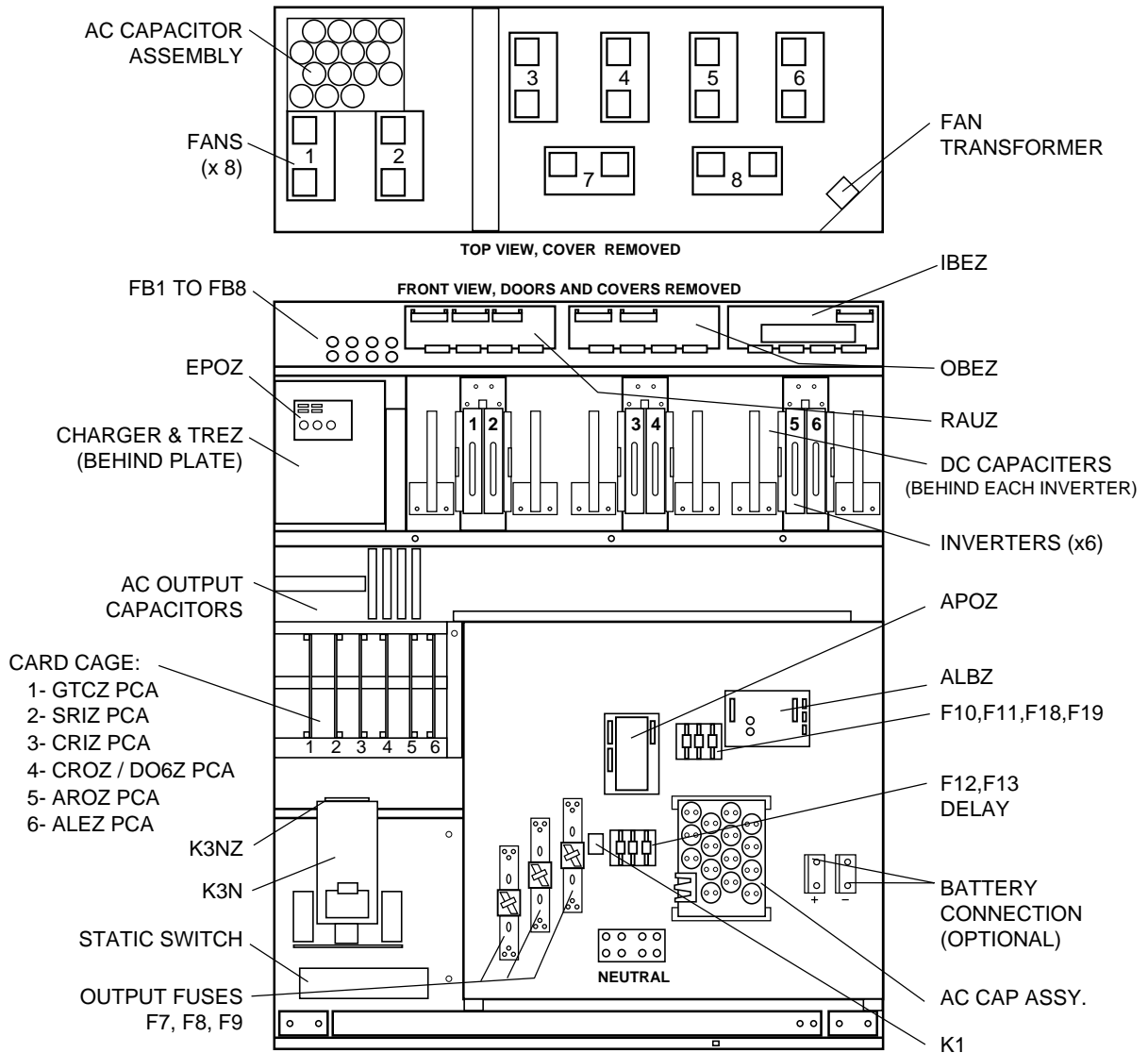
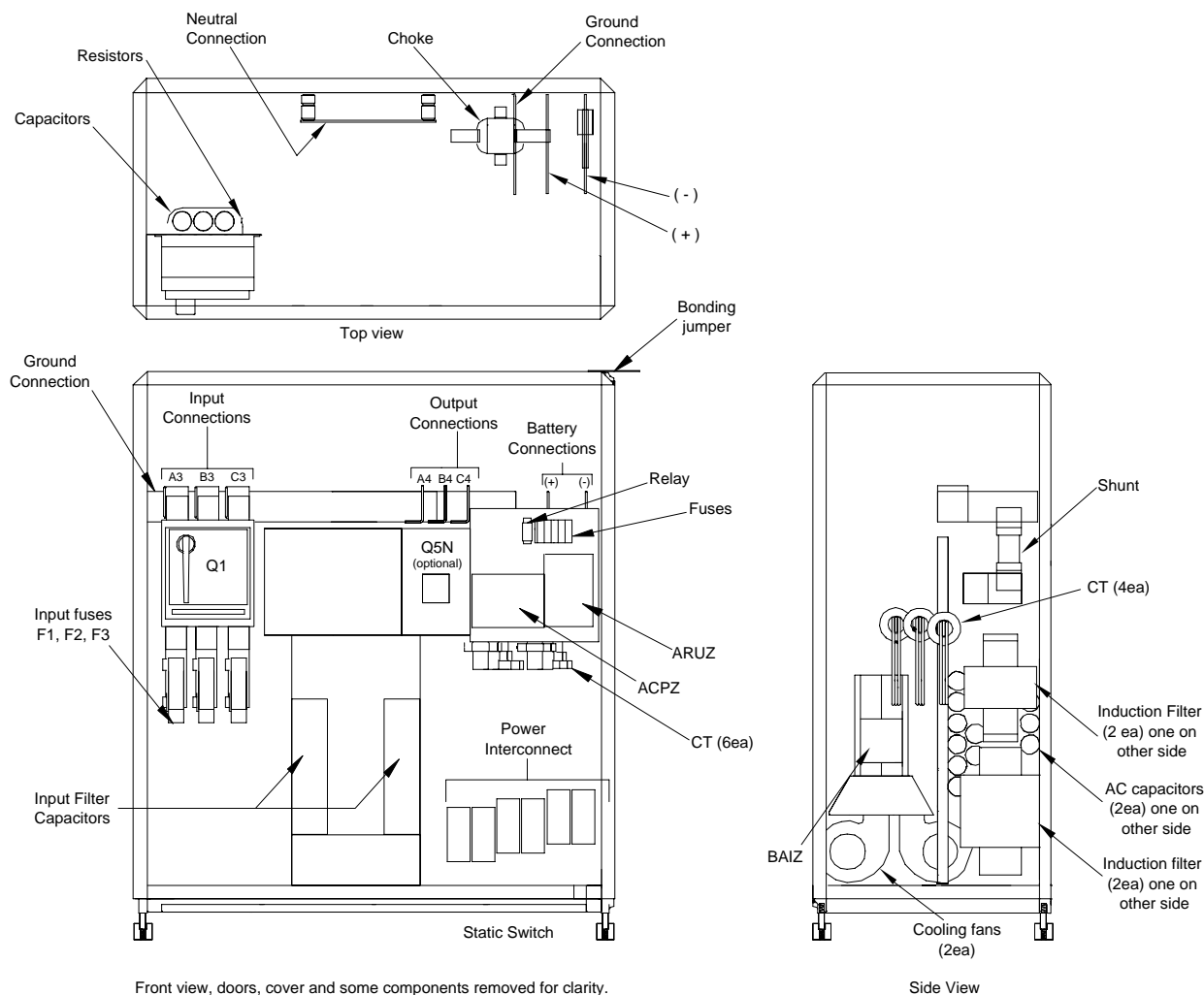

Figure EPS 6000 Major Internal Components,  
2-14 Shared 750 kVA UPS Module UPS Cabinet 1



# EPS 6000 UPS Shared Systems

Figure EPS 6000 Major Internal Components,  
2-15 Shared 750 kVA UPS Module UPS Cabinet 2

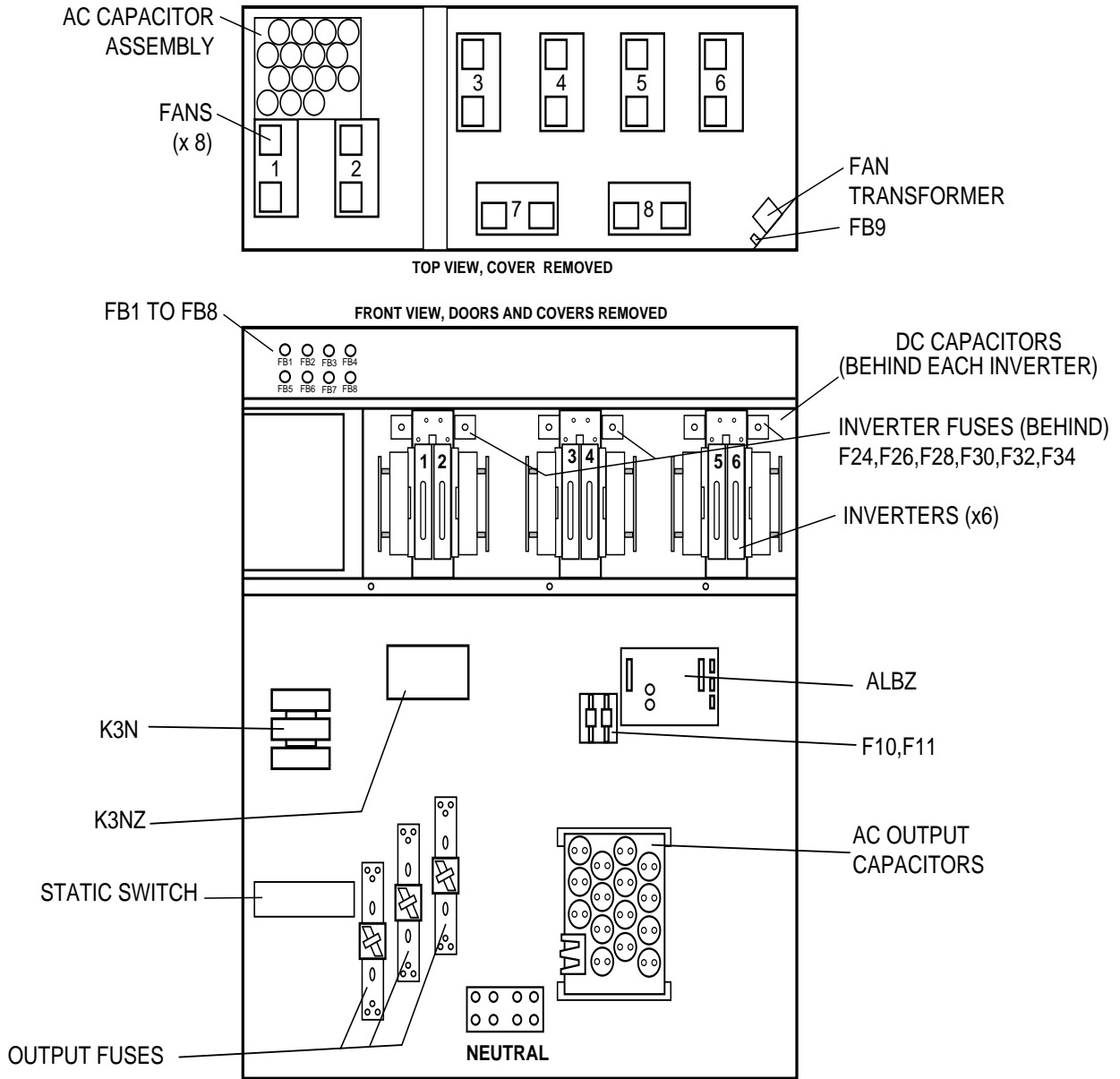
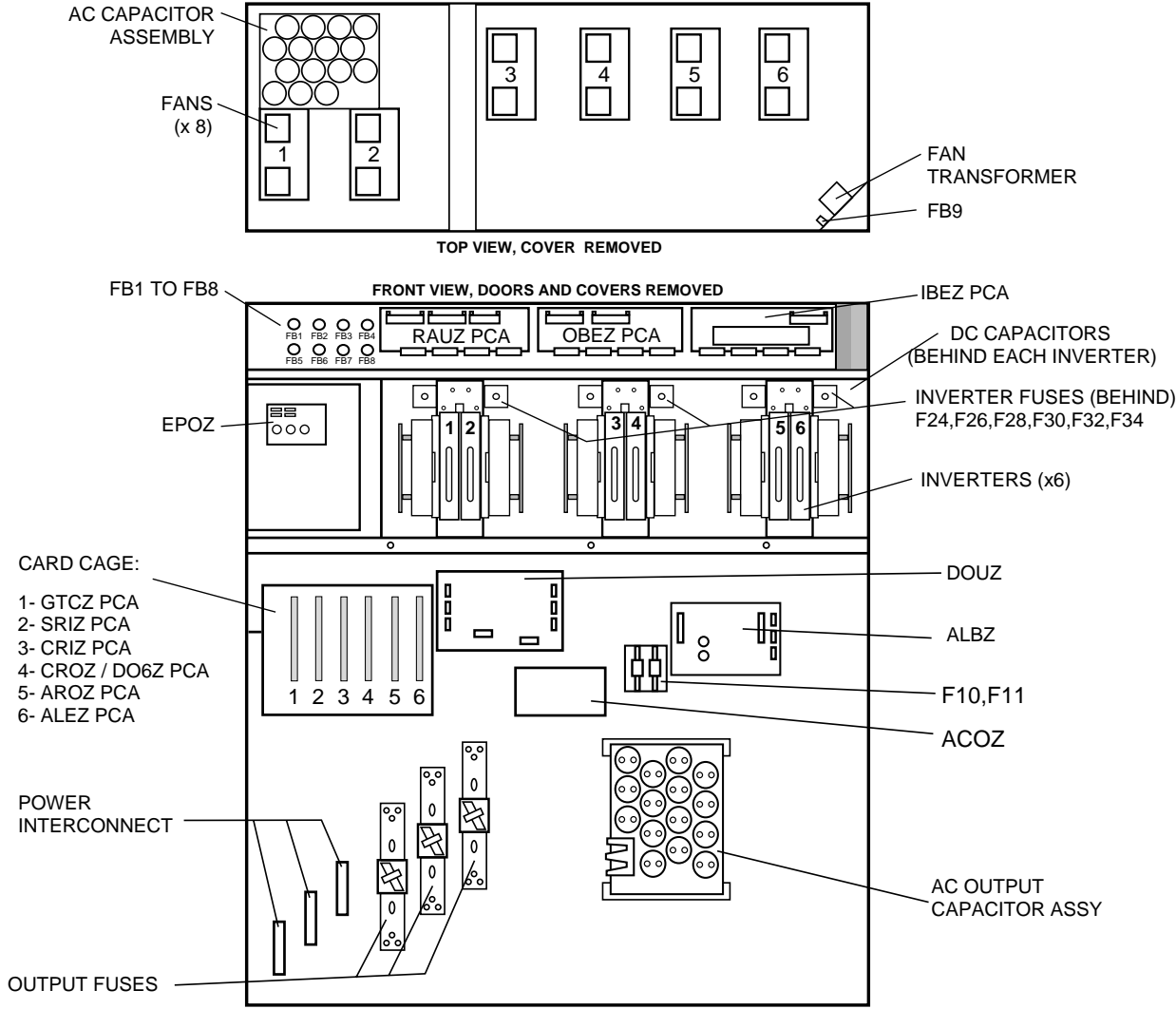
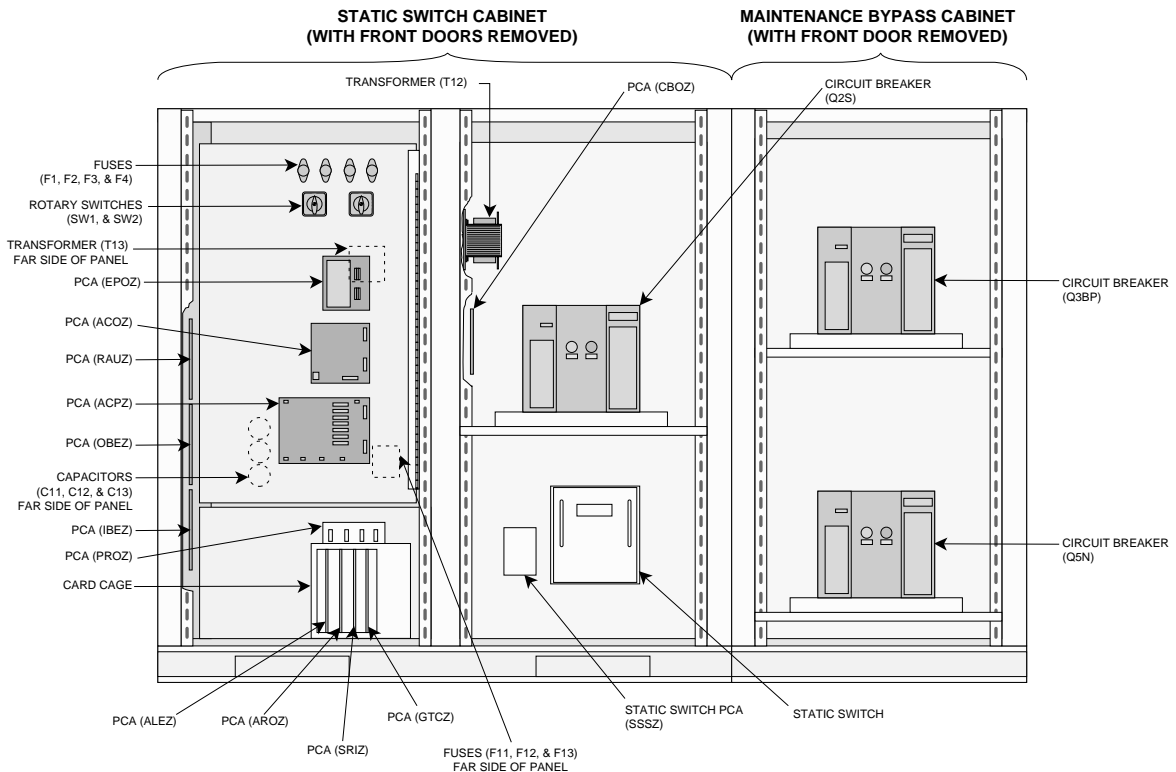

Figure EPS 6000 Major Internal Components,  
2-16 Shared 750 kVA UPS Module UPS Cabinet 3



# EPS 6000 UPS Shared Systems

Figure EPS 6000 Major Internal Components,  
2-17 Static Switch Cabinet (SSC)



**In the UPS modules:**

- Q1** Input isolation circuit breaker, used to isolate the UPS module from the main AC input (mains 1) source and provide input current protection.
- Q5N** UPS isolation circuit breaker, used to isolate the UPS module from the attached load.
- K3N** Inverter output contactor (automatic), used to isolate the inverter when it is off.

**In the circuit of the battery of each UPS module:**

- QF1** Battery disconnect circuit breaker, used to disconnect the battery from the UPS. QF1 provides isolation and protection between the UPS module and its battery system.



## 2.3 Using the Alphanumeric Display

This section describes operation and use of the alphanumeric display in detail.

The alphanumeric display interacts with the user via the top half of the hidden panel (Figure 2-4). Figure 2-18 shows the general organization of the alphanumeric display.

During normal operation, when there are no alarm conditions present and the load is supplied by the UPS inverter output, the display will present the general status message:

```
LOAD IS PROTECTED
UPS IS ON LINE
```

When there are alarm conditions, the display will present a general alarm message, and the user can use the "alarm" pushbutton (!) to determine the exact cause of the alarm condition (see Section 2.3.2, Alarms).

The following sections present detailed operating instructions for the alphanumeric display.

Figure 2-18 Alphanumeric Display

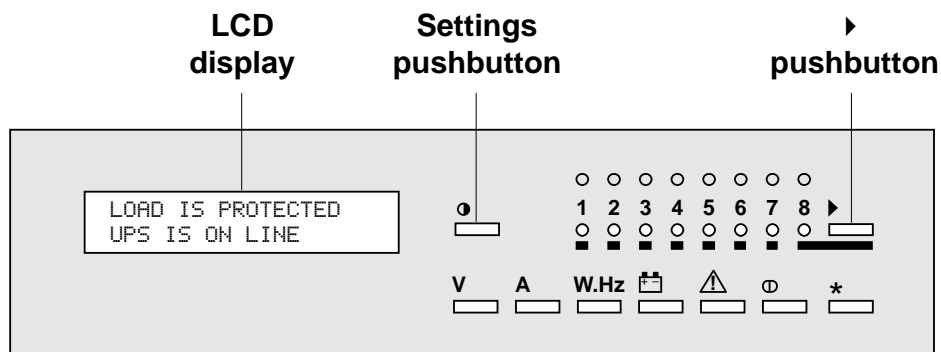
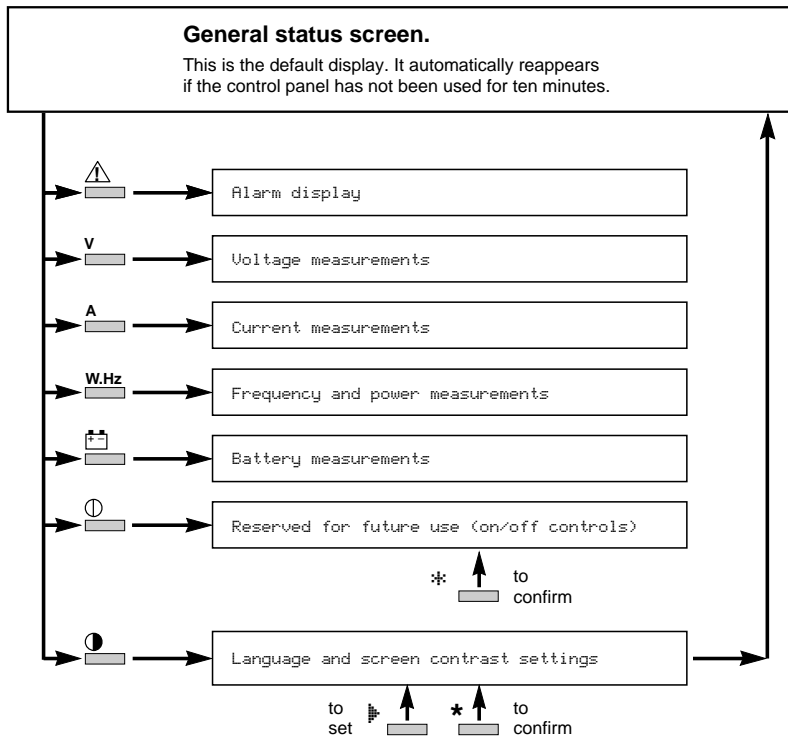

Figure 2-19 **General Display Configuration**



## 2.3.1 Settings

The settings selection screens allow the user to configure the display language and set the contrast of the LCD display.

To access the settings selection screen, press the settings pushbutton, and follow the steps as indicated in Figure 2-20.

Figure 2-20 **Display Settings Display**

2-20

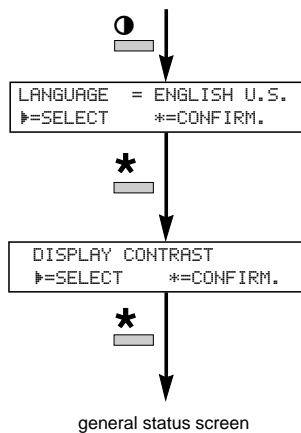

Press the settings pushbutton to access the language selection menu.

Select the display language: French, English (U.K.), Spanish, Dutch, Italian, Swedish, Portugese, or English U.S.

Press the \* pushbutton to confirm the language selection and access the contrast selection menu.

Set the display contrast by pressing the ▶ pushbutton until the desired contrast is reached.

Press the \* pushbutton to confirm the contrast selection and return to the general status screen.

**IMPORTANT**

Select **ENGLISH U.S.** as the display language to match the displays as presented in this manual.

### 2.3.2 Alarms

In the event of an alarm condition, the general status screen shows an alarm message. To determine the specific condition causing the alarm, press the alarm key on the front panel, as shown in Figure 2-21.

If there is a flashing exclamation mark (!) in the displayed message, there is additional information to be viewed. Follow the steps as indicated in Figure 2-21.

Most alarm messages are self-explanatory; see Section 2.5 for a listing of the most common alarm messages.

The most serious alarms are stored in the fault log, and may be viewed by following the steps shown in Figure 2-21. To reset the alarms, press the "clear fault log" pushbutton (see Section 2.2.3).

Figure 2-21 **Displaying Alarm Messages**

2-21

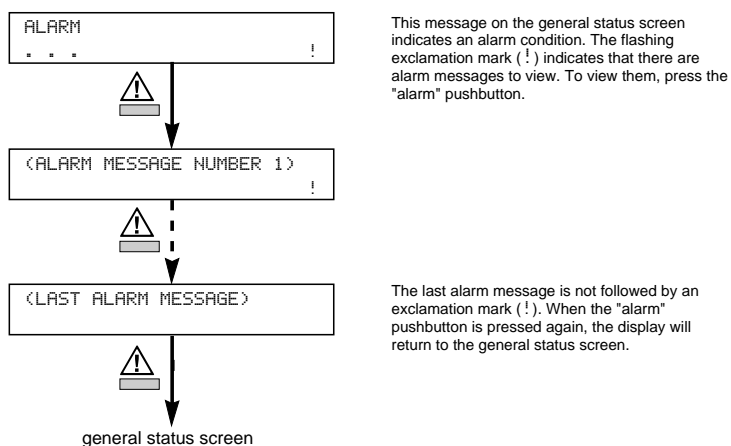

## 2.3.3 Measurements

The LCD can display comprehensive information about UPS performance through its monitoring functions.

### 2.3.3.1 Voltage Measurements

To display voltage measurements, press the “V” key on the keyboard, as shown in Figure 2-22.

Figure Voltage Measurements

2-22

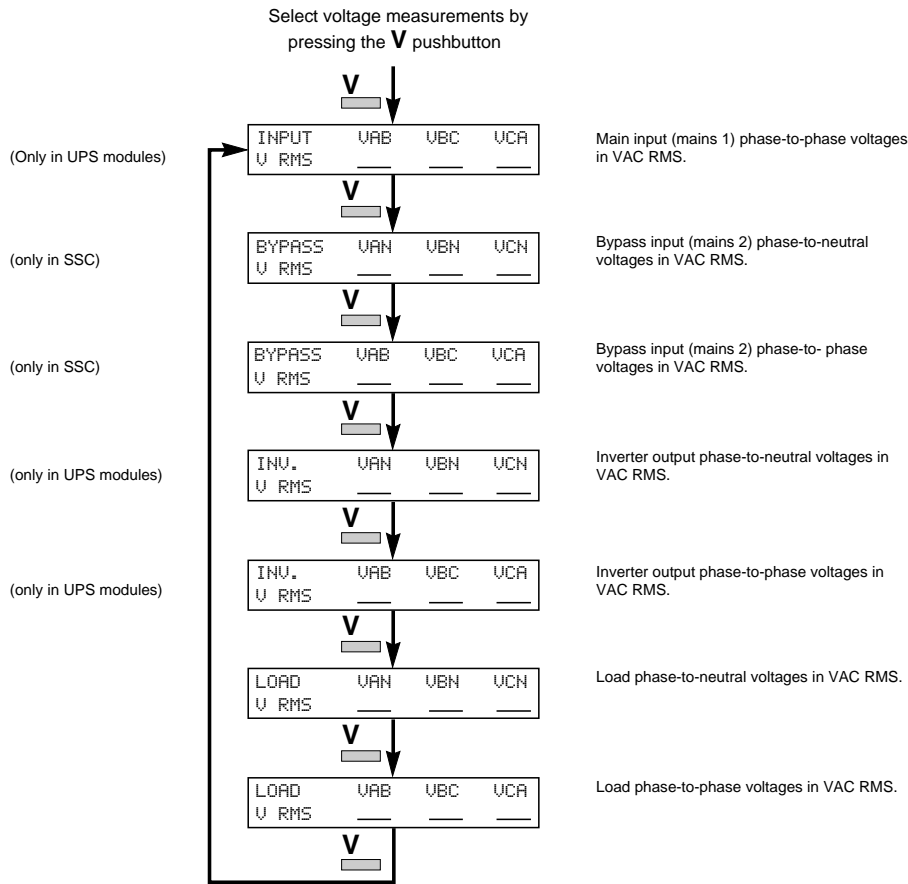

To display current measurements, press the "A" key on the keyboard, as shown in Figure 2-23.

Figure Current Measurements

2-23

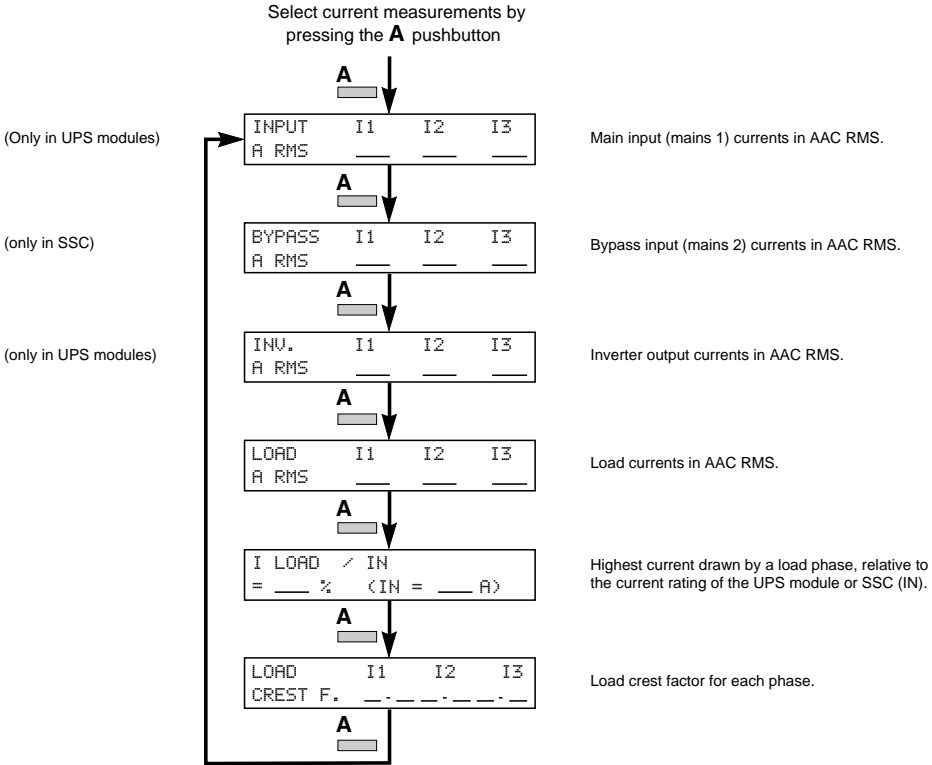

## 2.3.3.3 Power and Frequency Measurements

To display power or frequency measurements, press the “W.Hz” key on the keyboard, as shown in Figure 2-24.

Figure Power and Frequency Measurements

2-24

Select power and frequency measurements by pressing the **WHz** pushbutton.

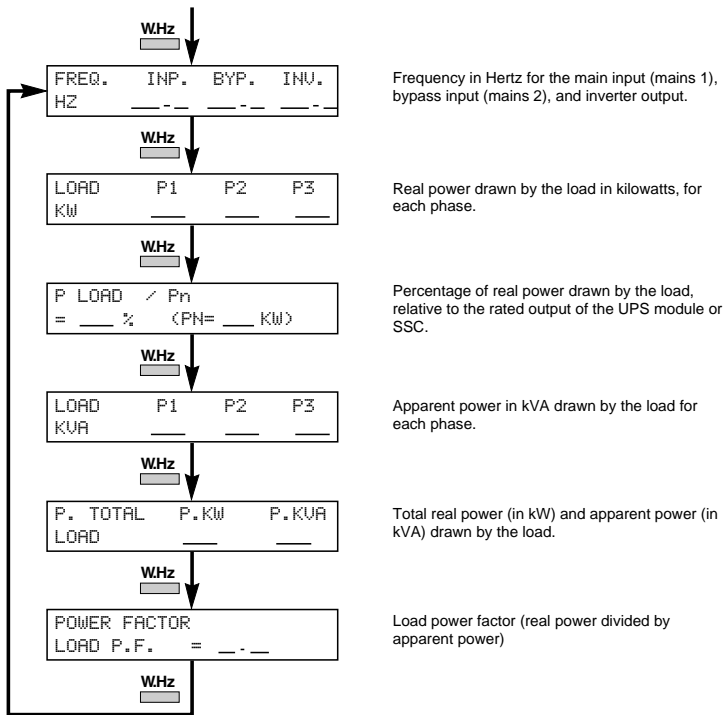

To display battery voltage, current, ambient temperature, and time available or remaining, press the battery key on the keyboard, as shown in Figure 2-25.

Figure 2-25 Battery Measurements

2-25

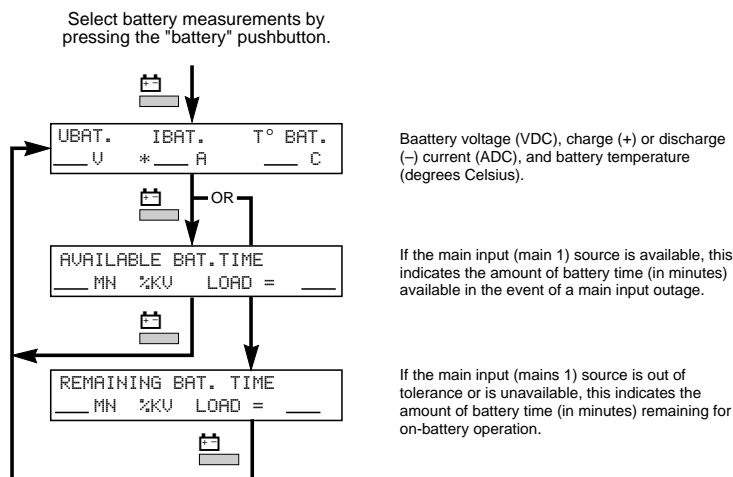

## 2.4 Normal Operating Procedures

This section presents normal operating procedures for the EPS 6000 UPS.

It is best to contact MGE Customer Support Services for start-up and maintenance of the EPS 6000 UPS. Do not allow unqualified personnel to operate the EPS 6000.

### 2.4.1 Checks Before Start-up

Before starting the EPS 6000 UPS, make certain that these conditions exist (as applicable to your installation):

- All power and control wires have been properly connected and securely tightened.
- The upstream and downstream protective devices are not tripped, and have been sized properly for the UPS and load requirements.
- The voltage at each main AC input circuit breaker Q1 and at the bypass input circuit breaker Q4S is the same as indicated on the UPS nameplate, located inside the right door of the EPS 6000 UPS module.
- The air filters located inside each EPS 6000 UPS module front door are properly installed and free of dust, dirt, and debris. Make certain that no objects block the air intake at the front bottom of the enclosures, and that the air exhaust at the top rear of the enclosures is free of obstructions.

In the individual UPS modules:

- Input (isolation) circuit breaker Q1 is in the OFF (open) position.
- Battery disconnect circuit breaker QF1 is in the OFF (open) position.
- Output isolation circuit breaker Q5N is in the OFF (open) position.

In the SSC:

- System maintenance bypass circuit breaker Q3BP is in the OFF (open) position (if present).
- System output isolation circuit breaker Q5N is in the OFF (open) position (if present).
- Input power supply switches SW1 and SW2 are in the ON (closed) position.
- The upstream bypass AC input (mains 2) circuit breaker (Q4S, customer-supplied) is in the OFF (open) position.
- If present, the upstream maintenance bypass circuit breaker (customer-supplied) is in the OFF (open) position.

### 2.4.2 Start-up

The following start-up procedure should be performed during the initial start-up following installation of the system, and this sequence should be followed any time that the EPS 6000 UPS system is being restarted from an off condition (i.e., after the UPS has been powered down by removing the upstream AC input power and opening all the circuit breakers of the UPS system).

- a. Apply power to Q4S by closing the upstream circuit breaker supplying Q4S, and the upstream circuit breaker supplying the optional maintenance bypass input (if present).
- b. Apply power to the UPS modules by closing the upstream circuit breaker supplying the main AC input (mains 1).
- c. Start the SSC:
  1. Close the optional system maintenance bypass circuit breaker Q3BP (if present, in the maintenance bypass cabinet). Power is now available at the SSC output (the load is energized) via the maintenance bypass source.
  2. Close the upstream circuit breaker Q4S that supplies the bypass input to the SSC. The SSC will come on-line; after about ten (10) seconds, the wrap-around circuit breaker Q2S will automatically close.
  3. Close the optional system isolation circuit breaker Q5N (if present, in the maintenance bypass cabinet).
  4. Open the optional system maintenance bypass circuit breaker Q3BP (if present). The SSC is now on-line and the load is supplied via the bypass source.

Note that if your SSC configuration does not include the maintenance bypass option, start-up requires only closing Q4S to supply the bypass source to the SSC. All other functions are fully automatic.



## d. Start the UPS modules:

1. For each module, close the input isolation circuit breaker Q1. Verify that the following conditions exist:
  - The red "load not protected" LED is on
  - The rectifier/battery charger automatically starts

If either condition is not present, there is a fault. Open Q1 and contact MGE Customer Support Services.

2. For each module, close the UPS isolation circuit breaker Q5N. The fans in the UPS module will start.
3. For each module, close the battery disconnect circuit breaker QF1. The batteries are now connected to the rectifier/battery charger, and have begun charging.

**IMPORTANT**

**Because it is standard for the UPS module to be programmed for automatic restart, the inverter will automatically start after the battery disconnect circuit breaker QF1 has been closed.**

4. If the modules are not programmed for automatic restart, for each module, press the "inverter on" pushbutton. The green "load protected" LED will flash for about 3 seconds, indicating that the inverter is starting.
5. As soon as a sufficient number of UPS modules have been started, the SSC will automatically transfer the load to the UPS module output. On each module, the green "load protected" LED will turn on and remain on. On the SSC, the green "load protected" LED will turn on.

**NOTE**

**If the transfer conditions are not satisfied (bypass AC input sources is out of tolerance, or some other reason), a forced transfer is required. Refer to Section 2.4.6, Forced Transfers.**

6. As the remaining UPS modules are turned on (per step 4 above), their respective green "load protected" LEDs flash for three seconds, then remain on as the modules connect to the load. The load is equally shared between modules.

### 2.4.3 Checks After Start-up

After initial start-up of the system, normal operation should be tested. At the minimum, the following tests should be performed (as applicable to your installation):

- Emergency power off (EPO) test from each UPS module, and from the SSC.

- Remote emergency power off (REPO) test (if applicable).
- Inverter start and stop (for each module).
- Battery transfer test.
- Maintenance bypass procedure.

### 2.4.4 Shut-down

This section presents procedures for shutting down the system under normal, emergency, overload, and maintenance conditions.

#### 2.4.4.1 Emergency Shutdown Using EPO



#### CAUTION

**Pressing the EPO disconnects the attached load. The emergency power off (EPO) is to be used during emergency situations only, where a hazard to personnel or equipment exists, such as during a fire. DO NOT USE THE EPO TO TURN THE UPS ON OR OFF; follow the procedures listed in this section for turning the inverter on and off.**

During an emergency situation, such as a fire in the computer or electrical room, the UPS and all downstream devices can be instantly shut down by pressing the “emergency power off” (EPO) pushbutton on the front panel of the SSC, or by pressing the “remote emergency power off” (REPO) optional pushbutton located within the room.

The EPO or REPO pushbuttons should not be used for normal shutdown of the equipment; when activated, ground paths may be broken (depending on installation) and sensitive loads attached to the UPS may lose safety ground connection.

Each UPS module has an EPO feature that can be activated to shut down that module only (see Section 2.2.1).

To shut down an individual UPS module, press the “inverter off” pushbutton on the module front panel for 3 seconds. To restart, press the “inverter on” pushbutton. Note that the transfer will occur only if the inverter is synchronized to the bypass; otherwise, a forced transfer is needed (see Section 2.4.6).



### IMPORTANT

When one UPS module in a shared system is shut down, it may cause the remaining modules to enter an overload or current-limiting condition, if they are unable to fully support the attached load. The remaining modules may shut down after a certain time or immediately (depending on the load level), and the load may be transferred to the bypass AC input source.

## 2.4.5 Isolation for Maintenance

### 2.4.5.1 Isolation of an Individual UPS Module

To isolate an individual UPS module for maintenance (allowing the remaining UPS modules to maintain the attached load), follow this procedure (starting with all UPS modules operating normally, supplying the attached load):

1. Stop the inverter by pressing the “inverter off” pushbutton on the UPS module front panel for 3 seconds. The audible alarm will sound; silence the alarm by pressing the audible alarm reset pushbutton on the hidden panel (see Section 2.2.3). If the transfer conditions are not satisfied (bypass out of tolerance or other reason), a forced transfer is required; refer to Section 2.4.6, Forced Transfers.



### IMPORTANT

When one UPS module in a shared system is shut down, it may cause the remaining modules to enter an overload or current-limiting condition, if they are unable to fully support the attached load. The remaining modules may shut down after a certain time or immediately (depending on the load level), and the load may be transferred to the bypass AC input source.

2. Open the UPS isolation circuit breaker Q5N.
3. Open the battery disconnect circuit breaker(s) QF1.
4. Open the input isolation circuit breaker Q1.

The UPS module is now isolated for maintenance. For complete protection, the upstream circuit breaker supplying the UPS module should be opened, locked, and tagged while the UPS is being serviced.

To restart the UPS module after maintenance:

1. Close the input isolation circuit breaker Q1.
2. Close the isolation circuit breaker Q5N. The UPS module fans will start.
3. Wait for the green LED "B" on the hidden panel to turn on (indicating that the rectifier/battery charger has started), then close the battery disconnect circuit breaker QF1. If there is more than one battery cabinet in your configuration, close all the battery disconnect circuit breakers.



### IMPORTANT

Because it is standard for the UPS module to be programmed for automatic restart, the inverter will automatically start after the battery disconnect circuit breaker QF1 has been closed.

4. If the module is not programmed for automatic restart, start the inverter by pressing the "inverter on" pushbutton on the UPS front panel. In a few moments, the inverter will start and the UPS module will resume normal operation. If the transfer conditions are not satisfied (bypass out of tolerance or other reason), a forced transfer will be required. Refer to Section 2.4.2, Start-up, and Section 2.4.6, Forced Transfers.

## 2.4.5.2 Isolation of Static Switch Cabinet (SSC)

To isolate the SSC for maintenance, or to transfer the load to maintenance bypass input source (if present), follow the procedure that applies to your configuration.

### 2.4.5.2.1 Without Maintenance Bypass

This procedure assumes that the UPS system is operating normally, with the attached load supplied via the UPS modules.

1. Isolate all the UPS modules by following the procedure in Section 2.4.5.1.
2. Open the upstream bypass circuit breaker Q4S.



#### CAUTION

**Opening Q4S with the UPS modules off in a UPS system with no maintenance bypass will disconnect the attached load.**

The whole UPS system is now isolated for maintenance. For complete protection, Q4S or the upstream circuit breaker supplying Q4S should be locked open and tagged while the UPS system is being serviced.

To restart the UPS system after maintenance:

1. Close the upstream bypass circuit breaker Q4S. After about 10 seconds, the wrap-around circuit breaker Q2S will close and supply the attached load via the bypass source.
2. Restart the UPS modules by following the procedure in Section 2.4.5.1.

### 2.4.5.2.2 With Maintenance Bypass

This procedure assumes that the UPS system is operating normally, with the attached load supplied via the UPS modules:

1. Isolate all the UPS modules by following the procedure in Section 2.4.5.1.
2. Close the system maintenance bypass circuit breaker Q3BP.
3. Open the system isolation circuit breaker Q5N. The SSC is now isolated from the load, which is supplied by the maintenance bypass AC input source.
4. Open the upstream bypass circuit breaker Q4S.

## EPS 6000 UPS Shared Systems

---

The whole UPS system is now isolated for maintenance. For complete protection, Q4S or the upstream circuit breaker supplying Q4S should be locked open and tagged while the UPS is being serviced.

To restart the UPS system after maintenance:

1. Close the upstream bypass circuit breaker Q4S. After about 10 seconds, the wrap-around circuit breaker Q2S will close.
2. Close the system isolation circuit breaker Q5N.
3. Open the system maintenance bypass circuit breaker Q3BP. The SSC is now on line and the load is supplied via the bypass source.
4. Restart the UPS modules by following the procedure in Section 2.4.5.1.

### 2.4.6 Forced Transfers

This section describes the normal transfer conditions and the procedures to be followed when issuing forced transfers.



#### CAUTION

**Using the forced transfer functions will cause the load to experience an interruption for a minimum of 0.8 seconds. Be certain the the load can tolerate this interruption.**

#### 2.4.6.1 Uninterrupted Transfer Conditions

To transfer the load between the UPS module output and the bypass AC input (mains 2) source without interruption, the following conditions must be satisfied:

- UPS module output and bypass AC input phases must be in sync
- Bypass AC input voltage must be within 10% of nominal
- Bypass AC input frequency must be within a certain programmable tolerance of nominal

Provided that both the UPS module output and bypass AC input sources meet these conditions, uninterrupted transfers can take place. If these conditions are not met, transfers cannot take place without interruption. A forced transfer is required.

Forced transfers require a power interruption to the load of 0.8 seconds. Before issuing a forced transfer command, be certain that the attached load can tolerate the brief outage. The following paragraphs describe the forced transfer procedures.

### 2.4.6.2 Forced Transfer From Bypass AC Input Source to Inverter

This procedure assumes that the load is being supplied by the bypass AC input (mains 2) source via the SSC.

Start the UPS modules (refer to Section 2.4.2, steps d1 to d4). On the SSC hidden panel, press the "security" key (Figure 2-8, "key" pushbutton) and hold it while pressing the "forced bypass to inverter" key (pushbutton #4). If enough modules are on, the load will be disconnected for 0.8 seconds, then connected to the UPS modules.

### 2.4.6.3 Forced UPS Module Shut Down

On the UPS hidden panel, press the "security" key (Figure 2-8, "key" pushbutton) and hold it while pressing the "forced inverter to bypass" key (pushbutton #5). This stops the inverter and disconnects the UPS module. When all

modules are stopped, the load will be disconnected for 0.8 seconds, then connected to the bypass AC input source.



#### IMPORTANT

When one UPS module in a shared system is shut down, it may cause the remaining modules to enter an overload or current-limiting condition, if they are unable to fully support the attached load. The remaining modules may shut down after a certain time or immediately (depending on the load level), and the load may be transferred to the bypass AC input source.

## 2.5 LCD Messages

This section presents the most common alarm messages that appear on the LCD (the alphanumeric section of the "hidden" panel), and explains their meaning.

```
LOAD IS PROTECTED  
UPS IS ON LINE
```

This is the normal display message. There are no alarms or problems, and the load is being supplied by the UPS inverter.

# EPS 6000 UPS Shared Systems

---

## General alarms

```
LOW LEVEL ALARM
UPS OK    !
```

This message indicates that a problem requiring action has occurred. The load is still supplied by the inverter. The problem is listed in the secondary alarm message (see below), as indicated by the flashing exclamation mark (!). The alarm message may be viewed by pressing the “alarm” pushbutton (!).

```
UPS INPUT FAILURE
LOAD ON BATTERY !
```

This message indicates that the main AC input (mains 1) has failed or is outside of tolerance, and power to the inverter is being supplied from the UPS battery system. The load is still supplied via the inverter.

```
REMAINING BAT. TIME
__ MN  %KW LOAD = __
```

This message is automatically displayed every five seconds when the UPS is on battery. It alternates with the previous message. The message provides an estimate of the available remaining time on battery, based on the percentage of full rated load being supplied, the type of battery, the battery temperature, and the battery age.

```
UPS LOW BATTERY
SHUTDOWN IMMINENT !
```

This message indicates that the battery has reached the “low battery shutdown” warning level. The user must take steps to prepare the load for shutdown (load shedding, file saving and computer shutdown, etc.). This message replaces the previous two messages when the battery is nearly depleted. When this message appears, there are only a few minutes of battery back-up time remaining.

```
UPS ALARM
CALL SERVICE    !
```

This indicates that the battery disconnect circuit breaker QF1 has been opened or the inverter has stopped and that service is required. The problem is listed in the secondary alarm message (see below), as indicated by the flashing exclamation mark (!). The secondary alarm message may be viewed by pressing the “alarm” pushbutton (!).

## Secondary alarms

The presence of these alarms is indicated by a flashing exclamation mark (!) on the general alarm message. Press the “alarm” pushbutton to view these messages.

```
EMERGENCY SHUTDOWN
REPO ON    !
```

This message indicates that the UPS has been shut down because a remote emergency power off (REPO) pushbutton has been pressed.



LOAD ON  
BYPASS !

This message indicates that the load has been transferred to the bypass AC input (mains 2) source. The load is no longer protected.

BYPASS PROBLEM  
CHECK FREQUENCY !

This message indicates that the bypass AC input (mains 2) source is out of frequency tolerance. The inverter has switched to free-running mode. Transfer of the load from the inverter output to the bypass AC input source requires an interruption of power to the load.

BYPASS PROBLEM  
CHECK VOLTAGE !

This message indicates that the bypass AC input (mains 2) source is out of voltage tolerance. The inverter has switched to free-running mode. Transfer of the load from the inverter output to the bypass AC input source requires an interruption of power to the load.

INDEPENDENT INVERTER  
FREQ. COMMAND ON !

This message indicates that the inverter has been set to free-running mode. The inverter is not synchronized to the bypass AC input (mains 2) power source. Transfer of the load from the inverter output to the bypass AC input source requires an interruption of power to the load.

BYPASS TRANSFER  
LOCKOUT COMMAND ON !

This message indicates that the UPS has been set not to transfer from the inverter to the bypass AC input (mains 2) source. In the event of an inverter shutdown, the load will be disconnected.

BATTERY CABINET  
OVERTEMP. !

This message indicates that the ambient temperature of the battery is out of tolerance.

UPS INPUT PROBLEM  
CHECK FREQUENCY !

This message indicates that the main AC input (mains 1) frequency is out of tolerance. The rectifier/battery charger has shut down and the inverter is operating from its battery source.

UPS INPUT PROBLEM  
CHECK VOLTAGE !

This message indicates that the main AC input (mains 1) voltage is out of tolerance. The rectifier/battery charger has shut down and the inverter is operating from its battery source.

## EPS 6000 UPS Shared Systems

---

CHARGER SHUTDOWN  
COMMAND ON !

This message indicates that the rectifier/battery charger has been instructed to shut down, for example during progressive (stepped) transfer to a motor-generator set.

INPUT KVA LIMITED  
COMMAND ON !

This message indicates that the rectifier/battery charger has been instructed to limit the power drawn from the main AC input (mains 1) source. This condition occurs, for example, when the load is being supplied by an undersized motor-generator set; the UPS battery source is called upon to make up the difference.

BATTERY CURRENT  
LIMIT COMMAND ON !

This message indicates that the rectifier/battery charger has been instructed to limit the charge current to the battery. Normal charge current to the battery will be supplied when the command is released. This condition occurs, for example, when the load is being supplied by an undersized motor-generator set.

QF1 BATTERY BREAKER  
OPEN !

This message indicates that the battery circuit breaker QF1 has been opened or has tripped. The load is no longer protected, since battery power is unavailable.

LOW BATTERY  
. . . !

This message indicates that the UPS module has shut down, due to depletion of the battery's stored energy.

CHARGER OFF  
. . . !

This message indicates that the rectifier/battery charger has shut down.

CHARGER FAULT  
CALL SERVICE !

This message indicates that a fault has occurred in the rectifier/battery charger, and that service is required.

Q1 UPS INPUT CB  
OPEN !

This message indicates that the input isolation circuit breaker is open or has tripped. It must be closed for rectifier/battery charger start-up.

INVERTER OVERLOAD  
CHECK P.F. AND KW

This message indicates that the inverter is in an overload condition, usually due to excessive real power (kW) being drawn by the load. The flashing "KW" indicates that the operator should check the load real power. The inverter will keep supplying the load for a certain amount of time depending on the overload level.

INVERTER FAULT  
CALL SERVICE !

This message indicates that a fault has occurred in the inverter, and that service is required.

INVERTER SHUTDOWN  
OVERLOAD > I MAX!

This message indicates that an overload greater than 1.5 times the power rating of the inverter has occurred, and that the inverter has shut down.

INVERTER SHUTDOWN  
THERMAL OVERLOAD A

This message indicates that an overload below 1.5 times the power rating of the inverter has occurred and that the inverter has shut down. The flashing "A" indicates that the operator should check the load current.

I LOAD > IN  
CHECK LOAD A

This message indicates that the load power being drawn is greater than the full load rating. The flashing "A" indicates that the operator should check the load current. The UPS module or SSC will keep supplying the load for a certain amount of time depending on the overload level.

TRANSFER FAULT  
CALL SERVICE !

This message indicates that a fault has occurred that affects the transfer of the load between the inverter and the bypass source. Service is required.

PH OUT OF TOLERANCE !

This message indicates that there is an out of tolerance condition between the inverter and bypass AC input (mains 2) sources. Transfer of the load between the inverter and bypass AC input will result in an interruption of load power.

Q4S BYPASS SWITCH  
OPEN !

This message indicates that the upstream circuit breaker Q4S is open. Transfer of the load from the inverter to the bypass source is not possible.

## EPS 6000 UPS Shared Systems

---

Q5N UPS OUTPUT ISOL.  
SWITCH OPEN !

On a UPS module, this message indicates that the UPS module isolation circuit breaker Q5N is open, making it impossible for that module to supply the load. On the SSC, this message signals that the system isolation circuit breaker Q5N in the MBC is open, and the load is not supplied unless the maintenance bypass circuit breaker Q3BP is closed.

Q3BP MAINT. BYPASS  
SWITCH CLOSED !

This message indicates that the optional maintenance bypass circuit breaker Q3BP in the MBC is closed. The system is set to maintenance bypass, and the load is supplied by the maintenance bypass AC input source.

STATIC SWITCH O.L.  
EMERGENCY OFF !

This message indicates that the SSC's static switch and wrap-around circuit breaker Q2S have opened following an overload condition, disconnecting the load.

BATTERY CHARGING !

This message indicates that the battery is being recharged.

INDEPENDENT INVERTER  
FREQUENCY !

This message indicates that the inverter is operating in free-running mode, and is no longer synchronous with the bypass AC input source (mains 2). Inverter frequency is stable within 0.1 Hz, but transfer of the load to the bypass AC input source is not possible without an interruption of power to the load.

NUMBER OF MODULES  
READY INSUFFICIENT !

This message indicates that the load cannot be transferred from the bypass input source to the UPS modules because not enough UPS modules have been started up.

UPS  
TRANSFER LOCKOUT !

This message indicates that the load cannot be transferred from the inverter to the bypass AC input (mains 2) source without interruption because the conditions for transfer without interruption are not met (see Section 2.4.6.1), or because the inverter is operating in free-running mode or in current limit, or because the UPS has been commanded not to transfer without interruption, or because of an internal fault.

FAN FAILURE  
CALL SERVICE !

This message indicates that a fan has failed, and that service is required. Because the fans of the rectifier/battery charger and the inverter are redundant, the load is still supplied by the inverter.

AUXILIARY CABINET FAULT  
CALL SERVICE !

This message indicates that there is a fault in an auxiliary cabinet, and that service is required.

CALL SERVICE FOR  
BATTERY PM !

This message indicates that the battery may have reached its end of life (based on the rated lifetime and the conditions of use).

MODULE NUMBER X  
UNAVAILABLE

This message indicates that the core controller of the selected module (UPS module or SSC, see Section 2.2.2) is not sending data to the alphanumeric display. The status of the module is still correctly indicated by the LEDs of the visible panel (see Section 2.2.1) and the hidden panel (see Section 2.2.3).

MODULE NUMBER X  
FAULT

This message indicates that the core controller of the selected module (UPS module or SSC, see Section 2.2.2) is sending invalid data to the alphanumeric display. The status of the module is still correctly indicated by the LEDs of the visible panel (see Section 2.2.1) and the hidden panel (see Section 2.2.3).

DISPLAY NUMBER X  
UNAVAILABLE

This message indicates that the alphanumeric display is not operating properly. The status of the UPS module or SSC is still correctly indicated by the LEDs of the visible panel (see Section 2.2.1) and the hidden panel (see Section 2.2.3).

# EPS 6000 UPS Shared Systems

---

*(this page intentionally left blank)*

---

# Maintenance and Service

---

**3.0 Scope** This section describes maintenance of the EPS 6000 UPS, including safety instructions, preventive maintenance, descriptions of replacement parts kits, and service.

## 3.1 Safety Instructions

### IMPORTANT SAFETY INSTRUCTIONS FOR SERVICING BATTERIES

- A. Servicing of batteries should be performed or supervised by personnel knowledgeable of batteries and the required precautions. Keep unauthorized personnel away from batteries.
- B. When replacing batteries, use the same model and manufacturer of batteries.
- C. CAUTION — Do not dispose of battery or batteries in a fire. The battery may explode.
- D. CAUTION — Do not open or mutilate the battery or batteries. Released electrolyte is harmful to the skin and eyes. It may be toxic.
- E. CAUTION — A battery can present a risk of electrical shock and high short-circuit current. The following precautions should be observed when working with batteries:
  - 1. Remove watches, rings, or other metal objects.
  - 2. Use tools with insulated handles.
  - 3. Wear rubber gloves and boots.
  - 4. Do not lay tools or metal parts on top of batteries.
  - 5. Disconnect charging source prior to connecting or disconnecting battery terminals.
  - 6. Determine if the battery is inadvertently grounded. If inadvertently grounded, remove the source of ground. Contact with any part of a grounded battery can result in electrical shock. The likelihood of such shock will be reduced if such grounds are removed during installation and maintenance.

## 3.2 Preventive Maintenance

The following preventive maintenance routines should be considered the minimum requirements; your installation and site may require additional preventive maintenance to assure optimal performance from your installed EPS 6000 UPS and associated equipment. These routines should be performed twice a year (more often if required). We strongly recommend contracting MGE Customer Support Services for preventive and remedial maintenance.

The technician or electrician performing preventive maintenance on the UPS must be familiar with the indicators, controls, and operation of the UPS, as described in this manual.

# EPS 6000 UPS Shared Systems

---

- a. Isolate and de-energize all EPS 6000 UPS equipment for all maintenance operations.
- b. Ensure that all equipment is clean and free of loose dust, dirt, and debris. The exterior of all enclosures may be cleaned with a mild solution of soap and water, lightly applied with a lint-free cloth.
- c. Inspect the air intake and exhaust plates and clean as required. Verify that air flows freely through the equipment. Clean the air intake and exhaust plates, and the enclosure interior, with a vacuum cleaner.
- d. The EPS 6000 UPS module is equipped with air filters that should be changed at regular intervals. Inspect the filters regularly to determine how long the filters will last in your installation.
- e. Initiate the start-up procedure, as described in Section 2.4.1.
- f. Test the main operating sequences as applicable to your equipment configuration and installation.

## 3.3 Replacement Parts

There are no user replaceable parts inside the EPS 6000 UPS.

Three levels of replacement parts are available for the EPS 6000 UPS. The three levels are designated A, B, and C. The level that you should keep on hand for your installation will vary depending on the type of maintenance planned on site, and the configuration of your UPS system. Having the replacement parts on hand will prevent any unacceptable delays (due to time involved obtaining spare parts) during critical periods, such as system start-up. Any items used during start-up will be replaced by MGE at no charge. Contact MGE Customer Support Services for specific recommendations. A description of each level is provided below:

Level	Description
A	This level of replacement parts consists of consumable items, specifically fuses and air filters. It is recommended to have these items on hand during installation of the UPS systems, including initial start-up.
B	This level of replacement parts is recommended when the user can tolerate short-duration UPS down-time to obtain replacement parts in the event of a major UPS failure. This level of replacement parts consists of consumable items, specifically fuses, air filters, an inverter leg, and the most critical circuit board assemblies.
C	This level of replacement parts is recommended when the user can tolerate only a minimum of down-time in the event of a major UPS failure. This level of replacement parts consists of consumable items, specifically fuses, air filters, an inverter leg, and a complete set of circuit board assemblies.



### 3.4 Troubleshooting and MGE Servicing

Should you encounter a problem in the operation of a UPS module and need MGE UPS Systems, Inc. to service your product, please take into account the following recommendations.

To the extent that you feel comfortable with the unit, leave it in its current state, make a record of the display lights and alarm messages and call either your local MGE Field Engineer or MGE's Customer Support Services at 1-800-438-7373 for assistance. Leaving the unit in its current state will enable MGE's field engineers to troubleshoot your product and bring it back on line more easily.

If you are not comfortable with the current status of the unit, you may want to take the following actions (listed by order of increasing impact on ease of troubleshooting):

1. If the audible alarm is active, reset it by pressing the audible alarm reset button (the second button from the left on the lower hidden panel as shown in Figure 2-8).
2. Stop the inverter (see Section 2.4.4.2 for normal shutdown and Section 2.4.6.3 for forced shut down).
3. Open the isolation circuit breaker Q5N.
4. Open the battery circuit breaker(s) QF1.
5. Reset the alarms by pressing the fault log clear button (the left most button on the lower hidden panel as shown in Figure 2-8).
6. Open the input isolation circuit breaker Q1 or the upstream circuit breaker feeding Q1.

After taking these steps, make a record of the display lights and alarm messages, call your local MGE Field Engineer or call 1-800-438-7373 for assistance.

# EPS 6000 UPS Shared Systems

---

*(this page intentionally left blank)*

---

# Glossary

---

## Symbols

¶	Used to reference paragraph headings that are listed in the table of contents.
/	Used to represent “and/or.”
%	Percent; of each hundred.
° F.	Degrees Fahrenheit.
° C	Degrees Celsius.
@	At.
±	Plus or minus.
#	Number.
∅	Phase.
Ω	Ohms.
2nd	Second.
A, B, C	Normal sequence of phases (clockwise) in three-phase power.
AC or ac	Alternating current.
<b>Alphanumeric display</b>	The LCD display above the hidden panel (behind the drop-down cover) on the UPS module and the SSC.
<b>Ambient air temperature</b>	The temperature of the surrounding air.
<b>Ambient noise</b>	The noise level of the environment.
<b>Attached load</b>	The load attached to the UPS output, such as a computer system or manufacturing system.
<b>Audible alarm</b>	A buzzer, located behind the front panel on the UPS module and the SSC, that sounds when alarm conditions occur.
<b>AWG</b>	American Wire Gauge, formerly Brown & Sharp gauge.

## EPS 6000 UPS Shared Systems

---

<b>B or BAT. or BATT.</b>	Battery.
<b>Breaker</b>	Circuit breaker.
<b>British Thermal Unit</b>	A unit of heat equal to 252 calories (see BTU).
<b>BTU or Btu</b>	British thermal unit. Defined as the amount of energy required to raise the temperature of 1 pound of water by 1° F.
<b>BYP</b>	Bypass.
<b>BYPASS</b>	Maintenance bypass; wrap-around manual maintenance bypass using the optional bypass circuit breaker Q3BP in conjunction with circuit breaker Q4S and isolation circuit breaker Q5N.
<b>Bypass AC input</b>	Mains 2.
<b>Calorie</b>	A unit of heat. One calorie is the amount of energy required to raise the temperature of one gram of water by one degree Celsius.
<b>Carrier</b>	The company or individual responsible for delivering goods from one area to another.
<b>CB</b>	Circuit breaker.
<b>Conduit</b>	A flexible or rigid tube surrounding electrical conductors.
<b>C.S.S.</b>	Customer Support Services.
<b>CT</b>	Current transformer.
<b>Curr.</b>	Current.
<b>Current rating</b>	The maximum current that a piece of electrical equipment is designed to carry.
<b>DC or dc</b>	Direct current.
<b>Earth ground</b>	A ground circuit that has contact with the earth.
<b>Electrician</b>	Refers to an installation electrician qualified to install heavy-duty electrical components in accordance with local codes and regulations. Not necessarily qualified to maintain or repair electrical or electronic equipment. Compare to technician.
<b>EPO</b>	Emergency power off.

<b>Free running</b>	Indicates that the inverter frequency is stable and independent of the bypass AC input (mains 2) frequency.
<b>FREQ</b>	Frequency.
<b>Fusible</b>	Capable of being melted with heat.
<b>GND</b>	Ground
<b>Hz</b>	Hertz, a measure of frequency; one cycle per second equals one Hertz.
<b>I</b>	Current.
<b>Input branch circuit</b>	The input circuit from the building power panel to the equipment.
<b>Inverter</b>	An electrical circuit that generates an AC sinewave output from a DC input.
<b>kVA</b>	Kilovolt-Ampere; a measure of apparent power.
<b>kW</b>	Kilowatt; a measure of real power.
<b>LCD</b>	Liquid-crystal display.
<b>LED</b>	Light-emitting diode.
<b>LEG or Leg</b>	Inverter leg.
<b>Load protected</b>	The attached load is being supplied by the UPS module inverter output, and the battery is available in the event that incoming (utility) power is lost.
<b>Load not protected</b>	The attached load is being supplied, but the battery system is unavailable.
<b>Low battery shutdown</b>	The battery has reached the lowest permitted operating voltage, and the inverter has shut down (disconnecting the load) to protect the battery from damage due to further discharge.
<b>Mains or mains 1</b>	Main AC input source.
<b>Mains 2</b>	Bypass AC input source.
<b>MAX</b>	Maximum.
<b>MBC</b>	Optional maintenance bypass cabinet that attaches to the SSC (in shared systems).

## EPS 6000 UPS Shared Systems

---

<b>MCM</b>	Thousand circular mil; standard wire sizes for multiple stranded conductors over 4/0 AWG in diameter. M is from the Roman numeral system; it is the symbol for 1,000.
<b>MG</b>	Motor-generator set.
<b>MGE</b>	MGE UPS Systems, Inc.
<b>module</b>	Refers to an EPS 6000 UPS module (rectifier/battery charger, inverter, and attached battery cabinet).
<b>MOV</b>	Metal-oxide varistor.
<b>NEC</b>	National electrical code.
<b>NFPA</b>	National fire protection association.
<b>NO. or No.</b>	Part number.
<b>OSHA</b>	Occupational safety and health act.
<b>OF</b>	Over-frequency.
<b>On-battery operation</b>	The attached load is being supplied by the stored energy in the battery system.
<b>OV</b>	Over-voltage.
<b>Packing list</b>	The list of articles included in a given shipment.
<b>P.F.</b>	Power factor.
<b>Q1</b>	UPS input isolation circuit breaker.
<b>Q3BP</b>	Optional maintenance bypass circuit breaker (in single-module UPS system); optional maintenance bypass circuit breaker in MBC cabinet (in shared systems).
<b>Q4S</b>	Control or bypass circuit breaker (in single-module UPS systems); user-supplied bypass AC input circuit breaker supplying the SSC (in shared systems).
<b>Q5N</b>	Optional UPS isolation circuit breaker (in single-module UPS systems); UPS module isolation circuit breaker (in shared systems); optional SSC isolation circuit breaker (in MBC).
<b>QF1</b>	Battery disconnect circuit breaker.

<b>Remote emergency power off</b>	A switch used for shutting down electrical equipment from a location away from the equipment.
<b>REPO</b>	Remote emergency power off.
<b>SCR</b>	Silicon-controlled rectifier.
<b>Security bypass (key)</b>	Pushbutton on the hidden panel (UPS modules and SSC) allowing forced transfers and other commands to be issued. The security key pushbutton must be held down while the desired function is executed.
<b>SEQ</b>	Sequence.
<b>Shipping damage</b>	Any damage done to an article while it is in transit.
<b>Shipping pallet</b>	A platform on which articles are fixed for shipping.
<b>Specific gravity</b>	The ratio of the weight of a given volume of substance (such as electrolyte) to that of an equal volume of another substance (such as water) used as a reference.
<b>SSC</b>	Static switch cabinet (in shared systems).
<b>Sync or synch</b>	Synchronization.
<b>Technician</b>	Refers to an electronic technician qualified to maintain and repair electronic equipment. Not necessarily qualified to install electrical wiring. Compare with electrician.
<b>Test connector</b>	DB-9 type connector on the hidden panel (UPS modules and SSC) allowing an MGE Customer Support Services technician to access programmable and diagnostic features of the system.
<b>U</b>	Voltage.
<b>UF</b>	Under frequency.
<b>UL</b>	Underwriters Laboratories, Inc.
<b>UPS</b>	Uninterruptible power system.
<b>UV</b>	Under voltage.
<b>VAC</b>	Volts of alternating current.
<b>Vb</b>	Battery voltage (in volts DC).

## EPS 6000 UPS Shared Systems

---

<b>VDC</b>	Volts of direct current.
<b>Via</b>	By way of.
<b>VPC</b>	Volts per cell, the measure of the electrical potential of a storage cell, such as a battery.
<b>XFMR</b>	Transformer.



---

# Reorder form

---



1660 Scenic Avenue  
Costa Mesa, CA 92626

**Use this form** to order additional copies of this document, or to report any errors, omissions, or other problems you have experienced.

NAME \_\_\_\_\_

COMPANY \_\_\_\_\_

STREET ADDRESS \_\_\_\_\_

CITY \_\_\_\_\_ STATE \_\_\_\_\_ ZIP \_\_\_\_\_

I would like to order \_\_\_\_\_ (quantity @ \$50.00 each) additional copies of the:

**EPS 6000 UPS User's Guide,  
Shared Systems  
86-130034-00**

I would like to report the following problems with this document:

---

---

---

---

---

---

---

---

---

---





**M G E**  
UPS SYSTEMS



*Nothing will stop you now™*

1660 Scenic Avenue, Costa Mesa, California 92626 ▪ (714) 557-1636 ▪ [www.mgeups.com](http://www.mgeups.com)

## Free Manuals Download Website

<http://myh66.com>

<http://usermanuals.us>

<http://www.somanuals.com>

<http://www.4manuals.cc>

<http://www.manual-lib.com>

<http://www.404manual.com>

<http://www.luxmanual.com>

<http://aubethermostatmanual.com>

Golf course search by state

<http://golfingnear.com>

Email search by domain

<http://emailbydomain.com>

Auto manuals search

<http://auto.somanuals.com>

TV manuals search

<http://tv.somanuals.com>