



OWNER'S MANUAL
MANUAL DE INSTRUCCIONES

Memorex®

**DC POWER
VIDEO CASSETTE PLAYER
CD ENERGIA
REPRODUCTOR DE VIDEO**

MVP0028

ENGLISH

ESPAÑOL

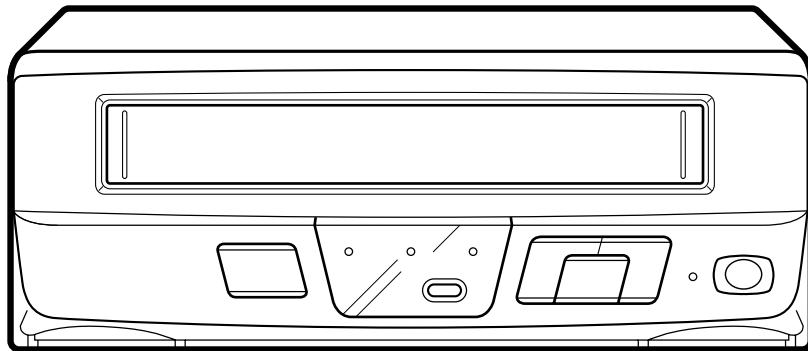

**IMPORTANT NOTICE
IMPORTANTE AVISO**

TO PREVENT DAMAGE TO THE TAPE, ALWAYS TURN OFF VCP FIRST
BEFORE YOU SWITCH ON OR OFF THE CAR ENGINE IGNITION.

TO PREVENT DAMAGE TO THE TAPE, ALWAYS TURN OFF VCP FIRST
BEFORE YOU SWITCH ON OR OFF THE CAR ENGINE IGNITION.

Tr S1



Before operating the unit, please read this manual thoroughly.
Antes de utilizar su aparato favor de leer las siguientes instrucciones.





ENGLISH

	CAUTION RISK OF ELECTRIC SHOCK DO NOT OPEN	
<p>CAUTION: TO REDUCE THE RISK OF ELECTRIC SHOCK, DO NOT REMOVE COVER (OR BACK). NO USER-SERVICEABLE PARTS INSIDE. REFER SERVICING TO QUALIFIED SERVICE PERSONNEL.</p>		



The lightning flash with arrowhead symbol, within an equilateral triangle is intended to alert the user to the presence of uninsulated dangerous voltage within the product's enclosure that may be of sufficient magnitude to constitute a risk of electric shock.



The exclamation point within an equilateral triangle is intended to alert the user to the presence of important operating and maintenance (servicing) instructions in the literature accompanying the appliance.

CAUTION: Changes or modifications not expressly approved by the party responsible for compliance with the FCC Rules could void the user's authority to operate this equipment.

WARNING: TO PREVENT FIRE OR SHOCK HAZARD, DO NOT EXPOSE THIS APPLIANCE TO RAIN OR MOISTURE.

NOTE:

Please keep all packaging material for at least 90 days in case you need to return this product to your place of purchase or Memorex.





IMPORTANT SAFEGUARDS

1. READ INSTRUCTIONS

All the safety and operating instructions should be read before the unit is operated.

2. RETAIN INSTRUCTIONS

The safety and operating instructions should be retained for future reference.

3. HEED WARNINGS

All warnings on the unit and in the operating instructions should be adhered to.

4. FOLLOW INSTRUCTIONS

All operating and use instructions should be followed.

5. CLEANING

Unplug this unit from the wall outlet before cleaning. Do not use liquid cleaners or aerosol cleaners. Use a damp cloth for cleaning the exterior cabinet only.

6. ATTACHMENTS

The manufacturer of this unit does not make any recommendations for attachments, as they may cause hazards.

7. WATER AND MOISTURE

Do not use this unit near water. For example, near a bathtub, washbowl, kitchen sink, laundry tub, in a wet basement, or near a swimming pool.

8. ACCESSORIES

Do not place this unit on an unstable cart, stand, tripod, bracket, or table. The unit may fall, causing serious injury, and serious damage to the unit.

- 8A. An appliance and cart combination should be moved with care. Quick stops, excessive force, and uneven surfaces may cause the appliance and cart combination to overturn.

PORTABLE CART WARNING
(symbol provided by RETAC)



S3125A

9. VENTILATION

Slots and openings in the cabinet back or bottom are provided for ventilation, to ensure reliable operation of the unit and to protect it from overheating. These openings must not be blocked or covered. The openings should never be blocked by placing the unit on a bed, sofa, rug, or other similar surface. This unit should never be placed near or over a radiator or heat source. This unit should not be placed in a built-in installation, such as a bookcase, or rack unless proper ventilation is provided or the manufacturer's instructions have been adhered to.

10. POWER SOURCE

This unit should be operated only from the type of power source indicated on the rating plate. If you are not sure of the type of power supply to your home, consult your appliance dealer or local power company. For units intended to operate from battery power, or other sources, refer to the operating instructions.

11. GROUNDING OR POLARIZATION

This unit is equipped with a polarized alternating current line plug (a plug having one blade wider than the other). This plug will fit into the power outlet only one way. This is a safety feature. If you are unable to insert the plug fully into the outlet, try reversing the plug. If the plug should still fail to fit, contact your electrician to replace your obsolete outlet. Do not defeat the safety purpose of the polarized plug. If your unit is equipped with a 3-wire grounding-type plug, a plug having a third (grounding) pin, this plug will only fit into a grounding-type power outlet. This too, is a safety feature. If you are unable to insert the plug into the outlet, contact your electrician to replace your obsolete outlet. Do not defeat the safety purpose of the grounding-type plug.

12. POWERCORD PROTECTION

Power-supply cords should be routed so that they are not likely to be walked on or pinched by items placed upon or against them, paying particular attention to cords at plugs, convenience receptacles, and the point where they exit from the appliance.

13. LIGHTNING

To protect your unit during a lightning storm, or when it is left unattended and unused for long periods of time, unplug it from the wall outlet and disconnect the antenna or cable system. This will prevent damage to the unit due to lightning and power line surges.



IMPORTANT SAFEGUARDS (CONTINUED)

14. POWER LINES

An outside antenna system should not be located in the vicinity of overhead power lines, or other electric light or power circuits, or where it can fall into such power lines or circuits. When installing an outside antenna system, extreme care should be taken to keep from touching such power lines or circuits as contact with them might be fatal.

15. OVERLOADING

Do not overload wall outlets and extension cords as this can result in a risk of fire or electric shock.

16. OBJECT AND LIQUID ENTRY

Do not push objects through any openings in this unit as they may touch dangerous voltage points or short out parts that could result in fire or electric shock. Never spill or spray any type of liquid into the unit.

17. OUTDOOR ANTENNA GROUNDING

If an outside antenna or cable system is connected to the unit, be sure the antenna or cable system is grounded to provide some protection against voltage surges and built-up static charges. Section 810 of the National Electrical Code, ANSI/NFPA 70, provides information with respect to proper grounding of the mast and supporting structure, grounding of the lead-in wire to an antenna discharge unit, size of grounding conductors, location of antenna discharge unit, connection to grounding electrodes, and requirements for the grounding electrode.

18. SERVICING

Do not attempt to service this unit yourself as opening or removing covers may expose you to dangerous voltage or other hazards. Refer all servicing to qualified service personnel.

19. DAMAGE REQUIRING SERVICE

Unplug this unit from the wall outlet and refer servicing to qualified service personnel under the following conditions:

- a. When the power-supply cord or plug is damaged.
- b. If liquid has been spilled, or objects have fallen into the unit.
- c. If the unit has been exposed to rain or water.
- d. If the unit does not operate normally by following the operating instructions. Adjust only those controls that are covered by the operating instructions, as an improper adjustment of other controls may result in damage and will often require extensive work by a qualified technician to restore the unit to its normal operation.
- e. If the unit has been dropped or the cabinet has been damaged.
- f. When the unit exhibits a distinct change in performance, this indicates a need for service.

20. REPLACEMENT PARTS

When replacement parts are required, be sure the service technician uses replacement parts specified by the manufacturer or those that have the same characteristics as the original parts. Unauthorized substitutions may result in fire, electric shock or other hazards.

21. SAFETY CHECK

Upon completion of any service or repairs to this unit, ask the service technician to perform safety checks to determine that the unit is in proper operating condition.

22. WALL OR CEILING MOUNTING

If mounting this unit to a wall or ceiling follow the installation recommended by the manufacturer of a mounting bracket specifically designed for this type of product. Use only a mounting device that can handle the weight and size of your unit. Should your bracket require drilling holes into this unit, this would void the manufacturers warranty.

23. HEAT

The product should be situated away from heat sources such as radiators, heat registers, stoves, or other products (including amplifiers) that produce heat.

24. NOTE TO CATV SYSTEM INSTALLER

This reminder is provided to call the CATV system installer's attention to Article 820-40 of the NEC that provides guidelines for proper grounding and, in particular, specifies that the cable ground shall be connected to the grounding system of the building, as close to the point of cable entry as practical.



SAFETY PRECAUTIONS

Congratulations upon your selection of this MEMOREX Product. Be sure to read the following Safety Precautions before trying to use it for the first time.

ENGLISH

MOISTURE CONDENSATION

DO NOT OPERATE THIS VCP FOR AT LEAST TWO OR THREE HOURS WHEN MOISTURE IN THE AIR CONDENSES ON THE VCP.

■ WHAT IS MOISTURE CONDENSATION?

When a cold liquid is poured into a glass, for example, water vapor in the air will condense on the surface of the glass. This is called moisture condensation.

■ MOISTURE WILL CONDENSE ON THE UNIT IN THE FOLLOWING CASES;

- When you move this VCP from a cold to a warm place.
- After heating a cold room or under extremely humid conditions.

■ WHEN YOU EXPERIENCE THE ABOVE CONDITIONS,

The PLAY indicator will flash on and off and all the function buttons except the STOP/EJECT button are made nonoperational to protect the video heads.

In this case, take out the video cassette, leave the VCP turned on and let it remain at room temperature until moisture condensation disappears.

Depending on the surrounding conditions, this may take two or three hours.

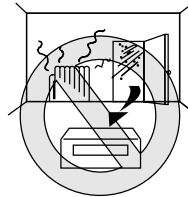
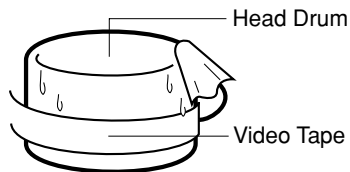

- If you cause a static discharge when touching the VCP, and the VCP fails to function, simply unplug the VCP from cigarette lighter socket, wait 10 minutes and plug it back in. The VCP should return to normal operation.
- Avoid extreme heat or cold. (41°F/5°C-104°F/40°C)
- Do not place the VCP on or near appliances which may cause electromagnetic interference, e.g. TV, speakers, etc. Doing so may cause erratic operation of the VCP including picture and/or sound distortion or noise.
- Do not place any objects (such as coins etc.) on the top of the VCP, which may result in the serious damage.
- Avoid extreme moisture and dust.
- The ventilation holes prevent overheating. Do not block or cover these holes. Especially avoid covering the holes with soft materials such as cloth or paper.
- Do not insert fingers or any other objects into the cassette loading slot. Do not spray cleaner or wax directly on the VCP or use forced air to remove dust.
- Keep the VCP away from flower vases, sinks, etc.
If liquids should be spilled into the VCP, serious damage will result. If you spill any liquids into the VCP, unplug the DC power cord immediately and consult qualified service personnel before attempting to use the VCP again.
- When you finish operating the VCP, always unload the cassette and turn off the power.

5





SAFETY PRECAUTIONS

(CONTINUED)

INSTALL THE VCP IN YOUR CAR

- For a car equipped with air bags, be sure to follow the manufacturer's instructions whenever performing any electrical wiring work. Incorrect wiring can cause the air bag system of a car to malfunction.
- Never cut the insulation from the power supply lead in an attempt to draw power for another device. Doing so can overload the current capacity of the lead, creating the danger of fire and electric shock.
- For proper installation and wiring special technical knowledge is required. If you have any doubts about where to position or how to install components, contact the retailer where you purchased the product, your automobile dealership, or an automotive service provider. Note that you will be charged separately for installation work.
- Use all of the components that come with this product only as directed. Improper use of components can damage interior components or result in improper anchoring of components, which creates the danger of accident and personal injury.
- Improper installation creates the danger of fire and accident.
- Take care so wires are not pinched between chassis parts, by screws, or by the seat as it slides on its rails, etc. Such conditions can cut wires and cause shorts, creating the danger of accident, electric shock, and fire.
- Avoid installation in areas subject to strong vibration and areas where secure anchoring cannot be achieved. Components installed in such areas can work loose, creating the danger of accident and personal injury.
- Never install the VCP on the dashboard or in any other location where it obstructs forward vision.
- Never attach the stand to the roof of your car. Doing so creates the danger of the VCP falling down.
- Never attach the stand to a sharply angled surface or to a surface that causes the VCP to face downwards. Such installation can cause the VCP to fall.
- Be sure to turn the ignition key of the car to the "OFF" position before connecting or disconnecting wires and cables. Failure to do so creates the danger of electric shock and personal injury.

DRIVING SAFETY

- Never watch the VCP or try to adjust settings while driving. Doing so creates the danger of traffic accident. Before operating the VCP, be sure to stop the car in a safe area.
- Never install the unit on the dashboard or in any other location where it obstructs forward vision. Items that obstruct forward vision in a motor car may be illegal.

6





Also, make sure that all components are installed where they do not interfere with operation of the steering wheel, shift lever, brake pedal, etc., for example under the driver's seat, and where they do not endanger passengers. Improper installation creates the danger of traffic accident and personal injury.

- Make sure all cables are bundled together so they do not interfere with car operation, as described in this manual. Improperly installed cables create the danger of entanglement with the steering wheel, shift lever, brake pedal, etc.

IMPORTANT NOTES:

- The unit is designed for use with a 12V DC automotive power supply. Never use it in a truck, bus, or any other car that has a 24V power supply.
- Be sure to stop your car in a safe area before watching or adjusting the VCP.
- Operating the VCP for a long time with the engine of your car stopped can run down your car's battery.
- Never leave the VCP in areas exposed to temperature extremes or strong direct sunlight. Leaving it in a closed car, in direct sunlight, near a heater, etc. can cause deformation of the case. Using this product in areas that are colder than 5°C (41°F) or hotter than 40°C (104°F) can result in poor image quality.
- Never use benzene or other chemical agents for cleaning. Chemicals can damage the case and remove markings. Use a soft cloth moistened with a weak solution of water and mild neutral detergent. Wring out all excess moisture from the cloth before wiping.
- Never drop the VCP or otherwise subject it to strong impact.
- Should the VCP ever begin to emit smoke, abnormal odor, or a strange noise, immediately turn off power and unplug the unit from the cigarette lighter socket. Continued use of the VCP under any of these conditions creates the danger of fire and electric shock.
- Do not continue to use the VCP if it is malfunctioning and does not produce a video image or sound. Whenever you notice such symptoms, immediately turn off power, unplug the VCP from the cigarette lighter socket. Continued use of the VCP creates the danger of fire and electric shock.
- When you leave your car unattended for long periods, be sure to unplug the VCP from the cigarette lighter socket. Leaving the VCP plugged in can run down the car's battery.



FEATURES

12V DC Operation - This VCP is designed to operate from a 12V DC car cigarette lighter.

2 Speed Picture Search - 3 or 5 times normal speed in SP mode (5 X or 7 X in LP and 7 X or 9 X in SLP).

Automatic Power On - Playback - Rewind - Stop - Eject - Power Off - When loading the cassette tape, this unit will automatically turn on and play back the cassette tape at the correct speed. When the tape reaches the end, it will automatically stop, rewind, stop, eject the tape and the unit will turn off.

Full Load Tape Transport - Permits rapid access between modes.

Automatic Repeat Play System - When you press the REPEAT button, this unit will automatically play back the same cassette tape repeatedly.

Digital Auto Tracking - Automatically adjusts tracking during playback for the best possible picture.

Audio/Video Output Jacks - These jacks permit connection to a VCR or Monitor/TV for better picture quality or for duplicating video tapes.

This Unit May Be Remote Controlled With The Unified TV/VCP Remote Controller.

***This model is designed for Video Cassette playback. Recording is not possible.**

TABLE OF CONTENTS

PREPARATION

IMPORTANT SAFEGUARDS	3
SAFETY PRECAUTIONS	5
FEATURES/TABLE OF CONTENTS	8
LOCATION OF CONTROLS	9
CONNECTION TO YOUR TV	10
POWER SOURCE	11
SETTING THE VIDEO CHANNEL	12

PLAYBACK

LOADING AND UNLOADING THE VIDEO CASSETTE TAPE	13
PLAYBACK	14
SPECIAL EFFECTS	16

ADDITIONAL INFORMATION

BEFORE REQUESTING SERVICE	17
VIDEO HEAD CLEANING	18
SPECIFICATIONS	19





LOCATION OF CONTROLS

FRONT

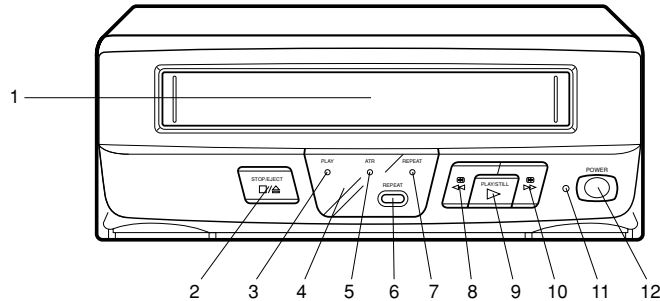

REAR

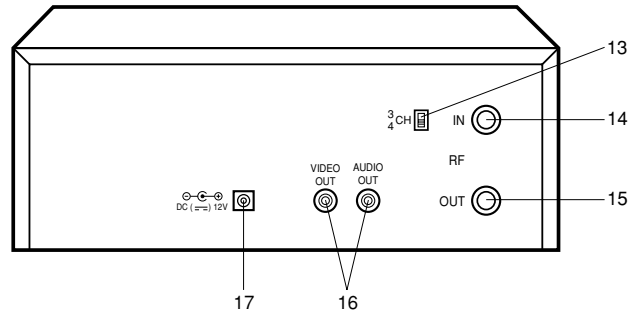

ENGLISH

DESCRIPTIONS OF BUTTONS AND REAR PANEL CONNECTORS

FRONT

1. **Cassette Loading Slot** - To insert or remove a video tape.
2. **STOP/EJECT button** - Press once to stop the tape in any mode. Press again to eject the tape.
3. **PLAY indicator** - This lights when the PLAY feature is activated.
When moisture condenses on the VCP, the PLAY indicator will flash on and off.
4. **Remote Sensor** - Signals from the Remote Control are received here.
5. **ATR (AUTO TRACKING) indicator** - This lights when the DIGITAL AUTO TRACKING feature is activated.
6. **REPEAT button** - When pressed, the VCP will play back the tape over and over until stopped manually.
7. **REPEAT indicator** - This lights when the REPEAT feature is activated.
8. **REW (Rewind) button** - In the STOP mode, this button rapidly winds the tape backwards. In the PLAY mode, this button activates Reverse Search.
9. **PLAY/STILL button** - When pressed in the STOP mode, the tape begins playback. If pressed during playback, it pauses the tape and displays a still picture on the TV screen.

10. **F.FWD (Fast Forward) button** - In the STOP mode, this button rapidly winds the tape forward. In the PLAY mode, this button activates Forward Search.
11. **POWER indicator** - This lights when the power is on. **Or will flash on and off to take up any tape slack at the power recovery after the power interruption of tape rewind or forward mode.**
12. **POWER button** - Turns the VCP power on and off.

REAR

13. **3/4 Channel Selector switch** - Selects the channel through which the VCP outputs its signal to a TV.
14. **RF IN jack** - Connect a VHF/UHF antenna or CATV cable to this jack.
15. **RF OUT jack** - Used to output VHF/UHF or CATV signals to a TV.
16. **AUDIO/VIDEO OUT jacks** - Used to output audio and video signals to a TV, amplifier or VCR.
17. **DC Input jack** - Connect the 12V DC car cord (supplied) here for DC operation.



CONNECTION TO YOUR TV

Below are 2 common methods of connecting your VCP to a TV.

BASIC CONNECTIONS

The VCP must be connected "between" the antenna, and the TV. First, disconnect the antenna from the TV and connect it to the VCP. Then connect the VCP to the TV. After you have connected the antenna to the VCP, you must connect the VCP to the TV.

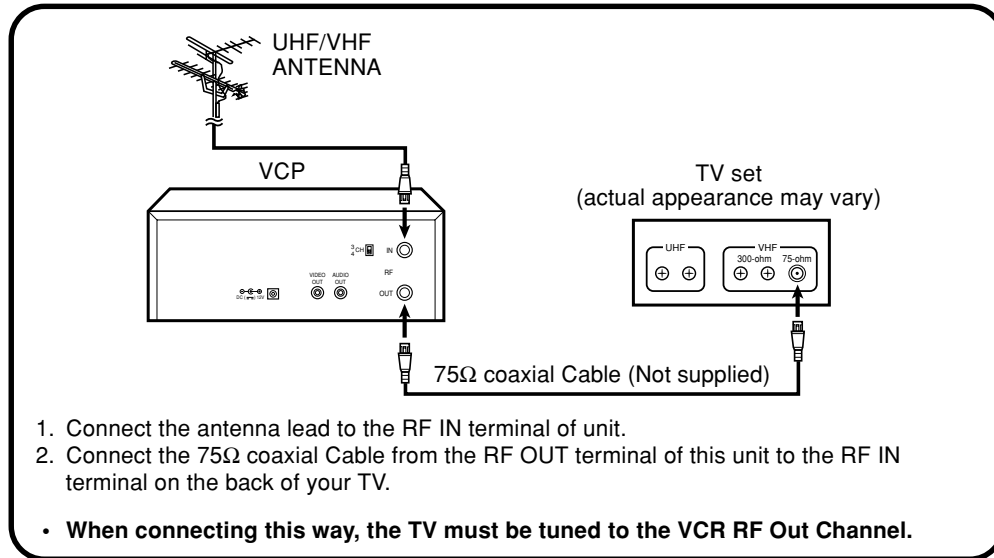

CONNECTION TO A TV WITH AUDIO/VIDEO JACKS

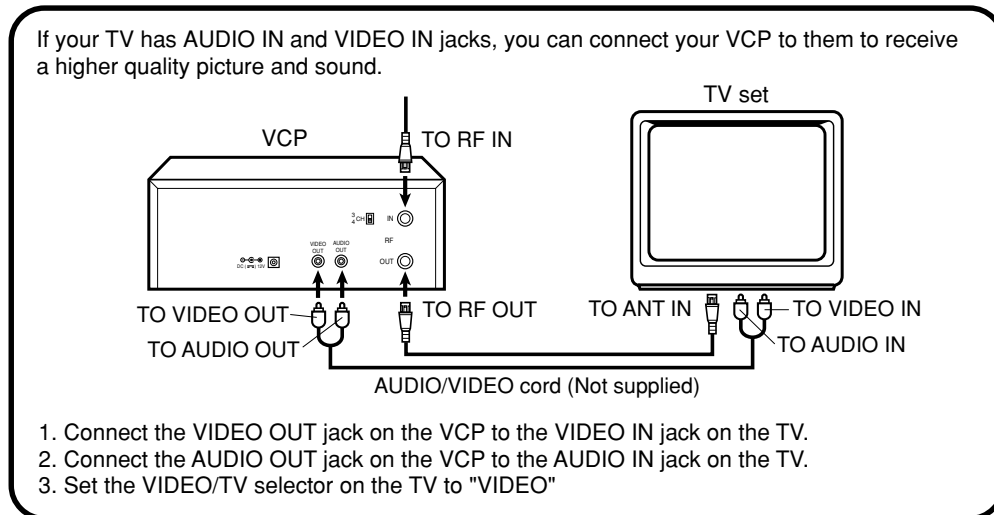

NOTE: CONNECTION TO A CATV

The VCP must be connected "between" the cable from cable company and the TV. First, disconnect the cable from the TV and connect it to the VCP. Then connect the VCP to the TV.





POWER SOURCE

DC POWER SUPPLY

A DC car cord is supplied with the unit.

The car cord has been designed for use with external DC power (12 volt with negative ground).

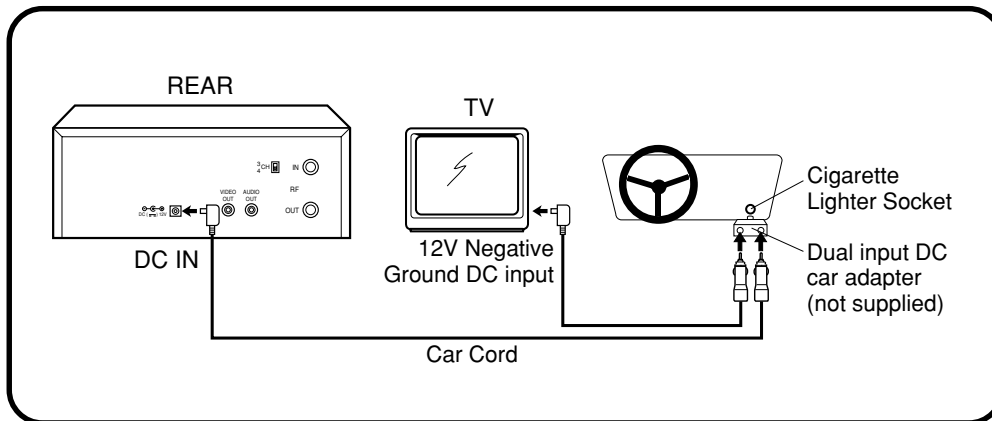

ENGLISH

Plug one small plug into the DC input jack on the rear of the VCP, then plug into the one jack of the Dual input DC car adapter (not supplied) connected to the car cigarette lighter socket. If you use a TV with DC power, connect to another jack of a dual input DC car adapter.

Make sure that the cord makes a firm connection. It may be necessary to try several insertions, rotating the plug for proper electrical connection.

NOTE: • ALWAYS TURN OFF VCP FIRST BEFORE SWITCH ON OR OFF THE IGNITION OF CAR ENGINE.

- Make sure that the negative terminal of the battery is grounded. This set is designed for use with negative ground system only.
- Use the supplied car cord only.
- When the VCP is not in use, always disconnect it from the car cigarette lighter socket to avoid a battery drain.
- If the VCP is to be directly connected to a 12V DC power source, for example, recreational vehicle (RV) applications, make sure the power cord is connected after the ignition switch to avoid battery drain.
- Do not operate the VCP if the car battery is weak. Peak current from the car alternator could blow the DC fuse.
- In case of connecting to the TV (Memorex MT1098), refer to its owner's manual.
- Check the battery's charge level regularly when the VCP is used in a vehicle.

REPLACING THE FUSE IN THE CAR BATTERY CORD PLUG

If the fuse in the car battery cord plug blows, replace it with a new 8 A fuse (Fast Blow Type) as shown below. Unscrew the tip of the plug to remove.

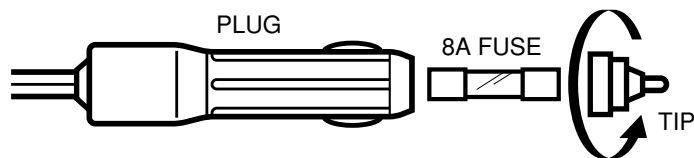

11





SETTING THE VIDEO CHANNEL

To view playback of a recorded tape, the TV must be set to channel 3 or 4 (video channel). The VCP 3/4 Channel Selector switch must also be set to channel 3 or 4 as shown below. If you have used a Audio/Video cable you should not have to follow this procedure. Simply select the VIDEO mode on your TV.

1 Press the POWER button to turn the unit on.



2 Set the 3/4 Channel selector switch to CH 3 or 4.

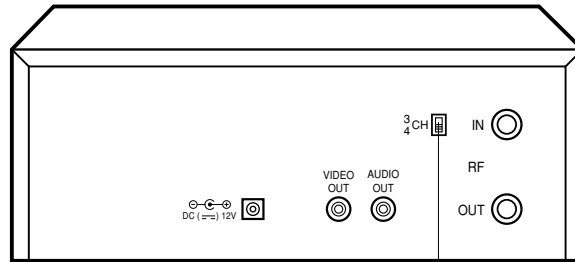
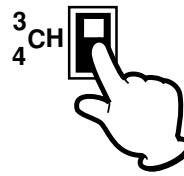

2

3 Turn ON the TV and set to CH3 or 4 to correspond with the channel selector in **2**.

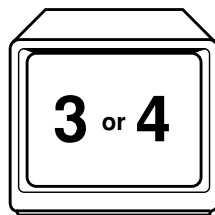

For a push-button TV tuner

If CH 3 or 4, corresponding to the video channel cannot be tuned on your TV, or is not broadcasting in your area, proceed as follows: set the VCP 3/4 channel selector switch and the TV to CH 3 or 4. Playback a prerecorded tape and tune the TV to receive a sharp color picture from the video cassette player. Refer to your TV owner's manual for details.

12





LOADING AND UNLOADING THE VIDEO CASSETTE TAPE

Use only video cassette tapes marked **VHS**.

LOADING

Gently push the center of the tape until it is automatically retracted.

AUTOMATIC POWER ON AND PLAY

When loading a cassette tape, this video cassette player will turn on automatically and playback will start immediately. The POWER, and PLAY indicators will light.

Insert the cassette with its labeled side facing you. An inverted cassette cannot be inserted.

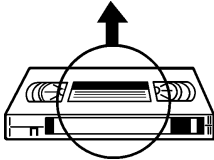

ENGLISH

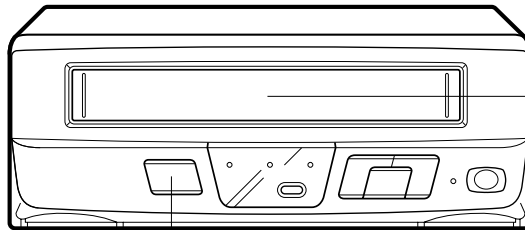

1

2

UNLOADING

1

To unload a cassette, press the STOP/EJECT button in the STOP mode.



AUTOMATIC EJECT

If the video cassette player automatically rewinds the tape to the beginning (AUTO REWIND FEATURE), the tape will be ejected automatically.

2

Remove the cassette.

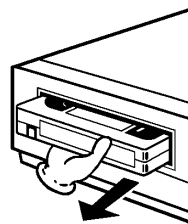

NOTE:



- Always eject the tape when not in use.
- The cassette can be ejected even if the POWER button is "OFF".



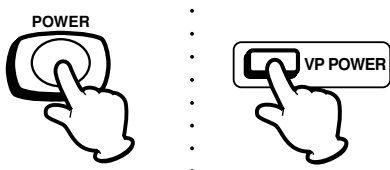

PLAYBACK

TO START PLAYBACK

<p>1 Press the POWER button on the unit or on the remote control to turn the unit on and set the TV to the Video position.</p> 	<p>2 Load a prerecorded tape. (When loading a cassette tape, the video cassette player will turn on, the PLAY indicator will light and playback will start automatically.)</p> 
---	--

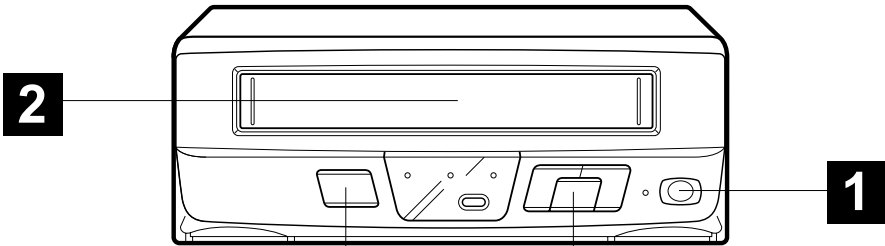

TO STOP PLAYBACK

Press the STOP/EJECT button (or the STOP button on the Remote Control) once. The tape will stop but remain fully loaded and ready to play. If you are not going to resume play, press the STOP/EJECT button to eject a tape.

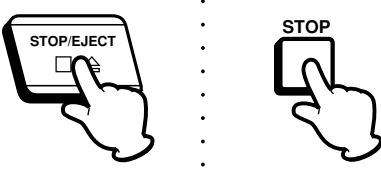

TO START PLAYBACK AGAIN

Press the PLAY/STILL button (or the PLAY button on the Remote Control) once.

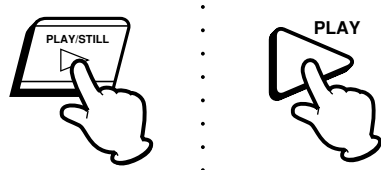

NOTE: To prevent damage to the tape, always turn off VCP first before you switch on or off the car engine ignition.





TO REWIND OR FORWARD THE TAPE RAPIDLY

Press the REW button in the STOP mode.



If you want to see the tape program during REW mode, press and hold the REW button. The backward visual search picture will be seen on the screen. Release to return to the REW mode.

Press the F.FWD button in the STOP mode.



If you want to see the tape program during FWD mode, press and hold the F. FWD button. The forward visual search picture will be seen on the screen. Release to return to the FWD mode.

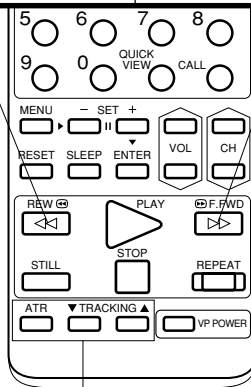

DIGITAL TRACKING CONTROLS

When a tape is played, the Digital Auto Tracking System automatically adjusts the tracking to obtain the best possible picture. The ATR (AUTO TRACKING) indicator blinks while the system is searching for optimum tracking. The ATR indicator stops blinking and remains lit as long as automatic tracking continues. If noise bars appear during playback, adjust the tracking manually;

- Press the TRACKING ▲ or ▼ button to obtain the best possible picture. To resume automatic tracking, press the ATR button.





SPECIAL EFFECTS

TO VISUALLY SEARCH FOR DESIRED POINTS

When either the F.FWD or REW button is pressed in the PLAYBACK mode, the speed search picture will appear. When pressed twice, the search picture will increase speed. Speed search time depends upon the speed used (SP, LP or SLP) during recording. See chart below.

To rewind or fast forward a tape, press the STOP button, and then press the REW or F.FWD button.

To visually search backward, press the REW button once or twice in the PLAYBACK mode.



Press the PLAY button (or the PLAY/STILL button on the VCP) once to resume normal viewing speed.

To visually search forward, press the F.FWD button once or twice in the PLAYBACK mode.



Press the PLAY button (or the PLAY/STILL button on the VCP) once to resume normal viewing speed.

SPEED SEARCH TIMES

TAPE SPEED	PICTURE SEARCH SPEED	
	PRESS ONCE	PRESS TWICE
SP (Standard Play)	3 X	5 X
LP (Long Play)	5 X	7 X
SLP (Super Long Play)	7 X	9 X

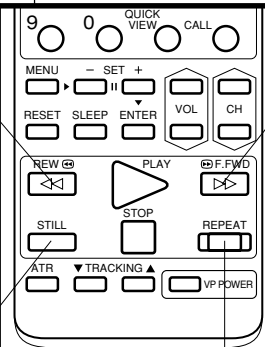

TO WATCH A STILL PICTURE

Press the STILL button (or the PLAY/STILL button on the VCP) in the PLAYBACK mode.



Press the PLAY button on the Remote Control or the PLAY/STILL button on the VCP once to resume normal playback.

TO WATCH A TAPE REPEATEDLY

Press the REPEAT button (the REPEAT indicator will light) and the tape will play over and over until the repeat mode is cancelled. To cancel repeat mode, press this button again.

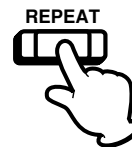

- NOTE:**
- Best results during speed search playback can be obtained with cassette tapes recorded in the "SLP" mode.
 - The audio output is muted during SPEED SEARCH and STILL.
 - A few noise bars will appear on the picture during SPEED SEARCH.
 - To prevent damage to the tape, STILL playback is automatically changed to the PLAYBACK mode after 5 minutes.





BEFORE REQUESTING SERVICE

Check the following chart for the symptom(s) you are experiencing.

SYMPTOMS	CAUSES	POSSIBLE SOLUTIONS	PAGE
POWER			
No power	The DC car cord is not plugged into the cigarette lighter socket.	Connect the DC car cord to the cigarette lighter socket.	11
	The DC car cord fuse is blown.	Replace the fuse.	11
Power is on-no operations	Cassette is not inserted.	Insert cassette.	13
	Moisture condenses on the video heads.	The PLAY indicator is flashing on and off. Wait two or three hours until it goes off.	5
PLAYBACK			
No picture when playing back a recorded tape.	The TV is not set to the Video channel 3 or 4.	Set the Video channel to 3 or 4 position on your TV. (When a TV is connected with an antenna cable)	12
Noise bars on the screen.	Tracking adjustment beyond range of automatic tracking circuit.	Adjust tracking manually using the TRACKING ▲ and ▼ buttons on remote control.	15
	Video heads are dirty.	Clean the video heads.	18
	The tape is worn or damaged.	Try another tape.	—

ENGLISH

Memorex®

FOR ADDITIONAL SET-UP OR OPERATING ASSISTANCE, PLEASE VISIT OUR WEBSITE AT WWW.MEMCORPINC.COM OR CONTACT CUSTOMER SERVICE AT 1-800-919-3647. PLEASE KEEP ALL PACKAGING MATERIAL FOR AT LEAST 90 DAYS IN CASE YOU NEED TO RETURN THIS PRODUCT TO YOUR PLACE OF PURCHASE OR MEMOREX. FOR PARTS AND ACCESSORIES, CONTACT FOX INT'L AT 1-800-321-6993.





VIDEO HEAD CLEANING

VIDEO HEAD CLOGGING

The video heads are the means by which the VCP reads pictures from the tape during playback. In the unlikely event that the heads become dirty enough to be clogged, no picture will be played back. This can easily be determined if, during playback of a known good tape, there is good sound, but no picture (picture is extremely snowy). If this is the case, have the video cassette player checked by qualified service personnel.



Good Picture

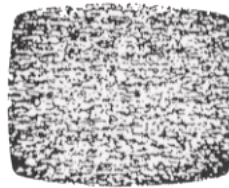

Snowy Picture

VIDEO HEAD CLEANING

Video head cleaning is needed when the playback picture becomes unclear. This signifies that the heads are getting dirty and can occur when playing poor quality or damaged tapes. If the heads require cleaning, use a equivalent high quality chemical non-abrasive (wet) head cleaning tape or have them cleaned professionally. If playing a head cleaning tape in the VCR once does not improve the picture, play it several times before requesting service.

DO NOT ATTEMPT TO CLEAN THE VIDEO HEADS OR SERVICE THE UNIT BY REMOVING THE TOP COVER.

NOTE:

- Video heads may eventually wear out and should be replaced when they fail to produce clear pictures.
- To help prevent video head clogging, use only good quality VHS tapes. Discard worn out tapes.





SPECIFICATIONS

Video Head:	2 Rotary Heads
Video Signal:	NTSC Color
Cassette Tape:	VHS
Audio Track:	1 Track
Video Output:	RCA 1Vp-p/75 ohm unbalanced
Audio Output:	RCA -8dB/1K ohm unbalanced
Tape Speed:	SP: 33.35 mm/sec LP: 16.67 mm/sec SLP: 11.12 mm/sec
F.FWD/REW Time:	2' 30" with T120 tape
Speed Search:	SP 3 & 5 X Normal Speed LP 5 & 7 X Normal Speed SLP 7 & 9 X Normal Speed
Power Sources:	12V DC
Power Consumption:	9.8W at DC 12V
Storage Temperature:	-20°C to 60°C (-4°F to 140°F)
Operating Temperature:	5°C to 40°C (41°F to 104°F)
Dimensions:	10 1/16"(W) X 12 3/8"(D) X 3 3/4"(H)
Weight:	6.6 lbs (3.0kg)
Accessory:	Car battery cord

ENGLISH

Specifications are subject to change without notice.

Free Manuals Download Website

<http://myh66.com>

<http://usermanuals.us>

<http://www.somanuals.com>

<http://www.4manuals.cc>

<http://www.manual-lib.com>

<http://www.404manual.com>

<http://www.luxmanual.com>

<http://aubethermostatmanual.com>

Golf course search by state

<http://golfingnear.com>

Email search by domain

<http://emailbydomain.com>

Auto manuals search

<http://auto.somanuals.com>

TV manuals search

<http://tv.somanuals.com>