

**VX3038**

**STEREO CASSETTE PLAYER**

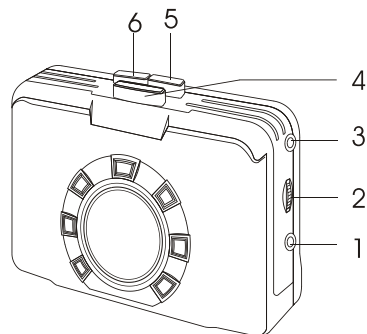

**OPERATING INSTRUCTIONS**

**CONTROLS**

1. PHONES jack
2. VOLUME control
3. DC IN 3V jack
4. PLAY button: ◀
5. STOP button: ■
6. F.FWD buttons: ◀◀

**POWER SUPPLY**

Batteries: 2 x " AA" batteries (UM-3/R6)  
(not included with this unit)

**NOTE:**

Replace the batteries if you hear distortion.

**PRECAUTIONS**

Incorrectly using batteries can cause them to leak or burst, and may damage your unit.

Note the following precautions:

- Be sure that the plus (+) and minus (-) poles are facing in the correct directions.
- Do not mix battery types.
- Do not mix new batteries with old ones.
- Never leave dead batteries in the battery compartment.
- Remove batteries when not using the unit for extended periods.
- Never try to recharge the batteries that are specified for the power supply of this unit.
- Do not expose batteries to direct

heat, let them become shorted or try to take them apart.(If a battery leaks, clean out the battery compartment of the unit immediately, taking care to avoid letting the battery fluid come into direct contact with your skin.)

**IMPORTANT**

Avoid continuous high volume setting when using headphones! Your normal hearing ability may otherwise be seriously affected!

2

3

4

**CASSETTE TAPE OPERATION  
PLAYBACK**

- 1.Plug the headphones to the PHONES jack.
- 2.Adjust the VOLUME control to the lowest position.
- 3.Open the cassette compartment.
- 4.Insert a pre-recorded cassette tape into the cassette compartment so that the open edge faces up.
- 5.Press the PLAY button.
- 6.Adjust the VOLUME control to your comfortable listening level.
- 7.To stop the tape, press the STOP button.

**FAST FORWARD**

- 1.To fast wind a tape, push the F.FWD button.
- 2.When the desired location has been reached push the STOP button.

**SPECIFICATION**

DC: 3V, 2 xAA (R6P) batteries  
 AC: with AC adapter (1.3∅ plug, center pin negative, DC 3V)  
 Frequency response: 60-10,000 Hz(Normal tape)  
 Dimensions: 111 x 84 x 31 (WHD)  
 Weight: 136g (with out batteries)

FOR ADDITIONAL SET UP OR OPERATING ASSISTANCE, PLEASE CONTACT CUSTOMER SERVICE AT (954) 660-7100 PLEASE KEEP ALL PACKAGING MATERIAL FOR AT LEAST 90 DAYS IN CASE YOU NEED TO RETURN THIS PRODUCT TO PLACE OR PURCHASE. FOR PARTS AND ACCESSORIES, CONTACT FOX INTERNATIONAL AT 1-800-321-6993



SUBJECT TO MODIFICATION WITHOUT NOTICE!

5

6

7

## Free Manuals Download Website

<http://myh66.com>

<http://usermanuals.us>

<http://www.somanuals.com>

<http://www.4manuals.cc>

<http://www.manual-lib.com>

<http://www.404manual.com>

<http://www.luxmanual.com>

<http://aubethermostatmanual.com>

Golf course search by state

<http://golfingnear.com>

Email search by domain

<http://emailbydomain.com>

Auto manuals search

<http://auto.somanuals.com>

TV manuals search

<http://tv.somanuals.com>