



INSTALLATION INSTRUCTIONS FOR PART 95-7418

APPLICATIONS **2002-2004 Nissan Altima**

95-7418



KIT FEATURES

- DDIN Head Unit Provision
- STACKED ISO DIN Head Unit Provision

KIT COMPONENTS

A) Trim Plate

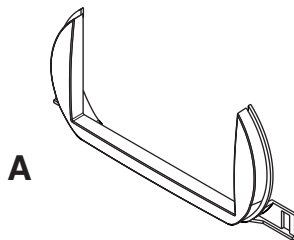

TOOLS REQUIRED:

Flat Blade Screwdriver | Phillips Screwdriver

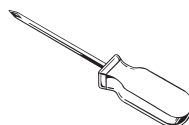
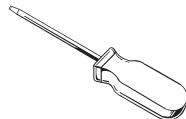

1-800-221-0932



www.metraonline.com

© COPYRIGHT 2004 METRA ELECTRONICS CORPORATION



TABLE OF CONTENTS

Dash Disassembly 1

Kit Assembly 2-3

Final Assembly 4

2002-2004 NISSAN ALTIMA

- 1 Disconnect the negative battery terminal to prevent an accidental short circuit.
- 2 Unclip and remove the trim panel surrounding the climate controls. (Figure A)
- 3 Remove (1) Phillips screw (bottom right side of panel) securing the panel surrounding the radio then unclip and remove the panel. (Figure B,C)
- 4 Remove (4) Phillips screws securing radio to remove. (Figure D)
- 5 Remove the screws securing the factory brackets to the radio and remove brackets. (Retain brackets for re-use during kit assembly.)

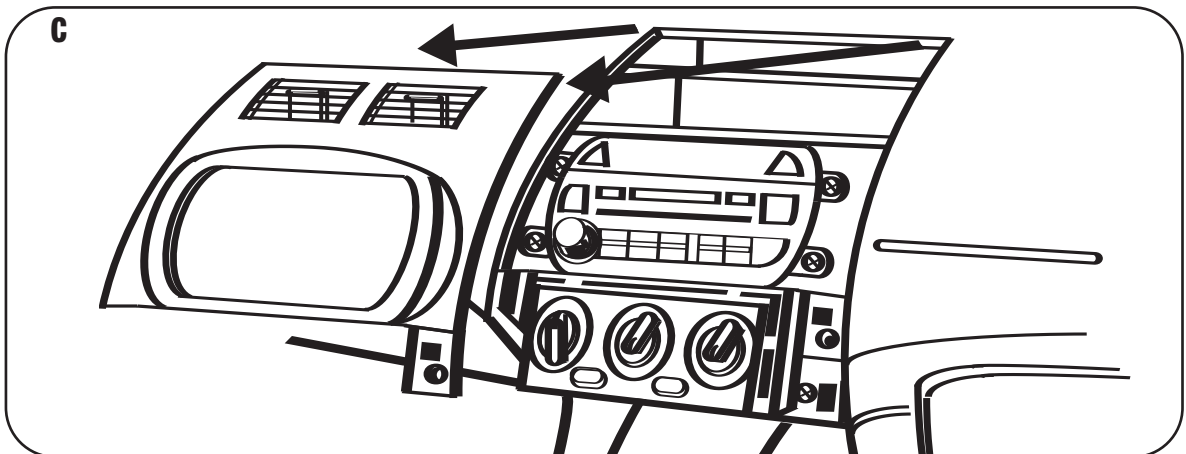
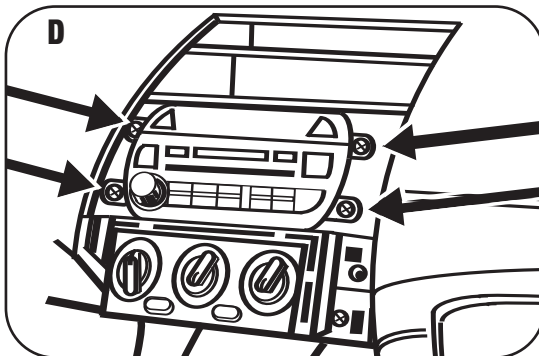
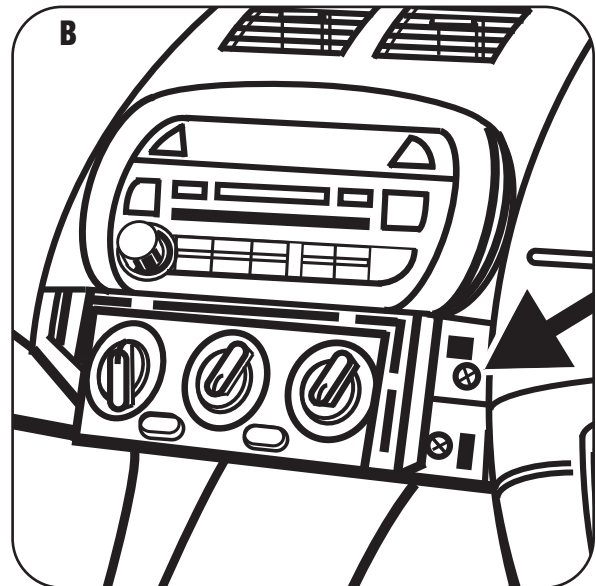
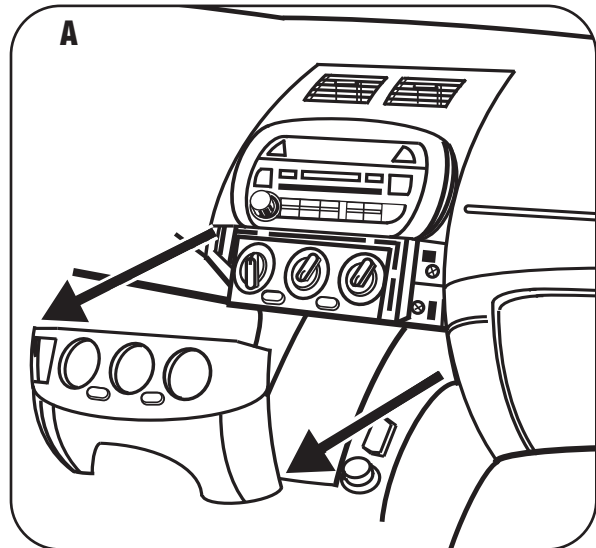

DOUBLE DIN HEAD UNIT PROVISION

- 1 Snap the 95-7418 trim plate into the radio trim panel. (Figure A)

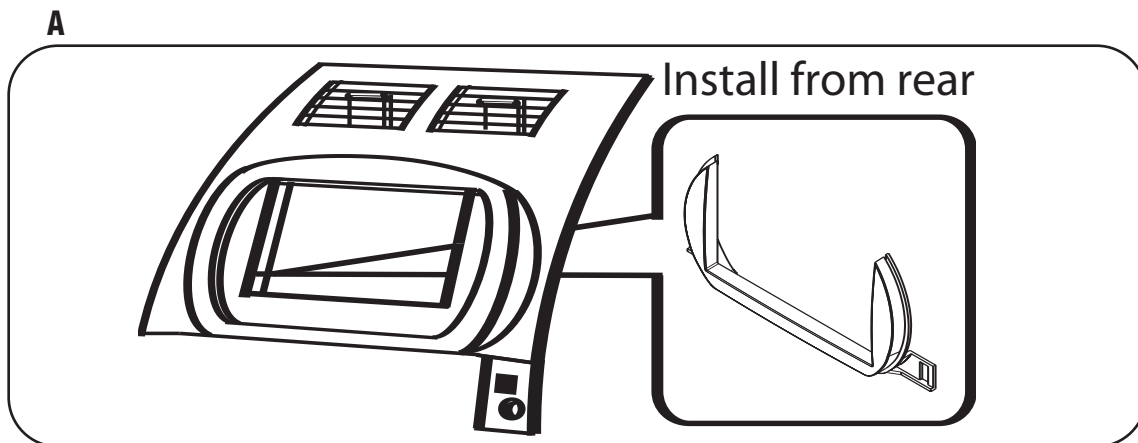

- 2 Slide the DDIN radio unit into the factory brackets and secure the unit to the brackets using the screws supplied with the head unit. (Figure B)

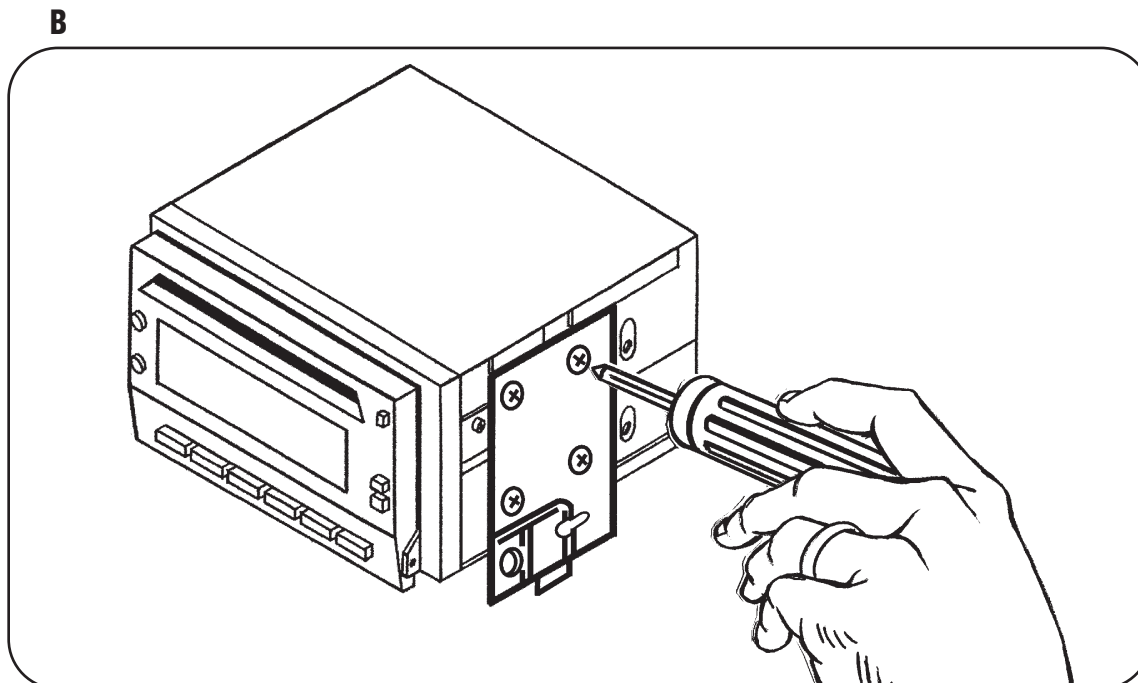

STACKED ISO DIN HEAD UNIT PROVISION

- 1 Snap the 95-7418 trim plate into the radio trim panel. (Figure A)

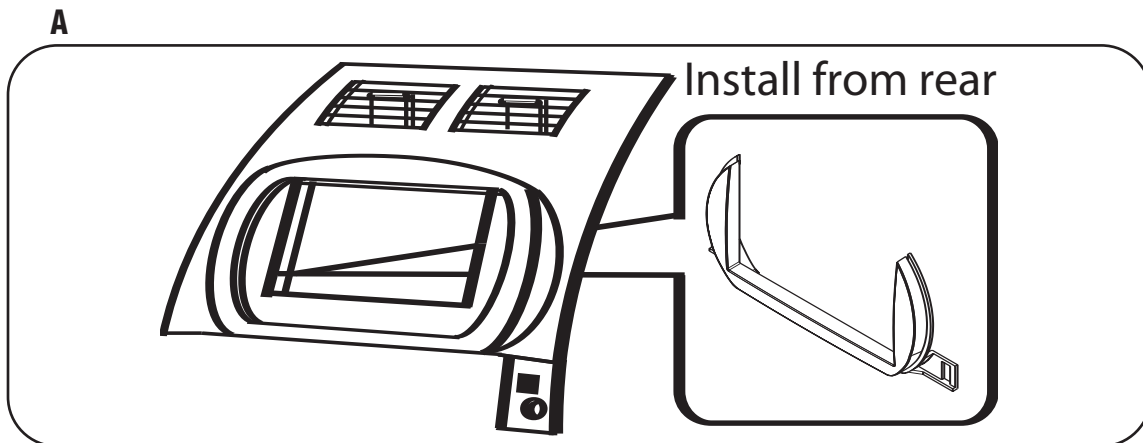

- 2 Slide the stacked ISO DIN units into the factory brackets and secure the units to the brackets using the screws supplied with the head unit. (Figure B)

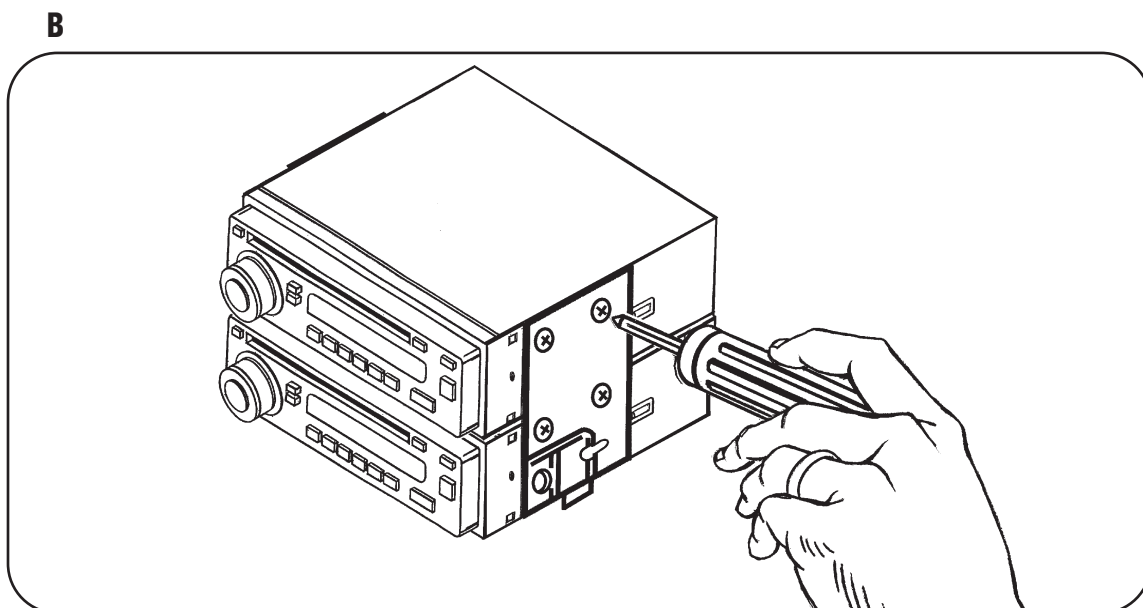

FINAL ASSEMBLY

- 1 Locate the factory wiring harness in the dash and make the connection as shown. Metra recommends using the proper mating adapter and making the connections as shown. (Isolate and individually tape off the ends of any unused wires to prevent electrical short circuit.)
- 2 Re-connect the negative battery terminal and test the unit for proper operation.
- 3 Reassemble radio and dash assemblies in reverse order of disassembly.

FINAL WIRING CONNECTIONS

Make wiring connections using the EIA color code chart shown below and the instructions included with the head unit. Metra recommends making connections as shown below; Strip, Splice, Solder, Tape. Isolate and individually tape off ends of any unused wires to prevent electrical short circuit.

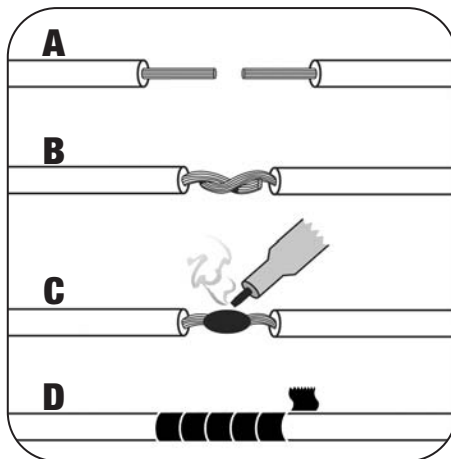

- A) Strip wire ends back 1/2"**
- B) Twist ends together**
- C) Solder**
- D) Tape**

METRA / EIA WIRING CODE

12V Ignition / Acc . . . Red	Right Front (+) Gray
12V Batt / Memory . . Yellow	Right Front (-) Gray / Black
Ground Black*	Left Front (+) White
Power Antenna Blue	Left Front (-) White / Black
Amp Turn-On Blue / White	Right Rear (+) Violet
Amp Ground Black / White	Right Rear (-) Violet / Black
Illumination Orange	Left Rear (+) Green
Dimmer Orange / White	Left Rear (-) Green / Black

***NOTE:** When Black a wire is not present, ground radio to vehicle chassis.
All colors may not be present on all leads due to manufacturer's specifications.

95-7418 INSTRUCTIONS



1-800-221-0932



www.metraonline.com

REV. 09/06/07

© COPYRIGHT 2004 METRA ELECTRONICS CORPORATION

INST95-7418

Free Manuals Download Website

<http://myh66.com>

<http://usermanuals.us>

<http://www.somanuals.com>

<http://www.4manuals.cc>

<http://www.manual-lib.com>

<http://www.404manual.com>

<http://www.luxmanual.com>

<http://aubethermostatmanual.com>

Golf course search by state

<http://golfingnear.com>

Email search by domain

<http://emailbydomain.com>

Auto manuals search

<http://auto.somanuals.com>

TV manuals search

<http://tv.somanuals.com>