



## INSTALLATION INSTRUCTIONS FOR PART 99-5816

### APPLICATIONS FORD Focus 2008-2011

# 99-5816

#### KIT FEATURES

- DIN Radio Provision with Pocket
- ISO Mount Radio Provision with Pocket
- Double DIN Radio Provision
- Stacked ISO Mount Units Provision
- Painted To Match Factory Dash



#### KIT COMPONENTS

- A) Radio Housing • B) ISO Brackets • C) ISO Trim Plate • D) Double DIN Brackets
- E) Double DIN Trim Plate • F) Pocket • G) (2) Top Clips and (4) Middle Radio Housing Clips

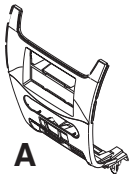

A

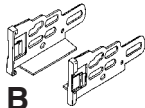

B

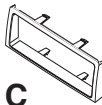

C



D

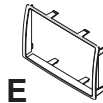

E

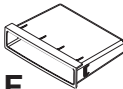

F

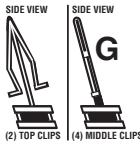

(2) TOP CLIPS (4) MIDDLE CLIPS

#### Wiring & Antenna Connections (sold separately)

XSVI-5520-NAV - Ford Interface

AFSI-02 - if equipped w/ sync

70-5522 - Ford Sub Harness

#### TOOLS REQUIRED:

- Small Flat Blade Screwdriver/ Panel Removal Tool
- Phillips Screwdriver • Socket Set • Cutting Tool



1-800-221-0932



www.metraonline.com

© COPYRIGHT 2004-2008 METRA ELECTRONICS CORPORATION



**TABLE OF CONTENTS**

**Dash Disassembly**

**- Ford Focus 2008-2011 ..... 1,2**

**Kit Assembly**

**- Kit Preparation ..... 3**  
**- DIN Mount Radio Provision with Pocket ..... 4**  
**- ISO Mount Radio Provision with Pocket ..... 5**  
**- Double DIN /Stacked ISO Mount Units Radio Provision ..... 6**

**Final Assembly ..... 7**

**Note:**

**Refer also to the instructions included with the aftermarket radio.**



**KNOWLEDGE IS POWER**

Enhance your installation and fabrication skills by enrolling in the most recognized and respected mobile electronics school in our industry. Log onto [www.installerinstitute.com](http://www.installerinstitute.com) or call 800-354-6782 for more information and take steps toward a better tomorrow.

## FORD FOCUS 2008-2011

- 1 Disconnect the negative battery terminal to prevent an accidental short circuit.
- 2 Unclip and remove the trim panel surrounding the shifter and including the cup holders. (Figure A)
- 3 Remove (2) 9/32" screws from the bottom edge of the factory radio trim panel. (Figure B)
- 4 Remove (2) 9/32" screws facing up above the gauge cluster then unclip and remove the trim panel surrounding the gauge cluster. (Figure C)
- 5 Unclip and remove the trim panel above the glove box. (Figure D)

Continue on page 2.

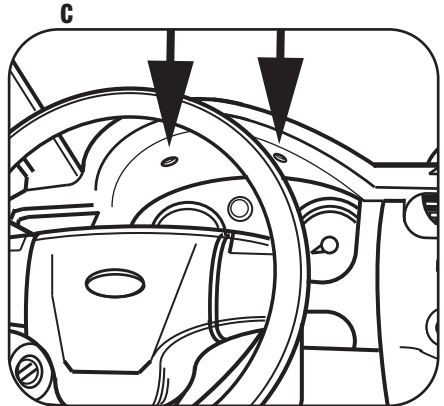
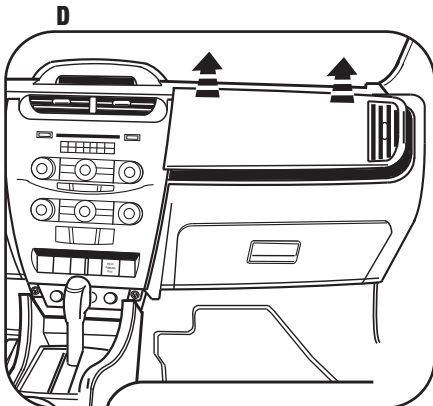
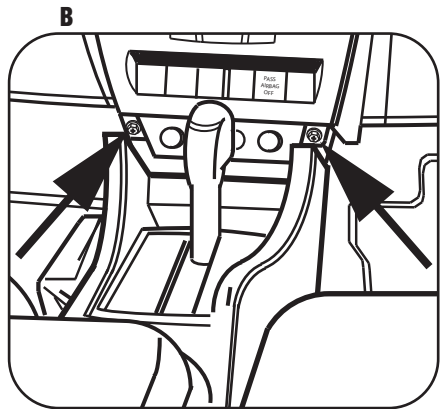
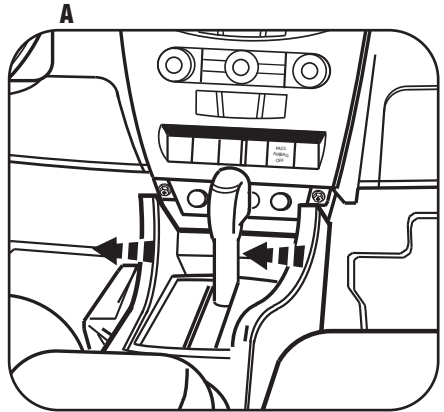

## FORD FOCUS 2008-2011

**6** Unclip and remove the vent panel at the top of the factory radio trim panel. (Figure E)

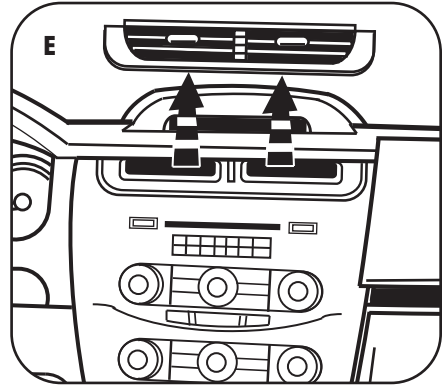

**7** Remove (2) 9/32" screws behind the vent panel removed in step 6. (Figure F)

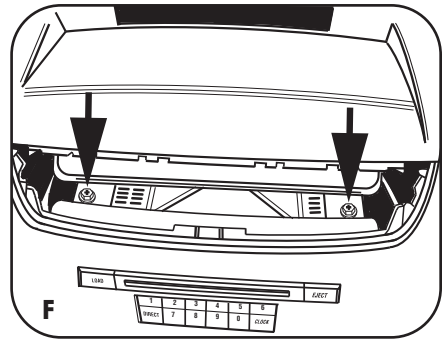

**8** Unclip the factory radio trim panel assembly. Unplug and remove the assembly. **Note:** Some early models had a ground strap attached to the radio chassis and the sub dash with an 8 MM bolt. You will need to unbolt this strap to remove the factory radio trim panel assembly.

**9** Remove (4) T-20 Torx screws securing the climate controls to the factory radio trim panel assembly and remove the controls from the assembly. (Retain the screws and climate controls for re-use during kit preparation.) (Figure G)

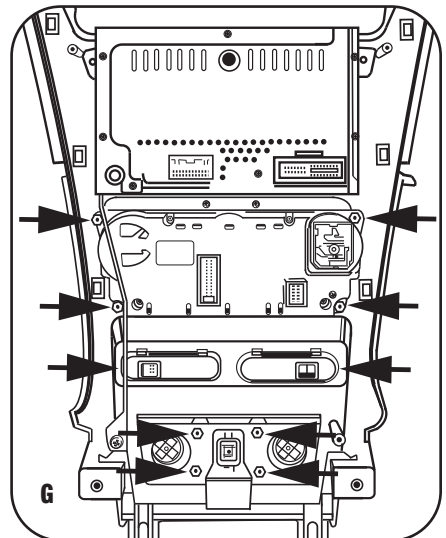

**10** Remove (4) T-20 Torx screws securing the accessory socket panel to the factory radio trim panel assembly and remove the socket panel from the assembly. (Retain the screws and accessory socket panel for re-use during kit preparation.) (Figure G)

**11** Unclip and remove the passenger air bag light and the switch panel blank plates. (Retain the air bag light and blank plates for re-use during kit preparation.) (Figure G)

*Continue to kit preparation.*

## KIT PREPARATION

- 1 Secure the climate control into the radio housing using the factory hardware. (Figure A)
- 2 Secure the accessory socket panel to the radio housing using the factory hardware. (Figure B)
- 3 Clip the passenger air bag light and the switch panel blank plates in to the radio housing. (Figure C)
- 4 Attach Top and Middle Radio Housing Clips to the back of the radio housing. (Figure D,E)

**NOTE:** When the clips are properly attached they should be on a 90 degree angle with the radio housing.

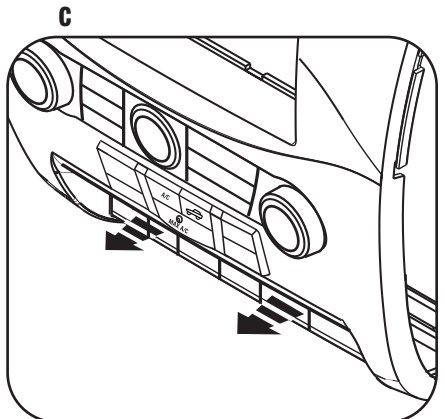
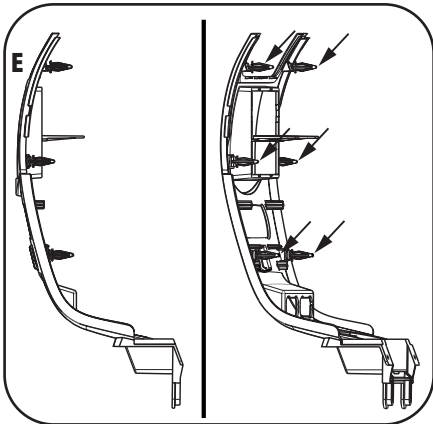
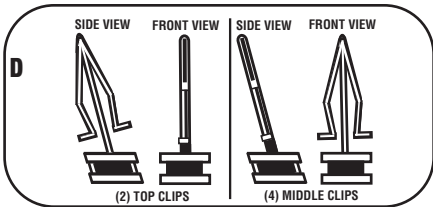
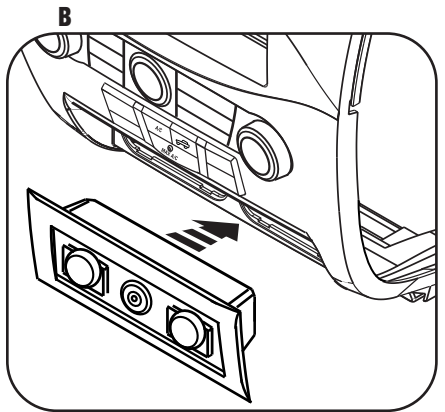
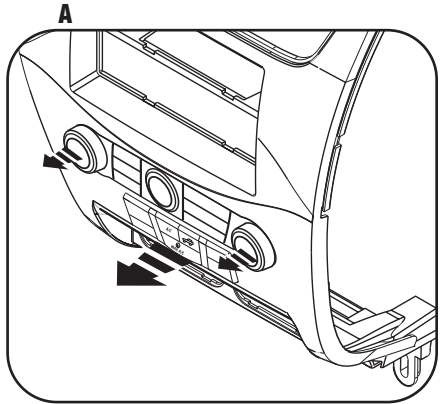

## DIN MOUNT RADIO PROVISION WITH POCKET

*\*Note: Refer also to the instructions included with the aftermarket radio.*

- 1 Slide the DIN cage into the radio housing and secure by bending the metal locking tabs outward. (Figure A)
- 2 Slide the aftermarket radio into the DIN cage and until it snaps into place.
- 3 Snap the pocket into the radio housing. (Figure C)

*Continue to final assembly.*

**A**

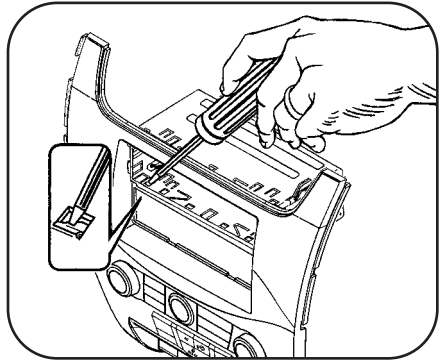

**B**

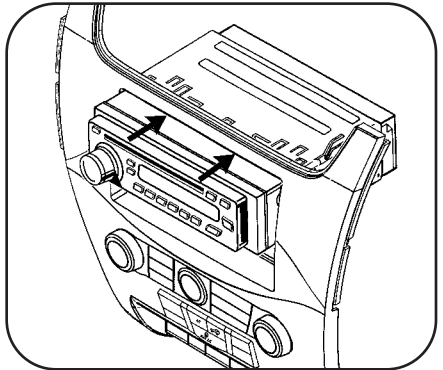

**C**

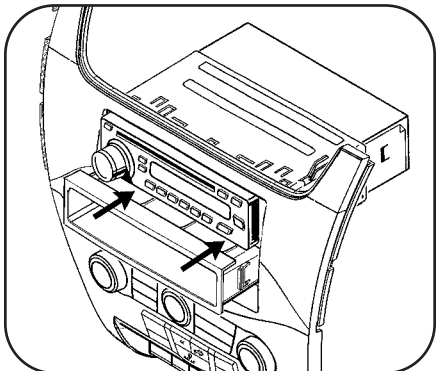

## ISO MOUNT RADIO PROVISION WITH POCKET

*\*Note: Refer also to the instructions included with the aftermarket radio.*

- 1 Mount the ISO Brackets to the radio using the screws supplied with the radio. (Figure A)
- 2 Slide the radio into the radio housing until it snaps into place. (Figure B)
- 3 Snap the trim plate onto the front of the Radio Housing. (Figure B)
- 4 Snap the Pocket into the radio housing. (Figure C)

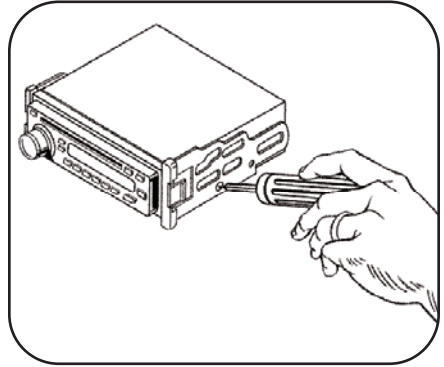

*Continue to final assembly.*

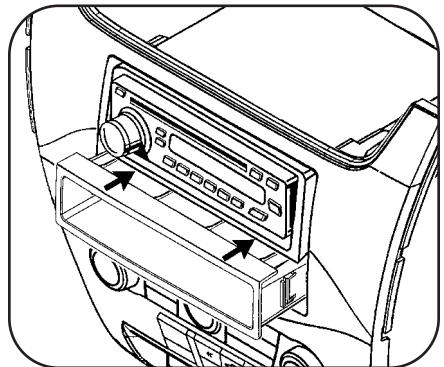
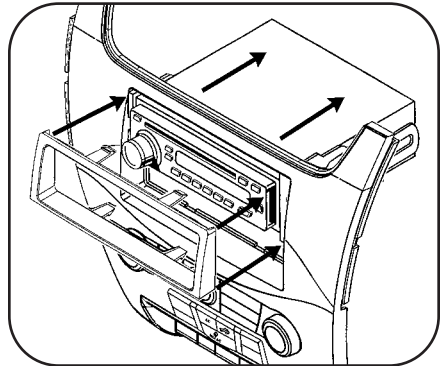

## DOUBLE DIN/STACKED ISO MOUNT UNITS RADIO PROVISION

*\*Note: Refer also to the instructions included with the aftermarket radio.*

- 1 Cut and remove the center bar from the radio housing. (Figure A)
- 2 Snap the Double DIN brackets to the inside edge of the radio housing. (Figure B)
- 3 Slide the Double DIN or stacked ISO mount unit(s) into the bracket/radio housing assembly and secure the unit(s) to the assembly using the screws supplied with the unit(s). (Figure C)
- 4 Snap the double DIN trim plate onto the front of the radio housing. (Figure C)

*Continue to final assembly.*

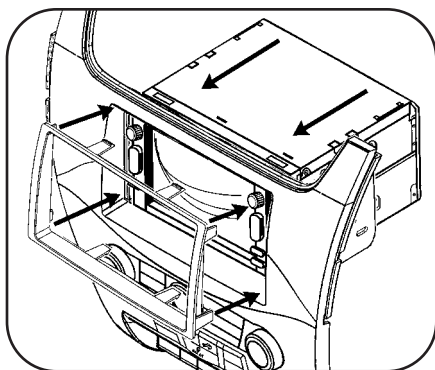
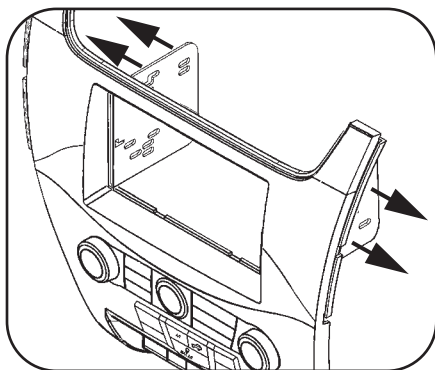
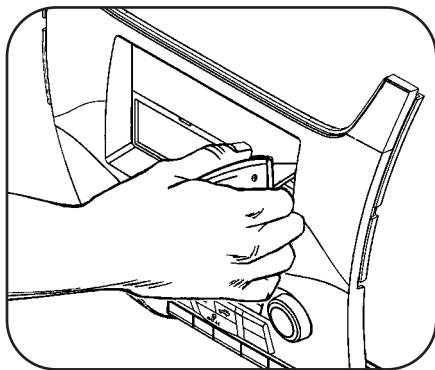



# FINAL ASSEMBLY

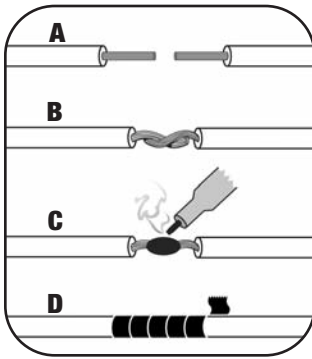

**(A) Strip wire ends back 1/2"**

**B) Twist ends together**

**C) Solder**

**D) Tape**

- 1 Locate the factory wiring harness in the dash. Metra recommends using the proper mating adapter and making connections as shown. (Isolate and individually tape off the ends of any unused wires to prevent electrical short circuit.)
- 2 Re-connect the negative battery terminal and test the unit for proper operation.
- 3 Reassemble radio and dash assemblies in reverse order of disassembly.

## FINAL WIRING CONNECTIONS

Make wiring connections using the EIA color code chart shown below and the instructions included with the head unit. Metra recommends making connections as shown below; Strip, Splice, Solder, Tape. Isolate and individually tape off ends of any unused wires to prevent electrical short circuit.

### METRA / EIA WIRING CODE

12V Ignition / Acc. . . . .	Red	Right Front (+) . . . . .	Gray
12V Batt / Memory . . . . .	Yellow	Right Front (-) . . . . .	Gray/ Black
Ground . . . . .	Black*	Left Front (+) . . . . .	White
Power Antenna . . . . .	Blue	Left Front (-) . . . . .	White / Black
Amp Turn-On . . . . .	Blue / White	Right Rear (+) . . . . .	Violet
Amp Ground . . . . .	Black / White	Right Rear (-) . . . . .	Violet / Black
Illumination . . . . .	Orange	Left Rear (+) . . . . .	Green
Dimmer . . . . .	Orange / White	Left Rear (-) . . . . .	Green / Black

**\*NOTE:** When a Black wire is not present, ground radio to vehicle chassis.  
All colors may not be present on all leads due to manufacturer's specifications.





# 99-5816 INSTRUCTIONS



**1-800-221-0932**



**[www.metraonline.com](http://www.metraonline.com)**

REV. 11/18/10 © COPYRIGHT 2004-2010 METRA ELECTRONICS CORPORATION INST99-5816

## Free Manuals Download Website

<http://myh66.com>

<http://usermanuals.us>

<http://www.somanuals.com>

<http://www.4manuals.cc>

<http://www.manual-lib.com>

<http://www.404manual.com>

<http://www.luxmanual.com>

<http://aubethermostatmanual.com>

Golf course search by state

<http://golfingnear.com>

Email search by domain

<http://emailbydomain.com>

Auto manuals search

<http://auto.somanuals.com>

TV manuals search

<http://tv.somanuals.com>