



Metra Division of METRACORP

99-7001 CK-612MI INSTALLATION INSTRUCTIONS

APPLICATIONS

CAR

DODGE

Colt 1993-95.....	1
Stealth 1991-96.....	2

EAGLE

Summit 1993-95.....	1
Summit (wg) 1992-96.....	3
Talon 1990-94.....	4
Talon 1995-98.....	5

MITSUBISHI

3000GT 1991-98.....	2
Diamante 1994-96.....	6
Eclipse 1989-94.....	4
Eclipse 1995-98.....	5
Eclipse 2000-01.....	7
Expo 1992-95.....	3
Galant 1994-98.....	8
Mirage 1993-96.....	1
Mirage 1997-00.....	9
Montero 1992-96.....	10
Montero Sport 2000-02.....	11

PLYMOUTH

Colt Vista 1992-94.....	3
Laser 1990-94.....	4

KIT COMPONENTS

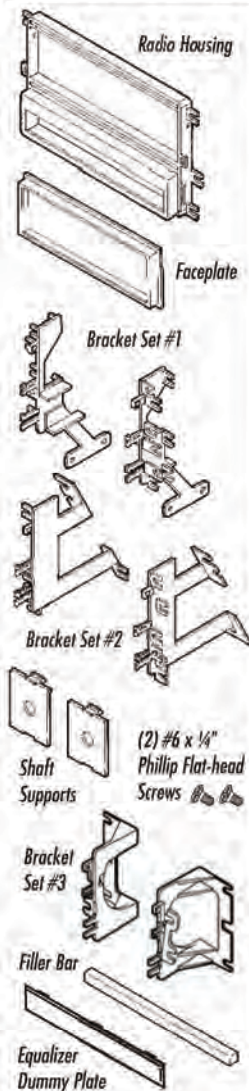

TOOLS REQUIRED



DODGE Colt / EAGLE Summit 1993-95 MITSUBISHI Mirage 1993-96

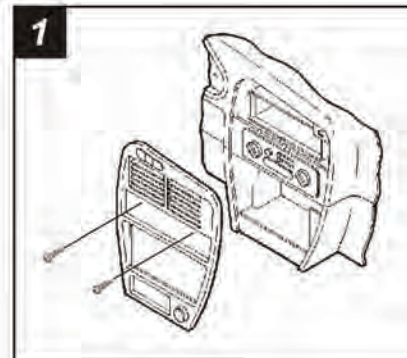

Disconnect the negative battery terminal to prevent an accidental short circuit. Remove (2) Phillips screws below the a/c vents. Pry out on the top of the dash trim bezel and remove the bezel. Remove (4) screws securing the factory head unit and disconnect the wiring.

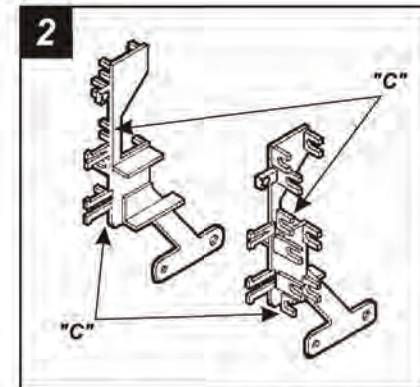

Cut and remove mounting tabs "A" and "B" on the **Radio Housing**. Cut and remove all mounting tabs on **Bracket Set #1** EXCEPT tabs "C". The mounting tabs can be identified by the stamped letter on the back of each tab.

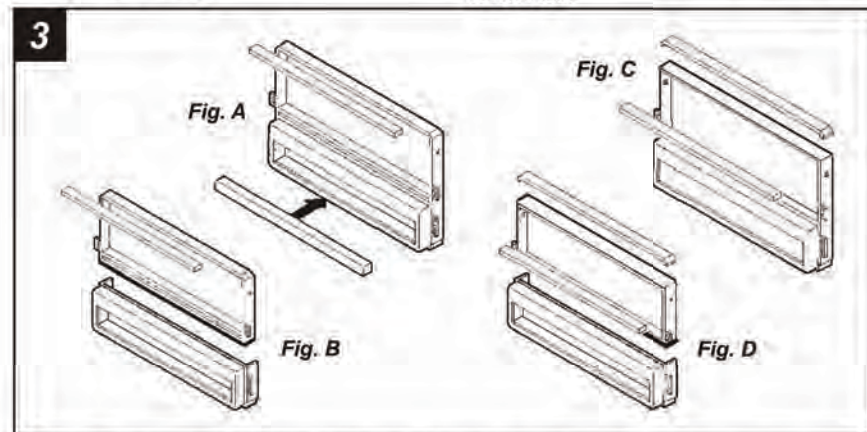

DASH TRIM BEZELS WITH A DIVIDED RADIO OPENING: If keeping the factory pocket is NOT desired, cut and remove the upper rib from the radio opening and snap the **Filler Bar** onto the bottom of the **Radio Housing**. (see Fig. A). If keeping the factory pocket is desired, cut and remove the upper rib from the radio opening and the bottom portion of the **Radio Housing**. (see Fig. B). Skip to the Installation Instructions for ALL VEHICLES on Page #12.

DASH TRIM BEZELS WITH AN UNDIVIDED RADIO OPENING: If keeping the factory pocket is NOT desired, cut and remove the lower rib from the radio opening and the top portion of the **Radio Housing**. (see Fig. C). If keeping the factory pocket is desired, cut and remove the lower rib from the radio opening, the top portion of the **Radio Housing** and the bottom portion of the **Housing**. (see Fig. D). Skip to the Installation Instructions for ALL VEHICLES on Page #12.

1-800-221-0932 www.metraonline.com

© COPYRIGHT 2001 METRA ELECTRONICS CORPORATION

DODGE Stealth 1991-96 / MITSUBISHI 3000GT 1991-98

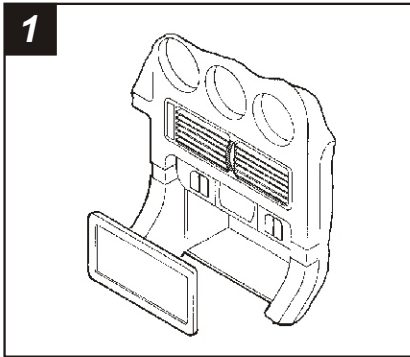

1
Disconnect the negative battery terminal to prevent an accidental short circuit. Using a panel removal tool, pry out on the radio trim bezel and remove. Remove (4) screws securing the factory head unit and disconnect the wiring.

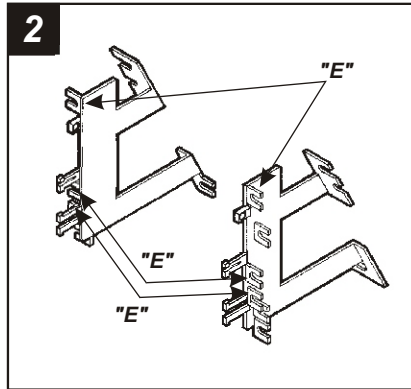

2
Cut and remove mounting tabs "A" and "B" on the **Radio Housing**. Cut and remove all mounting tabs on **Bracket Set #2** EXCEPT tabs "E". The mounting tabs can be identified by the stamped letter on the back of each tab.

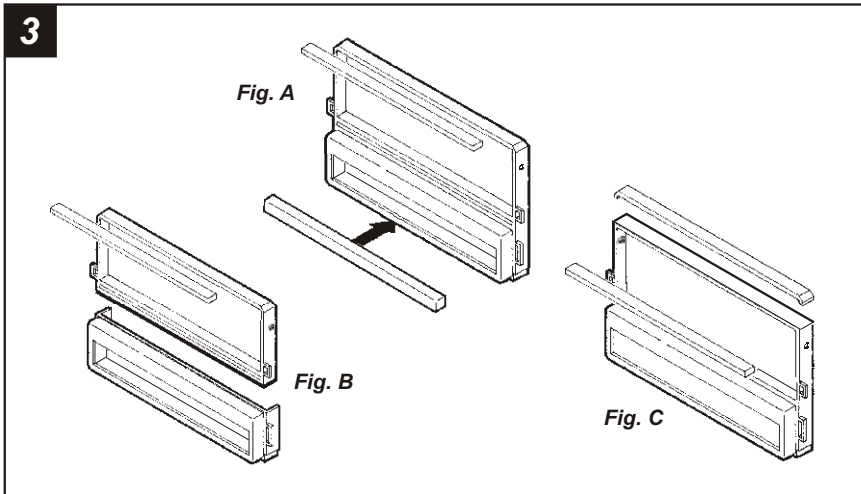

3
DASH TRIM BEZELS WITH A DIVIDED RADIO OPENING: If keeping the factory pocket is NOT desired, cut and remove the upper rib from the radio opening and snap the **Filler Bar** onto the bottom of the **Radio Housing**. (see Fig. A). If keeping the factory pocket is desired, cut and remove the upper rib from the radio opening and the bottom portion of the **Radio Housing**. (see Fig. B). Skip to the Installation Instructions for ALL VEHICLES on Page #12.

DASH TRIM BEZELS WITH AN UNDIVIDED RADIO OPENING: Cut and remove the lower rib from the radio opening and the top portion of the **Radio Housing**. (see Fig. C). Skip to the Installation Instructions for ALL VEHICLES on Page #12.

EAGLE Summit (wg) 1992-96 / MITSUBISHI Expo 1992-95 PLYMOUTH Colt Vista 1992-94

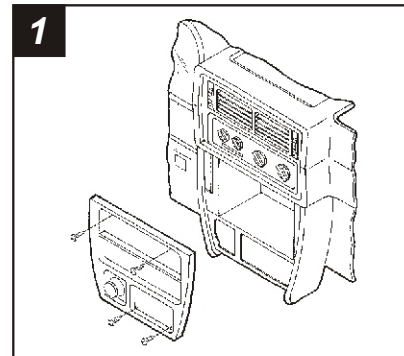

1
Disconnect the negative battery terminal to prevent an accidental short circuit. Remove (2) screws from the top edge of the dash trim bezel. Remove the ashtray and (2) screws exposed. Unclip the dash trim bezel and disconnect the cigarette lighter wiring. Remove (4) Phillips screws securing the factory head unit and disconnect the wiring.

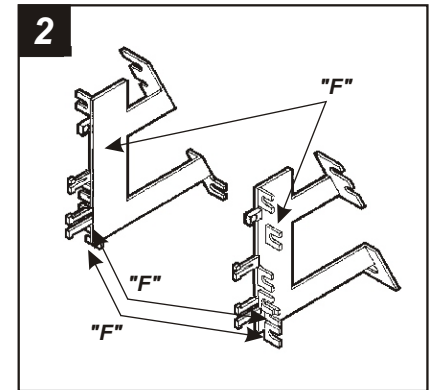

2
Cut and remove mounting tabs "A" and "B" on the **Radio Housing**. Cut and remove all mounting tabs on **Bracket Set #2** EXCEPT tabs "F". The mounting tabs can be identified by the stamped letter on the back of each tab.

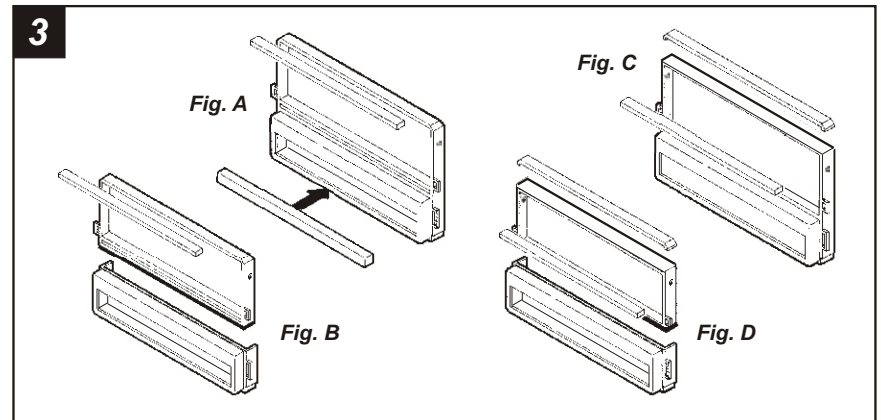

3
DASH TRIM BEZELS WITH A DIVIDED RADIO OPENING: If keeping the factory pocket is NOT desired, cut and remove the upper rib from the radio opening and snap the **Filler Bar** onto the bottom of the **Radio Housing**. (see Fig. A). If keeping the factory pocket is desired, cut and remove the upper rib from the radio opening and the bottom portion of the **Radio Housing**. (see Fig. B). Skip to the Installation Instructions for ALL VEHICLES on Page #12.

DASH TRIM BEZELS WITH AN UNDIVIDED RADIO OPENING: If keeping the factory pocket is NOT desired, cut and remove the lower rib from the radio opening and the top portion of the **Radio Housing**. (see Fig. C). If keeping the factory pocket is desired, cut and remove the lower rib from the radio opening, the top portion of the **Radio Housing** and the bottom portion of the Housing. (see Fig. D). Skip to the Installation Instructions for ALL VEHICLES on Page #12.

EAGLE Talon / MITSUBISHI Eclipse PLYMOUTH Laser 1990-94

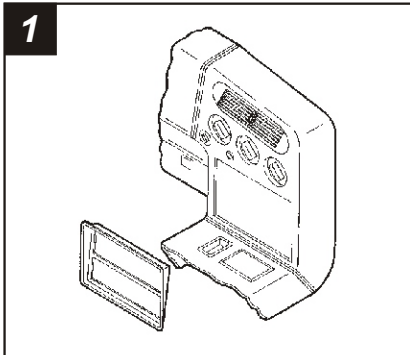

1
Disconnect the negative battery terminal to prevent an accidental short circuit. Unclip the radio trim bezel (the factory pocket will be attached). Remove (4) screws securing the factory head unit and disconnect the wiring.

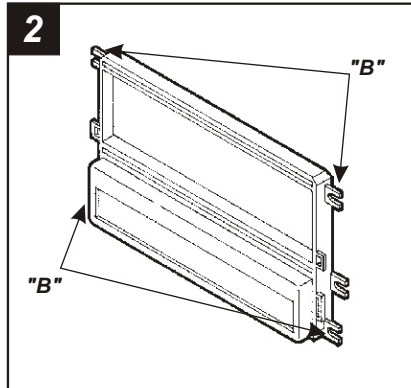

2
Cut and remove all mounting tabs on the **Radio Housing** EXCEPT tabs "B". The mounting tabs can be identified by the stamped letter on the back of each tab.

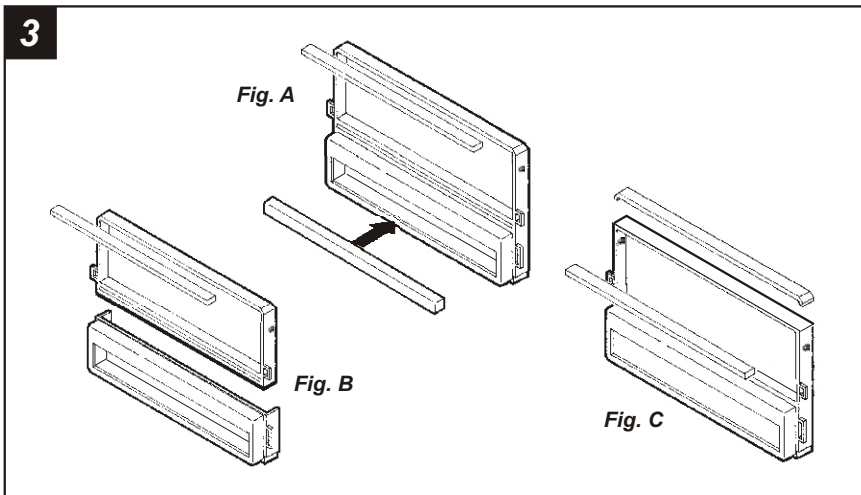

3
DASH TRIM BEZELS WITH A DIVIDED RADIO OPENING: If keeping the factory pocket is NOT desired, cut and remove the upper rib from the radio opening and snap the **Filler Bar** onto the bottom of the **Radio Housing**. (see Fig. A). If keeping the factory pocket is desired, cut and remove the upper rib from the radio opening and the bottom portion of the **Radio Housing**. (see Fig. B). Skip to the Installation Instructions for ALL VEHICLES on Page #12.

DASH TRIM BEZELS WITH AN UNDIVIDED RADIO OPENING: Cut and remove the lower rib from the radio opening and the top portion of the **Radio Housing**. (see Fig. C). Skip to the Installation Instructions for ALL VEHICLES on Page #12.

EAGLE Talon / MITSUBISHI Eclipse 1995-98

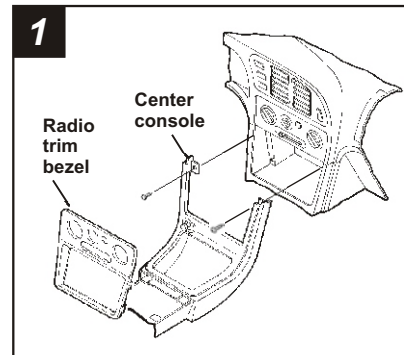

1
Disconnect the negative battery terminal to prevent an accidental short circuit. Slide the front seats forward and remove (1) cover cap and (1) Phillips screw from each side of the center console. Unsnap the cupholder/ashtray assembly and remove (2) Phillips screws exposed. Unclip the radio trim bezel and remove (2) Phillips screws exposed. Unscrew the shifter knob. Disconnect the cigarette lighter and light wiring. Lift up on the center console and remove. Remove (4) Phillips screws securing the factory head unit and disconnect the wiring.

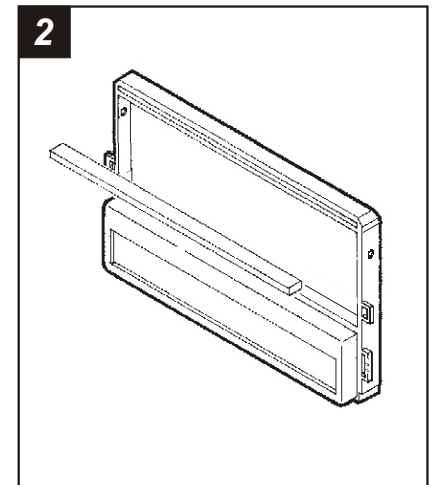

2
Cut and remove mounting tabs "A" and "B" on the **Radio Housing**. Cut and remove the lower rib from the radio opening.

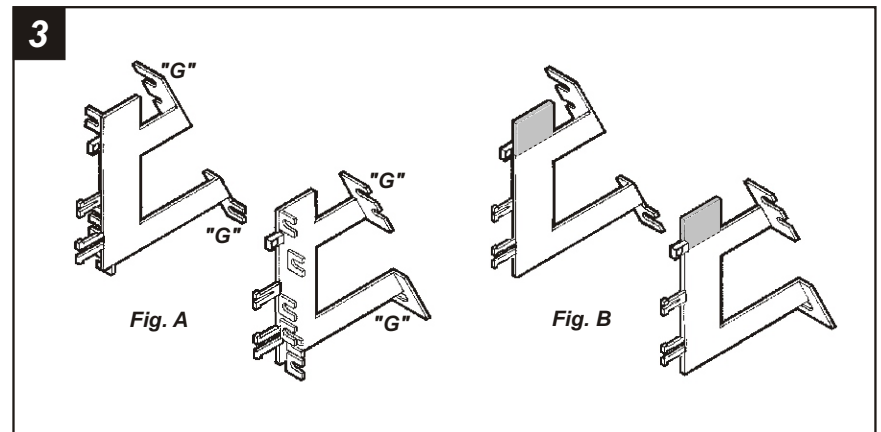

3
Cut and remove all mounting tabs on **Bracket Set #2** EXCEPT tabs "G". The mounting tabs can be identified by the stamped letter on the back of each tab. (see Fig. A). Once the mounting tabs are removed, cut and remove the SHADED portions of the Brackets. (see Fig. B). Skip to the Installation Instructions for ALL VEHICLES on Page #12.

MITSUBISHI Diamante 1994-96

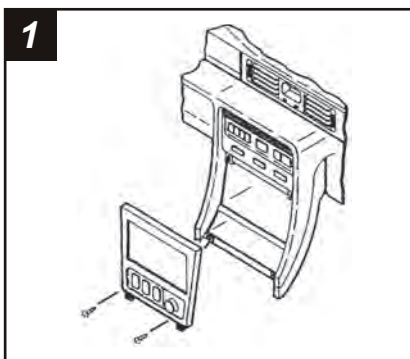

Disconnect the negative battery terminal to prevent an accidental short circuit. Remove (2) Phillips screws from each side of the gear shifter console. Remove (2) Phillips screws from the top of the console (under the ashtray). Lift the console out and remove (2) Phillips screws exposed at the base of the dash trim bezel. Pull out on the bottom of the dash trim bezel, disconnect the wiring and remove the bezel. Remove (4) screws securing the factory head unit and disconnect the wiring.

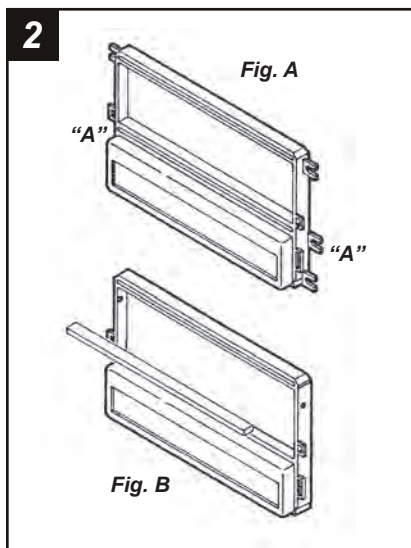

Cut and remove all mounting tabs on the **Radio Housing** EXCEPT tabs "A". The mounting tabs can be identified by the stamped letter on the back of each tab. (Fig. A). Cut and remove the lower rib from the radio opening. (Fig. B)

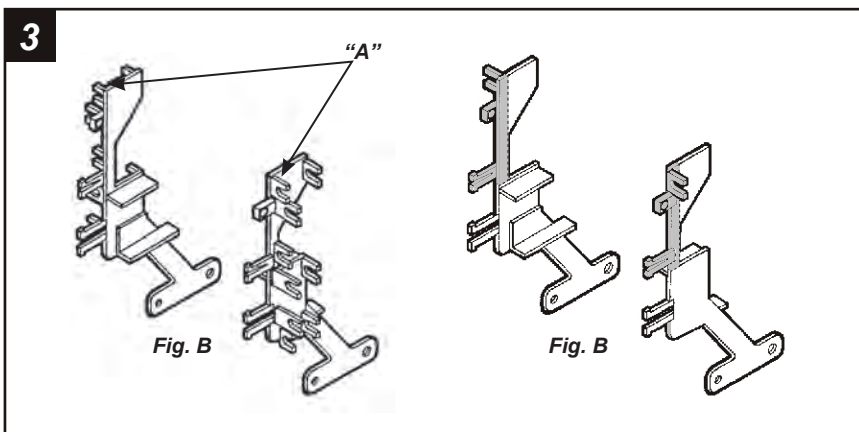

Cut and remove all mounting tabs on **Bracket Set #1** EXCEPT tabs "A". The mounting tabs can be identified by the stamped letter on the back of each tab. (see Fig. A). Once the mounting tabs are removed, cut the SHADED portions from the Brackets. (see Fig. B). (The SHADED portions of the Brackets will be mounted to the **Radio Housing** in step #4). Skip to the *Installation Instructions for ALL VEHICLES* on Page #12.

6

MITSUBISHI Eclipse 2000-01

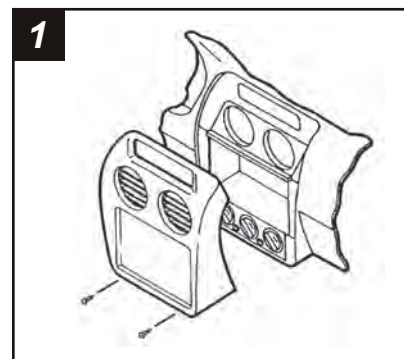

Disconnect the negative battery terminal to prevent an accidental short circuit. Remove (2) Phillips screws under the climate controls. Unclip the radio/climate control trim bezel and remove the bezel. Remove (4) Phillips screws securing the factory head unit and disconnect the wiring.

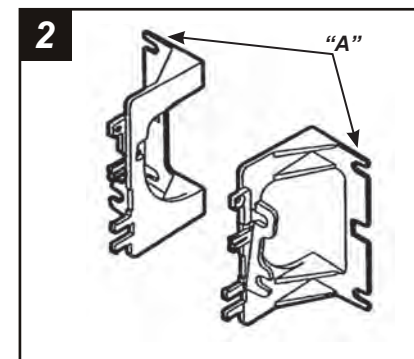

Cut and remove mounting tabs "A" and "B" on the **Radio Housing**. Locate mounting tabs "A" on **Bracket Set #3**. The mounting tabs can be identified by the stamped letter on the back of each tab.

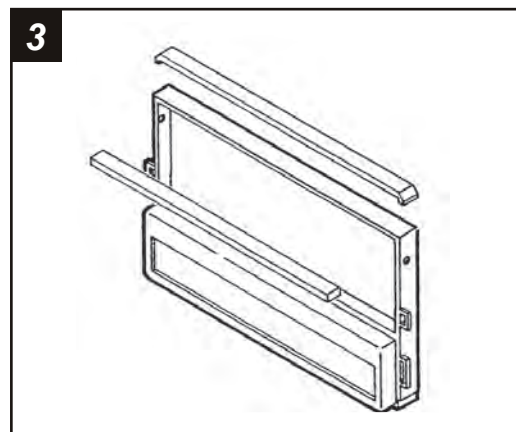

Cut and remove the lower rib from the radio opening and the top portion of the **Radio Housing**. Skip to step #5 on Page #13.

7

MITSUBISHI Galant 1994-98

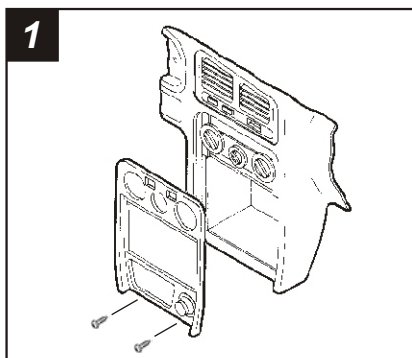

Disconnect the negative battery terminal to prevent an accidental short circuit. Unclip the gear shifter trim panel and remove. Remove (2) Phillips screws exposed at the base of the dash trim bezel. Unclip the dash trim bezel. Remove (4) Phillips screws securing the factory head unit and disconnect the wiring.

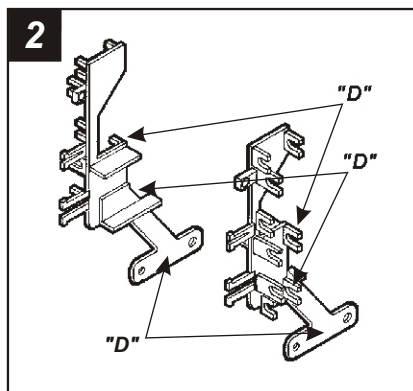

Cut and remove mounting tabs "A" and "B" on the **Radio Housing**. Cut and remove all mounting tabs on **Bracket Set #1** EXCEPT tabs "D". The mounting tabs can be identified by the stamped letter on the back of each tab.

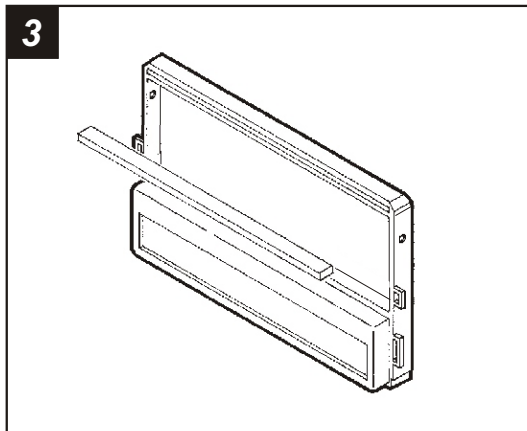

Cut and remove the lower rib from the radio opening. Skip to the Installation Instructions for ALL VEHICLES on Page #12.

MITSUBISHI Mirage 1997-00

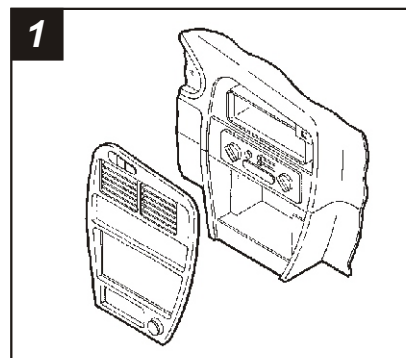

Disconnect the negative battery terminal to prevent an accidental short circuit. Pry out on the top of the dash trim bezel and remove the bezel. Remove (4) screws securing the factory head unit and disconnect the wiring.

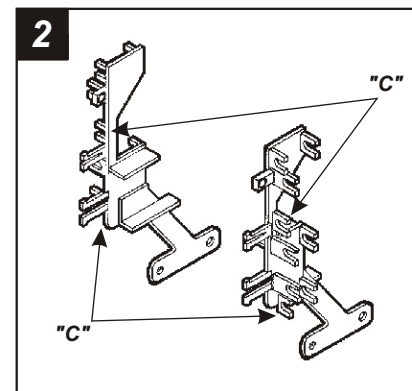

Cut and remove mounting tabs "A" and "B" on the **Radio Housing**. Locate mounting tabs "C" on **Bracket Set #1**. The mounting tabs can be identified by the stamped letter on the back of each tab.

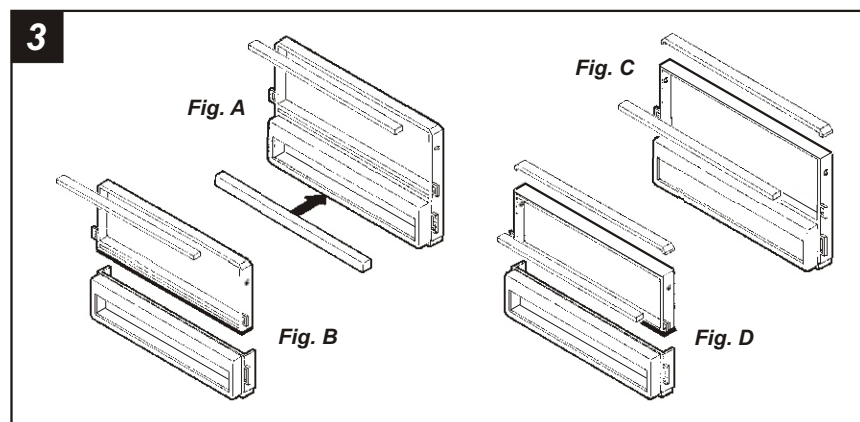

DASH TRIM BEZELS WITH A DIVIDED RADIO OPENING: If keeping the factory pocket is NOT desired, cut and remove the upper rib from the radio opening and snap the **Filler Bar** onto the bottom of the **Radio Housing**. (see Fig. A). If keeping the factory pocket is desired, cut and remove the upper rib from the radio opening and the bottom portion of the **Radio Housing**. (see Fig. B). Skip to the Installation Instructions for ALL VEHICLES on Page #12.

DASH TRIM BEZELS WITH AN UNDIVIDED RADIO OPENING: If keeping the factory pocket is NOT desired, cut and remove the lower rib from the radio opening and the top portion of the **Radio Housing**. (see Fig. C). If keeping the factory pocket is desired, cut and remove the lower rib from the radio opening, the top portion of the **Radio Housing** and the bottom portion of the Housing. (see Fig. D). Skip to the Installation Instructions for ALL VEHICLES on Page #12.

MITSUBISHI Montero 1992-96

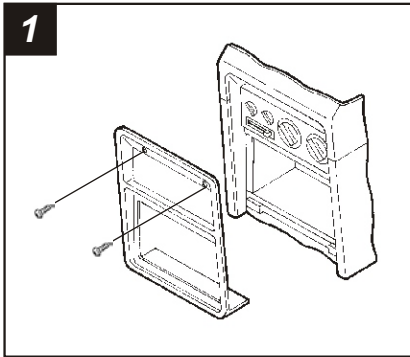

1
Disconnect the negative battery terminal to prevent an accidental short circuit. Remove (2) screws above the climate controls. Unclip the bottom of the dash trim bezel and remove the bezel. Remove (4) screws securing the factory head unit and disconnect the wiring.

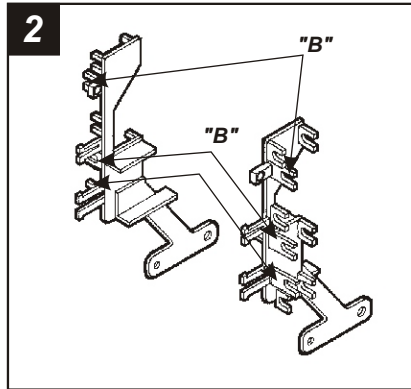

2
Cut and remove mounting tabs "A" and "B" on the **Radio Housing**. Cut and remove all mounting tabs on **Bracket Set #1** EXCEPT tabs "B". The mounting tabs can be identified by the stamped letter on the back of each tab.

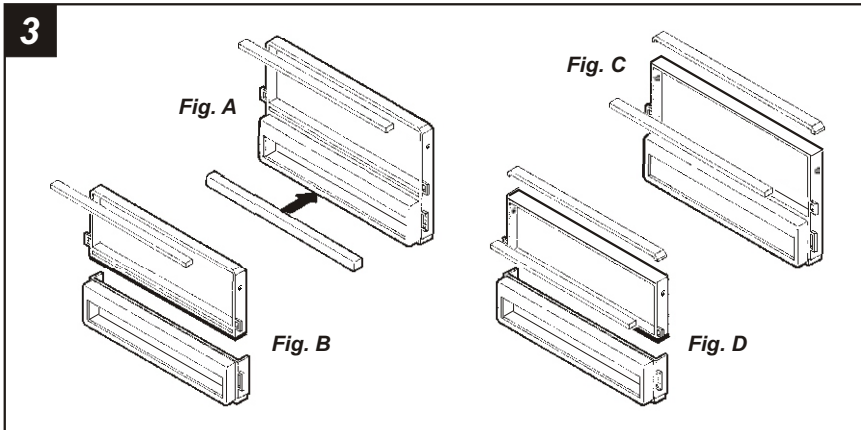

3
DASH TRIM BEZELS WITH A DIVIDED RADIO OPENING: If keeping the factory pocket is **NOT** desired, cut and remove the upper rib from the radio opening and snap the **Filler Bar** onto the bottom of the **Radio Housing**. (see Fig. A). If keeping the factory pocket is desired, cut and remove the upper rib from the radio opening and the bottom portion of the **Radio Housing**. (see Fig. B). Skip to the Installation Instructions for ALL VEHICLES on Page #12.

DASH TRIM BEZELS WITH AN UNDIVIDED RADIO OPENING: If keeping the factory pocket is **NOT** desired, cut and remove the lower rib from the radio opening and the top portion of the **Radio Housing**. (see Fig. C). If keeping the factory pocket is desired, cut and remove the lower rib from the radio opening, the top portion of the **Radio Housing** and the bottom portion of the Housing. (see Fig. D). Skip to the Installation Instructions for ALL VEHICLES on Page #12.

MITSUBISHI Montero Sport 2000-02

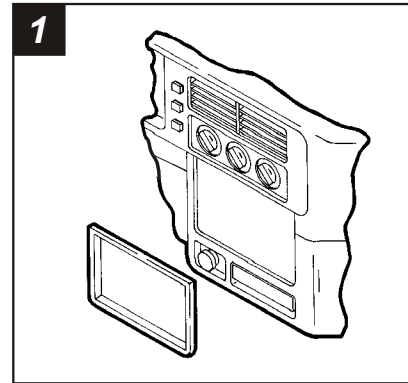

1
Disconnect the negative battery terminal to prevent an accidental short circuit. Unclip the radio/climate control trim bezel and remove the bezel. Remove (4) Phillips screws securing the factory head unit and disconnect the wiring.

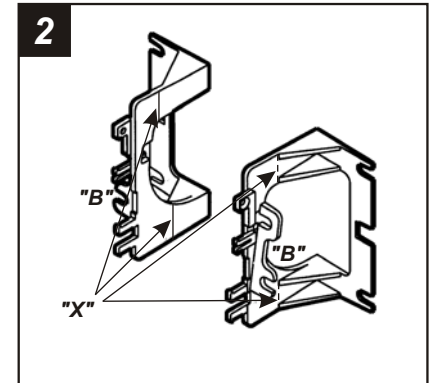

2
Cut and remove mounting tabs "A" and "B" on the **Radio Housing**. Locate mounting tabs "B" on **Bracket Set #3** and cut and remove the mounting legs containing tabs "A" by cutting along scored lines "X". The mounting tabs can be identified by the stamped letter on the back of each tab.

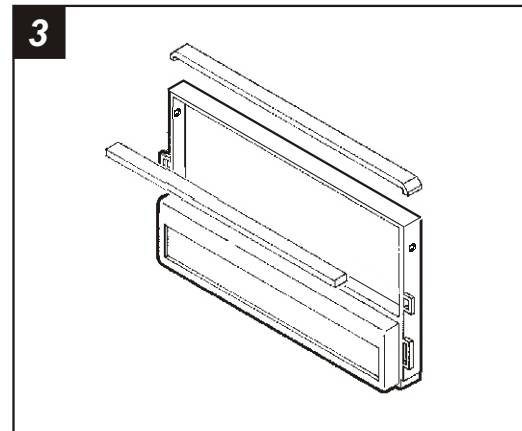

3
Cut and remove the lower rib from the radio opening and the top portion of the **Radio Housing**. Skip to step #5 on Page #13.

ALL VEHICLES

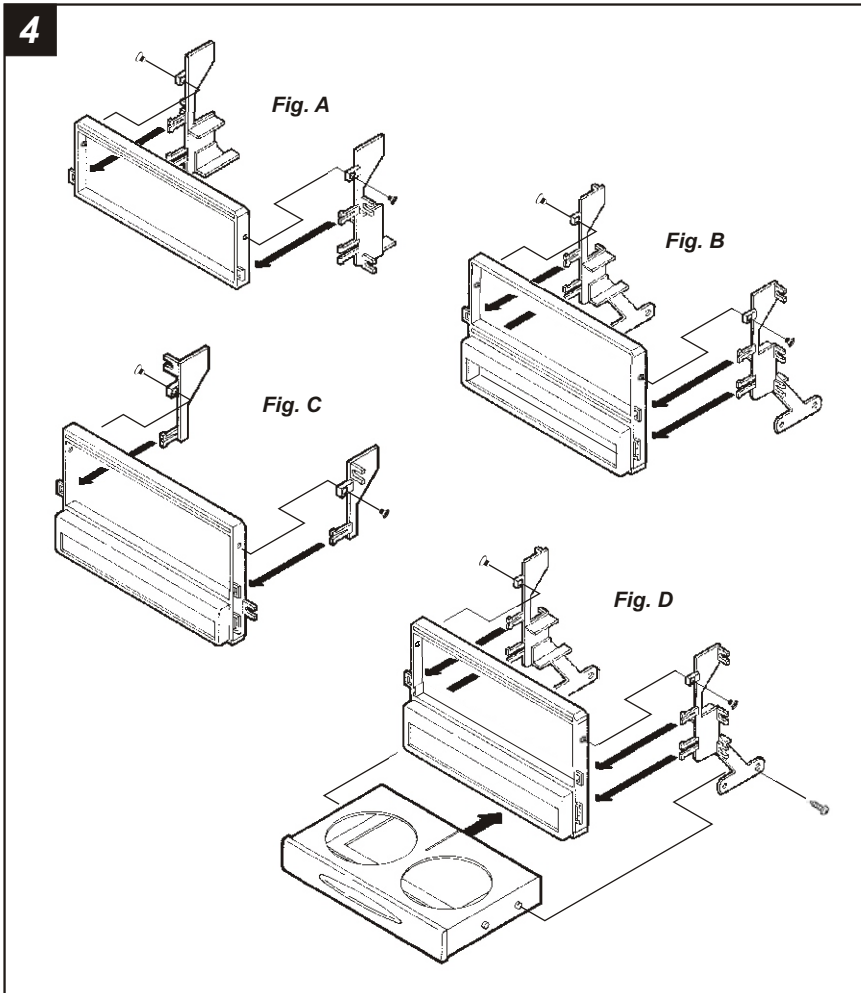

IF THE LOWER PORTION OF THE RADIO HOUSING HAS BEEN REMOVED FOR POCKET RETENTION: Mount the Brackets to the **Radio Housing** with (2) clips and (2) #6 x 1/4" Phillips Flat-head Screws supplied. (see Fig. A)

IF THE LOWER PORTION OF THE RADIO HOUSING HAS NOT BEEN REMOVED (EXCLUDING DIAMANTE and GALANT): Mount the Brackets to the **Radio Housing** with (4) clips and (2) #6 x 1/4" Phillips Flat-head Screws supplied. (see Fig. B)

DIAMANTE: Mount the Brackets to the **Radio Housing** with (2) clips and (2) #6 x 1/4" Phillips Flat-head Screws supplied. (see Fig. C)

GALANT: Mount the Brackets to the **Radio Housing** with (4) clips and (2) #6 x 1/4" Phillips Screws supplied. Slide the factory cupholder onto the mounted Brackets until the locator pins engage and mount with (2) screws previously removed. (see Fig. D)

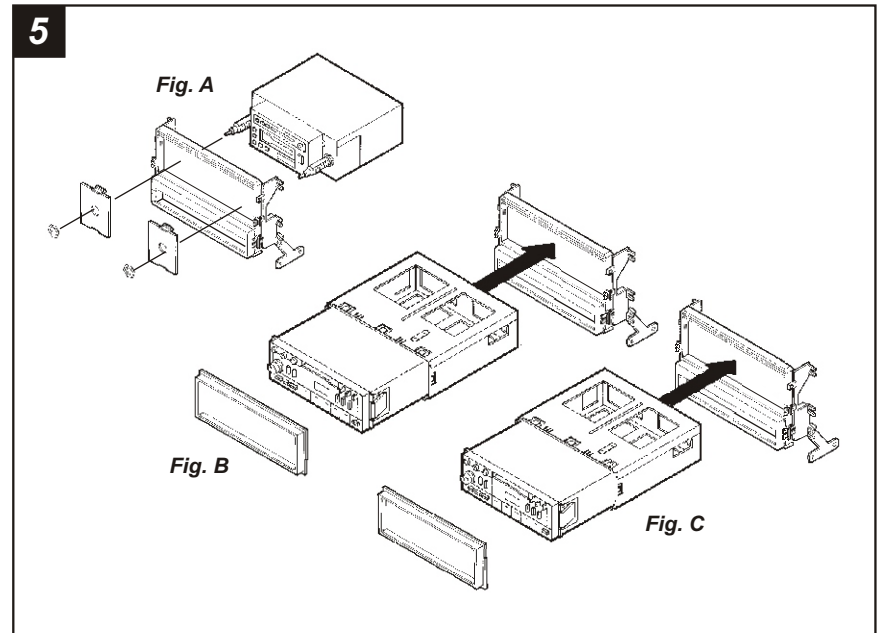

2-SHAFT HEAD UNITS: Snap the **Shaft Supports** into the **Radio Housing**. Slide the aftermarket head unit into the kit and secure with shaft nuts. (see Fig. A).

DIN HEAD UNITS: For dash trim bezels with an **UNDIVIDED** radio opening, slide the DIN cage into the **Radio Housing** and secure by bending the metal locking tabs down. Slide the aftermarket head unit into the cage until secure. With the side notches **DOWN**, snap the **Faceplate** onto the front of the Housing. (see Fig. B). For dash trim bezels with a **DIVIDED** radio opening, slide the DIN cage into the **Radio Housing** and secure by bending the metal locking tabs down. Slide the aftermarket head unit into the cage until secure. With the side notches **UP**, snap the **Faceplate** onto the front of the Housing. (see Fig. C)

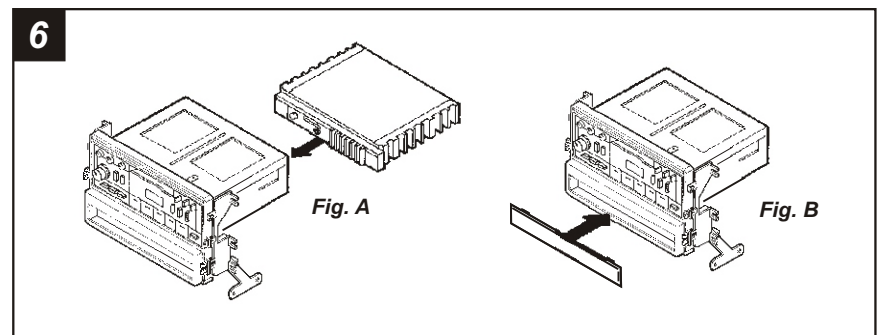

IF AN EQUALIZER WILL BE INCLUDED: Slide the aftermarket equalizer into the back of the **Radio Housing**. Using the hardware included with the equalizer, mount the unit to the kit. (see Fig. A)

IF AN EQUALIZER WILL NOT BE INCLUDED: Snap the **Equalizer Dummy Plate** into the **Radio Housing**. (see Fig. B)

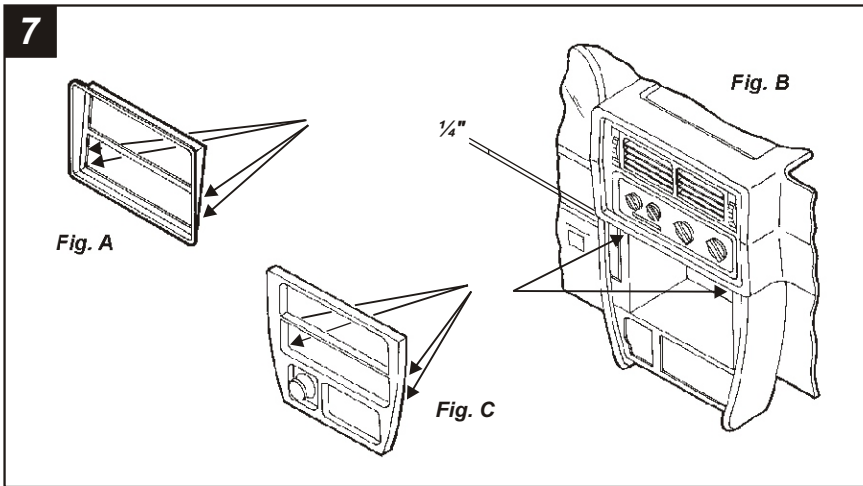

TALON 1995-98, ECLIPSE 1995-98, COLT, SUMMIT, MIRAGE, STEALTH, 3000GT, DIAMANTE, GALANT, MONTERO: No cutting of the dash or dash trim bezel is required. Skip to the Wiring Preparation in step #8.

TALON, ECLIPSE, LASER 1990-94: If keeping the factory pocket is desired, cut and remove the inside half of each pocket mount located on the back of the dash trim bezel. (see Fig. A)

SUMMIT (wagon), EXPO, COLT VISTA: Cut and remove 1/4" from the top edge of the dash cavity opening. (see Fig. B). If keeping the factory pocket is desired, cut and remove the pocket mounts located on the back of the dash trim bezel. (see Fig. C)

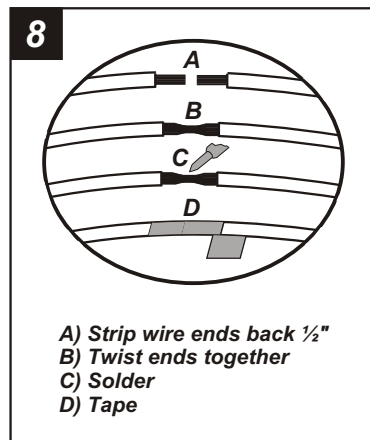

Locate the factory wiring harness in the dash. Metra recommends using the proper mating adaptor and making connections as shown. (Isolate and individually tape off the ends of any unused wires to prevent electrical short circuit).

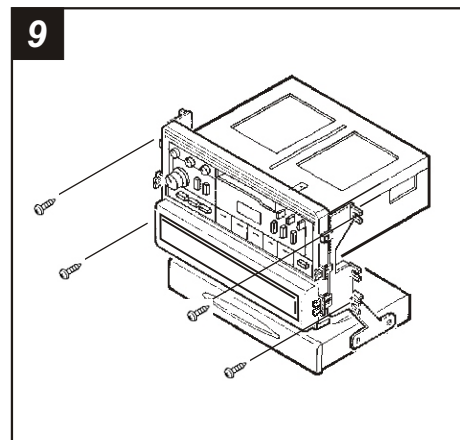

Re-connect the battery terminal and test the unit for proper operation. Mount the head unit/kit assembly to the sub-dash with those screws previously removed.

Free Manuals Download Website

<http://myh66.com>

<http://usermanuals.us>

<http://www.somanuals.com>

<http://www.4manuals.cc>

<http://www.manual-lib.com>

<http://www.404manual.com>

<http://www.luxmanual.com>

<http://aubethermostatmanual.com>

Golf course search by state

<http://golfingnear.com>

Email search by domain

<http://emailbydomain.com>

Auto manuals search

<http://auto.somanuals.com>

TV manuals search

<http://tv.somanuals.com>