

**KIT FEATURES**

- ▶ Shaft and DIN unit provisions
- ▶ Equalizer provisions

**KIT COMPONENTS**

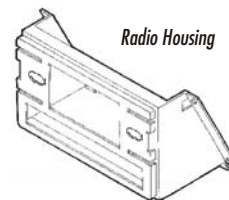

**TOOLS REQUIRED**



Phillips screwdriver



Cutting tool



Adjustable wrench

# 99-7006

## INSTALLATION INSTRUCTIONS

**APPLICATIONS**

<b>CAR</b>	<b>PAGE</b>
<b>EAGLE</b>	
Talon 1995-98.....	1-2
<b>MITSUBISHI</b>	
Eclipse 1995-99.....	1-2



## ALL VEHICLES

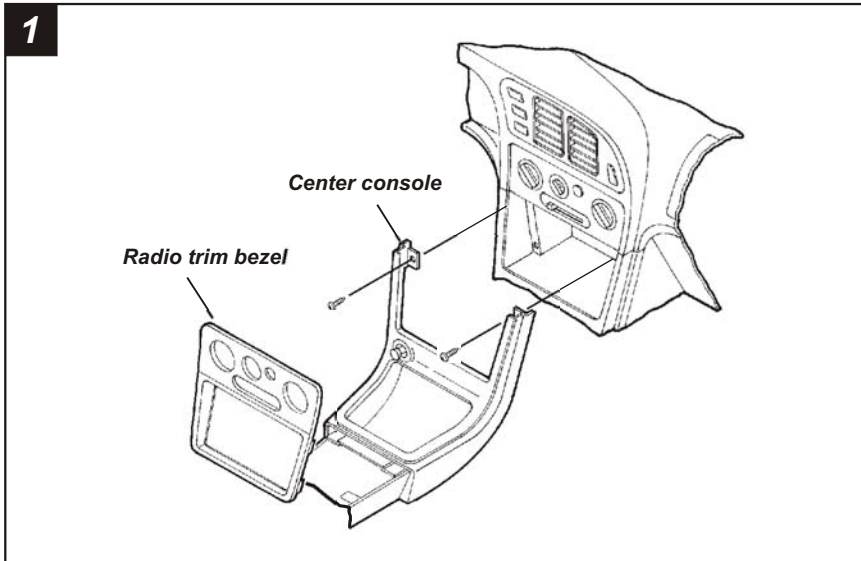

Disconnect the negative battery terminal to prevent an accidental short circuit. Slide the front seats forward. Remove (1) cover cap and (1) Phillips screw from each side of the center console. Unclip the cupholder/ashtray assembly from the center console and remove (2) Phillips screws exposed. Unclip the radio trim bezel and remove (2) Phillips screws exposed. Unscrew the gear shifter knob. Disconnect the cigarette lighter and light wiring. Lift up on the center console and remove. Remove (4) Phillips screws securing the factory head unit and disconnect the wiring.

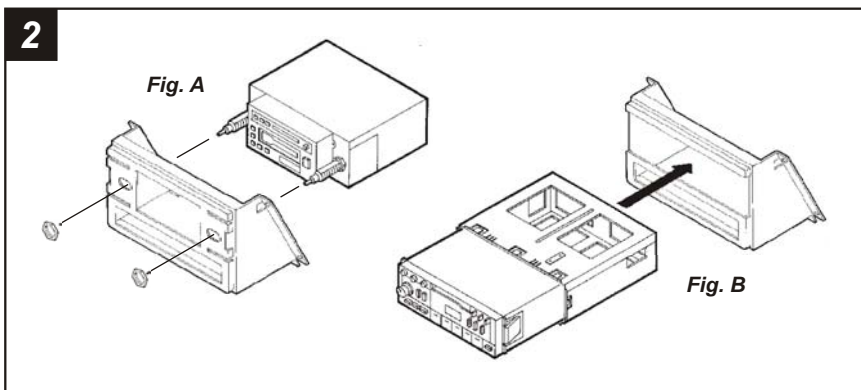

**2-SHAFT HEAD UNITS:** Slide the aftermarket head unit into the kit and secure with shaft nuts. (see Fig. A)

**DIN HEAD UNITS:** Cut and remove the shaft supports from the **Radio Housing**. Slide the DIN cage into the Housing and secure by bending the metal locking tabs down. Slide the aftermarket head unit into the cage until secure. (see Fig. B)

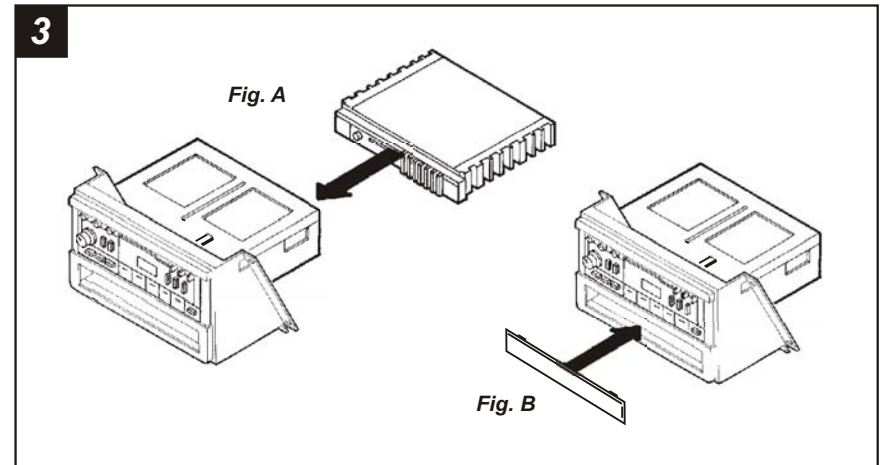

**IF AN EQUALIZER WILL BE INCLUDED:** Slide the aftermarket equalizer into the back of the **Radio Housing**. Using the hardware included with the equalizer, mount the unit to the kit. (see Fig. A)

**IF AN EQUALIZER WILL NOT BE INCLUDED:** Snap the **Equalizer Dummy Plate** into the **Radio Housing**. (see Fig. B)

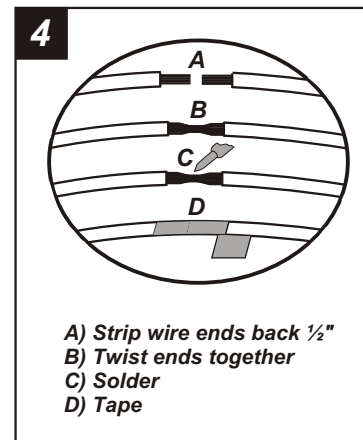

Locate the factory wiring harness in the dash. Metra recommends using the proper mating adaptor and making connections as shown. (Isolate and individually tape off the ends of any unused wires to prevent electrical short circuit).

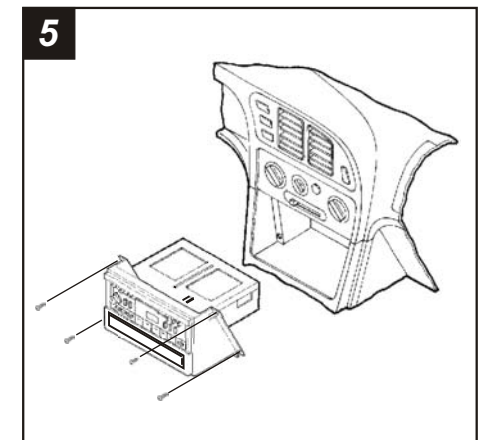

Re-connect the battery terminal and test the unit for proper operation. Mount the head unit/kit assembly to the sub-dash with (4) Phillips screws previously removed in step #1.

## Free Manuals Download Website

<http://myh66.com>

<http://usermanuals.us>

<http://www.somanuals.com>

<http://www.4manuals.cc>

<http://www.manual-lib.com>

<http://www.404manual.com>

<http://www.luxmanual.com>

<http://aubethermostatmanual.com>

Golf course search by state

<http://golfingnear.com>

Email search by domain

<http://emailbydomain.com>

Auto manuals search

<http://auto.somanuals.com>

TV manuals search

<http://tv.somanuals.com>