



INSTALLATION INSTRUCTIONS FOR PART 99-7610

APPLICATIONS

2007-up Nissan Versa 2011 Nissan Juke

99-7610B 99-7610HG

KIT FEATURES

- DIN head unit provisions with pocket
- ISO DIN head unit provision with pocket
- Double DIN mount radio provision
- **B = Matte Black**
- **HG = Gloss Black**



KIT COMPONENTS

A) Radio Housing • B) ISO Brackets • C) Trim Plate • D) DDIN Trim Plate

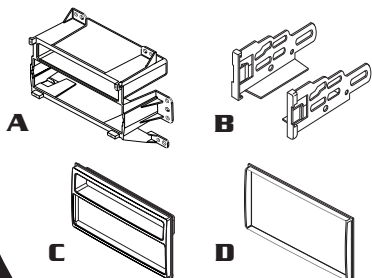

WIRING AND ANTENNA CONNECTIONS

(Sold Separately)

- 70-7552 - 2007-up Nissan Harness
- 40-NI12 - 2007-up Nissan Antenna Adapter

TOOLS REQUIRED:

Panel Removal Tool • Phillips Screwdriver
Socket Wrench



METRA. THE WORLD'S BEST KITS.™



1-800-221-0932



metraonline.com

© COPYRIGHT 2011 METRA ELECTRONICS CORPORATION

Download from www.Somanuals.com. All Manuals Search And Download.



INSTALLATION INSTRUCTIONS FOR PART 99-7610

TABLE OF CONTENTS

Dash Disassembly

- Nissan Versa 2007-up..... 1
- Nissan Juke 2011..... 2

Kit Assembly

- DIN Mount Radio Provision with Pocket 3
- ISO Mount Radio Provision with Pocket 4-5
- Double DIN Mount Radio Provision 6

Caution

Metra recommends disconnecting the negative battery terminal before beginning any installation. All accessories, switches, and especially air bag indicator lights must be plugged in before reconnecting the battery or cycling the ignition.

Note: Refer also to the instructions included with the aftermarket radio.



Metra recommends MECP certified technicians



KNOWLEDGE IS POWER

Enhance your installation and fabrication skills by enrolling in the most recognized and respected mobile electronics school in our industry. Log onto www.installerinstitute.com or call 800-354-6782 for more information and take steps toward a better tomorrow.

99-7610 DASH DISASSEMBLY

2007-UP NISSAN VERSA

1. Unclip and remove the panel above the radio. (Figure A, B)
2. Remove (2) Phillips screws securing the radio trim panel then unclip and remove the entire panel surrounding the radio and a/c controls. (Figure C)
3. Remove (4) Phillips screws securing radio, unplug and remove radio. (Figure D)

Continue to kit assembly.

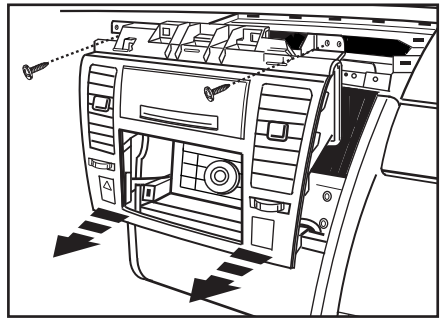

Figure C

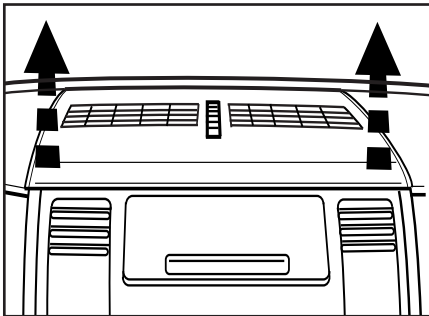

Figure A

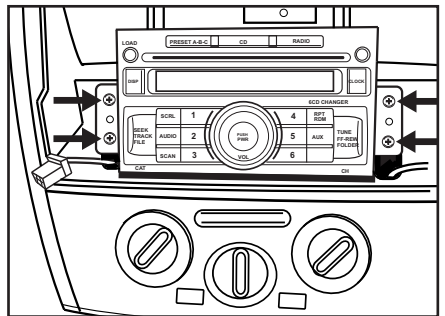

Figure D

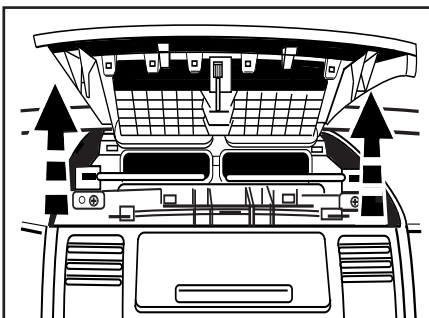

Figure B

99-7610 DASH DISASSEMBLY

2011 NISSAN JUKE

1. Unclip and remove the climate control panel. (Figure A)
2. Remove (2) Phillips screws securing the radio trim panel. (Figure B)
3. Remove (4) Phillips screws securing radio, unplug and remove radio. (Figure C)

Continue to kit assembly.

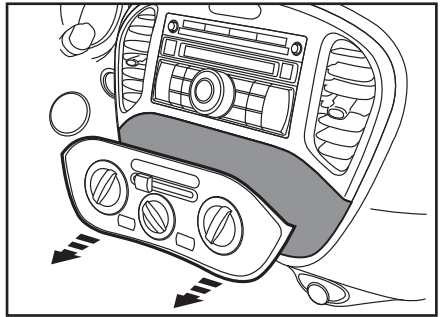

Figure A

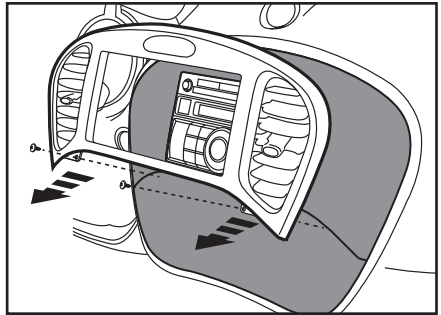

Figure B

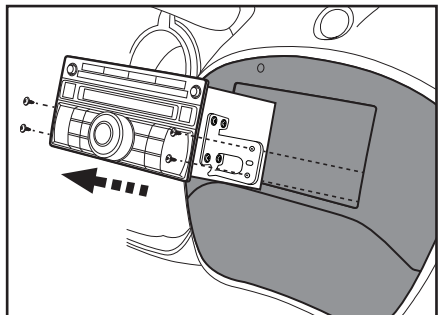

Figure C

DIN HEAD UNIT PROVISION

Note: You will need to remove the aftermarket radio's trim ring if equipped.

1. Cut and remove the appropriate tabs not necessary for your application. (Figure A)
2. Slide the DIN cage into the Radio Housing and secure by bending the metal locking tabs down. (Figure B)
3. Slide the aftermarket head unit into the cage and secure. (Figure C)
4. Locate the factory wiring harness and antenna plug in the dash. Metra recommends using the proper mating adapters from Metra and/or AXCESS.
5. Attach the trim plate supplied with the kit to the front of the radio housing assembly. (Figure C)
6. Reassemble dash in reverse order of disassembly.

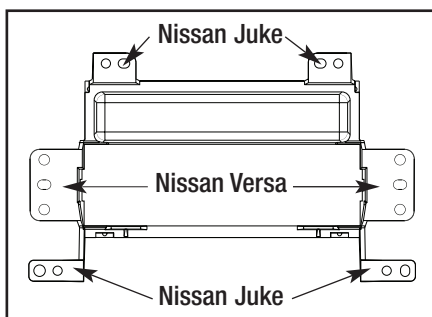

Figure A

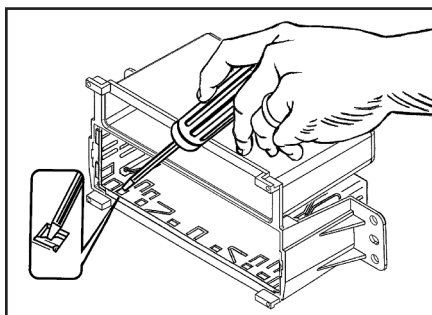

Figure B

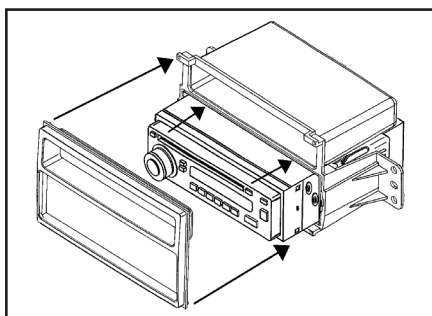

Figure C

ISO MOUNT RADIO PROVISION

Note: The following modification will need to be made to both ISO brackets when using the ISO mount radio provision. Cut or trim the area shown from the ISO bracket. (Figure A)

1. Cut and remove the appropriate tabs not necessary for your application. (Figure B)

Continued on page 5.

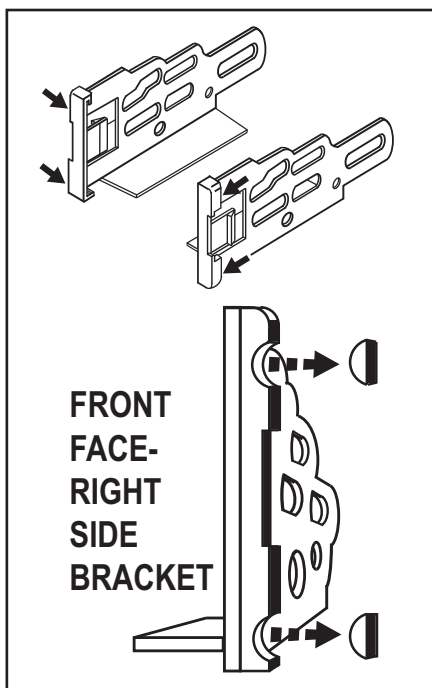

Figure A

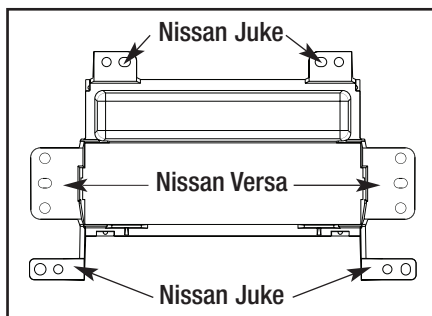

Figure B

99-7610

1. Mount the ISO Brackets to the head unit with the screws supplied with the unit. (Figure C)
2. Slide the head unit into the radio opening until the side clips engage. (Figure D)
3. Locate the factory wiring harness and antenna plug in the dash. Metra recommends using the proper mating adapters from Metra and/or AXCESS.
4. Attach the trim plate supplied with the kit to the front of the radio housing assembly. (Figure D)
5. Reassemble dash in reverse order of disassembly.

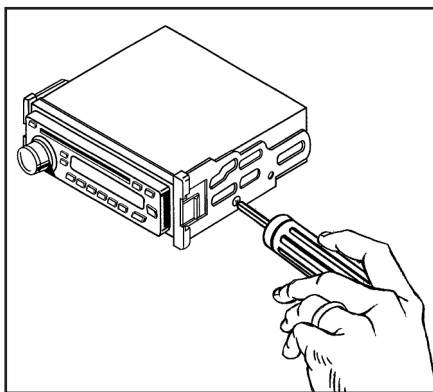

Figure C

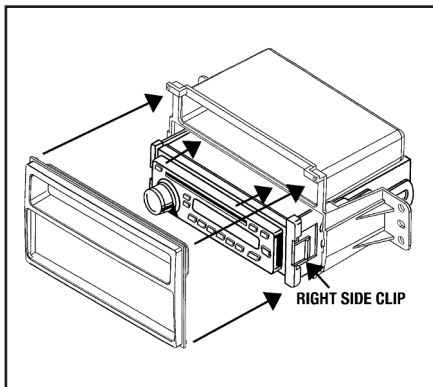

Figure D

DOUBLE DIN MOUNT RADIO PROVISION

1. Mount the factory brackets (removed from factory radio during disassembly) to the sides of the double DIN radio using screws supplied with the double DIN radio. (Figure A)
2. Locate the factory wiring harness and antenna plug in the dash. Metra recommends using the proper mating adapters from Metra and/or AXCESS.
3. Place the DDIN trim plate on the front of the DDIN radio. (Figure B)
4. Reassemble dash in reverse order of disassembly.

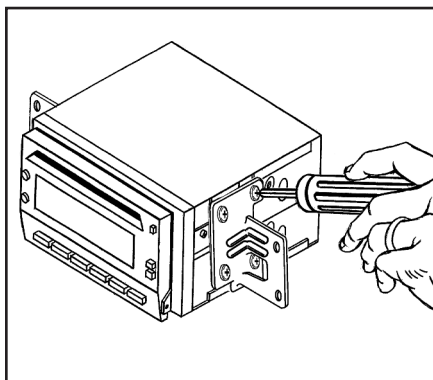

Figure A

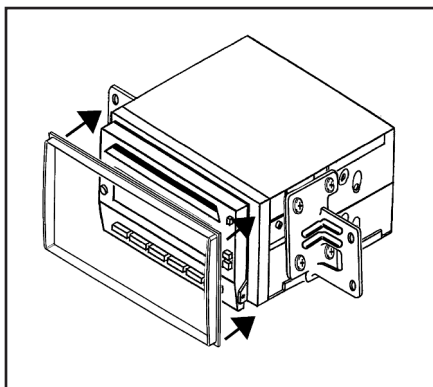

Figure B



99-7610

NOTES

A series of horizontal lines providing a space for handwritten notes, consisting of 24 evenly spaced lines.



INSTALLATION INSTRUCTIONS FOR PART 99-7610

REV. 7/26/11

METRA. THE WORLD'S BEST KITS.™



1-800-221-0932



metraonline.com

© COPYRIGHT 2011 METRA ELECTRONICS CORPORATION

Download from [Www.Somanuals.com](http://www.Somanuals.com). All Manuals Search And Download.

Free Manuals Download Website

<http://myh66.com>

<http://usermanuals.us>

<http://www.somanuals.com>

<http://www.4manuals.cc>

<http://www.manual-lib.com>

<http://www.404manual.com>

<http://www.luxmanual.com>

<http://aubethermostatmanual.com>

Golf course search by state

<http://golfingnear.com>

Email search by domain

<http://emailbydomain.com>

Auto manuals search

<http://auto.somanuals.com>

TV manuals search

<http://tv.somanuals.com>